

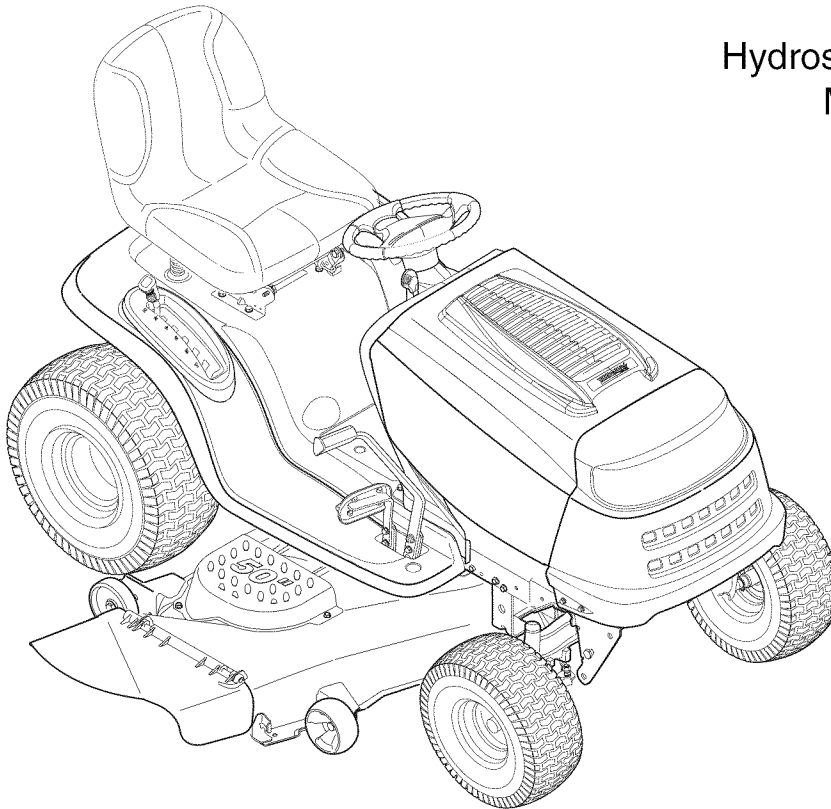

Operator's Manual

Hydrostatic Lawn Tractor
MODEL 615



IMPORTANT: Read safety rules and instructions carefully before operating equipment.

Warning: This unit is equipped with an internal combustion engine and should not be used on or near any unimproved forest-covered, brush-covered or grass-covered land unless the engine's exhaust system is equipped with a spark arrester meeting applicable local or state laws (if any). If a spark arrester is used, it should be maintained in effective working order by the operator. In the State of California the above is required by law (Section 4442 of the California Public Resources Code). Other states may have similar laws. Federal laws apply on federal lands. A spark arrester for the muffler is available through your nearest engine authorized service dealer or contact the service department, P.O. Box 361131 Cleveland, Ohio 44136-9722.

MTD LLC, P.O. BOX 361131 CLEVELAND, OHIO 44136-9722

PRINTED IN U.S.A.

FORM NO. 769-01628
(12/29/2004)

TABLE OF CONTENTS

Content	Page	Content	Page
Customer Support	2	Maintaining Your Lawn Tractor	19
Important Safe Operation Practices	3	Service	20
Tractor Set-Up	8	Off-Season Storage	24
Know Your Lawn Tractor	10	Attachments & Accessories	24
Operating Your Lawn Tractor	13	Troubleshooting	25
Making Adjustments	17	Illustrated Parts List	27

FINDING MODEL NUMBER

This Operator's Manual is an important part of your new lawn tractor. It will help you assemble, prepare and maintain the unit for best performance. Please read and understand what it says.



Before you start assembling your new equipment, please locate the model plate under the seat of the tractor and copy the information in the space provided below. A sample model plate is also given below. This information will be necessary to use the manufacturer's web site and/or help from the Customer Support Department or an authorized service dealer.



Copy the model number here: _____

Copy the serial number here: _____

CUSTOMER SUPPORT

Please do NOT return the unit to the retailer from where it was purchased, without first contacting Customer Support.

If you have difficulty assembling this product or have any questions regarding the controls, operation or maintenance of this unit, you can seek help from the experts. Choose from the options below:

	<p>Visit yardman.com for many useful suggestions. Click on Customer Support button and you will get the four options reproduced here. Click on the appropriate button and help is immediately available.</p> <div style="display: flex; justify-content: space-between; align-items: center; margin-top: 20px;"> <div style="width: 45%; text-align: center;"> <p><i>The answer you are looking for could be just a mouse click away!</i></p> </div> <div style="width: 30%; border: 1px solid black; padding: 5px;"> <div style="border-bottom: 1px solid black; padding: 2px;"> <p>Find Answers Click here to search our knowledge base. Search by product, keyword, or phrase.</p> </div> <div style="border-bottom: 1px solid black; padding: 2px;"> <p>My Stuff Login to check the status of your questions, modify your inquiries, or update your personal profile.</p> </div> <div style="border-bottom: 1px solid black; padding: 2px;"> <p>Service Locator Need local assistance? Click here to find authorized service centers in your area.</p> </div> <div style="padding: 2px;"> <p>Manuals Online Need a manual and/or parts list? Download literature from recent model years.</p> </div> </div> <div style="width: 45%; text-align: center;"> <p><i>The answer you are looking for could be just a mouse click away!</i></p> </div> </div>
	<p>To reach the Customer Support Line, please call 1-800-800-7310.</p>
	<p>The engine manufacturer is responsible for all engine-related issues with regards to performance, power-rating, specifications, warranty and service. Please refer to the engine manufacturer's Owner's/Operator's Manual, at the end of this manual, for more information.</p>

SECTION 1: IMPORTANT SAFE OPERATION PRACTICES



WARNING: This symbol points out important safety instructions which, if not followed, could endanger the personal safety and/or property of yourself and others. Read and follow all instructions in this manual before attempting to operate this machine. Failure to comply with these instructions may result in personal injury. When you see this symbol—heed its warning.



WARNING: The Battery and Engine Exhaust contains chemicals known to the State of California to cause cancer, birth defects or other reproductive harm. The battery and posts contain lead; wash hands after handling.



DANGER: This machine was built to be operated according to the rules for safe operation in this manual. As with any type of power equipment, carelessness or error on the part of the operator can result in serious injury. This machine is capable of amputating hands and feet and throwing objects. Failure to observe the following safety instructions could result in serious injury or death.

GENERAL OPERATION

1. Read, understand, and follow all instructions on the machine and in the manual(s) before attempting to assemble and operate. Keep this manual in a safe place for future and regular reference and for ordering replacement parts.
2. Be familiar with all controls and their proper operation. Know how to stop the machine and disengage them quickly.
3. Never allow children under 14 years old to operate this machine. Children 14 years old and over should read and understand the operation instructions and safety rules in this manual and should be trained and supervised by a parent.
4. Never allow adults to operate this machine without proper instruction.
5. To help avoid blade contact or a thrown object injury, keep bystanders, helpers, children and pets at least 75 feet from the machine while it is in operation. Stop machine if anyone enters the area.
6. Thoroughly inspect the area where the equipment is to be used. Remove all stones, sticks, wire, bones, toys, and other foreign objects which could be picked up and thrown by the blade(s). Thrown objects can cause serious personal injury.
7. Plan your mowing pattern to avoid discharge of material toward roads, sidewalks, bystanders and the like. Also, avoid discharging material against a wall or obstruction which may cause discharged material to ricochet back toward the operator.
8. Always wear safety glasses or safety goggles during operation and while performing an adjustment or repair to protect your eyes. Thrown objects which ricochet can cause serious injury to the eyes.
9. Wear sturdy, rough-soled work shoes and close-fitting slacks and shirts. Loose fitting clothes and jewelry can be caught in movable parts. Never operate this machine in bare feet or sandals.
10. Be aware of the mower and attachment discharge direction and do not point it at anyone. Do not operate the mower without the discharge cover or entire grass catcher in its proper place.
11. Do not put hands or feet near rotating parts or under the cutting deck. Contact with the blade(s) can amputate hands and feet.
12. A missing or damaged discharge cover can cause blade contact or thrown object injuries.
13. Stop the blade(s) when crossing gravel drives, walks, or roads and while not cutting grass.
14. Watch for traffic when operating near or crossing roadways. This machine is not intended for use on any public roadway.
15. Do not operate the machine while under the influence of alcohol or drugs.
16. Mow only in daylight or good artificial light.
17. Never carry passengers.
18. Disengage blade(s) before shifting into reverse. Back up slowly. Always look down and behind before and while backing to avoid a back-over accident.
19. Slow down before turning. Operate the machine smoothly. Avoid erratic operation and excessive speed.
20. Disengage blade(s), set parking brake, stop engine and wait until the blade(s) come to a complete stop before removing grass catcher, emptying grass, unclogging chute, removing any grass or debris, or making any adjustments.
21. Never leave a running machine unattended. Always turn off blade(s), place transmission in neutral, set parking brake, stop engine and remove key before dismounting.
22. Use extra care when loading or unloading the machine into a trailer or truck. This unit should not be driven up or down ramp(s), because the unit could tip over, causing serious personal injury. The unit must be pushed manually on ramp(s) to load or unload properly.

23. Muffler and engine become hot and can cause a burn. Do not touch.
24. Check overhead clearances carefully before driving under low hanging tree branches, wires, door openings etc., where the operator may be struck or pulled from the unit, which could result in serious injury.
25. Disengage all attachment clutches, depress the brake pedal completely and shift into neutral before attempting to start engine.
26. Your machine is designed to cut normal residential grass of a height no more than 10". Do not attempt to mow through unusually tall, dry grass (e.g., pasture) or piles of dry leaves. Dry grass or leaves may contact the engine exhaust and/or build up on the mower deck presenting a potential fire hazard.
27. Use only accessories and attachments approved for this machine by the machine manufacturer. Read, understand and follow all instructions provided with the approved accessory or attachment.
28. Data indicates that operators, age 60 years and above, are involved in a large percentage of riding mower-related injuries. These operators should evaluate their ability to operate the riding mower safely enough to protect themselves and others from serious injury.
29. If situations occur which are not covered in this manual, use care and good judgment. Contact an authorized MTD service dealer for assistance.

SLOPE OPERATION

Slopes are a major factor related to loss of control and tip-over accidents which can result in severe injury or death. All slopes require extra caution. If you cannot back up the slope or if you feel uneasy on it, do not mow it.

For your safety, use the slope gauge included as part of this manual to measure slopes before operating this unit on a sloped or hilly area. If the slope is greater than 15 degrees as shown on the slope gauge, do not operate this unit on that area or serious injury could result.

DO:

1. Mow up and down slopes, not across. Exercise extreme caution when changing direction on slopes.
2. Watch for holes, ruts, bumps, rocks, or other hidden objects. Uneven terrain could overturn the machine. Tall grass can hide obstacles.

3. Use slow speed. Choose a low enough speed setting so that you will not have to stop or shift while on the slope. Tires may lose traction on slopes even though the brakes are functioning properly. Always keep machine in gear when going down slopes to take advantage of engine braking action.
4. Follow the manufacturer's recommendations for wheel weights or counterweights to improve stability.
5. Use extra care with grass catchers or other attachments. These can change the stability of the machine.
6. Keep all movement on the slopes slow and gradual. Do not make sudden changes in speed or direction. Rapid engagement or braking could cause the front of the machine to lift and rapidly flip over backwards which could cause serious injury.
7. Avoid starting or stopping on a slope. If tires lose traction, disengage the blade(s) and proceed slowly straight down the slope.

DO NOT:

1. Do not turn on slopes unless necessary; then, turn slowly and gradually downhill, if possible.
2. Do not mow near drop-offs, ditches or embankments. The mower could suddenly turn over if a wheel is over the edge of a cliff, ditch, or if an edge caves in.
3. Do not try to stabilize the machine by putting your foot on the ground.
4. Do not use a grass catcher on steep slopes.
5. Do not mow on wet grass. Reduced traction could cause sliding.
6. Do not shift to neutral and coast downhill. Over-speeding may cause the operator to lose control of the machine resulting in serious injury or death.
7. Do not tow heavy pull behind attachments (e.g. loaded dump cart, lawn roller, etc.) on slopes greater than 5 degrees. When going down hill, the extra weight tends to push the tractor and may cause you to lose control. (e.g. tractor may speed up, braking and steering ability are reduced, attachment may jack-knife and cause tractor to overturn).

CHILDREN

1. Tragic accidents can occur if the operator is not alert to the presence of children. Children are often attracted to the machine and the mowing activity. They do not understand the dangers. Never assume that children will remain where you last saw them.
 - a. Keep children out of the mowing area and in watchful care of a responsible adult other than the operator.
 - b. Be alert and turn machine off if a child enters the area.

- c. Before and while backing, look behind and down for small children.
 - d. Never carry children, even with the blade(s) shut off. They may fall off and be seriously injured or interfere with safe machine operation.
 - e. Use extreme care when approaching blind corners, doorways, shrubs, trees or other objects that may block your vision of a child who may run into the machine.
 - f. **To avoid back-over accidents, always disengage the cutting blade(s) before shifting into reverse. The “Reverse Caution Mode” should not be used when children or others are around.**
 - g. Keep children away from hot or running engines. They can suffer burns from a hot muffler.
 - h. Remove key when machine is unattended to prevent unauthorized operation.
9. Never allow children under 14 years old to operate the machine. Children 14 years old and over should read and understand the operation instructions and safety rules in this manual and should be trained and supervised by a parent.

TOWING

1. Tow only with a machine that has a hitch designed for towing. Do not attach towed equipment except at the hitch point.
2. Follow the manufacturers recommendation for weight limits for towed equipment and towing on slopes.
3. Never allow children or others in or on towed equipment.
4. On slopes, the weight of the towed equipment may cause loss of traction and loss of control.
5. Travel slowly and allow extra distance to stop.
6. Do not shift to neutral and coast downhill.

SERVICE

SAFE HANDLING OF GASOLINE:

1. **To avoid personal injury or property damage** use extreme care in handling gasoline. **Gasoline is** extremely flammable and the vapors are explosive. Serious personal injury can occur when gasoline is spilled on yourself or your clothes which can ignite. Wash your skin and change clothes immediately.
 - a. Use only an approved gasoline container.
 - b. Never fill containers inside a vehicle or on a truck or trailer bed with a plastic liner. Always place containers on the ground away from your vehicle before filling.

- c. When practical, remove gas-powered equipment from the truck or trailer and refuel it on the ground. If this is not possible, then refuel such equipment on a trailer with a portable container, rather than from a gasoline dispenser nozzle.
- d. Keep the nozzle in contact with the rim of the fuel tank or container opening at all times until fueling is complete. Do not use a nozzle lock-open device.
- e. Extinguish all cigarettes, cigars, pipes and other sources of ignition.
- f. Never fuel machine indoors.
- g. Never remove gas cap or add fuel while the engine is hot or running. Allow engine to cool at least two minutes before refueling.
- h. Never over fill fuel tank. Fill tank to no more than ½ inch below bottom of filler neck to allow space for fuel expansion.
- i. Replace gasoline cap and tighten securely.
- j. If gasoline is spilled, wipe it off the engine and equipment. Move unit to another area. Wait 5 minutes before starting the engine.
- k. To reduce fire hazards, keep machine free of grass, leaves, or other debris build-up. Clean up oil or fuel spillage and remove any fuel soaked debris.
- l. Never store the machine or fuel container inside where there is an open flame, spark or pilot light as on a water heater, space heater, furnace, clothes dryer or other gas appliances.
- m. Allow a machine to cool at least 5 minutes before storing.

GENERAL SERVICE:

1. Never run an engine indoors or in a poorly ventilated area. Engine exhaust contains carbon monoxide, an odorless, and deadly gas.
2. Before cleaning, repairing, or inspecting, make certain the blade(s) and all moving parts have stopped. Disconnect the spark plug wire and ground against the engine to prevent unintended starting.
3. Periodically check to make sure the blades come to complete stop within approximately (5) five seconds after operating the blade disengagement control. If the blades do not stop within the this time frame, your unit should be serviced professionally by an authorized *MTD* Service dealer.
4. Check brake operation frequently as it is subjected to wear during normal operation. Adjust and service as required.
5. Check the blade(s) and engine mounting bolts at frequent intervals for proper tightness. Also, visually inspect blade(s) for damage (e.g., excessive wear, bent, cracked).

6. Replace the blade(s) with the original equipment manufacturer's (O.E.M.) blade(s) only, listed in this manual. "Use of parts which do not meet the original equipment specifications may lead to improper performance and compromise safety!"
7. Mower blades are sharp. Wrap the blade or wear gloves, and use extra caution when servicing them.
8. Keep all nuts, bolts, and screws tight to be sure the equipment is in safe working condition.
9. Never tamper with the safety interlock system or other safety devices. Check their proper operation regularly.
10. After striking a foreign object, stop the engine, disconnect the spark plug wire(s) and ground against the engine. Thoroughly inspect the machine for any damage. Repair the damage before starting and operating.
11. Never attempt to make adjustments or repairs to the machine while the engine is running.
12. Grass catcher components and the discharge cover are subject to wear and damage which could expose moving parts or allow objects to be thrown. For safety protection, frequently check components and replace immediately with original equipment manufacturer's (O.E.M.) parts only, listed in this manual. "Use of parts which do not meet the original equipment specifications may lead to improper performance and compromise safety!"
13. Do not change the engine governor settings or over-speed the engine. The governor controls the maximum safe operating speed of the engine.
14. Maintain or replace safety and instruction labels, as necessary.
15. Observe proper disposal laws and regulations for gas, oil, etc. to protect the environment.



WARNING: YOUR RESPONSIBILITY Restrict the use of this power machine to persons who read, understand and follow the warnings and instructions in this manual and on the machine.



DANGER

ROTATING BLADES CAUSE SERIOUS INJURY OR DEATH

- DO NOT MOW WHEN CHILDREN OR OTHERS ARE AROUND
- NEVER CARRY CHILDREN EVEN WITH BLADE(S) OFF.
- LOOK DOWN AND BEHIND BEFORE AND WHILE BACKING.
- MOWING IN REVERSE IS NOT RECOMMENDED.

WARNING

TO AVOID SERIOUS INJURY OR DEATH

- GO UP AND DOWN SLOPES, NOT ACROSS.
- AVOID SUDDEN TURNS.
- DO NOT OPERATE THE UNIT WHERE IT COULD SLIP OR TIP.
- IF MACHINE STOPS GOING UPHILL, STOP BLADE(S) AND BACK DOWNHILL SLOWLY.
- KEEP SAFETY DEVICES (GUARDS, SHIELDS, AND SWITCHES, ETC.) IN PLACE AND WORKING.
- REMOVE OBJECTS THAT COULD BE THROWN BY THE BLADE(S).
- KNOW LOCATION AND FUNCTION OF ALL CONTROLS.
- BE SURE BLADE(S) AND ENGINE ARE STOPPED BEFORE PLACING HANDS OR FEET NEAR BLADE(S).
- BEFORE LEAVING OPERATOR'S POSITION, DISENGAGE BLADE(S), ENGAGE PARKING BRAKE, SHUT OFF AND REMOVE KEY.

READ OPERATOR'S MANUAL

SECTION 2: SLOPE GAUGE

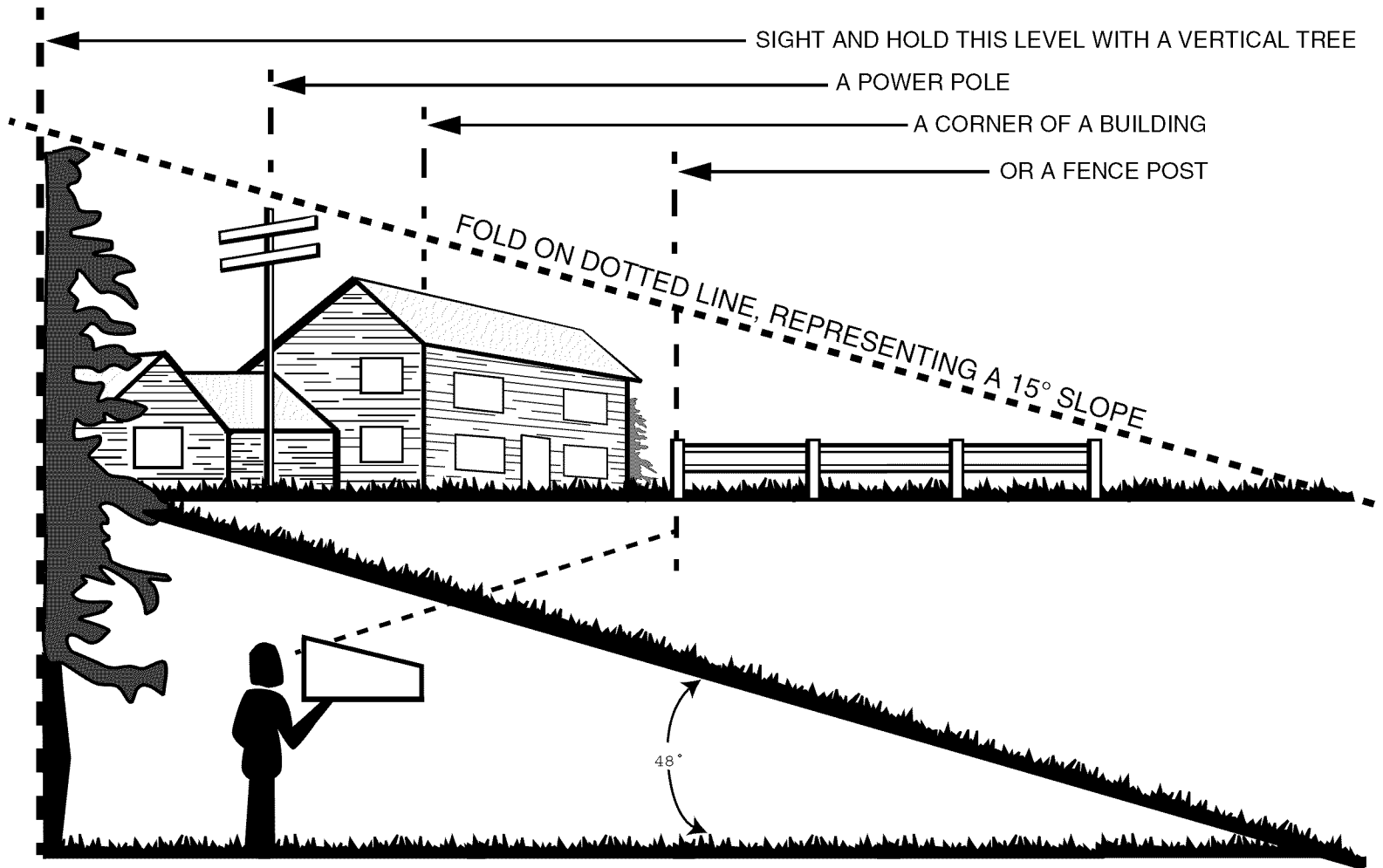

WARNING

Do not mow on inclines with a slope in excess of 15 degrees (a rise of approximately 2-1/2 feet every 10 feet). A riding mower could overturn and cause serious injury. If operating a walk-behind mower on such a slope, it is extremely difficult to maintain your footing and you could slip, resulting in serious injury. Operate RIDING mowers up and down slopes, never across the face of slopes.

SECTION 3: TRACTOR SET-UP

Attaching the Battery Cables

NOTE: The positive battery terminal is marked Pos. (+). The negative battery terminal is marked Neg. (-).

- The positive cable (heavy red wire) is secured to the positive battery terminal (+) with a hex bolt and hex nut at the factory. Make certain that the rubber boot covers the terminal to help protect it from corrosion.
- Remove the hex bolt and wing nut from the negative cable.
- Remove the black plastic cover, if present, from the negative battery terminal and attach the negative cable (heavy black wire) to the negative battery terminal (-) with the bolt and wing nut.
- Make certain the hold-down strap is in position over the battery, securing it in place. See Figure 1.

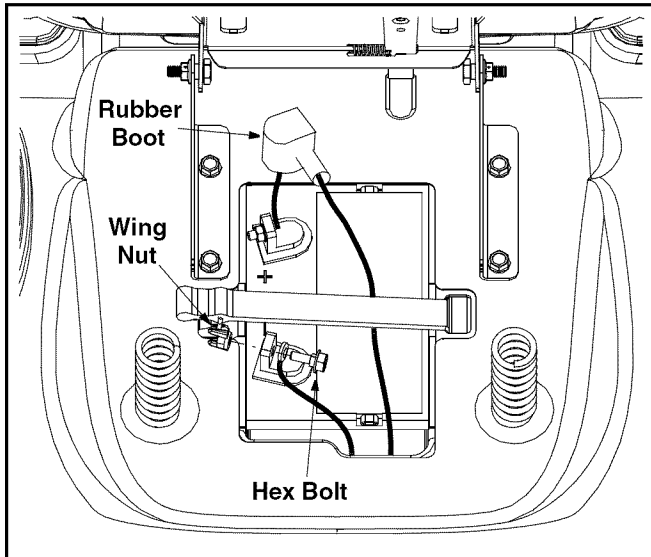

Figure 1

NOTE: If the battery is put into service after the date shown on top of battery, charge the battery as instructed on page 22 of this manual prior to operating the tractor.

Attaching The Steering Wheel

- If the steering wheel for your tractor did not come attached, the hardware for attaching it has been packed within the steering wheel, beneath the steering wheel cap. Carefully pry off the steering wheel cap and remove the hardware.

NOTE: There are two different styles of steering wheel cap. See Figure 2. **Styles vary by model.**

- With the wheels of the tractor pointing straight forward, place the steering wheel over the steering shaft.
- Place the washer (with the cupped side down) over the steering shaft and secure with the hex bolt. See Figure 2.
- Place the steering wheel cap over the center of the steering wheel and push downward until it “clicks” into place.

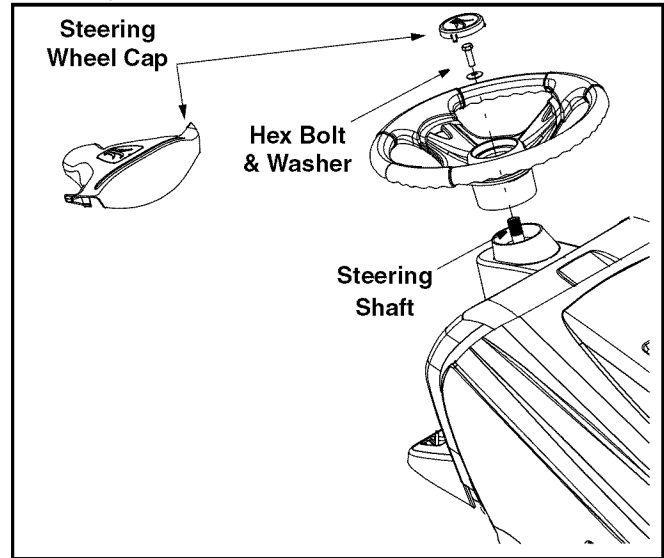

Figure 2

Attaching The Seat

If the seat for your tractor did not come attached, refer to WARNING: and follow the applicable instructions below to attach it.

NOTE: For shipping reasons, seats are either fastened to the tractor seat's pivot bracket with a plastic tie, or mounted backward to the pivot bracket. If your seat was shipped mounted backwards on the seat pivot bracket, pull out the tab found on the seat stop and hold it open while sliding the seat off the seat pivot bracket. See Figure 3.

1. Line up the plastic seat spacers with the slots in seat pivot bracket.
2. Slide seat in until front seat spacer engages the seat stop. See Figure 3.



WARNING: Before operating this machine, make sure the seat is engaged in the seat stop, stand behind the machine and pull back on seat until fully engaged into stop.

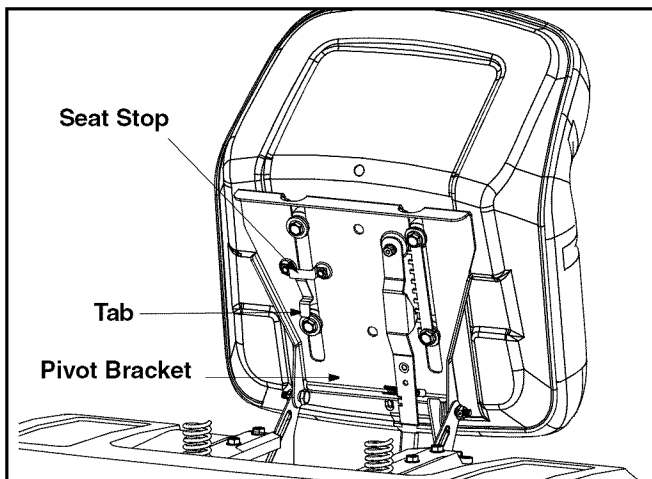

Figure 3

Gas and Oil Fill-up

The gasoline tank is located under the hood and has a capacity of either two or three gallons. Do not overfill.



WARNING: Use extreme care when handling gasoline. Gasoline is extremely flammable and the vapors are explosive. Never fuel machine indoors or while engine is hot or running. Extinguish cigarettes, cigars, pipes, and other sources of ignition.

Service the engine with gasoline and oil as instructed in the separate *Briggs & Stratton* Operator/Owner Manual (or *Kohler* engine's Owner's Manual) packed with your tractor. Read instructions carefully.

IMPORTANT: Your tractor is shipped with motor oil in the engine. However, you **MUST** check the oil level before operating. Be careful not to overfill.

Tire Pressure



WARNING: Maximum tire pressure under any circumstances is 30 psi. Equal tire pressure should be maintained at all times.

The tires on your unit may be over-inflated for shipping purposes. Reduce the tire pressure before operating the tractor. Recommended operating tire pressure is approximately 10 p.s.i for the rear tires & 14 p.s.i. for the front tires. Check sidewall of tire for maximum p.s.i.

Shipping Brace Removal



WARNING: Make sure the riding mower's engine is off, set the parking brake and remove the ignition key before removing the shipping brace.

- Locate the shipping brace and warning tag found on the right side of the cutting deck. See Figure 4.

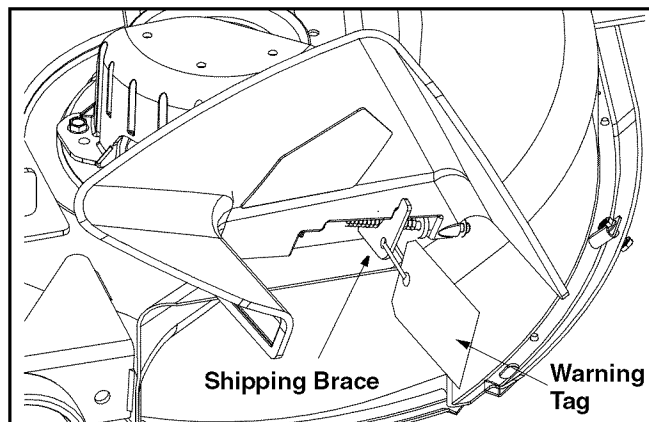

Figure 4

- While holding the discharge chute with your left hand, remove the shipping brace with your right hand by grasping it between your thumb and index finger and rotating it clockwise.



WARNING: The shipping brace, used for packaging purposes only, must be removed and discarded before operating your riding mower.



WARNING: The mowing deck is capable of throwing objects. Failure to operate riding mower without the discharge cover in proper operating position could result in serious personal injury and/or property damage.

Identifying the Mulch Plug

The mulch plug can be found within the cutting deck's discharge opening.

NOTE: Refer to **Mulching** on page 16 for more detailed information and how to reinstall mulch plug.

If you'd prefer to operate the cutting deck without mulching, carefully remove the mulch plug and lower the discharge chute slowly. This will allow the clippings to discharge out of the discharge opening during operation. See Figure 5 .

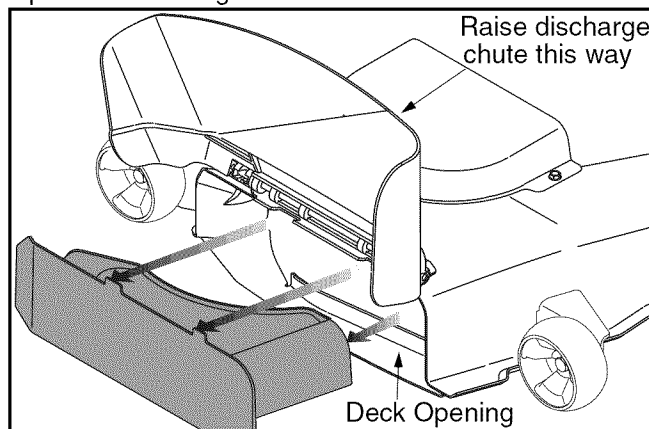
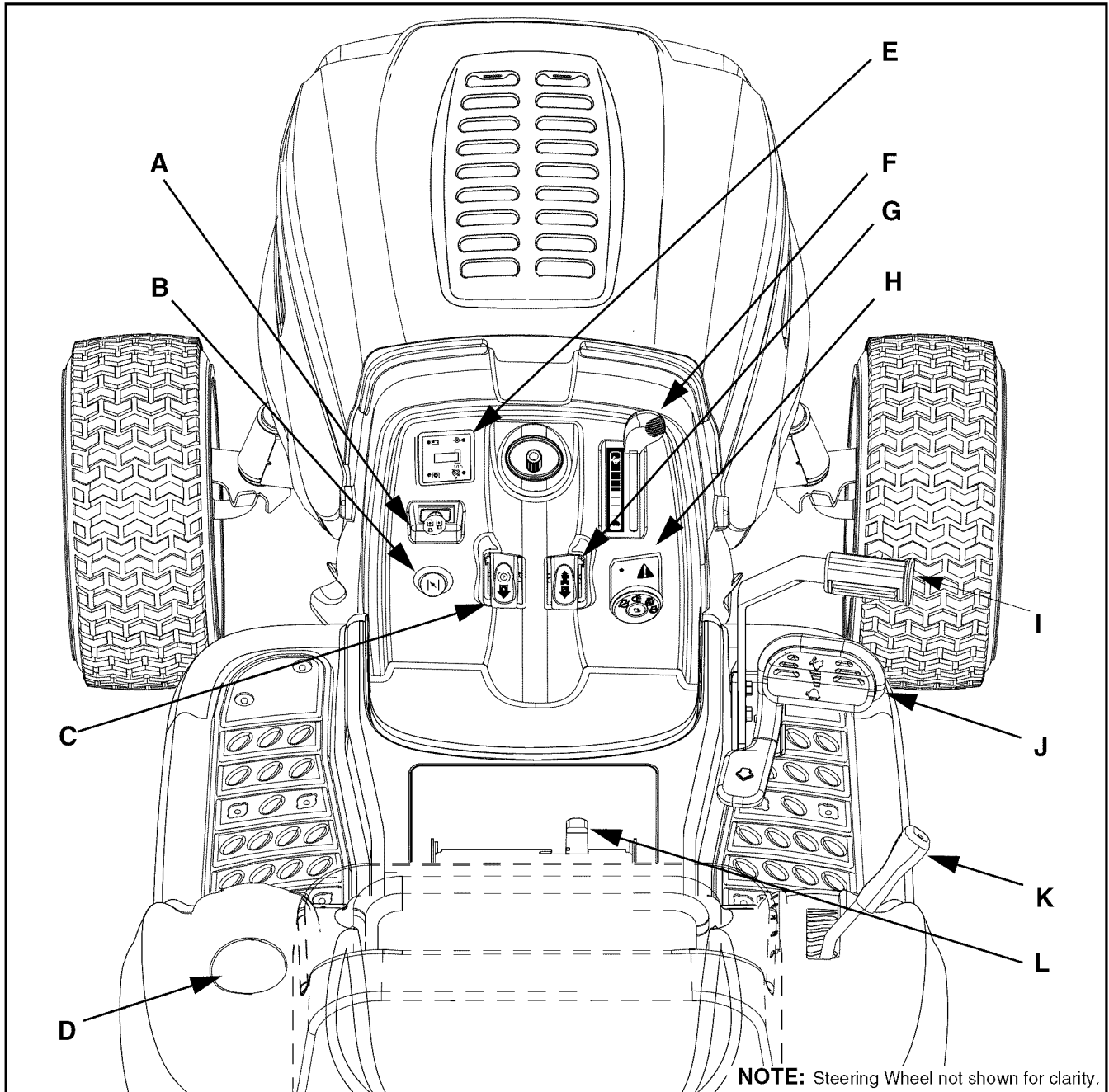

Figure 5

SECTION 4: KNOW YOUR LAWN TRACTOR



- A PTO (Power Take-off) Knob
- B Choke Control
- C Parking Brake Button
- D Cup Holder
- E Hour Meter
- F Throttle Control Lever

- G Cruise Control Button
- H Ignition Switch Module
- I Brake Pedal
- J Drive Pedal
- K Deck Lift Lever
- L Seat Adjustment Lever

NOTE: Any reference in this manual to the RIGHT or LEFT side of the tractor is observed from operator's position.

Throttle Control Lever

The throttle control lever is located on the right side of the tractor's dash panel. This lever controls the speed of the engine. When set in a given position, the throttle will maintain a uniform engine speed.

IMPORTANT: When operating the tractor with the cutting deck engaged, be certain that the throttle lever is **always** in the FAST (rabbit) position.

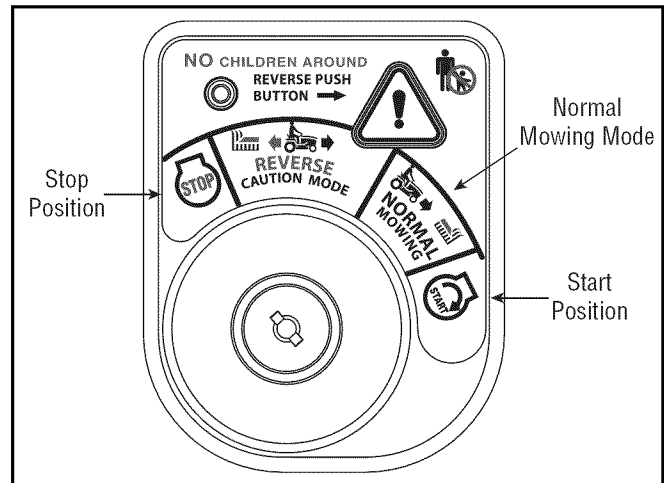
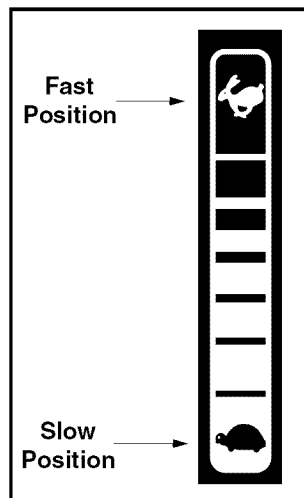
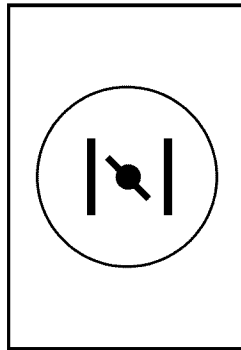

Figure 6

Prior to operating the tractor, refer to both **Safety Interlock Switches** on page 13 and **Starting The Engine** on page 14 of this manual for detailed instructions regarding the Ignition Switch Module and operating the tractor in **REVERSE CAUTION MODE**.

Choke Control

The choke control can be found on the left side of the dash panel and is activated by pulling the knob outward. Activating the choke control closes the choke plate on the carburetor and aids in starting the engine. Refer to **Starting The Engine** on page 14 of this manual for detailed starting instructions.



Brake Pedal

The brake pedal is located on the right front side of the tractor above the drive pedal along the running board. The brake pedal can be used for sudden stops or setting the parking brake.

NOTE: The brake pedal must be fully depressed to activate the safety interlock switch when starting the tractor.

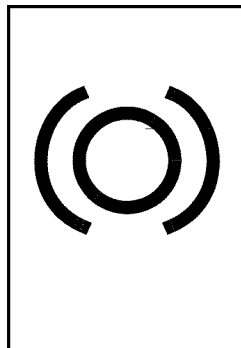

Drive Pedal

The drive pedal is located below the brake pedal on the right front side of the tractor along the running board. Depress the upper portion of the drive pedal forward to cause the tractor to travel forward. Depress the lower portion of the drive pedal with the ball of your right foot (NOT your heel) to cause the tractor to travel in reverse. Ground speed is also controlled with the drive pedal. The further forward or rearward that the pedal is pivoted, the faster the tractor will travel. The pedal will return to its original position when it's not depressed.

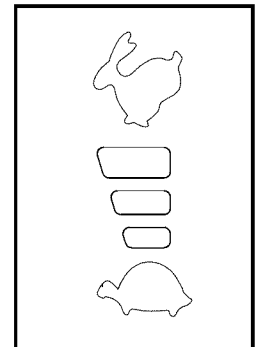

IMPORTANT: Always set the parking brake when leaving the tractor unattended.

Ignition Switch Module



WARNING: Never leave a running machine unattended. Always disengage PTO, set parking brake, stop engine and remove key to prevent unintended starting.

To start the engine, insert the key into the ignition switch and turn clockwise to the **START** position. Release the key into the **NORMAL MOWING MODE** position once the engine has fired.

To stop the engine, turn the ignition key counterclockwise to the STOP position. See Figure 6.

Systems Indicator Monitor

Your tractor is equipped with an hour meter as part of the available systems indicator monitor. Locate the monitor on the left side of your dash panel and compare it to both shown in Figure 7.

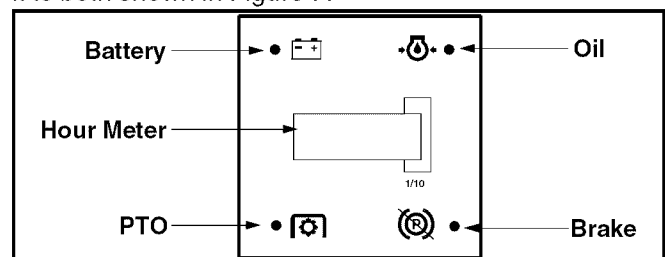

Figure 7

If the Brake light or PTO light illuminates when attempting to start the unit, proceed as follows:

BRAKE — Depress the brake pedal.

PTO — Move PTO knob into the disengaged (OFF) position.

It is normal for the Oil light and the Battery light, if so equipped, to illuminate while the engine is **cranking**, but if either illuminates **while the engine is running**, proceed as follows:

OIL— Stop the tractor immediately and check the crankcase oil level as instructed in the Briggs & Stratton Operator/Owner Manual (or Kohler engine's Owner's Manual) included with your tractor.

BATTERY— The battery is in need of a charge, or the engine's charging system is not generating sufficient amperage. Refer to the **MAINTENANCE** section of this manual for the proper battery charging procedure or have the charging system checked by a Briggs & Stratton or Kohler engine's dealer.

The **hour meter** operates whenever the engine is running and records the actual hours of tractor operation.

Electric PTO (Power Take-off) Knob

To engage the power to the cutting deck or other (separately available) attachments on models equipped with an electric PTO, pull outward on the PTO knob. Push the PTO knob inward to disengage the power to the cutting deck.

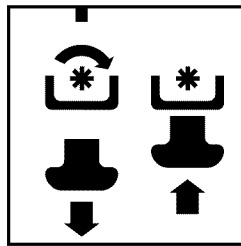

NOTE: The PTO knob **must** be in the disengaged (OFF) position when starting the engine, when traveling in reverse and if the operator leaves the seat.

Seat Adjustment Lever

To adjust the seat forward or backward, slide the seat adjustment lever to the left and reposition the seat to the desired position. Once a comfortable position is found, release the seat adjustment lever to lock the seat in place. Refer to **Seat Adjustment** on page 18 of this manual for more detailed instructions.

Deck Lift Lever

Found on your tractor's right fender, the deck lift lever is used to change the height of the cutting deck. To use, move the lever to the left, then place in the notch best suited for your application.

Cup Holder

The tractor's cup holder is located on the fender to the left of the seat, just to the rear of the shift lever.

Parking Brake Button

To set the parking brake, fully depress the brake pedal and push the parking brake button in. Hold the button in while taking your foot off the brake pedal. Both the parking button and the brake pedal will then stay depressed. To release the parking brake, depress the brake pedal slightly. The parking brake button will then return to its original position.

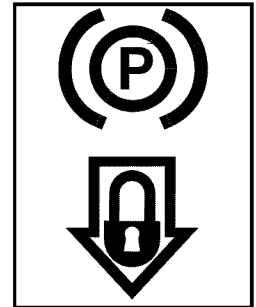

NOTE: The parking brake must be set if the operator leaves the seat with the engine running or the engine will automatically shut off.

IMPORTANT: Always set the parking brake when leaving the tractor unattended.

Cruise Control Button

The cruise control button, on models so equipped, is located on the tractor dash panel to the left of the ignition switch. Push the cruise control button while traveling forward at a desired speed. While holding the button in, release pressure from the drive pedal. This will engage the cruise control and allow the tractor to remain at that speed without applying pressure to the drive pedal. Depress the brake pedal or the drive pedal to deactivate cruise control. Refer to **Setting the Cruise Control** on page 15 this manual for detailed instructions regarding the cruise control feature.

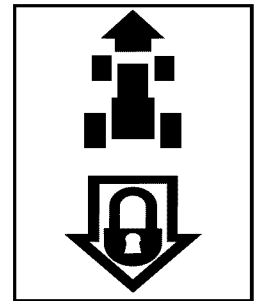

NOTE: Cruise control can NOT be engaged at the tractor's fastest ground speed. If the operator should attempt to do so, the tractor will automatically decelerate to the fastest optimal mowing ground speed.

SECTION 5: OPERATING YOUR LAWN TRACTOR



WARNING: Read, understand, and follow all instructions and warnings on the machine and in this manual before operating.

Safety Interlock Switches

This tractor is equipped with a safety interlock system for the protection of the operator. If the interlock system should ever malfunction, do not operate the tractor. Contact an authorized *MTD* service dealer.

- The safety interlock system prevents the engine from cranking or starting unless the parking brake is engaged, and the PTO (Blade Engage) knob is in the disengaged (OFF) position.
- The engine will automatically shut off if the operator leaves the seat before engaging the parking brake.
- The engine will automatically shut off if the operator engages the PTO with the parking brake ON.
- The electric PTO (Blade Engage) clutch will automatically shut off if the operator leaves the tractor's seat with the PTO (Blade Engage) knob in the engaged (ON) position, regardless of whether the parking brake is engaged.
- With the ignition key in the **NORMAL MOWING** position, the electric PTO (Blade Engage) clutch will automatically shut off if the PTO (Blade Engage) knob is moved into the engaged (ON) position with the shift lever in Reverse.



WARNING: Do not operate the tractor if the interlock system is malfunctioning. This system was designed for your safety and protection.

Reverse Caution Mode



WARNING: Use extreme caution while operating the tractor in the **REVERSE CAUTION MODE**. Always look down and behind before and while backing. Do not operate the tractor when children or others are around. Stop the tractor immediately if someone enters the area.

The **REVERSE CAUTION MODE** position of the key switch module allows the tractor to be operated in reverse with the blades (PTO) engaged.

IMPORTANT: *Mowing in reverse is not recommended.*

To use the **REVERSE CAUTION MODE**:

IMPORTANT: *The operator MUST be seated in the tractor seat.*

1. Start the engine as previously instructed in this Operator's Manual.

2. Turn the key from the **NORMAL MOWING** (Green) position to the **REVERSE CAUTION MODE** (Yellow) position of the key switch module. See Figure 8.
3. Depress the **REVERSE PUSH BUTTON** (Orange, Triangular Button) at the top, right corner of the key switch module. The red indicator light at the top, left corner of the key switch module will be **ON** while activated. See Figure 8.
4. Once activated (indicator light **ON**), the tractor can be driven in reverse with the cutting blades (PTO) engaged.
5. Always look down and behind before and while backing to make sure no children are around.
6. After resuming forward motion, return the key to the **NORMAL MOWING** position.

IMPORTANT: The **REVERSE CAUTION MODE** will remain activated until:

- a. The key is placed in either the **NORMAL MOWING** position or **STOP** position.
- b. The operator leaves the seat.

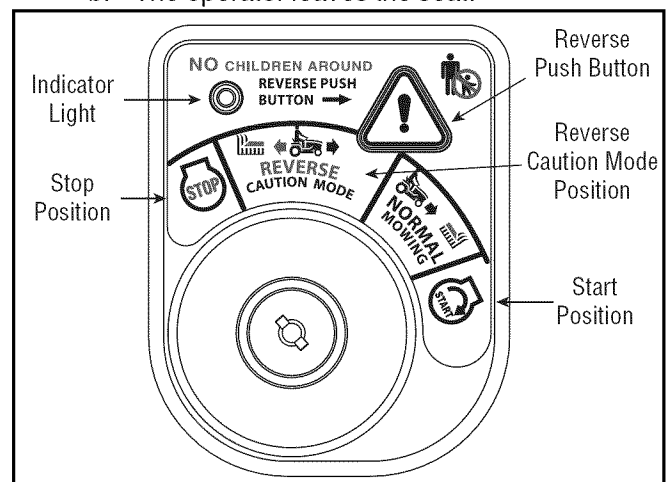

Figure 8

Setting the Cutting Height

Select the height position of the cutting deck by placing the deck lift lever in any of the six different cutting height notches on the right side of the fender. Then adjust the deck wheels so that they are between ¼-inch and ½-inch above the ground when the tractor is on a smooth, flat surface such as a driveway.



WARNING: Keep hands and feet away from the discharge opening of the cutting deck.

NOTE: *The deck wheels are an anti-scalp feature of the deck and are not designed to support the weight of the cutting deck.*



WARNING

AVOID SERIOUS INJURY OR DEATH

- GO UP AND DOWN SLOPES, NOT ACROSS.
- AVOID SUDDEN TURNS.
- DO NOT OPERATE THE UNIT WHERE IT COULD SLIP OR TIP.
- IF MACHINE STOPS GOING UPHILL, STOP BLADE(S) AND BACK DOWNHILL SLOWLY.
- DO NOT MOW WHEN CHILDREN OR OTHERS ARE AROUND.
- NEVER CARRY CHILDREN, EVEN WITH BLADES OFF.
- LOOK DOWN AND BEHIND BEFORE AND WHILE BACKING.
- KEEP SAFETY DEVICES (GUARDS, SHIELDS, AND SWITCHES) IN PLACE AND WORKING.
- REMOVE OBJECTS THAT COULD BE THROWN BY THE BLADE(S).
- KNOW LOCATION AND FUNCTION OF ALL CONTROLS.
- BE SURE BLADE(S) AND ENGINE ARE STOPPED BEFORE PLACING HANDS OR FEET NEAR BLADE(S).
- BEFORE LEAVING OPERATOR'S POSITION, DISENGAGE BLADE(S), PLACE THE SHIFT LEVER IN NEUTRAL, ENGAGE BRAKE LOCK, SHUT ENGINE OFF AND REMOVE KEY.

READ OPERATOR'S MANUAL

Refer to **Leveling the Deck** on page 17 of this manual for more detailed instructions regarding various deck adjustments.

Starting the Engine



WARNING: Do not operate the tractor if the interlock system is malfunctioning. This system was designed for your safety and protection.

NOTE: Refer to the **TRACTOR SET-UP** on page 8 of this manual for Gasoline and Oil fill-up instructions.

- Insert the tractor key into the ignition switch.
- Place the PTO knob in the disengaged (OFF) position.
- Engage the tractor's parking brake.
- Pull the choke control outward.
- Turn the ignition key clockwise to the START position. After the engine starts, release the key. It will return to the ON position.

IMPORTANT: Do NOT hold the key in the START position for longer than ten seconds at a time. Doing so may cause damage to your engine's electric starter.

- After the engine starts, deactivate the choke control and place the throttle control in the FAST position.

NOTE: Do NOT leave the choke control on while operating the tractor. Doing so will result in a "rich" fuel mixture and cause the engine to run poorly.

Stopping the Engine



WARNING: If you strike a foreign object, stop the engine, disconnect the spark plug wire(s) and ground against the engine. Thoroughly inspect the machine for any damage. Repair the damage before restarting and operating

- If the blades are engaged, place the PTO knob in the disengaged (OFF) position.
- Turn the ignition key counterclockwise to the STOP position.
- Remove the key from the ignition switch to prevent unintended starting.

Driving The Tractor



WARNING: Avoid sudden starts, excessive speed and sudden stops.



WARNING: Do not leave the seat of the tractor without first placing the PTO knob in the disengaged (OFF) position, depressing the brake pedal and engaging the parking brake. If leaving the tractor unattended, also turn the ignition key off and remove the key.

- Briefly depress the brake pedal to release the parking brake. Move the throttle lever into the FAST (rabbit) position.
- To travel FORWARD, slowly depress the upper portion of the drive pedal forward until the desired speed is achieved. See Figure 9.

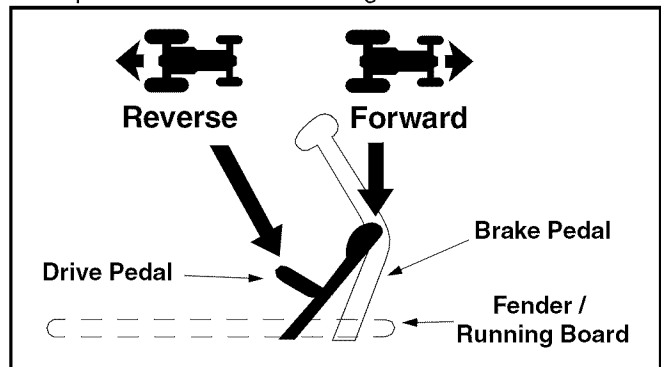

Figure 9

- To travel in REVERSE, check that the area behind is clear then slowly depress the lower portion of the drive pedal with the ball of your foot (NOT your heel) until the desired speed is achieved. See Figure 9.

IMPORTANT: Do NOT attempt to change the direction of travel when the tractor is in motion. Always bring the tractor to a **complete** stop before pivoting the drive pedal from forward to reverse or vice versa.

Engaging the Parking Brake

To engage the parking brake:

- Fully depress the brake pedal and hold it there while gently pushing the parking brake button inward.
- Hold the parking brake button in while removing your foot from the brake pedal.
- Once engaged, the parking brake button and the brake pedal will lock in the "down" position.

To disengage the parking brake:

- Slightly depress the brake pedal.

NOTE: *The parking brake must be engaged if the operator leaves the seat with the engine running or the engine will automatically shut off.*

Driving On Slopes

Refer to the **SLOPE GAUGE** on page 7 to help determine slopes where you may operate the tractor safely.



WARNING: Do not mow on inclines with a slope in excess of 15 degrees (a rise of approximately 2-1/2 feet every 10 feet). The tractor could overturn and cause serious injury.

- Mow up and down slopes, NEVER across.
- Exercise extreme caution when changing direction on slopes.
- Watch for holes, ruts, bumps, rocks, or other hidden objects. Uneven terrain could overturn the machine. Tall grass can hide obstacles.
- Avoid turns when driving on a slope. If a turn must be made, turn down the slope. Turning up a slope greatly increases the chance of a roll over.
- Avoid stopping when driving up a slope. If it is necessary to stop while driving up a slope, start up smoothly and carefully to reduce the possibility of flipping the tractor over backward.

Setting The Cruise Control

- Slowly depress the upper portion of the drive pedal until the desired speed is achieved.
- Lightly depress the cruise control button.
- While continuing to hold the cruise button in, lift your foot from the drive pedal (you should feel the cruise latch engage).
- Once engaged, the cruise control button and the drive pedal will lock in the “down” position, and the tractor will maintain the same forward speed.

NOTE: *Cruise control can not be engaged at the tractor's fastest ground speed. If the operator should attempt to do so, the tractor will automatically decelerate to the fastest optimal mowing ground speed.*

Disengage the cruise control using one of the following methods:

- Depress the brake pedal to disengage the cruise control and stop the tractor.
- Lightly depress the drive pedal.

To change the direction of travel to reverse when operating with cruise control, depress the brake pedal to disengage the cruise control and bring the tractor to a complete stop. Then depress the lower portion of the drive pedal with the ball of your foot to travel in reverse.

Moving The Tractor Manually

Your tractor's transmission is equipped with a hydrostatic relief valve for occasions when it is necessary to move the tractor manually. Activating this valve allows the rear tires to “freewheel.” To engage the hydrostatic relief valve, proceed as follows:

- Locate the hydrostatic bypass rod in the rear of the tractor. See Figure 10.

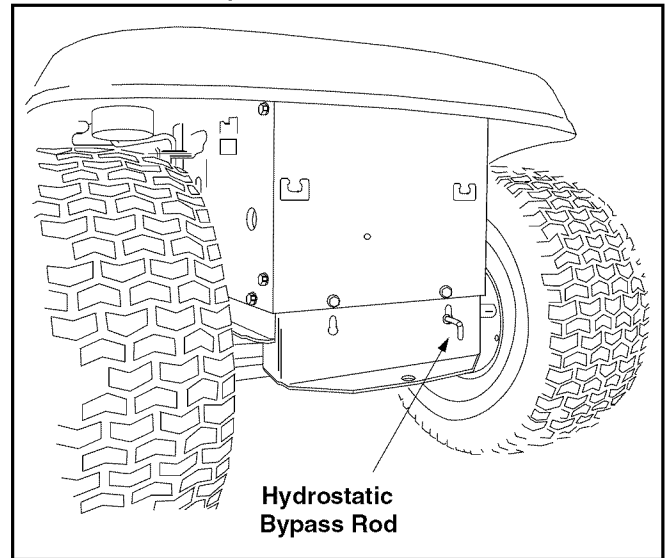

Figure 10

- Pull the hydrostatic bypass rod outward, then down, to lock it in place.

NOTE: *The transmission will NOT engage when the hydrostatic bypass rod is pulled out. Return the rod to its normal position prior to operating the tractor.*

IMPORTANT: Never attempt to move the tractor manually without first engaging the hydrostatic relief valve. Doing so will result in serious damage to the tractor's transmission.

Engaging the PTO

Engaging the PTO transfers power to the cutting deck or other (separately available) attachments. To engage the PTO, proceed as follows:

- Move the throttle control lever to the FAST (rabbit) position.

- Pull the PTO knob outward into the engaged (ON) position. See Figure 11.

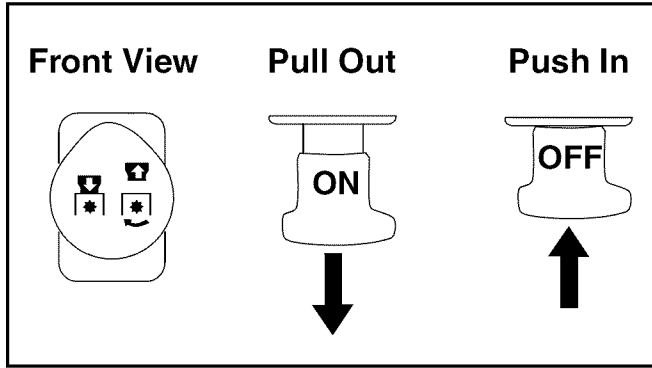

Figure 11

- Keep the throttle lever in the FAST (rabbit) position for the most efficient use of the cutting deck or other (separately available) attachments.

IMPORTANT: The electric PTO clutch will automatically shut off if the PTO is engaged with the shift lever in position for reverse travel with the ignition key in the **NORMAL MOWING** position. Refer to **Safety Interlock Switches** on page 13.

Using the Deck Lift Lever

To raise the cutting deck, move the deck lift lever to the left, then place it in the notch best suited for your application. Refer to **Setting The Cutting Height** earlier in this section.

Mowing



WARNING: To help avoid blade contact or a thrown object injury, keep bystanders, helpers, children and pets at least 75 feet from the machine while it is in operation. Stop machine if anyone enters the area.

The following information will be helpful when using the cutting deck with your tractor.



WARNING: Plan your mowing pattern to avoid discharge of materials toward roads, sidewalks, bystanders and the like. Also, avoid discharging material against a wall or obstruction which may cause discharged material to ricochet back toward the operator.

- Do not mow at high ground speed, especially if a mulch kit or grass collector is installed.
- For best results it is recommended that the first two laps be cut with the discharge thrown towards the center. After the first two laps, reverse the direction to throw the discharge to the outside for the balance of cutting. This will give a better appearance to the lawn.

- Do not cut the grass too short. Short grass invites weed growth and yellows quickly in dry weather.
- Mowing should always be done with the engine at full throttle.
- Under heavier conditions it may be necessary to go back over the cut area a second time to get a clean cut.
- Do NOT attempt to mow heavy brush and weeds and extremely tall grass. Your tractor is designed to mow lawns, NOT clear brush.
- Keep the blades sharp and replace the blades when worn. Refer to **Cutting Blades** on page 21 of this manual for proper blade sharpening instructions.

Mulching

This tractor comes equipped with a mulch kit which incorporates special blades, already standard on your tractor, in a process of recirculating grass clippings repeatedly beneath the cutting deck. The ultra-fine clippings are then forced back into the lawn where they act as a natural fertilizer. Observe the following points for the best results when mulching.

- Never attempt to mulch if the lawn is damp. Wet grass tends to stick to the underside of the cutting deck preventing proper mulching of the clippings.
- Do NOT attempt to mulch more than 1/3 the total height of the grass or approximately 1-1/2 inches. Doing so will cause the clippings to clump up beneath the deck and not be mulched effectively.
- Maintain a slow ground speed to allow the grass clippings more time to effectively be mulched.
- Always position the throttle control lever in the FAST (rabbit) position and allow it to remain there while mowing. Failing to keep the engine at full throttle places strain on the tractor's engine and does not allow the blades to properly mulch grass.

NOTE: *It is not necessary to remove the discharge chute to operate the mower with the mulch kit installed.*

To operate the cutting deck without mulching, simply remove the mulch plug and lower the discharge chute slowly. This will allow clippings to discharge from the side.

To reinstall the mulch plug, proceed as follows:

- Locate two rectangular holes on the cutting deck surface.

- Pivot the discharge chute up to access the deck opening. See Figure 12.

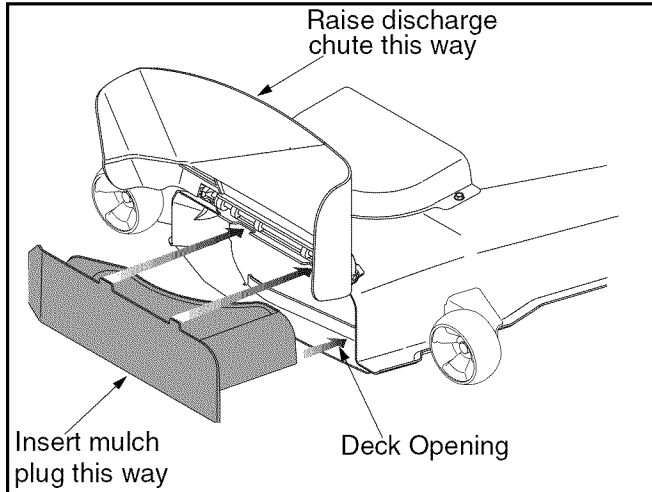

Figure 12

- Insert the mulch plug in the deck opening, aligning the edge of the plug with the deck as shown in the figure. Make sure the notches on the plug are in the slots on the deck opening.

- Lightly tab on the plug with your hand so that the notches fit properly under the chute tabs and the plug is secure.

Operating The Headlights

On some models, the lamps are ON whenever the tractor's engine is running. On other models, the lamps are ON whenever the ignition key is moved out of the STOP position.

On all models, the lamps turn OFF when the ignition key is moved to the STOP position.

NOTE: Never move the key into the Start position while the engine is running. Doing so may cause damage to your engine's electric starter.

SECTION 6: MAKING ADJUSTMENTS



WARNING: Never attempt to make any adjustments while the engine is running, except where specified in the operator's manual.

Leveling the Deck

NOTE: Check the tractor's tire pressure before performing any deck leveling adjustments. Refer to **Tires** on page 21 for information regarding tire pressure.

Front To Rear

The front of the cutting deck is supported by a stabilizer bar that can be adjusted to level the deck from front to rear. The front of the deck should be between 1/4-inch and 3/8-inch lower than the rear of the deck. Adjust if necessary as follows:

- With the tractor parked on a firm, level surface, place the deck lift lever in the top notch (highest position) and rotate the blade nearest the discharge chute so that it is parallel with the tractor.
- Measure the distance from the front of the blade tip to the ground and the rear of the blade tip to the ground.
- The first measurement taken should be between 1/4" and 3/8" less than the second measurement. Determine the approximate distance necessary for proper adjustment and proceed, if necessary, to the next step.

- Loosen the two jam nuts, if present, on the rear side of the deck stabilizer bracket.
- Locate the two lock nuts on the front side of the stabilizer bracket. See Figure 13. Tighten the lock nuts to raise the front of the deck; loosen the lock nuts to lower the front of the deck.

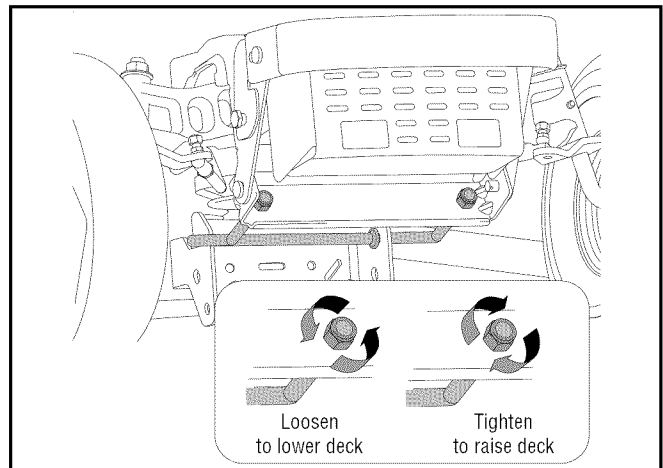

Figure 13

Side to Side

If the cutting deck appears to be mowing unevenly, a side to side adjustment can be performed. Adjust if necessary as follows:

- With the tractor parked on a firm, level surface, place the deck lift lever in the top notch (highest position) and rotate both blades so that they are perpendicular with the tractor.
- Measure the distance from the outside of the left blade tip to the ground and the distance from the outside of the right blade tip to the ground. Both measurements taken should be equal. If they're not, proceed to the next step.
- Loosen, but do NOT remove, the hex cap screw on the left deck hanger bracket. See Figure 14.

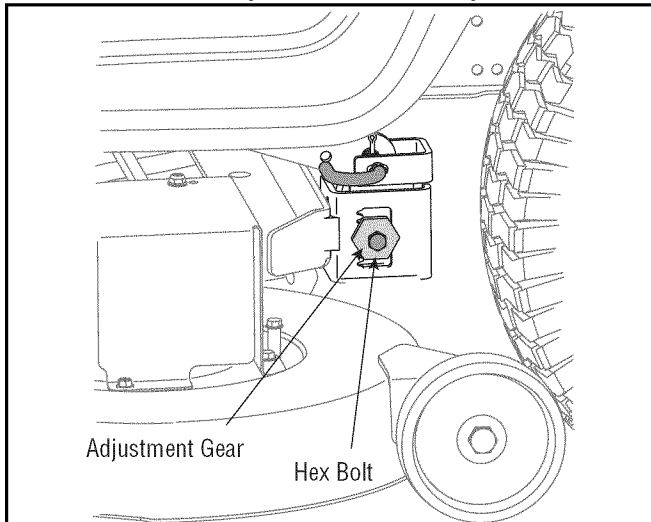

Figure 14

- Balance the deck by using a wrench to turn the adjustment gear (found immediately behind the hex cap screw just loosened) clockwise/up or counterclockwise/down.
- The deck is properly balanced when both blade tip measurements taken earlier are equal.
- Retighten the hex cap screw on the left deck hanger bracket when proper adjustment is achieved.

Parking Brake Adjustment



WARNING: Never attempt to adjust the brakes while the engine is running. Always disengage PTO, stop engine and remove key to prevent unintended starting.

If the tractor does not come to a complete stop when the brake pedal is completely depressed, or if the tractor's rear wheels can roll with the parking brake applied, the brake is in need of adjustment. The brake disc can be found on the right side of the transmission in the rear of the tractor. Adjust if necessary as follows:

- Looking at the transmission from the right side of the tractor, locate the compression spring and brake disc. See Figure 15.

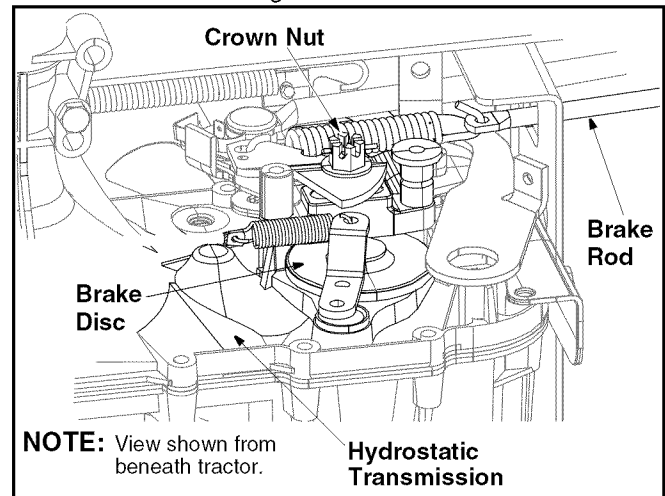

Figure 15

- Carefully remove the cotter pin from the crown nut on the right side of the brake assembly.
- Using a feeler gauge, check the gap between the brake disc and the brake puck. Proper gap is .011".
- Tighten the crown nut until the proper gap is achieved.
- Insert a replacement cotter pin (part number 714-0111) into the crown nut.

Seat Adjustment



WARNING: Before operating this machine, make sure the seat is engaged in the seat stop, stand behind the machine and pull back on seat until fully engaged into stop.

To adjust the position of the seat, move the lever to the left and slide the seat forward or rearward. Make sure seat is locked into position before operating the tractor.

Steering Adjustment

If the tractor turns tighter in one direction than the other, or if the ball joints are being replaced due to damage or wear, the steering drag links may need to be adjusted.

Adjust the drag links so that equal lengths are threaded into the ball joint on the left side and the ball joint on the right side:

- Loosen the jam nut found on the drag link at the rear of the ball joint. See Figure 16.
- Remove the hex nut and lock washer on the top of ball joint. See Figure 16.

- Thread the ball joint toward the jam nut to shorten the drag link. Thread the ball joint away from the jam nut to lengthen the drag link.

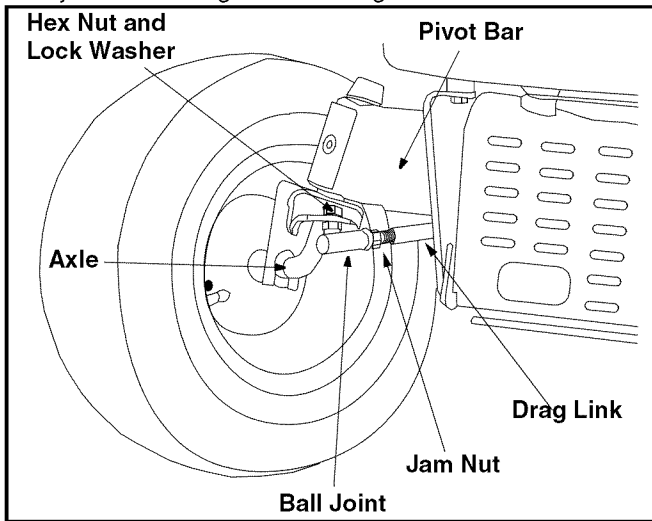

Figure 16

- Replace hex nut and lock washer and retighten the jam nut after proper adjustment is achieved.

NOTE: Threading the ball joints too far onto the drag links will cause the front tires to "toe-in" too far. Proper toe-in is between 1/16" and 5/16".

Front tire toe-in can be measured as follows:

- Place the steering wheel in position for straight ahead travel.
- In front of the axle, measure the distance horizontally from the inside of the left rim to the inside of the right rim. Note the distance.
- Behind the axle, measure the distance horizontally from the inside of the left rim to the inside of the right rim. Note the distance.
- The measurement taken in front of the axle should be between 1/16" and 5/16" less than the measurement taken behind the axle.
- Adjust if necessary.

SECTION 7: MAINTAINING YOUR LAWN TRACTOR



WARNING: Before performing any maintenance or repairs, disengage PTO, set parking brake, stop engine and remove key to prevent unintended starting.

Engine

Refer to the *Briggs & Stratton Operator/Owner Manual* (or *Kohler engine's Owner's Manual*) for engine maintenance instructions.

Check **engine oil level** before each use as instructed in the *Briggs & Stratton Operator/Owner Manual* (or *Kohler engine's Owner's Manual*) packed with your unit. **Follow the instructions carefully.**

Changing Engine Oil

NOTE: Depending on the engine model found on your tractor, it may be necessary to remove the tractor's side panel in order to replace the oil filter (if so equipped).

- Unscrew oil fill cap and remove dipstick from the oil fill tube. See Figure 17.
- Pop open the protective cap on the end of the oil drain valve to expose the drain port. See Figure 17.
- Push the oil drain hose (packed with this manual) onto the oil drain port. Route the opposite end of the hose into an appropriate oil collection container with a capacity of no less than 64 oz.
- Push the oil drain valve in slightly, then rotate counterclockwise and pull outward to begin draining oil. See Figure 17.

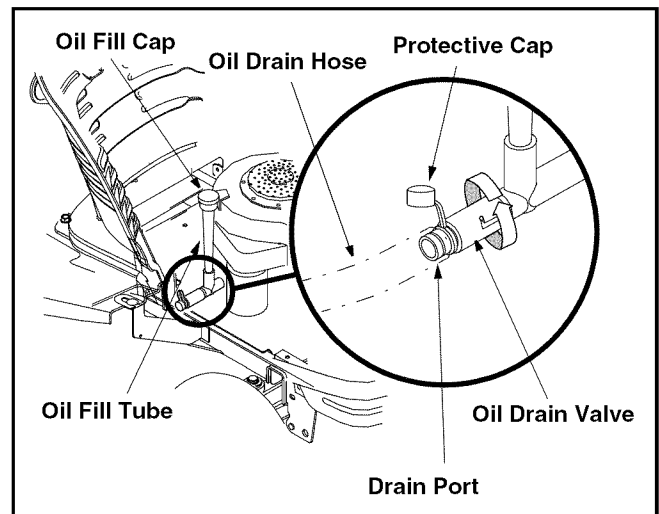

Figure 17

- Service the **oil filter** (if so equipped) as instructed in the separate *Briggs & Stratton Operator/Owner Manual* (or *Kohler engine's Owner's Manual*) packed with your unit.

Perform the above steps in the opposite order after oil has finished draining.

- Refill the engine with new motor oil.

IMPORTANT: Refer to the *Briggs & Stratton Operator/Owner Manual* (or *Kohler engine's Owner's Manual*) packed with your unit for information regarding the quantity and proper weight of motor oil.

Air Cleaner

Service the pre-cleaner, if so equipped, and cartridge/air cleaner element as instructed in the *Briggs & Stratton Operator/Owner Manual* (or *Kohler engine's Owner's Manual*) packed with your unit.

Spark Plug(s)

The spark plug(s) should be cleaned and the gap reset once a season. Spark plug replacement is recommended at the start of each mowing season. Refer to the *Briggs & Stratton Operator/Owner Manual* (or *Kohler engine's Owner's Manual*) for correct plug type and gap specifications.

Lubrication



WARNING: Before lubricating, repairing, or inspecting, always disengage PTO, set parking brake, stop engine and remove key to prevent unintended starting.

Engine

Lubricate the engine with motor oil as instructed in the *Briggs & Stratton Operator/Owner Manual* (or *Kohler engine's Owner's Manual*) packed with your unit.

Pivot Points & Linkage

Lubricate all the pivot points on the drive system, parking brake, and lift linkage at least once a season with light oil.

Rear Wheels

The rear wheels should be removed from the axles once a season. Lubricate the axles and the rims well with an all-purpose grease before re-installing them.

Front Axles

Each end of the tractor's front pivot bar may be equipped with a grease fitting. Lubricate with a grease gun after every 25 hours of tractor operation.

Transmission

The hydrostatic transmission is maintenance-free and sealed at the factory. The oil level cannot be checked nor can the oil be changed.

Cleaning the Engine And Deck

Any fuel or oil spilled on the machine should be wiped off promptly. Do NOT allow debris to accumulate around the cooling fins of the engine or on any other part of the machine, especially the belts and pulleys.

IMPORTANT: The use of a pressure washer or garden hose to clean your tractor is NOT recommended. It may cause damage to electrical components, spindles, pulleys, bearings or the engine. The use of water will result in a shortened life of the tractor and reduce its serviceability.

SECTION 8: SERVICE

Cutting Deck Removal

To remove the cutting deck, proceed as follows:

- Place the PTO (Blade Engage) knob in the disengaged (OFF) position and engage the parking brake.
- Lower the deck by moving the deck lift lever into the bottom notch on the right fender.
- Remove the deck/PTO belt from around the tractor's electric PTO clutch and idler pulleys. Refer to **Changing The Deck/ PTO Belt** and Figure 22.
- Looking at the cutting deck from the left side of the tractor, locate the deck support pin on the rear left side of deck. See Figure 18.

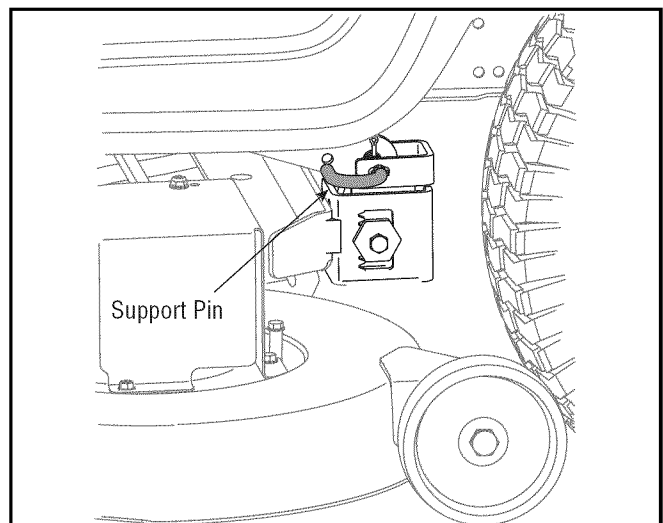

Figure 18

- Pull the deck support pin outward to release the deck from the deck lift arm.

- Rotate the pin slightly toward the rear of the tractor and release the pin into the hole provided.
- Repeat the above steps on the tractor's right side.
- Move the deck lift lever into the top notch on the right fender to raise the deck lift arms up and out of the way.
- Gently slide the cutting deck toward the front of the tractor allowing the hooks on the deck to release themselves from the deck stabilizer rod.
- Gently slide the cutting deck (from the right side) out from underneath the tractor.

Cutting Blades



WARNING: Be sure to shut the engine off, remove ignition key, disconnect the spark plug wire(s) and ground against the engine to prevent unintended starting before removing the cutting blade(s) for sharpening or replacement. Protect your hands by using heavy gloves or a rag to grasp the cutting blade.



WARNING: Periodically inspect the blade adapter and/or spindle for cracks or damage, especially if you strike a foreign object. Replace immediately if damaged.

The blades may be removed as follows.

- Remove the deck from beneath the tractor, (refer to **Cutting Deck Removal** above) then gently flip the deck over to expose its underside.
- Place a block of wood between the center deck housing baffle and the cutting blade to act as a stabilizer. See Figure 19.

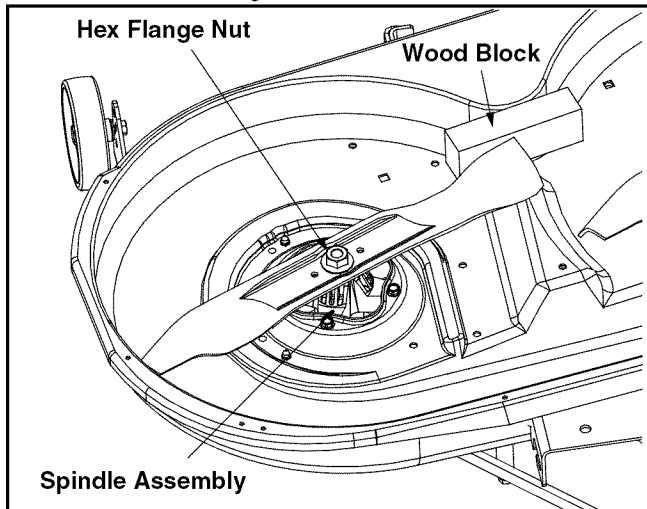

Figure 19

- Use a 15/16" wrench to remove the hex flange nut that secures the blade to the spindle assembly. See Figure 19.

To properly sharpen the cutting blades, remove equal amounts of metal from both ends of the blades along the cutting edges, parallel to the trailing edge, at a 25° to 30° angle. See Figure 20.

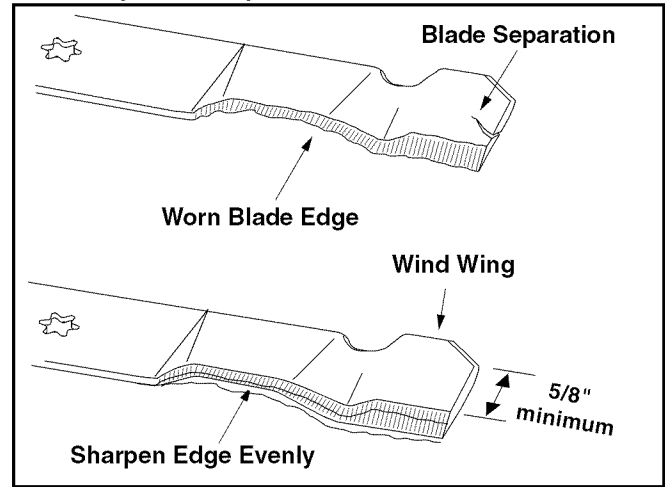

Figure 20

IMPORTANT: If the cutting edge of the blade has already been sharpened to within 5/8" of the wind wing radius, or if any metal separation is present, replace the blades with new ones. See Figure 20.

It is important that each cutting blade edge be ground equally to maintain proper blade balance.

A poorly balanced blade will cause excessive vibration and may cause damage to the tractor and result in personal injury.

The blade can be tested by balancing it on a round shaft screwdriver. Grind metal from the heavy side until it balances evenly.

When replacing the blade, be sure to install the blade with the side of the blade marked "Bottom" (or with a part number stamped in it) facing the ground when the mower is in the operating position.

IMPORTANT: Use a torque wrench to tighten the blade spindle hex flange nut to between 70 foot-pounds and 90 foot-pounds.

Tires



WARNING: Never exceed the maximum inflation pressure shown on the sidewall of the tire.

The recommended operating tire pressure is 10 psi for the rear tires and 14 psi for the front tires. Refer to the tire sidewall for exact tire manufacturer's recommended or maximum psi. Do not overinflate. Uneven tire pressure may cause the cutting deck to mow unevenly.

Battery

The battery is sealed and is maintenance-free. Acid levels cannot be checked.

- Always keep the battery cables and terminals clean and free of corrosive build-up.
- After cleaning the battery and terminals, apply a light coat of petroleum jelly or grease to both terminals.
- Always keep the rubber boot positioned over the positive terminal to prevent shorting.

IMPORTANT: If removing the battery for any reason, disconnect the NEGATIVE (Black) wire from its terminal first, followed by the POSITIVE (Red) wire. When re-installing the battery, always connect the POSITIVE (Red) wire its terminal first, followed by the NEGATIVE (Black) wire. Be certain that the wires are connected to the correct terminals; reversing them could change the polarity and cause damage to your engine's alternating system.

Charging

If the unit has not been put into use for an extended period of time, charge the battery with an automotive-type 12-volt charger for a minimum of one hour at six amps.



WARNING: Batteries give off an explosive gas while charging. Charge battery in a well ventilated area and keep away from an open flame or pilot light as on a water heater, space heater, furnace, clothes dryer or other gas appliances.

Jump Starting



WARNING: When removing or installing the battery, follow these instructions to prevent the screwdriver from shorting against the frame.

IMPORTANT: Never jump your tractor's dead battery with the battery of a running vehicle.

- Connect end of one jumper cable to the positive terminal of the good battery, then the other end to the positive terminal of the dead battery.
- Connect the other jumper cable to the negative terminal of the good battery, then to the **frame of the unit with the dead battery**.



WARNING: Failure to use this procedure could cause sparking, and the gas in either battery could explode.

Cleaning

Clean the battery by removing it from the tractor and washing with a baking soda and water solution. If necessary, scrape the battery terminals with a wire brush to remove deposits. Coat terminals and exposed wiring with grease or petroleum jelly to prevent corrosion.

Battery Failures

Some common causes for battery failure are:

- incorrect initial activation
- overcharging
- freezing
- undercharging
- corroded connections

These failures are NOT covered by your tractor's warranty.

Fuses

Two fuses are installed in your tractor's wiring harness to protect the tractor's electrical system from damage caused by excessive amperage.

If the electrical system does not function, or your tractor's engine will not crank, first check to be certain that the fuse has not blown.

One can be found under the hood mounted behind the top of the dash panel on the support bar. The other can be found under the seat mounted to the inside of the tractor frame next to the battery tray. Pull the fuse out and inspect it to determine if it is good or blown.



WARNING: Always use a fuse with the same amperage capacity for replacement.

Changing the Deck/PTO Belt



WARNING: Be sure to shut the engine off, remove ignition key, disconnect the spark plug wire(s) and ground against the engine to prevent unintended starting before removing the belt(s).

All belts on your tractor are subject to wear and should be replaced if any signs of wear are present.

IMPORTANT: The V-belts found on your tractor are specially designed to engage and disengage safely. A substitute (non-OEM) V-belt can be dangerous by not disengaging completely. For a proper working machine, use factory approved belts.

To change or replace the deck/PTO belt on your tractor, proceed as follows:

- Lower the deck by moving the deck lift lever into the bottom notch on the right fender.

- Remove the belt guards by removing the self-tapping screws that fasten them to the deck.
- To ease in removing the belt in later steps, loosen, but do not remove, the bolt which secures the pivoting idler pulley to the idler bracket. See Figure 21.

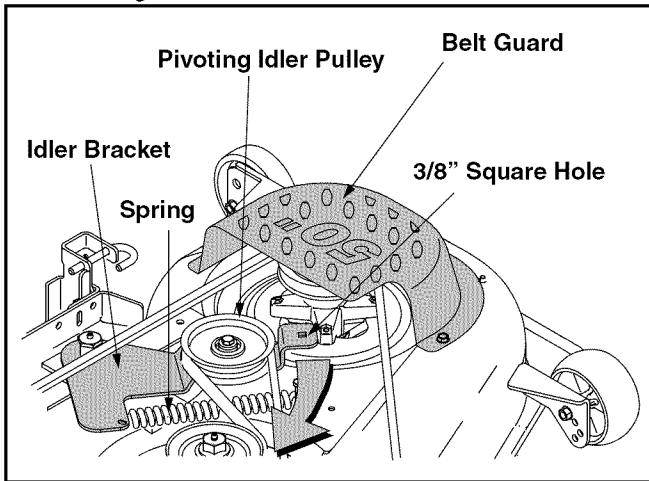

Figure 21

- Insert a 3/8"-drive ratchet wrench (set to *tighten*) into the square hole found in the idler bracket on the left side of the deck's surface. See Figure 21.
- Grasp the ratchet's handle and pivot it toward the tractor's right side to relieve tension on the belt.
- With belt tension relieved, **carefully remove the belt from around the left-hand spindle pulley.**



WARNING: Avoid the possibility of a pinching injury. Do not place your fingers on the idler spring or between the belt and a pulley while removing the belt.

IMPORTANT: Carefully allow the ratchet to pivot rearward before removing it from the square hole.

- Remove the belt from around all pulleys, including the deck idler pulley.
- Route the new belt as shown in and Figure 22.
- Remount the belt guards removed earlier.

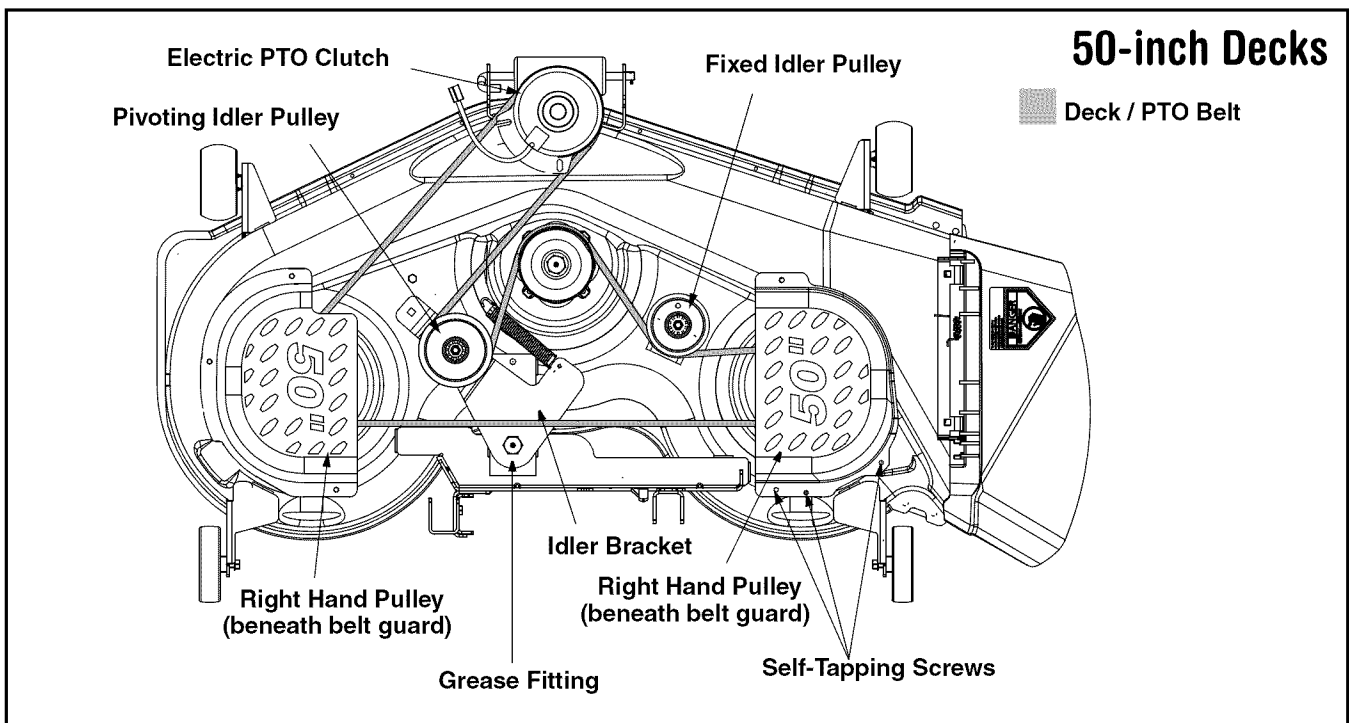

Figure 22

Changing the Transmission Drive Belts

Several components must be removed and special tools (i.e. air/impact wrench) in order to change the tractor's drive belts. See an authorized MTD Service Dealer to have your drive belts replaced or phone Customer Support as instructed on page 2 for information on ordering an MTD Service Manual.

Hydrostatic Transmission

The hydrostatic transmission is sealed at the factory and is maintenance free. The fluid level cannot be checked nor can the oil be changed. **Always** keep the area around the transmission cooling fan free of grass and debris at all times.

SECTION 9: OFF-SEASON STORAGE

Clean and lubricate the tractor as instructed in **Section 7: MAINTAINING YOUR LAWN TRACTOR** on page 19 of this manual before storing for an extended period.



WARNING: Drain fuel only into an approved container outdoors, away from an open flame. Allow engine to cool. Extinguish cigarettes, cigars, pipes, and other sources of ignition prior to draining fuel.

Follow the instructions in the **Service, Storage & Specifications** section of the *Briggs & Stratton* Operator/Owner Manual (or *Kohler* engines Manual) for proper engine care prior to storing your tractor.



WARNING: Never store the machine or fuel container indoors where there is an open flame, spark or pilot light such as on water heater, furnace, clothes dryer or other gas appliance.

SECTION 10: ATTACHMENTS & ACCESSORIES

The following attachments and accessories are compatible for **Lawn Tractor Model 615**. See the retailer from which you purchased your tractor, an authorized *MTD* Service Dealer or phone (800) 800-7310 for information regarding price and availability.

NOTE: *Lawn tractor model 615 is NOT designed for use with any type of ground-engaging attachments (e.g. tiller or plow). Use of this type of equipment WILL void the tractor's warranty.*

MODEL	DESCRIPTION
OEM-190-192	Triple Bagger Grass Collector (for 50-inch Decks)
OEM-190-218	Rear Weight Kit
OEM-190-604	Yard-Mate™ Storage Container/Toolbox (mounts on rear of tractor)*
OEM-190-607	Deluxe Tractor Sunshade*
OEM-190-658	Tire Chains
OEM-190-672	Grille Guard Bumper Kit (mounts on front of tractor)
OEM-190-032	42-inch Two-stage Snow Thrower
OEM-190-833	42-inch Front Dozer Blade

*Cannot be used with grass collector mounted.

SECTION 11: TROUBLESHOOTING

Trouble	Possible Cause(s)	Corrective Action
Engine fails to start	PTO knob engaged. Parking brake not engaged. Spark plug wire(s) disconnected. Throttle control lever not in correct starting position. Choke not activated. Fuel tank empty, or stale fuel. Blocked fuel line. Faulty spark plug. Engine flooded.	Disengage PTO. Engage parking brake. Connect wire(s) to spark plug. Place throttle lever to FAST position. Pull out the CHOKE control. Fill tank with clean, fresh (less than 30 days old) gas. Clean fuel line or replace fuel filter, if so equipped. Clean, adjust gap or replace plug. Crank engine with throttle in FAST position.
Engine runs erratic	Unit running with CHOKE applied. Spark plug wire(s) loose. Blocked fuel line or stale fuel. Vent in gas cap plugged. Water or dirt in fuel system. Dirty air cleaner.	Deactivate CHOKE. Connect and tighten spark plug wire(s). Clean fuel line; fill tank with clean, fresh (less than 30 days old) gasoline. Replace fuel filter, if so equipped. Clear vent or replace cap if damaged. Drain fuel tank. Refill with clean, fresh (less than 30 days old) gasoline. Replace air cleaner cartridge/element or clean pre-cleaner, if so equipped.
Engine overheats	Engine oil level low. Air flow restricted.	Fill crankcase with proper capacity and weight of oil. Clean grass clippings and debris from around the engine's cooling fins and blower housing.
Engine hesitates at high RPM	Spark plug gap too close.	Remove spark plug and reset the gap.
Idles poorly	Spark plug fouled, faulty or gap too wide. Dirty air cleaner.	Replace spark plug. Set plug gap. Replace air cleaner cartridge/element or clean pre-cleaner, if so equipped.
Excessive vibration	Cutting blade loose or unbalanced. Damaged or bent cutting blade.	Tighten blade and spindle. Balance blade. Replace blade.
Uneven cut	Deck not balanced properly. Dull blade. Uneven tire pressure.	Perform side-to-side deck adjustment. Sharpen or replace blade. Check tire pressure in all four tires.

NOTES

SECTION 12: ILLUSTRATED PARTS LIST

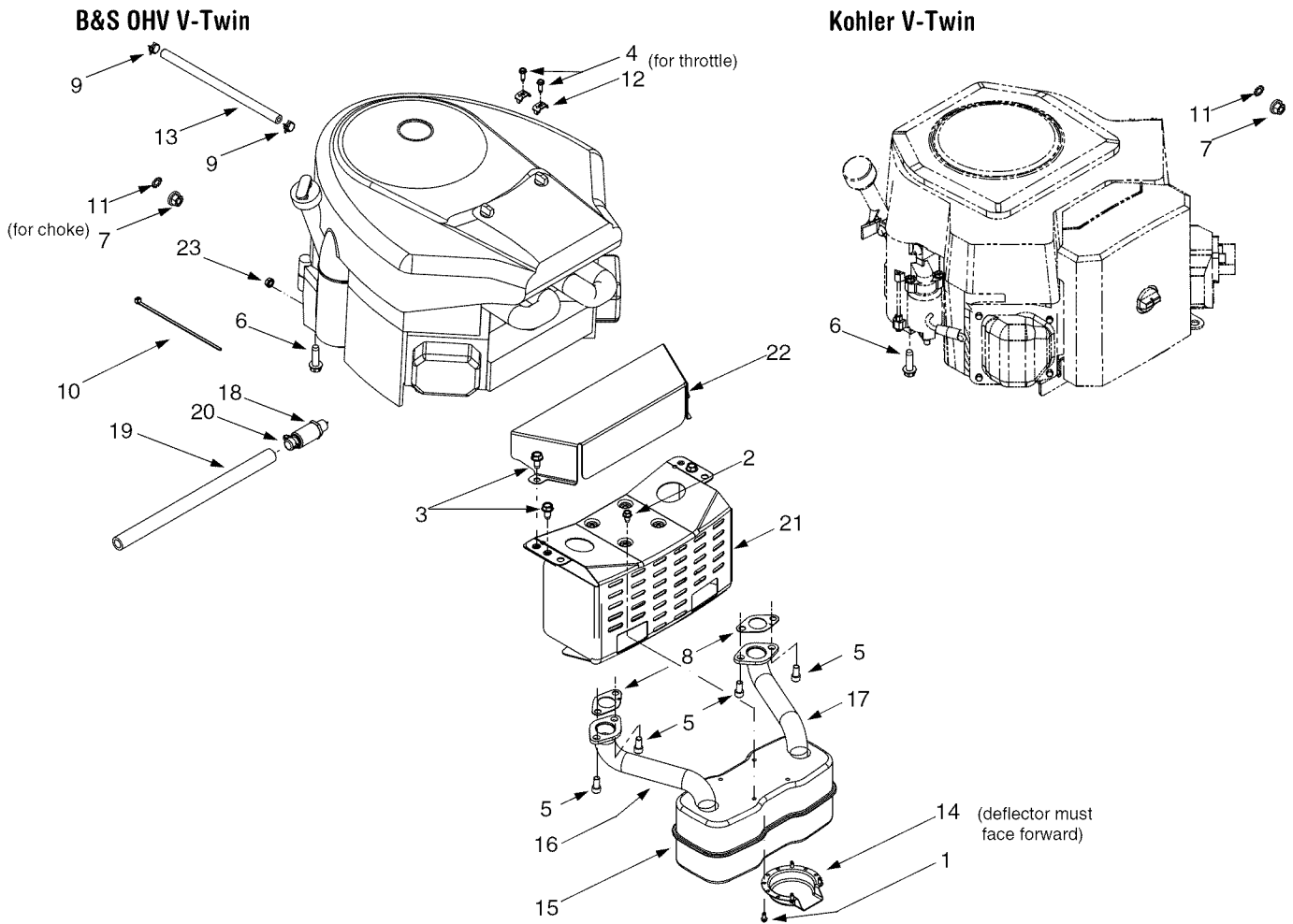

Ref. No.	Part No.	Description	Ref. No.	Part No.	Description
1	710-0227	Self-tapping Screw, #8-18 x.50	14	751-0564A	Muffler Deflector
2	710-0599	Self-tapping Screw, 1/4-20 x.50	15	751-0616A	Muffler, Twin Inlet (B&S OHV V-Twin)
3	710-0726	Self-tapping Screw, 5/16-18 x.625	15	751-0805	Muffler, Twin Inlet (Kohler V-Twin)
4	710-1237	Screw, #10-32 x.625 (B&S OHV V-Twin)	16	751-0650B	RH Exhaust Pipe (B&S OHV V-Twin)
5	710-1314A	Screw, 5/16-18 x.625 (B&S OHV V-Twin)	16	751-0645A	RH Exhaust Pipe (Kohler V-Twin)
6	710-1315	Self-tapping Screw, 3/8-16 x 1.25	17	751-0651B	LH Exhaust Pipe (B&S OHV V-Twin)
7	712-3005	Flange Lock Nut, 3/8-16	17	751-0644B	LH Exhaust Pipe (Kohler V-Twin)
8	721-0460	Exhaust Gasket (B&S OHV V-Twin)	18	751-3140	Oil Drain Valve
9	726-0205	Hose Clamp	19	751-3141	Oil Drain Hose
10	725-0157	Cable Tie	20	751-3142	Oil Drain Cap
11	736-0300	Lock Washer,.406 x.875 x.059	21	783-0615D	Muffler Heat Shield
12	751B221535	Casing Clamp (B&S OHV V-Twin)	22	783-0625C	Engine Heat Shield (B&S OHV V-Twin)
13	751-0535	Fuel Line Hose	23	712-0271	Hex Nut, 1/4-20 (B&S OHV V-Twin)

Model 615

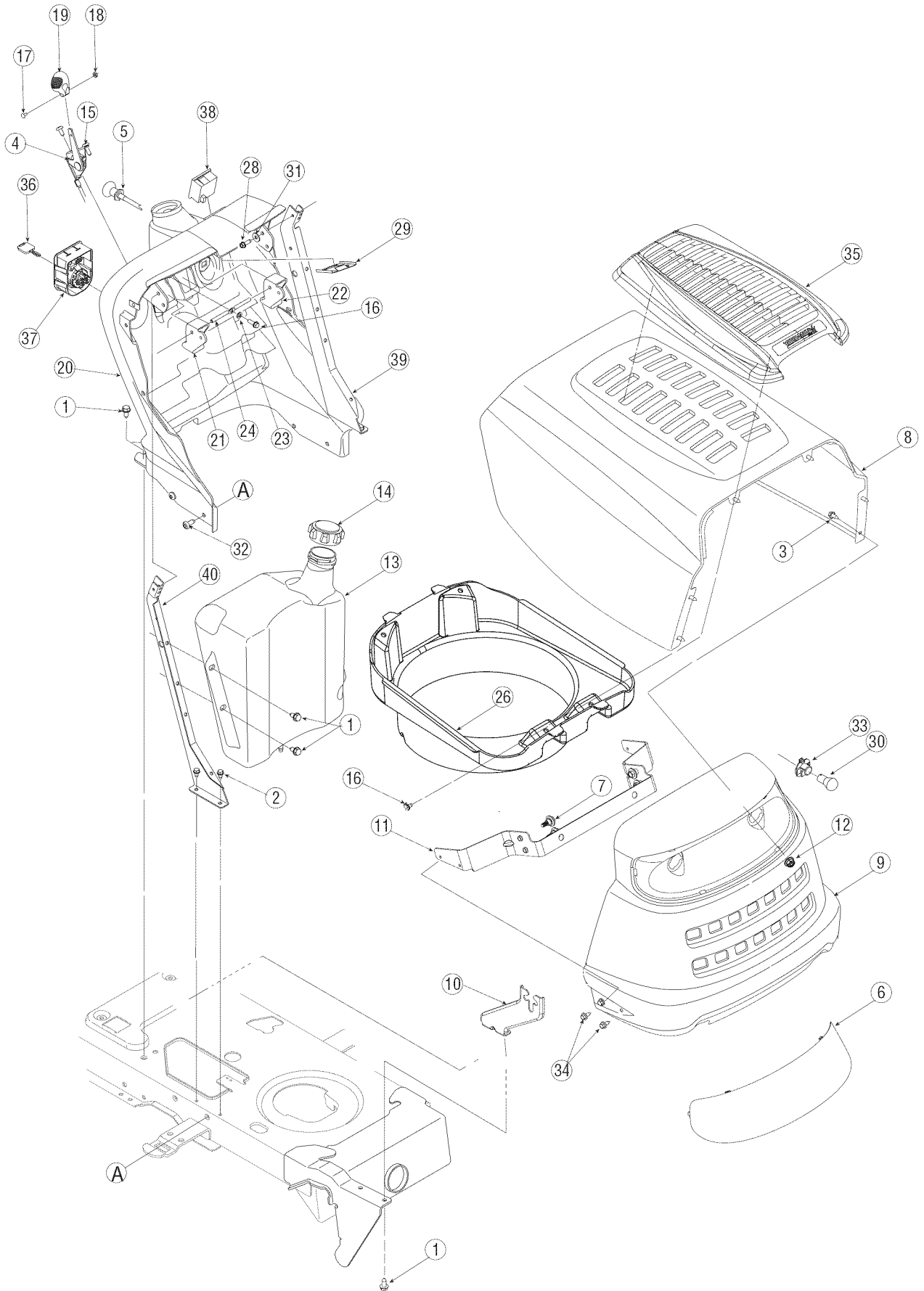

Model 615

Ref. No.	Part No.	Description	Ref. No.	Part No.	Description
1.	710-0726	Screw, 5/16-12 x.750	22.	731-04217	Parking Brake Button
2.	710-0599	Self-tapping Screw, 1/4-20 x.5	23.	736-0142	Flat Washer, 9/32 x 1/2 x 1/16
3.	710-0751	Hex Cap Screw, 1/4-20 x.62	24.	747-1196	Brake/Cruise Pivot Rod
4.	746-1086	Throttle Cable	25.	629-04083†	Headlight Wire Harness
5.	746-1085A	Choke Knob/Cable	26.	731-05165	Hood Plenum
6.	731-04949	Headlight Lens	27.	725-1752†	Electric PTO Switch
7.	738-04091	Shoulder Screw,.43 x.29	28.	710-0642	Self-tapping Screw, 1/4-20 x.75
8.	783-04551	Hood, 1 Style	29.	783-0462	Switch Brkt., Electric PTO
9.	783-04552	Grill, 1 Style	30.	725-0963	Lamp
10.	783-04578	Pivot Bracket - RH	31.	736-0270	Bell Washer,.265 x.75 x.062
	783-04577	Pivot Bracket - LH	32.	710-1611B	Screw, 5/16-18 x.75
11.	783-04621	Grill Pivot Bracket	33.	725-1649	Headlight Socket
12.	712-04064	Flange Lock Nut, 1/4-20	34.	710-1652	Hex Index Screw, 1/4-20 x.625
13.	751-0658E	Fuel Tank, Three Gallon	35.	731-05173	Hood Cover, 5 Style
14.	751-0603	Fuel Cap	36.	725-1745	Ignition Key w/ plastic cover
15.	710-1017	Screw, 1/4-14 x.625		725-1744	Ignition Key w/o plastic cover
16.	710-0895	Self-tapping Screw, 1/4-15 x.75	37.	725-04227	Ignition Switch
17.	710-3217	Truss Phillips Screw, #8-32 x.375	38.	725-04036A	Systems Ind. Monitor w/ Hour Meter
18.	712-0142	Hex Nut, #8-32	39.	783-04323B	LH Dash Support Plate
19.	731-1857	Throttle Control Knob	40.	783-04285B	RH Dash Support Plate
20.	731-05005	Dash Panel (Models w/ Electric PTO)	—	629-04104†	Wire Harness (B&S Intek Twin)
21.	731-04215	Cruise Control Button	—	629-04137†	Wire Harness (Kohler Twin)

† Not Shown

Model 615

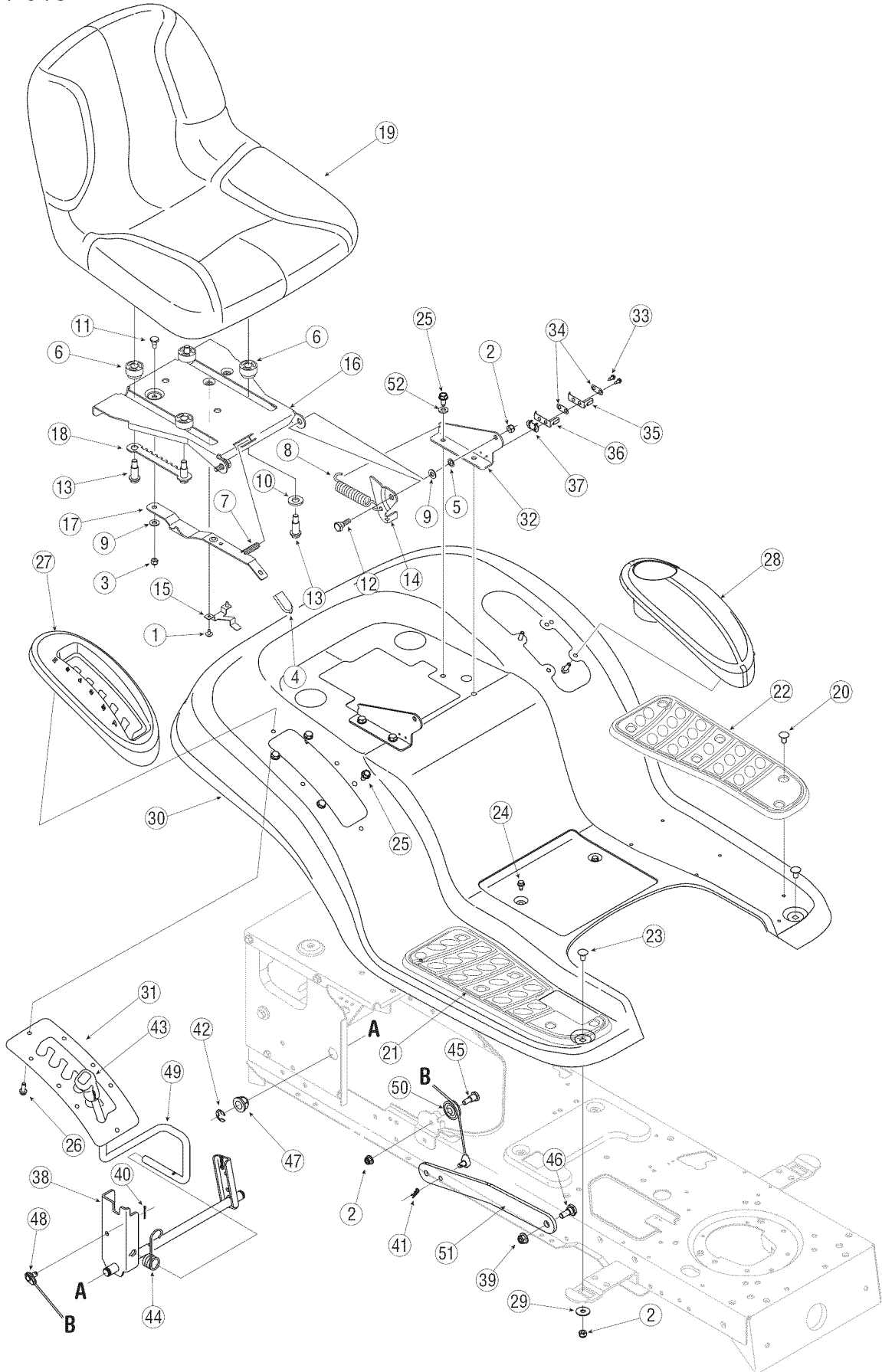

Model 615

REF. NO.	PART NO.	DESCRIPTION
1	710-1268	Screw, #10-16 x.375
2	712-04063	Nut, Flange Lock, 5/16-18, GrF, Nylon
3	712-3027	Nut, Flange Lock, 1/4-20
4	720-0309A	Seat Adjuster Grip
5	726-0201	Nut, Speed,.3125 ID
6	731-04074	Spacer
7	732-0499	Compression Spring,.41 x 1.5
8	732-1184	Spring, Extension,.84 Dia. x 4.6
9	736-0275	Wash, Flat,.344 x.688 x.065
10	736-3019	Wash, Flat,.531x 1.062 x.134
11	738-0137A	Screw, Shoulder,.340 x.285,1/4-20
12	738-0296	Screw, Shoulder,.437 x.268, 5/16-18
13	738-0966	Screw, Shoulder,.50 x.925, 3/8-16
14	783-0209C	Seat Bracket, Lift
15	783-0611	Seat Stop
16	783-0738B	Seat Pivot Bracket
17	783-0739A	Seat Adjustment Lever
18	783-0753	Seat Adjustment Selector
19	757-04012B	High Back Seat, Yellow
20	726-3046	Ratchet Clip
21	735-0656	RH Foot Pad, Rubber
22	735-0657	LH Foot Pad, Rubber
23	710-0260A	Bolt, Carriage, 5/16-18,.62, Gr1
24	710-0599	Screw, 1/4-20, 0.500
25	710-0726	Screw, 5/16-12, 0.750
26	710-0895	Screw, 1/4-15, 0.750
27	731-1990	Cover, Lift Lever
28	731-1993A	Cover, w/ Cup Holder
29	736-3078	Washer, Flat,.344 x 1.0 x.063
30	783-04333A	Fender
31	783-0677	Adjustment Bracket, Lift
32	783-1489A	Mounting Bracket, Seat
33	710-0227	Screw, #8-18 x.50
34	726-0279	Plate, Insulator
35	725-1303	Spring Switch, Outer
36	725-1439	Spring Switch, Inner
37	726-0278	Plate, Insulator Boss
38	683-04079	Shaft Assembly, Lift
39	712-04065	Nut, Flange Lock, 3/8-16, GrF, Nylon
40	714-0104	Pin, Cotter,.072 Dia. x 1.13
41	714-0111	Pin, Cotter, 3/32, 1.0
42	716-0106A	Ring, E Type,.625 Dia.
43	720-0311	Grip, Handle, 1/2
44	732-0874	Spring, Torsion
45	738-0138A	Screw, 5/16-18 x.620 Gr2
46	738-0380	Screw, Shld,.50 x.27, 3/8-16
47	741-0225	Bearing, Hex Flange
48	746-0968	Cable, Lift, 16.16
49	747-04155	Handle, Lift
50	756-1154	Pulley, Roller
51	783-0678A	Arm, Lift
52	736-0607	Lock Washer, 5/16

Model 615

REF. NO.	PART NO.	DESCRIPTION
1	710-04095	Hex Screw, 3/8-16, 1.00, Gr5
2	710-0514	Hex Screw, 3/8-16, 1.00, Gr5
3	710-0643	Hex Screw, 5/16-18, 1.00, Gr5
4	711-1408	Link, Drag, RH
5	711-1409A	Link, Drag, LH
6	712-0214	Nut, Hex Lock, 3/8-24
7	712-04065	Nut, Flange Lock, 3/8-16, Grf, Nylon
8	712-0459	Nut, Flange Lock, 7/16-20
9	712-3004A	Nut, Flange Lock, 5/16-18, Gr5
10	712-0240	Nut, Jam, 7/16-20, Gr2
11	717-1550E	Gear, Steering, 11/90 Ratio
12	717-1554	Gear, Pinion, Steering
13	723-0448A	Ball Joint, 7/16-20, Lock
14	736-3004	Washer, Flat,.406 x.875 x.105
15	736-3084	Washer, Flat,.51 x 1.12 x.06
16	710-0726	Screw, 5/16-12, 0.750
17	738-04154	Spacer, Shoulder,.38 x 1.00 x.31
18	738-1001A	Shaft, Steering,.625 OD x 24.25 Lg
19	741-0475	Plastic Bushing.380 ID
20	738-0143	Screw, Shoulder,.498 x.340, 3/8-16
21	783-0726D	Pivot Bracket, Support RH
22	783-0727C	Pivot Bracket, Support LH
23	783-0728	Pivot Bracket, Bar
24	631-04008	Steering Wheel, 3 Spoke, Soft Grip
25	731-04065	Steering Wheel Cover
26	738-1011A	Shlder Screw,.5 x 2.2, 3/8-16
27	734-2290A	Deluxe Hub Cap
28	736-0316	Flat Washer,.78 x 1.589 x.06
29	714-04039	Cotter Pin, 5/32 x 1.25
30	719-04105	Cast Iron Pivot Bar
31	726-0341	Push Cap
32	638-04003	LH Axle Assembly,.750
33	638-04004	RH Axle Assembly,.750
34	711-0332	Pin, Clevis,.50 x.78
35	714-04023	Cotter Pin, Inter,.080 x 1.5625
36	783-0720A	Front Adjustment Bracket
37	741-0656A	Hex Flange Bearing
38	634-04087	Wheel Assembly Complete, 15 x 6
	734-04040	Tire Only 15 x 6 x 6
	634-04081	Rim Only w/ Valve Stem

Model 615

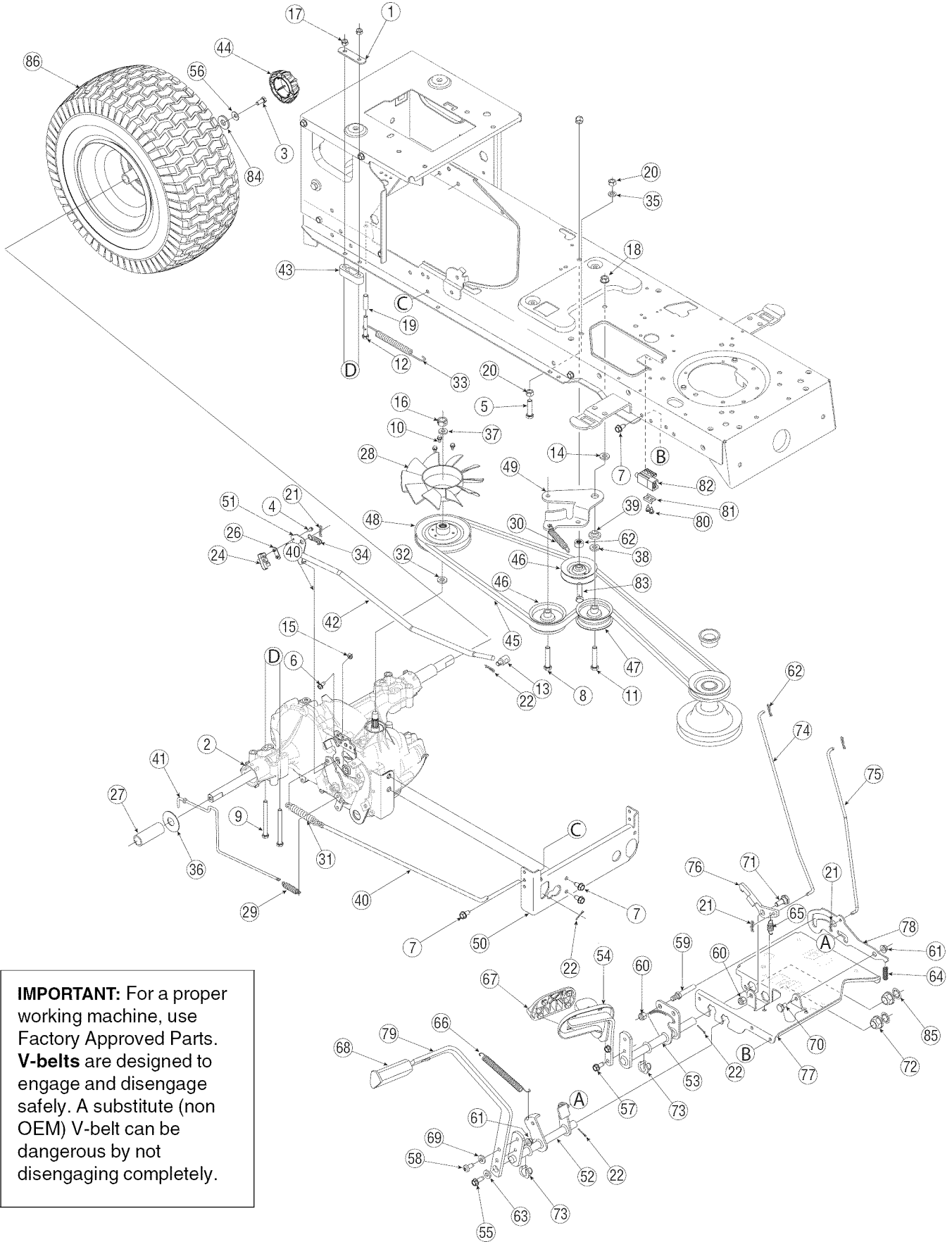

IMPORTANT: For a proper working machine, use Factory Approved Parts. **V-belts** are designed to engage and disengage safely. A substitute (non OEM) V-belt can be dangerous by not disengaging completely.

Model 615

Ref. No.	Part No.	Description	Ref. No.	Part No.	Description
1	17840	Transmission Mounting Bracket	45	754-0461	V Belt, A x 78" Lg
2	618-0319	Hydrostatic Transmission	46	756-0116A	Idler Pulley
3	710-0627	Screw, 5/16-24 x.750	47	756-0981B	Flat Idler Pulley
4	710-0227	AB Screw #8-18 x 0.5	48	756-04111	Input Pulley
5	710-0344	Hex Bolt 3/8-16 x 1.5	49	783-04442	Idler Bracket
6	710-0599	TT Screw 1/4-20 x 0.5	50	783-0810B	Torq Bracket
7	710-0726	AB Screw 5/16-12 x 0.75	51	783-1019	Actuator Bracket
8	710-0502A	TT Sems Screw 3/8-16 x 1.250	52	647-0031B	Brake Control Assembly
9	710-1266	Hex Bolt 5/16-18 x 3.5	53	647-0049A	Hydrostatic Control Assembly
10	710-3007	Carriage Screw	54	683-0267C	Pedal Assembly
11	710-3011	Hex Bolt 3/8-16 x 2.25	55	710-0650	TT Screw 5/16-18 x 0.875
12	710-0809	Screw, 1/4-20 x 1.250	56	736-0242	Bell Washer,.340 x.872 x.060
13	711-0832	Ferrule	57	710-1260A	LD Screw 5/16-18 x 0.75
14	736-0320	Flat Washer,.38 x 1.38 x.125	58	710-1611B	TT Screw 5/16-18 x 0.75
15	712-0291	Hex Lock Nut 1/4-20	59	711-04159B	Pin
16	712-3066	Hex Nut, 1/2-20	60	712-04065	Flange Lock Nut, 3/8-16
17	712-04063	Flange Lock Nut, 5/16-18	61	712-3004A	Flange Lock Nut, 5/16-18
18	712-0431	Flanged Lock Nut 3/8-16	62	750-0535	Spacer,.380ID x.625OD x.21
19	750-0566A	Spacer,.260 x.372 x 1.030 Lg	63	736-0119	Lock Washer, 5/16
20	712-3017	Hex Nut 3/8-16	64	732-0335	Compression Spring
21	714-0104	Cotter Pin	65	732-0955	Extension Spring
22	714-0111	Cotter Pin	66	732-0963	Extension Spring
23	725-0157	Cable Tie (not shown)	67	735-0662	Control Pedal
24	725-1644	Switch	68	735-3049	Brake Control Pedal
25	726-0154	Cable Tie (Not shown)	69	736-3008	Flat Washer
26	726-0320	Insulator Nut Plate	70	738-0155	Shoulder Screw
27	731-04682	Sleve, 0.758 x 0.821 x 1.5	71	738-0380	Shoulder Screw
28	731-1449A	Blade Fan	72	741-0225	Hex Flange Bearing
29	732-0209	Extension Spring	73	741-3065B	Hex Flange Bearing
30	732-0429A	Extension Spring	74	747-04093	Brake Lock Control Rod
31	732-0716	Extension Spring	75	747-04096	Cruise Control Rod
32	732-0729	Wire Ring	76	748-04039B	Cruise Latch
33	732-0994	Extension Spring	77	783-04612	Steering Support Bracket
34	732-3118	Extension Spring	78	683-04185	Lockout Bracket
35	736-0169	Lock Washer	79	783-0773A	Brake Pedal
36	736-0866	Flat Washer	80	710-0224	Screw, #10-16 x.500
37	736-0921	Lock Washer	81	17962	Switch Plate
38	736-3010	Flat Washer	82	725-04039	Interlock Switch
39	738-0372B	Shoulder Spacer	83	710-1007	Screw, 3/8-16 x 1.500
40	747-04139	Brake Rod	84	736-0430	Flat Washer,.350 x 1.59 x.062
41	747-1149	Bypass Rod	85	736-0187	Flat Washer,.64 x 1.24 x.06
42	747-1151	Control Rod	86	634-0177	Wheel Complete, 20 x 10 x 8
43	748-0334	Transaxle Spacer		734-1873	Tire Only, 20 x 10 x 8
44	731-2290A	Hub Cap		634-0070	Rim Only

Model 615

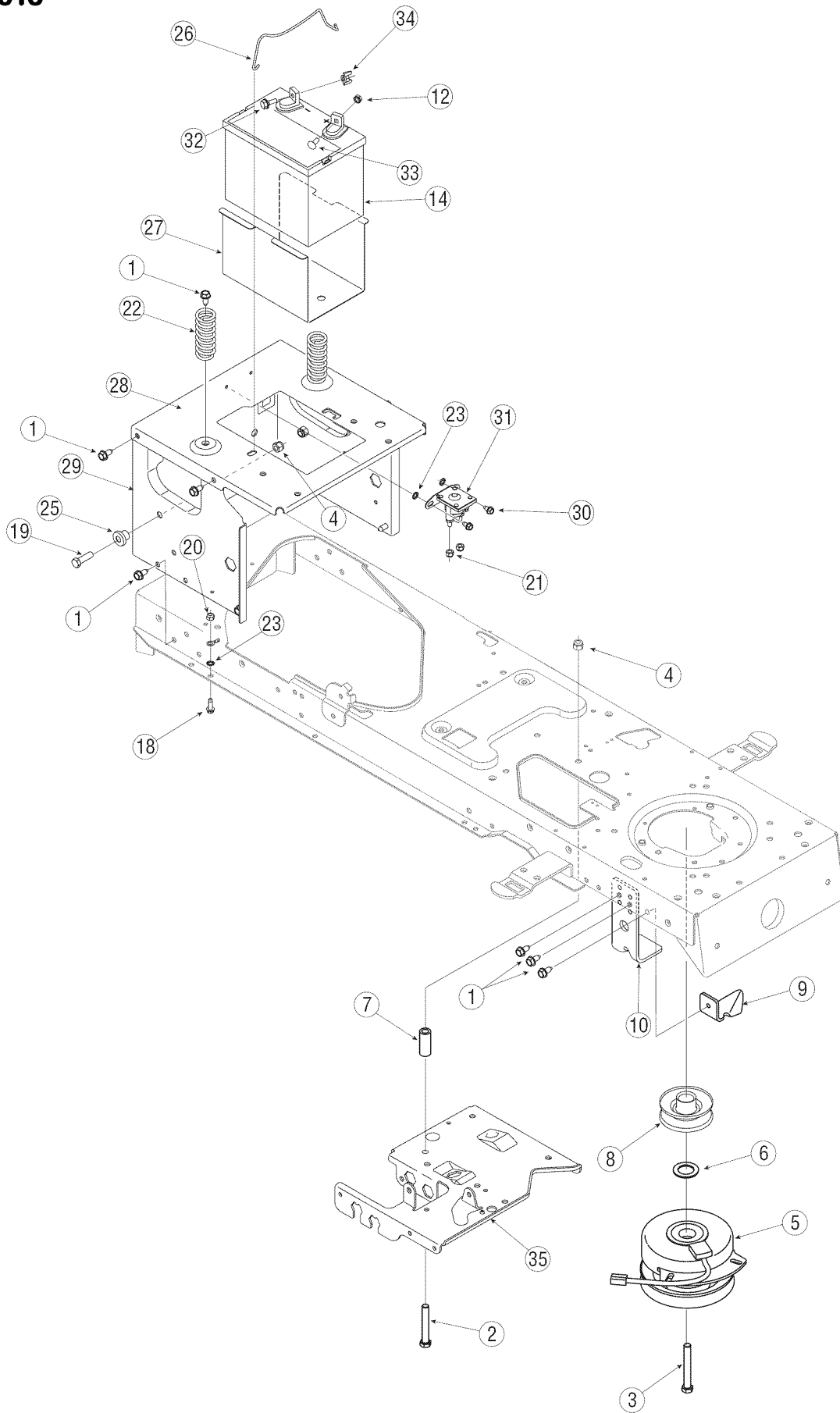

Model 615

REF. NO.	PART NO.	DESCRIPTION
1	710-0726	Screw, 5/16-12, 0.75
2	710-0859	Screw, 3/8-16, 2.50, Gr5
3	710-3157A	Screw, 7/16-20, 3.25, Gr5, Lock
4	712-04065	Nut, Flange Lock, 3/8-16, GrF, Nylon
5	717-04174	PTO Clutch, Electric
6	736-0277	Washer, Flat, 1.031 x 1.620 x.095
7	748-0415B	Spacer,.385 ID x.635 OD x 1.54
8	756-0639A	Pulley, Engine, 3.56 Diameter
9	783-04419A	Clutch Bracket
10	783-04467	Deck Bracket, Up-Stop
11	710-0703	Screw, Carriage, 1/4-20,.75, Gr5
12	712-0271	Nut, Sems, 1/4-20
13	712-3087	Nut, Wing, 1/4-20
14	725-1750A	Battery, 235 CCA
15	738-1132	Screw, Shoulder,.250 x.150, 1/4-20
16	683-04173	Frame Assembly, Lower
17	710-0607	Screw, 5/16-18, 0.500
18	710-0642	Screw, 1/4-20, 0.750
19	710-3005	Screw, 3/8-16, 1.25, Gr5
20	712-04064	Nut, Flange Lock, 1/4-20, GrF, Nylon
21	712-3006	Nut, Hex, 1/4-20, Gr5 (B&S Intek Twin)
22	732-04035	Spring, Compression, 1.28 OD x 3.125
23	736-0222	Washer, Lock, 1/4, External
24	736-0329	Washer, Lock, 1/4
25	738-04058	Spacer, Shoulder,.38 x 1.0 x.70
26	747-04121A	Hold Rod, Battery
27	783-0349	Battery Tray
28	783-04329A	Seat Bracket, Frame
29	783-04375A	Frame, Upper
30	710-0599	Screw, 1/4-20, 0.50 (B&S Intek Twin)
31	725-1426A	Solenoid, 12V, 100 Amp (B&S Intek Twin)
32	738-1132	Screw, Shoulder,.250 x.15, 1/4-20
33	710-0703	Screw, Carriage, 1/4-20,.75
34	712-3087	Nut, Wing, 1/4-20
35	783-04612	Support Bracket, Steering

Model 615

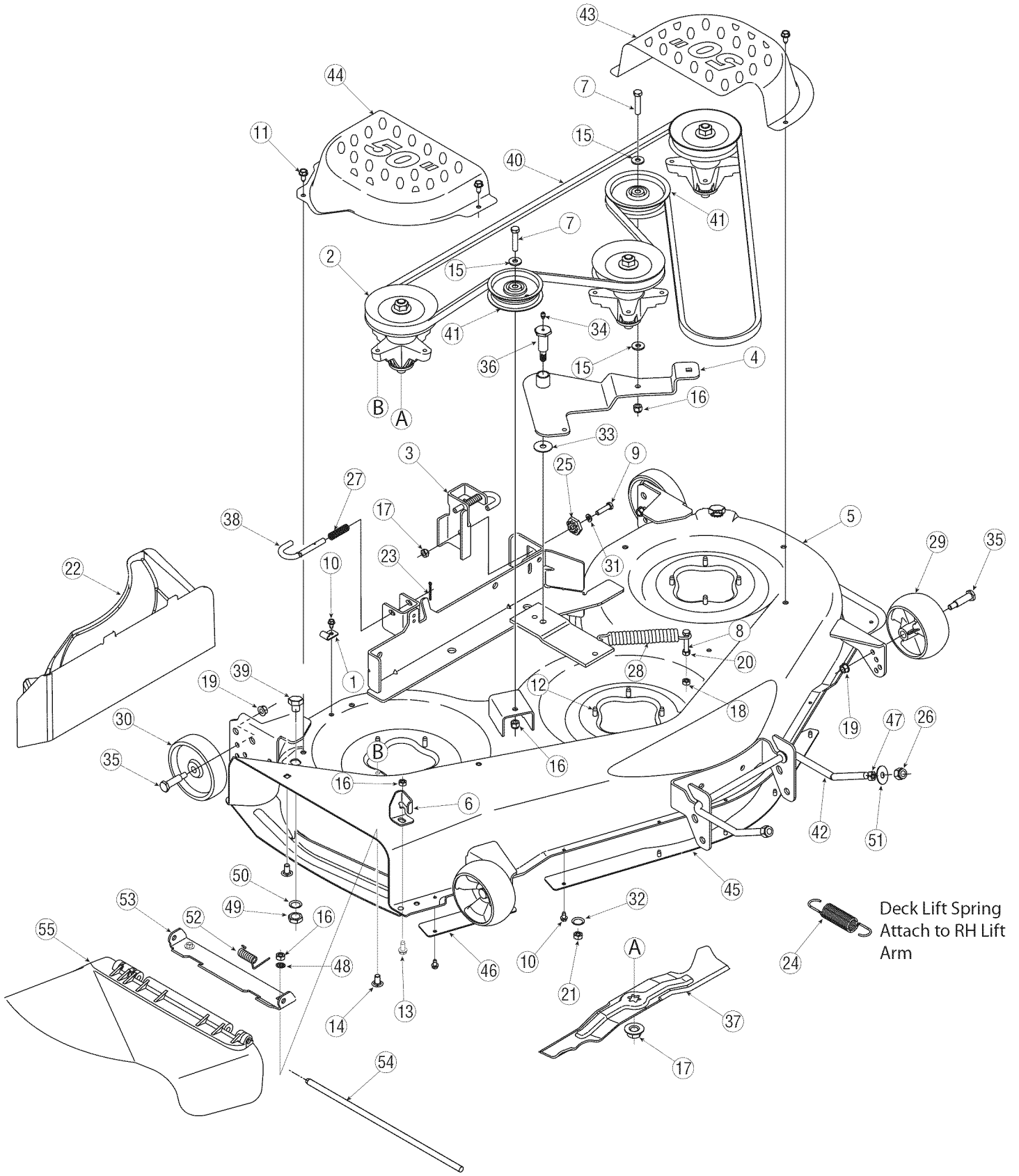

Model 615

REF. NO.	PART NO.	DESCRIPTION	REF. NO.	PART NO.	DESCRIPTION
1	16606	Hook, Retainer	29	734-04039	Deck Wheel, 5.0
2	618-04125	Spindle Assembly	30	734-0973	Deck Wheel, 5.0
3	683-0254B	Hanger Bracket Assembly	31	736-0119	Washer, Lock, 5/16, Regular Duty
4	683-04098	Idler Bracket	32	736-0407	Washer, Bell, .45 x 1.0 x.062
5	683-04075	Weldment, 50-inch Deck	33	736-0406	Washer, Flat, .442 x 1.38 x.060
6	703-3279	Chute Stop	34	737-3000	Fitting, Lube, 3/16
7	710-0347	Screw, 3/8-16, 1.75	35	738-0373	Shoulder Screw
8	710-3103	Screw, 5/16-18 x 2.00	36	738-3005A	Screw, Shoulder, .68 x 1.59
9	710-0528	Screw, 5/16-18, 1.25, Gr5	37	742-04053A	Blade
10	710-0599	Screw, 1/4-20 x 0.5	38	747-1116	Rod, Handle, Deck Release.375 Dia
11	710-0607	Screw, 5/16-18 x.500	39	738-04146	Screw Plug, M16 x 1.5
12	710-1260A	Screw, 5/16-18 x.75	40	754-04048	Belt, V-Type, Aramid
13	710-3168	Screw, Carriage, 3/8-16 x 1.0	41	756-04129	Pulley, Idler, 3.5"
14	710-3178	Screw, Carriage, 3/8-16 x.75	42	747-1324	Rod, Deck Adjustment
15	736-0300	Washer, Flat, .406 x.875 x.059	43	783-04399	LH Belt Cover
16	712-04065	Nut, Nylon Lock, 3/8-16	44	783-04400	RH Belt Cover
17	712-0417A	Nut, Hex, Flange, 5/8-18	45	783-04414	Deck Skirt, Center
18	712-04063	Nut, Nylon Lock, 5/16-18	46	783-04415	Deck Skirt, RH
19	712-0431	Nut, Flange Lock, 3/8-16	47	712-0206	Hex Nut, 1/2-13
20	712-3010	Nut, Hex, 5/16-18, Gr5	48	712-0229	Push Nut, 3/8
21	712-3019	Nut, 7/16-14	49	712-0641	Hex Nut, M16-1.5
22	731-04651	Mulch Plug	50	736-0225	Lock Washer, 5/8
23	714-0470	Pin, Cotter, 1/8 x 1.25	51	736-3084	Flat Washer, .51 x 1.12 x.06
24	732-0934	Extension Spring, 1.15 Dia. x 5.99 Lg.	52	732-3070	Torsion Spring, .44ID x 2.10
25	717-04074	Deck Adjustment Gear	53	783-04470	Chute Bracket
26	712-3083	Lock Nut, Hex, 1/2-13, Nylon	54	711-1762	Hinge Pin
27	732-0306A	Spring, Compression, .531 x 1.75	55	731-3131A	Chute Deflector
28	732-0459B	Spring, Extension, .94 x 6.74		631-04070	Chute Assembly (Includes Ref.# 52-55)

IMPORTANT: For a proper working machine, use Factory Approved Parts. **V-belts** are designed to engage and disengage safely. A substitute (non OEM) V-belt can be dangerous by not disengaging completely.

MANUFACTURER'S LIMITED WARRANTY FOR:



The limited warranty set forth below is given by MTD LLC with respect to new merchandise purchased and used in the United States, its possessions and territories.

"MTD" warrants this product against defects in material and workmanship for a period of two (2) years commencing on the date of original purchase and will, at its option, repair or replace, free of charge, any part found to be defective in materials or workmanship. This limited warranty shall only apply if this product has been operated and maintained in accordance with the Operator's Manual furnished with the product, and has not been subject to misuse, abuse, commercial use, neglect, accident, improper maintenance, alteration, vandalism, theft, fire, water, or damage because of other peril or natural disaster. Damage resulting from the installation or use of any part, accessory or attachment not approved by MTD for use with the product(s) covered by this manual will void your warranty as to any resulting damage.

Normal wear parts are warranted to be free from defects in material and workmanship for a period of thirty (30) days from the date of purchase. Normal wear parts include, but are not limited to items such as: batteries, belts, blades, blade adapters, grass bags, rider deck wheels, seats, snow thrower skid shoes, shave plates, auger spiral rubber and tires.

HOW TO OBTAIN SERVICE: Warranty service is available, WITH PROOF OF PURCHASE, through your local authorized service dealer. To locate the dealer in your area, check your Yellow Pages, or contact MTD LLC at P.O. Box 361131, Cleveland, Ohio 44136-0019, or call 1-800-800-7310 or log on to our Web site at www.mtdproducts.com.

This limited warranty does not provide coverage in the following cases:

- a. The engine or component parts thereof. These items may carry a separate manufacturer's warranty. Refer to applicable manufacturer's warranty for terms and conditions.
- b. Log splitter pumps, valves, and cylinders have a separate one year warranty.
- c. Routine maintenance items such as lubricants, filters, blade sharpening, tune-ups, brake adjustments, clutch adjustments, deck adjustments, and normal deterioration of the exterior finish due to use or exposure.
- d. Service completed by someone other than an authorized service dealer.

- e. MTD does not extend any warranty for products sold or exported outside of the United States, its possessions and territories, except those sold through MTD's authorized channels of export distribution.
- f. Replacement parts that are not genuine MTD parts.
- g. Transportation charges and service calls.

No implied warranty, including any implied warranty of merchantability of fitness for a particular purpose, applies after the applicable period of express written warranty above as to the parts as identified. No other express warranty, whether written or oral, except as mentioned above, given by any person or entity, including a dealer or retailer, with respect to any product, shall bind MTD. During the period of the warranty, the exclusive remedy is repair or replacement of the product as set forth above.

The provisions as set forth in this warranty provide the sole and exclusive remedy arising from the sale. MTD shall not be liable for incidental or consequential loss or damage including, without limitation, expenses incurred for substitute or replacement lawn care services or for rental expenses to temporarily replace a warranted product.

Some states do not allow the exclusion or limitation of incidental or consequential damages, or limitations on how long an implied warranty lasts, so the above exclusions or limitations may not apply to you.

In no event shall recovery of any kind be greater than the amount of the purchase price of the product sold. **Alteration of safety features of the product shall void this warranty.** You assume the risk and liability for loss, damage, or injury to you and your property and/or to others and their property arising out of the misuse or inability to use the product.

This limited warranty shall not extend to anyone other than the original purchaser or to the person for whom it was purchased as a gift.

HOW STATE LAW RELATES TO THIS WARRANTY: This limited warranty gives you specific legal rights, and you may also have other rights which vary from state to state.

IMPORTANT: Owner must present Original Proof of Purchase to obtain warranty coverage.

MTD LLC, P.O. BOX 361131 CLEVELAND, OHIO 44136-0019; Phone: 1-800-800-7310