

ITEM# 1-1-32103

E
EASTPOINT

Bethwilder

*8 ft / 2.44m BILLIARD TABLE
with DARTBOARD and CUE RACK*

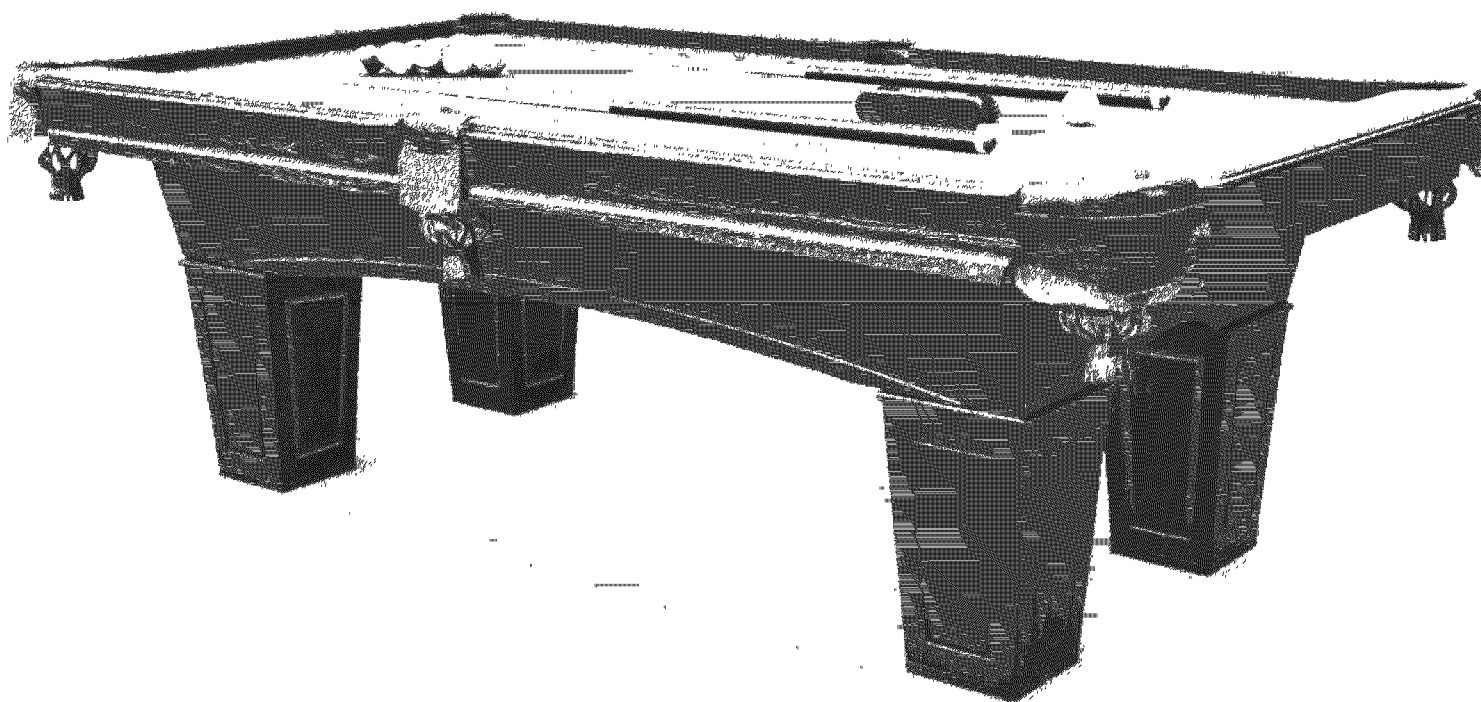

Assembly Instructions
Model # 32103

www.eastpointsports.com

TWO OR MORE ADULTS REQUIRED FOR ASSEMBLY



EASTPOINT

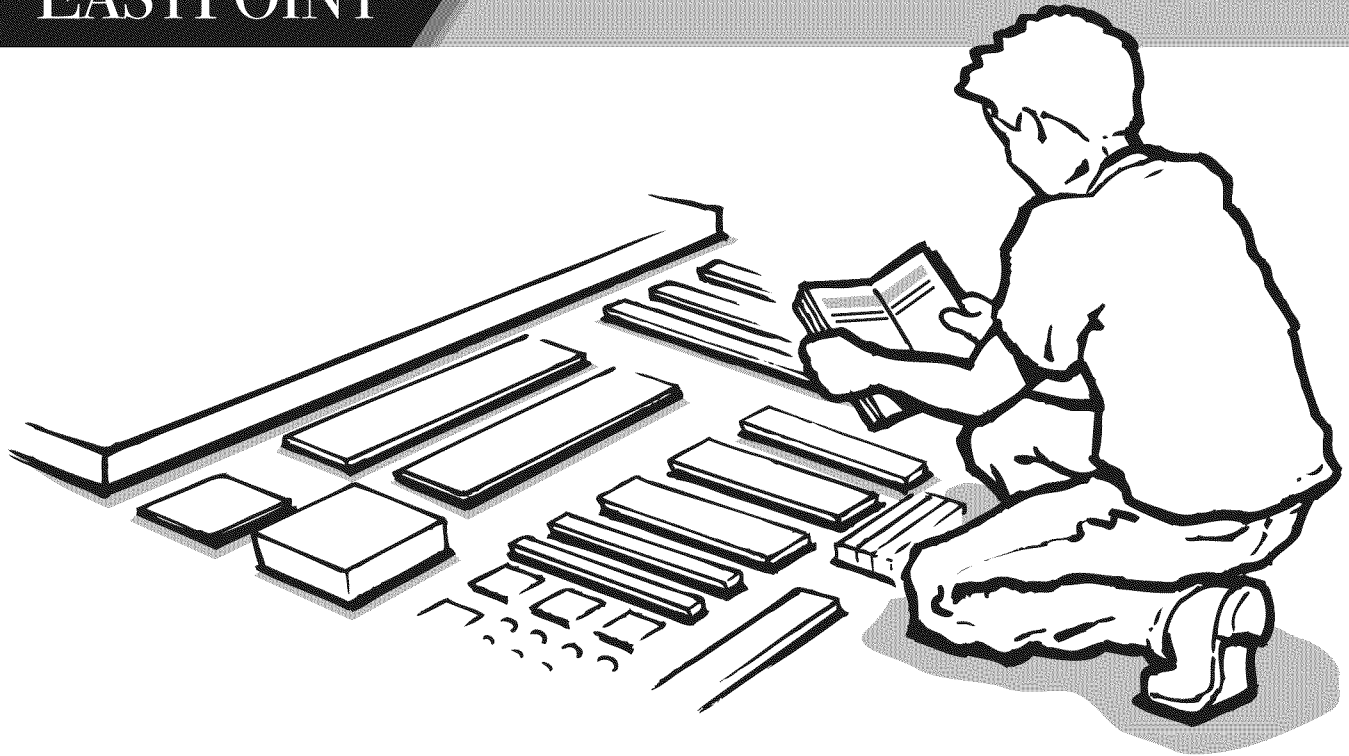

IMPORTANT - Lay out all parts before you begin

- Please review the parts identifier and make sure that you have all parts before beginning assembly.
- If any questions or issues, please contact us at 1-973-585-4747 **BEFORE** returning the product to the original place of purchase.
- Please keep your original sales receipt. Staple it on the adjacent page in the space provided for future reference/use. It will be required to receive service help or parts under warranty.

CONTACT INFO

Hours

Monday to Friday
(9:00am to 5pm EST)

Technical Support or Replacement Parts

Email us at: consumerservice@eastpointports.com
Visit us at: www.eastpointports.com
Call: 973-585-4747

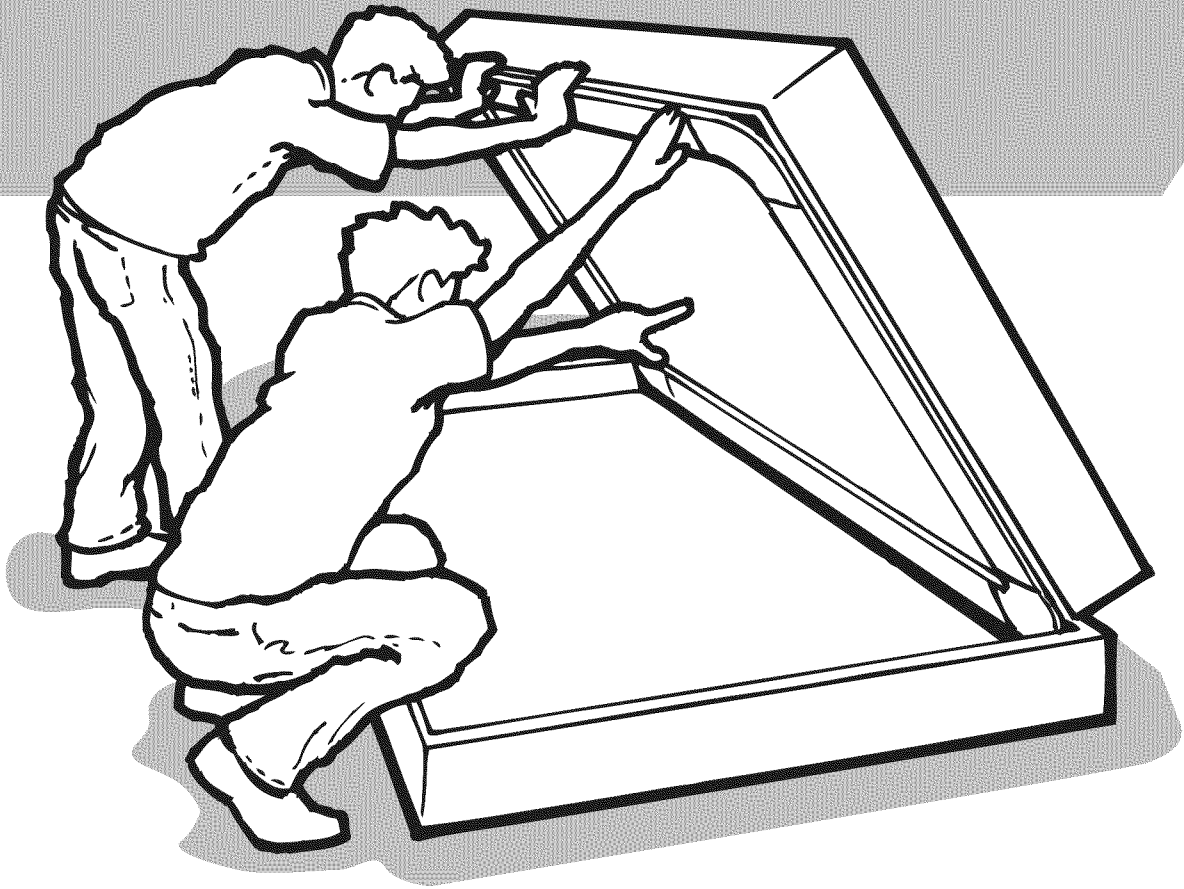

BEFORE BUILDING - Please inspect your playfield

Your Cabinet (Billiard table Playfield) is **NOT replaceable**. Any damage that exists to your playfield is not reparable under warranty. If your playfield is damaged, the entire game must be returned to the original place of purchase for an exchange.

**Please attach
RECEIPT HERE**

It will be required to receive service help or parts under warranty.

TOOLS

Required

- 1 - Phillips Head Screwdriver
(Standard Size) – Not Included
- 1 - Flat Head Screwdriver
(Standard Size) – Not Included
- 1 – Wrench – Included

Recommended (Not Required):

- Electric Screwdriver or Power Driver
CAUTION – DO NOT OVER TIGHTEN. Over Tightening will result in irreparable damage to the product. If using, please make sure that the tool is set to a very low torque to prevent damage to the product.
- Socket Wrench Set

How to use the: PARTS IDENTIFIER

Before you begin assembly, please make sure that you have all the parts listed and in the correct quantities. This will ensure the quickest and most organized assembly.

Be sure to work on the assembly on a soft non-marring surface such as carpet or the inside of the corrugate box top to prevent causing damage to the table surface during assembly.

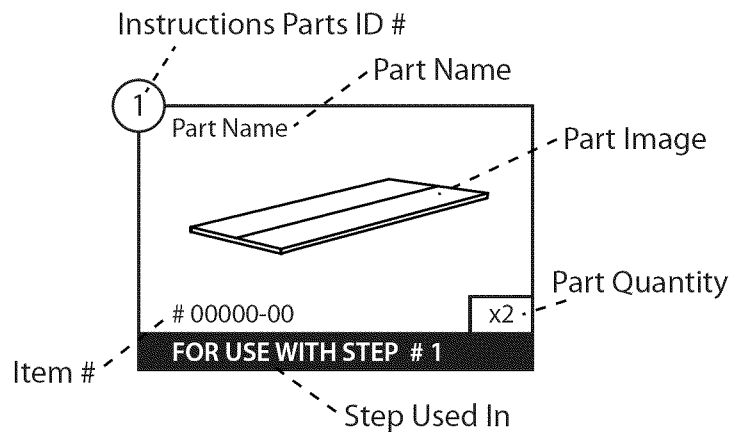

PARTS IDENTIFIER

Components

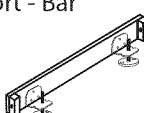
1 Support - Bar

 # 32103-01ES x1
STEP # 5

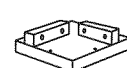
2 Leg Panel - Groove

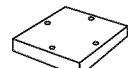
 # 32103-02ES x16
STEP # 1

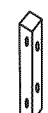
3 Leg Top

 # 32103-03ES x4
STEP # 2

4 Leg Base

 # 32103-04ES x4
STEP # 2

5 Corner Brace

 # 32103-05ES x4
STEP # 3

6 Side Cabinet

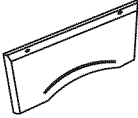
 # 32103-06ES x2
STEP # 3

Components cont.

7 End Cabinet



32103-07ES x2

STEP # 3

8 Main Cabinet

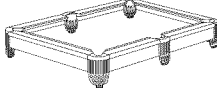

32103-08ES x1

STEP # 5

9 Shim - 1mm



32101-11ES x3

STEP # 8

10 Shim - 2mm



32101-12ES x3

STEP # 8

11 Shim - 3mm



32101-13ES x3

STEP # 8

12 Pocket Side (Pre-Installed)



32103-12ES x2

PRE-INSTALLED

13 Pocket Corner (Pre-Installed)



32103-13ES x4

PRE-INSTALLED

Hardware

60 6.5 x 35mm Allen Key Bolt

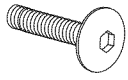

32103-60ES x32

STEP # 1

61 Allen Key



37003-62ES x1

STEP # 1,5

62 4 x 44.5mm Screws



37003-60ES x32

STEP # 2

63 8 x 38mm Bolt

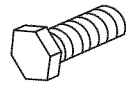

32101-65ES x44

STEP # 3, 4 and 7

64 8 x 19mm Washer

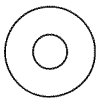

32101-61ES x56

STEP # 3,4, and 7

65 Wrench



32101-69ES x1

STEP # 3, 4, 7, and 9

66 Nut - Hex - 8mm



32101-66ES x12

STEP # 7

67 6.5 x 50mm Allen Key Bolt

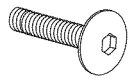

32103-67ES x2

STEP #5

68 "L" Bracket - Steel
(Pre-assembled on Part#1)

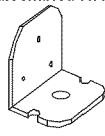

32101-68ES x2

STEP #5

69 Surface Leveler
(Pre-assembled on Part#68)



32103-69ES x2

STEP #5

70 4 x 18mm Screws



32103-70ES x4

STEP #5

Accessories

Chalk



37003-27ES x2

Triangle

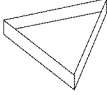

32103-31ES x1

Brush

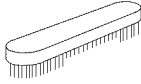

32103-32ES x1

Billiard Balls

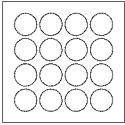

37003-26ES 1 Set

Cues



32101-32ES x2

BILLIARD TABLE - INSTRUCTIONS

BEFORE

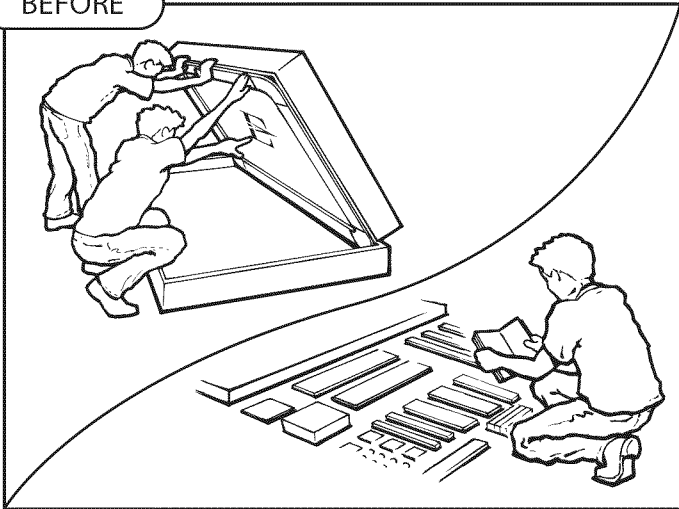

NOTE:

BEFORE BUILDING - Please inspect your playfield and layout all your parts

Your Cabinet (Billiard Table playfield) is NOT replaceable. Any damage that exists to your playfield is not repairable under warranty. If your playfield is damaged, the entire game must be returned to the original place of purchase for an exchange.

STEP 1

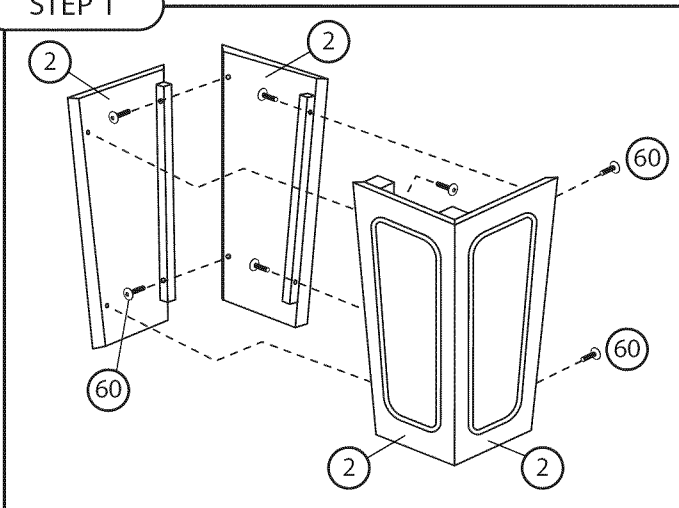

COMPONENTS

QTY.

(2) Leg Panel - Groove x16

HARDWARE

QTY.

(60) 6.5x35mm Allen Key Bolt x32

(61) Allen Key x1

NOTE:

Repeat for all 4 legs.

STEP 2

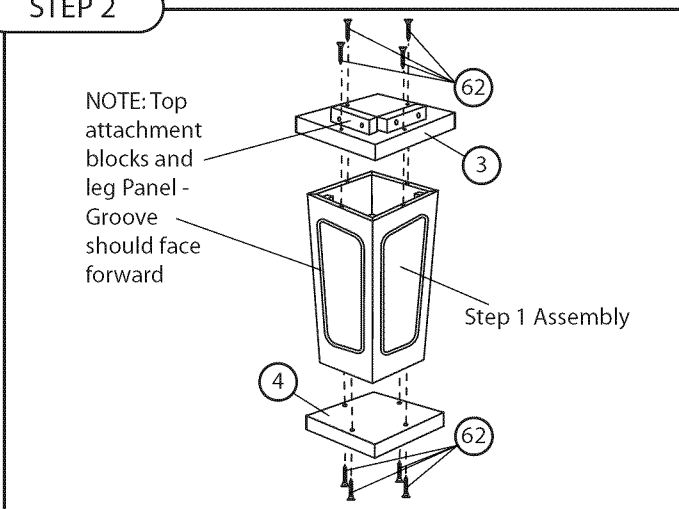

COMPONENTS

QTY.

(3) Leg Top x4

(4) Leg Base x4

Step 1 Assembly x1

HARDWARE

QTY.

(62) 4x44.5mm Screws x32

NOTES

NOTE: Top attachment blocks and leg Panel - Groove should face forward

Repeat for all 4 legs.

STEP 3

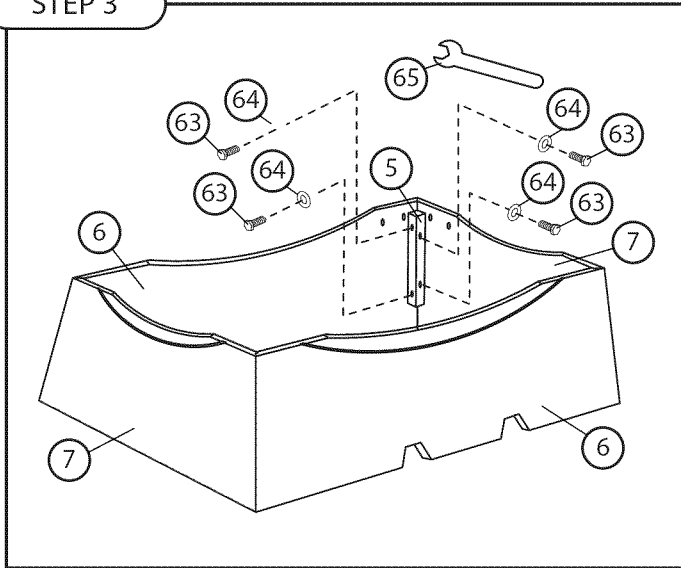

COMPONENTS	QTY.
5 Corner Brace	x4
6 Side Cabinet	x2
7 End Cabinet	x2

HARDWARE	QTY.
63 8x38mm Bolt (use 16 of 32)	x16
64 8x19mm Washer (use 16 of 56)	x16
65 Wrench	x1

NOTE:
Repeat for all four corners.

Do not overtighten.

STEP 4

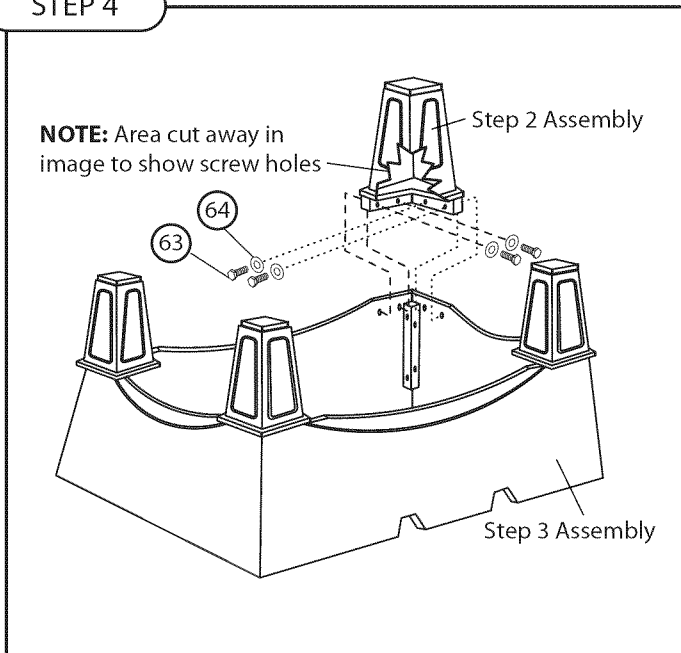

COMPONENTS	QTY.
Step 2 Assembly	x4
Step 3 Assembly	x1

HARDWARE	QTY.
63 8x38mm Bolt	x16
64 8x19mm Washer	x16
65 Wrench	x1

NOTE: Area cut away in image to show screw holes

Repeat for all four corners.

Do not overtighten.

STEP 5

STEP 5A

Assembly for support bar

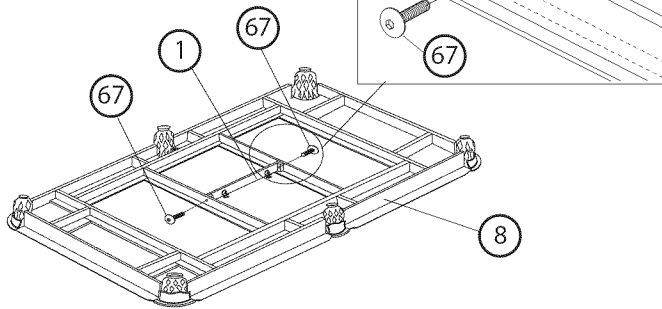

STEP 5B

Attaching surface levelers to backside of playfield .

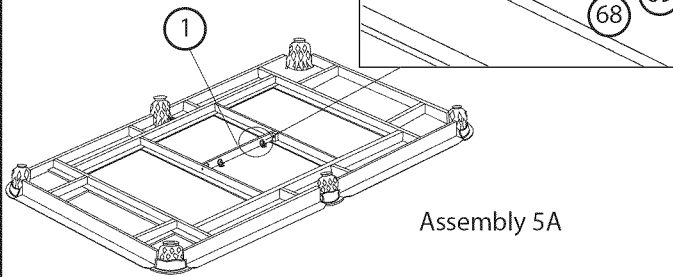

Assembly 5A

COMPONENTS	QTY.
① Support Bar	x1
⑧ Main Cabinet	x1

HARDWARE	QTY.
⑥1 Allen Key	x1
⑥7 6.5 x 50mm Allen Key Bolt	x2

NOTES
Repeat for both sides of support bar .

COMPONENTS	QTY.
Assembly 5A	x1

HARDWARE	QTY.
⑥8 "L" Bracket - Steel (Pre-assembled on Part#1)	x2
⑥9 Surface Leveler (Pre-assembled on Part#68)	x2
⑦0 4x18mm Screw s	x4

NOTES
Repeat for both surface levelers .

STEP 6

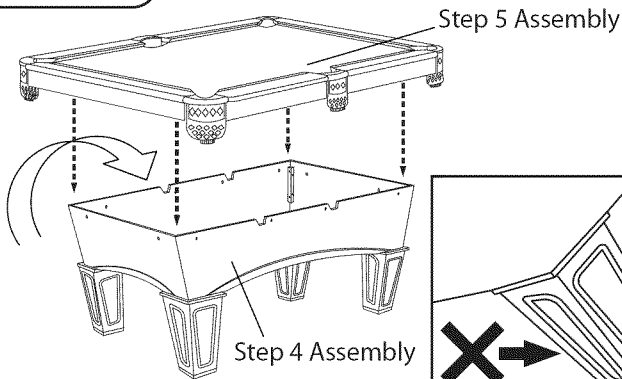

NOTE: Using two adults pick up and flip step 4 / 5 assemblies.

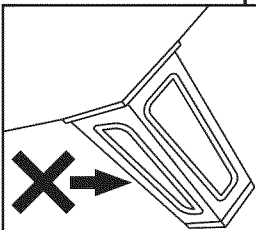

NOTE: Avoid sideways pressure to legs when flipping over

COMPONENTS	QTY.
Step 4 Assembly	x1
Step 5 Assembly	x1

NOTES
NOTE: Using two adults pick up and flip step 4 / 5 assemblies.
Then carefully position the main cabinet into position.
NOTE: Avoid sideways pressure to legs.

STEP 7

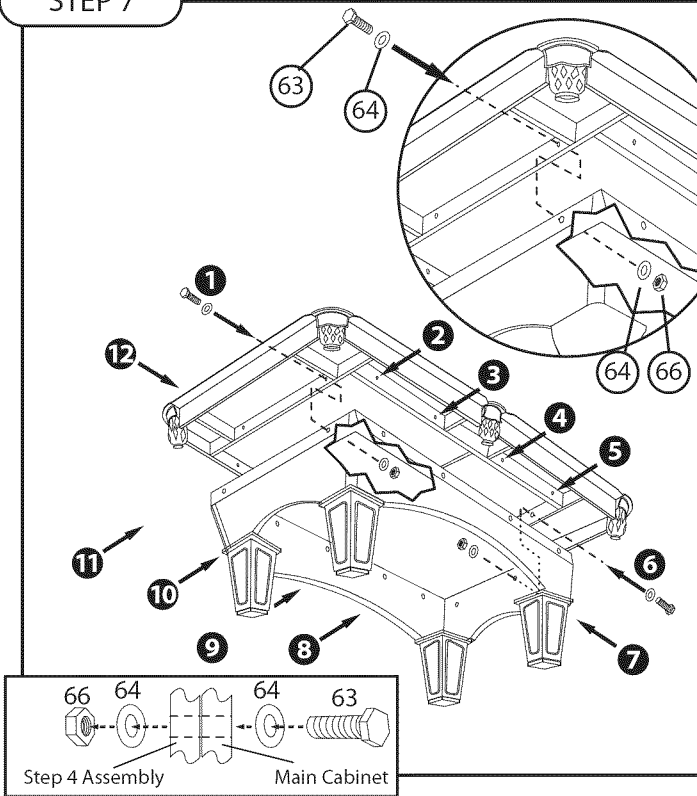

COMPONENTS	QTY.
Step 6 Assembly	x1
HARDWARE	QTY.
63 8x38mm Bolt	x12
64 8x19mm Washer (use 16 of 56)	x24
65 Wrench	x1
66 Nut - Hex - 8mm	x12

NOTE:

STEP 8

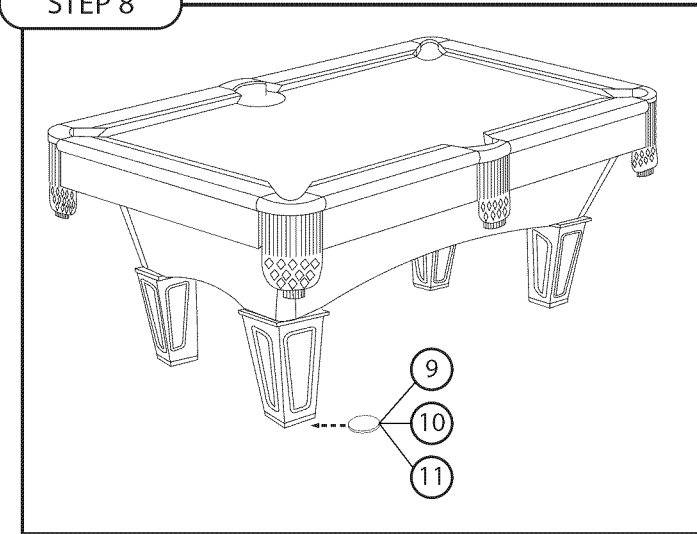

COMPONENTS	QTY.
9 1mm Shim	x3
10 2mm Shim	x3
11 3mm Shim	x3
Step 7 Assembly	x1

NOTE:
Use The Shims as needed under legs to level the table.

You will need a level to do this.

STEP 9

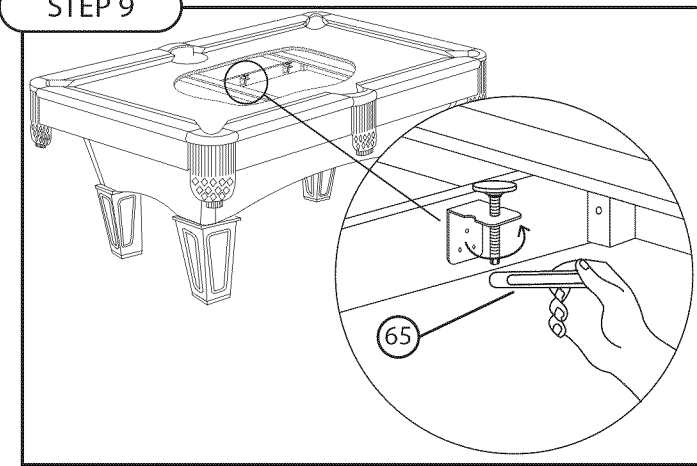

COMPONENTS	QTY.
Step 8 Assembly	x1
HARDWARE	QTY.
65 Wrench	x1

NOTE:
If your playfield is not perfectly level after using your shims, adjust your surface levelers using the wrench supplied to move the playfield up and down.

Limited Warranty

As described in and as limited by this Limited Warranty, EastPoint Sports, Ltd. (the "Company") warrants this Billiard Table, Dartboard and Cue Rack (the "Product") to be free from defects in workmanship and materials for a period of 90 days from the date of original purchase. The term defects shall mean any imperfections that impair the use of the product. The Company reserves the right to request confirmation of Proof of Purchase when requesting parts or service in order to confirm that the game is within its warranty period.

What is Covered: Except as provided herein, this Limited Warranty covers all defects in materials and workmanship. This Limited Warranty is void if the Product is:

- Damaged through improper usage or storage, negligence, misuse, abuse, transportation damage, acts of nature, or accident (including failure to follow the instructions supplied with the product)
- Used in commercial applications, rentals or a commercial environment
- Modified or repaired by anyone not authorized by the Company

What is Not Covered:

The Limited Warranty does not cover:

- Expendable items such as cosmetic parts, game playing accessories, and any other items that may show signs of wear due to normal usage
- Any transportation/delivery/installation costs incurred by the Consumer (either home from the original place of purchase or back to the original place of purchase)

What the Company Will Pay For:

- If any part or component of the Product which is covered by this Limited Warranty is found by the Company to be defective, the Company will provide replacement parts without charge. The Company's obligation to repair or replace the Product or any portion thereof, shall be limited to the original purchase price of the product.
- If during the Limited Warranty period, the product is found to be defective, the Company will, at the Company's option, send parts, or make remuneration for the Product (either the same or equivalent value) without charge.

How to Obtain Warranty Service: In order to enforce your rights under this Limited Warranty, you must follow these procedures:

- You must return the ORIGINAL COPY OF YOUR SALES RECEIPT to the Company.
- You must call the Company's Consumer Service Department at 1-877-279-7071 on Monday through Friday between the hours of 9:00 A.M. and 5:00 P.M. (EST) to notify the Company of the nature of the problem. At the Company's option, replacement parts or a new Product (either the same or equivalent value) will be sent to you at no charge.
- If you are instructed to return the Product to the Company for servicing, you are responsible for shipping the Product, at your expense, to the address designated by the Company in packaging that will protect against further damage.
- You must also include your name, address, daytime telephone number, Product model number, and a description of the problem.
- The Company will pay for any shipping charges to return the repaired or replaced Product to you.

THIS LIMITED WARRANTY IS AVAILABLE ONLY TO THE ORIGINAL PURCHASER OF THE PRODUCT AND IS VALID ONLY IN THE UNITED STATES. THE COMPANY'S LIABILITY IS LIMITED TO THE REPAIR, REPLACEMENT, OR REMUNERATION, AT ITS OPTION, OF ANY DEFECTIVE PRODUCT AND SHALL NOT INCLUDE ANY LIABILITY FOR INDIRECT, INCIDENTAL, OR CONSEQUENTIAL DAMAGES OF ANY KIND. THIS WARRANTY IS EXPRESSLY MADE IN LIEU OF ALL OTHER WARRANTIES, EXPRESSED OR IMPLIED, INCLUDING BUT NOT LIMITED TO THE IMPLIED WARRANTY OF MERCHANTABILITY AND THE IMPLIED WARRANTY OF FITNESS FOR A PARTICULAR PURPOSE. SOME STATES DO NOT ALLOW LIMITATIONS ON HOW LONG AN IMPLIED WARRANTY LASTS OR DO NOT ALLOW FOR EXCLUSION OF INCIDENTAL OR CONSEQUENTIAL DAMAGES. TO THAT EXTENT, THE ABOVE LIMITATIONS MAY NOT APPLY TO YOU.

This Limited Warranty gives you specific legal rights, but you may also have other rights that vary from state to state.

If you have any questions regarding this Limited Warranty or the operation of the Product, you may call or write us.

ALL WARRANTY CLAIMS MUST BE ACCOMPANIED BY A COPY OF THE SALES RECEIPT/PROOF OF PURCHASE. REPORT ANY DEFECTS TO:



628 ROUTE 10, SUITE #5 WHIPPANY, NEW JERSEY 07981 • 1-973-585-4747

TABLE MAINTENANCE AND CARE

Table Top –

- It is OK to gently vacuum the felt side of the billiard table with any standard handheld vacuum brush attachment.



www.eastpointsports.com