

# Operator's Manual

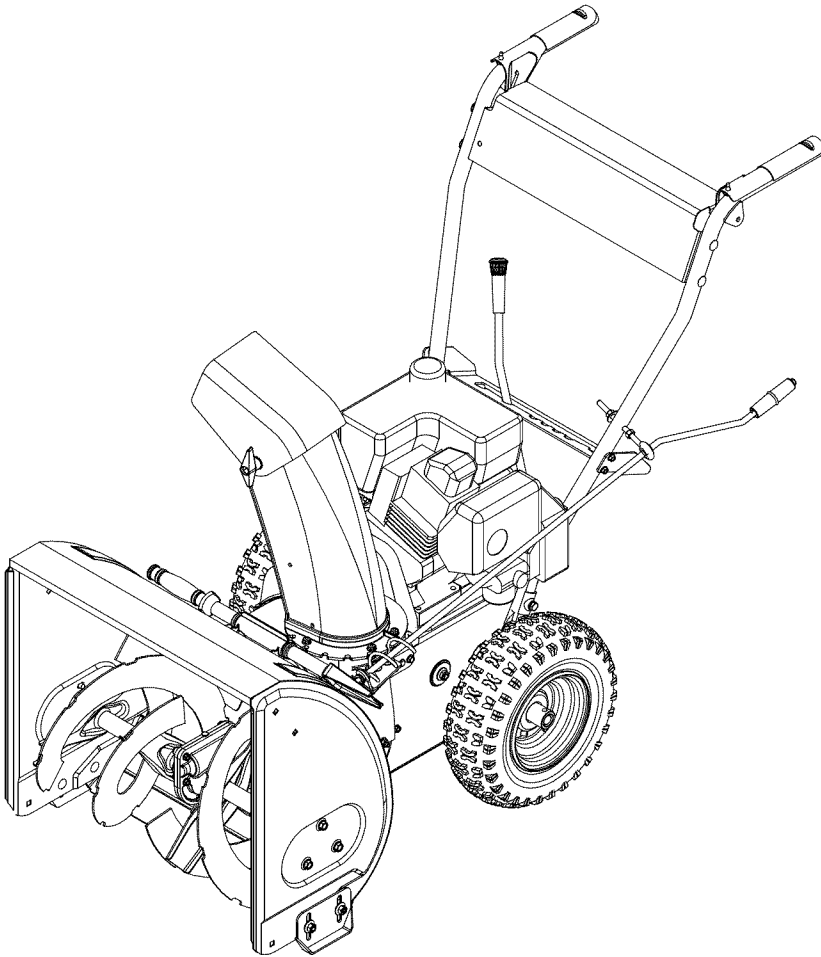

## Snow Thrower

Model Series 611

**IMPORTANT:** Read safety rules and instructions carefully.

**Warning:** This unit is equipped with an internal combustion engine and should not be used on or near any unimproved forest-covered, brush-covered or grass-covered land unless the engine's exhaust system is equipped with a spark arrester meeting applicable local or state laws (if any). If a spark arrester is used, it should be maintained in effective working order by the operator. In the State of California the above is required by law (Section 4442 of the California Public Resources Code). Other states may have similar laws. Federal laws apply on federal lands. A spark arrester for the muffler is available through your nearest engine authorized service dealer or contact the service department, P.O. Box 361131 Cleveland, Ohio 44136-0019.

**MTD LLC, P.O. BOX 361131 CLEVELAND, OHIO 44136-0019**

PRINTED IN U.S.A.

FORM NO. 770-10001C  
(7/2003)

## TABLE OF CONTENTS

<b>Content</b>	<b>Page</b>
Important Safe Operation Practices.....	3
Hardware Pack.....	5
Assembling Your Snow Thrower .....	6
Know Your Snow Thrower .....	10
Operating Your Snow Thrower .....	11
Making Adjustments .....	14
Maintaining Your Snow Thrower.....	16
Service .....	17
Troubleshooting.....	20
Parts List.....	21

## FINDING MODEL NUMBER

This Operator's Manual is an important part of your new Snow Thrower. It will help you assemble, prepare and maintain the unit for best performance. Please read and understand what it says.



**Before you start assembling your new equipment**, please locate the model plate on the equipment and copy the information from it in the space provided below. The information on the model plate is very important if you need help from our Customer Support Department or an authorized dealer.

- You can locate the model number by standing behind the unit in the operating position and looking down at the rear frame below the engine. A sample model plate is explained below. For future reference, please copy the model number and the serial number of the equipment in the space below.

\_\_\_\_\_

(Model Number)

\_\_\_\_\_

(Serial Number)

**MTD LLC**  
**P. O. BOX 361131**  
**CLEVELAND, OH 44136**  
**330-220-4683**  
**800-800-7310**

www.mtdproducts.com

**Copy the model number here:** \_\_\_\_\_

**Copy the serial number here:** \_\_\_\_\_

## ENGINE INFORMATION

The engine manufacturer is responsible for all engine-related issues with regards to performance, power-rating, specifications, warranty and service. Please refer to the engine manufacturer's Owner's/Operator's Manual packed separately with your unit for more information.

## CALLING CUSTOMER SUPPORT

Please do NOT return the unit to the retailer from which it was purchased, without first contacting Customer Support. Should you have difficulty assembling this product or have any questions regarding the controls, operation or maintenance of this unit, please call the Customer Support Department.



Call **1- (330) 220-4MTD (4683)** or **1- (800)-800-7310** to reach a Customer Support representative. Please have your unit's model number and serial number ready when you call. See previous section to locate this information. You will be asked to enter the serial number in order to process your call.

For more details about your machine, visit our web site at [www.mtdproducts.com](http://www.mtdproducts.com)

---

## SECTION 1: IMPORTANT SAFE OPERATION PRACTICES



This symbol points out important safety instructions, which if not followed, could endanger the personal safety and/or property of yourself and others. Read and follow all instructions in this manual before attempting to operate this machine. Failure to comply with these instructions may result in personal injury. When you see this symbol—**heed its warning**.



**WARNING:** Engine Exhaust, some of its constituents, and certain vehicle components contain or emit chemicals known to the State of California to cause cancer, birth defects or other reproductive harm.



**DANGER:** This machine was built to be operated according to the rules for safe operation in this manual. As with any type of power equipment, carelessness or error on the part of the operator can result in serious injury. This machine is capable of amputating hands and feet and throwing objects. Failure to observe the following safety instructions could result in serious injury or death.

### Training

1. Read, understand, and follow all instructions on the machine and in the manual(s) before attempting to assemble and operate. Keep this manual in a safe place for future and regular reference and for ordering replacement parts.
2. Be familiar with all controls and their proper operation. Know how to stop the machine and disengage them quickly.
3. Never allow children under 14 years old to operate this machine. Children 14 years old and over should read and understand the operation instructions and safety rules in this manual and should be trained and supervised by a parent.
4. Never allow adults to operate this machine without proper instruction.
5. Thrown objects can cause serious personal injury. Plan your snow-throwing pattern to avoid discharge of material toward roads, bystanders and the like.
6. Keep bystanders, helpers, pets and children at least 75 feet from the machine while it is in operation. Stop machine if anyone enters the area.
7. Exercise caution to avoid slipping or falling, especially when operating in reverse.
6. Disengage all clutch levers before starting the engine.
7. Never attempt to make any adjustments while engine is running, except where specifically recommended in the operator's manual.
8. Let engine and machine adjust to outdoor temperature before starting to clear snow.
9. To avoid personal injury or property damage use extreme care in handling gasoline. Gasoline is extremely flammable and the vapors are explosive. Serious personal injury can occur when gasoline is spilled on yourself or your clothes, which can ignite. Wash your skin and change clothes immediately.
  - a. Use only an approved gasoline container.
  - b. Extinguish all cigarettes, cigars, pipes and other sources of ignition.
  - c. Never fuel machine indoors.
  - d. Never remove gas cap or add fuel while the engine is hot or running.
  - e. Allow engine to cool at least two minutes before refueling.
  - f. Never over fill fuel tank. Fill tank to no more than ½ inch below bottom of filler neck to provide space for fuel expansion.
  - g. Replace gasoline cap and tighten securely.
  - h. If gasoline is spilled, wipe it off the engine and equipment. Move machine to another area. Wait 5 minutes before starting the engine.
  - i. Never store the machine or fuel container inside where there is an open flame, spark or pilot light (e.g. furnace, water heater, space heater, clothes dryer etc.).
  - j. Allow machine to cool at least 5 minutes before storing.

### Preparation

1. Thoroughly inspect the area where the equipment is to be used. Remove all doormats, newspapers, sleds, boards, wires and other foreign objects, which could be tripped over or thrown by the auger/impeller.
2. Always wear safety glasses or eye shields during operation and while performing an adjustment or repair to protect your eyes. Thrown objects which ricochet can cause serious injury to the eyes.
3. Do not operate without wearing adequate winter outer garments. Do not wear jewelry, long scarves or other loose clothing, which could become entangled in moving parts. Wear footwear which will improve footing on slippery surfaces.
4. Use a grounded three-wire extension cord and receptacle for all units with electric start engines.
5. Adjust collector housing height to clear gravel or crushed rock surfaces.

### Operation

1. Do not put hands or feet near rotating parts, in the auger/impeller housing or discharge chute. Contact with the rotating parts can amputate hands and feet.
2. The auger/impeller clutch lever is a safety device. Never bypass its operation. Doing so makes the machine unsafe and may cause personal injury.
3. The clutch levers must operate easily in both directions and automatically return to the disengaged position when released.

4. Never operate with a missing or damaged discharge chute. Keep all safety devices in place and working.
5. Never run an engine indoors or in a poorly ventilated area. Engine exhaust contains carbon monoxide, an odorless and deadly gas.
6. Do not operate machine while under the influence of alcohol or drugs.
7. Muffler and engine become hot and can cause a burn. Do not touch.
8. Exercise extreme caution when operating on or crossing gravel surfaces. Stay alert for hidden hazards or traffic.
9. Exercise caution when changing direction and while operating on slopes.
10. Plan your snow-throwing pattern to avoid discharge towards windows, walls, cars etc. Thus, avoiding possible property damage or personal injury caused by a ricochet.
11. Never direct discharge at children, bystanders and pets or allow anyone in front of the machine.
12. Do not overload machine capacity by attempting to clear snow at too fast of a rate.
13. Never operate this machine without good visibility or light. Always be sure of your footing and keep a firm hold on the handles. Walk, never run.
14. Disengage power to the auger/impeller when transporting or not in use.
15. Never operate machine at high transport speeds on slippery surfaces. Look down and behind and use care when in reverse.
16. If the machine should start to vibrate abnormally, stop the engine, disconnect the spark plug wire and ground it against the engine. Inspect thoroughly for damage. Repair any damage before starting and operating.
17. Disengage all clutch levers and stop engine before you leave the operating position (behind the handles). Wait until the auger/impeller comes to a complete stop before unlogging the discharge chute, making any adjustments, or inspections.
18. Never put your hand in the discharge or collector openings. Always use the clean-out tool provided to unclog the discharge opening. Do not unclog discharge chute while engine is running. Shut off engine and remain behind handles until all moving parts have stopped before unlogging.
19. Use only attachments and accessories approved by the manufacturer (e.g. wheel weights, tire chains, cabs etc.).
20. If situations occur which are not covered in this manual,

use care and good judgment. Contact your dealer or telephone 1-800-800-7310 for assistance and the name of your nearest servicing dealer.

## Maintenance & Storage

1. Never tamper with safety devices. Check their proper operation regularly. Refer to the maintenance and adjustment sections of this manual.
2. Before cleaning, repairing, or inspecting machine disengage all clutch levers and stop engine. Wait until the auger/impeller come to a complete stop. Disconnect the spark plug wire and ground against the engine to prevent unintended starting.
3. Check bolts and screws for proper tightness at frequent intervals to keep the machine in safe working condition. Also, visually inspect machine for any damage.
4. Do not change the engine governor setting or over-speed the engine. The governor controls the maximum safe operating speed of the engine.
5. Snow thrower shave plates and skid shoes are subject to wear and damage. For your safety protection, frequently check all components and replace with original equipment manufacturer's (OEM) parts only. "Use of parts which do not meet the original equipment specifications may lead to improper performance and compromise safety!"
6. Check clutch controls periodically to verify they engage and disengage properly and adjust, if necessary. Refer to the adjustment section in this operator's manual for instructions.
7. Maintain or replace safety and instruction labels, as necessary.
8. Observe proper disposal laws and regulations for gas, oil, etc. to protect the environment.
9. Prior to storing, run machine a few minutes to clear snow from machine and prevent freeze up of auger/impeller.
10. Never store the machine or fuel container inside where there is an open flame, spark or pilot light such as a water heater, furnace, clothes dryer etc.
11. Always refer to the operator's manual for proper instructions on off-season storage.





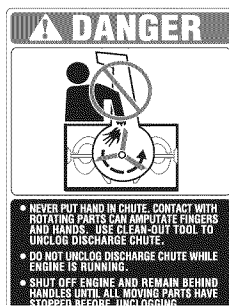





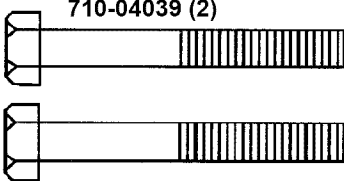
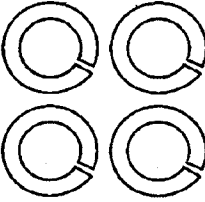
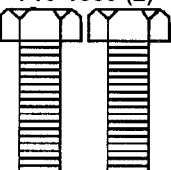
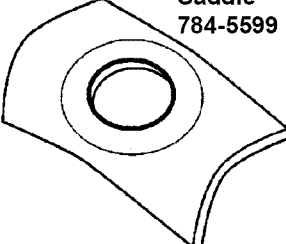

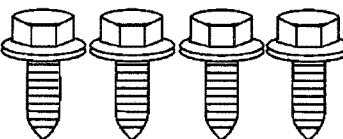
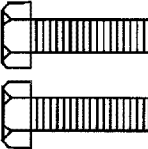

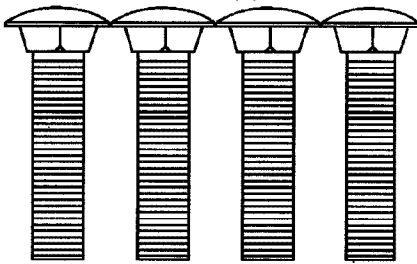
**WARNING:** Restrict the use of this power machine to persons who read, understand and follow the warnings and instructions in this manual and on the machine.

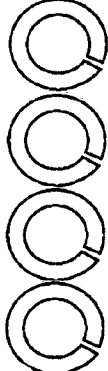

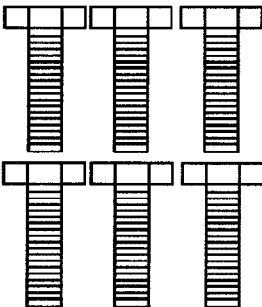
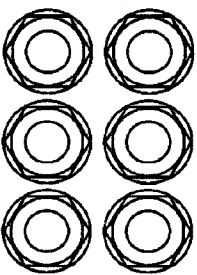
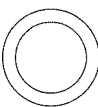
## SECTION 2: CONTENTS OF HARDWARE PACK (Boxed Unit)

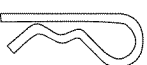
Lay out the hardware according to the illustration below for identification purposes. Part numbers are shown in parentheses. (Hardware pack may contain extra items which are not used on your unit.)

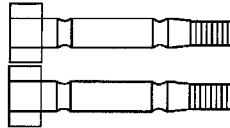
<p><b>A ATTACHING THE HANDLES</b></p> <p>Hex Bolts 710-04039 (2)</p>  <p>Lock Washers 736-0119 (4)</p>  <p>Hex Bolts 710-1880 (2)</p>  <p>Saddle 784-5599 (2)</p> 	<p><b>B ATTACHING CLUTCH GRIPS</b></p> <p>Hex Lock Nut 712-0429 (2)</p>  <p>Spacer 750-1032 (2)</p> <p>(No Picture)</p> <p>Hex Cap Screw 710-3103 (2)</p> <p>(No Picture)</p>
<p><b>D ATTACHING SPEED SELECTOR PLATE AND SHIFT LEVER</b></p> <p>Self-Tapping Screws 710-0599 (4)</p>  <p>Hex Bolts 710-3015 (2)</p>  <p>Hex Lock Nuts 712-3027 (2)</p> 	<p><b>C ATTACHING HANDLE PANEL</b></p> <p>Carriage Bolts 710-0262 (4)</p>  <p>Hex Patch Nuts 712-3068 (4)</p>  <p>Lock Washers 736-0119 (4)</p> 
<p><b>E "Z" FITTING NUTS</b></p> <p>Hex Nuts 712-0121 (4)</p>  <p>"Z" Fitting not shown here</p>	<p><b>F ATTACHING CHUTE ASSEMBLY</b></p> <p>Hex Bolts 710-3015 (6)</p>  <p>Hex Lock Nuts 712-3027 (6)</p>  <p>Chute Flange Keepers 731-0851 (3) Not Shown</p>
<p><b>G ATTACHING CHUTE DIRECTIONAL CONTROL</b></p> <p>Flat Washer 736-0185</p>  <p>Cupped Washer 736-0242</p>  <p>Hex Nuts 712-3010 (2)</p>  <p>Hairpin Clip 714-0104</p> 	<p><b>H REPLACEMENT SHEAR BOLTS</b></p> <p>Hex Lock Nuts 712-0429 (2)</p>  <p>Hex Bolts 710-0890A (2) See note below.</p> 

**NOTE:** These are replacement shear bolts and nuts. Store in a safe place until needed.

## SECTION 3: ASSEMBLING YOUR SNOW THROWER

**NOTE:** References to right or left side of the snow thrower are determined from behind the unit in the operating position. The “operator’s position” is defined as standing directly behind the snow thrower, facing the handle panel.

**NOTE:** This Operator’s Manual covers several models. **Snow thrower features vary by model.** Not all features discussed in this manual are applicable to all snow thrower models.

### Unpacking

#### Crate

- Remove screws from the top sides and ends of the shipping crate.
- Set panel aside to avoid tire punctures or personal injury.
- Remove and discard plastic bag that covers unit.
- Remove any loose parts included with unit (i.e., Operator’s Manual, etc.).
- Roll unit out of crate.

#### Box

- Remove staples or break glue on top flaps of the carton. Remove any loose parts included with unit (i.e., operator’s manual, etc.).
- Cut corners of the carton and lay ends down flat. Remove packing material.
- Roll unit out of carton. Check carton thoroughly for loose parts before discarding.

### Loose Parts (Crated Unit)

The augers are secured to the auger shaft with two shear bolts and hex lock nuts. If you hit a foreign object or ice jam, the snow thrower is designed so that the bolts may shear. Two replacement shear bolts and nuts are provided for your convenience. Store in a safe place until needed. See Figure 1.

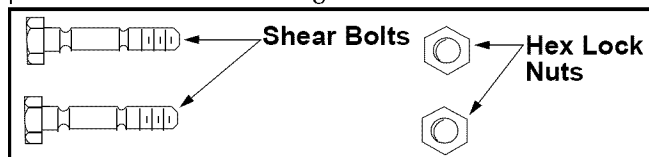

Figure 1

### Loose Parts (Boxed Unit)

Listed below are the parts of the snow thrower packed loose with units that come unassembled in a box. You will need these parts along with hardware from the hardware pack, illustrated on the previous page, to assemble the equipment. Identify the loose parts before proceeding to assemble. See Figure 2.

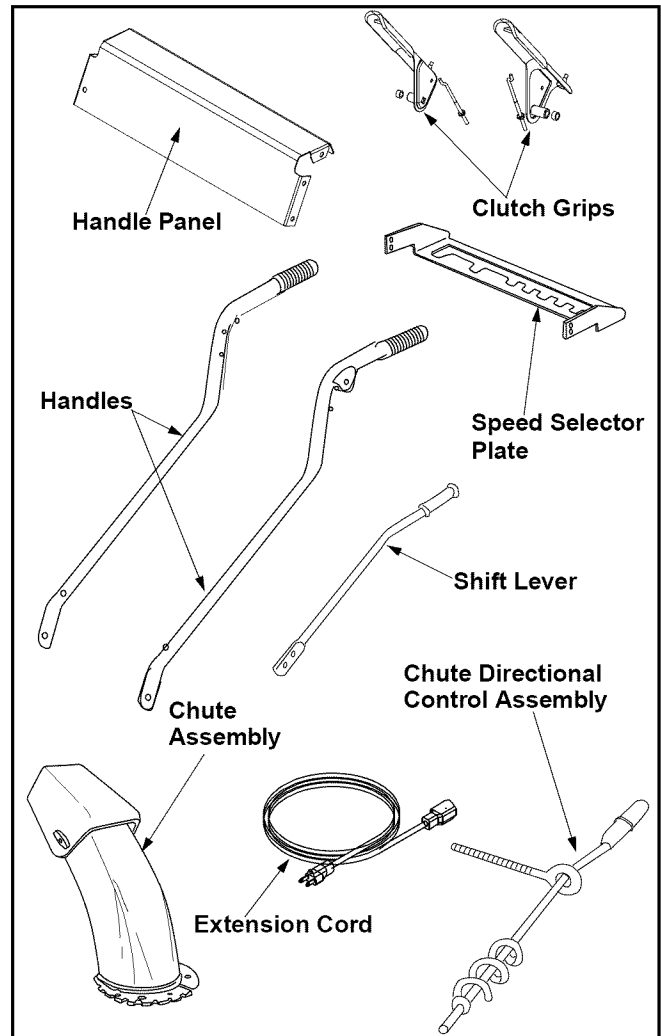

Figure 2

1. Right and Left Handles
2. Handle Panel
3. Speed Selector Plate
4. Chute Assembly
5. Chute Directional Control Assembly
6. Shift Lever
7. Clutch Grips
8. Hardware Pack
9. Extension Cord (If Equipped)

**NOTE:** Follow the Assembly instructions below per the packaging of your unit. So if your unit came in a box, proceed to page 7, Assembly (Boxed Unit).

### Assembly (Crated Unit)



**WARNING:** Disconnect the spark plug wire and ground it against the engine to prevent unintended starting.

- Remove the **lower** two plastic wing knobs, cupped washers and carriage bolt (eyebolt on the left side) from the lower handle. See Figure 3.

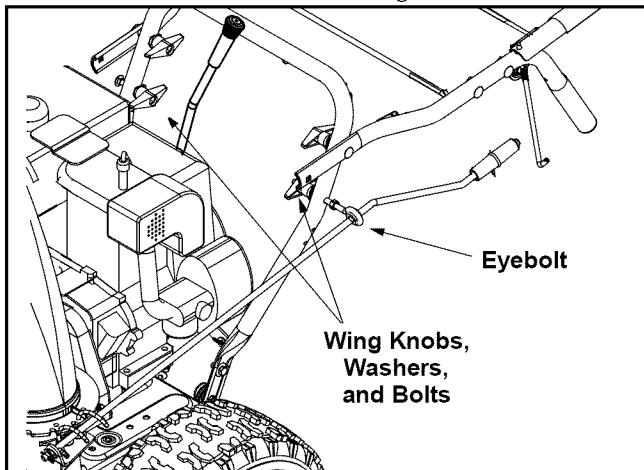

Figure 3

- Raise the upper handle assembly until it locks over the lower handle. See Figure 4.
- Observe the lower rear area of the snow thrower to be sure both cables are aligned with roller guides.
- Secure the upper handle and lower handle with the two plastic wing knobs, cupped washers and carriage bolt (eyebolt on the left side) previously removed. See Figure 4.

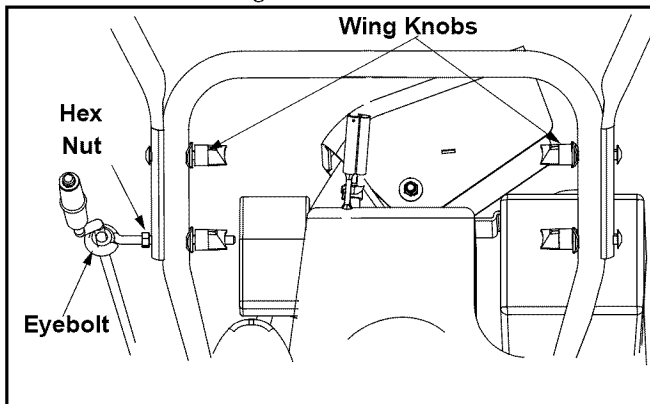

Figure 4

- Adjust the eyebolt on the chute directional control so the rod does not come into contact with the engine by moving the hex nut against the handle (if necessary). Retighten the wing nut to secure the directional control in this position. See Figure 4.
- Thread the jam nuts all the way up each of the "Z" fittings, toward the handle panel. See Figure 9.
- Make certain all cables are in the grooves of the cable roller guides located in the lower rear of the unit, one on each side. See Figure 5.
- Thread the coupling end of the cable onto the threaded portion of the "Z" fitting until the rubber bumper (located on the underside of the clutch lever) only lightly contacts the upper handle. Refer to Figure 9.

**IMPORTANT:** The cable should have very little slack, but should NOT be tight. An overtightened cable may prohibit the auger and drive from disengaging.



**WARNING:** Over-tightening the cable may prohibit the auger and drive from disengaging and compromise the safety of the snow thrower. Do NOT overtighten the cable.

- Once properly adjusted, tighten the jam nut against the coupling end of the cable to lock it in position. Refer to **Auger Control Test** on page 12 prior to operating your snow thrower. Read and follow all instructions carefully and perform all adjustments to verify your snow thrower is operating safely and properly.

## Assembly (Boxed Unit)



**WARNING:** Disconnect the spark plug wire and ground it against the engine to prevent unintended starting.

## Attaching Handles (Hardware Group A)

- Place right handle in position against the snow thrower so that the flat side of the handle is against the frame. Align the bottom hole on the handle to the corresponding hole on the snow thrower housing.
- Insert hex bolt and lock washer through these holes to secure the handle to the snow thrower housing. Do not tighten at this time. See Figure 5.

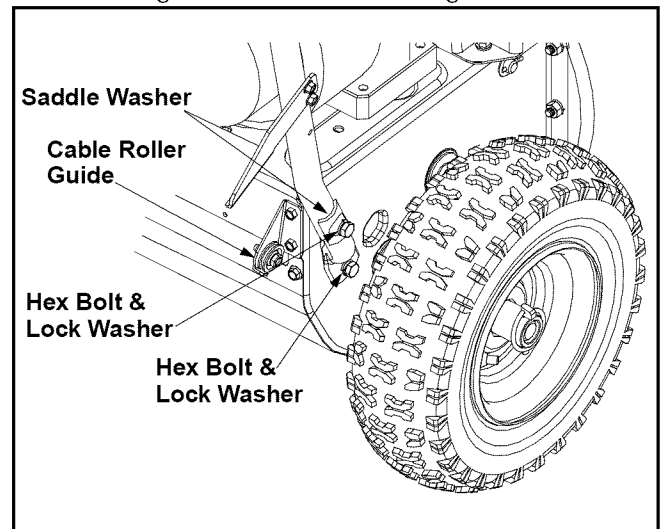

Figure 5

- Attach the left handle in the same manner and do not tighten.
- Place saddle washer over upper holes on handles and secure to the frame with lock washers and hex bolts. Do not tighten now. See Figure 5.

## Attaching Clutch Grips (Hardware Group B)

- Slide spacer on each end of the clutch grip and place the clutch grip in position on the each respective handle. Clutch grips must sit on top of the handles. See Figure 6.

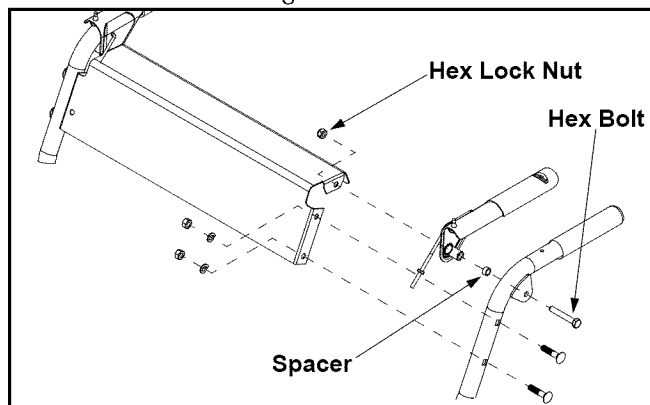

Figure 6

- Secure each clutch grip with a hex bolt threaded from the outside of each handle and tighten with hex lock nut under handle panel. See Figure 6.

## Attaching Handle Panel (Hardware Group C)

- Position the handle panel between handles and insert two carriage bolts on each side and secure with lock washers and hex patch nuts. See Figure 7.

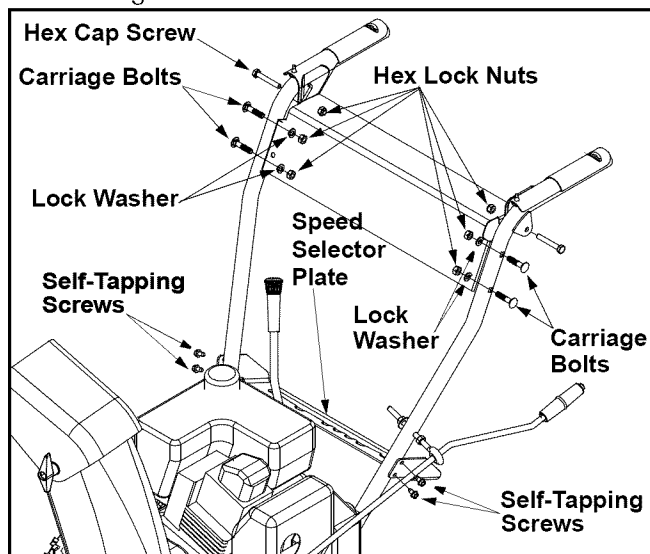

Figure 7

## Attaching Speed Selector Plate And Shift Lever (Hardware Group D)

- Assemble the speed selector plate to the **outside** of the handles. Secure using two self-tapping screws on each side. See Figure 8.
- Insert the shift lever through slot in the speed selector plate. See Figure 8.

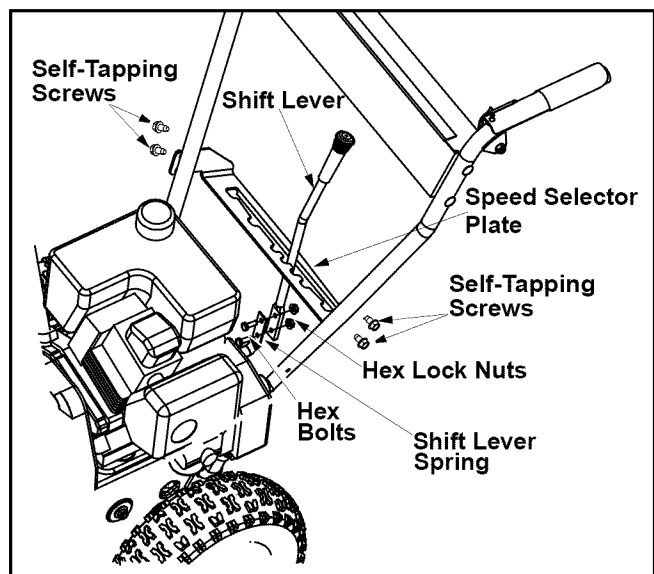

Figure 8

**NOTE:** The bend in the lever should be towards the operator.

- Secure shift lever to the shift lever spring using two hex bolts and hex lock nuts. Tighten both bolts finger tight. At this point the shift lever and shift lever spring are not against each other. As you tighten the bolts and nuts with two wrenches, these will pull together.
- Tighten all hardware assembled to this point. Make sure that clutch grips are moving freely.

## Attaching Control Cables (Hardware Group E)

- Take a "Z" fitting from the hardware pack and insert the Z end into the hole on the left clutch grip on the handle panel. See Figure 9. Thread a hex nut from hardware pack on to the Z fitting.

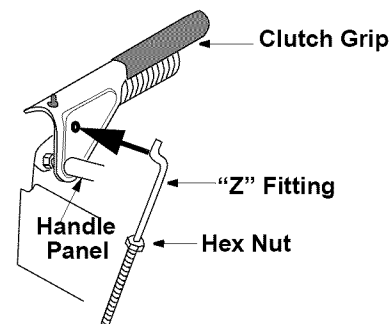

Figure 9

- Route the left cable between engine and speed selector plate and then between handle panel and clutch lever pivot rod. Make sure the cable is routed correctly in the cable roller guides located at the lower rear of the unit.
- Thread cable onto the left "Z" fitting.
- Assemble the right "Z" fitting on the right clutch grip and attach the right cable in the same manner. Both



cables should have minimal slack, but not tight.  
Tighten or loosen hex nuts on “Z” fittings to adjust.

**IMPORTANT:** If the right lock-out cable is not adjusted, the wheels will tend to turn. If the left lock-out cable is not adjusted, the augers will keep on rotating.

**NOTE:** The drive clutch cable is routed over the axle.



**WARNING:** Do not over-tighten the clutch cables. Tension on either cable in the disengaged (up) position may override the safety features of the machine.

**NOTE:** Two extra jam nuts are included in the hardware pack (Group E) in the event either are lost during shipping.

## Attaching Chute Assembly (Hardware Group F)

- Place chute assembly over chute opening, with the opening in the chute assembly facing the front of the unit.
- Place chute flange keepers beneath lip of chute assembly, with the flat side of chute flange keeper facing downward. See Figure 10.
- Insert hex bolt up through chute flange keeper and chute assembly and secure with hex lock nut. After assembling all three chute flange keepers, tighten all nuts and bolts securely. Do not over-tighten.

**NOTE:** Lock nuts cannot be threaded onto a bolt by hand. Tighten with two 7/16” or adjustable wrenches.

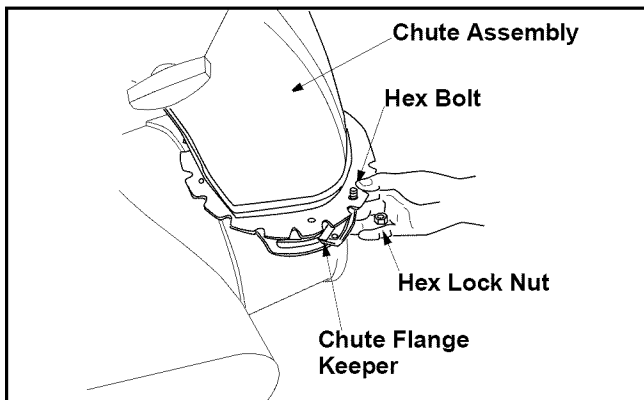

Figure 10

## Attaching Chute Directional Control (Hardware Group G)

- Loosen the two hex nuts which secure the lower chute directional control support bracket to the snow thrower housing. See Figure 11.
- Insert the end of the chute directional control into the hole in the plastic bushing on the chute bracket.
- Place the flat washer on the end of the chute directional control, and secure with hairpin clip. See Figure 11.

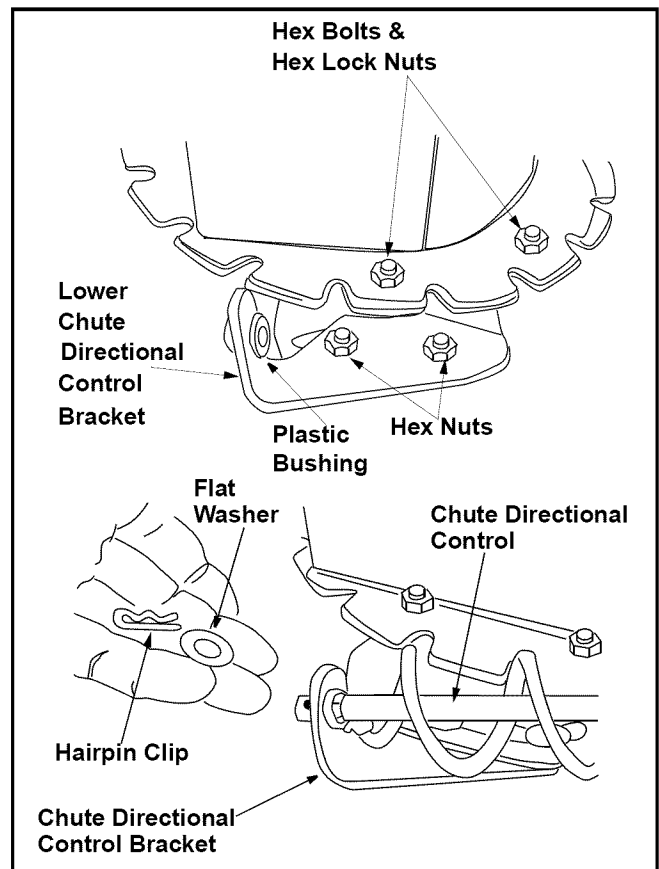

Figure 11

- Thread one hex nut onto the eyebolt on the chute directional control assembly until there is at least two inches of threads showing between the nut and the eyebolt head. See Figure 12.

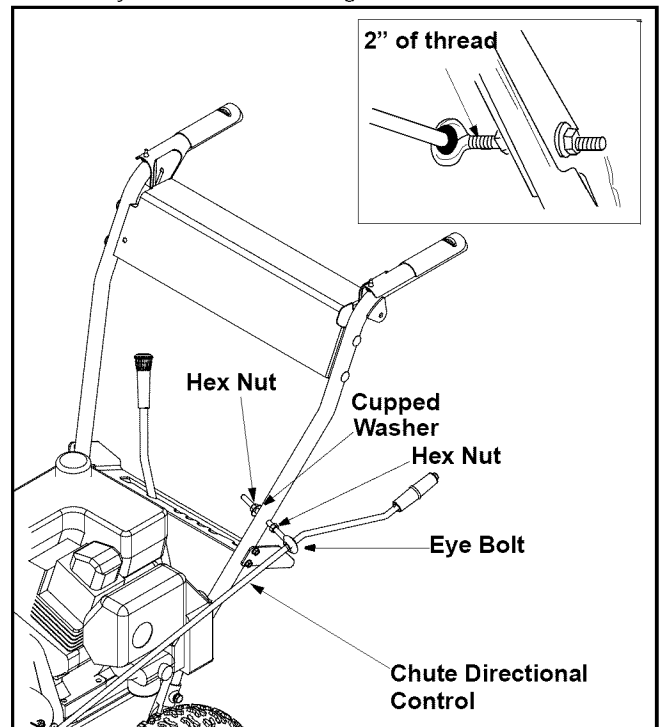

Figure 12

- Place the eyebolt into the hole located half way up the left handle and secure with cupped washer and hex nut making sure that the cupped side of the washer is against the handle.
- Adjust the chute directional control bracket so that the spiral on the chute directional control fully engages the teeth on the chute assembly. Tighten all hardware. See Figure 13.
- Check to make sure all nuts and bolts on the control panel and all four bolts which secure the handles to the frame are tight.

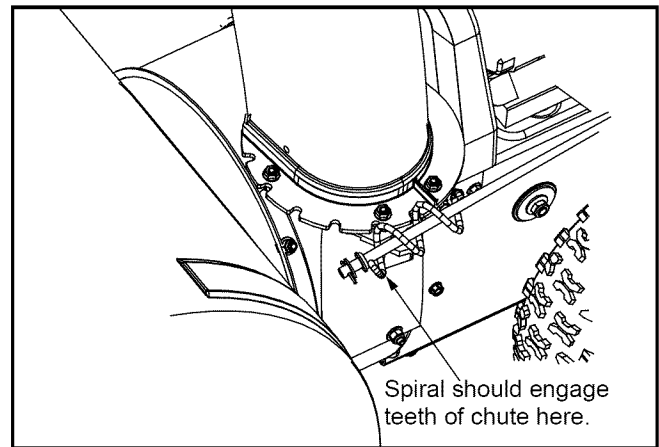

Figure 13

## SECTION 4: KNOW YOUR SNOW THROWER



**WARNING:** Read, understand, and follow all instructions and warnings on the machine and in this manual before operating.

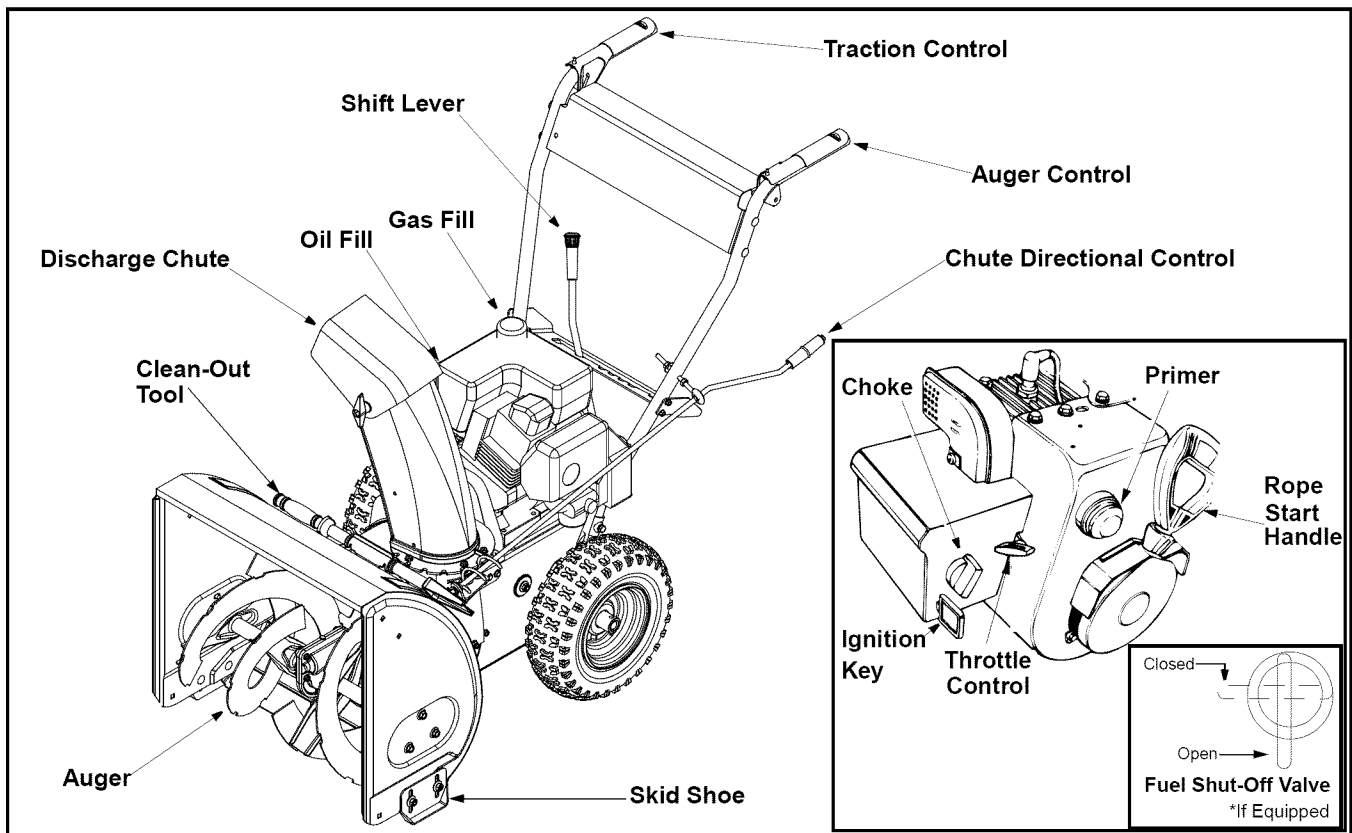

Figure 14

### Shift Lever

The shift lever is located below the handle panel and it is used to determine both ground speed and direction of

travel. It can be moved into one of seven positions.

**Forward:** There are five forward speeds; position one (1) is the slowest and position five (5) is the fastest.

**Reverse:** There are two reverse (R) speeds; R1 is the

slower of the two.

### Auger Drive Control

The auger drive control is located on the left handle. Squeeze the control grip to engage the augers. Release to stop the snow throwing action. See Figure 14.

### Traction Control

The traction control is located on the right handle. Squeeze the traction control grip to engage the wheel drive. Release to stop. See Figure 14.

### Chute Directional Control

The chute directional control is located on left side of the snow thrower. See Figure 14.

To change the direction in which snow is thrown, turn chute directional control as follows:

- Crank clockwise to discharge to the left.
- Crank counterclockwise to discharge to the right.

### Skid Shoe

The position of the skid shoe is determined by the condition of the ground from where snow has to be removed. See Figure 14.

### Throttle Control

The throttle control is located on the engine. It regulates the speed of the engine and will shut off the engine

when pushed down completely. See Figure 14.

### Safety Ignition Key

The safety ignition key must be fully inserted in the switch before the unit will start. Remove the ignition key when the snow thrower is not in use. See Figure 14.

**IMPORTANT:** Do NOT “turn” the ignition key in an attempt to start the engine. Doing so may cause it to break.

### Clean-Out Tool

**NOTE:** This item is fastened with a cable tie to the rear of the Auger Housing at the factory. Cut the cable tie before operating the snow thrower.



**WARNING:** Never use your hand to clear a clogged discharged chute. Shut off engine and remain behind handles until all moving parts have stopped before unclogging.

The chute clean-out tool is fastened to the top of the auger housing with a mounting clip. The tool is designed to clear a clogged discharged chute. Refer to **Operating Your Snow Thrower** section for more detailed information regarding the chute clean-out tool.

---

## SECTION 5: OPERATING YOUR SNOW THROWER

### Before Starting



**WARNING:** Read, understand, and follow all instructions and warnings on the machine and in this manual before operating.



**WARNING:** Use extreme care when handling gasoline. Gasoline is extremely flammable and the vapors are explosive. Never fuel machine indoors or while the engine is hot or running. Extinguish cigarettes, cigars, pipes and other sources of ignition.

### Gas And Oil Fill-up

**Service the engine with gasoline and oil** as instructed in the separate engine manual packed with your snow thrower. **Read instructions carefully.**

- A plastic **cup** is provided inside the fuel fill opening on the fuel tank. Remove and discard this cup before filling up the tank. Use the separate fuel tank cap to close after fill-up.

### To Start Engine

- Attach spark plug wire to spark plug. Make certain the metal loop on end of the spark plug wire (inside the boot) is fastened securely over the metal tip on the spark plug.
- Make certain the fuel shut-off valve, if so equipped, is in the OPEN (vertical) position.
- Make certain the auger and drive clutch levers are in the disengaged (released) position.

### Electric Starter (If equipped)



**WARNING:** The electric starter is equipped with a grounded three-wire power cord and plug and is designed to operate on 120 volt AC household current. It must be used with a properly grounded three-prong receptacle at all times to avoid the possibility of electric shock. Follow all instructions carefully prior to operating the electric starter.

- Determine that your house wiring is a three-wire grounded system. Ask a licensed electrician if you are not certain.

- **If your house wiring system is not a three-wire grounded system**, do not use this electric starter under any conditions.
- **If your home electrical system is grounded**, but a three-hole receptacle is not available, one should be installed by a licensed electrician before using the electric starter.
- **If you have a grounded three-prong receptacle**, proceed as follows:
  - Connect power cord to switch box on engine. Plug the other end of power cord into a three-prong 120-volt, grounded, AC receptacle.
  - Move throttle control up to FAST position. Insert ignition key into slot. Make sure it snaps into place. Do **not turn** key. Engine will **not start** unless key is inserted into ignition slot in carburetor cover.
  - Rotate choke knob to FULL choke position (cold engine start). If engine is warm, place choke in OFF position instead of FULL.
  - Push primer button two or three times for cold engine start, making sure to cover vent hole in primer button when pushing. DO NOT use primer to restart a warm engine after a short shutdown.
  - Push starter button to start engine.
  - When engine starts, release starter button and move choke gradually to OFF. If engine falters, move choke immediately to FULL and then gradually to OFF.
  - When disconnecting the power cord, always unplug from the three-prong receptacle first and then from the snow thrower.

## Recoil Starter

- Move throttle control up to FAST position. Insert ignition key into slot. Make sure it snaps into place. Do **not turn** key. Engine will **not start** unless key is inserted into ignition slot in carburetor cover.
- Rotate choke knob to FULL choke position (cold engine start). If engine is warm, place choke in OFF position instead of FULL.
- Push primer button two or three times for cold engine start. Do not use primer to restart a warm engine after a short shutdown.

**NOTE:** *Always cover vent hole in primer button when pushing. Additional priming may be necessary for first start if temperature is below 15°F.*

- Grasp starter handle and pull rope out slowly, until it pulls slightly harder. Let rope rewind slowly.
- Pull starter handle rapidly. Do not allow handle to snap back. Allow it to rewind slowly while keeping a firm hold on the starter handle.
- As engine warms up and begins to operate evenly, rotate choke knob slowly to OFF position. If engine falters, return to FULL choke, then slowly move to OFF position.

## To Stop Engine

- Run engine for a few minutes before stopping to help dry off any moisture on the engine.
- To help prevent possible freeze-up of starter, proceed as follows:

### Electric Starter (If equipped)

- Connect power cord to switch box on engine, then to 120 volt AC receptacle. With the engine running, push starter button and spin the starter for several seconds. The unusual sound made by spinning the starter will not harm engine or starter. Disconnect the power cord from receptacle first, and then from switch box.

### Recoil Starter

- With engine running, pull starter rope with a rapid, continuous full arm stroke three or four times. Pulling the starter rope will produce a loud clattering sound, which is not harmful to the engine or starter.
- To stop engine, move throttle control to “stop” or “off” position.
- Remove ignition key. Do not turn key.
- Disconnect the spark plug wire from the spark plug to prevent accidental starting while equipment is unattended.

**NOTE:** *Do not lose ignition key. Keep it in a safe place. Engine will not start without ignition key.*

- Wipe all snow and moisture from the carburetor cover in the area of the control levers. Also, move control levers back and forth several times.

## To Engage Drive

- With the engine running near top speed, move shift lever into one of the five FORWARD positions or two REVERSE positions. Select a speed appropriate for the snow conditions that exist. Use the slower speeds until you are familiar with the operation of the snow thrower.
- Squeeze the auger control grip and the augers will turn. Release it and the augers will stop.
- Squeeze traction control grip and the snow thrower will move. Release it and drive motion will stop.
- NEVER move shift lever without releasing drive clutch

## To Engage Augers

- To engage the augers and start throwing snow, squeeze the auger control grip against the left handle. Release to stop the augers.

### Auger Control Test

**IMPORTANT:** Perform the following test before operating your snow thrower for the first time and at the start of each winter season.

Check the adjustment of the auger control as follows:

- When the auger control is released and in the disengaged “up” position, the cable should have very little slack. It should NOT be tight.
- In a well-ventilated area, start the snow thrower engine as instructed earlier in this section under the heading Starting Engine. Make sure the throttle is set in the FAST position.
- While standing in the operator’s position (behind the snow thrower), engage the auger.
- Allow the auger to remain engaged for approximately ten (10) seconds before releasing the auger control. Repeat this several times.
- With the engine running in the FAST position and the auger control lever in the disengaged “up” position, walk to the front of the machine.
- Confirm that the auger has completely stopped rotating and shows NO signs of motion.

**IMPORTANT:** If the auger shows ANY signs of rotating, immediately return to the operator’s position and shut off the engine. Wait for ALL moving parts to stop before re-adjusting the auger control.

- To readjust the control cable, loosen the hex jam nut on the auger control cable “Z” fitting.
- Rotate the coupling end of the cable counterclockwise to provide more slack.
- Retighten the hex jam nut. See Figure 15.
- Repeat Auger Control Test to verify proper adjustment has been achieved.

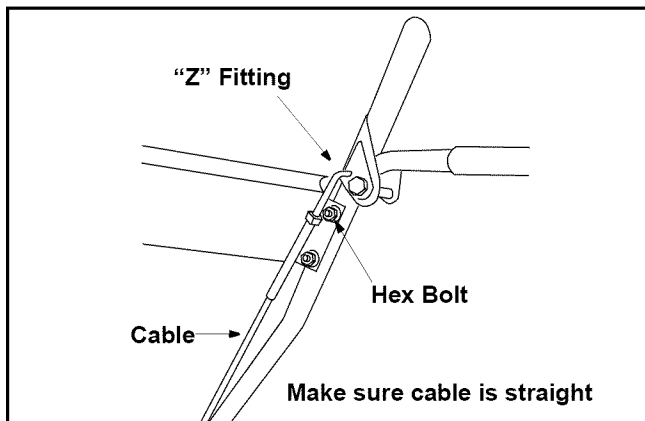

Figure 15

## Chute Clean-out Tool

The chute clean-out tool is conveniently fastened to the rear of the auger housing with a mounting clip. Should snow and ice lodge itself in the discharge chute during operation, proceed as follows to safely clean the chute and chute opening:

- Release both the Auger Control Lever and the Traction/Auger Control Lock Lever.
- Stop the engine by removing the ignition key.

- Remove the clean-out tool from the clip which secures it to the rear of the auger housing.
- Use the shovel-shaped end of the clean-out tool to dislodge and scoop any snow and ice which has formed in and near the discharge chute.



**WARNING:** Never use your hands to clean snow and ice from the discharge chute or auger housing

- Refasten the clean-out tool to the mounting clip on the rear of the auger housing, reinsert the ignition key and start the snow thrower’s engine.
- While standing in the operator’s position (behind the snow thrower), engage the auger clutch lever for a few seconds to clear any remaining snow and ice from the discharge chute.

## Drift Cutters (If equipped)

Drift cutters should be used when operating the snow thrower in heavy drift conditions.

On models so equipped, drift cutters are assembled to the auger housing inverted. Remove the carriage bolts by unthreading the hex nuts which secure them, and reinstall the drift cutters in their proper position before operating the snow thrower. See Figure 16.

If your unit is not equipped with drift cutters, contact Customer Support as instructed on page 2 for information regarding price and availability.

Snow Thrower Model Drift Cutter Kit

All models OEM-390-679

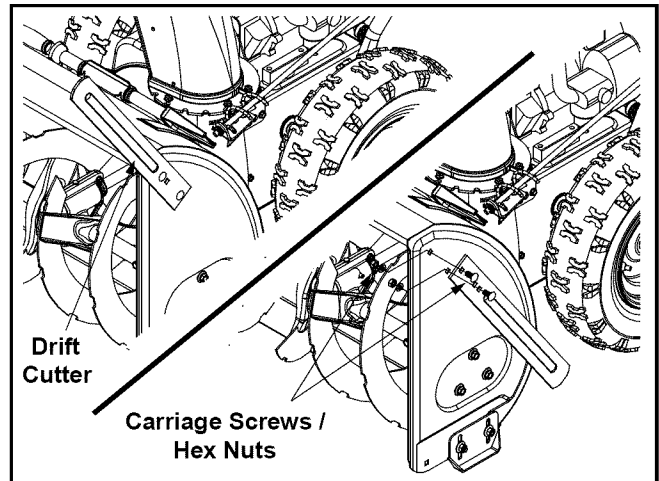

Figure 16

## Tire Chains (If equipped)

Tire chains should be used whenever extra traction is needed. If your unit is not equipped with tire chains, contact Customer Support as instructed on page 2 for information regarding price and availability.

## SECTION 6: MAKING ADJUSTMENTS



**WARNING:** Never attempt to make any adjustments while the engine is running, except where specified in operator's manual.

### Tire Pressure (Pneumatic Tires)

- The tires are overinflated for shipping purposes. Before operating check tire pressure and reduce pressure to between 15 psi and 20 psi.

**NOTE:** If the tire pressure is not equal in both tires, the unit may pull to one side or the other.

### Traction Control & Shift Lever

- To check the adjustment of the traction control clutch and shift lever, proceed as follows:
- With the engine off, move the shift lever all the way forward to fifth (5) position. With the traction control released, push the snow thrower forward. The unit should move forward freely. Then engage the traction control grip. Wheels should stop turning.
- Now release the traction control grip and push the unit again.
- Move the shift lever back to the fast reverse position, then all the way forward again. There should be no resistance in the shift lever, and the wheels should keep turning.
- If you feel resistance when moving the shift lever or the wheels stop when they should not, loosen the jam nut on the traction control cable and unthread the cable one turn.
- If the wheels do not stop when you engage the traction control grip, loosen the jam nut on the traction control cable and thread the cable in one turn.
- Recheck the adjustment and repeat as necessary. Tighten the jam nut to secure the cable when correct adjustment is reached.



**WARNING:** Drain the gasoline out of snow thrower engine, place a piece of plastic film under the gas cap to avoid spillage before beginning the job.

To test further for correct adjustment, if necessary, proceed as follows:

- Tip the snow thrower so that it rests on the auger housing. See Figure 17.
- Remove the frame cover underneath the snow thrower by removing six self-tapping screws.

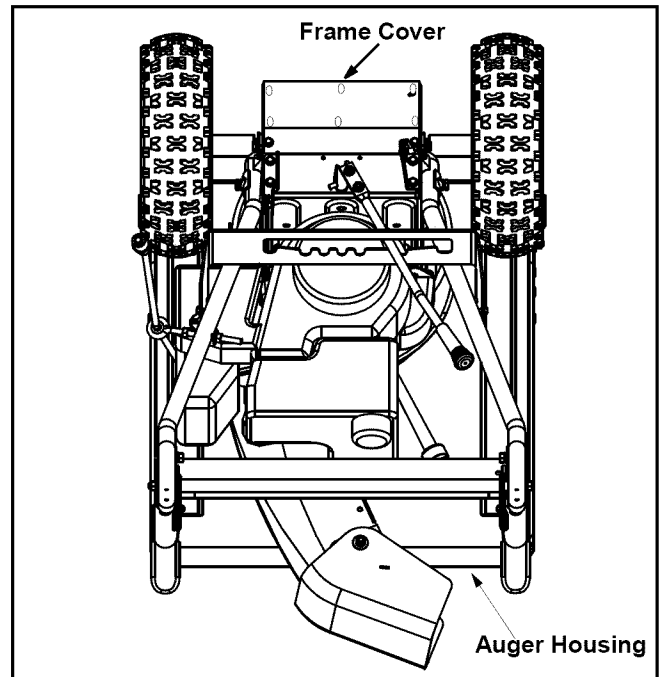

Figure 17

- With the traction control is released, there must be clearance between the friction wheel and the drive plate in all positions of the shift lever. See Figure 18.
- With the traction control is engaged, the friction wheel must contact the drive plate.

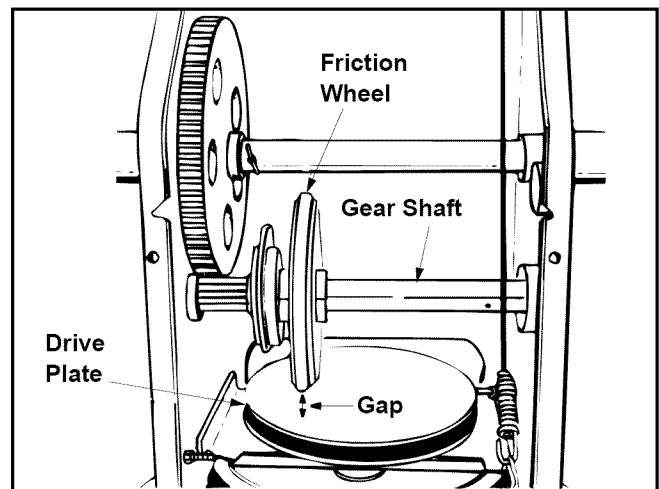

Figure 18

If adjustment is necessary.

- Loosen the jam nut on the traction control cable and thread the cable in or out as necessary.
- Retighten the jam nut to secure the cable when correct adjustment is reached.
- Reassemble the frame cover.

**NOTE:** If you placed plastic film under the gas cap, be certain to remove it before operating.

## Chute Assembly

The distance snow is thrown can be adjusted by changing the angle of the chute assembly. To do so, stop the engine by removing the ignition key and loosen the plastic wing knobs found on either side of the discharge chute. Pivot the chute upward or downward before re-tightening the wing knobs.

## Auger Control

Refer to Auger Control Test in the Operating Section to adjust the auger control.

## Skid Shoes

The space between the shave plate and the ground can be adjusted. See Figure 19.

- For close snow removal on a smooth surface, raise skid shoes higher on the auger housing.
- Use a middle or lower position when the area to be cleared is uneven.

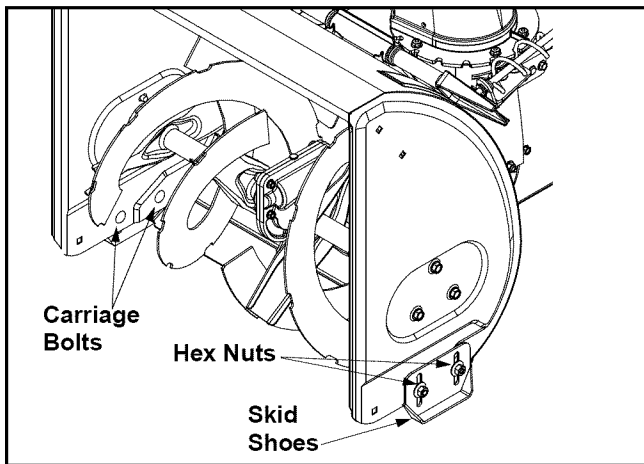

Figure 19



**WARNING:** Do not operate this snow thrower on gravel as loose gravel can be easily picked up and thrown by the auger causing injury to the operator and/or damage to the snow thrower.

- Adjust skid shoes by loosening the four hex nuts and carriage bolts. Move skid shoes to desired position.
- Make certain the entire bottom surface of skid shoe is against the ground to avoid uneven wear on the skid shoes. Retighten nuts and bolts securely.

## Carburetor

- Minor carburetor adjustment may be required to compensate for differences in fuel, temperature, altitude and load.
- Refer to the separate engine manual, packed with your unit, for carburetor adjustment information.



**WARNING:** If any adjustments need to be made to the engine while the engine is running (e.g. carburetor), keep clear of all moving parts. Be careful of muffler, engine and other surrounding heated surfaces.

## Drive Wheels

The wheels may be adjusted for two different methods of operation. The adjustment is made by placing the click pins in one of two different holes on the right side of the unit. See Figure 20.

**One Wheel Driving:** Insert the click pin only through the outside hole of the axle (NOT the rim) on the right side of the snow thrower. This position gives power drive to the left wheel only, making the unit easier to maneuver.

**Both Wheels Driving:** Insert the click pin through the hole in the hub of the rim and the INSIDE hole on the snow thrower's right axle. This position is good for heavy snow as there is power drive in both wheels.

**IMPORTANT:** NEVER operate the snow thrower with the click pin inserted through both the RIM and the OUTSIDE HOLE in the axle. Doing so can result in serious damage to the drive system.

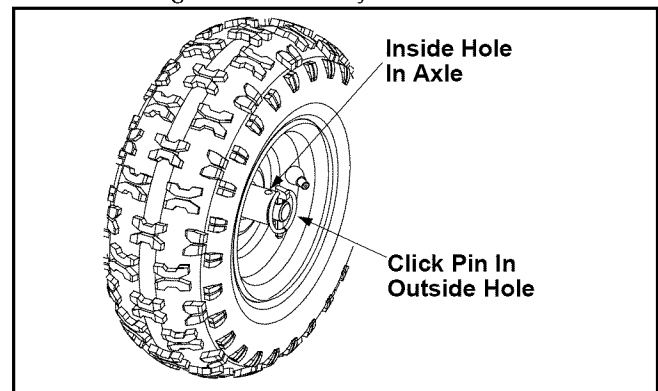

Figure 20

## SECTION 7: MAINTAINING YOUR SNOW THROWER



**WARNING:** Before lubricating, repairing, or inspecting, disengage all clutch levers and stop engine. Wait until all moving parts have come to a complete stop. Disconnect spark plug wire and ground it against the engine to prevent unintended starting.

### Lubrication

#### Engine

Refer to the separate engine manual packed with your unit for all engine lubrication instructions.



**WARNING:** When following instructions in the engine manual for draining oil, be sure to protect frame to avoid oil dripping onto transmission parts.

#### Gear Shaft

- Lubricate the gear shaft with a good all-weather multi-purpose light grease at least once a season or after every 25 hours of operation.

**IMPORTANT:** Keep all grease and oil off the friction wheel and drive plate.

#### Chute Directional Control

- The worm gear on the chute directional control should be greased with multipurpose automotive grease.

#### Wheels

- Oil or spray lubricant into bearings at least once a season. Pull the click pins and remove wheels, clean and coat axles with a multipurpose automotive grease. See Figure 21.

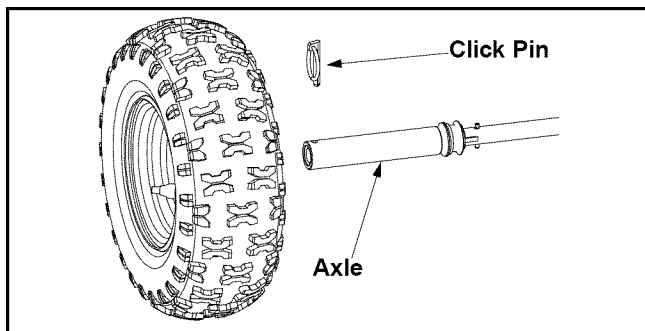

Figure 21

#### Auger Shaft

At least once a season, remove the shear bolts on the auger shaft. Spray lubricant inside the shaft. Also lubricate the plastic auger bearings at least once a season on the end of the auger shaft with a standard grease gun. See Figure 22.

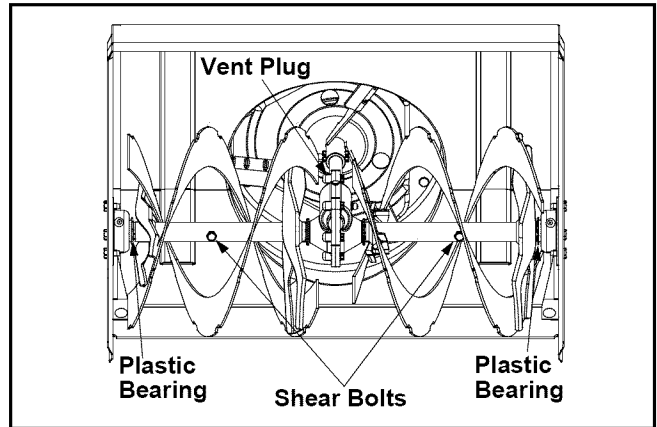

Figure 22

#### Gear Case

- The worm gear case has been filled with grease at the factory. If disassembled for any reason, lubricate with 2 ounces of shell grease, part number 737-0168.

**IMPORTANT:** Do not overfill the gear case. Damage to the seals could result. Be sure the vent plug is free of grease in order to relieve pressure.

#### Drive and Shifting Mechanism

- Remove rear cover. Oil any chains, sprockets, gears, bearings, shafts, and shifting mechanism at least once a season. Use engine oil or a spray lubricant. Avoid getting oil on rubber friction wheel and aluminum drive plate. See Figure 23.

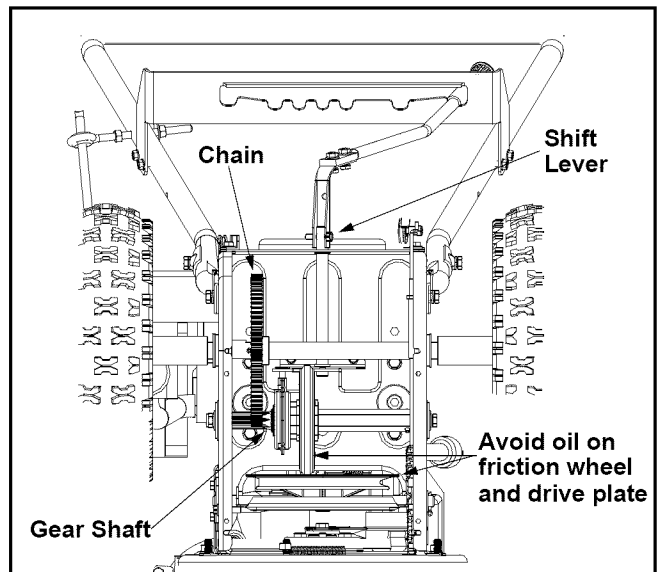

Figure 23



## SECTION 8: SERVICING YOUR SNOW THROWER



**WARNING:** Before servicing, repairing, or inspecting, disengage all clutch levers and stop engine. Wait until all moving parts have come to a complete stop. Disconnect spark plug wire and ground it against the engine to prevent unintended starting.

### Engine

Refer to the separate engine manual packed with your unit for all engine maintenance procedures.

### Augers

The augers are secured to the spiral shaft with two shear bolts and hex lock nuts. If you hit a hard foreign object or ice jam, the snow thrower is designed so that the bolts may shear. Refer to Figure 22.

- If the augers will not turn, check to see if the bolts have sheared. Replacement shear bolts and hex lock nuts have been provided with the snow thrower. When replacing bolts, spray an oil lubricant into shaft before inserting new bolts.

**IMPORTANT:** NEVER replace the auger shear bolts with standard hex bolts. Any damage to the auger gearbox or other components as a result of doing so will NOT be covered by your snow thrower's warranty.

### Shave Plate and Skid Shoes

- The shave plate and skid shoes on the bottom of the snow thrower are subject to wear. They should be checked periodically and replaced when necessary.

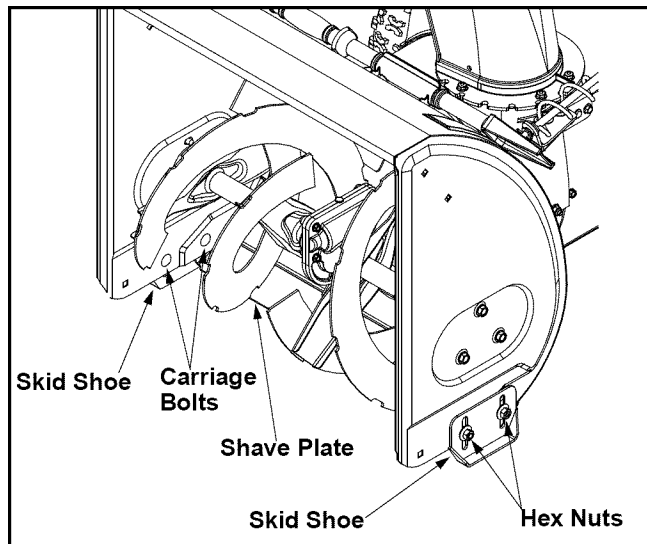

Figure 24

- To remove skid shoes, remove the four carriage bolts, cupped washers and hex nuts which attach them to the snow thrower. Reassemble new skid shoes with the four carriage bolts, cupped washers (cupped side goes against skid shoes) and hex nuts. See Figure 24.
- To remove shave plate, remove the carriage bolts, cupped washers and hex nuts which attach it to the snow thrower housing. Reassemble new shave plate, making sure heads of carriage bolts are to the inside of housing. Tighten securely.

### Belt Removal and Replacement

#### Auger Belts

- Remove plastic belt cover from front of the engine by removing the two self-tapping screws. See Figure 25.
- Drain the gasoline from the snow thrower, or place a piece of plastic film under the gas cap.
- Tip the snow thrower up and forward so that it rests on its auger housing.

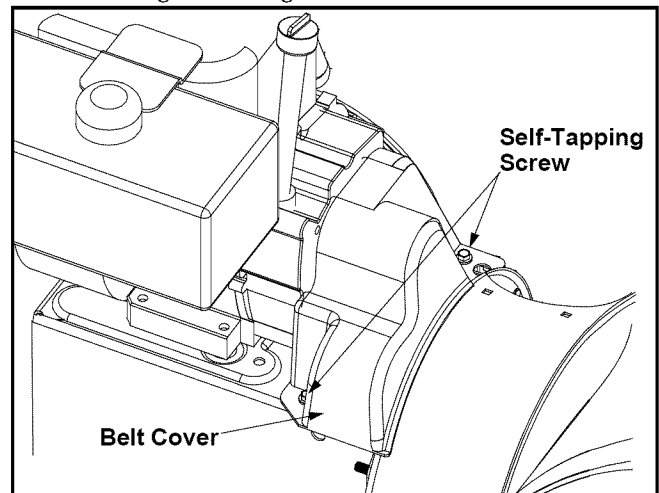
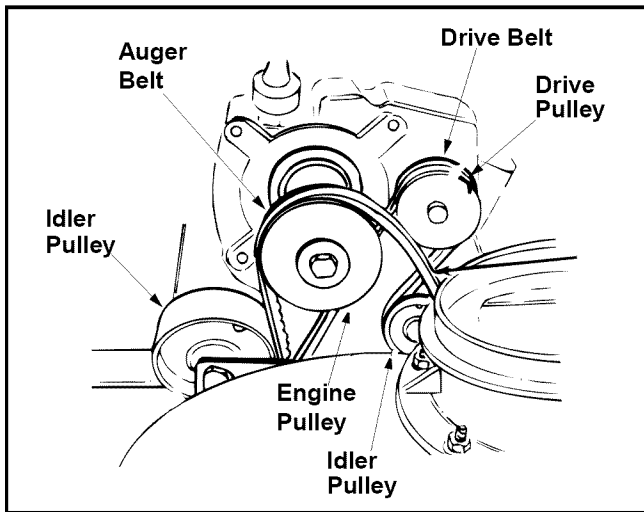

Figure 25

- Remove six self-tapping screws from the frame cover underneath the snow thrower.
- Roll auger belt off the engine pulley. See Figure 26.
- Unhook the idler spring from the hex bolt on the auger housing. See Figure 27.
- Unhook the support bracket spring from the frame.

**NOTE:** It may be necessary to loosen the six nuts that connect the frame to the auger housing to aid in belt removal.



**Figure 26**

- Lift the auger belt from the auger pulley and slip belt between the support bracket and the auger pulley. See Figure 27.
- Reassemble auger drive belt by following instructions in reverse order.

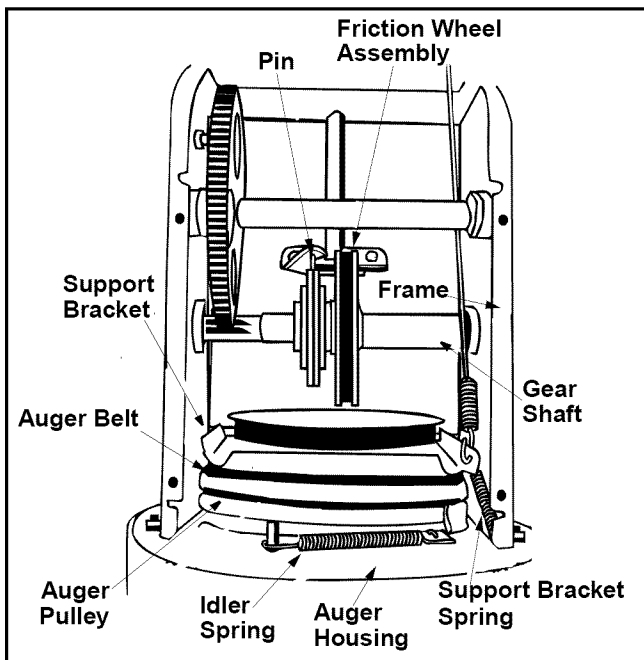

**Figure 27**

### Drive Belt

- Follow first four steps of previous instructions.
- Pull idler pulley up, and lift belt off engine pulley and friction wheel disc. See Figure 26.
- Using a wrench, loosen the nut on the stop bolt until the support bracket rests on the auger pulley. See Figure 28.
- Slip belt between friction wheel and friction wheel disc. Remove and replace belt. Reassemble in reverse order.

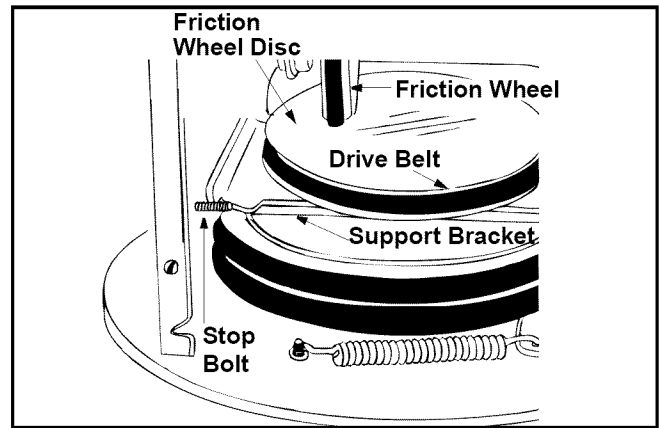

**Figure 28**

**NOTE:** The support bracket must rest on the stop bolt after the new belt has been assembled. See Figure 28.

### Friction Wheel Rubber

Replace the friction wheel rubber if any signs of wear or cracking are found. Follow instructions below to replace the rubber.

- Tip the snow thrower up and forward, so that it rests on housing. Refer to Figure 17.
- Remove six self-tapping screws from the frame cover underneath the snow thrower.
- Remove the click pins which secure the wheels, and remove the wheels from the axle.
- Using a wrench to hold the shaft, loosen, but do not completely remove, the hex nut and bell washer on the left end of gear shaft. See Figure 29.

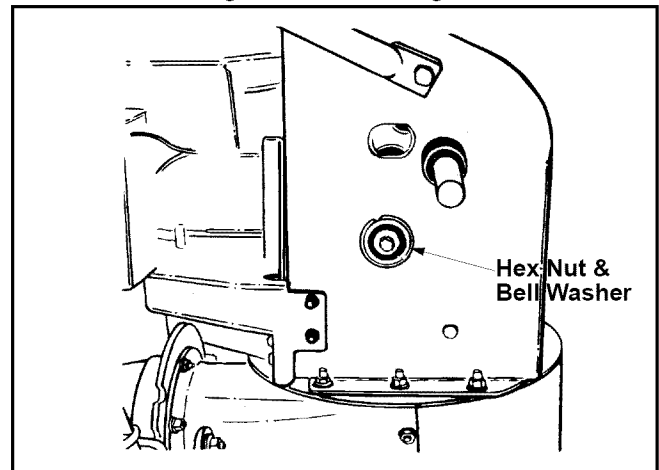

**Figure 29**

- Lightly tap the hex nut to dislodge the ball bearing from the right side of the frame. Remove the hex nut and bell washer from the left end of the shaft.
- Slide the gear shaft to the right, then slide the friction wheel assembly from the shaft.
- Remove the four screws from the friction wheel assembly. See Figure 30.
- Remove the friction wheel rubber from between the friction wheel plate.

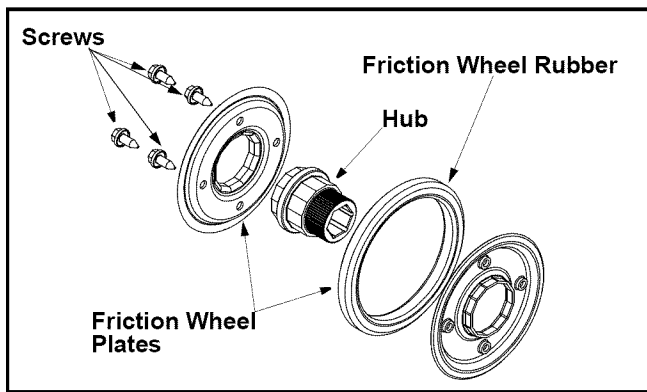

**Figure 30**

- Reassemble new friction wheel rubber to the friction wheel assembly, tightening the four screws in rotation and with equal force. See Figure 30.
- Slide friction wheel assembly back onto the gear shaft. Be sure to align the pin on the shift rod with hole in the friction wheel assembly. See Figure 27.
- Reassemble gear shaft and the wheels. Reattach the frame cover. Flip snow thrower back to its operating position and remove any plastic from under the machine or around the gas cap if you had put it there earlier.

## Off-Season Storage



**WARNING:** Never store the machine or fuel container indoors where there is an open flame, spark, or pilot light such as on water heater, furnace, clothes dryer, or other gas appliance.



**WARNING:** Drain fuel into an approved container outdoors, away from an open flame. Allow engine to cool. Extinguish cigarettes, cigars, pipes, and other sources of ignition prior to draining fuel. Fuel left in engine for extended periods deteriorates and will cause starting problems.

If unit is to be stored over 30 days, prepare for storage as follows:

- Remove gasoline from carburetor and fuel tank to prevent gum deposits from forming on these parts and causing possible malfunction of engine.
- Run engine until fuel tank is empty and engine stops due to lack of fuel.
- Drain carburetor by pressing upward on bowl drain, located below the carburetor cover.

**NOTE:** Fuel stabilizer, or “Sta-Bil” (included with certain units) is an acceptable alternative in minimizing the formation of fuel gum deposits during storage. Do not drain carburetor if using fuel stabilizer.

- Wipe equipment with an oiled rag to prevent rust.
- Remove spark plug and pour one ounce of engine oil through spark plug hole into cylinder. Cover spark plug hole with rag. Crank engine several times to distribute oil. Replace spark plug.
- Follow the lubrication recommendations found in the Maintenance Section.
- Always store the snow thrower in a clean, dry area.

**NOTE:** When storing any type of power equipment in an unventilated or metal storage shed, care should be taken to rust proof the equipment. Using a light oil or silicone, coat the equipment, especially any chains, springs, bearings and cables.

## SECTION 9: TROUBLE SHOOTING GUIDE

Trouble	Possible Cause(s)	Corrective Action
Engine fails to start	Fuel tank empty, or stale fuel. Blocked fuel line. Choke not in ON position Faulty spark plug. Key not in switch on engine. Spark plug wire disconnected. Primer button not depressed. Fuel shut-off valve closed (if so equipped).	Fill tank with clean, fresh gasoline. Fuel will not last over thirty days unless a fuel stabilizer is used. Clean fuel line. Move switch to ON position Clean, adjust gap or replace. Insert key. Connect spark plug wire. Refer to the engine manual. Open fuel shut-off valve.
Engine runs erratic	Unit running on CHOKE. Blocked fuel line or stale fuel. Water or dirt in fuel system. Carburetor out of adjustment.	Move choke lever to OFF position. Clean fuel line; fill tank with clean fresh gasoline. Fuel will not last over thirty days unless a fuel stabilizer is used. Drain fuel tank. Refill with fresh fuel. Refer to the engine manual.
Loss of power	Spark plug wire loose. Gas cap vent hole plugged. Exhaust port plugged.	Connect and tighten spark plug wire. Remove ice and snow from cap. Be certain vent hole is clear. Clean following the engine manual.
Engine overheats	Carburetor not adjusted properly. Incorrect fuel mixture.	Refer to the engine manual packed with your unit or have carburetor adjusted by an authorized service dealer. Drain fuel tank. Refill with proper fuel mixture.
Excessive vibration	Loose parts or damaged auger.	Stop engine immediately and disconnect spark plug wire. Tighten all bolts and nuts. Make all necessary repairs. If vibration continues, have unit serviced by an authorized service dealer.
Unit fails to propel itself	Incorrect adjustment of drive cable. Drive belt loose or damaged.	Adjust drive cable. Replace drive belt.
Unit fails to discharge snow	Discharge chute clogged. Foreign object lodged in auger. Incorrect adjustment of drive cable. Drive belt loose or damaged.	Stop engine immediately and disconnect spark plug wire. Clean discharge chute and inside of auger housing. Stop engine immediately and disconnect spark plug wire. Remove object from auger. Adjust drive cable. Replace drive belt.

**NOTE:** For repairs beyond the minor adjustments above, contact your local authorized service dealer.

# SECTION 10: PARTS LIST FOR MODEL 611

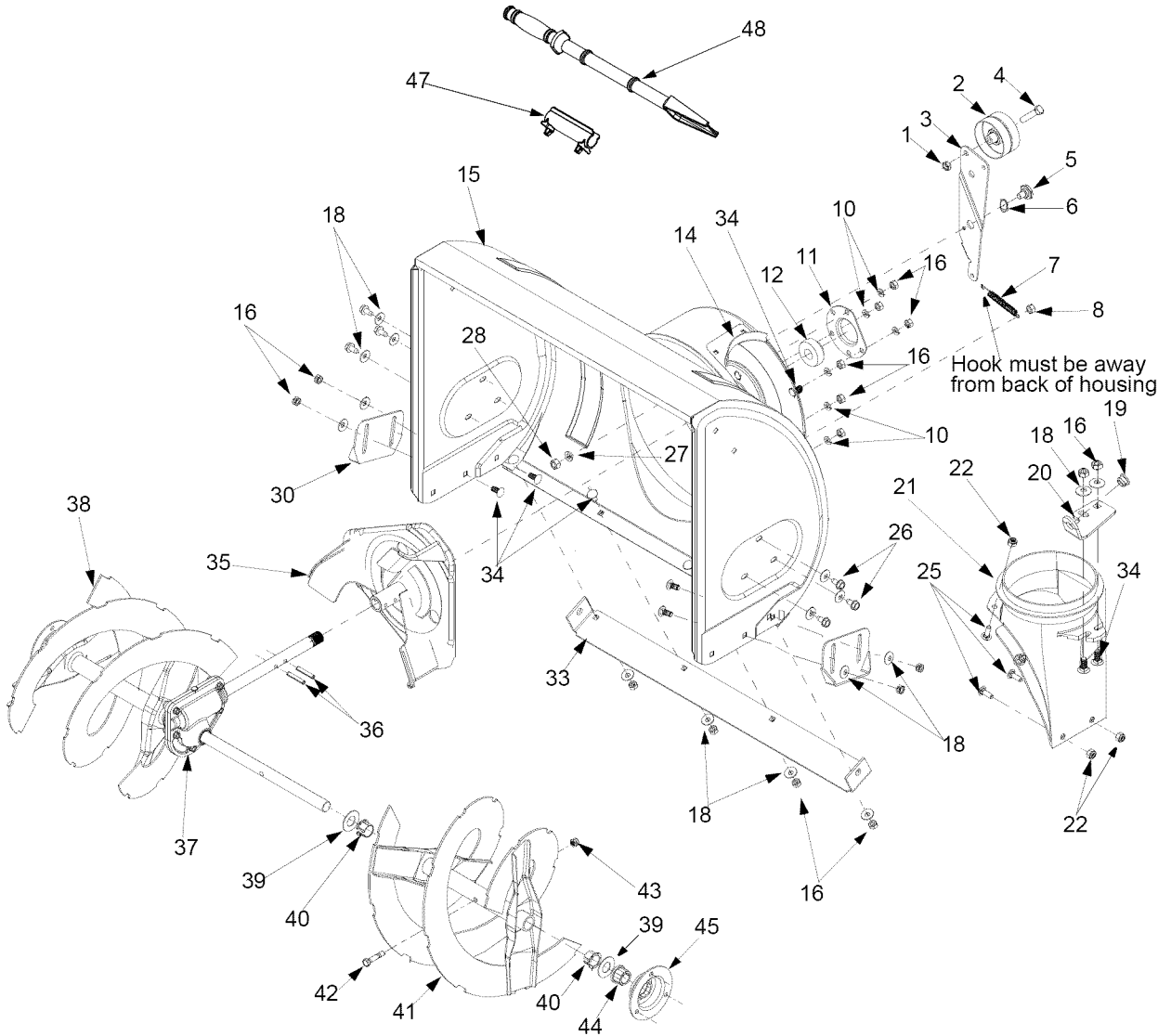

# Model 611

Ref. No.	Part No.	Description
1.	712-0116	Lock Jam Nut 3/8-24
2.	756-0178	Flat Idler
3.	784-5632B	Auger Idler Arm
4.	710-0459A	Hex Cap Screw 3/8-24 x 1.50
5.	738-0281	Shoulder Screw
6.	736-0167	Wave Washer
7.	732-0611	Extension Spring
8.	712-3068	Hex Nut 5/16-18
10.	736-0119	Lock Washer 5/16
11.	05931A	Housing
12.	741-0309	Ball Bearing
14.	705-5226	Reinforcement Chute
15.	684-0052C	22" Housing Assembly
	684-0039D	24" Housing Assembly
16.	712-3010	Hex Nut 5/16-18
18.	736-0242	Bell Washer
19.	741-0475	Bushing
20.	784-5647	Chute Directional Control Bracket
21.	731-1379C	Chute Adapter
22.	712-3027	Hex Flange Lock Nut 1/4-20
25.	710-0703	Carriage Screw 1/4-20 x.75
26.	710-0726	Screw 5/16-12
27.	736-0169	Lock Washer 3/8
28.	712-0798	Hex Nut 3/8-16
30.	784-5580	Snow Shoe
33.	784-5576	22" Shave Plate
	784-5581A	24" Shave Plate
34.	710-0451	Carriage Bolt 5/16-18 x.62
35.	684-0065	Impeller Assembly
36.	715-0114	Pin
37.	618-0152A	22" Gear Assembly
	618-0120A	24" Gear Assembly
38.	605-5252A	Spiral 22" RH
	605-5188A	Spiral 24" RH
39.	736-0188	Flat Washer
40.	741-0493A	Flange Bushing
41.	605-5253A	Spiral 22" LH
	605-5189A	Spiral 24" LH
42.	710-0890A	Shear Bolt 5/16-18 x 1.5
43.	712-0429	Lock Nut 5/16-18
44.	741-0245	Hex Flange Bearing
45.	784-5618	Bearing Housing
47.	731-2635	Clean-Out Tool Mount
48.	731-2643	Clean-Out Tool

# Model 611

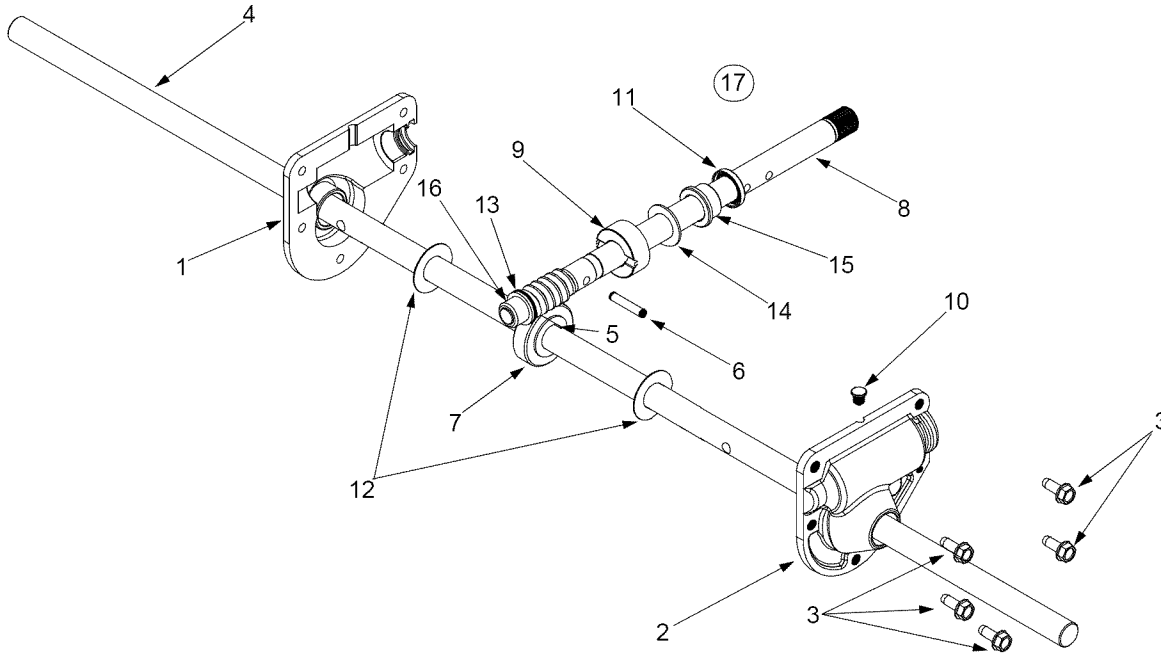

REF. NO.	PART NO.	DESCRIPTION	REF. NO.	PART NO.	DESCRIPTION
1.	618-0123	Housing—R.H.	10.	721-0325	Grease Plug
2.	618-0124	Housing—L.H.	11.	721-0327	Grease Seal
3.	710-0642	Hex Screw 1/4-20 x.75	12.	736-0351	Flat Washer.76 x 1.5 x.030
4.	711-1020A	Spiral Axle 22"	13.	736-0369	Flat Washer.508 x 1.0 x.020
	711-0908A	Spiral Axle 24"	14.	736-0445	Flat Washer.76 x 1.5 x.060
5.	714-0161	Key	15.	741-0662	Flange Bearing.75 x 1.0 x.59
6.	715-0143	Spiral Pin	16.	741-0663	Flange Bearing.75 x 1.0 x.925
7.	717-0526	Worm Gear	17.	618-0152A	Ass'y. Complete 22"
8.	717-0528A	Worm Shaft		618-0120A	Ass'y Complete 24"
9.	718-0186	Thrust Collar			

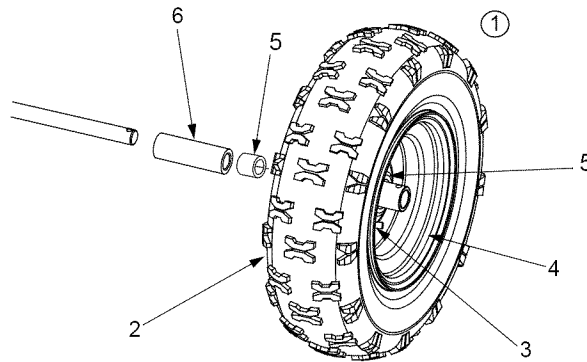

Wheel Assembly						
Size	Ref. No. 1	Ref. No. 2	Ref. No. 3	Ref. No. 4	Ref. No. 5	Ref. No. 6
	Wheel Ass'y Complete	Tire Only	Air Valve	Rim Only	Sleeve Bearing (2)	Spacer
13 x 4	634-0114A	734-1732	734-0255	734-1713A	741-0401	731-04044
13 x 5	734-1714A	734-1527	734-0255	734-1713A	741-0401	731-04044

# Model 611

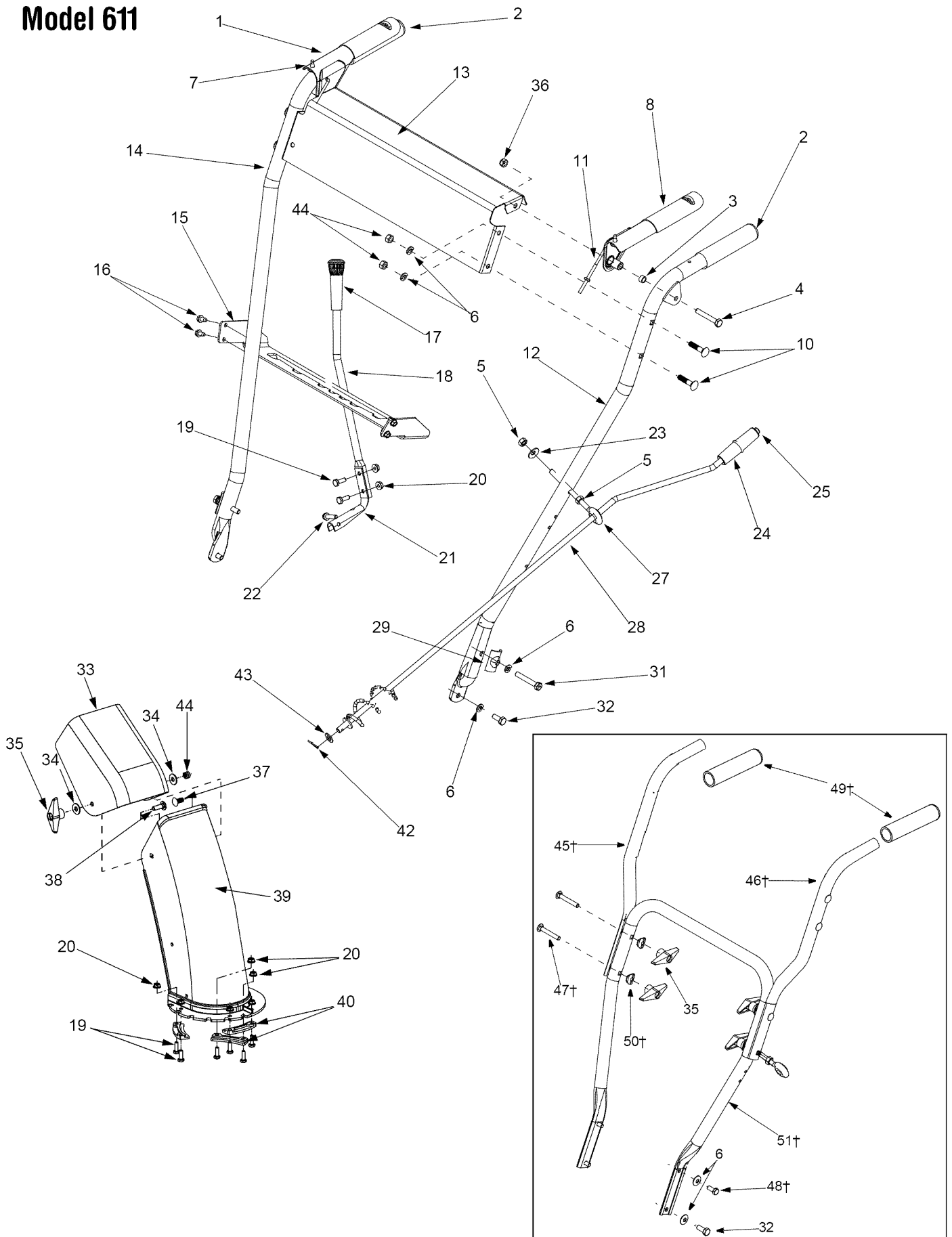

†Models w/Folding Handles



# Model 611

Ref. No.	Part No.	Description	Ref. No.	Part No.	Description
1.	705-5234A 684-04053	Clutch Lever Assembly RH - Black Clutch Lever Assembly RH - Yellow	25.	726-0100	Push Cap
2.	720-0204	Grip	27.	747-0697	Eyebolt
3.	750-1032	Spacer.325 ID x.460 OD	-	735-0234	Grommet only
4.	710-3103	Hex Cap Screw 5/16 -18 x 2.0	28.	705-5204A	Chute Directional Control Assembly
5.	712-3010	Hex Nut 5/16-18	29.	784-5599	Handle Tab
6.	736-0119	Lock Washer 5/16	31.	710-04039	Hex Cap Screw 5/16-18 x 2.00
7.	735-0199A	Rubber Bumper	32.	710-1880	Hex Cap Screw 5/16-18 x.75
8.	705-5233A 684-04054	Clutch Lever Assembly LH - Black Clutch Lever Assembly LH - Yellow	33.	731-04426	Upper Chute
10.	710-0262	Carriage Bolt 5/16-18 x 1.50	34.	736-0159	Washer 5/16
11.	746-0778	Z - Cable Fitting	35.	720-0284	Knob - Black
12.	684-0047A	Handle - LH		720-04032	Knob - Yellow
13.	705-5232A	Handle Panel	36.	712-0429	Hex Lock Nut 5/16-18
14.	684-0048A	Handle - RH	37.	710-0451	Carriage Bolt 5/16-18 x.75
15.	705-5231	Speed Select Panel	38.	710-04071	Carriage Screw 5/16-18 x 1.0
16.	710-0599	Hex Washer Screw 1/4-20 x.50	39.	731-1300B	Lower Chute
17.	720-0223	Grip	40.	731-0851A	Flange Keeper
18.	747-0904	Shift Lever	42.	714-0104	Cotter Pin
19.	710-3015	Hex Cap Screw 1/4-20 x.75	43.	736-0185	Flat Washer 3/8
20.	712-3027	Hex Lock Nut 1/4-20	44.	712-3068	Hex Patch Nut 5/16-18 Gr. 5
21.	732-0733	Shift Lever Spring	45.	684-04038†	Upper Handle RH
22.	710-0788	Hex Washer Screw 1/4-20 x 1.0	46.	684-04039†	Upper Handle LH
23.	736-0242	Bell Washer	47.	710-0449†	Carriage Screw 5/16-18 x 2.25
24.	720-0201A 720-04031	Chute Knob - Black Chute Knob - Yellow	48.	710-0643†	Hex Cap Screw 5/16-18 x 1.00
			49.	720-0274†	Grip
			50.	736-0451†	Saddle Washer
			51.	749-0951†	Lower Handle

†Models w/Folding Handles

**NOTE:** Snow thrower features vary by model. NOT all parts listed above and pictured on the previous page are standard equipment.

# Model 611

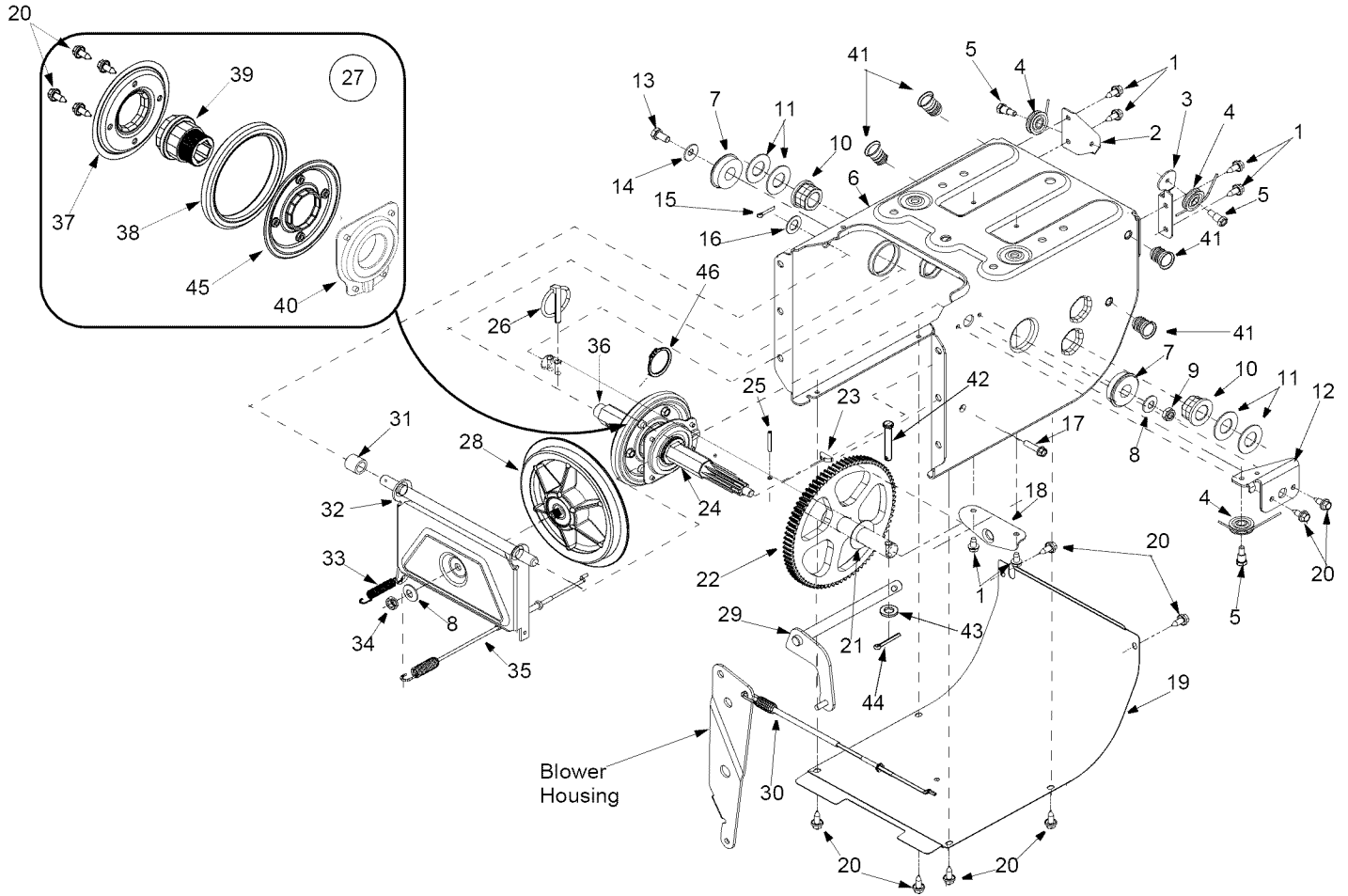

Ref. No.	Part No.	Description	Ref. No.	Part No.	Description
1.	710-0599	Self-Tapp. Screw 1/4-20 x 0.5"	25.	715-0249	Roll Pin
2.	784-5688	Drive Cable Guide Bracket	26.	714-0143	Click Pin
3.	784-5687A	Auger Clutch Cable Bracket	27.	684-0042C	Friction Wheel Assembly
4.	756-0625	Roller Cable	28.	656-0012A	Friction Disc Wheel
5.	738-0924	Hex Screw 1/4-28	29.	684-0013B	Wheel Shift Rod Assembly
6.	784-5630B	Frame Assembly	30.	746-0897	Drive Cable
7.	741-0563	Ball Bearing	31.	748-0190	Spacer
8.	736-0105	Bell Washer	32.	684-0021	Friction Wheel Bracket Assembly
9.	712-0116	Lock Jam Nut	33.	732-0264	Extension Spring
10.	741-4026	Hex Flange Bearing	34.	712-0711	Jam Nut 3/8-24
11.	736-0188	Flat Washer	35.	746-0898B	Drive Cable
12.	784-5689A	Front Support Guide Bracket	36.	738-0869	22.2" Axle (used w/ 13 x 4 tire)
13.	710-0538	Lock Hex Screw		738-0991	21.4" Axle (used w/ 13 x 5 tire)
14.	736-0242	Bell Washer.340 ID x.872 OD	37.	790-00010	Friction Plate
15.	714-0474	Cotter Pin	38.	735-0243B	Friction Wheel Rubber
16.	736-0160	Flat Washer.536 ID x.930 OD	39.	718-0301A	Friction Wheel Hub
17.	710-0809	Self Tapp. Screw 1/4-20 x 1.25"	40.	618-0063A	Friction Wheel Bearing Assembly
18.	784-5590	Frame Shift Bracket	41.	712-0703A	Nut Insert
19.	784-5638A	Frame Cover	42.	711-1364	Clevis Pin
20.	710-1652	Hex Washer Screw 1/4-20	43.	736-0142	Flat Washer.281 ID x.50 OD
21.	736-0351	Flat Washer.760 ID x.50 OD	44.	714-0507	Cotter Pin
22.	717-1445	Gear	45.	790-00011	Friction Plate
23.	714-0126	Key	46.	716-0102	Snap Ring
24.	717-04094	7-Tooth Shaft			

# Model 611

**IMPORTANT:** For a proper working machine, use Factory Approved Parts.  
**V-BELTS** are specially designed to engage and disengage safely. A substitute (non OEM) V-Belt can be dangerous by not disengaging completely.

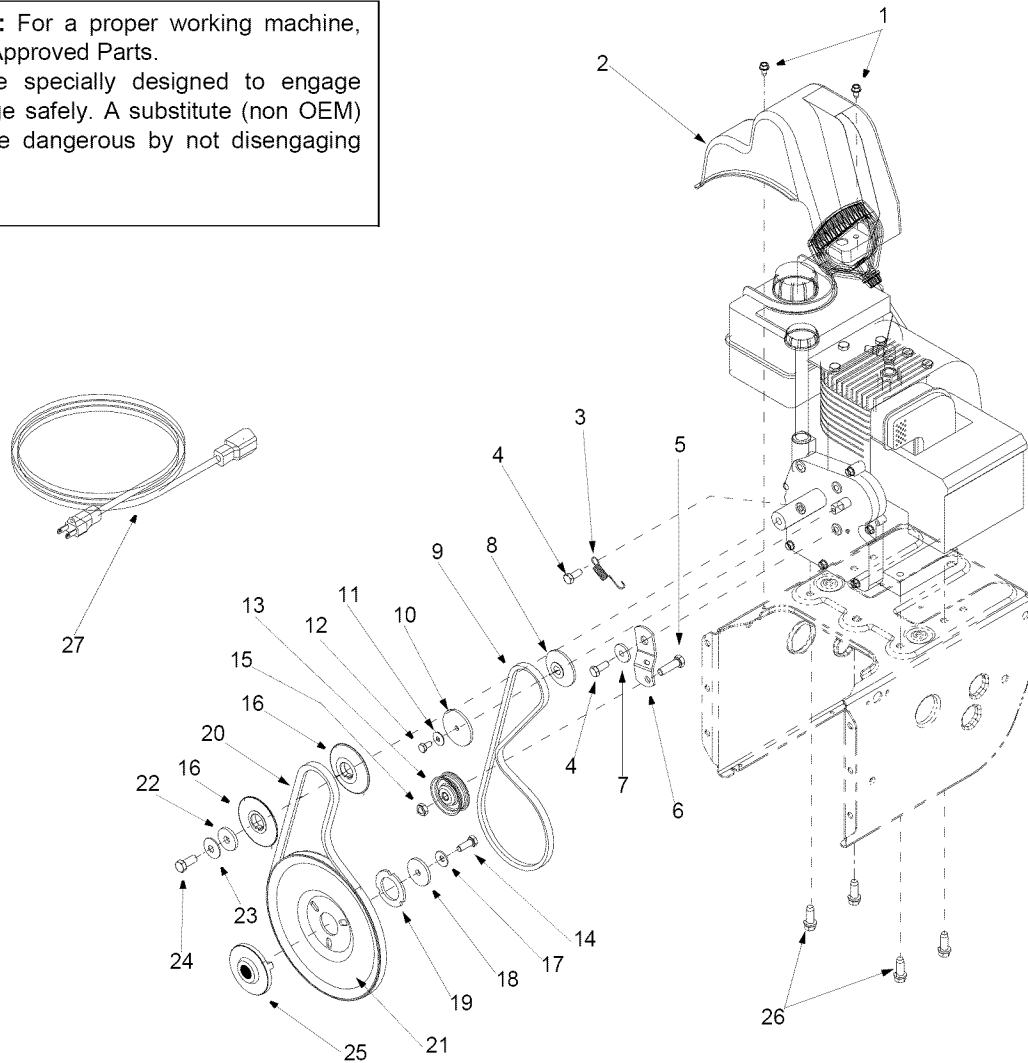

Ref. No.	Part No.	Description	Ref. No.	Part No.	Description
1.	710-1652	Hex Washer Screw 1/4-20 x.625	15.	712-0181	Lock Jam Nut 3/8-16
2.	731-1324	Belt Cover	16.	756-0569	Pulley Half
3.	732-0339	Extension Spring	17.	736-0242	Bell Washer
4.	710-0627	Hex Screw 5/16-24 x.75	18.	736-0505	Flat Washer
5.	710-3005	Hex Cap Screw 3/8-16 x 1.25	19.	736-0507	Washer
6.	05896A	Drive Clutch Bracket	20.	754-0430B	Belt
7.	748-0234	Shoulder Spacer	21.	756-0967	Auger Pulley
8.	756-0985	Pulley Half	22.	736-0247	Flat Washer
9.	754-0343	V-Belt	23.	736-0331	Bell Washer
10.	756-0984	Pulley Half	24.	710-0696	Hex Cap Screw 3/8-24
11.	736-0270	Bell Washer	25.	748-0360	Pulley
12.	710-0230	Hex Cap Screw 1/4-28 x.50	26.	710-0654A	Hex Washer Screw 3/8-16 x 1.0
13.	756-0313	Flat Idler	27.	629-0071†	Extension Cord
14.	710-1245B	Lock Cap Screw 5/16-24		OEM-390-986	Electric Start Kit

† If Equipped

# MANUFACTURER'S LIMITED WARRANTY FOR:



The limited warranty set forth below is given by MTD LLC with respect to new merchandise purchased and used in the United States, its possessions and territories.

"MTD" warrants this product against defects in material and workmanship for a period of two (2) years commencing on the date of original purchase and will, at its option, repair or replace, free of charge, any part found to be defective in materials or workmanship. This limited warranty shall only apply if this product has been operated and maintained in accordance with the Operator's Manual furnished with the product, and has not been subject to misuse, abuse, commercial use, neglect, accident, improper maintenance, alteration, vandalism, theft, fire, water, or damage because of other peril or natural disaster. Damage resulting from the installation or use of any part, accessory or attachment not approved by MTD for use with the product(s) covered by this manual will void your warranty as to any resulting damage.

Normal wear parts or components thereof are subject to separate terms as follows: All normal wear parts or component failures will be covered on the product for a period of 90 days regardless of cause. After 90 days, but within the two year period, normal wear part failures will be covered ONLY IF caused by defects in materials or workmanship of OTHER component parts. Normal wear parts and components include, but are not limited to: batteries, belts, blades, blade adapters, grass bags, rider deck wheels, seats, snow thrower skid shoes, shave plates, auger spiral rubber, and tires.

**HOW TO OBTAIN SERVICE:** Warranty service is available, WITH PROOF OF PURCHASE, through your local authorized service dealer. To locate the dealer in your area, check your Yellow Pages, or contact MTD LLC at P.O. Box 361131, Cleveland, Ohio 44136-0019, or call 1-800-800-7310 or 1-330-220-4683 or log on to our Web site at [www.mtdproducts.com](http://www.mtdproducts.com).

This limited warranty does not provide coverage in the following cases:

- a. The engine or component parts thereof. These items may carry a separate manufacturer's warranty. Refer to applicable manufacturer's warranty for terms and conditions.
- b. Log splitter pumps, valves, and cylinders have a separate one year warranty.
- c. Routine maintenance items such as lubricants, filters, blade sharpening, tune-ups, brake adjustments, clutch adjustments, deck adjustments, and normal deterioration of the exterior finish due to use or

exposure.

- d. MTD does not extend any warranty for products sold or exported outside of the United States, its possessions and territories, except those sold through MTD's authorized channels of export distribution.
- e. Replacement parts that are not genuine MTD parts.
- f. Service completed by someone other than an authorized service dealer.
- g. Transportation charges and service calls.

**No implied warranty, including any implied warranty of merchantability of fitness for a particular purpose, applies after the applicable period of express written warranty above as to the parts as identified. No other express warranty, whether written or oral, except as mentioned above, given by any person or entity, including a dealer or retailer, with respect to any product, shall bind MTD. During the period of the warranty, the exclusive remedy is repair or replacement of the product as set forth above.**

**The provisions as set forth in this warranty provide the sole and exclusive remedy arising from the sale. MTD shall not be liable for incidental or consequential loss or damage including, without limitation, expenses incurred for substitute or replacement lawn care services or for rental expenses to temporarily replace a warranted product.**

Some states do not allow the exclusion or limitation of incidental or consequential damages, or limitations on how long an implied warranty lasts, so the above exclusions or limitations may not apply to you.

In no event shall recovery of any kind be greater than the amount of the purchase price of the product sold. **Alteration of safety features of the product shall void this warranty.** You assume the risk and liability for loss, damage, or injury to you and your property and/or to others and their property arising out of the misuse or inability to use the product.

This limited warranty shall not extend to anyone other than the original purchaser or to the person for whom it was purchased as a gift.

**HOW STATE LAW RELATES TO THIS WARRANTY:** This limited warranty gives you specific legal rights, and you may also have other rights which vary from state to state.

**IMPORTANT:** Owner must present Original Proof of Purchase to obtain warranty coverage.