

OPERATOR'S MANUAL

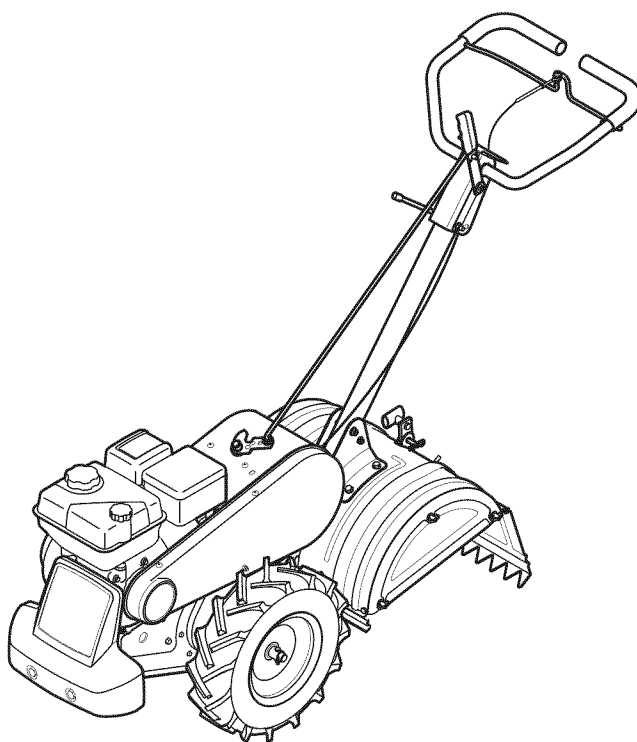

Rear Tine Tiller — Model Series 450

⚠ WARNING

**READ AND FOLLOW ALL SAFETY RULES AND INSTRUCTIONS IN THIS MANUAL
BEFORE ATTEMPTING TO OPERATE THIS MACHINE.
FAILURE TO COMPLY WITH THESE INSTRUCTIONS MAY RESULT IN PERSONAL INJURY.**

MTD LLC, P.O. BOX 361131 CLEVELAND, OHIO 44136-0019

Thank You

Thank you for purchasing a Garden Tiller manufactured by MTD LLC. It was carefully engineered to provide excellent performance when properly operated and maintained.

Please read this entire manual prior to operating the equipment. It instructs you how to safely and easily set up, operate and maintain your machine. Please be sure that you, and any other persons who will operate the machine, carefully follow the recommended safety practices at all times. Failure to do so could result in personal injury or property damage.

All information in this manual is relative to the most recent product information available at the time of printing. Review this manual frequently to familiarize yourself with the machine, its features and operation. Please be aware that this Operator's Manual may cover a range of product specifications for various models. Characteristics and features discussed and/or illustrated in this manual may not be applicable to all models. MTD LLC reserves the right to change product specifications, designs and equipment without notice and without incurring obligation.

If you have any problems or questions concerning the machine, phone your local authorized MTD service dealer or contact us directly. MTD's Customer Support telephone numbers, website address and mailing address can be found on this page. We want to ensure your complete satisfaction at all times.

Throughout this manual, all references to *right* and *left* side of the machine are observed from the operating position

Table of Contents

Safe Operation Practices	3	Engine Maintenance	16
Assembly & Set-Up	7	Service	20
Controls & Features.....	11	Troubleshooting.....	21
Operation.....	12	Replacement Parts	22
Maintenance & Adjustment.....	14	Warranty	Back Cover

Record Product Information

Before setting up and operating your new equipment, please locate the model plate on the equipment and record the information in the provided area to the right. You can locate the model plate by standing at the operator's position and looking down at the front right corner of the tine shield. This information will be necessary, should you seek technical support via our web site, Customer Support Department, or with a local authorized service dealer.

MODEL NUMBER

--	--	--	--	--	--	--	--	--	--	--	--

SERIAL NUMBER

--	--	--	--	--	--	--	--	--	--	--	--

Customer Support

Please do NOT return the machine to the retailer or dealer without first contacting our Customer Support Department.

If you have difficulty assembling this product or have any questions regarding the controls, operation, or maintenance of this machine, you can seek help from the experts. Choose from the options below:

- ◇ Visit us on the web at www.mtdproducts.com
- ◇ Call a Customer Support Representative at (800) 800-7310 or (330) 220-4683
- ◇ Write us at MTD LLC • P.O. Box 361131 • Cleveland, OH • 44136-0019



WARNING! This symbol points out important safety instructions which, if not followed, could endanger the personal safety and/or property of yourself and others. Read and follow all instructions in this manual before attempting to operate this machine. Failure to comply with these instructions may result in personal injury.

When you see this symbol. **HEED ITS WARNING!**

CALIFORNIA PROPOSITION 65



WARNING! Engine Exhaust, some of its constituents, and certain vehicle components contain or emit chemicals known to State of California to cause cancer and birth defects or other reproductive harm.



WARNING! Battery posts, terminals, and related accessories contain lead and lead compounds, chemicals known to the State of California to cause cancer and reproductive harm. *Wash hands after handling*



DANGER! This machine was built to be operated according to the safe operation practices in this manual. As with any type of power equipment, carelessness or error on the part of the operator can result in serious injury. This machine is capable of amputating fingers, hands, toes and feet. Failure to observe the following safety instructions could result in serious injury or death.

Training

1. Read, understand, and follow all instructions on the machine and in the manual(s) before attempting to assemble and operate. Keep this manual in a safe place for future and regular reference and for ordering replacement parts.
2. Be familiar with all controls and their proper operation. Know how to stop the machine and disengage them quickly.
3. Never allow children under 14 years of age to operate this machine. Children 14 and over should read and understand the instructions and safe operation practices in this manual and on the machine and be trained and supervised by an adult.
4. Never allow adults to operate this machine without proper instruction.
5. Keep the area of operation clear of all persons, particularly small children and pets. Stop machine if anyone enters the area.
2. Wear sturdy, rough-soled work shoes and close fitting slacks and shirt. Loose fitting clothes or jewelry can be caught in moving parts. Never operate this machine in bare feet or sandals.
3. Disengage clutch levers and shift (if provided) into neutral ("N") before starting the engine.
4. Never leave this machine unattended with the engine running.
5. Never attempt to make any adjustments while engine is running, except where specifically recommended in the operator's manual.

Safe Handling of Gasoline:

To avoid personal injury or property damage use extreme care in handling gasoline. Gasoline is extremely flammable and the vapors are explosive. Serious personal injury can occur when gasoline is spilled on yourself or your clothes which can ignite. Wash your skin and change clothes immediately.

- a. Use only an approved gasoline container.
- b. Never fill containers inside a vehicle or on a truck or trailer bed with a plastic liner. Always place containers on the ground away from your vehicle before filling.

Preparation

1. Thoroughly inspect the area where the equipment is to be used. Remove all stones, sticks, wire, and other foreign objects which could be tripped over and cause personal injury.

- c. When practical, remove gas-powered equipment from the truck or trailer and refuel it on the ground. If this is not possible, then refuel such equipment on a trailer with a portable container, rather than from a gasoline dispenser nozzle.
 - d. Keep the nozzle in contact with the rim of the fuel tank or container opening at all times until fueling is complete. Do not use a nozzle lock-open device.
 - e. Extinguish all cigarettes, cigars, pipes and other sources of ignition.
 - f. Never fuel machine indoors.
 - g. Never remove gas cap or add fuel while the engine is hot or running. Allow engine to cool at least two minutes before refueling.
 - h. Never over fill fuel tank. Fill tank to no more than ½ inch below bottom of filler neck to allow space for fuel expansion.
 - i. Replace gasoline cap and tighten securely.
 - j. If gasoline is spilled, wipe it off the engine and equipment. Move unit to another area. Wait 5 minutes before starting the engine.
 - k. To reduce fire hazards, keep machine free of grass, leaves, or other debris build-up. Clean up oil or fuel spillage and remove any fuel soaked debris.
 - l. Never store the machine or fuel container inside where there is an open flame, spark or pilot light as on a water heater, space heater, furnace, clothes dryer or other gas appliances.
- 11. After striking a foreign object, stop the engine, disconnect the spark plug wire and ground against the engine. Thoroughly inspect the machine for any damage. Repair the damage before starting and operating.
 - 12. Disengage all clutch levers (if fitted) and stop engine before you leave the operating position (behind the handles). Wait until the tines come to a complete stop before unclogging the tines, making any adjustments, or inspections.
 - 13. Never run an engine indoors or in a poorly ventilated area. Engine exhaust contains carbon monoxide, an odorless and deadly gas.
 - 14. Muffler and engine become hot and can cause a burn. Do not touch.
 - 15. Use caution when tilling near fences, buildings and underground utilities. Rotating tines can cause property damage or personal injury.
 - 16. Do not overload machine capacity by attempting to till soil too deep at too fast of a rate.
 - 17. If the machine should start making an unusual noise or vibration, stop the engine, disconnect the spark plug wire and ground it against the engine. Inspect thoroughly for damage. Repair any damage before starting and operating.
 - 18. Keep all shields, guards, and safety devices in place and operating properly.
 - 19. Never pick up or carry machine while the engine is running.
 - 20. Use only attachments and accessories approved by the manufacturer. Failure to do so can result in personal injury.
 - 21. If situations occur which are not covered in this manual, use care and good judgement. Contact Customer Support for assistance and the name of you nearest servicing dealer..

Operation

1. Do not put hands or feet near rotating parts. Contact with the rotating parts can amputate hands and feet.
2. Do not operate machine while under the influence of alcohol or drugs.
3. Never operate this machine without good visibility or light. Always be sure of your footing and keep a firm hold on the handles.
4. Keep bystanders away from the machine while it is in operation. Stop the machine if anyone enters the area.
5. Be careful when tilling in hard ground. The tines may catch in the ground and propel the tiller forward. If this occurs, let go of the handle bars and do not restrain the machine.
6. Exercise extreme caution when operating on or crossing gravel surfaces. Stay alert for hidden hazards or traffic. Do not carry passengers.
7. Never operate the machine at high transport speeds on hard or slippery surfaces.
8. Exercise caution to avoid slipping or falling.
9. Look down and behind and use care when in reverse or pulling machine towards you.
10. Start the engine according to the instructions found in this manual and keep feet well away from the tines at all times.

Maintenance & Storage

1. Keep machine, attachments and accessories in safe working order.
2. Allow a machine to cool at least five minutes before storing. Never tamper with safety devices. Check their proper operation regularly.
3. Check bolts and screws for proper tightness at frequent intervals to keep the machine in safe working condition. Also, visually inspect machine for any damage.
4. Before cleaning, repairing, or inspecting, stop the engine and make certain the tines and all moving parts have stopped. Disconnect the spark plug wire and ground it against the engine to prevent unintended starting.
5. Do not change the engine governor settings or over-speed the engine. The governor controls the maximum safe operating speed of engine.
6. Maintain or replace safety and instruction labels, as necessary.
7. Follow this manual for safe loading, unloading, transporting, and storage of this machine.
8. Always refer to the operator's manual for important details if the machine is to be stored for an extended period.

9. If the fuel tank has to be drained, do this outdoors.
10. Observe proper disposal laws and regulations for gas, oil, etc. to protect the environment.
11. According to the Consumer Products Safety Commission (CPSC) and the U.S. Environmental Protection Agency (EPA), this product has an *Average Useful Life* of seven (7) years, or 130 hours of operation. At the end of the *Average Useful Life* have the machine inspected annually by an authorized service dealer to ensure that all mechanical and safety systems are working properly and not worn excessively. Failure to do so can result in accidents, injuries or death.

Notice Regarding Emissions

Engines which are certified to comply with California and federal EPA emission regulations for SORE (Small Off Road Equipment) are certified to operate on regular unleaded gasoline, and may include the following emission control systems: Engine Modification (EM), Oxidizing Catalyst (OC), Secondary Air Injection (SAI) and Three Way Catalyst (TWC) if so equipped.

Spark Arrester









WARNING! This machine is equipped with an internal combustion engine and should not be used on or near any unimproved forest-covered, brushcovered or grass-covered land unless the engine's exhaust system is equipped with a spark arrester meeting applicable local or state laws (if any).

If a spark arrester is used, it should be maintained in effective working order by the operator. In the State of California the above is required by law (Section 4442 of the California Public Resources Code). Other states may have similar laws. Federal laws apply on federal lands.

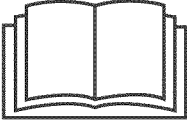
A spark arrester for the muffler is available through your nearest engine authorized service dealer or contact the service department, P.O. Box 361131 Cleveland, Ohio 44136-0019.

Safety Symbols

This page depicts and describes safety symbols that may appear on this product. Read, understand, and follow all instructions on the machine before attempting to assemble and operate.

Symbol	Description
	READ THE OPERATOR'S MANUAL(S) Read, understand, and follow all instructions in the manual(s) before attempting to assemble and operate.
	WARNING— ROTATING TINES Do not put hands or feet near rotating parts. Contact with the rotating parts can amputate hands and feet.
	WARNING— ROTATING TINES Do not put hands or feet near rotating parts. Contact with the rotating parts can amputate hands and feet.
	WARNING— GASOLINE IS FLAMMABLE Allow the engine to cool at least two minutes before refueling.
	WARNING— CARBON MONOXIDE Never run an engine indoors or in a poorly ventilated area. Engine exhaust contains carbon monoxide, an odorless and deadly gas.
	WARNING— HOT SURFACE Engine parts, especially the muffler, become extremely hot during operation. Allow engine and muffler to cool before touching.



WARNING! Your Responsibility—Restrict the use of this power machine to persons who read, understand and follow the warnings and instructions in this manual and on the machine.

SAVE THESE INSTRUCTIONS!

Contents of Carton

- One Tiller
- One Depth Stake
- One Handlebar Assembly
- One Operator's Manual
- One Shift Rod
- One Engine Operator's Manual

NOTE: This operator's manual covers various models of tillers. The tiller illustrated may vary slightly from your machine. Follow only those instructions which pertain to your model number.

Assembly

Unpacking Instructions

NOTE: References to the right or left side of the tiller are determined from behind the machine in the operating position.

1. Remove the staples, break the glue on the top flaps, or cut the tape at the end of the carton and peel it along the top flap to open.
2. Remove any loose parts included with the tiller (i.e., the Operator's Manual, etc.).
3. Cut the corners and lay the carton down flat.
4. Remove the packing material.
5. Roll or slide the tiller out of the carton. Check the carton thoroughly for loose parts.
6. Extend the control cable and lay it on the floor. Be careful not to bend or kink the control cable.

NOTE: This machine is shipped without gasoline or oil in the engine. Be certain to service the engine with gasoline and oil as instructed in the separate Engine Operator's Manual before operating.

Depth Stake



WARNING! Before assembly, disconnect the spark plug wire and ground it against the engine to prevent unintended starting.

1. Tip the tiller forward so that it rests on the front counterweight.
2. Unthread the "T" knob from the top of the depth stake and remove the flat washer and hex bolt. Remove the cotter pin from the clevis pin. See Fig. 3-1.

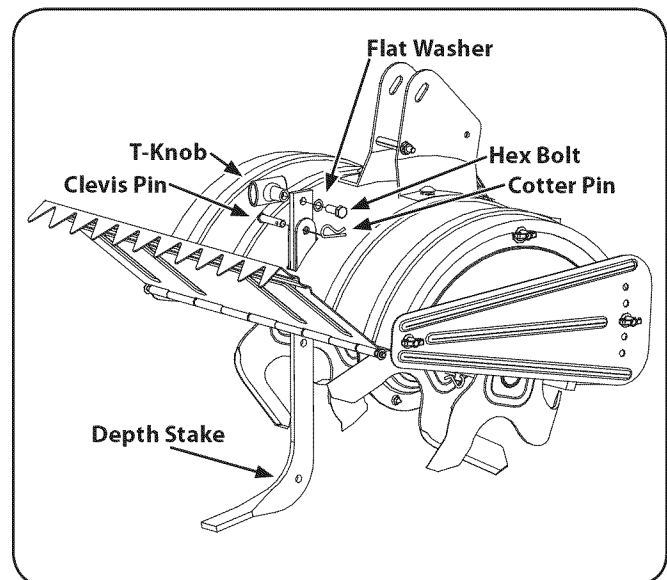

Figure 3-1

3. Raise the tine shield hinge flap assembly and insert the depth stake assembly in the slot, under the tine shield and up through the tine shield assembly.
4. Insert the clevis pin through the tine shield and depth stake assemblies. Secure it with the cotter pin.
5. Insert the hex bolt into the top hole of the depth stake assembly. Place the flat washer on the hex bolt and thread the T-knob onto the hex bolt. Tighten securely. See Fig. 3-1.
6. Tip the tiller back down so that it rests on the tines.

Handlebar Assembly

1. Remove the top two bolts and flange lock nuts from the handle mounting brackets, but do not remove the bottom bolt and nut. See Fig. 3-2.

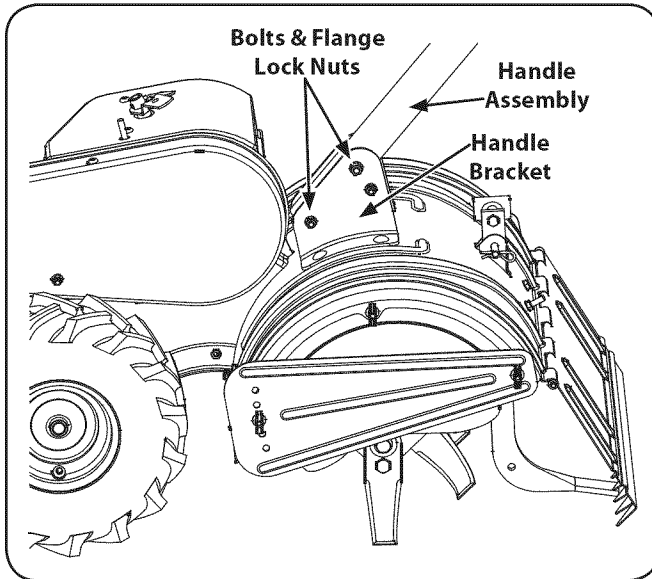

Figure 3-2

2. Place the handle assembly in position between the handle mounting brackets.
3. Line up the holes in the handle with the holes in the bracket and secure with the hardware previously removed.

Clutch Cable

1. Remove the threaded eyebolt and nut from the cable end.
2. Route the clutch cable to the right side of the handle mounting brackets and underneath the handle.
3. Push the cable through the hole in the center of the handle and snap in the plastic fitting. See Fig. 3-3.

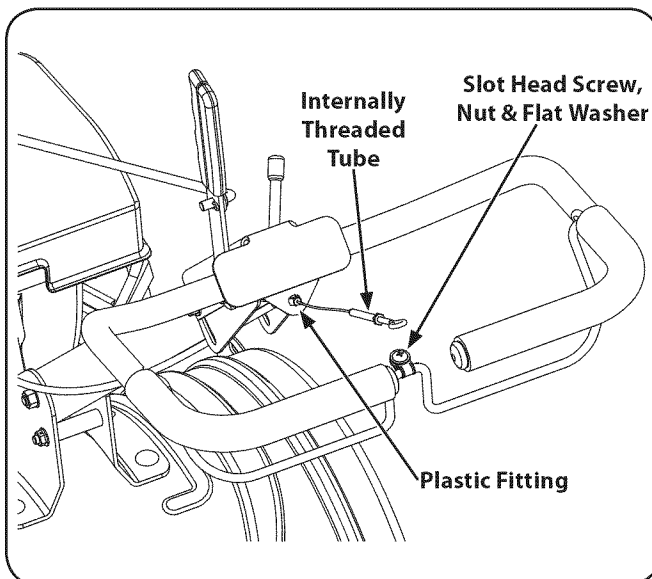

Figure 3-3

4. Remove the slot head screw, nut and two flat washers from the clutch bail. See Fig. 3-4.

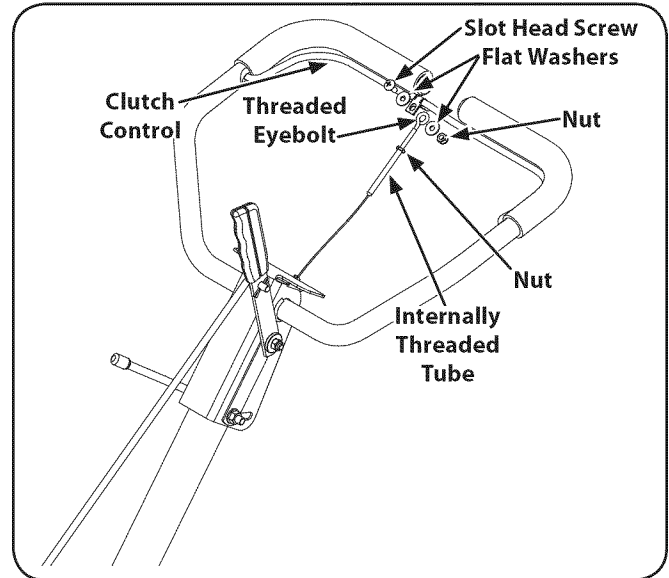

Figure 3-4

5. Fasten the threaded eyebolt onto the bail by securing it from the top with the slot head screw, flat washers and lock nut.
6. Thread the eyebolt and nut removed earlier into the internally threaded tube at the end of the cable. The thread engagement should be about $\frac{3}{4}$ ". Tighten the nut against the tube at the end of the cable. See Fig. 3-4.

NOTE: Do not overtighten the clutch cable. Too much tension may cause it to break.



WARNING! Be certain to check the clutch cable adjustment before operating the tiller.

Control Rod

1. Make sure the handle assembly is in the highest position. Refer to the Controls & Features Section.
2. Remove the hairpin clips from the control rod, put the rubber washers in place.
3. Insert the shorter, angled end of the control rod through the indicator bracket on the shift cover and secure it with the previously removed hairpin clip. See Fig. 3-5.

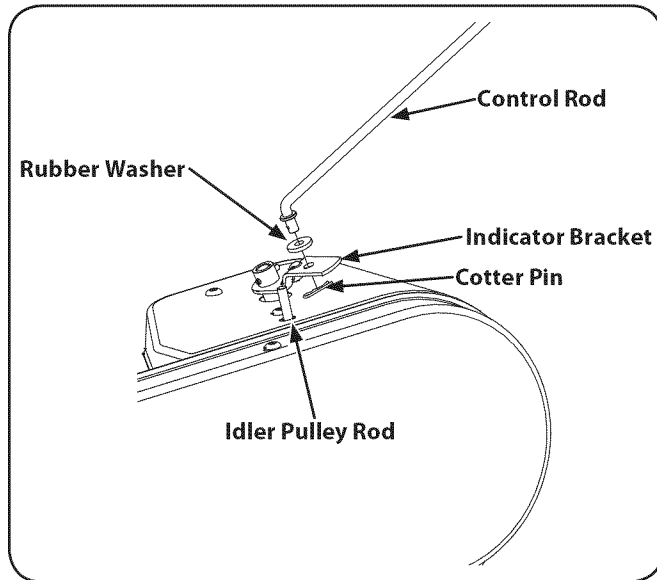

Figure 3-5

4. Insert the longer end of the control rod through the hole in the gear selector handle and secure with a cotter pin.

Adjustments

Clutch Cable

NOTE: Service the engine with oil and gasoline before checking this adjustment. Refer to the separate Engine Operator's Manual packed with your tiller for proper fuel and engine oil recommendations.

1. Position the tiller so the front counterweight is against a solid object, such as a wall.
2. With the gear selection lever in NEUTRAL, start the engine. Refer to the separate Engine Operator's Manual.
3. Standing on the right side of the tiller, examine the belt (inside the belt cover). It should not be turning.



WARNING! Do not put your fingers under the belt cover.

4. If the belt turns without the bail engaged, adjust it by unthreading the internally threaded tube at the end of the cable a few turns clockwise — when standing in the operator's position — and then retighten the nut against the tube.
5. Now move the shift lever to the FORWARD position.
6. Carefully engage the clutch by lifting the clutch control bail against the handle. The wheels should spin.
7. If the wheels do not spin with the tiller in forward, adjust by unthreading the tube at the end of the cable a few turns counter-clockwise — when standing in operator's position — and then retighten the nut against the tube.
8. Recheck both adjustments, and readjust as necessary.

NOTE: A secondary cable adjustment is available if you reach the point that additional adjustment is needed. Remove the belt cover and move the hex nuts at the other end of the cable towards the end of the casing. Then readjust the hex nuts at the handle.

Set-Up

Tires

The tires on your tiller may be over-inflated for shipping purposes. Reduce the tire pressure before operating the tiller. Recommended operating tire pressure is approximately 20 p.s.i. (check the sidewall of the tire for the manufacturer's recommended pressure).



WARNING! Maximum tire pressure under any circumstances is 30 p.s.i. Equal tire pressure should be maintained on both tires.

Gas & Oil Fill-Up

Service the engine with gasoline and oil as instructed in the separate engine manual packed with your tiller. Read the instructions carefully.



WARNING! Use extreme care when handling gasoline. Gasoline is extremely flammable and the vapors are explosive. Never fuel the machine indoors or while the engine is hot or running.

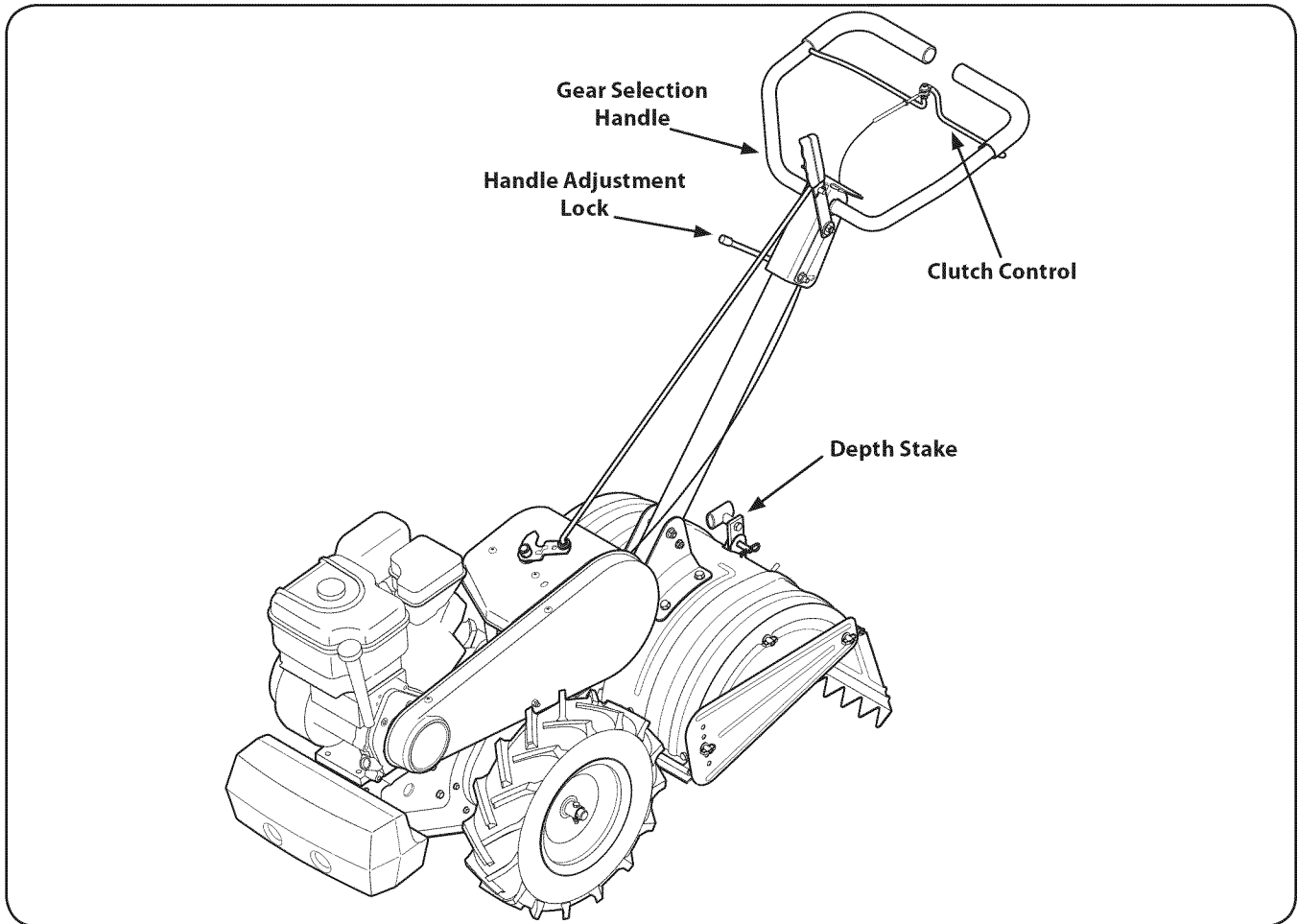

Figure 4-1

Engine Controls

See the separate Engine Operator's Manual for additional information and functions of the engine controls.

Gear Selection Handle

The gear selection handle is located on the front of the handle assembly. It is used to select NEUTRAL, REVERSE, or one of the FORWARD modes.

Clutch Control

The clutch control is located beneath the handle. Squeezing the clutch handle against the handle engages the wheel and tine drive mechanisms.

Throttle Control

The throttle control lever is located on the engine. It controls the engine speed and stops the engine.

Depth Stake

The depth stake controls the tilling depth.

Choke Lever (If equipped)

The choke lever is used to enrich the fuel mixture in the carburetor when starting a cold engine.

Primer (If equipped)

The primer is used when starting a cold engine.

Handle Adjustment Lock

The handle may be adjusted to the height desired by unlocking the Handle Adjustment Lock, then moving the handle bars to the desired position and then re-locking the Handle Adjustment Lock.

Fuel Shut-Off Valve (If equipped)

Make sure the valve is in the ON (horizontal) position when starting the engine. Any time the tiller is not in operation (i.e., storing, performing maintenance or adjustment), make sure the valve is in the OFF (vertical) position.

Starting the Engine



WARNING! Read, understand, and follow all the instructions and warnings on the machine and in this manual before operating.

NOTE: When pushing the machine with the engine off, you will hear a ratcheting-gear sound coming from the tiller's chain case. This is normal.



WARNING! Be sure that no one is standing in front of the tiller while the engine is running or being started.

1. Place the gear selection lever in NEUTRAL.
 2. Place the throttle control lever in the FAST position or — if equipped — place the engine speed control in the START position.
 3. Move the choke lever to the CHOKE position or — if equipped — push the primer two (2) or three (3) times. Wait about two (2) seconds between each push.
- NOTE:** A warm engine may not require choking or priming.
4. Stand at the side of the tiller. Grasp the starter handle and pull out slowly, until it pulls slightly harder. Let the rope recoil slowly.
 5. Pull the starter handle rapidly. Do not allow the handle to snap back. Allow it to recoil slowly while keeping a firm hold on the starter handle.
 6. Repeat the previous steps until the engine starts.
 7. As the engine warms up and begins to operate evenly, move the choke lever gradually to the RUN position. If the engine falters, return to the choke position, then slowly move to the RUN position.

NOTE: See the Engine Operator's Manual packed with your tiller for more detailed instructions.

Stopping the Engine

To stop the engine, move the throttle control to the STOP or OFF position. Disconnect the spark plug wire and ground it to prevent accidental starting while the equipment is unattended.

Setting the Depth

Tilling depth is controlled by the depth stake which can be adjusted to five different settings. Adjust the side shields as you adjust the depth stake.



WARNING! Always disconnect the spark plug wire and ground it against the engine before performing any adjustments.

1. When using the tiller for the first time, use the second adjustment hole from the top (1" of tilling depth). See Figure 5-1.

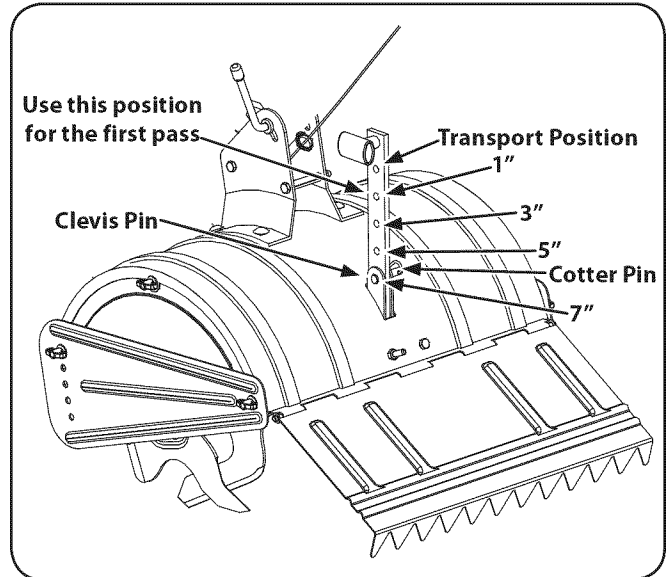

Figure 5-1

2. When breaking up sod and for shallow cultivation, use the setting which gives 1" of tilling depth (second hole from the top). Place the side shields in their lowest position.
3. For further depth, raise the depth stake and side shields and also make one or two more passes over the area.
4. When tilling loose soil, the depth stake may be raised to its highest position (use the bottom adjustment hole) to give the deepest tilling depth. Raise the side shields to their highest position.
5. To transport the tiller, lower the depth stake by using the top adjustment hole.
6. To adjust the depth stake, remove the clevis pin and hairpin clip. Move the depth stake to the desired setting and secure with the clevis pin and hairpin clip. See Figure 5-1.

- To adjust the side shields, remove the wing nuts. Move the side shield to the desired position and replace the wing nuts. Tighten securely. See Fig. 5-2.

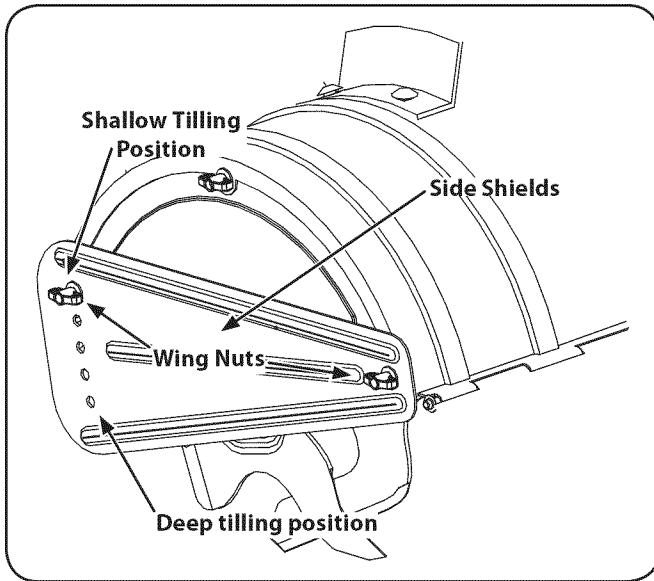

Figure 5-2

- For further depth, raise the depth stake and side shields and also make one or two more passes over the area.
- When tilling loose soil, the depth stake may be raised to its highest position by using the bottom adjustment hole to give the deepest tilling depth. Raise the side shields to the highest position.
- To transport the tiller, lower the depth stake by using the top adjustment hole.

Operating the Tiller

- Select the depth stake setting.
- Start the engine as instructed in the Engine Operator's Manual.
- Move the gear selection handle to one of the forward modes or reverse.



WARNING! Do not move the gear selection handle with the wheels or tines engaged. Make certain the tiller is stopped completely before changing the gear selection. A partial engagement may be necessary when engaging the tines.

NOTE: Use the reverse tine drive when tilling virgin ground, sod or hard soil. Use the forward tine drive when cultivating or tilling soft ground.

- Squeeze the clutch handle against the handle to engage the wheels and tines.

NOTE: Make certain the gear selection indicator is correctly positioned before engaging the clutch handle. If it is between gears, the engine will stall.
- To transport the tiller, do not engage the tines. Select the wheel drive only.



WARNING! Do not push down on the handles so that the wheels are lifted off the ground while using the tine drive, or the tiller could move backward and cause personal injury.

- For best results, it is recommended the garden be tilled twice (lengthwise, then widthwise) to thoroughly pulverize the soil.



WARNING! Disconnect the spark plug wire and ground it against the engine before performing any maintenance or repairs.

Maintenance

Engine

Refer to the separate Engine Operator's Manual for engine maintenance instructions.

Tires

Recommended operating tire pressure is approximately 14 p.s.i. on 14 inch tires and 20 p.s.i. on 16 inch tires. (Check the sidewall of the tire for the manufacturer's recommended pressure). Maximum tire pressure under any circumstances is 30 p.s.i. Equal tire pressure should be maintained on both tires.



WARNING! Excessive pressure (over 30 p.s.i.) when seating beads may cause the tire/rim assembly to burst with force sufficient to cause serious injury.

Air Cleaner

Service the air cleaner every 10 hours under normal conditions. Clean it every hour under extremely dusty conditions. Poor engine performance or flooding usually indicates that the air cleaner should be serviced. Refer to the Engine Operator's Manual for maintenance instructions.

Spark Plug

The spark plug should be cleaned and the gap reset every 25 hours of engine operation. Spark plug replacement is recommended at the start of each tiller season; check the Engine Operator's Manual for the correct plug type and gap specification.

Lubrication

Transmission

The transmission is pre-lubricated and sealed at the factory. It requires no checking unless the transmission is disassembled. To fill with grease, lay the right half of the transmission on its side, add 22 ounces of Benalene 920 grease, and assemble the left half to it. This grease can be obtained at your nearest authorized dealer by ordering part number 737-0300 or calling the Customer Support number on page 2.

Clutch Handle

Lubricate the pivot point on the clutch handle and the cable at least once a season with light oil. The control must operate freely in both directions.

Pivot Points

Lubricate all the pivot points and linkages at least once a season with light oil.

Tine Shafts

Remove the tine assemblies and lubricate the tine shafts at least once a season.

Wheel Shafts

Remove the wheel assemblies and lubricate the axle shafts at least once a season.

Adjustments



WARNING! Never attempt to make any adjustments while the engine is running, except where specified in the Operator's Manual.

Engine Adjustment

Refer to the separate Engine Operator's Manual for engine adjustment instructions.

Handle Adjustment

The handle may be adjusted to the desired height. Refer to the Controls & Features Section for details.

Belt Tension Adjustment

Periodic adjustment of the belt tension may be required due to normal stretch and wear on the belt. Adjustment is needed if the tines or wheels seem to hesitate while turning, but the engine maintains the same speed. To adjust the tension on the belt, refer to the Assembly & Set-Up Section for instructions.

Idler Pulley Rod

After the belt tension has been adjusted, if the belt is excessively stretched, you may need to adjust the idler pulley rod. This can be checked easily.

With the engine off and the clutch control bail disengaged, shift the gear selection handle to each forward mode. If the indicator bracket touches the idler pulley rod with the clutch control bail disengaged, then an adjustment is necessary.

1. Disconnect and ground the spark plug wire against the engine.
2. Remove the belt cover as described under Belt Replacement in the Service section.
3. Remove the hairpin clip and spring washer from the idler pulley rod. See Fig. 6-1.

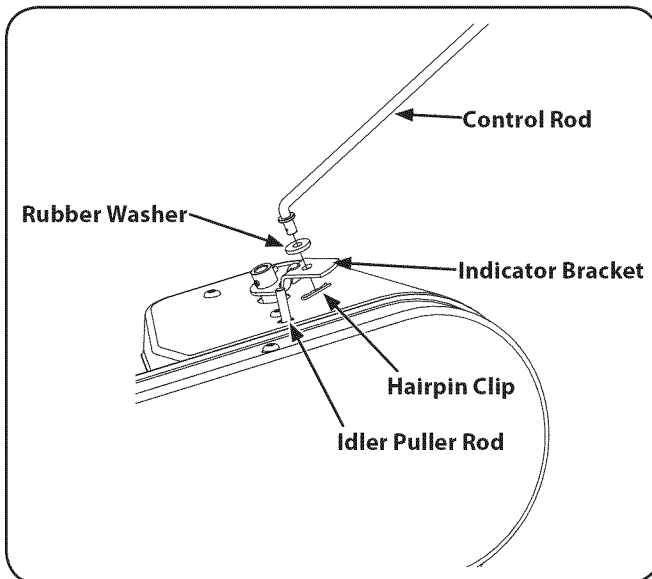

Figure 6-1

4. Move the idler pulley rod to the lower hole in the idler bracket.
5. Replace the spring washer and hairpin clip.
6. Check the clearance of the idler pulley rod to the indicator bracket by shifting to each forward mode.

Maintenance Schedule

	First 5 Hours	Each Use or Every 5 Hrs.	Every Season or 25 Hours	Every Season or 50 Hours	Every Season or 100 Hours	Service Dates
Check Engine Oil Level		✓				
Change Engine Oil	✓			✓		
Check Air Cleaner		✓				
Service Air Cleaner					✓	
Check Spark Plug			✓			
Replace Spark Plug					✓	
Clean around muffler		✓				

Periodic inspection and adjustment of the engine is essential if high level performance is to be maintained. Regular maintenance will also ensure a long service life. The required service intervals and the kind of maintenance to be performed are described in the table above. Follow the hourly or calendar intervals, whichever occur first. More frequent service is required when operating in adverse conditions.



WARNING! Shut off the engine before performing any maintenance. To prevent accidental start-up, disconnect the spark plug boot.

NOTE: If engine must be tipped to transport equipment or to inspect or remove grass, keep spark plug side of engine up. Transporting or tipping engine spark plug down may cause smoking, hard starting, spark plug fouling, or oil saturation of air cleaner.



WARNING! If the engine has been running, the muffler will be very hot. Be careful not to touch the muffler.

Oil

NOTE: Check the oil level before each use and after every five hours of operation to be sure correct oil level is maintained.

- Check oil level regularly.
- See the Assembly & Set-Up Section for instructions on how to properly check the oil.

Changing the Oil

NOTE: Be sure to check engine on a level surface with the engine stopped. Drain the oil while the engine is still warm to assure rapid and complete draining.

1. Drain fuel from tank by running engine until the fuel tank is empty. Be sure fuel fill cap is secure.
2. Remove drain plug and allow oil to drain into a suitable container. See Fig. 6-1.



WARNING! Before tipping engine or equipment to drain oil, drain fuel from tank by running engine until fuel tank is empty.

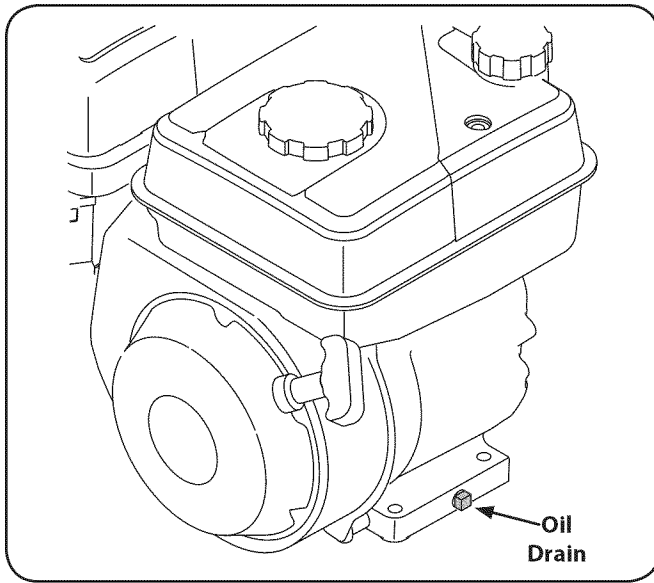

Figure 6-1

3. Reinstall the drain plug and tighten it securely.
4. Refill with the recommended oil and check the oil level. Refer to the Assembly & Set-up section for instructions on how to properly check the oil level.
5. Reinstall the oil fill cap securely.



WARNING! Used motor oil may cause skin cancer if repeatedly left in contact with the skin for prolonged periods. Although this is unlikely unless you handle used oil on a daily basis, it is still advisable to thoroughly wash your hands with soap and water as soon as possible after handling used oil.

NOTE: Please dispose of used motor oil in a manner that is compatible with the environment. We suggest you take it in a sealed container to your local service station for reclamation. Do not throw it in the trash or pour it on the ground.

Oil Recommendations

SAE 10W-30 is recommended for general, all temperature use. When adding oil to the engine, refer to the viscosity chart shown on this page. Engine oil capacity is 600 ml (approximately 20 oz.). Do not over-fill. Use a 4-stroke, or an equivalent high detergent, premium quality motor oil certified to meet or exceed U.S. automobile manufacturer's requirements for service classification SG, SF. Motor oils classified SG, SF will show this designation on the container.

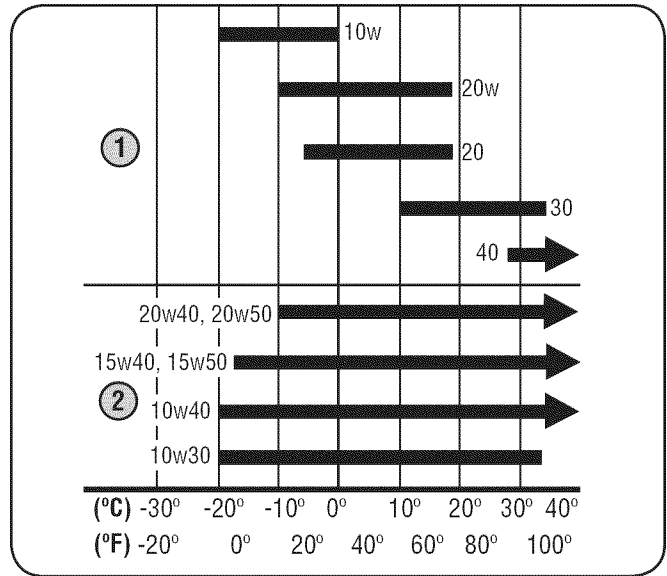

Ambient Temperature

1. Single Viscosity
2. Multi Viscosity



CAUTION! DO NOT use non-detergent oil or 2-stroke engine oil. It could shorten the engine's service life.

Air Filter

Paper filters cannot be cleaned and must be replaced once a year or every 100 operating hours; more often if used in extremely dusty conditions.



WARNING! Never use gasoline or low flash point solvents for cleaning the air cleaner element. A fire or explosion could result.

NOTE: Never run the engine without the air cleaner. Rapid engine wear will result.

1. Press the tab on the air filter cover and lift the cover. See Fig. 6-2. Replace paper element when dirty or damaged. Clean foam element or replace when damaged.

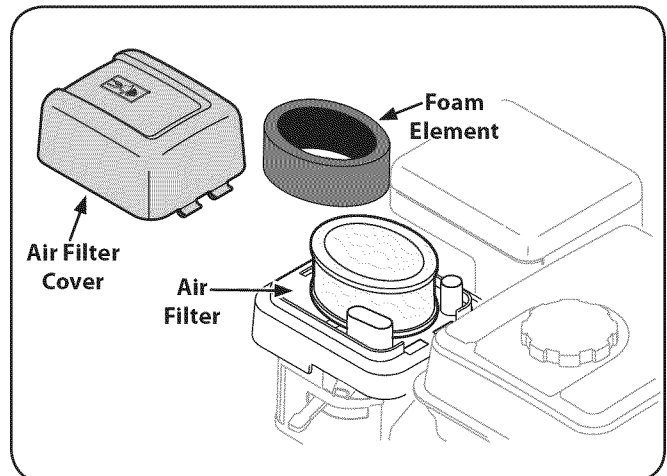

Figure 6-2

- To clean foam element, separate it from the paper element and wash in liquid detergent and water. Allow to dry thoroughly before using. Do not oil the foam element.

Spark Plug Service



WARNING! DO NOT check for spark with spark plug removed. DO NOT crank engine with spark plug removed.



WARNING! If the engine has been running, the muffler will be very hot. Be careful not to touch the muffler.

To ensure proper engine operation, the spark plug must be properly gapped and free of deposits.

- Remove the spark plug boot and use a spark plug wrench to remove the plug. See Fig. 6-3.

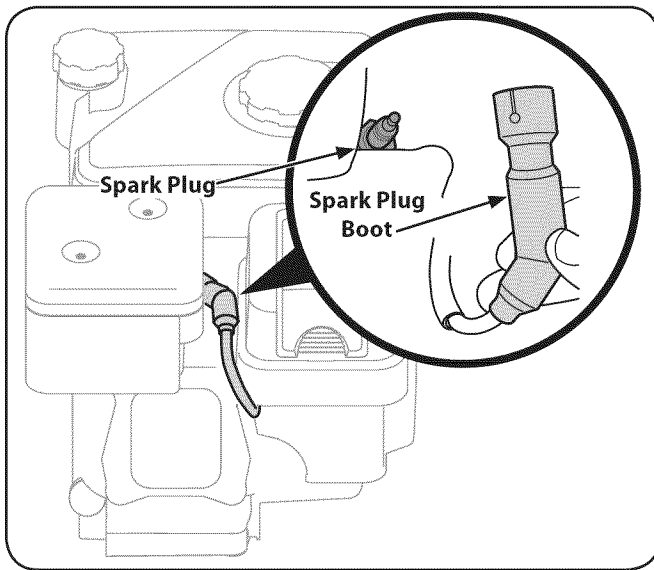

Figure 6-3

- Visually inspect the spark plug. Discard the spark plug if there is apparent wear, or if the insulator is cracked or chipped. Clean the spark plug with a wire brush if it is to be reused.
- Measure the plug gap with a feeler gauge. Correct as necessary by bending side electrode. See Fig. 6-4. The gap should be set to 0.030 in.

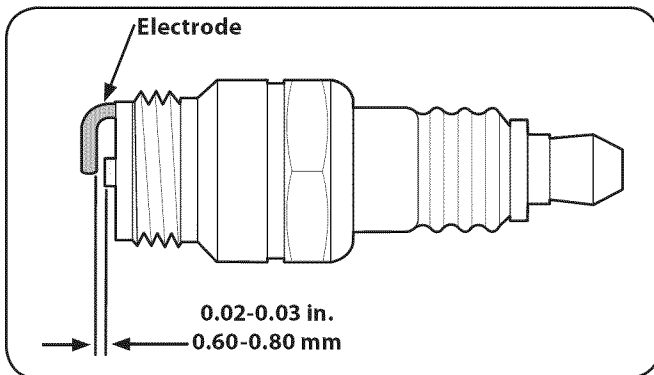

Figure 6-4

- Check that the spark plug washer is in good condition and thread the spark plug in by hand to prevent cross-threading.
- After the spark plug is seated, tighten with a spark plug wrench to compress the washer.

NOTE: When installing a new spark plug, tighten $\frac{1}{2}$ turn after the spark plug seats to compress the washer. When reinstalling a used spark plug, tighten $\frac{1}{8}$ - $\frac{1}{4}$ turn after the spark plug seats to compress the washer.



CAUTION! The spark plug must be securely tightened. An improperly tightened spark plug can become very hot and may damage the engine.

Cleaning the Engine

If the engine has been running, allow it to cool for at least half an hour before cleaning. Periodically remove dirt build-up from the engine. Clean around the muffler. Clean with a brush or compressed air.



CAUTION! Do not spray engine with water to clean because water could contaminate fuel. Using a garden hose or pressure washing equipment can also force water into the muffler opening. Water that passes through the muffler can enter the cylinder, causing damage.



WARNING! Accumulation of debris around muffler could cause a fire. Inspect and clean before every use.

Off-Season Storage

Engines stored between 30 and 90 days need to be treated with a gasoline stabilizer and engines stored over 90 days need to be drained of fuel to prevent deterioration and gum from forming in fuel system or on essential carburetor parts. If the gasoline in your engine deteriorates during storage, you may need to have the carburetor, and other fuel system components, serviced or replaced.

1. Remove all fuel from tank by running engine until it stops from lack of fuel.



WARNING! Never leave engine unattended while it is running.

2. Change the oil. See Changing the Oil earlier in this section.
3. Remove spark plug and pour about a ½ ounce of engine oil into the cylinder. Replace spark plug and crank it slowly to distribute oil.
4. Clean debris from around the engine and the muffler. Touch up any damaged paint, and coat other areas that may rust with a light film of oil.
5. Store in a clean, dry and well ventilated area away from any appliance that operates with a flame or pilot light, such as a furnace, water heater, or clothes dryer. Also avoid any area with a spark producing electric motor, or where power tools are operated.
6. If possible, also avoid storage areas with high humidity, because that promotes rust and corrosion.
7. Keep the engine level in storage. Tilting can cause fuel or oil leakage.

Belt Replacement

Your tiller has been engineered with a belt designed for long life and optimal performance. It should never be replaced with a non-OEM belt. Order all belts through an authorized service dealer or by contacting Customer Support as instructed on page 2.

Refer to Fig. 7-1 for the following steps.

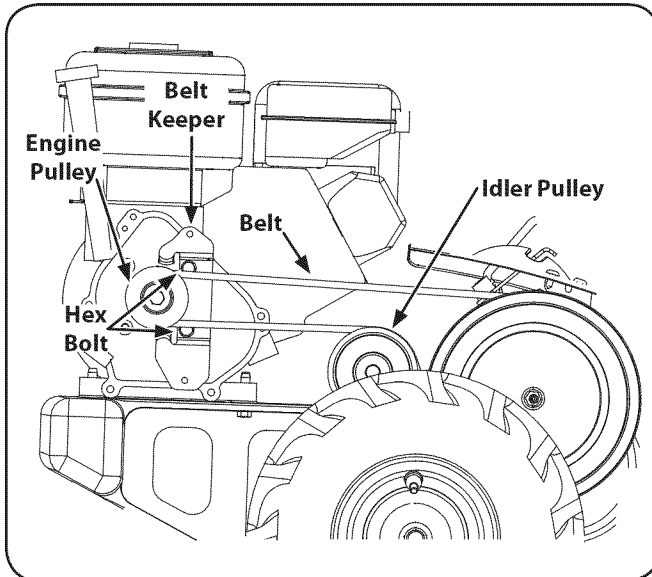

Figure 7-1

1. Disconnect and ground the spark plug wire against the engine.
2. Remove the belt cover from the left side of the tiller by removing the two hex head screws from the top of the belt cover.
3. Remove the two hex cap nuts and flat washers from the front side of the belt cover. Remove the hex nut and flat washer at the back of the cover.
4. Remove the belt keeper assembly located behind the engine pulley by removing the two hex bolts and lock washers.
5. Remove the old belt and install the new belt. Follow the instructions in reverse order to re-install the belt keeper and belt cover.

NOTE: Upon reassembly, make certain the belt is routed over the idler pulley and inside of belt keepers by the engine pulley. See

Fig. 7-1.



Off-Season Storage

If the tiller will not be used for a period longer than 30 days, the following steps should be taken to prepare the tiller for storage.

- Clean the exterior of the engine and the entire tiller thoroughly. Lubricate the tiller as described in the Lubrication instructions.
- Using a pressure washer to clean your tiller is not recommended. The washer may cause damage to the electric components, spindles, pulleys, bearings or the engine. Using a pressure washers will result in shortened life and reduce serviceability.
- Refer to the Engine Operator's Manual for the correct engine storage instructions.
- Wipe the tines with an oiled rag to prevent rust.
- Store the tiller in a clean, dry area. Do not store next to corrosive materials, such as fertilizer.

NOTE: When storing any type of power equipment in an unventilated area or metal storage shed, care should be taken to rustproof the equipment. Using a light oil or silicone, coat the equipment and especially any springs, bearings, and cables.

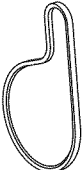
Problem	Cause	Remedy
Engine fails to start	<ol style="list-style-type: none"> 1. Fuel tank empty or stale fuel. 2. Throttle control lever not in correct starting position (if equipped). 3. Blocked fuel line. 4. Dirty air cleaner. 5. Choke not in ON position. 6. Spark plug wire disconnected. 7. Faulty spark plug. 8. Engine flooded. 	<ol style="list-style-type: none"> 1. Fill tank with clean, fresh gasoline. 2. Move throttle lever to start position. 3. Clean fuel line. 4. Refer to the Engine Operator's Manual 5. Move switch to ON position. 6. Connect wire to spark plug. 7. Clean, adjust gap or replace. 8. Refer to the Engine Operator's Manual
Engine runs erratic	<ol style="list-style-type: none"> 1. Tiller running on CHOKE. 2. Spark plug wire loose. 3. Blocked fuel line or stale fuel. 4. Vent in gas cap plugged. 5. Water or dirt in fuel system. 6. Dirty air cleaner. 7. Carburetor out of adjustment. 	<ol style="list-style-type: none"> 1. Move choke lever to OFF position. 2. Connect and tighten spark plug wire. 3. Clean fuel line; fill tank with clean, fresh gasoline. 4. Clear vent. 5. Drain fuel tank. Refill with fresh fuel. 6. Refer to the Engine Operator's Manual 7. Refer to the Engine Operator's Manual
Engine overheats	<ol style="list-style-type: none"> 1. Engine oil level low. 2. Dirty air cleaner. 3. Air flow restricted. 4. Carburetor not adjusted properly. 	<ol style="list-style-type: none"> 1. Fill crankcase with proper oil. 2. Refer to the Engine Operator's Manual 3. Refer to the Engine Operator's Manual 4. Adjust carburetor as instructed in the Engine Operator's Manual
Tines do not engage	<ol style="list-style-type: none"> 1. Foreign object lodged in tines. 2. Tine clevis pin(s) missing. 3. Pulley and idler not in correct adjustment. 4. Not shifting properly. 5. Control cable not adjusted properly. 6. Belt worn and/or stretched. 	<ol style="list-style-type: none"> 1. Dislodge foreign object. 2. Replace tine clevis pin(s). 3. Take tiller to authorized service dealer. 4. Refer to the Operation Section for proper shifting procedures. 5. Adjust control cable 6. Replace belt.
Tines skip over ground	<ol style="list-style-type: none"> 1. Improper rotation. 	<ol style="list-style-type: none"> 1. Forward rotation should only be used on soil that has already been tilled, not on virgin soil.
Wheels do not engage	<ol style="list-style-type: none"> 1. Clevis pin missing. 2. Tiller is not being shifted properly. 3. Control cable not adjusted properly. 4. Belt worn and/or stretched. 	<ol style="list-style-type: none"> 1. Replace clevis pin. 2. Refer to Operation Section for proper shifting procedures. 3. Adjust control cable 4. Replace belt.

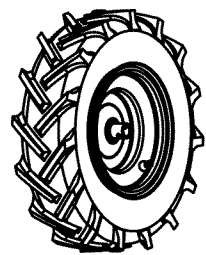
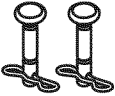
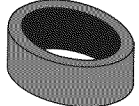
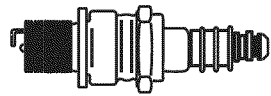
Component	Part Number and Description
	954-0434 Belt, 4L x 58.16
	742-0305A Articulating Tine
	746-1117 Clutch Cable
	934-04233 Tires, 14 x 4.5 x 6
	714-04043 Cotter Pin, Tine Assembly 911-0415 Clevis Pin, Tine Assembly 714-0147 Cotter Pin, Depth Stake 911-0415 Clevis Pin, Depth Stake
	951-10794 Air Filter
	951-10292 Spark plug

Phone (800) 800-7310 or (330) 220-4683 to order replacement parts or a complete Parts Manual (have your full model number and serial number ready). Parts Manual downloads are also available free of charge at www.mtdproducts.com.

MANUFACTURER'S LIMITED WARRANTY FOR



The limited warranty set forth below is given by MTD LLC with respect to new merchandise purchased and used in the United States and/or its territories and possessions, and by MTD Products Limited with respect to new merchandise purchased and used in Canada and/or its territories and possessions (either entity respectively, "MTD").

"MTD" warrants this product (excluding its *Normal Wear Parts and Attachments* as described below) against defects in material and workmanship for a period of two (2) years commencing on the date of original purchase and will, at its option, repair or replace, free of charge, any part found to be defective in materials or workmanship. This limited warranty shall only apply if this product has been operated and maintained in accordance with the Operator's Manual furnished with the product, and has not been subject to misuse, abuse, commercial use, neglect, accident, improper maintenance, alteration, vandalism, theft, fire, water, or damage because of other peril or natural disaster. Damage resulting from the installation or use of any part, accessory or attachment not approved by MTD for use with the product(s) covered by this manual will void your warranty as to any resulting damage.

Normal Wear Parts are warranted to be free from defects in material and workmanship for a period of thirty (30) days from the date of purchase. Normal wear parts include, but are not limited to items such as: batteries, belts, blades, blade adapters, tines, grass bags, wheels, rider deck wheels, seats, snow thrower skid shoes, friction wheels, shave plates, auger spiral rubber, engine oil, air filters, spark plugs and tires.

Attachments — MTD warrants attachments for this product against defects in material and workmanship for a period of one (1) year, commencing on the date of the attachment's original purchase or lease. Attachments include, but are not limited to items such as: grass collectors and mulch kits.

HOW TO OBTAIN SERVICE: Warranty service is available, WITH PROOF OF PURCHASE, through your local authorized service dealer. To locate the dealer in your area:

In the U.S.A.

Check your Yellow Pages, or contact MTD LLC at P.O. Box 361131, Cleveland, Ohio 44136-0019, or call 1-800-800-7310, 1-330-220-4683 or log on to our Web site at www.mtdproducts.com.

In Canada

Contact MTD Products Limited, Kitchener, ON N2G 4J1, or call 1-800-668-1238 or log on to our Web site at www.mtdcanada.com.

This limited warranty does **not** provide coverage in the following cases:

- a. Log splitter pumps, valves, and cylinders have a separate one-year warranty.
- b. Routine maintenance items such as lubricants, filters, blade sharpening, tune-ups, brake adjustments, clutch adjustments, deck adjustments, and normal deterioration of the exterior finish due to use or exposure.

- c. Service completed by someone other than an authorized service dealer.
- d. MTD does not extend any warranty for products sold or exported outside of the United States and/or Canada, and their respective possessions and territories, except those sold through MTD's authorized channels of export distribution.
- e. Replacement parts that are not genuine MTD parts.
- f. Transportation charges and service calls.
- g. MTD does not warrant this product for commercial use.

No implied warranty, including any implied warranty of merchantability of fitness for a particular purpose, applies after the applicable period of express written warranty above as to the parts as identified. No other express warranty, whether written or oral, except as mentioned above, given by any person or entity, including a dealer or retailer, with respect to any product, shall bind MTD. During the period of the warranty, the exclusive remedy is repair or replacement of the product as set forth above.

The provisions as set forth in this warranty provide the sole and exclusive remedy arising from the sale. MTD shall not be liable for incidental or consequential loss or damage including, without limitation, expenses incurred for substitute or replacement lawn care services or for rental expenses to temporarily replace a warranted product.

Some states do not allow the exclusion or limitation of incidental or consequential damages, or limitations on how long an implied warranty lasts, so the above exclusions or limitations may not apply to you.

In no event shall recovery of any kind be greater than the amount of the purchase price of the product sold. **Alteration of safety features of the product shall void this warranty.** You assume the risk and liability for loss, damage, or injury to you and your property and/or to others and their property arising out of the misuse or inability to use the product.

This limited warranty shall not extend to anyone other than the original purchaser or to the person for whom it was purchased as a gift.

HOW STATE LAW RELATES TO THIS WARRANTY: This limited warranty gives you specific legal rights, and you may also have other rights which vary from state to state.

IMPORTANT: Owner must present Original Proof of Purchase to obtain warranty coverage.

**MTD LLC, P.O. BOX 361131 CLEVELAND, OHIO 44136-0019; Phone: 1-800-800-7310, 1-330-220-4683
MTD Canada Limited - KITCHENER, ON N2G 4J1; Phone 1-800-668-1238**