

ITEM# 1-1-32101

E
EASTPOINT

Springfield

*7.5 ft / 2.29 m BILLIARD TABLE
and CUE RACK*



Assembly Instructions
Model # 32101

www.eastpointsports.com

TWO OR MORE ADULTS REQUIRED FOR ASSEMBLY



IMPORTANT -

- Table components are stored in the bottom of the cabinet .
 - Remove carton containing lower aprons .
 - Replace carton top and turn table over.
- Note: Use at least 2 adults to pick up and flip table.
- Remove lower carton .

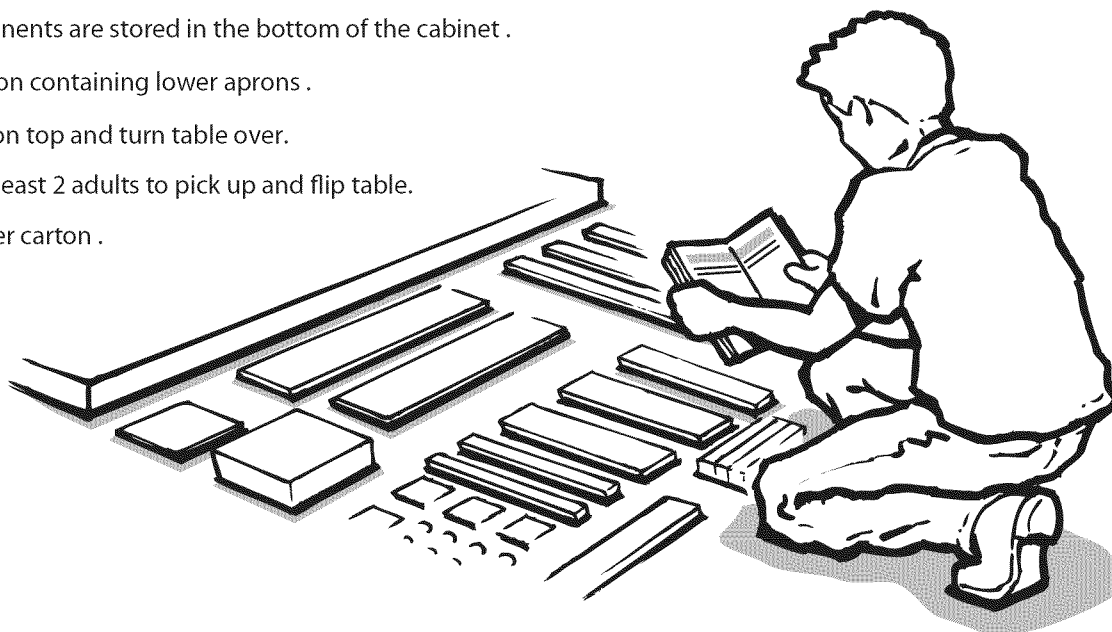

Lay out all parts before you begin

- Please review the parts identifier and make sure that you have all parts before beginning assembly.
- If any questions or issues, please contact us at 1-973-585-4747 **BEFORE** returning the product to the original place of purchase.
- Please keep your original sales receipt. Staple it on the adjacent page in the space provided for future reference/use. It will be required to receive service help or parts under warranty.

CONTACT INFO

Hours

Monday to Friday
(9:00am to 5pm EST)

Technical Support or Replacement Parts

Email us at: consumerservice@eastpointports.com
Visit us at: www.eastpointports.com
Call: 973-585-4747

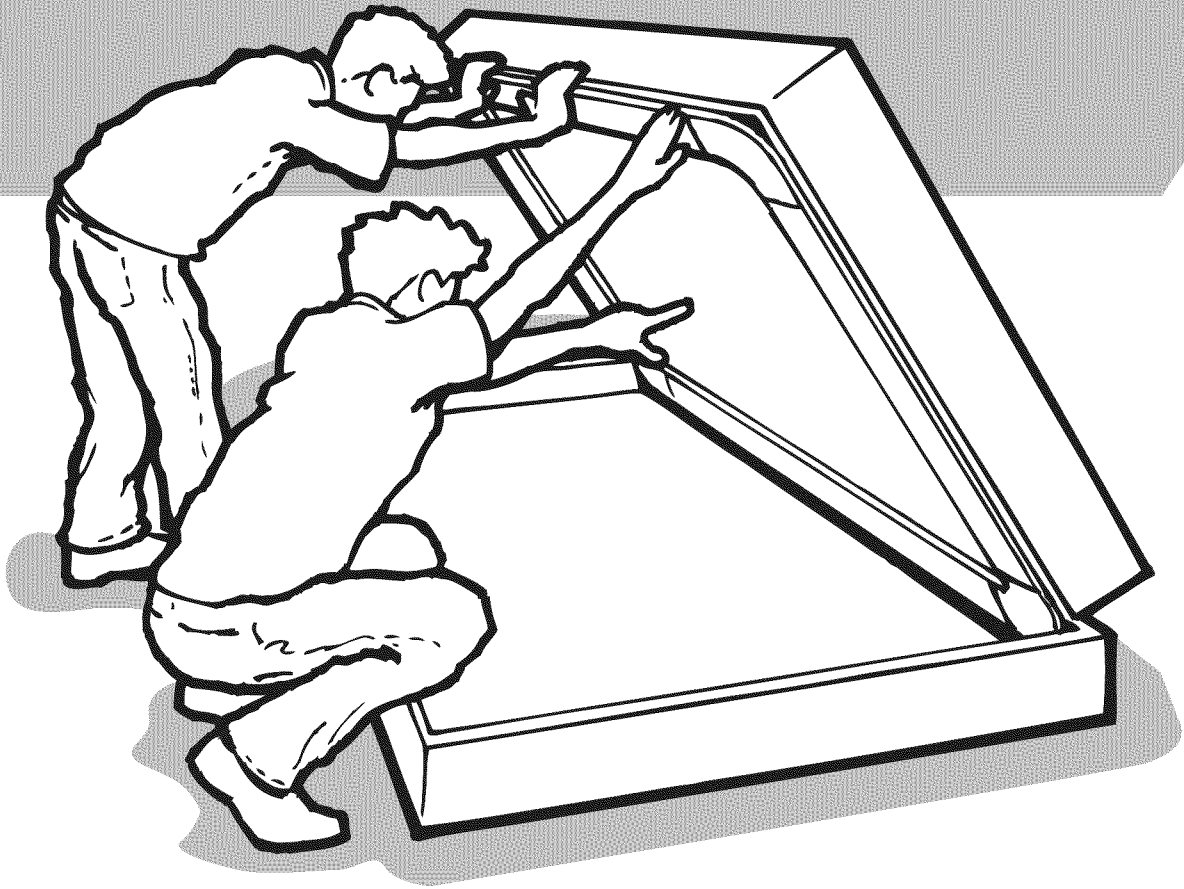

BEFORE BUILDING - Please inspect your playfield

Your Cabinet (Billiard table Playfield) is **NOT replaceable**. Any damage that exists to your playfield is not reparable under warranty. If your playfield is damaged, the entire game must be returned to the original place of purchase for an exchange.

**Please attach
RECEIPT HERE**

It will be required to receive service help or parts under warranty.

TOOLS Required

- 1 - Phillips Head Screwdriver
(Standard Size) – Not Included
- 1 - Flat Head Screwdriver
(Standard Size) – Not Included
- 1 - Wrench – Included

Recommended (Not Required):

- Electric Screwdriver or Power Driver
CAUTION – DO NOT OVER TIGHTEN. Over Tightening will result in irreparable damage to the product. If using, please make sure that the tool is set to a very low torque to prevent damage to the product.
- Socket Wrench Set
- Level

How to use the: PARTS IDENTIFIER

Before you begin assembly, please make sure that you have all the parts listed and in the correct quantities. This will ensure the quickest and most organized assembly.

Be sure to work on the assembly on a soft non-marring surface such as carpet or the inside of the corrugate box top to prevent causing damage to the table surface during assembly.

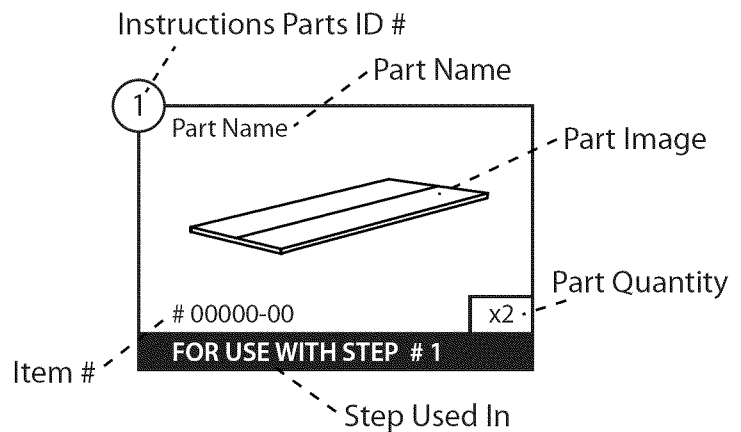

PARTS IDENTIFIER

Components

1 Leg Top Panel

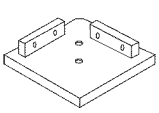

32101-01ES x4

STEP # 1

2 Leg Support



32101-02ES x4

STEP # 1

3 Plastic Leg - A



32101-03ES x4

FOR USE WITH STEP # 2

4 Plastic Leg - B



32101-04ES x4

FOR USE WITH STEP # 2

5 Plastic Leg - C



32101-05ES x4

FOR USE WITH STEP # 2

6 Plastic Leg - D



32101-06ES x4

FOR USE WITH STEP # 2

Components cont.

7 Connect Board

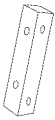

32101-07ES x4
FOR USE WITH STEP # 6

8 Lower Side Apron



32101-08ES x2
FOR USE WITH STEP # 6

9 Lower End Apron



32101-09ES x2
FOR USE WITH STEP # 6

10 Main Frame

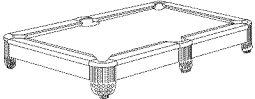

32101-10ES x1
FOR USE WITH STEP # 8

11 1mm Shim



32101-11ES x3
FOR USE WITH STEP # 10

12 2mm Shim



32101-12ES x3
FOR USE WITH STEP # 10

13 3mm Shim



32101-13ES x3
FOR USE WITH STEP # 10

14 Cue Rack - Left Side



32101-14ES x1
FOR USE WITH STEP # A

15 Cue Rack - Right Side



32101-15ES x1
FOR USE WITH STEP # A

16 Cue Rack - Middle Shelf



32101-16ES x2
FOR USE WITH STEP # A

17 Cue Rack - Top Panel

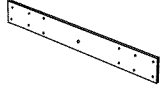

32101-17ES x1
FOR USE WITH STEP # B

18 Cue Rack - Base Panel

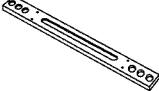

32101-18ES x1
FOR USE WITH STEP # B

19 Cue Rack Hook



32101-19ES x2
FOR USE WITH STEP # B

20 Cue Holder



32101-20ES x2
FOR USE WITH STEP # B

21 Triangle Holder



32101-21ES x1
FOR USE WITH STEP # B

Hardware

60 8 x76mm Hex Bolt

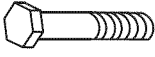

32101-60ES x8

STEP # 1

61 8x19mm Washer

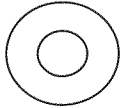

32101-61ES x64

STEP # 1, 6, 7, & 9

62 8mm- Barrel Nut



32101-62ES x8

STEP # 1

63 4 x 12mm Screw



32101-63ES x13

STEP # 3& B

64 3x12mm Screws



32101-64ES x16

STEP # 5

65 8x38mm Hex Bolt

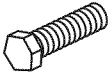

32101-65ES x44

STEP # 6, 7, & 9

66 8mm Hex Nut



32101-66ES x12

STEP # 9

67 4x44.5mm Flat Head Screw



37003-60ES x16

STEP # A & B

68 3x12mm Flat Head Screw



32101-68ES x4

STEP # B

69 Wrench



32101-69ES x1

STEP # 5, 6, 7, & 9

Accessories

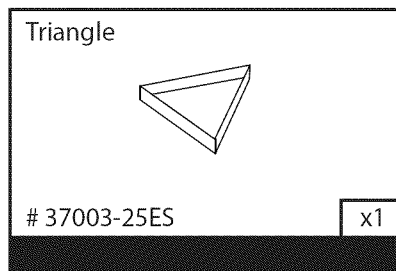
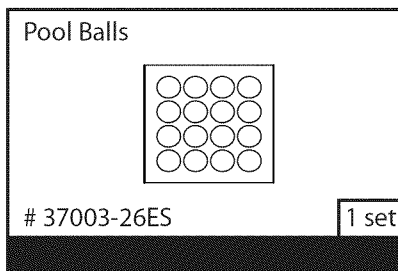
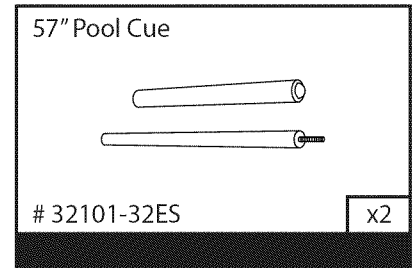
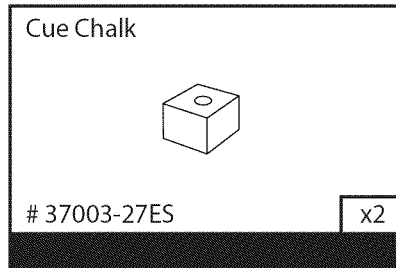
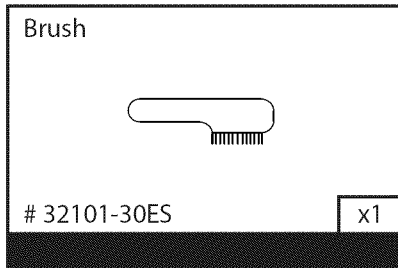

BILLIARD TABLE - INSTRUCTIONS

BEFORE

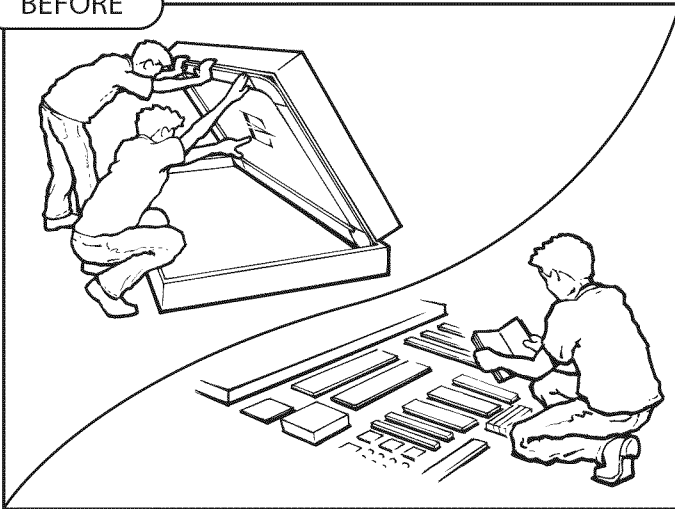

NOTE:

BEFORE BUILDING - Please inspect your playfield and layout all your parts

Your Cabinet (Billiard Table playfield) is NOT replaceable. Any damage that exists to your playfield is not reparable under warranty. If your playfield is damaged, the entire game must be returned to the original place of purchase for an exchange.

Visit www.eastpointsports.com to view video that shows how to assemble billiard table legs.

STEP 1

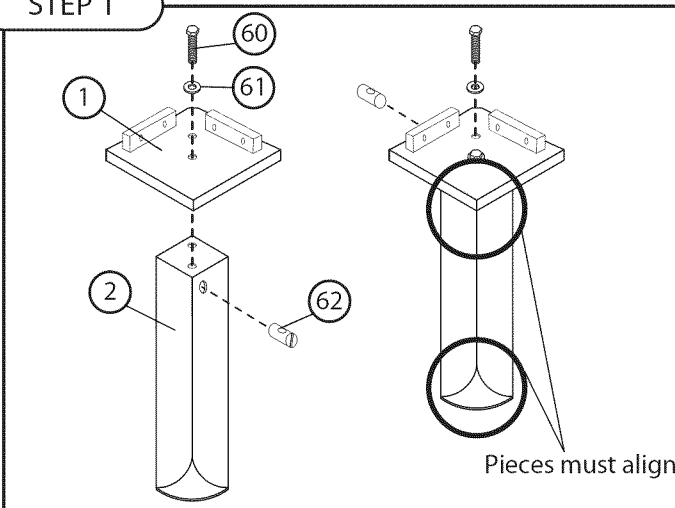

COMPONENTS

- ① Leg Top Panel
- ② Leg Support

QTY.

x4
x4

NOTE:

Repeat for all 4 legs.

NOTE: Finger tighten bolt (#60) only.

HARDWARE

- ⑥0 8x76mm Hex Bolt
- ⑥1 8x19mm Washer (use 8 of the 64)
- ⑥2 8mm - Barrel Nut

QTY.

x8
x8
x8

STEP 2

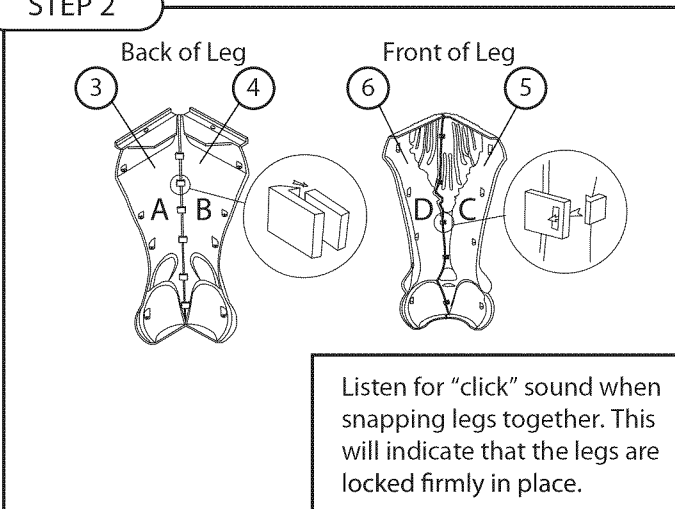

COMPONENTS

- ③ Plastic Leg - A
- ④ Plastic Leg - B
- ⑤ Plastic Leg - C
- ⑥ Plastic Leg - D

QTY.

x4
x4
x4
x4

NOTES

- Repeat for all 4 legs.
- Look for letters (A,B,C,D) on the inside of the leg panels.
- Make sure leg panels **Snap** and **Lock** together.

STEP 3

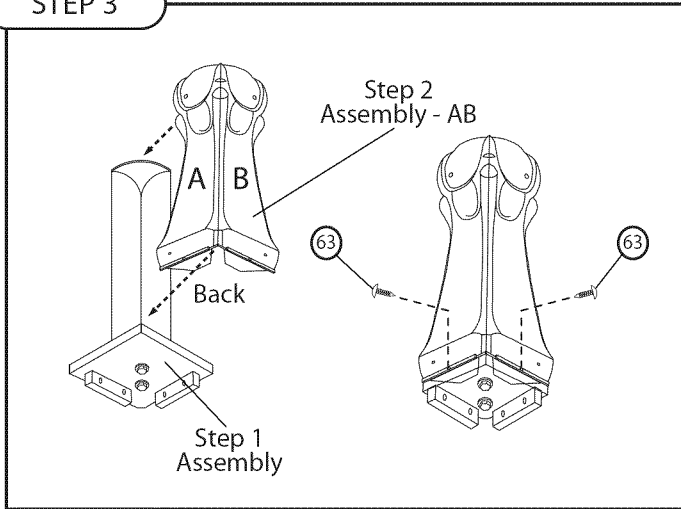

COMPONENTS	QTY.
Step 1 Assembly	x4
Step 2 Assembly - AB	x4
HARDWARE	
63 4x12mm Screw (use 8 of 13)	x8

NOTE:
Repeat for all four legs.
Do not overtighten screws.

STEP 4

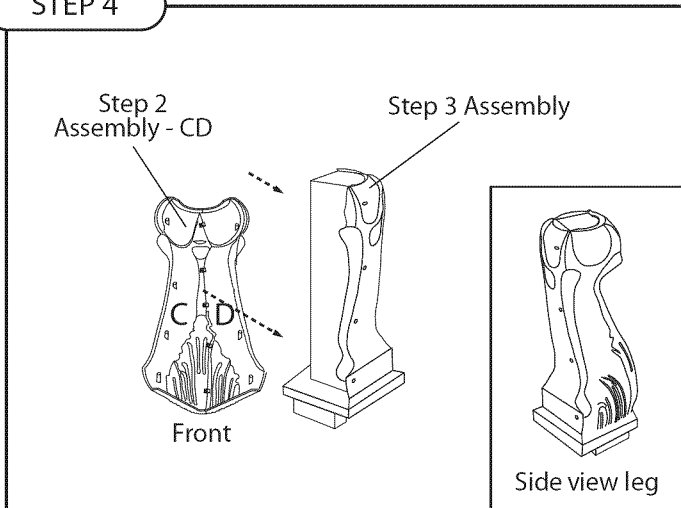

COMPONENTS	QTY.
Step 2 Assembly - CD	x4
Step 3 Assembly	x4

NOTE:
Repeat for all four legs.
Do not overtighten screws.

STEP 5

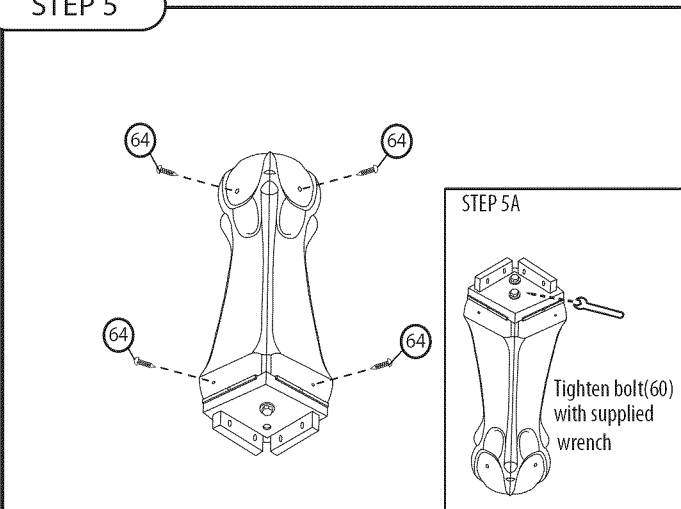

COMPONENTS	QTY.
Step 4 Assembly	x4
HARDWARE	
64 3x12mm Screws	x16

NOTES
Repeat for all four legs.
Do not overtighten screws.

STEP 6

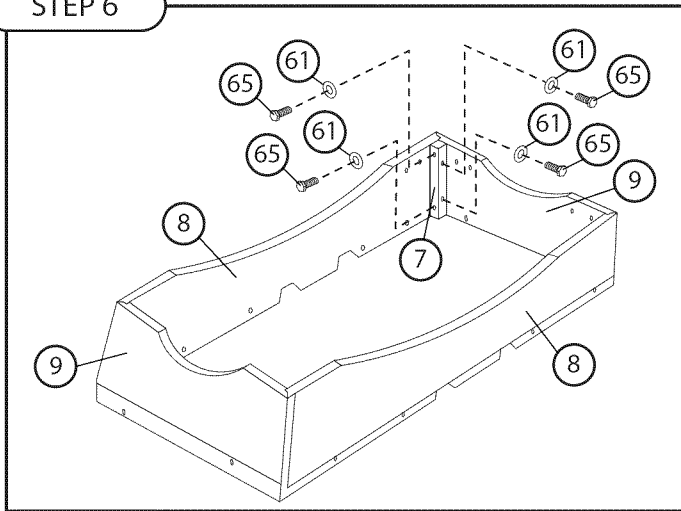

COMPONENTS

COMPONENTS	QTY.
7 Connect Board	x4
8 Lower Side Apron	x2
9 Lower End Apron	x2

HARDWARE

HARDWARE	QTY.
61 8x19mm Washer	x16
65 8x38mm Hex Bolt	x16

NOTE:

Repeat for all four corners.

STEP 7

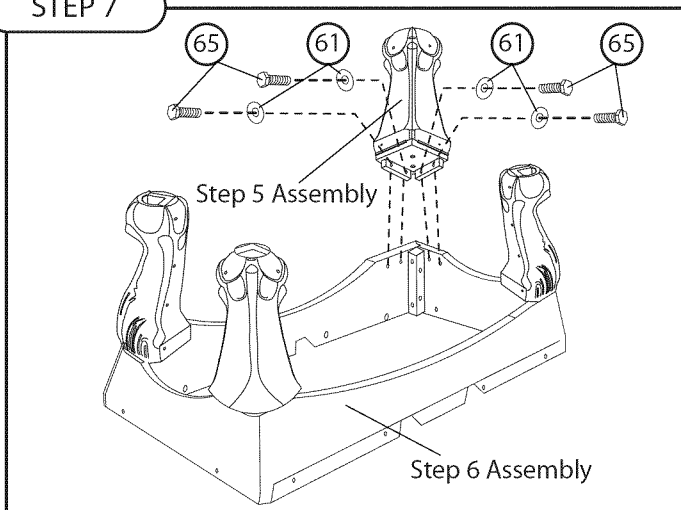

COMPONENTS

COMPONENTS	QTY.
Step 5 Assembly	x4
Step 6 Assembly	x1

HARDWARE

HARDWARE	QTY.
61 8x19mm Washer	x16
65 8x38mm Hex Bolt	x16

NOTE:

Repeat for all four legs.

Do not overtighten screws.

STEP 8

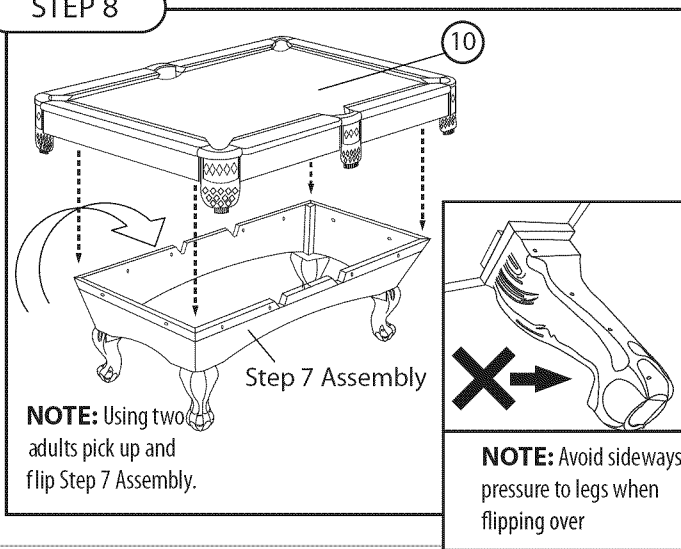

COMPONENTS

COMPONENTS	QTY.
10 Main Frame	x1
Step 7 Assembly	x1

NOTES

Using at least two adults pick up and flip Step 7 Assembly.

Pick table up flip over and place straight down.

NOTE: Avoid sideways pressure to legs

NOTE: Using two adults pick up and flip Step 7 Assembly.

NOTE: Avoid sideways pressure to legs when flipping over

STEP 9

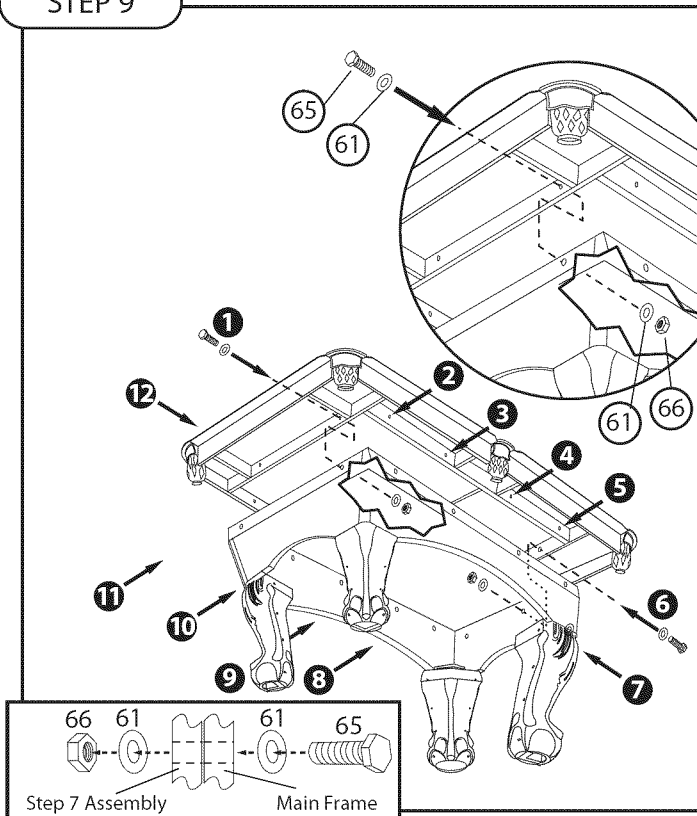

COMPONENTS

Step 8 Assembly x1

HARDWARE

61 8x19mm Washer x24
65 8x38mm Hex Bolt x12
66 8mm Hex Nut x12

NOTE:

STEP 10

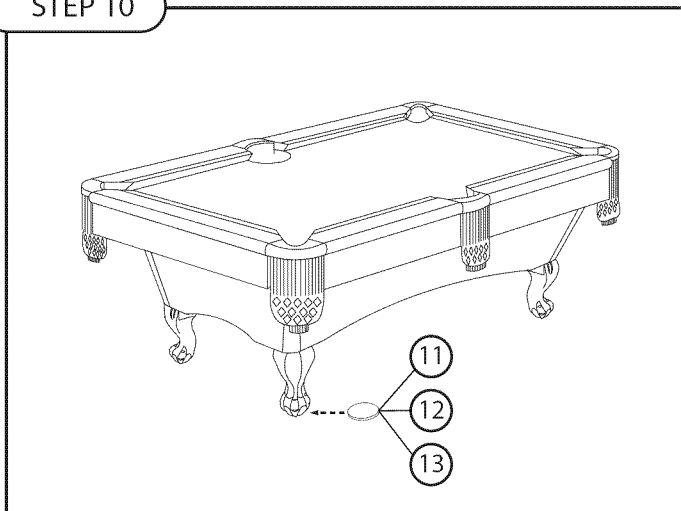

COMPONENTS

11 1mm Shim x3
12 2mm Shim x3
13 3mm Shim x3

Step 9 Assembly x1

NOTE:

Use the shims as needed under legs to level the table.

You will need a level to do this.

CUE RACK- INSTRUCTIONS

STEP A

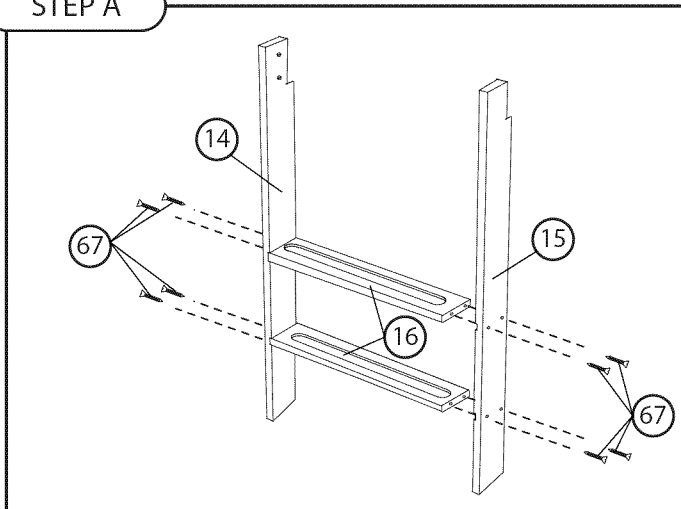

COMPONENTS	QTY.
(14) Cue Rack - Left Side	x1
(15) Cue Rack - Right Side	x1
(16) Cue Rack - Middle Shelf	x2

NOTE:

Do not over tighten screws.

HARDWARE	QTY.
(67) 4x44.5mm Flat Head Screw (8 of 16)	x8

STEP B

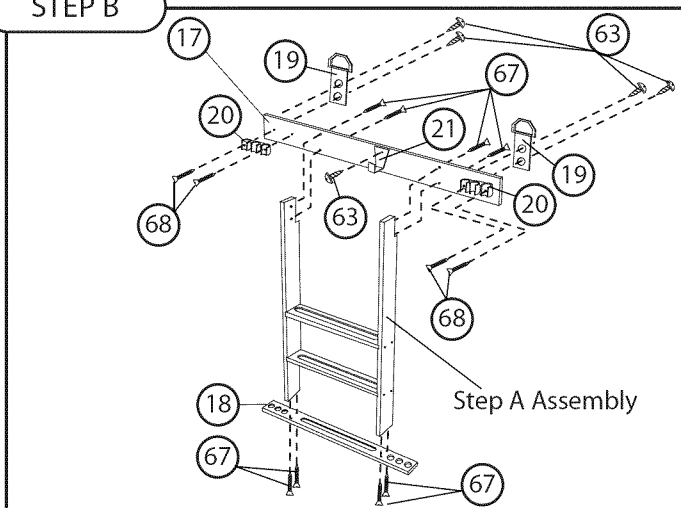

COMPONENTS	QTY.
(17) Cue Rack - Top Panel	x1
(18) Cue Rack - Base Panel	x1
(19) Cue Rack Hook	x2
(20) Cue Holder	x2
(21) Triangle Holder	x1
Step A Assembly	x1

NOTE:

HARDWARE	QTY.
(67) 4 x44.5mm Flat Head Screw (8 of 16)	x8
(68) 3x12mm Flat Head Screw	x4
(63) 4x12mm Screw	x5

STEP C

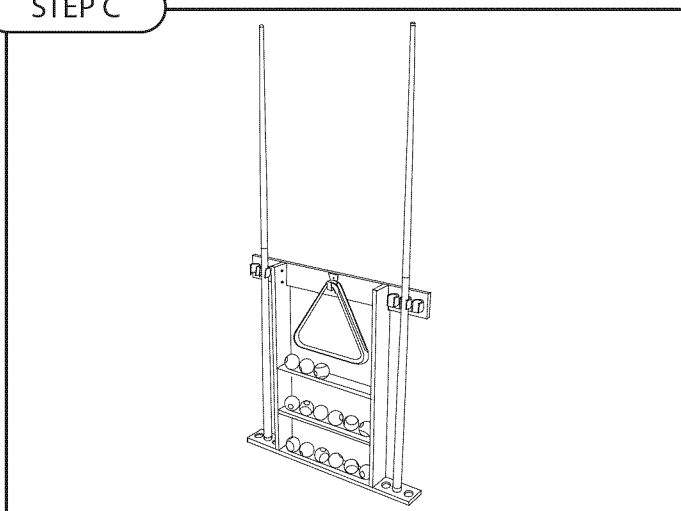

COMPONENTS	QTY.
------------	------

NOTES

Limited Warranty

As described in and as limited by this Limited Warranty, EastPoint Sports, Ltd. (the "Company") warrants this Billiard Table (the "Product") to be free from defects in workmanship and materials for a period of 90 days from the date of original purchase. The term defects shall mean any imperfections that impair the use of the product. The Company reserves the right to request confirmation of Proof of Purchase when requesting parts or service in order to confirm that the game is within its warranty period.

What is Covered: Except as provided herein, this Limited Warranty covers all defects in materials and workmanship. This Limited Warranty is void if the Product is:

- Damaged through improper usage or storage, negligence, misuse, abuse, transportation damage, acts of nature, or accident (including failure to follow the instructions supplied with the product)
- Used in commercial applications, rentals or a commercial environment
- Modified or repaired by anyone not authorized by the Company

What is Not Covered:

The Limited Warranty does not cover:

- Expendable items such as cosmetic parts, game playing accessories, and any other items that may show signs of wear due to normal usage
- Any transportation/delivery/installation costs incurred by the Consumer (either home from the original place of purchase or back to the original place of purchase)

What the Company Will Pay For:

- If any part or component of the Product which is covered by this Limited Warranty is found by the Company to be defective, the Company will provide replacement parts without charge. The Company's obligation to repair or replace the Product or any portion thereof, shall be limited to the original purchase price of the product.
- If during the Limited Warranty period, the product is found to be defective, the Company will, at the Company's option, send parts, or make remuneration for the Product (either the same or equivalent value) without charge.

How to Obtain Warranty Service: In order to enforce your rights under this Limited Warranty, you must follow these procedures:

- You must return the ORIGINAL COPY OF YOUR SALES RECEIPT to the Company.
- You must call the Company's Consumer Service Department at 1-877-279-7071 on Monday through Friday between the hours of 9:00 A.M. and 5:00 P.M. (EST) to notify the Company of the nature of the problem. At the Company's option, replacement parts or a new Product (either the same or equivalent value) will be sent to you at no charge.
- If you are instructed to return the Product to the Company for servicing, you are responsible for shipping the Product, at your expense, to the address designated by the Company in packaging that will protect against further damage.
- You must also include your name, address, daytime telephone number, Product model number, and a description of the problem.
- The Company will pay for any shipping charges to return the repaired or replaced Product to you.

THIS LIMITED WARRANTY IS AVAILABLE ONLY TO THE ORIGINAL PURCHASER OF THE PRODUCT AND IS VALID ONLY IN THE UNITED STATES. THE COMPANY'S LIABILITY IS LIMITED TO THE REPAIR, REPLACEMENT, OR REMUNERATION, AT ITS OPTION, OF ANY DEFECTIVE PRODUCT AND SHALL NOT INCLUDE ANY LIABILITY FOR INDIRECT, INCIDENTAL, OR CONSEQUENTIAL DAMAGES OF ANY KIND. THIS WARRANTY IS EXPRESSLY MADE IN LIEU OF ALL OTHER WARRANTIES, EXPRESSED OR IMPLIED, INCLUDING BUT NOT LIMITED TO THE IMPLIED WARRANTY OF MERCHANTABILITY AND THE IMPLIED WARRANTY OF FITNESS FOR A PARTICULAR PURPOSE. SOME STATES DO NOT ALLOW LIMITATIONS ON HOW LONG AN IMPLIED WARRANTY LASTS OR DO NOT ALLOW FOR EXCLUSION OF INCIDENTAL OR CONSEQUENTIAL DAMAGES. TO THAT EXTENT, THE ABOVE LIMITATIONS MAY NOT APPLY TO YOU.

This Limited Warranty gives you specific legal rights, but you may also have other rights that vary from state to state.

If you have any questions regarding this Limited Warranty or the operation of the Product, you may call or write us.

ALL WARRANTY CLAIMS MUST BE ACCOMPANIED BY A COPY OF THE SALES RECEIPT/PROOF OF PURCHASE. REPORT ANY DEFECTS TO:



628 ROUTE 10, SUITE #5 WHIPPANY, NEW JERSEY 07981 • 1-973-585-4747

TABLE MAINTENANCE AND CARE

Table Top –

- It is OK to gently vacuum the felt side of the billiard table with any standard handheld vacuum brush attachment.



www.eastpointsports.com