

OPERATOR'S MANUAL

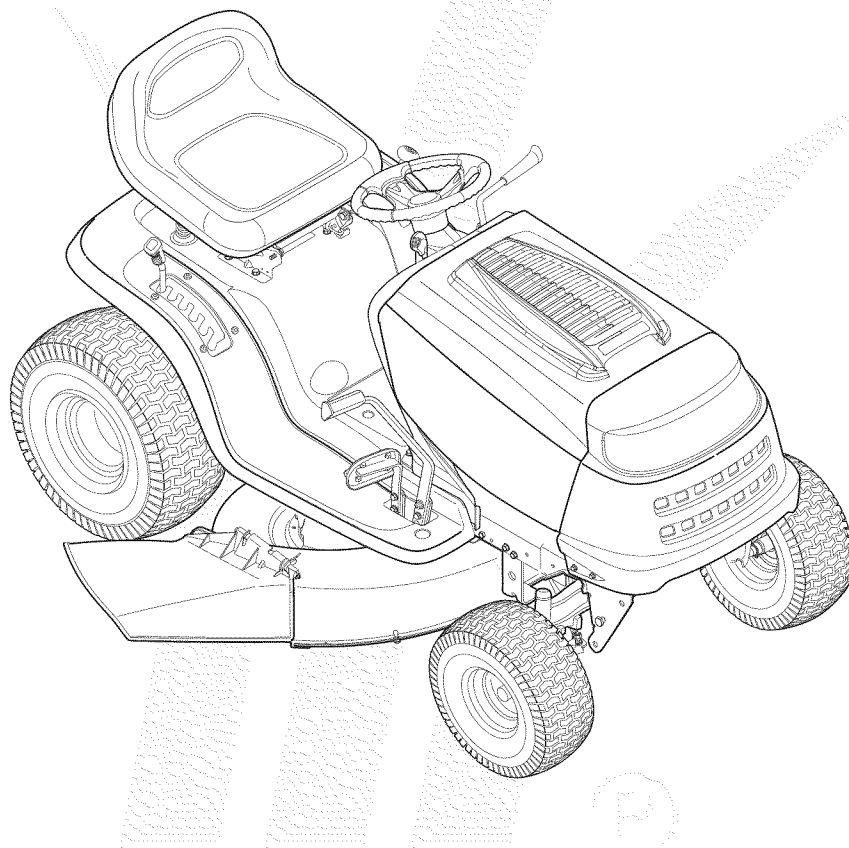

Automatic Lawn Tractor — Model Series 605

IMPORTANT

READ SAFETY RULES AND INSTRUCTIONS CAREFULLY BEFORE OPERATION

Warning: This unit is equipped with an internal combustion engine and should not be used on or near any unimproved forest-covered, brush-covered or grass-covered land unless the engine's exhaust system is equipped with a spark arrester meeting applicable local or state laws (if any). If a spark arrester is used, it should be maintained in effective working order by the operator. In the State of California the above is required by law (Section 4442 of the California Public Resources Code). Other states may have similar laws. Federal laws apply on federal lands. A spark arrester for the muffler is available through your nearest engine authorized service dealer or contact the service department, P.O. Box 361131 Cleveland, Ohio 44136-0019.

This Operator's Manual is an important part of your new lawn tractor. It will help you assemble, prepare and maintain the unit for best performance. Please read and understand what it says.

Table of Contents

Slope Gauge	3	Maintaining Your Lawn Tractor	24
Safe Operation Practices	4	Off-Season Storage / Attachments	30
Setting Up Your Lawn Tractor	8	Safety Labels	31
Operating Your Lawn Tractor	12	Trouble Shooting	32
Adjusting Your Lawn Tractor	20	Parts List	34

Finding and Recording Model Number

BEFORE YOU START ASSEMBLING YOUR NEW EQUIPMENT,

please locate the model plate on the equipment and copy the information to the sample model plate provided to the right. You can locate the model plate by looking beneath the seat. This information will be necessary to use the manufacturer's web site and/or obtain assistance from the Customer Support Department or an authorized service dealer.



MTD LLC
P. O. BOX 361131
CLEVELAND, OH 44136
330-220-4683
800-800-7310

Customer Support

Please do **NOT** return the unit to the retailer from which it was purchased, without first contacting Customer Support.

If you have difficulty assembling this product or have any questions regarding the controls, operation, or maintenance of this unit, you can seek help from the experts. Choose from the options below:

1. Visit **yardman.com**. Click on the Service & Support menu option.
2. Phone a **Customer Support Representative** at 1 (800) 800-7310.
3. The **engine manufacturer** is responsible for all engine-related issues with regards to performance, power-rating, specifications, warranty and service. Please refer to the engine manufacturer's Owner's/Operator's Manual, packed separately with your unit, for more information.

Yard-Man	Yard Machines	Manuals Online	Parts Online	Service Locator	Product Registration
----------	---------------	----------------	--------------	-----------------	----------------------

Need help using this site? Find instructions [here](#).

When searching this site, using fewer key words is more efficient than sentences or long phrases.

Answers My Stuff Login Help

Products & Services ⓘ All Products Search Text (optional) Search Tips Search

Search by Similar Phrases

Powered by RightNow

1

Slope Gauge

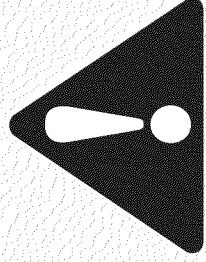

WARNING

Do not mow on inclines with a slope in excess of 15 degrees (a rise of approximately 2-1/2 feet every 10 feet). A riding mower could overturn and cause serious injury. If operating a walk-behind mower on such a slope, it is extremely difficult to maintain your footing and you could slip, resulting in serious injury.

Operate **RIDING** mowers up and down slopes, never across the face of slopes.

Operate **WALK-BEHIND** mowers across the face of slopes, never up and down slopes.

Use this page as a guide to determine slopes where you may not operate safely. **Do not operate** your lawn mower on such slopes.

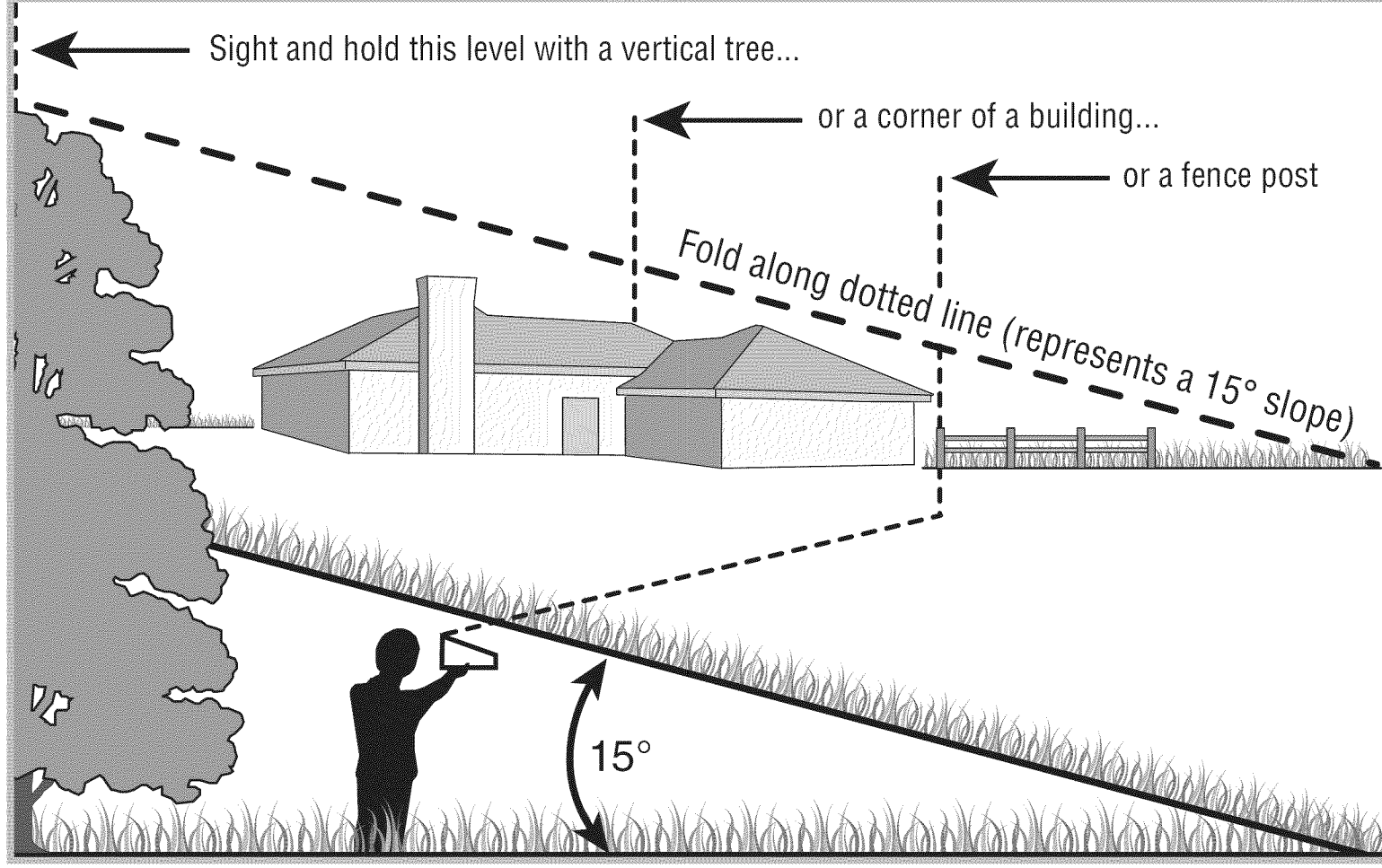

2

Safe Operation Practices



WARNING

This symbol points out important safety instructions which, if not followed, could endanger the personal safety and/or property of yourself and others. Read and follow all instructions in this manual before attempting to operate this machine. Failure to comply with these instructions may result in personal injury. When you see this symbol.

HEED ITS WARNING

Your Responsibility

Restrict the use of this power machine to persons who read, understand and follow the warnings and instructions in this manual



WARNING: Engine Exhaust, some of its constituents, and certain vehicle components contain or emit chemicals known to State of California to cause cancer and birth defects or other reproductive harm.

DANGER: This machine was built to be operated according to the rules for safe operation in this manual. As with any type of power equipment, carelessness or error on the part of the operator can result in serious injury. This machine is capable of amputating hands and feet and throwing objects. Failure to observe the following safety instructions could result in serious injury or death.

Children

1. Tragic accidents can occur if the operator is not alert to the presence of children. Children are often attracted to the machine and the mowing activity. They do not understand the dangers. Never assume that children will remain where you last saw them.
 - a. Keep children out of the mowing area and in watchful care of a responsible adult other than the operator.
 - b. Be alert and turn machine off if a child enters the area.
 - c. Before and while backing, look behind and down for small children.
 - d. Never carry children, even with the blade(s) shut off. They may fall off and be seriously injured or interfere with safe machine operation.
 - e. Use extreme care when approaching blind corners, doorways, shrubs, trees or other objects that may block your vision of a child who may run into the machine.
 - f. **To avoid back-over accidents, always disengage the cutting blade(s) before shifting into Reverse. If equipped, the "Reverse Caution Mode" should not be used when children or others are around.**
 - g. Keep children away from hot or running engines. They can suffer burns from a hot muffler.
 - h. Remove key when machine is unattended to prevent unauthorized operation.
2. Never allow children under 14 years old to operate the machine. Children 14 years old and over should read and understand the operation instructions and safety rules in this manual and should be trained and supervised by a parent.

Operation

Safe Handling of Gasoline:

1. **To avoid personal injury or property damage use extreme care in handling gasoline. Gasoline is extremely flammable and the vapors are explosive.** Serious personal injury can occur when gasoline is spilled on yourself or your clothes which can ignite. Wash your skin and change clothes immediately.
 - a. Use only an approved gasoline container.
 - b. Never fill containers inside a vehicle or on a truck or trailer bed with a plastic liner. Always place containers on the ground away from your vehicle before filling.
 - c. When practical, remove gas-powered equipment from the truck or trailer and refuel it on the ground. If this is not possible, then refuel such equipment on a trailer with a portable container, rather than from a gasoline dispenser nozzle.
 - d. Keep the nozzle in contact with the rim of the fuel tank or container opening at all times until fueling is complete. Do not use a nozzle lock-open device.
 - e. Extinguish all cigarettes, cigars, pipes and other sources of ignition.
 - f. Never fuel machine indoors.
 - g. Never remove gas cap or add fuel while the engine is hot or running. Allow engine to cool at least two minutes before refueling.
 - h. Never over fill fuel tank. Fill tank to no more than ½ inch below bottom of filler neck to allow space for fuel expansion.
 - i. Replace gasoline cap and tighten securely.
 - j. If gasoline is spilled, wipe it off the engine and equipment. Move unit to another area. Wait 5 minutes before starting the engine.
 - k. To reduce fire hazards, keep machine free of grass, leaves, or other debris build-up. Clean up oil or fuel spillage and remove any fuel soaked debris.
 - l. Never store the machine or fuel container inside where there is an open flame, spark or pilot light as on a water heater, space heater, furnace, clothes dryer or other gas appliances.
 - m. Allow a machine to cool at least five minutes before storing.

General Operation:

1. Read, understand, and follow all instructions on the machine and in the manual(s) before attempting to assemble and operate. Keep this manual in a safe place for future and regular reference and for ordering replacement parts.
2. Be familiar with all controls and their proper operation. Know how to stop the machine and disengage them quickly.
3. Never allow children under 14 years old to operate this machine. Children 14 years old and over should read and understand the operation instructions and safety rules in this manual and should be trained and supervised by a parent.
4. Never allow adults to operate this machine without proper instruction.
5. To help avoid blade contact or a thrown object injury, keep bystanders, helpers, children and pets at least 75 feet from the machine while it is in operation. Stop machine if anyone enters the area.
6. Thoroughly inspect the area where the equipment is to be used. Remove all stones, sticks, wire, bones, toys, and other foreign objects which could be picked up and thrown by the blade(s). Thrown objects can cause serious personal injury.
7. Plan your mowing pattern to avoid discharge of material toward roads, sidewalks, bystanders and the like. Also, avoid discharging material against a wall or obstruction which may cause discharged material to ricochet back toward the operator.
8. Always wear safety glasses or safety goggles during operation and while performing an adjustment or repair to protect your eyes. Thrown objects which ricochet can cause serious injury to the eyes.
9. Wear sturdy, rough-soled work shoes and close-fitting slacks and shirts. Loose fitting clothes and jewelry can be caught in movable parts. Never operate this machine in bare feet or sandals.
10. Be aware of the mower and attachment discharge direction and do not point it at anyone. Do not operate the mower without the discharge cover or entire grass catcher in its proper place.
11. Do not put hands or feet near rotating parts or under the cutting deck. Contact with the blade(s) can amputate hands and feet.
12. A missing or damaged discharge cover can cause blade contact or thrown object injuries.
13. Stop the blade(s) when crossing gravel drives, walks, or roads and while not cutting grass.
14. Watch for traffic when operating near or crossing roadways. This machine is not intended for use on any public roadway.
15. Do not operate the machine while under the influence of alcohol or drugs.
16. Mow only in daylight or good artificial light.
17. Never carry passengers.
18. Disengage blade(s) before shifting into reverse. Back up slowly. Always look down and behind before and while backing to avoid a back-over accident.
19. Slow down before turning. Operate the machine smoothly. Avoid erratic operation and excessive speed.
20. Disengage blade(s), set parking brake, stop engine and wait until the blade(s) come to a complete stop before removing grass catcher, emptying grass, unclogging chute, removing any grass or debris, or making any adjustments.
21. Never leave a running machine unattended. Always turn off blade(s), place transmission in neutral, set parking brake, stop engine and remove key before dismounting.
22. Use extra care when loading or unloading the machine into a trailer or truck. This unit should not be driven up or down ramp(s), because the unit could tip over, causing serious personal injury. The unit must be pushed manually on ramp(s) to load or unload properly.
23. Muffler and engine become hot and can cause a burn. Do not touch.
24. Check overhead clearances carefully before driving under low hanging tree branches, wires, door openings etc., where the operator may be struck or pulled from the unit, which could result in serious injury.
25. Disengage all attachment clutches, depress the brake pedal completely and shift into neutral before attempting to start engine.
26. Your machine is designed to cut normal residential grass of a height no more than 10". Do not attempt to mow through unusually tall, dry grass (e.g., pasture) or piles of dry leaves. Dry grass or leaves may contact the engine exhaust and/or build up on the mower deck presenting a potential fire hazard.
27. Use only accessories and attachments approved for this machine by the machine manufacturer. Read, understand and follow all instructions provided with the approved accessory or attachment.
28. Data indicates that operators, age 60 years and above, are involved in a large percentage of riding mower-related injuries. These operators should evaluate their ability to operate the riding mower safely enough to protect themselves and others from serious injury.
29. If situations occur which are not covered in this manual, use care and good judgment. Contact your customer service representative for assistance.

2

Safe Operation Practices



WARNING

This symbol points out important safety instructions which, if not followed, could endanger the personal safety and/or property of yourself and others. Read and follow all instructions in this manual before attempting to operate this machine. Failure to comply with these instructions may result in personal injury. When you see this symbol.

HEED ITS WARNING

Your Responsibility

Restrict the use of this power machine to persons who read, understand and follow the warnings and instructions in this manual

2

Safe Operation Practices



This symbol points out important safety instructions which, if not followed, could endanger the personal safety and/or property of yourself and others. Read and follow all instructions in this manual before attempting to operate this machine. Failure to comply with these instructions may result in personal injury. When you see this symbol.

HEED ITS WARNING

Your Responsibility

Restrict the use of this power machine to persons who read, understand and follow the warnings and instructions in this manual

Slope Operation:

Slopes are a major factor related to loss of control and tip-over accidents which can result in severe injury or death. All slopes require extra caution. If you cannot back up the slope or if you feel uneasy on it, do not mow it.

For your safety, use the slope gauge included as part of this manual to measure slopes before operating this unit on a sloped or hilly area. If the slope is greater than 15 degrees as shown on the slope gauge, do not operate this unit on that area or serious injury could result.

Do:

1. Mow up and down slopes, not across. Exercise extreme caution when changing direction on slopes.
2. Watch for holes, ruts, bumps, rocks, or other hidden objects. Uneven terrain could overturn the machine. Tall grass can hide obstacles.
3. Use slow speed. Choose a low enough speed setting so that you will not have to stop or shift while on the slope. Tires may lose traction on slopes even though the brakes are functioning properly. Always keep machine in gear when going down slopes to take advantage of engine braking action.
4. Follow the manufacturer's recommendations for wheel weights or counterweights to improve stability.
5. Use extra care with grass catchers or other attachments. These can change the stability of the machine.
6. Keep all movement on the slopes slow and gradual. Do not make sudden changes in speed or direction. Rapid engagement or braking could cause the front of the machine to lift and rapidly flip over backwards which could cause serious injury.
7. Avoid starting or stopping on a slope. If tires lose traction, disengage the blade(s) and proceed slowly straight down the slope.

Do Not:

1. Do not turn on slopes unless necessary; then, turn slowly and gradually downhill, if possible.
2. Do not mow near drop-offs, ditches or embankments. The mower could suddenly turn over if a wheel is over the edge of a cliff, ditch, or if an edge caves in.
3. Do not try to stabilize the machine by putting your foot on the ground.
4. Do not use a grass catcher on steep slopes.
5. Do not mow on wet grass. Reduced traction could cause sliding.
6. Do not shift to neutral and coast downhill. Over-speeding may cause the operator to lose control of the machine resulting in serious injury or death.
7. Do not tow heavy pull behind attachments (e.g. loaded dump cart, lawn roller, etc.) on slopes greater than 5 degrees. When going down hill, the extra weight tends to push the tractor and may cause you to lose control. (e.g. tractor may speed up, braking and steering ability are reduced, attachment may jack-knife and cause tractor to overturn).

Towing:

1. Tow only with a machine that has a hitch designed for towing. Do not attach towed equipment except at the hitch point.
2. Follow the manufacturer's recommendation for weight limits for towed equipment and towing on slopes.
3. Never allow children or others in or on towed equipment.
4. On slopes, the weight of the towed equipment may cause loss of traction and loss of control.
5. Travel slowly and allow extra distance to stop.
6. Do not shift to neutral and coast downhill.

Service

1. Never run an engine indoors or in a poorly ventilated area. Engine exhaust contains carbon monoxide, an odorless, and deadly gas.
2. Before cleaning, repairing, or inspecting, make certain the blade(s) and all moving parts have stopped. Disconnect the spark plug wire and ground against the engine to prevent unintended starting.
3. Periodically check to make sure the blades come to complete stop within approximately (5) five seconds after operating the blade disengagement control. If the blades do not stop within the this time frame, your unit should be serviced professionally by an authorized MTD Service Dealer.
4. Check brake operation frequently as it is subjected to wear during normal operation. Adjust and service as required.
5. Check the blade(s) and engine mounting bolts at frequent intervals for proper tightness. Also, visually inspect blade(s) for damage (e.g., excessive wear, bent, cracked). Replace the blade(s) with the original equipment manufacturer's (O.E.M.) blade(s) only, listed in this manual. "Use of parts which do not meet the original equipment specifications may lead to improper performance and compromise safety!"
6. Mower blades are sharp. Wrap the blade or wear gloves, and use extra caution when servicing them.
7. Keep all nuts, bolts, and screws tight to be sure the equipment is in safe working condition.
8. Never tamper with the safety interlock system or other safety devices. Check their proper operation regularly.
9. After striking a foreign object, stop the engine, disconnect the spark plug wire(s) and ground against the engine. Thoroughly inspect the machine for any damage. Repair the damage before starting and operating.
10. Never attempt to make adjustments or repairs to the machine while the engine is running.
11. Grass catcher components and the discharge cover are subject to wear and damage which could expose moving parts or allow objects to be thrown. For safety protection, frequently check components and replace immediately with original equipment manufacturer's (O.E.M.) parts only, listed in this manual. "Use of parts which do not meet the original equipment specifications may lead to improper performance and compromise safety!"
12. Do not change the engine governor settings or over-speed the engine. The governor controls the maximum safe operating speed of the engine.
13. Maintain or replace safety and instruction labels, as necessary.
14. Observe proper disposal laws and regulations for gas, oil, etc. to protect the environment.

2

Safe Operation Practices



This symbol points out important safety instructions which, if not followed, could endanger the personal safety and/or property of yourself and others. Read and follow all instructions in this manual before attempting to operate this machine. Failure to comply with these instructions may result in personal injury. When you see this symbol.

HEED ITS WARNING

Your Responsibility

Restrict the use of this power machine to persons who read, understand and follow the warnings and instructions in this manual

3

Setting Up Your Lawn Tractor



WARNING

Use extreme care when handling gasoline. Gasoline is extremely flammable and the vapors are explosive. Never fuel machine indoors or while the engine is hot or running. Extinguish cigarettes, cigars, pipes, and other sources of ignition.



NOTE: This Operators Manual covers a range of product specifications for various models. Characteristics and features discussed and/or illustrated in this manual *may not* be applicable to all models. MTD LLC reserves the right to change product specifications, designs and equipment without notice and without incurring obligation.

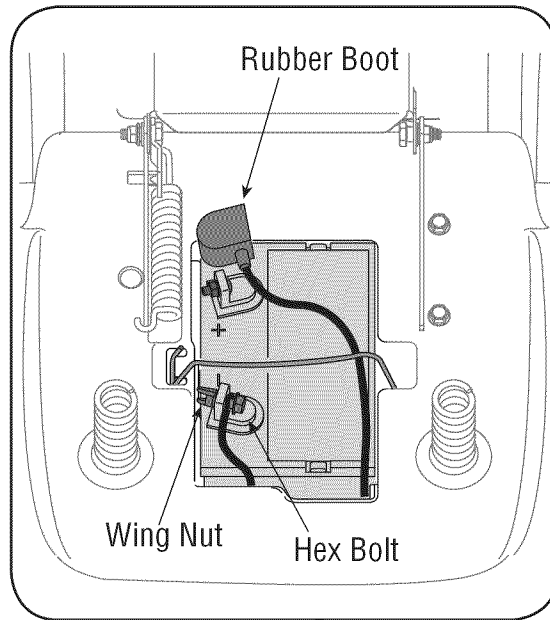

Figure 1

NOTE: This Operators Manual covers a range of product specifications for various models. Characteristics and features discussed and/or illustrated in this manual *may not* be applicable to all models. MTD LLC reserves the right to change product specifications, designs and equipment without notice and without incurring obligation.

Attaching the Battery Cables

NOTE: The positive battery terminal is marked Pos. (+). The negative battery terminal is marked Neg. (-).

- The positive cable (heavy red wire) is secured to the positive battery terminal (+) with a hex bolt and hex nut at the factory. Before attaching the negative cable, remove the battery by removing the positive cable and hold-down strap. Note the date on the side of the battery. If the battery is put into service after this date, charge the battery as instructed in the Maintaining Your Lawn Tractor section of this manual prior to operating the tractor.
- Secure battery back onto the tractor with the hold-down strap. Reattach the positive cable (heavy red wire) to the positive battery terminal (+) with the bolt and nut. Make certain that the rubber boot covers the terminal to help protect it from corrosion.
- Remove the hex bolt and wing nut from the negative cable.
- Remove the black plastic cover, if present, from the negative battery terminal and attach the negative cable (heavy black wire) to the negative battery terminal (-) with the bolt and nut.
- Make certain the hold-down strap is in position over the battery, securing it in place. See Figure 1.

Gas and Oil Fill-up

The gasoline tank is located under the hood and has a capacity of either two or three gallons. Do not overfill.



WARNING: Use extreme care when handling gasoline. Gasoline is extremely flammable and the vapors are explosive. Never fuel machine indoors or while the engine is hot or running. Extinguish cigarettes, cigars, pipes, and other sources of ignition.

Service the engine with gasoline and oil as instructed in the separate Engine Operator/Owner Manual packed with your tractor. Read instructions carefully.

IMPORTANT: Your tractor is shipped with motor oil in the engine. However, you **MUST** check the oil level before operating. Be careful not to overfill.

Shipping Brace Removal



WARNING: Make sure the riding mower's engine is off, remove the ignition key, and set the parking brake before removing the shipping brace.

- Locate the shipping brace, if present, and accompanying warning tag found on the right side of the mower, between the discharge chute and the cutting deck. See Figure 2.
- While holding the discharge chute with your left hand, remove the shipping brace with your right hand by grasping it between your thumb and index finger and rotating it clockwise.

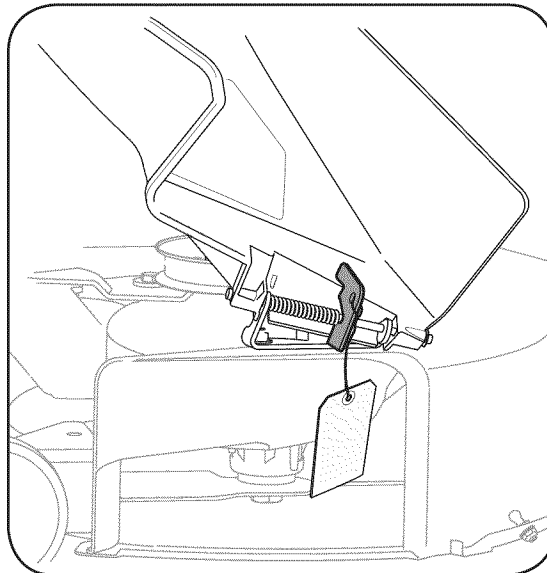

Figure 2



WARNING: The shipping brace, used for packaging purposes only, must be removed and discarded before operating your riding mower.



WARNING: The mowing deck is capable of throwing objects. Failure to operate the riding mower without the discharge cover in the proper operating position could result in serious personal injury and/or property damage.

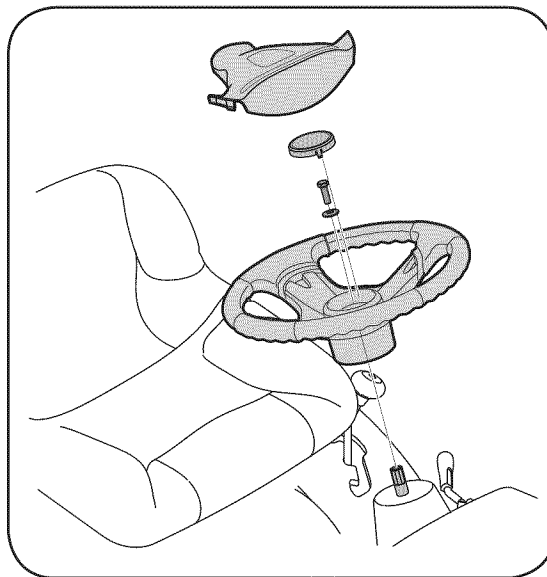

Figure 3

Attaching The Steering Wheel

If the steering wheel for your tractor did not come attached, the hardware for attaching it has been packed within the steering wheel, beneath the steering wheel cap. Carefully pry off the steering wheel cap and remove the hardware.

NOTE: There are two different styles of steering wheel cap. See Figure 3. **Styles vary by model.**

1. With the wheels of the tractor pointing straight forward, place the steering wheel over the steering shaft.
2. Place the washer (with the cupped side down) over the steering shaft and secure with the hex bolt. See Figure 3.
3. Place the steering wheel cap over the center of the steering wheel and push downward until it "clicks" into place.

3

Setting Up Your Lawn Tractor



WARNING

Make sure the riding mower's engine is off, remove the ignition key, and set the parking brake before removing the shipping brace.

The shipping brace, used for packaging purposes only, must be removed and discarded before operating your riding mower.

The mowing deck is capable of throwing objects. Failure to operate the riding mower without the discharge cover in the proper operating position could result in serious personal injury and/or property damage.

3

Setting Up Your Lawn Tractor



WARNING

Before operating this machine, make sure the seat is engaged in the seat stop, stand behind the machine and pull back on seat until fully engaged into stop.



NOTE: For shipping reasons, seats are either fastened to the tractor seat's pivot bracket with a plastic tie, or mounted backward to the pivot bracket. In either case, free the seat from its shipping position and remove the two hex screws (or knobs, on models so equipped) from the bottom of seat before proceeding with applicable instructions.

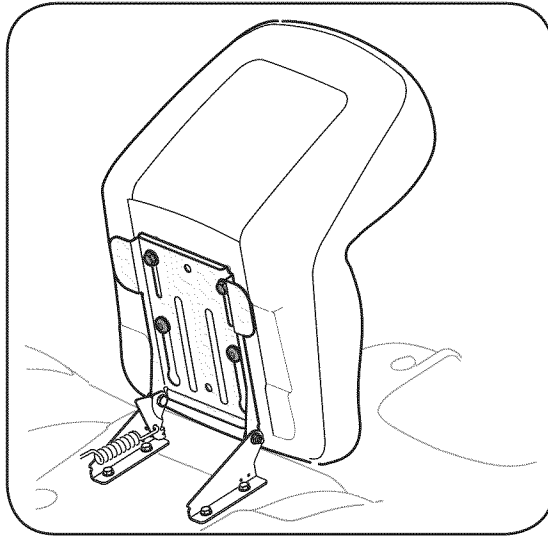

Figure 4

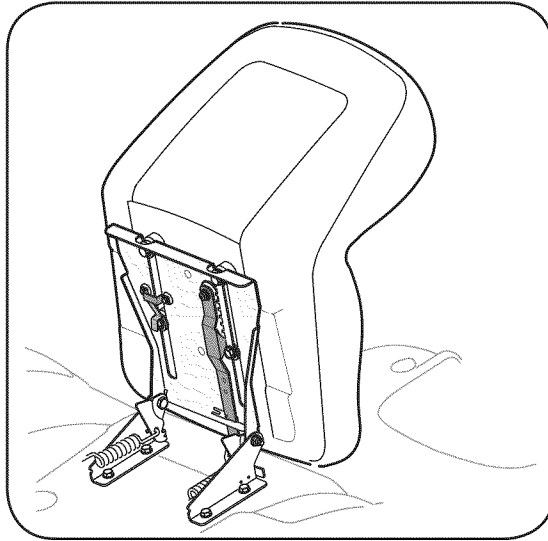

Figure 5

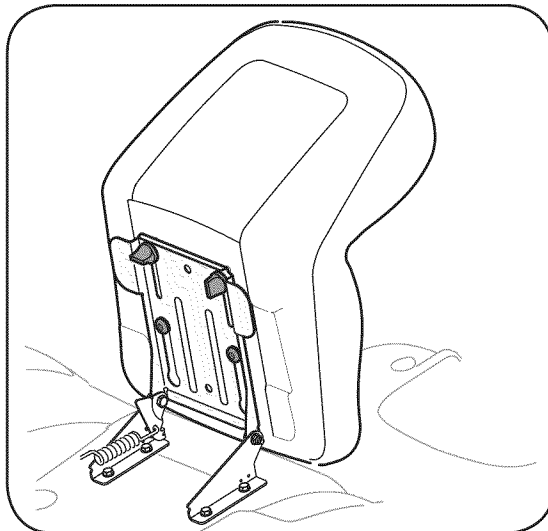

Figure 6

Attaching The Seat

Seat styles vary by tractor model and there are three different styles available:

- Standard Adjustment
- Quick Adjustment &
- Knob Adjustment

If the seat for your tractor did not come attached, refer to Figure 4, Figure 5, and Figure 6 to identify your tractor's seat style and follow the applicable instructions below to attach it.

NOTE: For shipping reasons, seats are either fastened to the tractor seat's pivot bracket with a plastic tie, or mounted backward to the pivot bracket. In either case, free the seat from its shipping position and remove the two hex screws (or knobs, on models so equipped) from the bottom of seat before proceeding with applicable instructions below.

Standard Adjustment Seat

1. Position the shoulder screws (found on the base of the seat) inside the slot openings in the seat pivot bracket. Figure 4.
2. Slide the seat slightly rearward in the seat pivot bracket, lining up the rear slots in the pivot bracket with the remaining two holes in the seat's base.
3. Select desired position for the seat, and secure with the two hex screws removed earlier. See Figure 4.

Quick Adjustment Seat

NOTE: If your seat was shipped mounted backwards on the seat pivot bracket, pull out the tab found on the seat stop and hold it open while sliding the seat off the seat pivot bracket. See Figure 5.

1. Line up the plastic seat spacers with the slots in seat pivot bracket.
2. Slide seat in until front seat spacer engages the seat stop. See Figure 5.



WARNING: Before operating this machine, make sure the seat is engaged in the seat stop, stand behind the machine and pull back on seat until fully engaged into stop.

Knob Adjustment Seat

1. Position the shoulder screws (found on the base of the seat) inside the slot openings in the seat pivot bracket. Figure 6.
2. Slide the seat slightly rearward in the seat pivot bracket, lining up the rear slots in the pivot bracket with the remaining two holes in the seat's base.
3. Select desired position for the seat, and secure with the two knobs removed earlier. See Figure 6.

Identifying the Mulch Plug

(if so equipped)

On tractor models so equipped, a mulch plug can either be found within the cutting deck's discharge opening or packed separately with your unit.

NOTE: Refer to **Mulching** on page 19 for more detailed information.

If you'd prefer to operate the cutting deck without mulching, simply remove the mulch plug by unthreading the plastic wing nut which fastens it to the cutting deck. This will allow the clippings to discharge out of the discharge opening during operation. See Figure 7.

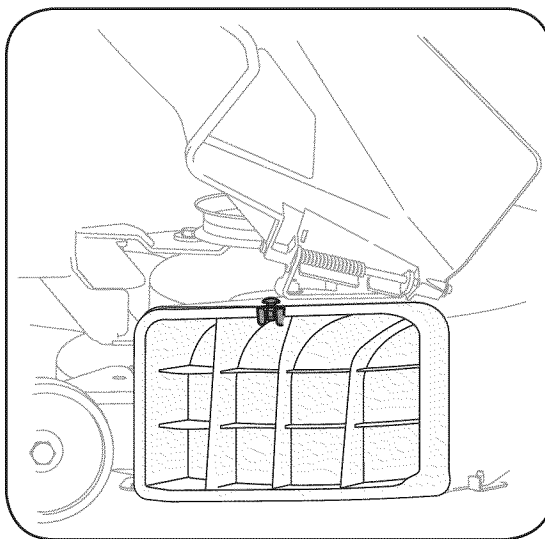

Figure 7

3

Setting Up Your Lawn Tractor



WARNING

4

Operating Your Lawn Tractor



NOTE: Any reference in this manual to the RIGHT or LEFT side of the tractor is observed from operator's position.

Know Your Lawn Tractor

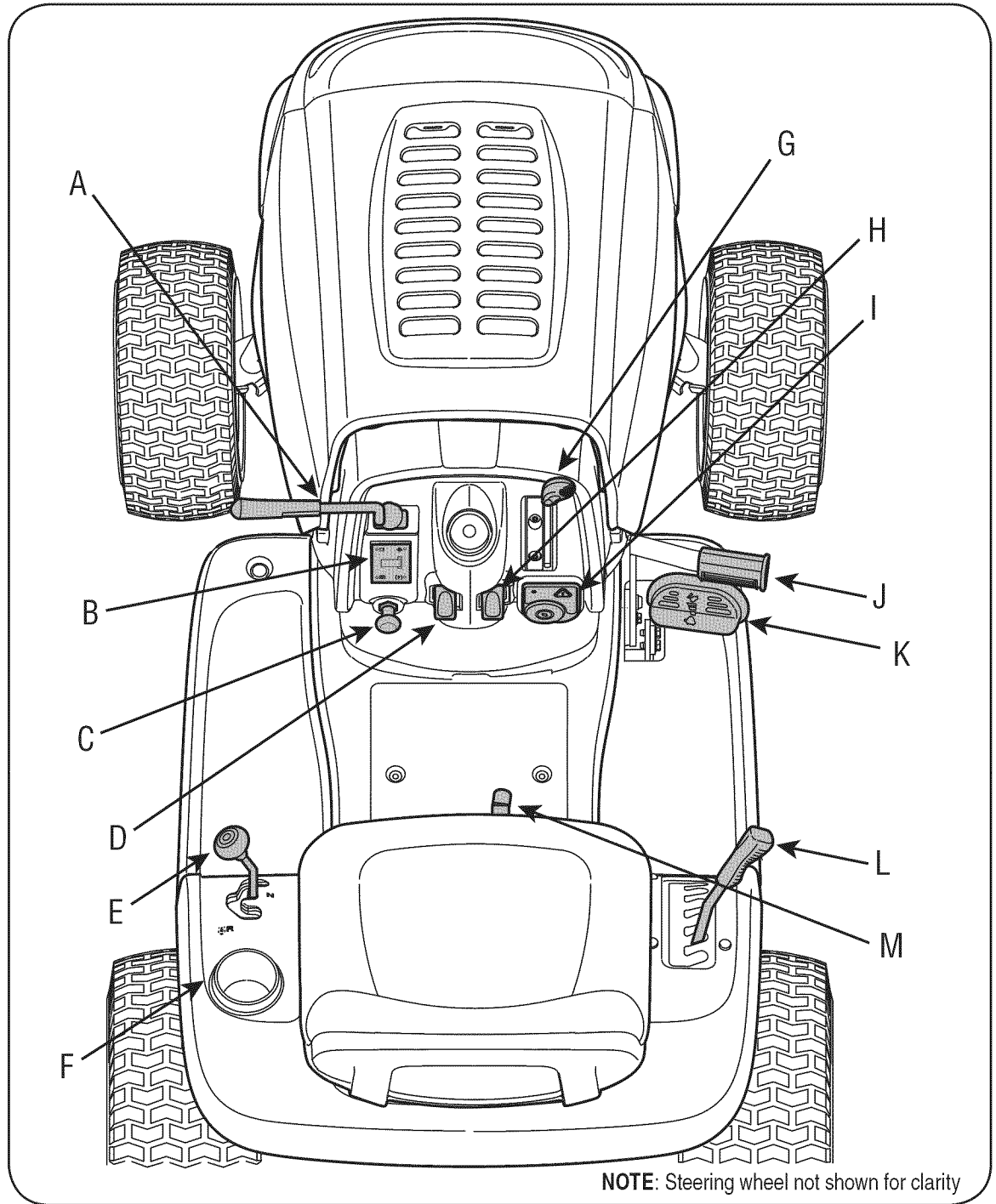

Figure 8

A	PTO (Blade Engage) Lever†	G	Throttle Lever
	PTO (Blade Engage) Knob†	H	Cruise Control Button
B	Systems Indicator Monitor†/Ammeter	I	Ignition Switch Module
C	Choke Knob†	J	Brake Pedal
D	Parking Brake Button	K	Drive Pedal
E	Shift Lever	L	Deck Lift Lever
F	Cup Holder	M	Seat Adjustment Lever†

† If so equipped

NOTE: Any reference in this manual to the RIGHT or LEFT side of the tractor is observed from operator's position.

Throttle Control Lever

The throttle control lever is located on the right side of the tractor's dash panel. This lever controls the speed of the engine and, on some models, when pushed all the way forward, the choke control also. When set in a given position, the throttle will maintain a uniform engine speed. See Figure 9.

IMPORTANT: When operating the tractor with the cutting deck engaged, be certain that the throttle lever is always in the FAST (rabbit) position.

Choke Control

On some models, moving the throttle lever all the way forward activates the engine's choke control. On all other models, the choke control can be found on the left side of the dash panel and is activated by pulling the knob outward. Activating the choke control closes the choke plate on the carburetor and aids in starting the engine. Refer to **Starting The Engine** in this section of the manual for detailed starting instructions.

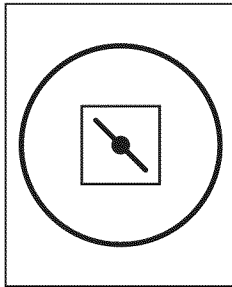

Brake Pedal

The brake pedal is located on the right front side of the tractor above the drive pedal along the running board. The brake pedal can be used for sudden stops or setting the parking brake.

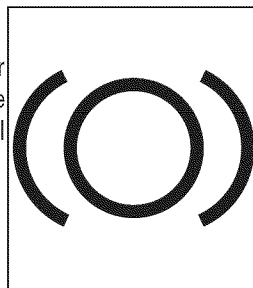

NOTE: The brake pedal must be fully depressed to activate the safety interlock switch when starting the tractor.

Ignition Switch Module



WARNING: Never leave a running machine unattended. Always disengage PTO, move shift lever into neutral position, set parking brake, stop engine and remove key to prevent unintended starting.

To start the engine, insert the key into the ignition switch and turn clockwise to the **START** position. Release the key into the **NORMAL MOWING MODE** position once the engine has fired.

To stop the engine, turn the ignition key counterclockwise to the OFF position. See Figure 10.

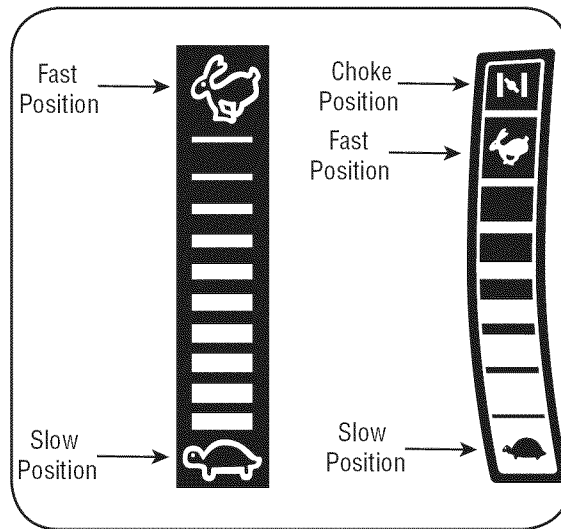

Figure 9

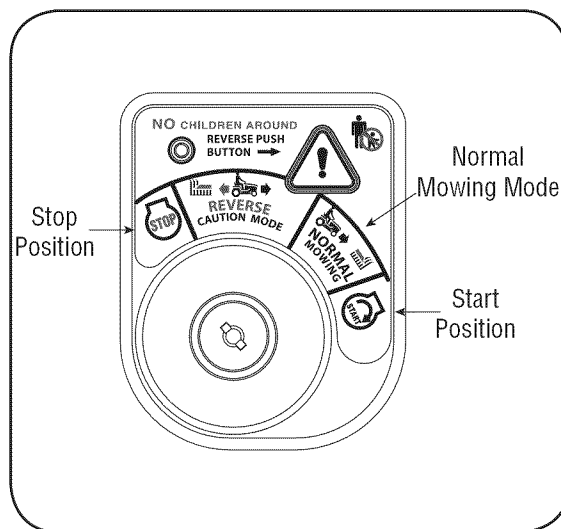
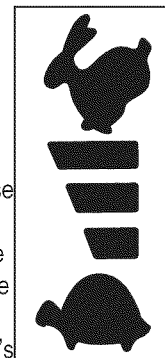

Figure 10

IMPORTANT: Prior to operating the tractor, refer to both **Safety Interlock Switches** and **Starting The Engine** in this section of the manual for detailed instructions regarding the Ignition Switch Module and operating the tractor in **REVERSE CAUTION MODE**.

Drive Pedal

The drive pedal is located below the brake pedal on the right front side of the tractor along the running board. Depress the drive pedal with your right foot when the tractor shift lever is in either FORWARD or REVERSE to cause the tractor to move. Ground speed is also controlled with the drive pedal. The further down the pedal is depressed, the faster the tractor will travel. The pedal will return to its original position when it's not depressed.



IMPORTANT: Always set the parking brake when leaving the tractor unattended.

4

Operating Your Lawn Tractor



WARNING

Never leave a running machine unattended. Always disengage PTO, move shift lever into neutral position, set parking brake, stop engine and remove key to prevent unintended starting.



IMPORTANT

Prior to operating the tractor, refer to both **Safety Interlock Switches** and **Starting The Engine** in this section of the manual for detailed instructions regarding the Ignition Switch Module and operating the tractor in **REVERSE CAUTION MODE**.

4

Operating Your Lawn Tractor



NOTE: The PTO (Blade Engage) knob must be in the disengaged (OFF) position when starting the engine, when traveling in reverse and if the operator leaves the seat.

NOTE: The PTO (Blade Engage) lever must be in the disengaged (OFF) position when starting the engine, when traveling in reverse and if the operator leaves the seat.

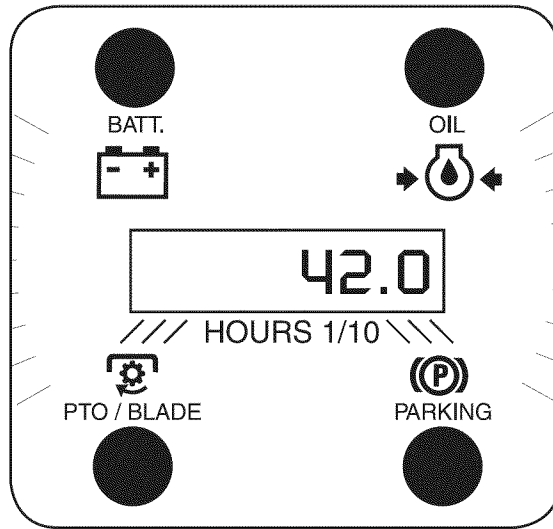

Figure 11
Systems Indicator Monitor (If Equipped)

LCD

Located in the center of the tractor's console, the systems indicator monitor records, and displays on its LCD, hours of tractor operation whenever the ignition key is rotated out of the STOP position. The Indicator Monitor will also remind the operator of maintenance intervals for changing the engine oil. The LCD will alternately flash the recorded hours, "CHG" and "OIL" for five minutes, after every 50 hours of recorded operation elapse. The maintenance interval lasts for two hours (from 50-52, 100-102, 150-152, etc.). The LCD will also flash as described above for five minutes every time the tractor's engine has been started during this maintenance interval. Before the interval expires, change the crankcase oil level as instructed in this Operator's Manual.

Brake

If the Brake light illuminates when attempting to start the tractor's engine, depress the brake pedal.

PTO (Blade Engage)

If the PTO light illuminates when attempting to start the tractor's engine, move PTO lever into the disengaged (OFF) position.

Oil

It is normal for the Oil light to illuminate while the engine is **cranking** during start-up, but if it illuminates during operation, **while the engine is running**, stop the tractor immediately and check the crankcase oil level as instructed in this Owner's Manual.

Battery

It is normal for the Battery light to illuminate while the engine is **cranking** during start-up, but if it illuminates during operation, **while the engine is running**, the battery is in need of a charge or the engine's charging system is not generating sufficient amperage. Refer to the **MAINTENANCE** section of this manual for the proper battery charging procedure or have the charging system checked by your service dealer.

Ammeter

The ammeter measures the electrical output of the engine's charging system. Under normal operating conditions, with engine at full throttle, the ammeter should indicate positive charge.

Electric PTO (Blade Engage) Knob (If Equipped)

To engage the power to the cutting deck or other (separately available) attachments on models equipped with an electric PTO, pull outward on the PTO (Blade Engage) knob. Push the PTO (Blade Engage) knob inward to disengage the power to the cutting deck.

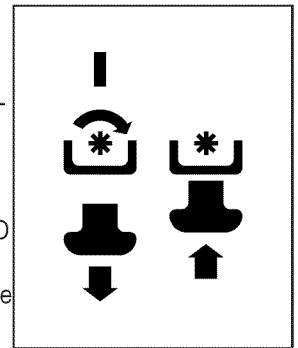

NOTE: The PTO (Blade Engage) knob **must** be in the disengaged (OFF) position when starting the engine, when traveling in reverse and if the operator leaves the seat.

PTO (Blade Engage) Lever

On models equipped with a manual PTO (Blade Engage), the PTO (Blade Engage) lever is located on the left side of

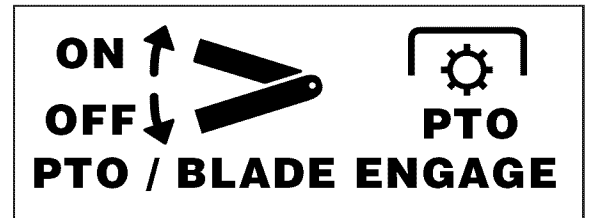

the dashboard next to the steering wheel. Move the PTO (Blade Engage) lever forward to engage the power to the cutting deck or other (separately available) attachments; move the PTO (Blade Engage) lever rearward to disengage the power to the attachments.

NOTE: The PTO (Blade Engage) lever **must** be in the disengaged (OFF) position when starting the engine, when traveling in reverse and if the operator leaves the seat.

Seat Adjustment Lever (If Equipped)

To adjust the seat forward or backward on units equipped with a quick-adjust seat, slide the seat adjustment lever to the left and reposition the seat to the desired position. Once a comfortable position is found, release the seat adjustment lever to lock the seat in place. Refer to the Adjusting Your Lawn Tractor section of this manual for more detailed instructions on all seat adjustments.

Deck Lift Lever

Found on your tractor's right fender, the deck lift lever is used to change the height of the cutting deck. To use, move the lever to the left, then place in the notch best suited for your application.

Parking Brake Button

To set the parking brake, fully depress the brake pedal and push the parking brake button in. Hold the button in while taking your foot off the brake pedal. Both the parking button and the brake pedal will then stay depressed. To release the parking brake, depress the brake pedal slightly. The parking brake button will then return to its original position.

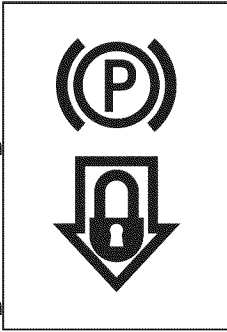

NOTE: The parking brake must be set if the operator leaves the seat with the engine running or the engine will automatically shut off.

IMPORTANT: Always set the parking brake when leaving the tractor unattended.

Cruise Control Button

The cruise control button is located on the tractor dash panel to the left of the ignition switch. Push the cruise control button while traveling forward at a desired speed. While holding the button in, release pressure from the drive pedal. This will engage the cruise control and allow the tractor to remain at that speed without applying pressure to the drive pedal. Depress the brake pedal or the drive pedal to deactivate cruise control. Refer to **Setting the Cruise Control** later in this section the manual for detailed instructions regarding the cruise control feature.

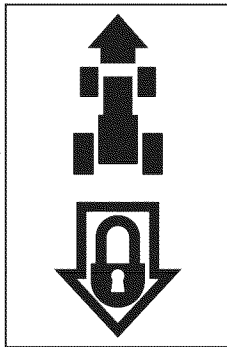

NOTE: Cruise control can NOT be engaged at the tractor's fastest ground speed. If the operator should attempt to do so, the tractor will automatically decelerate to the fastest optimal mowing ground speed.

Shift Lever

The shift lever is located on the left side of the fender and has three positions, FORWARD, NEUTRAL and REVERSE. The brake pedal must be depressed and the tractor must not be in motion when the moving shift lever.

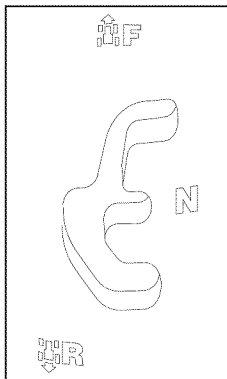

IMPORTANT: Never force the shift lever. Doing so may result in serious damage to the tractor's transmission.

Safety Interlock Switches

This tractor is equipped with a safety interlock system for the protection of the operator. If the interlock system should ever malfunction, do not operate the tractor. Contact an authorized MTD service dealer.

- The safety interlock system prevents the engine from cranking or starting unless the parking brake is engaged, and the PTO (Blade Engage) knob (or lever) is in the disengaged (OFF) position.
- The engine will automatically shut off if the operator leaves the seat before engaging the parking brake.

Models with Manual PTO (Blade Engage)

- The engine will automatically shut off if the operator leaves the tractor's seat with the PTO (Blade Engage) lever in the engaged (ON) position, regardless of whether the parking brake is engaged.
- With the ignition key in the **NORMAL MOWING** position, the engine will automatically shut off if the PTO (Blade Engage) lever is moved into the engaged (ON) position with the shift lever in Reverse.

Models with Electric PTO (Blade Engage)

- The electric PTO (Blade Engage) clutch will automatically shut off if the operator leaves the tractor's seat with the PTO (Blade Engage) knob in the engaged (ON) position, regardless of whether the parking brake is engaged.
- With the ignition key in the **NORMAL MOWING** position, the electric PTO (Blade Engage) clutch will automatically shut off if the PTO (Blade Engage) knob is moved into the engaged (ON) position with the shift lever in Reverse.



WARNING: Do not operate the tractor if the interlock system is malfunctioning. This system was designed for your safety and protection.

Reverse Caution Mode



WARNING: Use extreme caution while operating the tractor in the **REVERSE CAUTION MODE**. Always look down and behind before and while backing. Do not operate the tractor when children or others are around. Stop the tractor immediately if someone enters the area.

4

Operating Your Lawn Tractor



WARNING

Do not operate the tractor if the interlock system is malfunctioning. This system was designed for your safety and protection.

Use extreme caution while operating the tractor in the **REVERSE CAUTION MODE**. Always look down and behind before and while backing. Do not operate the tractor when children or others are around. Stop the tractor immediately if someone enters the area.

4

Operating Your Lawn Tractor



WARNING

Keep hands and feet away from the discharge opening of the cutting deck.

Do not operate the tractor if the interlock system is malfunctioning. This system was designed for your safety and protection.

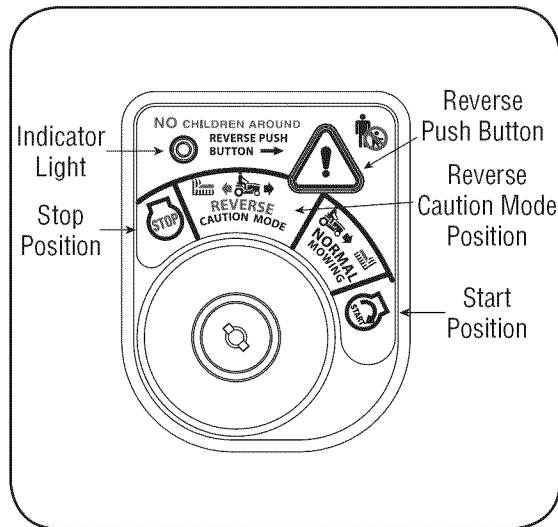

Figure 12

The **REVERSE CAUTION MODE** position of the key switch module allows the tractor to be operated in reverse with the blades (PTO) engaged.

IMPORTANT: Mowing in reverse is not recommended.

To use the **REVERSE CAUTION MODE:**

IMPORTANT: The operator **MUST** be seated in the tractor seat.

1. Start the engine as previously instructed in this Operator's Manual.
2. Turn the key from the **NORMAL MOWING** (Green) position to the **REVERSE CAUTION MODE** (Yellow) position of the key switch module. See Figure 12.
3. Depress the **REVERSE PUSH BUTTON** (Orange, Triangular Button) at the top, right corner of the key switch module. The red indicator light at the top, left corner of the key switch module will be **ON** while activated. See Figure 12.
4. Once activated (indicator light **ON**), the tractor can be driven in reverse with the cutting blades (PTO) engaged.
5. Always look down and behind before and while backing to make sure no children are around.
6. After resuming forward motion, return the key to the **NORMAL MOWING** position.

IMPORTANT: The **REVERSE CAUTION MODE** will remain activated until:

- a. The key is placed in either the **NORMAL MOWING** position or **STOP** position.
- b. The operator leaves the seat (Models with Electric PTO ONLY).
- c. The operator engages the parking brake by fully depressing the brake pedal and holding it down while gently pushing the parking brake button inward (Models with Manual PTO ONLY).



WARNING

AVOID SERIOUS INJURY OR DEATH

- GO UP AND DOWN SLOPES, NOT ACROSS.
- AVOID SUDDEN TURNS.
- DO NOT OPERATE THE UNIT WHERE IT COULD SLIP OR TIP.
- IF MACHINE STOPS GOING UPHILL, STOP BLADE(S) AND BACK DOWNHILL SLOWLY.
- DO NOT MOW WHEN CHILDREN OR OTHERS ARE AROUND.
- NEVER CARRY CHILDREN, EVEN WITH BLADES OFF.
- LOOK DOWN AND BEHIND BEFORE AND WHILE BACKING.
- KEEP SAFETY DEVICES (GUARDS, SHIELDS, AND SWITCHES) IN PLACE AND WORKING.
- REMOVE OBJECTS THAT COULD BE THROWN BY THE BLADE(S).
- KNOW LOCATION AND FUNCTION OF ALL CONTROLS.
- BE SURE BLADE(S) AND ENGINE ARE STOPPED BEFORE PLACING HANDS OR FEET NEAR BLADE(S).
- BEFORE LEAVING OPERATOR'S POSITION, DISENGAGE BLADE(S), PLACE THE SHIFT LEVER IN NEUTRAL, ENGAGE BRAKE LOCK, SHUT ENGINE OFF AND REMOVE KEY.

READ OPERATOR'S MANUAL

Engaging the Parking Brake

To engage the parking brake:

1. Fully depress the brake pedal and hold it down with your foot while gently pushing the parking brake button inward.
2. Hold the parking brake button in while removing your foot from the brake pedal.
3. Once engaged, the parking brake button and the brake pedal will lock in the "down" position.

To disengage the parking brake:

1. Slightly depress the brake pedal.

NOTE: The parking brake must be engaged if the operator leaves the seat with the engine running or the engine will automatically shut off.

Setting the Cutting Height

1. Select the height position of the cutting deck by placing the deck lift lever in any of the six different cutting height notches on the right side of the fender.
2. Adjust the deck wheels so that they are between ¼-inch and ½-inch above the ground when the tractor is on a smooth, flat surface such as a driveway.



WARNING: Keep hands and feet away from the discharge opening of the cutting deck.

NOTE: The deck wheels are an anti-scalp feature of the deck and are not designed to support the weight of the cutting deck.

Refer to **Leveling the Deck** on page 20 of this manual for more detailed instructions regarding various deck adjustments.

Starting the Engine



WARNING: Do not operate the tractor if the interlock system is malfunctioning. This system was designed for your safety and protection.

NOTE: Refer to the **TRACTOR SET-UP** on page 8 of this manual for Gasoline and Oil fill-up instructions.

1. Insert the tractor key into the ignition switch.
2. Place the PTO (Blade Engage) knob (or lever) in the disengaged (OFF) position.
3. Engage the tractor's parking brake.
4. Activate the choke control.
5. Turn the ignition key clockwise to the START position. After the engine starts, release the key. It will return to the ON position.

IMPORTANT: Do NOT hold the key in the START position for longer than ten seconds at a time. Doing so may cause damage to your engine's electric starter.

6. After the engine starts, deactivate the choke control and place the throttle control in the FAST position.

NOTE: Do NOT leave the choke control on while operating the tractor. Doing so will result in a "rich" fuel mixture and cause the engine to run poorly.

Stopping the Engine



WARNING: If you strike a foreign object, stop the engine, disconnect the spark plug wire(s) and ground against the engine. Thoroughly inspect the machine for any damage. Repair the damage before restarting and operating

1. If the blades are engaged, place the PTO (Blade Engage) knob (or lever) in the disengaged (OFF) position.
2. Turn the ignition key counterclockwise to the STOP position.
3. Remove the key from the ignition switch to prevent unintended starting.

Driving The Tractor



WARNING: Avoid sudden starts, excessive speed and sudden stops.

WARNING: Do not leave the seat of the tractor without first placing the PTO (Blade Engage) knob (or lever) in the disengaged (OFF) position, depressing the brake pedal and engaging the parking brake. If leaving the tractor unattended, also turn the ignition key off and remove the key.

1. Depress the brake pedal to release the parking brake and let the pedal up.
2. Move the throttle lever into the FAST (rabbit) position.

IMPORTANT: Do NOT use the shift lever to change the direction of travel when the tractor is in motion. Always use the brake pedal to bring the tractor to a complete stop before shifting.

3. To move forward, place the shift lever in the FORWARD position, then slowly depress the drive pedal until the desired speed is achieved.

4

Operating Your Lawn Tractor



WARNING

If you strike a foreign object, stop the engine, disconnect the spark plug wire(s) and ground against the engine. Thoroughly inspect the machine for any damage. Repair the damage before restarting and operating.

Avoid sudden starts, excessive speed and sudden stops.

Do not leave the seat of the tractor without first placing the PTO (Blade Engage) knob (or lever) in the disengaged (OFF) position, depressing the brake pedal and engaging the parking brake. If leaving the tractor unattended, also turn the ignition key off and remove the key.

4

Operating Your Lawn Tractor



WARNING

Do not mow on inclines with a slope in excess of 15 degrees (a rise of approximately 2-1/2 feet every 10 feet). The tractor could overturn and cause serious injury.

To help avoid blade contact or a thrown object injury, keep bystanders, helpers, children and pets at least 75 feet from the machine while it is in operation. Stop machine if anyone enters the area.

4. To move in reverse, place the shift lever in the REVERSE position, check that the area behind is clear then slowly depress the drive pedal.

Driving On Slopes

Refer to the SLOPE GAUGE on page 3 to help determine slopes where you may operate the tractor safely.



WARNING: Do not mow on inclines with a slope in excess of 15 degrees (a rise of approximately 2-1/2 feet every 10 feet). The tractor could overturn and cause serious injury.

- Mow up and down slopes, NEVER across.
- Exercise extreme caution when changing direction on slopes.
- Watch for holes, ruts, bumps, rocks, or other hidden objects. Uneven terrain could overturn the machine. Tall grass can hide obstacles.
- Avoid turns when driving on a slope. If a turn must be made, turn down the slope. Turning up a slope greatly increases the chance of a roll over.
- Avoid stopping when driving up a slope. If it is necessary to stop while driving up a slope, start up smoothly and carefully to reduce the possibility of flipping the tractor over backward.

Setting The Cruise Control

1. Place the shift lever in the FORWARD position, then slowly depress the drive pedal until the desired speed is achieved.
2. Lightly depress the cruise control button.
3. While continuing to hold the cruise button in, lift your foot from the drive pedal (you should feel the cruise latch engage).

Once engaged, the cruise control button and the drive pedal will lock in the "down" position, and the tractor will maintain the same forward speed.

NOTE: Cruise control can not be engaged at the tractor's fastest ground speed. If the operator should attempt to do so, the tractor will automatically decelerate to the fastest optimal mowing ground speed.

Disengage the cruise control using one of the following methods:

1. Depress the brake pedal to disengage the cruise control and stop the tractor.
2. Lightly depress the drive pedal.

To change to the reverse direction when operating with cruise control, depress the brake pedal to disengage the cruise control and bring the tractor to a complete stop. Then place the shift lever in the REVERSE position and depress the drive pedal.

Engaging the Blades

Engaging the PTO (Blade Engage) transfers power to the cutting deck or other (separately available) attachments. To engage the blades, proceed as follows:

1. Move the throttle control lever to the FAST (rabbit) position.

Models with Manual PTO

2. a. Grasp the PTO (Blade Engage) lever and pivot it all the way forward into the engaged (ON) position.

Models with Electric PTO

- b. Pull the PTO (Blade Engage) knob outward into the engaged (ON) position.
3. Keep the throttle lever in the FAST (rabbit) position for the most efficient use of the cutting deck or other (separately available) attachments

IMPORTANT: The engine (on models with a manual PTO) or electric PTO clutch (on models with an electric PTO) will automatically shut off if the PTO is engaged with the shift lever in position for reverse travel with the ignition key in the NORMAL MOWING position. Refer to Safety Interlock Switches earlier in this section.

Using the Deck Lift Lever

To raise the cutting deck, move the deck lift lever to the left, then place it in the notch best suited for your application. Refer to Setting The Cutting Height earlier in this section.

Mowing



WARNING: To help avoid blade contact or a thrown object injury, keep bystanders, helpers, children and pets at least 75 feet from the machine while it is in operation. Stop machine if anyone enters the area.

The following information will be helpful when using the cutting deck with your tractor:



WARNING: Plan your mowing pattern to avoid discharge of materials toward roads, sidewalks, bystanders and the like. Also, avoid discharging material against a wall or obstruction which may cause discharged material to ricochet back toward the operator.

- Do not mow at high ground speed, especially if a mulch kit or grass collector is installed.
- For best results it is recommended that the first two laps be cut with the discharge thrown towards the center. After the first two laps, reverse the direction to throw the discharge to the outside for the balance of cutting. This will give a better appearance to the lawn.
- Do not cut the grass too short. Short grass invites weed growth and yellows quickly in dry weather.
- Mowing should always be done with the engine at full throttle.
- Under heavier conditions it may be necessary to go back over the cut area a second time to get a clean cut.
- Do NOT attempt to mow heavy brush and weeds and extremely tall grass. Your tractor is designed to mow lawns, NOT clear brush.
- Keep the blades sharp and replace the blades when worn. Refer to **Cutting Blades** in the Maintaining Your Lawn Tractor section of this manual for proper blade sharpening instructions.

Mulching (If Equipped)

Select models come equipped with a mulch kit which incorporates special blades, already standard on the tractor, in a process of recirculating grass clippings repeatedly beneath the cutting deck. The ultra-fine clippings are then forced back into the lawn where they act as a natural fertilizer.

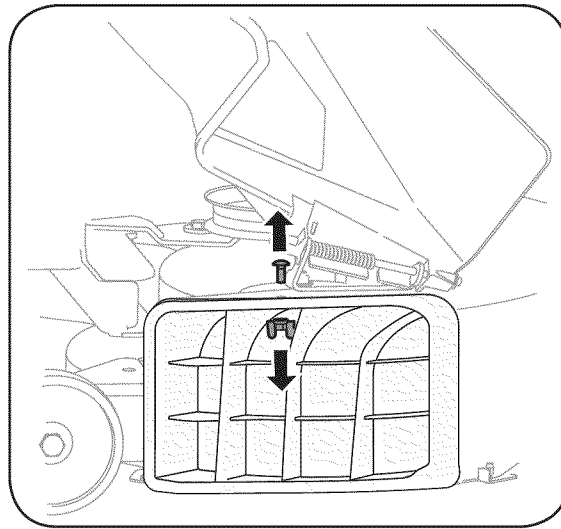

Figure 13

Observe the following points for the best results when mulching:

- Never attempt to mulch if the lawn is damp. Wet grass tends to stick to the underside of the cutting deck preventing proper mulching of the clippings.
- Do NOT attempt to mulch more than 1/3 the total height of the grass or approximately 1-1/2 inches. Doing so will cause the clippings to clump up beneath the deck and not be mulched effectively.
- Maintain a slow ground speed to allow the grass clippings more time to effectively be mulched.
- Always position the throttle control lever in the FAST (rabbit) position and allow it to remain there while mowing. Failing to keep the engine at full throttle places strain on the tractor's engine and does not allow the blades to properly mulch grass.

NOTE: It is not necessary to remove the discharge chute to operate the mower with the mulch kit installed.

To operate the cutting deck without mulching, simply remove the mulch plug by unthreading the plastic wing nut which fastens it to the cutting deck. This will allow the clippings to discharge out the side. See Figure 13.

Headlights

- The lamps are ON whenever the ignition key is moved out of the STOP position.
- The lamps turn OFF when the ignition key is moved to the STOP position.

4

Operating Your Lawn Tractor



WARNING

Plan your mowing pattern to avoid discharge of materials toward roads, sidewalks, bystanders and the like. Also, avoid discharging material against a wall or obstruction which may cause discharged material to ricochet back toward the operator.

5

Adjusting Your Lawn Tractor



WARNING

Never attempt to make any adjustments while the engine is running, except where specified in the operator's manual.



NOTE: Check the tractor's tire pressure before performing any deck leveling adjustments. Refer to Tires on page 26 for information regarding tire pressure.

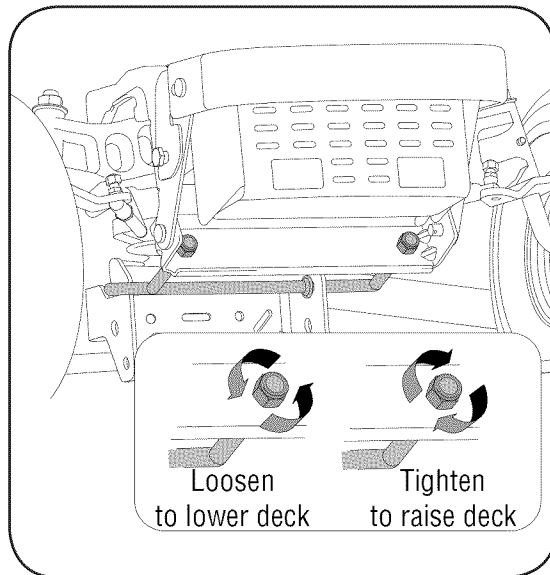

Figure 14

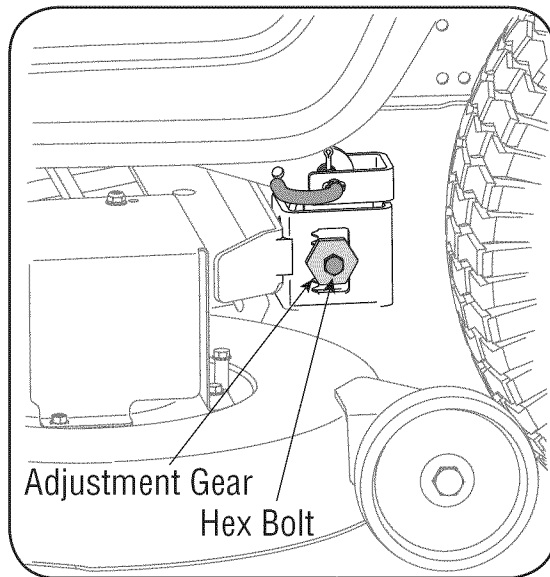

Figure 15



WARNING: Never attempt to make any adjustments while the engine is running, except where specified in the operator's manual.

Leveling the Deck

NOTE: Check the tractor's tire pressure before performing any deck leveling adjustments. Refer to Tires on page 26 for information regarding tire pressure.

Front To Rear

The front of the cutting deck is supported by a stabilizer bar that can be adjusted to level the deck from front to rear. The front of the deck should be between 1/4-inch and 3/8-inch lower than the rear of the deck. Adjust if necessary as follows:

1. With the tractor parked on a firm, level surface, place the deck lift lever in the top notch (highest position) and rotate the blade nearest the discharge chute so that it is parallel with the tractor.
2. Measure the distance from the front of the blade tip to the ground and the rear of the blade tip to the ground. The first measurement taken should be between 1/4" and 3/8" less than the second measurement. Determine the approximate distance necessary for proper adjustment and proceed, if necessary, to the next step.
3. From the front of the tractor, loosen the hex lock nut on each end of the deck hanger rod, and turn away from the inner hex nuts. See Figure 14.
4. Tighten the inner hex nuts front against the front hanger bracket to raise the front of the deck; loosen the hex nuts to lower the front of the deck.

NOTE: Models with a 42-inch deck have only ONE jam nut, washer, and lock nut.

5. Retighten the two lock nuts against the inner hex nuts when proper adjustment is achieved.

Side to Side

If the cutting deck appears to be mowing unevenly, a side to side adjustment can be performed. Adjust if necessary as follows:

1. With the tractor parked on a firm, level surface, place the deck lift lever in the top notch (highest position) and rotate both blades so that they are perpendicular with the tractor.
2. Measure the distance from the outside of the left blade tip to the ground and the distance from the outside of the right blade tip to the ground. Both measurements taken should be equal. If they're not, proceed to the next step.
3. Loosen, but do NOT remove, the hex cap screw on the left deck hanger bracket. See Figure 15.
4. Balance the deck by using a wrench to turn the adjustment gear (found immediately behind the hex cap screw just loosened) clockwise/up or counter-clockwise/down. The deck is properly balanced when both blade tip measurements taken earlier are equal.
5. Retighten the hex cap screw on the left deck hanger bracket when proper adjustment is achieved.

Parking Brake Adjustment



WARNING: Never attempt to adjust the brakes while the engine is running. Always disengage PTO, move shift lever into neutral position, stop engine and remove key to prevent unintended starting.

If the tractor does not come to a complete stop when the brake pedal is completely depressed, or if the tractor's rear wheels can roll with the parking brake applied, the brake is in need of adjustment. The brake disc can be found on the right side of the transmission in the rear of the tractor. Adjust if necessary as follows:

1. Looking at the transmission from the right side of the tractor, locate the compression spring and brake disc. See Figure 16.
2. Loosen, but do NOT remove, the hex nut found on the right side of the brake assembly. See Figure 16.
3. Using a feeler gauge, set the gap between the brake disc and the brake puck at .011".
4. Re-tighten the hex nut loosened earlier.

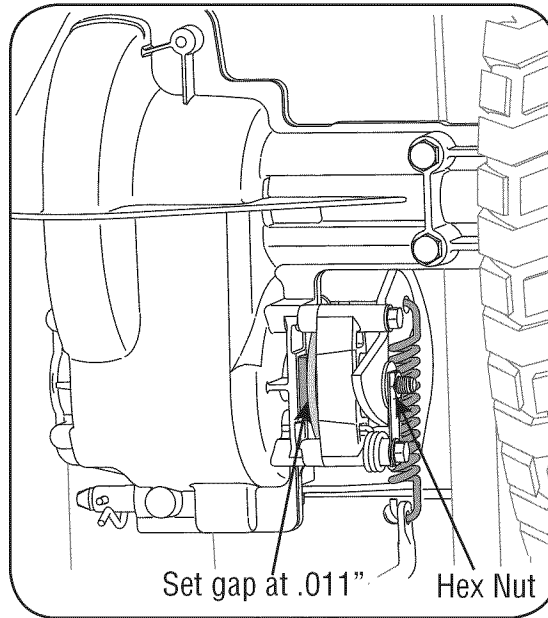

Figure 16

5

Adjusting Your Lawn Tractor



WARNING

Never attempt to adjust the brakes while the engine is running. Always disengage PTO, move shift lever into neutral position, stop engine and remove key to prevent unintended starting.

5

Adjusting Your Lawn Tractor



WARNING

Before operating this machine, make sure the seat is engaged in the seat stop, stand behind the machine and pull back on seat until fully engaged into stop.

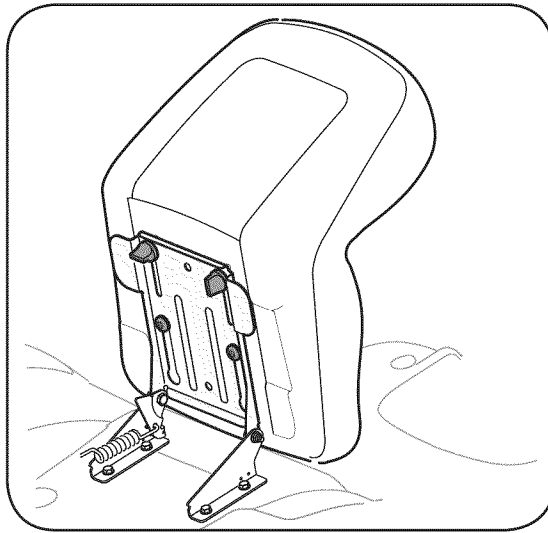

Figure 17

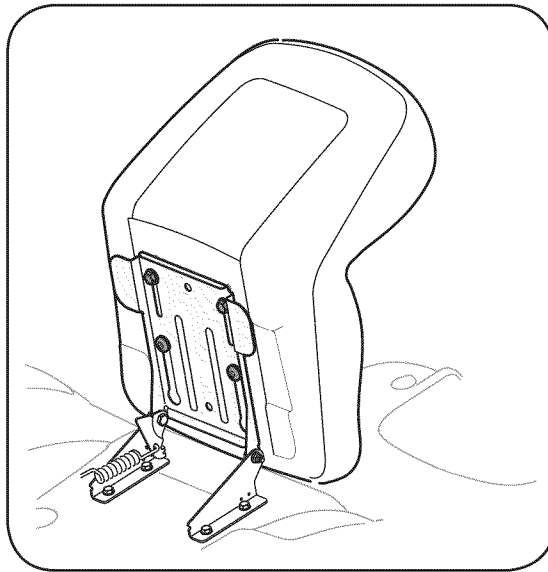

Figure 18

Seat Adjustment

Quick Adjust Seat (if so equipped)



WARNING: Before operating this machine, make sure the seat is engaged in the seat stop, stand behind the machine and pull back on seat until fully engaged into stop.

- To adjust the position of the seat on models equipped with a seat adjustment lever, move the lever to the left and slide the seat forward or rearward. Refer to the Setting Up Your Lawn Tractor section. Make sure seat is locked into position before operating the tractor.

Knob Adjustment Seat (if so equipped)

To adjust the position of the seat on models so equipped, loosen the two knobs on the bottom of the seat. See Figure 17. Slide the seat forward or backward as desired. Retighten the two knobs.

Standard Seat (if so equipped)

To adjust the position of the seat, loosen the two hex screws on the bottom of the seat. Slide the seat forward or backward as desired. Retighten the two screws. See Figure 18.

Steering Adjustment

If the tractor turns tighter in one direction than the other, or if the ball joints are being replaced due to damage or wear, the steering drag links may need to be adjusted.

Adjust the drag links so that equal lengths are threaded into the ball joint on the left and right side:

1. Loosen the jam nut found on the drag link at the rear of the ball joint. See Figure 19.
2. Remove hex nut on the top of ball joint. See Figure 19.
3. Thread the ball joint toward the jam nut to shorten the drag link. Thread the ball joint away from the jam nut to lengthen the drag link.
4. Replace hex nut and retighten the jam nut after proper adjustment is achieved.

NOTE: Threading the ball joints too far onto the drag links will cause the front tires to “toe-in” too far. Proper toe-in is between 1/16” and 5/16”.

Front tire toe-in can be measured as follows:

1. Place the steering wheel in position for straight ahead travel.
2. In front of the axle, measure the distance horizontally from the inside of the left rim to the inside of the right rim. Note the distance.
3. Behind the axle, measure the distance horizontally from the inside of the left rim to the inside of the right rim. Note the distance.
4. The measurement taken in front of the axle should be between 1/16” and 5/16” less than the measurement taken behind the axle. Adjust if necessary.

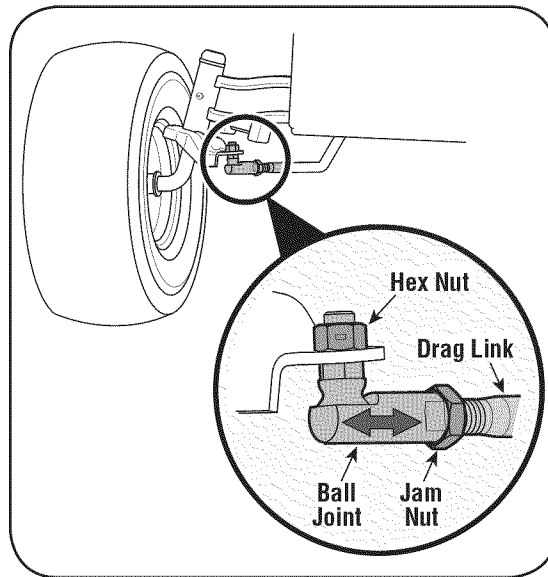

Figure 19

5

Adjusting Your Lawn Tractor



NOTE: Threading the ball joints too far onto the drag links will cause the front tires to “toe-in” too far. Proper toe-in is between 1/16” and 5/16”.

6

Maintaining Your Lawn Tractor



WARNING

Before performing any maintenance or repairs, disengage PTO, move shift lever into neutral position, set parking brake, stop engine and remove key to prevent unintended starting.

Before lubricating, repairing, or inspecting, always disengage PTO, move shift lever into neutral position, set parking brake, stop engine and remove key to prevent unintended starting.



NOTE: Depending on the engine model found on your tractor, it may be necessary to remove the tractor's side panel in order to replace the oil filter (if so equipped).

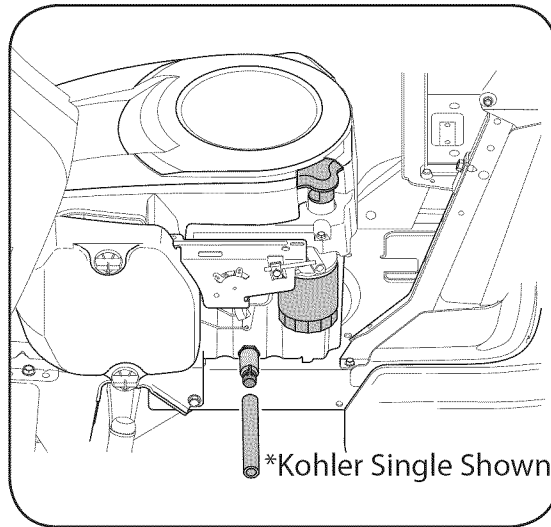

Figure 20



WARNING: Before performing any maintenance or repairs, disengage PTO, move shift lever into neutral position, set parking brake, stop engine and remove key to prevent unintended starting.

Engine

Refer to the Engine Operator/Owner Manual for engine maintenance instructions. Check engine oil level before each use as instructed in the Engine Operator/Owner Manual packed with your unit. Follow the instructions carefully.

Changing Engine Oil

NOTE: Depending on the engine model found on your tractor, it may be necessary to remove the tractor's side panel in order to replace the oil filter (if so equipped).

1. Pop open the protective cap on the end of the oil drain valve to expose the drain port. See Figure 20.
2. Remove the oil fill cap/ dipstick from the oil fill tube.
3. Push the oil drain hose (packed with this manual) onto the oil drain port. Route the opposite end of the hose into an appropriate oil collection container with a capacity great enough to collect the used oil.
4. After the oil has finished draining, push the oil drain valve back in, rotate it clockwise to lock the valve closed and re-cap the end of the oil drain valve to keep debris from entering the drain port.
5. Service the oil filter (if so equipped) as instructed in the separate Engine Operator/Owner Manual packed with your unit.

Perform the above steps in the opposite order after oil has finished draining.

6. Refill the engine with new motor oil as instructed in the Engine Operator/Owner Manual packed with your unit.

IMPORTANT: Refer to the Engine Operator/Owner Manual packed with your unit for information regarding the quantity and proper weight of motor oil.

Air Cleaner

Service the pre-cleaner, if so equipped, and cartridge/air cleaner element as instructed in the Engine Operator/Owner Manual packed with your unit.

Spark Plug(s)

The spark plug(s) should be cleaned and the gap reset once a season. Spark plug replacement is recommended at the start of each mowing season. Refer to the Engine Operator/Owner Manual for correct plug type and gap specifications.

Lubrication



WARNING: Before lubricating, repairing, or inspecting, always disengage PTO, move shift lever into neutral position, set parking brake, stop engine and remove key to prevent unintended starting.

Engine

Lubricate the engine with motor oil as instructed in the Engine Owner Manual packed with your unit.

Pivot Points & Linkage

Lubricate all the pivot points on the drive system, parking brake and lift linkage at least once a season with light oil.

Rear Wheels

The rear wheels should be removed from the axles once a season. Lubricate the axles and the rims well with an all-purpose grease before re-installing them.

Front Axles

Each end of the tractor's front pivot bar may be equipped with a grease fitting. Lubricate with a grease gun after every 25 hours of tractor operation.

Cleaning the Engine And Deck

Any fuel or oil spilled on the machine should be wiped off promptly. Do NOT allow debris to accumulate around the cooling fins of the engine or on any other part of the machine.

IMPORTANT: The use of a pressure washer to clean your tractor is NOT recommended. It may cause damage to electrical components, spindles, pulleys, bearings or the engine.

Deck Wash System™

Your tractor's deck may be equipped with a water port on its surface as part of its deck wash system.

Use the Deck Wash System™ to rinse grass clippings from the deck's underside and prevent the buildup of corrosive chemicals. Complete the following steps AFTER EACH MOWING:

1. Drive the tractor to a level, clear spot on your lawn, near enough to a water sillcock (spigot) for your garden hose to reach.

IMPORTANT: Make certain the tractor's discharge chute is directed AWAY from your house, garage, parked cars, etc.

2. Disengage the PTO (Blade Engage), move the shift lever into the neutral position, set the parking brake, and stop the engine.
3. Thread the hose coupler (packaged with your tractor's Operator's Manual) onto the end of your garden hose.
4. Attach the hose coupler to the water port on your decks surface. See Figure 21.
5. Turn the water on.
6. While sitting in the operator's position on the tractor, re-start the engine and place the throttle lever in the FAST (rabbit) position.
7. Disengage the parking brake.
8. Move the tractor's PTO (Blade Engage) into the ON position.
9. **Remain in the operator's position** with the cutting deck engaged for a minimum of two minutes, allowing the underside of the cutting deck to thoroughly rinse.
10. Move the tractor's PTO (Blade Engage) into the OFF position.
11. Turn the ignition key to the STOP position to turn the tractor's engine off and engage the parking brake.
12. Turn the water off and detach the hose coupler from the water port on your decks surface.
13. Repeat steps 4-11 on the opposite side of the cutting deck.

Cutting Deck Removal

To remove the cutting deck, proceed as follows:

1. Place the PTO (Blade Engage) knob (or lever) in the disengaged (OFF) position and engage the parking brake.
2. Lower the deck by moving the deck lift lever into the bottom notch on the right fender.
3. Remove the hairpin clip that secures the PTO cable to the rear of the cutting deck. See Figure 22. Remove the PTO cable and accompanying spring from the cutting deck.
4. Remove the deck belt from around the tractor's engine pulley (or electric PTO clutch, if so equipped).

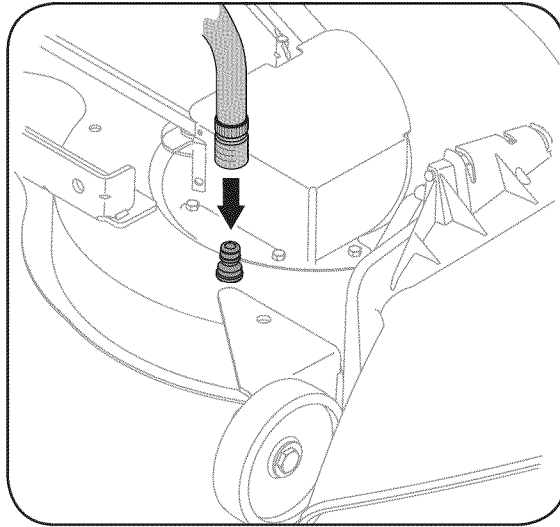

Figure 21

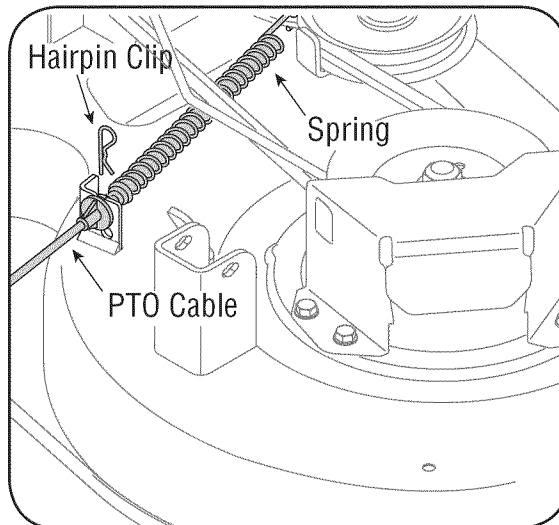

Figure 22

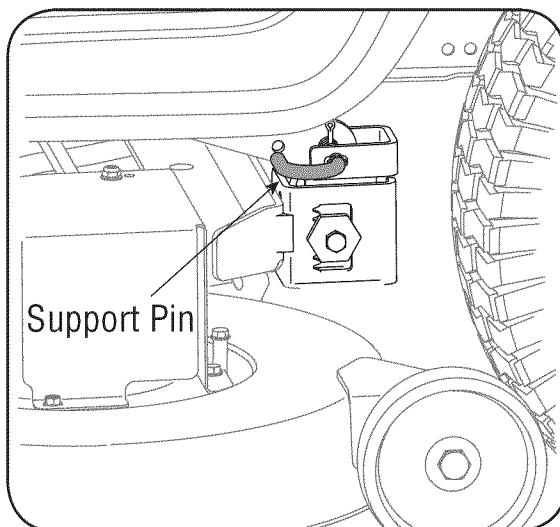

Figure 23

6

Maintaining Your Lawn Tractor



IMPORTANT

Make certain the tractor's discharge chute is directed AWAY from your house, garage, parked cars, etc.

NOTE: On models with a 46-inch deck, it may be necessary to remove the belt keepers from around the engine pulley, in order to remove the PTO belt.

6

Maintaining Your Lawn Tractor



WARNING

Never exceed the maximum inflation pressure shown on the sidewall of the tire.

Batteries give off an explosive gas while charging. Charge battery in a well ventilated area and keep away from an open flame or pilot light as on a water heater, space heater, furnace, clothes dryer or other gas appliances.

- Looking at the cutting deck from the left side of the tractor, locate the deck support pin on the rear left side of the deck. See Figure 23.
- Pull the deck support pin outward to release the deck from the deck lift arm.
- Rotate the pin slightly toward the rear of the tractor and release the pin into the hole provided.
- Repeat the above steps on the tractor's right side.
- Move the deck lift lever into the top notch on the right fender to raise deck lift arms up and out of the way.
- Gently slide the cutting deck toward the front of the tractor allowing the hooks on the deck to release themselves from the deck stabilizer rod.
- Gently slide the cutting deck (from the right side) out from underneath the tractor.

Tires



WARNING: Never exceed the maximum inflation pressure shown on the sidewall of tire.

The recommended operating tire pressure is:

- Approximately 10 psi for the rear tires
- Approximately 14 psi for the front tires

IMPORTANT: Refer to the tire sidewall for exact tire manufacturer's recommended or maximum psi. Do not overinflate. Uneven tire pressure could cause the cutting deck to mow unevenly.

Battery

The battery is sealed and is maintenance-free. Acid levels cannot be checked.

- Always keep the battery cables and terminals clean and free of corrosive build-up.
- After cleaning the battery and terminals, apply a light coat of petroleum jelly or grease to both terminals.
- Always keep the rubber boot positioned over the positive terminal to prevent shorting.

IMPORTANT: If removing the battery for any reason, disconnect the NEGATIVE (Black) wire from its terminal first, followed by the POSITIVE (Red) wire. When re-installing the battery, always connect the POSITIVE (Red) wire its terminal first, followed by the NEGATIVE (Black) wire. Be certain that the wires are connected to the correct terminals; reversing them could change the polarity and result in damage to your engine's alternat-ing system.

Charging

If the tractor has not been put into use for an extended period of time, charge the battery with an automotive-type 12-volt charger for a minimum of **one hour at six amps**.



WARNING: Batteries give off an explosive gas while charging. Charge battery in a well ventilated area and keep away from an open flame or pilot light as on a water heater, space heater, furnace, clothes dryer or other gas appliances.

Jump Starting



WARNING: When removing or installing the battery, follow these instructions to prevent the screwdriver from shorting against the frame.

IMPORTANT: Never jump your tractor's dead battery with the battery of a running vehicle.

- Connect end of one jumper cable to the positive terminal of the good battery, then the other end to the positive terminal of the dead battery.
- Connect the other jumper cable to the negative terminal of the good battery, then to the **frame of the unit with the dead battery**.



WARNING: Failure to use this procedure could cause sparking, and the gas in either battery could explode.

Cleaning

Clean the battery by removing it from the tractor and washing with a baking soda and water solution. If necessary, scrape the battery terminals with a wire brush to remove deposits. Coat terminals and exposed wiring with grease or petroleum jelly to prevent corrosion.

Battery Failures

Some common causes for battery failure are:

- incorrect initial activation
- undercharging
- overcharging
- corroded connections
- freezing

These failures are NOT covered by your tractor's warranty.

Cutting Blades



WARNING: Be sure to shut the engine off, remove ignition key, disconnect the spark plug wire(s) and ground against the engine to prevent unintended starting before removing the cutting blade(s) for sharpening or replacement. Protect your hands by using heavy gloves or a rag to grasp the cutting blade.

WARNING: Periodically inspect the blade spindles for cracks or damage, especially if you strike a foreign object. Replace immediately if damaged.

The blades may be removed as follows.

1. Remove the deck from beneath the tractor, (refer to Cutting Deck Removal on page 25) then gently flip the deck over to expose its underside.
2. Place a block of wood between the center deck housing baffle and the cutting blade to act as a stabilizer. See Figure 24.
3. Use a 15/16" wrench to remove the hex flange nut that secures the blade to the spindle assembly. See Figure 24.
4. To properly sharpen the cutting blades, remove equal amounts of metal from both ends of the blades along the cutting edges, parallel to the trailing edge, at a 25° to 30° angle.

IMPORTANT: If the cutting edge of the blade has already been sharpened to within 1 5/8" from the edge, or if any metal separation is present, replace the blades with new ones. See Figure 25.

- It is important that each cutting blade edge be ground equally to maintain proper blade balance.
- When replacing the blade, be sure to install the blade with the side of the blade marked "Bottom" (or with a part number stamped in it) facing the ground when the mower is in the operating position.

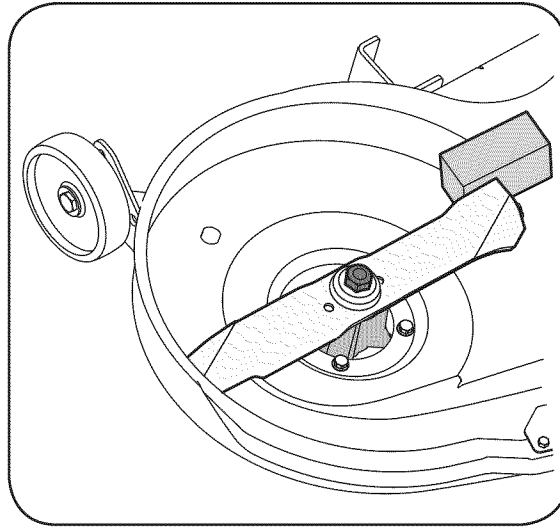

Figure 24

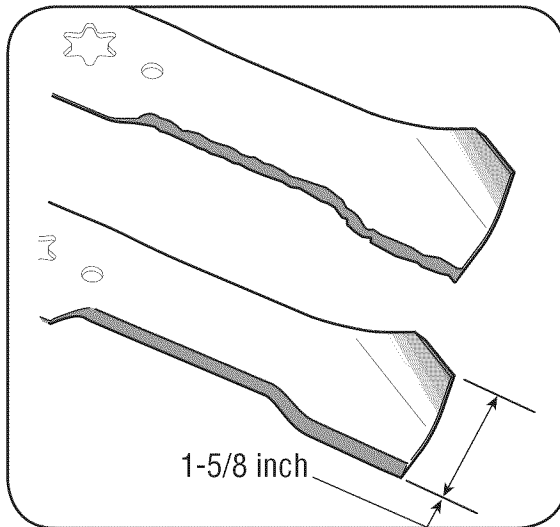

Figure 25

IMPORTANT: Use a torque wrench to tighten the blade spindle hex flange nut to between 70 foot-pounds and 90 foot-pounds.

Fuses

- A fuse is installed in your tractor's wiring harness to protect the tractor's electrical system from damage caused by excessive amperage.
- If the electrical system does not function, or your tractor's engine will not crank, first check to be certain that the fuse has not blown.
- It can either be found under the hood mounted behind the top of the dash panel on the support bar, or under the seat mounted to the inside of the tractor frame next to the battery tray.



Always use a fuse with the same amperage capacity for replacement.

6

Maintaining Your Lawn Tractor



WARNING

Be sure to shut the engine off, remove ignition key, disconnect the spark plug wire(s) and ground against the engine to prevent unintended starting before removing the cutting blade(s) for sharpening or replacement. Protect your hands by using heavy gloves or a rag to grasp the cutting blade.

Periodically inspect the blade spindles for cracks or damage, especially if you strike a foreign object. Replace immediately if damaged.

Always use a fuse with the same amperage capacity for replacement.

6

Maintaining Your Lawn Tractor



WARNING

Be sure to shut the engine off, remove ignition key, disconnect the spark plug wire(s) and ground against the engine to prevent unintended starting before removing the belt(s).

Avoid the possibility of a pinching injury. Do not place your fingers on the idler spring or between the belt and a pulley while removing the belt.

Changing the Deck Belt



WARNING: Be sure to shut the engine off, remove ignition key, disconnect the spark plug wire(s) and ground against the engine to prevent unintended starting before removing the belt(s).

All belts on your tractor are subject to wear and should be replaced if any signs of wear are present.

IMPORTANT: The V-belts found on your tractor are specially designed to engage and disengage safely. A substitute (non-OEM) V-belt can be dangerous by not disengaging completely. For a proper working machine, use factory approved belts.

To change or replace the deck belt on your tractor, proceed as follows:

1. Remove the belt keeper rod(s) from around the engine pulley.
2. Remove the cutting deck as instructed earlier in this section.
3. Remove the belt guards by removing the self-tapping screws that fasten them to the deck.

4. Carefully loosen, but do not remove, the deck idler pulleys.
5. Remove the deck belt from around all pulleys, including the deck idler pulleys and the electric PTO clutch (units with electric PTO).
6. Route the new belt as shown in Figure 26, 27, and 28 and retighten the deck idler pulleys.
7. Reinstall the belt guards removed earlier and remount the deck to the tractor.
8. Route the belt around the engine pulley and reinstall the belt keeper rod(s).

Changing the Lower Deck Belt (46" Decks)

NOTE: Several components must be removed in order to change the tractor's lower deck belt. See an authorized MTD Service Dealer to have your lower drive belt replaced or phone Customer Support as instructed on page 2 for information on ordering a Service Manual.

Changing the Transmission Drive Belt

NOTE: Several components must be removed and special tools (i.e. air/impact wrench) in order to change the tractor's drive belt. See an authorized MTD Service Dealer to have your drive belt replaced or phone Customer Support as instructed on page 2 for information on ordering a Service Manual.

6

Maintaining Your Lawn Tractor

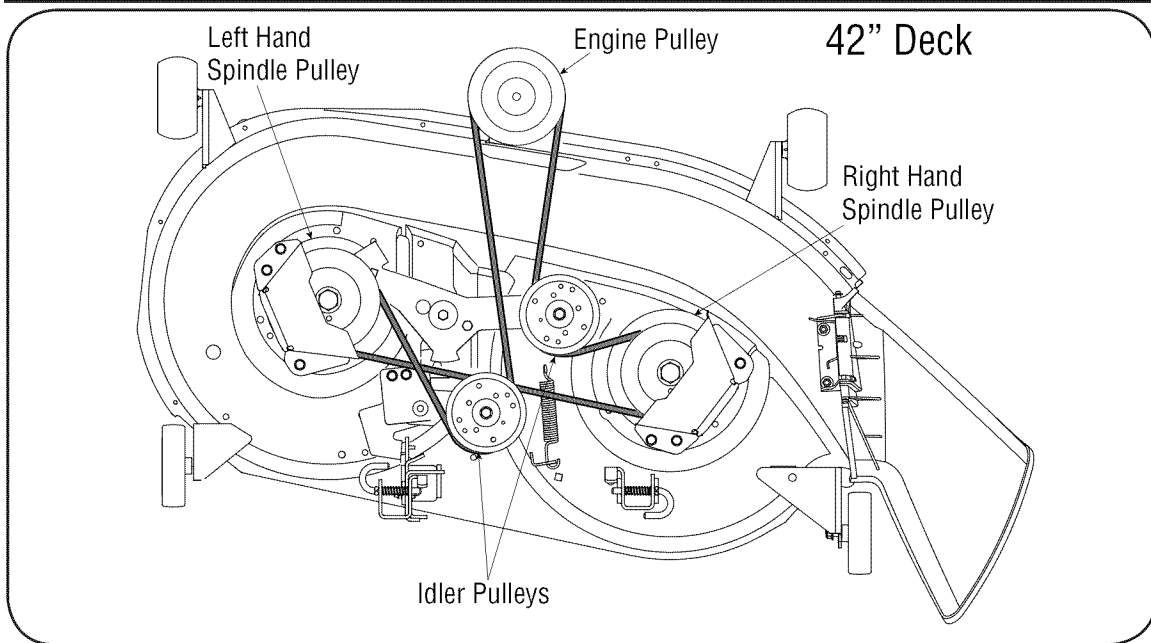

Figure 26

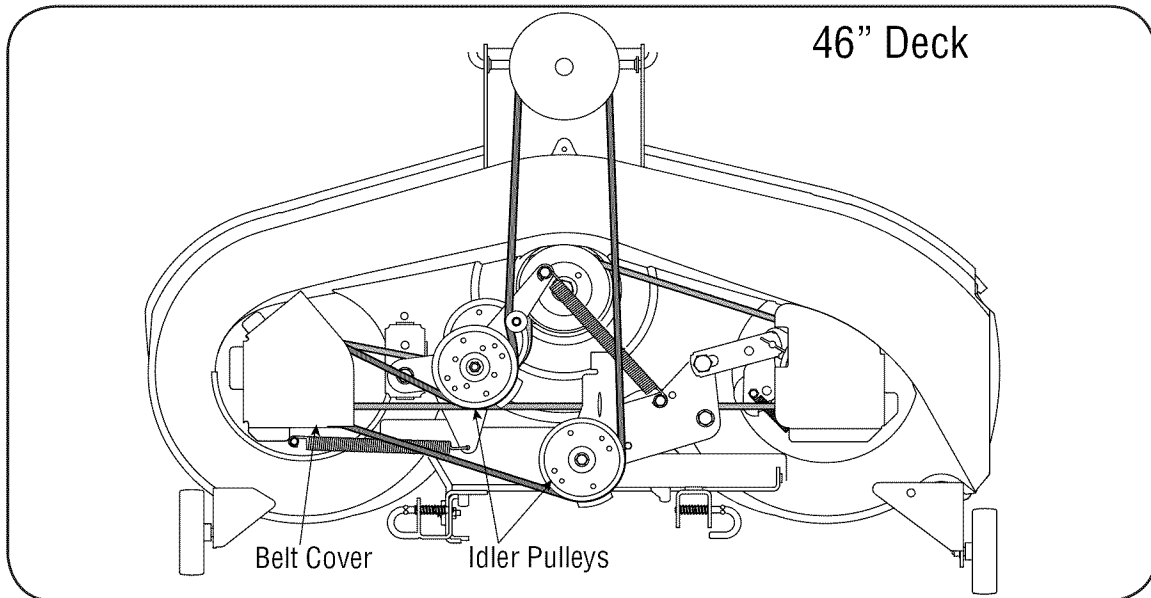

Figure 27

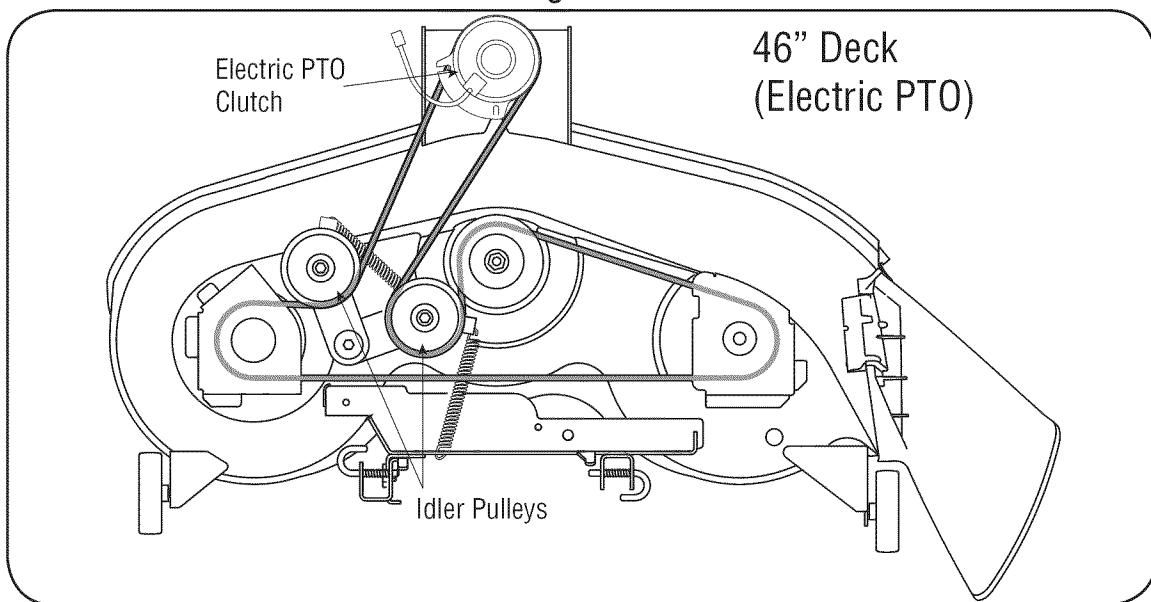

Figure 28

7

Off-Season Storage/ Attachments



WARNING

Drain fuel only into an approved container outdoors, away from an open flame. Allow engine to cool. Extinguish cigarettes, cigars, pipes, and other sources of ignition prior to draining fuel.

Never store the machine or fuel container indoors where there is an open flame, spark or pilot light such as on water heater, furnace, clothes dryer or other gas appliance.

Clean and lubricate the tractor as instructed in **Section 6: MAINTAINING YOUR LAWN TRACTOR** on page 19 of this manual before storing for an extended period.



WARNING: Drain fuel only into an approved container outdoors, away from an open flame. Allow engine to cool. Extinguish cigarettes, cigars, pipes, and other sources of ignition prior to draining fuel.

Follow the instructions in the **Service, Storage & Specifications** section of the Engine Operator/Owner Manual for proper engine care prior to storing your tractor.



WARNING: Never store the machine or fuel container indoors where there is an open flame, spark or pilot light such as on water heater, furnace, clothes dryer or other gas appliance.

Attachments & Accessories

The following attachments and accessories are compatible for Model Series 605 Lawn Tractors. See the retailer from which you purchased your tractor, an authorized MTD Service Dealer or phone (800) 800-7310 for information regarding price and availability.

NOTE: Model Series 605 Lawn Tractors are NOT designed for use with any type of ground-engaging attachments (e.g. tiller or plow). Use of this type of equipment WILL void the tractor's warranty.

MODEL	DESCRIPTION
OEM-190-032	42-inch Two-stage Snow Thrower
OEM-190-116	42-inch Deck Mulch Kit
OEM-190-118	46-inch Deck Mulch Kit
OEM-190-180	Twin Bagger Grass Collector (for 42-inch Decks)
OEM-190-182	Twin Bagger Grass Collector (for 46-inch Decks)
OEM-190-218	Rear Wheel Weight Kit
OEM-190-607*	Deluxe Tractor Sunshade
OEM-190-658	Tire Chains, 20 x 8 Tires
OEM-190-672	Grille Guard (mounts on front of tractor)
OEM-190-833	46-inch Front Dozer Blade

* Not compatible with tractors equipped with a Grass Collector

8

Safety Labels



WARNING

This symbol points out important safety instructions which, if not followed, could endanger the personal safety and/or property of yourself and others. Read and follow all instructions in this manual before attempting to operate this machine. Failure to comply with these instructions may result in personal injury. When you see this symbol.

HEED ITS WARNING!

Your Responsibility

Restrict the use of this power machine to persons who read, understand and follow the warnings and instructions in this manual and on the machine.

⚠ DANGER
ROTATING BLADES CAUSE SERIOUS INJURY OR DEATH

- DO NOT MOW WHEN CHILDREN OR OTHERS ARE AROUND
- NEVER CARRY CHILDREN EVEN WITH BLADE(S) OFF.
- LOOK DOWN AND BEHIND BEFORE AND WHILE BACKING
- MOWING IN REVERSE IS NOT RECOMMENDED

⚠ WARNING
TO AVOID SERIOUS INJURY OR DEATH

- GO UP AND DOWN SLOPES, NOT ACROSS.
- AVOID SUDDEN TURNS.
- DO NOT OPERATE THE UNIT WHERE IT COULD SLIP OR TIP.
- IF MACHINE STOPS GOING UP HILL, STOP BLADE(S) AND BACK DOWNHILL SLOWLY.
- KEEP SAFETY DEVICES (GUARDS, SHIELDS, AND SWITCHES, ETC.) IN PLACE AND WORKING.
- REMOVE OBJECTS THAT COULD BE THROWN BY THE BLADE(S).
- KNOW LOCATION AND FUNCTION OF ALL CONTROLS.
- BE SURE BLADE(S) AND ENGINE ARE STOPPED BEFORE PLACING HANDS OR FEET NEAR BLADE(S).
- BEFORE LEAVING OPERATOR'S POSITION, DISENGAGE BLADE(S), ENGAGE PARKING BRAKE, SHUT OFF AND REMOVE KEY.

READ OPERATOR'S MANUAL

OPTIONAL ATTACHMENTS

65W-100-110	36" Bagger Kit	65W-100-110	42" Front Loader Bucket
65W-100-110	36" Mulcher Kit	65W-100-110	42" Snowblower Attachment
65W-100-110	48" Bagger Kit	65W-100-110	Tire Chains, 2x20 Tires
65W-100-110	48" Mulcher Kit	65W-100-210	Rear Weight Kit
65W-100-100	37" Bagger Kit	65W-100-172	Front Bumper
65W-100-100	37" Mulcher Kit		Tractor Seatbelt

START UP

- DISENGAGE BLADE(S), (POWER TAKE OFF)
- ENGAGE THE TRACTOR'S PARKING BRAKE.
- SET THROTTLE TO FAST "RABBIT" POSITION AND PULL CHOKE KNOB OUT.
- TURN KEY TO START ENGINE. AFTER START RELEASE KEY & DEACTIVATE CHOKE.

OPERATING MODES

NORMAL MOWING:
YOU MUST DISENGAGE BLADE(S), (POWER TAKE OFF) BEFORE TRAVELING IN REVERSE.

REVERSE CAUTION MODE:

- TURN KEY TO REVERSE CAUTION MODE POSITION.
- PRESS REVERSE PUSH BUTTON. (RED INDICATOR LIGHT "ON") WHEN RED LIGHT IS "ON" MACHINE CAN BE OPERATED IN REVERSE WITH MOVED BLADES ENGAGED. IMPORTANT! MOWING IN REVERSE IS NOT RECOMMENDED.
- AFTER RESUMING FORWARD OPERATION, RETURN KEY TO "NORMAL MOWING" POSITION.

NOTE: IN BOTH MODES, WHEN OPERATOR LEAVES SEAT, ENGINE WILL STOP UNLESS PARKING BRAKE IS SET AND BLADES ARE DISENGAGED.

PARKING BRAKE

PRESS, PUSH PARKING BRAKE LEVER DOWN AND RELEASE PEDAL TO LOCK.

CRUISE CONTROL

PRESS SPEED CONTROL PEDAL TO DEPRESS SPEED CONTROL LEVER DOWN AND RELEASE PEDAL, PRESS BRAKE OR SPEED CONTROL TO RELEASE.

SPEED CONTROL PEDAL

PRESS PEDAL DOWN TO INCREASE SPEED.

⚠ DANGER

AVOID SERIOUS INJURY OR DEATH

- KEEP HANDS AND FEET AWAY FROM ROTATING PARTS
- REMOVE OBJECTS THAT CAN BE THROWN BY THE BLADE IN ANY DIRECTION. WEAR SAFETY GLASSES.
- DO NOT MOW WHEN CHILDREN OR OTHERS ARE AROUND. NEVER CARRY CHILDREN EVEN WITH BLADES OFF.
- USE EXTRA CAUTION ON SLOPES. DO NOT MOW SLOPES GREATER THAN 15°. MOW UP AND DOWN NOT ACROSS. AVOID SUDDEN TURNS. USE LOW SPEED.

READ OPERATOR'S MANUAL. KEEP SAFETY DEVICES IN PLACE AND WORKING.

S30018 MAX 16

⚠ DANGER

KEEP HANDS AND FEET AWAY. DO NOT OPERATE MOWER UNLESS CHUTE DEFLECTOR OR ENTIRE GRASS CATCHER IS IN ITS PROPER PLACE.

ASSEMBLE CHUTE DEFLECTOR TO THIS UNIT BEFORE OPERATING.

S300503

9

Trouble Shooting



For repairs beyond the minor adjustments listed here, contact an authorized service dealer.

Problem	Cause	Remedy
Engine fails to start	<ol style="list-style-type: none"> 1. PTO engaged. 2. Spark plug wire(s) disconnected. 3. Fuel tank empty or stale fuel. 4. Choke not activated. 5. Faulty spark plug. 6. Blocked fuel line. 7. Engine flooded. 8. Parking brake not engaged. 9. Throttle control lever not in correct starting position. 	<ol style="list-style-type: none"> 1. Place PTO knob (or lever) in disengaged (OFF) position. 2. Connect wire(s) to spark plug(s). 3. Fill tank with clean, fresh gasoline. 4. Pull out the CHOKE control (if so equipped) or place the throttle control in CHOKE position. 5. Clean, adjust gap, or replace. 6. Clean fuel line or replace fuel filter, if so equipped. 7. Crank engine with throttle in FAST position. 8. Engage parking brake. 9. Place throttle lever to FAST position.
Engine runs erratic	<ol style="list-style-type: none"> 1. Unit running with CHOKE applied. 2. Spark plug wire(s) loose. 3. Blocked fuel line or stale fuel. 4. Vent in gas cap plugged. 5. Water or dirt in fuel system. 6. Dirty air cleaner. 	<ol style="list-style-type: none"> 1. Push CHOKE control (if so equipped) in, or move the throttle control out of the CHOKE position. 2. Connect and tighten spark plug wire(s). 3. Clean fuel line; fill tank with clean, fresh (less than 30 days old) gasoline. Replace fuel filter, if so equipped. 4. Clear vent or replace if damaged. 5. Drain fuel tank. Refill with fresh fuel. 6. Replace air cleaner cartridge/element or clean pre-cleaner, if so equipped.

Problem	Cause	Remedy
Engine overheats	<ol style="list-style-type: none"> 1. Engine oil level low. 2. Air flow restricted. 	<ol style="list-style-type: none"> 1. Fill crankcase with proper oil. 2. Clean grass clippings and debris from around the engine's cooling fins and blower housing.
Engine hesitates at high RPM	<ol style="list-style-type: none"> 1. Spark plug(s) gap too close. 	<ol style="list-style-type: none"> 1. Remove spark plug(s) and reset the gap.
Idles poorly	<ol style="list-style-type: none"> 1. Spark plug(s) fouled, faulty or gap too wide. 2. Dirty air cleaner. 	<ol style="list-style-type: none"> 1. Replace spark plug(s). Set plug(s) gap. 2. Replace air cleaner cartridge/element or clean pre-cleaner, if so equipped.
Excessive Vibration	<ol style="list-style-type: none"> 1. Cutting blade loose or unbalanced. 2. Damaged or bent cutting blade. 	<ol style="list-style-type: none"> 1. Tighten blade and spindle. Balance blade. 2. Replace blade.
Mower will not mulch grass (If Equipped)	<ol style="list-style-type: none"> 1. Engine speed too low. 2. Wet grass. 3. Excessively high grass. 4. Dull blade. 	<ol style="list-style-type: none"> 1. Place throttle control in FAST (rabbit) position. 2. Do not mow when grass is wet; wait until later to cut. 3. Mow once at a high cutting height, then mow again at desired height or make a narrower cutting path. 4. Sharpen or replace blade.
Uneven cut	<ol style="list-style-type: none"> 1. Deck not balanced properly. 2. Dull blade. 3. Uneven tire pressure. 	<ol style="list-style-type: none"> 1. Perform side-to-side deck adjustment. 2. Sharpen or replace blade. 3. Check tire pressure in all four tires.

9

Trouble Shooting



For repairs beyond the minor adjustments listed here, contact an authorized service dealer.

Model Series 605

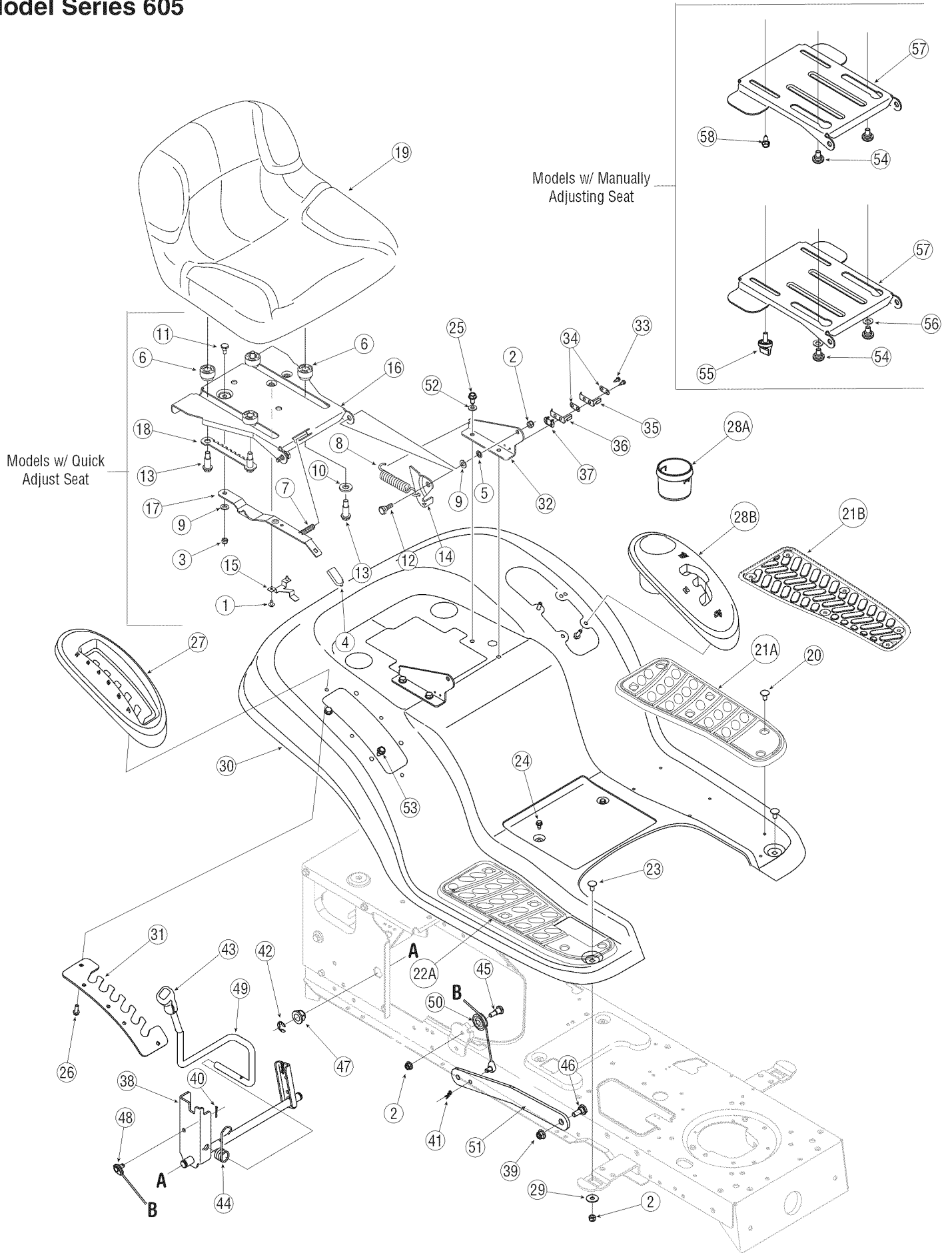

Ref. No.	Part No.	Description
1	710-1268†	Screw, #10-16 x.375
2	712-04063	Nut, Flange Lock, 5/16-18, GrF
3	712-3027†	Nut, Flange Lock, 1/4-20
4	720-0309A†	Seat Adjuster Grip
5	726-0201†	Nut, Speed,.3125 ID
6	731-04074†	Spacer
7	732-0499†	Compression Spring,.41 x 1.5
8	732-1184	Spring, Extension,.84 Dia. x 4.6
9	736-0275†	Wash, Flat,.344 x.688 x.065
10	736-3019†	Wash, Flat,.531x 1.062 x.134
11	738-0137A†	Screw, Shld,.340 x.285, 1/4-20
12	738-0296	Screw, Shoulder,.437 x.268
13	738-0966†	Screw, Should,.50 x.925, 3/8-16
14	783-0209D	Seat Bracket, Lift
15	783-0611†	Seat Stop
16	783-0738C†	Seat Pivot Bracket
17	783-0739A†	Seat Adjustment Lever
18	783-0753†	Seat Adjustment Selector
19	757-04011C	Medium Back Seat, Yellow
20	726-3046	Ratchet Clip
21a	735-0657	LH Foot Pad, Rubber
21b	735-0673	LH Foot Pad, Rubber
22a	735-0656	RH Foot Pad,Rubber
22b	735-0672	RH Foot Pad,Rubber(not shown)
23	710-0451	Bolt, Carriage, 5/16-18,.75, Gr1
24	710-0599	Screw, 1/4-20, 0.500
25	710-0604A	Screw, 5/16-18, 0.625
26	710-0895†	Screw, 1/4-15, 0.750
27	731-1990†	Cover, Lift Lever
28a	731-04591A	Cup Holder
28b	731-2104C	Cover, w/ Cup Holder
29	736-3078	Washer, Flat,.344 x 1.0 x.063
30	783-04314A	Fender (Model X605G)

Ref. No.	Part No.	Description
	783-04333A	Fender
31	783-1010A	Plate, Deck, Lift (Model X605G)
	783-0677B	Adjust. Brkt., Lift
32	783-1489A	Mounting Bracket, Seat
33	710-0227	Screw, #8-18 x.50
34	726-0279	Plate, Insulator
35	725-1303	Spring Switch, Outer
36	725-1439	Spring Switch, Inner
37	726-0278	Plate, Insulator Boss
38	683-04079	Shaft Assembly, Lift
39	712-04065	Nut, Flange Lock, 3/8-16, GrF
40	714-0104	Pin, Cotter,.072 Dia. x 1.13
41	714-0111	Pin, Cotter, 3/32, 1.0
42	716-0106A	Ring, E Type,.625 Dia.
43	720-0311	Grip, Handle, 1/2
44	732-0874	Spring, Torsion
45	738-0138A	Screw, 5/16-18 x.620 Gr2
46	738-04130	Scr.,Shldr, .625 x.165,(42" Deck)
	738-0380	Screw, Shld,.50 x.27, (46" Deck)
47	741-0225	Bearing, Hex Flange
48	746-0968	Cable, Lift, 16.16
49	747-04155	Handle, Lift
50	756-1154	Pulley, Roller
51	783-04711	Arm, Lift - LH (42" Deck)
	783-04494	Arm, Lift - RH (42" Deck)
	783-0678A	Arm, Lift- LH & RH (46" Deck)
52	736-0607	Lock Washer, 5/16
53	710-0726	Screw, 5/16-12
54	738-04012A†	Shoulder Screw
55	720-04061†	Knob, 3/8-16
56	736-0300†	Flat Washer, .406 x .875 x .059
57	783-04081A†	Seat Pivot Bracket, Manual Adj.
58	710-0870†	Hex Head Washer Screw, 3/8-16

† If Equipped

10

Illustrated Parts List



To order replacement parts, call the Customer Service Line at 1-800-800-7310, or visit www.yardman.com.

NOTE: Tractor features vary by model. NOT all parts listed above and pictured on the previous page are standard equipment.

Model Series 605

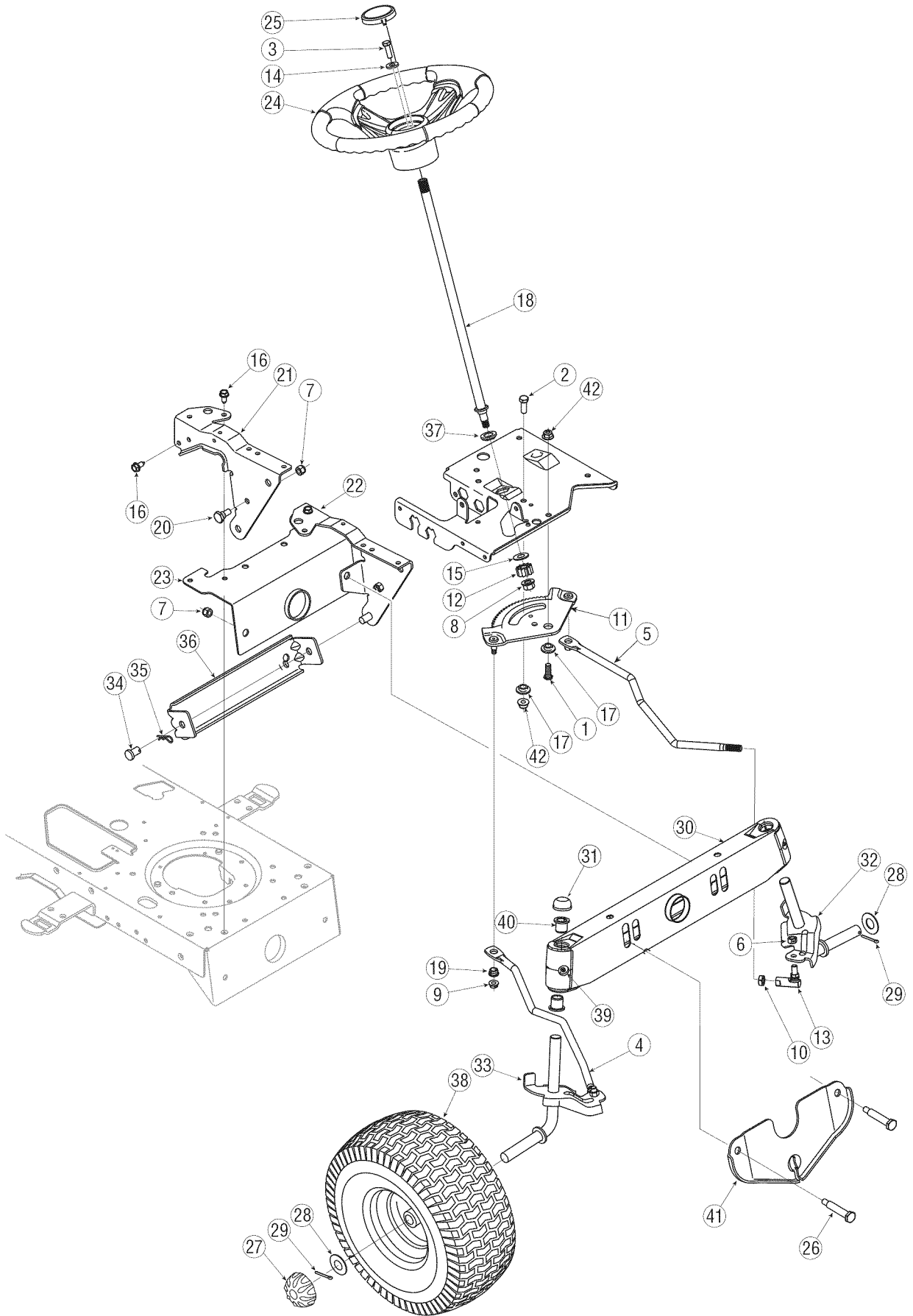

Ref. No.	Part No.	Description	Ref. No.	Part No.	Description
1	710-04095	Hex Screw, 3/8-16, 1.00, Gr5		731-04039	Steering Wheel Cap, No Sprig
2	710-0514	Hex Screw, 3/8-16, 1.00, Gr5	26	738-04128	Shoulder Screw, .5 x 2.380, 3/8-16
3	710-0643	Hex Screw, 5/16-18, 1.00, Gr5		738-1011A	Shoulder Screw, .5 x 2.2, 3/8-16
4	711-1408	Link, Drag, RH	27	734-2290A	Deluxe Hub Cap
5	711-1409A	Link, Drag, LH	28	736-0316	Flat Washer, .78 x 1.589 x .06
6	712-0214	Nut, Hex Lock, 3/8-24	29	714-04039	Cotter Pin, 5/32 x 1.25
7	712-04065	Nut, Flange Lock, 3/8-16, Grf	30	683-0128B	Stamped Pivot Bar
8	712-0459	Nut, Flange Lock, 7/16-20		719-04105	Cast Iron Pivot Bar
9	712-3004A	Nut, Flange Lock, 5/16-18, Gr5	31	726-0341	Push Cap
10	712-0240	Nut, Jam, 7/16-20, Gr2	32	638-04006	LH Axle Assembly, .750 (42" Deck)
11	717-1550E	Gear, Steering, 11/90 Ratio		638-04003	LH Axle Assembly, .750 (46" Deck)
12	717-1554	Gear, Pinion, Steering	33	638-04005	RH Axle Assembly, .750 (42" Deck)
13	723-0448A	Ball Joint, 7/16-20, Lock		638-04004	RH Axle Assembly, .750 (46" Deck)
14	736-3004	Washer, Flat, .406 x .875 x .105	34	711-0332†	Pin, Clevis, .50 x .78
15	736-3084	Washer, Flat, .51 x 1.12 x .06	35	714-04023†	Cotter Pin, Internal, .080 x 1.5625
16	710-1260A	Screw, 5/16-18, 0.750	36	783-0720A†	Adjustment Bracket, Front
17	738-04154	Spacer, Shoulder, .38 x 1.00 x .31	37	741-0656A	Hex Flange Bearing
18	738-1001A	Shaft, Steering, .625 OD x 24.25	38	634-04086	Wheel Assembly Complete, 15 x 6
19	741-0475	Plastic Bushing .380 ID		734-1731	Tire Only 15 x 6 x 6
20	738-0143	Screw, Shoulder, .498 x .340		634-04081	Rim Only w/ Valve Stem
21	783-0726E	Pivot Bracket, Support RH	39	731-1291A	Pivot Bar End Cap
22	783-0727D	Pivot Bracket, Support LH	40	741-0660A	Flange Bearing, .760 x .941 x 1.0
23	783-0728	Pivot Bracket, Bar	41	783-04568†	Front Deck Hanger Bracket
24	631-04028	Steering Wheel	42	712-0431	Flange Lock Nut, 3/8-16
25	731-04040	Steering Wheel Cap, Sprig			

† If Equipped

10

Illustrated Parts List



To order replacement parts, call the Customer Service Line at 1-800-800-7310, or visit www.yardman.com.

NOTE: Tractor features vary by model. NOT all parts listed above and pictured on the previous page are standard equipment.

Model Series 605

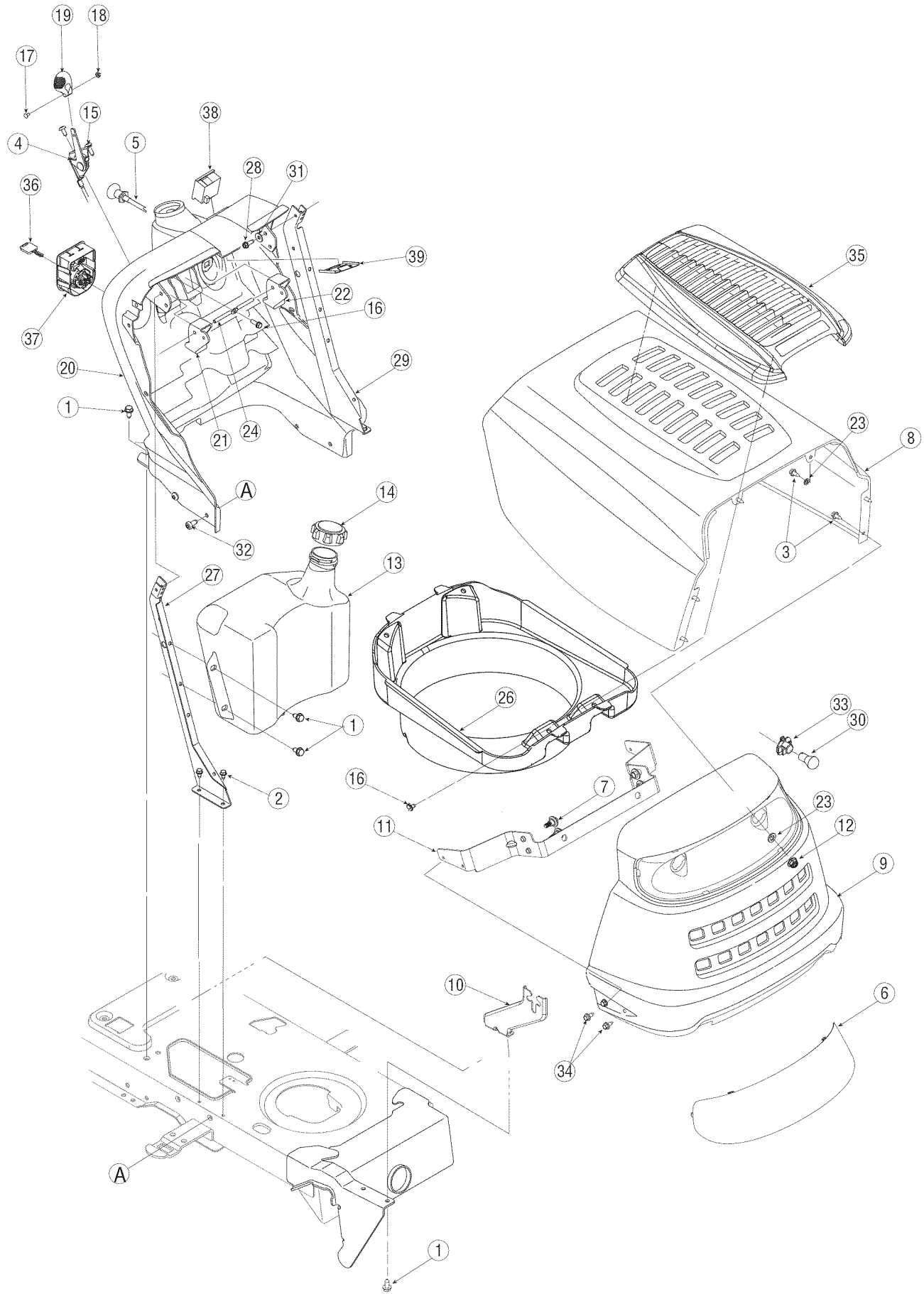

Ref. No.	Part No.	Description
1	710-0726	Screw, 5/16-12 x.750
2	710-0599	Self-tapping Screw, 1/4-20 x.5
3	710-0751	Hex Cap Screw, 1/4-20 x.62
4	746-1086	Throttle Control
	746-1084	Throttle/Choke Control
5	746-1085A	Choke Control
	731-1999	Choke Plug
6	731-04949	Headlight Lens
7	738-04091	Shoulder Screw, .43 x.29
8	783-04551	Hood, 1 Style
9	783-04552	Grill, 1 Style
10	783-04578	Pivot Bracket - RH
	783-04577	Pivot Bracket - LH
11	783-04621	Grill Pivot Bracket
12	712-04064	Flange Lock Nut, 1/4-20
13	751-0658E	Fuel Tank, Three Gallon
	751-0659C	Fuel Tank, Two Gallon
14	751-0603	Fuel Cap
15	710-1017	Screw, 1/4-14 x.625
16	710-0895	Self-tapping Screw, 1/4-15 x.75
17	710-3217	Truss Phillips Screw, #8-32 x.375
18	712-0142	Hex Nut, #8-32
19	731-1857	Throttle Control Knob
20	731-05005A	Dash Panel (Electric PTO)

Ref. No.	Part No.	Description
	731-05001B	Dash Panel (Manual PTO)
21	731-04215	Cruise Control Button
22	731-04217	Parking Brake Button
23	736-0176	Flat Washer, .265 x .938 x 1.20
24	747-1196	Brake/Cruise Pivot Rod
25	629-04083†	Headlight Wire Harness
26	731-05566	Hood Plenum
27	783-04908	RH Dash Support Plate
28	710-0642	Self-tapping Screw, 1/4-20 x.75
29	783-04909	LH Dash Support Plate
30	725-0963	Lamp
31	736-0270	Bell Washer, .265 x.75 x.062
32	710-1611B	Screw, 5/16-18 x.75
33	725-1649	Headlight Socket
34	710-1652	Hex Index Screw, 1/4-20 x.625
35	731-05522	Hood Cover
36	725-1745	Ignition Key w/ plastic cover
	725-1744	Ignition Key w/o plastic cover
37	725-04227A	Ignition Switch
38	725-04036B	Systems Ind. Monitor w/ Hr. Meter
—	725-04336†	Wire Harness (Electric PTO)
—	725-04339†	Wire Harness (Manual PTO)
39	725-1752	Electric PTO Switch

† Not Shown

10

Illustrated Parts List



To order replacement parts, call the Customer Service Line at 1-800-800-7310, or visit www.yardman.com.

NOTE: Tractor features vary by model. NOT all parts listed above and pictured on the previous page are standard equipment.

Model Series 605

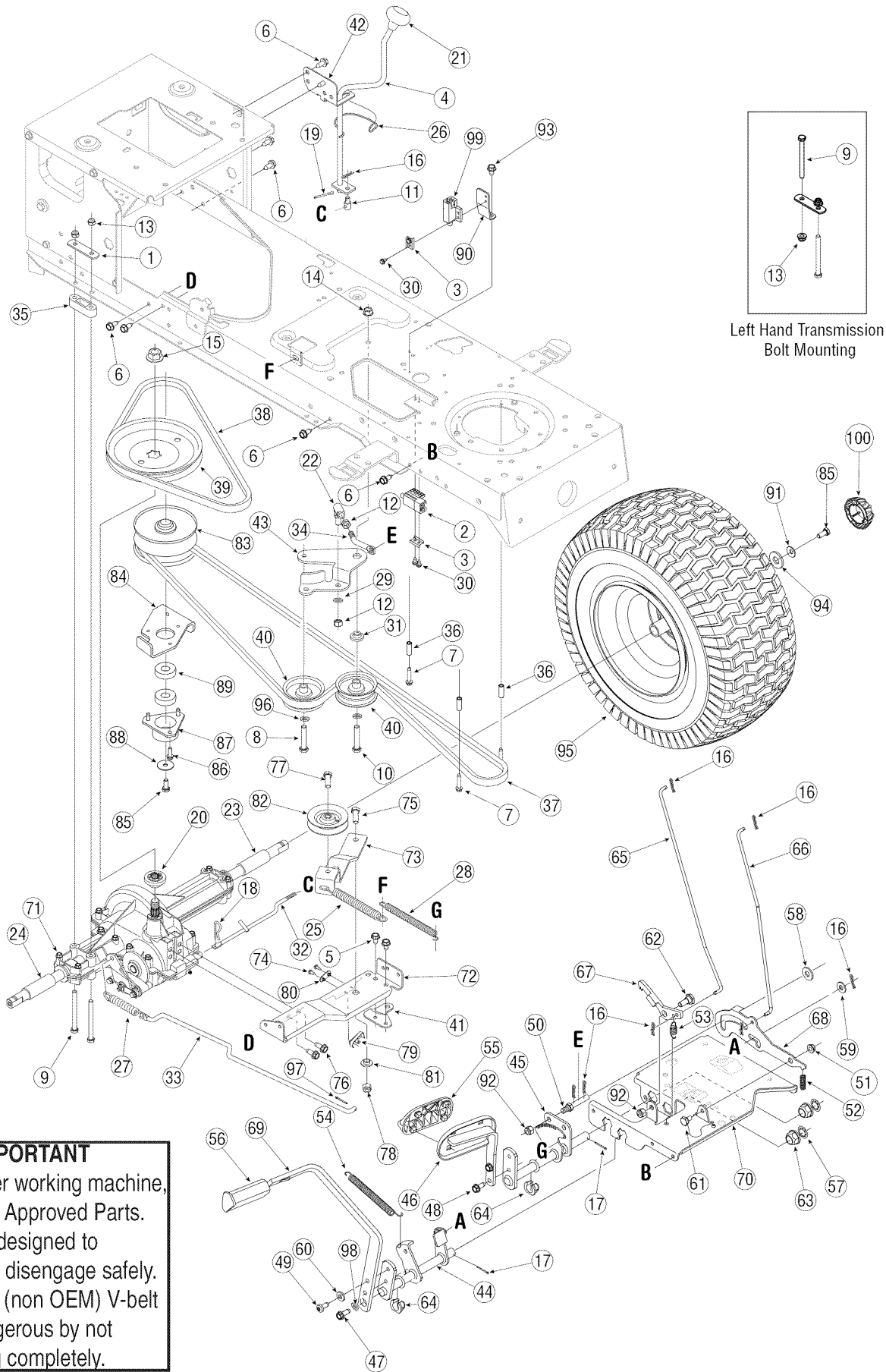

Left Hand Transmission Bolt Mounting

IMPORTANT
 For a proper working machine, use Factory Approved Parts. V-belts are designed to engage and disengage safely. A substitute (non OEM) V-belt can be dangerous by not disengaging completely.

Ref. No.	Part No.	Description
1	17840	Mounting Bracket, Transaxle
2	725-04039	Switch, Interlock
3	17962	Plate, Switch
4	647-04020	Lever Assembly, Shift
5	710-0607	Screw, 5/16-18, 0.500
6	710-0726	Screw, 5/16-12, 0.750
7	710-0809	Screw, 1/4-20, 1.250
8	710-1007	Screw, Sems, 3/8-16, 1.500
9	710-1266	Screw, 5/16-18, 3.50, Gr5
10	710-3144	Screw, 3/8-16, 2.00, Gr5
11	711-0736	Adjustment Ferrule 1/4-20 x 1.
12	712-0241	Nut, Hex, 3/8-24, Gr5
13	712-04063	Nut, Flange Lock, 5/16-18, GrF
14	712-0431	Nut, Flange Lock, 3/8-16, GrF
15	712-0700	Nut, Flange, 9/16-18, Gr2
16	714-0104	Pin, Cotter,.072 Dia. x 1.13
17	714-0111	Pin, Cotter, 3/32, 1.0
18	714-0209	Cotter Pin, Internal,.125 Dia.
19	714-0470	Pin, Cotter, 1/8 x 1.25
20	718-0758A	Pulley Hub, 5/8 Spline
21	720-04028	Knob, Shift
22	723-3018	Ball Joint
23	731-04602	Sleeve,.758 x.821 x 3.3125
24	731-04604	Sleeve,.758 x.821 x 2.4375
25	732-0384	Spring, Extension,.62 Dia x 6.12
26	732-0525	Spring Clip, Shifter
27	732-0716C	Spring, Extension,.59 OD x 4.00
28	732-0963	Spring, Extension,.50 Dia x 6.37
29	736-0169	Washer, Lock, 3/8
30	710-0224	Screw, #10-16,.50
31	738-0372B	Spacer, Shoulder, 1.00 x.38 x.38
32	747-04146B	Rod, Shift
33	747-04164	Rod, Brake
34	747-1127	Idler Rod, Adjustable, 3/8
35	748-0334	Spacer,.68
36	750-0566A	Spacer,.260 x.372 x 1.030
37	754-0467	Belt, V-Type
38	754-0468	Belt, V-Type
39	756-04002	Pulley, V-Type, 7.25 Dia.
40	756-04224	Idler Pulley, Flat 2.75 OD
41	783-04283	Bracket, Shift

Ref. No.	Part No.	Description
42	783-04360	Bracket, Shift, F-N-R
43	783-04442	Idler Bracket, Center Double
44	647-0031B	Control Assembly, Brake
45	647-0032A	Control Assembly, Speed
46	683-0266	Pedal Assembly
47	710-0650	Screw, 5/16-18, 0.875
48	710-1260A	Screw,5/16-18, 0.750
49	710-1611B	Screw, 5/16-18, 0.750
50	711-04159B	Pin, 3/8-16 x 2.68
51	712-3004A	Nut, Flange Lock, 5/16-18, Gr5
52	732-0335	Spring, Compression,.405 x 1.17
53	732-0955	Spring, Extension,.50 OD x 1.41
54	732-0963	Spring, Extension,.50 OD x 6.37
55	735-0662	Pad
56	735-3049	Pad, Brake
57	736-0187	Washer, Flat,.64 x 1.24 x.06, Ht
58	736-0262	Washer, Flat,.385 x.870 x.092
59	736-0300	Washer, Flat,.406 x.875 x.059
60	736-3008	Washer, Flat,.344 x.750 x.120
61	738-0155	Screw, Shoulder.437 Dia x.162
62	738-0380	Screw, Shoulder,.50 x.27 Lg,
63	741-0225	Bearing, Hex Flange
64	741-3065B	Split Bearing, Hex Flange
65	747-04093	Rod, Brake Lock
66	747-04096	Rod, Cruise Control
67	748-04039B	Latch, Cruise Control
68	783-0732A	Bracket, Lockout
69	783-0773A	Ped, Brake
70	783-04612	Bracket, Steering Support
71	618-04034	Transmission, Single Speed
72	683-04055A	Bracket Assembly, Torque
73	683-04130	Bracket, Idler
74	710-0227	Screw, #8-18 x.50
75	710-0514	Screw, 3/8-16, 1.00
76	710-0604A	Screw, 5/16-18,.625
77	710-1315	Screw, 3/8-16, 1.250
78	712-0130	Nut, Lock, 3/8-16, Nylon
79	725-1644	Switch Spring, Short
80	726-0320	Plate, Insulator
81	750-04294	Spacer, Shoulder
82	756-04209	Pulley, V-Type, 3.06

Continued on next page

10

Illustrated Parts List



To order replacement parts, call the Customer Service Line at 1-800-800-7310, or visit www.yardman.com.

10

Illustrated Parts List



To order replacement
parts, call the Customer
Service Line at
1-800-800-7310,
or visit
www.yardman.com.

Model Series 605

Ref. No.	Part No.	Description
83	656-04015	Pulley Ass'y, Variable Speed
84	683-04129	Bracket, Pulley
85	710-0627	Screw, 5/16-24,.750
86	710-1652	Screw, 1/4-20,.625
87	718-04012	Cup, Bearing
88	736-0362	Washer, Flat
89	741-0600	Ball Bearing
90	783-04722	Switch Bracket, Parking Brake
91	736-0242	Washer, Bell,.340 x.872 x.060
92	712-04065	Nut, Flange Lock, 3/8-16, GrF
93	710-0599	Screw, 1/4-20 x.500
94	736-0430	Flat Washer,.350 x 1.59 x.062
95	634-0104	Wheel Assy Comp, 20 x 8 x 8
	734-1730	Tire Only 20 x 8 x 8
	734-0603A	Rim Only w/ Valve Stem
96	736-3010	Flat Washer, .407 x .812 x .135
97	714-0507	Pin, Cotter, 3/32 x .750
98	736-0119	Lock Washer, 5/16
99	725-3167	Switch
100	731-2290A	Hub Cap

NOTE: Tractor features vary by model. NOT all parts listed above and pictured on the previous page are standard equipment.

Kohler Courage

Kohler V-Twin

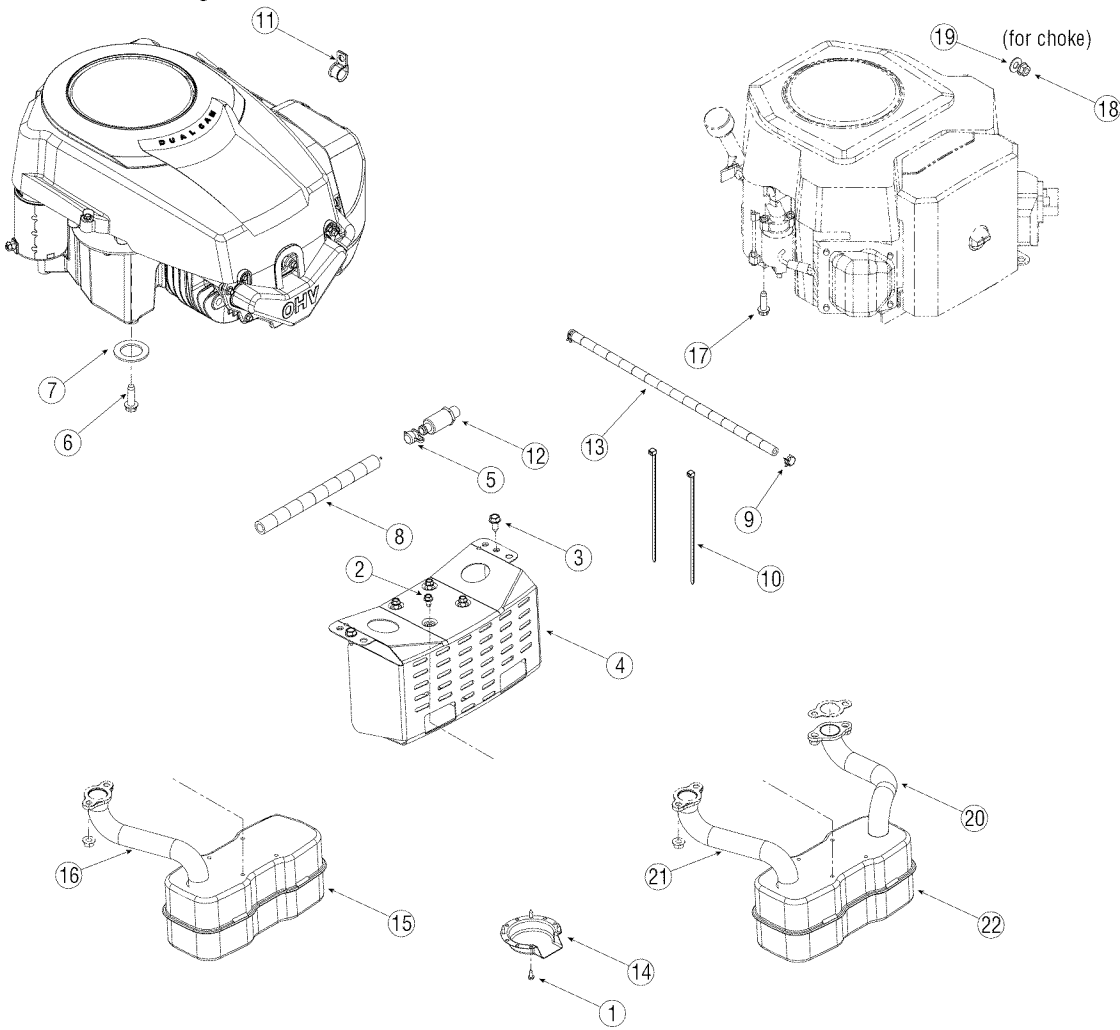

10

Illustrated Parts List



To order replacement parts, call the Customer Service Line at 1-800-800-7310, or visit www.yardman.com.

Ref. No.	Part No.	Description
1	710-0227	AB Screw #8-18 x 0.5
2	710-0599	TT Screw 1/4-20 x 0.5
3	710-0726	AB Screw 5/16-12 x 0.5
4	783-0615D	Muffler Bracket
5	751-3142	Oil Drain Cap
6	710-0654A	TT Screw 3/8-16 x 1.00
7	736-0277	Flat Washer, 1.031 x 1.620 x .095
8	751-3141	Oil Drain Extension Hose
9	726-0205	Hose Clamp
10	725-0157	Cable Tie
11	726-0272	Clamp

Ref. No.	Part No.	Description
12	751-3140	Oil Drain Valve
13	751-10349	Fuel Line Hose
14	751-0564A	Muffler Deflector
15	751-0617B	Single Inlet Muffler
16	751-10047	Exhaust Pipe
17	710-1315	Screw, 3/8-16 x 1.250
18	712-3005	Flange Lock Nut, 3/8-16
19	736-0300	Flat Washer, .406 x .875 x .059
20	751-0644B	LH Exhaust Pipe
21	751-0645A	RH Exhaust Pipe
22	751-0805A	Dual Inlet Muffler

NOTE: Tractor features vary by model. NOT all parts listed above and pictured on the previous page are standard equipment.

Model Series 605 (42" Deck - Manual PTO)

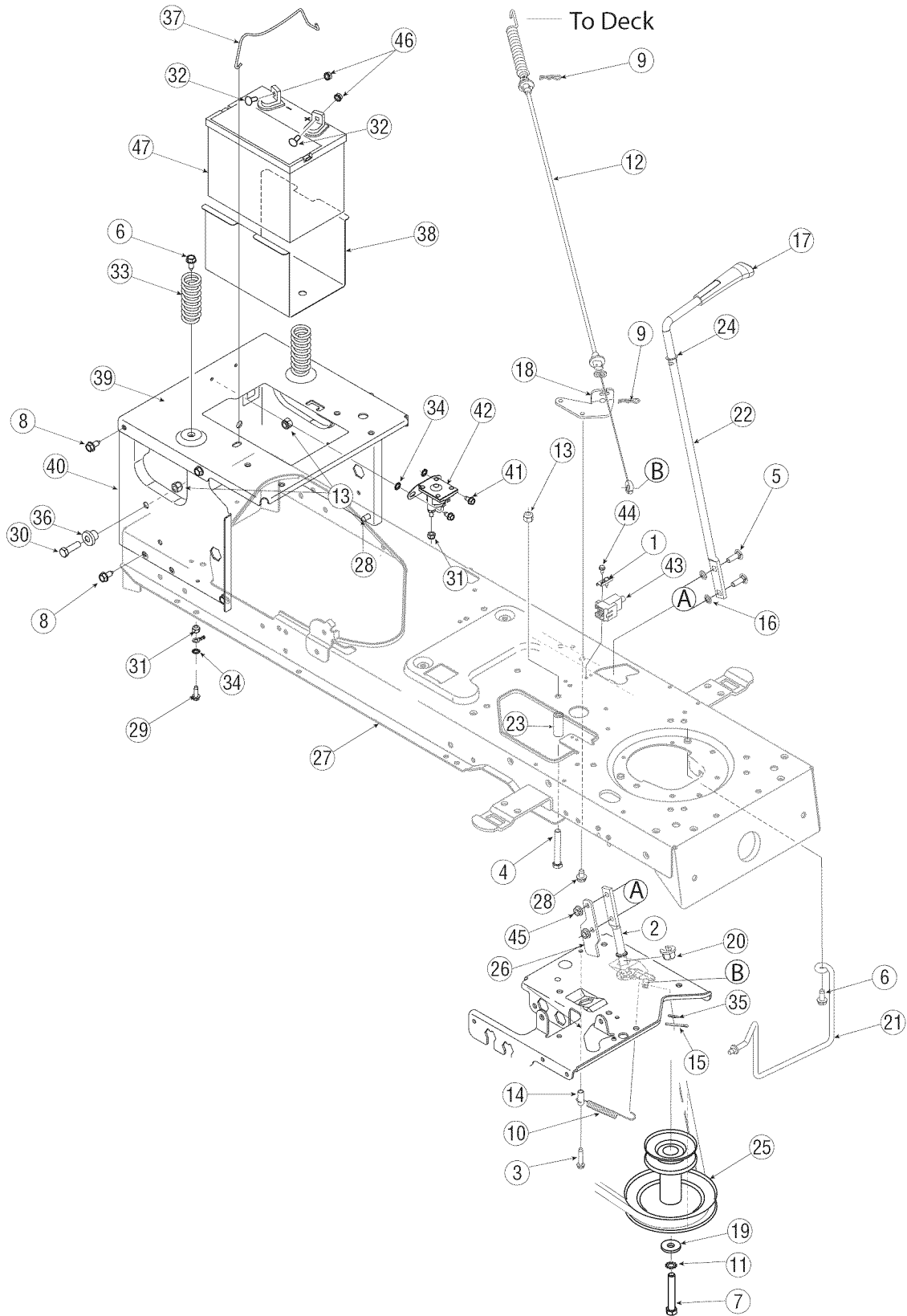

Ref. No.	Part No.	Description
1	17962	Plate, Switch
2	647-04036	Lever Assembly, Engagement
3	710-0778	Screw, 1/4-20 x 1.500
4	710-0859	Screw, 3/8-16, 2.50
5	710-0276	Screw, Carriage, 5/16-18, 1.00
6	710-1260A	Screw, 5/16-18 x.750
7	710-3157A	Screw, 7/16-20, 3.25, Gr5
8	710-0726	Screw, 5/16-12, 0.750
9	714-0145	Click Pin
10	732-04248	Extension Spring,.38OD x 3.9LG
11	736-0171	Lock Washer, 7/16
12	746-04092	Deck Engagement Cable
13	712-04065	Nut, Flange Lock, 3/8-16, GrF
14	750-0566A	Spacer,.260 x.372 x 1.030LG
15	714-0470	Pin, Cotter, 1/8 x 1.25
16	726-0201	Nut, Speed,.3125 ID
17	731-2111A	Knob, PTO
18	783-04590A	Cable Bracket
19	736-0322	Washer, Flat,.450 x1.250 x.164
20	741-0708	Bearing, Flange, .500 ID
21	747-04307	Keeper Rod, Belt
22	747-04470	Engagement Handle, Deck
23	748-0415B	Spacer,.385 ID x.635 OD x 1.54
24	736-0108	Flat Washer, .510 x .750 x .033

Ref. No.	Part No.	Description
25	756-04196	Pulley, Engine, 3.39 x 6.12 Dia.
26	783-0744A	Stop Bracket, Engagement
27	683-04173	Frame Assembly, Lower
28	710-0607	Screw, 5/16-18, 0.500
29	710-0642	Screw, 1/4-20, 0.750
30	710-3005	Screw, 3/8-16, 1.25, Gr5
31	712-04064	Nut, Flange Lock, 1/4-20, GrF
32	710-0703	Screw, Carriage, 1/4-20,.75
33	732-04035	Spring, Compr. , 1.28 OD x 3.125
34	736-0222	Washer, Lock, 1/4, External
35	736-0275	Flat Washer, .344 x .688 x .065
36	738-04058	Spacer, Shoulder,.38 x 1.0 x.70
37	747-04121A	Hold Rod, Battery
38	783-0349	Battery Tray
39	783-04329A	Seat Bracket, Frame
40	783-04809	Frame, Upper
41	710-0599	Screw, 1/4-20, 0.50
42	725-1426A	Solenoid, 12V, 100 Amp
43	725-04039	Switch, Interlock
44	710-0224	Screw, #10-16,.50
45	712-3004A	Nut, Flange, Lock Nut, 5/16-18
46	712-0271	Nut, Sems, 1/4-20
47	725-1737A	Battery, 190 CCA
	725-1750A	Battery, 235 CCA

10

Illustrated Parts List



To order replacement parts, call the Customer Service Line at 1-800-800-7310, or visit www.yardman.com.

NOTE: Tractor features vary by model. NOT all parts listed above and pictured on the previous page are standard equipment.

Model Series 605 (46" Deck - Manual PTO)

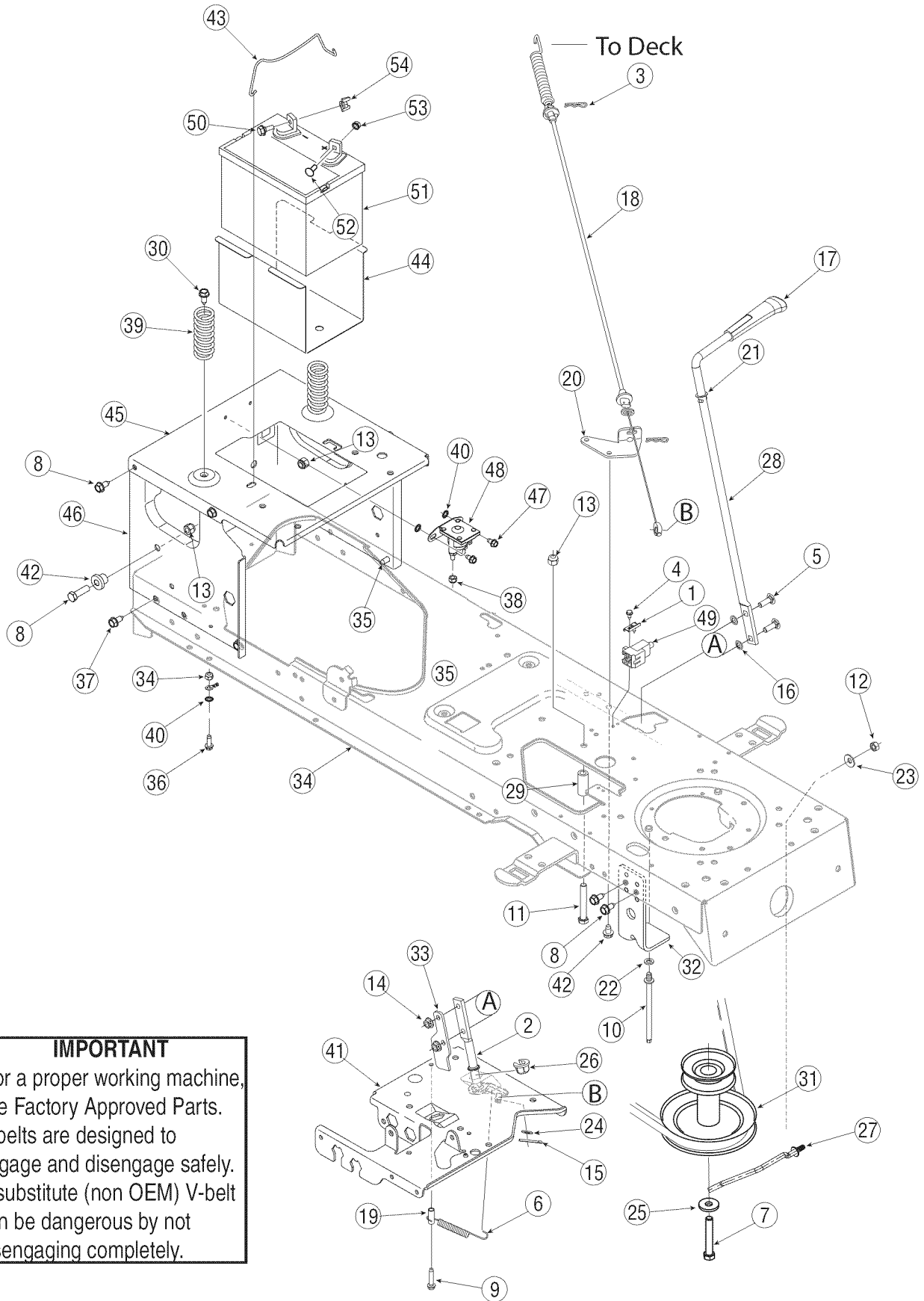

IMPORTANT
 For a proper working machine,
 use Factory Approved Parts.
 V-belts are designed to
 engage and disengage safely.
 A substitute (non OEM) V-belt
 can be dangerous by not
 disengaging completely.

Ref. No.	Part No.	Description
1	17962	Plate, Switch
2	647-04036	Lever Assembly, Engagement
3	714-0145	Click Pin
4	710-0224	Screw, #10-16, 0.500
5	710-0276	Screw, Carriage, 5/16-18, 1.00
6	732-04248	Extension Spring, .38 OD x 3.9 Lg
7	710-04377	Screw, 7/16-20, 2.75, Gr5
8	710-0726	Screw, 5/16-12, 0.750
9	710-0778	Screw, 1/4-20 x 1.50
10	711-1044A	Pin, Belt Guard, 5/16 x 4.75
11	710-0859	Screw, 3/8-16 x 2.50
12	712-04063	Nut, Flange Lock, 5/16-18, GrF
13	712-04065	Nut, Flange Lock, 3/8-16, GrF
14	712-3004A	Nut, Flange Lock, 5/16-18, Gr5
15	714-0470	Pin, Cotter, 1/8 x 1.25
16	726-0201	Nut, Speed, .3125 ID
17	731-2111A	Knob, PTO
18	746-04092	Deck Engagement Cable
19	750-0566A	Spacer, .260 x .372 x 1.030 Lg.
20	783-04590A	Cable Bracket
21	736-0108	Washer, Flat, .510 x .750 x .033
22	736-0119	Washer, Lock, 5/16
23	736-0242	Washer, Bell, .340 x .872 x .060
24	736-0275	Washer, Flat, .344 x .688 x .065
25	736-0322	Washer, Flat, .450 x 1.250 x .164
26	741-0708	Bearing, Flange, Hex Split .500 ID
27	747-1286A	Keeper Rod, Belt

Ref. No.	Part No.	Description
28	747-04470	Engagement Handle, Deck
29	748-0415B	Spacer, .385 ID x .635 OD x 1.54
30	710-1260A	Screw, 5/16-18 x .750
31	756-04207	Pulley, Engine, 3.39 x 6.12 Dia.
32	783-04467	Stop Bracket, Deck-Up
33	783-0744A	Stop Bracket, Engagement
34	683-04173	Frame Assembly, Lower
35	710-0607	Screw, 5/16-18, 0.500
36	710-0642	Screw, 1/4-20, 0.750
37	710-3005	Screw, 3/8-16, 1.25, Gr5
38	712-04064	Nut, Flange Lock, 1/4-20, GrF
39	732-04035	Spring, Compr., 1.28 OD x 3.125
40	736-0222	Washer, Lock, 1/4, External
41	783-04612	Support Bracket, Steering
42	738-04058	Spacer, Shoulder, .38 x 1.0 x .70
43	747-04121A	Hold Rod, Battery
44	783-0349	Battery Tray
45	783-04329A	Seat Bracket, Frame
46	783-04809	Frame, Upper
47	710-0599	Screw, 1/4-20, 0.50
48	725-1426A	Solenoid, 12V, 100 Amp
49	725-04039	Switch, Interlock
50	738-1132	Screw, Shoulder, .250 x .150
51	725-1737	Battery, 190 CCA
52	710-0703	Screw, Carriage, 1/4-20, .75, Gr5
53	712-0271	Nut, Sems, 1/4-20
54	712-3087	Nut, Wing, 1/4-20

10

Illustrated Parts List



To order replacement parts, call the Customer Service Line at 1-800-800-7310, or visit www.yardman.com.

NOTE: Tractor features vary by model. NOT all parts listed above and pictured on the previous page are standard equipment.

Model Series 605 (Electric PTO)

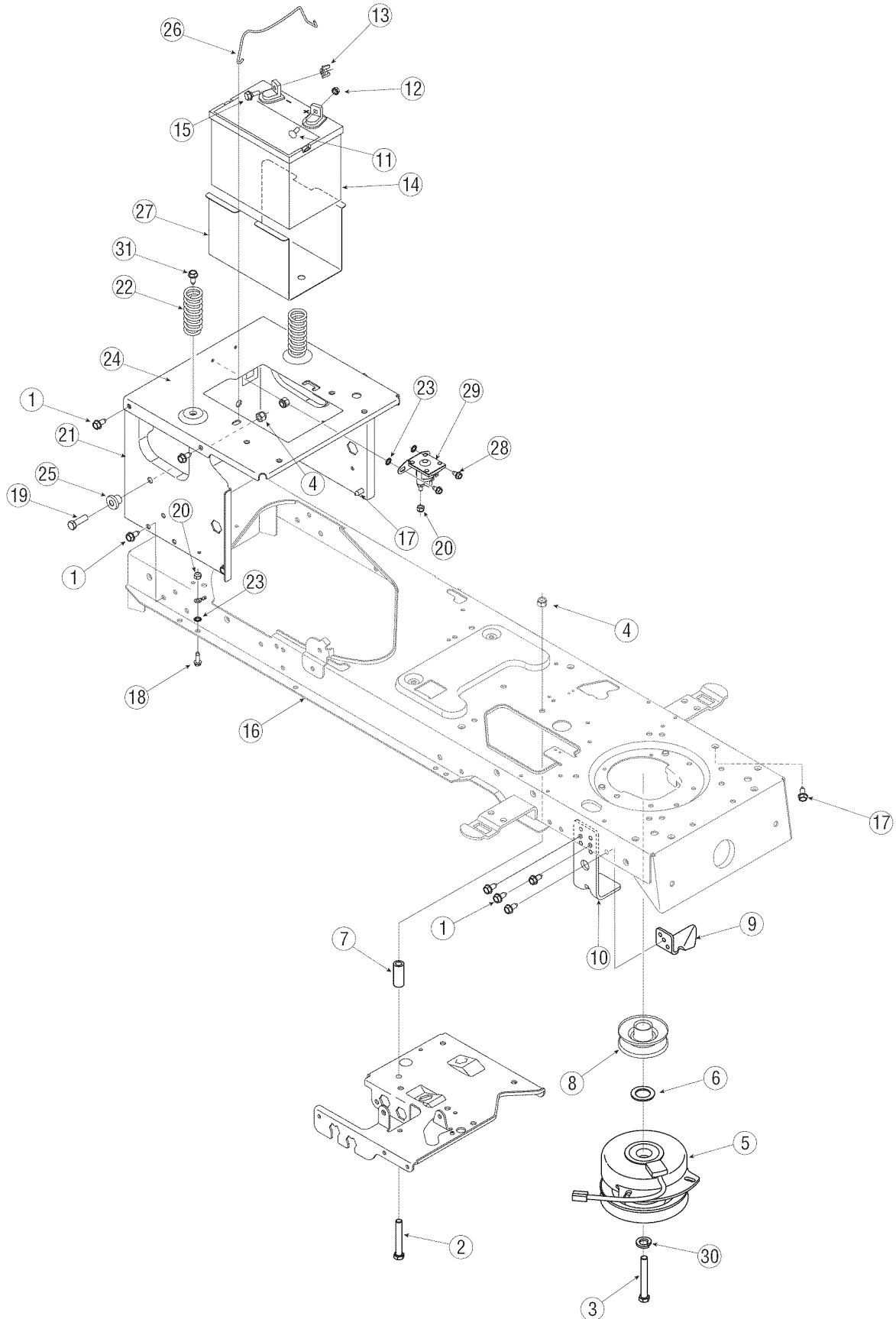

Ref. No.	Part No.	Description
1	710-0726	Screw, 5/16-12, 0.75
2	710-0859	Screw, 3/8-16, 2.50, Gr5
3	710-04379A	Screw, 7/16-20, 3.50, Gr5
4	712-04065	Nut, Flange Lock, 3/8-16, GrF
5	717-04174	PTO Clutch, Electric
6	736-0277	Washer, Flat, 1.031 x 1.620 x.095
7	748-0415B	Spacer,.385 ID x.635 OD x 1.54
8	756-0639	Pulley, Engine, Electric PTO
9	783-04419B	Clutch Bracket
10	783-04467	Deck Bracket, Up-Stop
11	710-0703	Screw, Carriage, 1/4-20,.75, Gr5
12	712-0271	Nut, Sems, 1/4-20
13	712-3087	Nut, Wing, 1/4-20
14	725-1750A	Battery, 235 CCA
15	738-1132	Screw, Shldr,.250 x.150, 1/4-20
16	683-04173	Frame Assembly, Lower
17	710-0607	Screw, 5/16-18, 0.500
18	710-0642	Screw, 1/4-20, 0.750
19	710-3005	Screw, 3/8-16, 1.25, Gr5
20	712-04064	Nut, Flange Lock, 1/4-20, GrF
21	783-04809	Frame, Upper
22	732-04035	Spring, Compr., 1.28 OD x 3.125
23	736-0222	Washer, Lock, 1/4, External
24	783-04329A	Seat Bracket, Frame
25	738-04058	Spacer, Shoulder,.38 x 1.0 x.70
26	747-04121A	Hold Rod, Battery
27	783-0349	Battery Tray
28	710-0599	Screw, 1/4-20 x .500
29	725-1426A	Solenoid, 12V, 100 Amp
30	736-0171	Lock Washer, 7/16
31	710-1260A	Screw, 5/16-18 x .750

10

Illustrated Parts List



To order replacement parts, call the Customer Service Line at 1-800-800-7310, or visit www.yardman.com.

Model Series 605

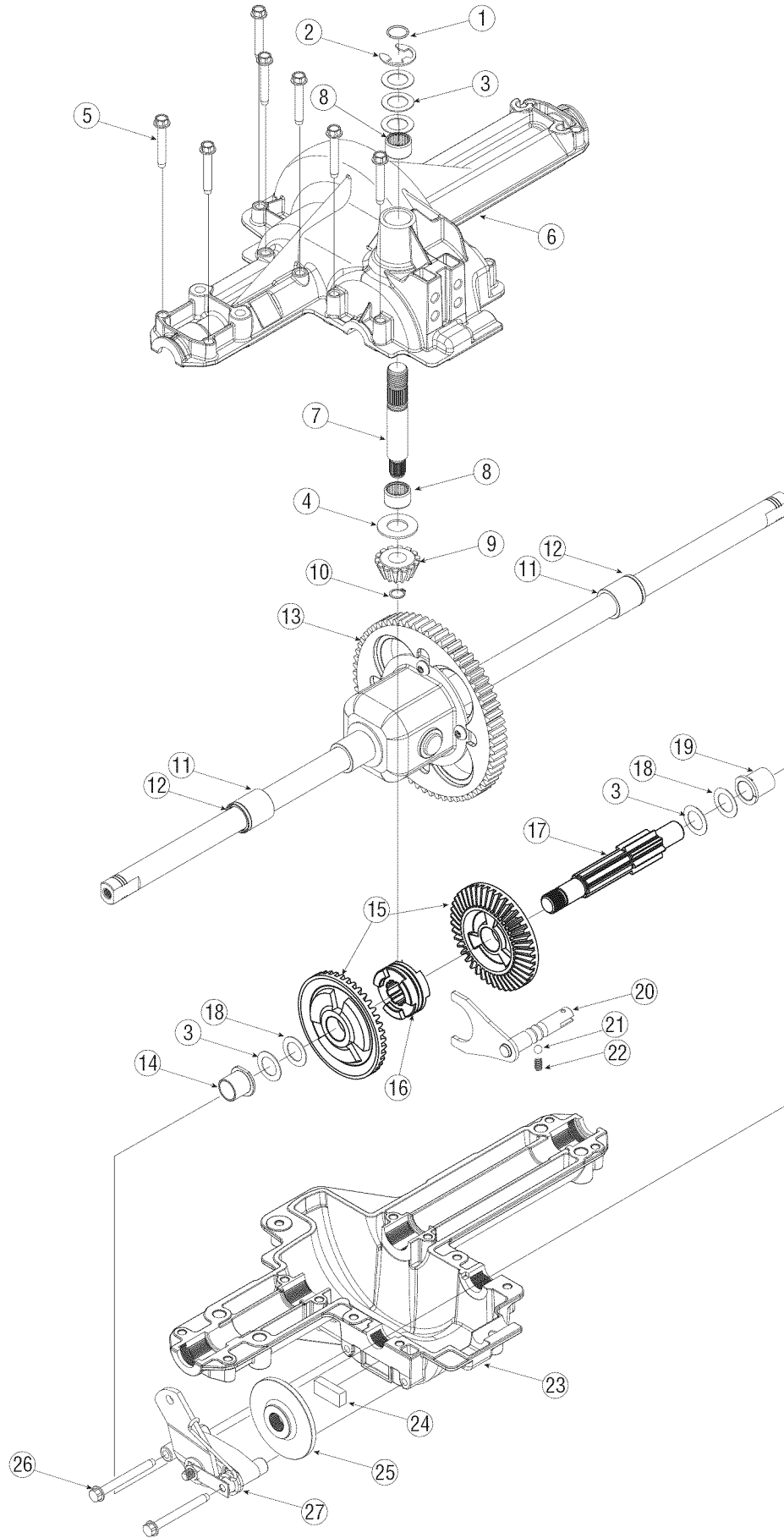

10

Illustrated Parts List



To order replacement parts, call the Customer Service Line at 1-800-800-7310, or visit www.yardman.com.

Ref. No.	Part No.	Description
1	732-0614	Ring, Wire
2	716-0231	Ring, E Type,.750
3	736-0336*	Flat Washer, 5/8 x 1.0 x.030
	736-0337*	Flat Washer, 5/8 x 1.0 x.040
	736-0349*	Flat Washer, 5/8 x 1.0 x.020
4	736-0335	Washer, Thrust.635 x 1.26 x.06
5	710-1325	Self-tapping Screw, 1/4-20 x 1.625
6	719-04017	Upper Housing
7	711-1109	Input Shaft
8	741-0335	Needle Bearing,.625 x.813 x.495
9	717-1464	14-tooth Bevel Pinion
10	716-0108	Retaining Ring,.437
11	741-0340	Sleeve Bearing,.75 x1.0 x 1.0
12	721-0338	Seal,.75 x 1.0 x.125
13	618-04041	Differential Assembly
14	741-0336	Flange Bearing, 5/8 x 3/4 x 3/4
15	717-04056	42-tooth Bevel Gear
16	718-04045	Clutch Collar
17	711-04134	Drive Shaft
18	736-0495*	Thrust Washer, 1.0 x.632 x.0
	736-0494*	Flat Washer,.632 x 1.00 x.035
19	741-0337	Flange Bearing, 5/8 x 3/4 x 15/16
20	611-0011	Detent Shaft Assembly
21	741-0862	Detent Ball
22	732-0863	Compression Spring
23	719-04018	Lower Housing
24	717-0678	Brake Puck
25	761-0202	Brake Disc
26	710-1206	Self-tapping Screw, 1/4-20 x 2.375
27	661-0001	Brake Assembly
—	737-0148	Grease (19 oz.)

* Use applicable flat washer (ref. #'s 3 or 18) in this application allowing .0150/.0020 in. end-play

NOTE: If rebuilding the upper housing, include two ounces (2 oz.) of Unirex® N3 grease (Part No. 737-0289) in the input shaft cavity.

Model Series 605 (42" Deck - Manual PTO)

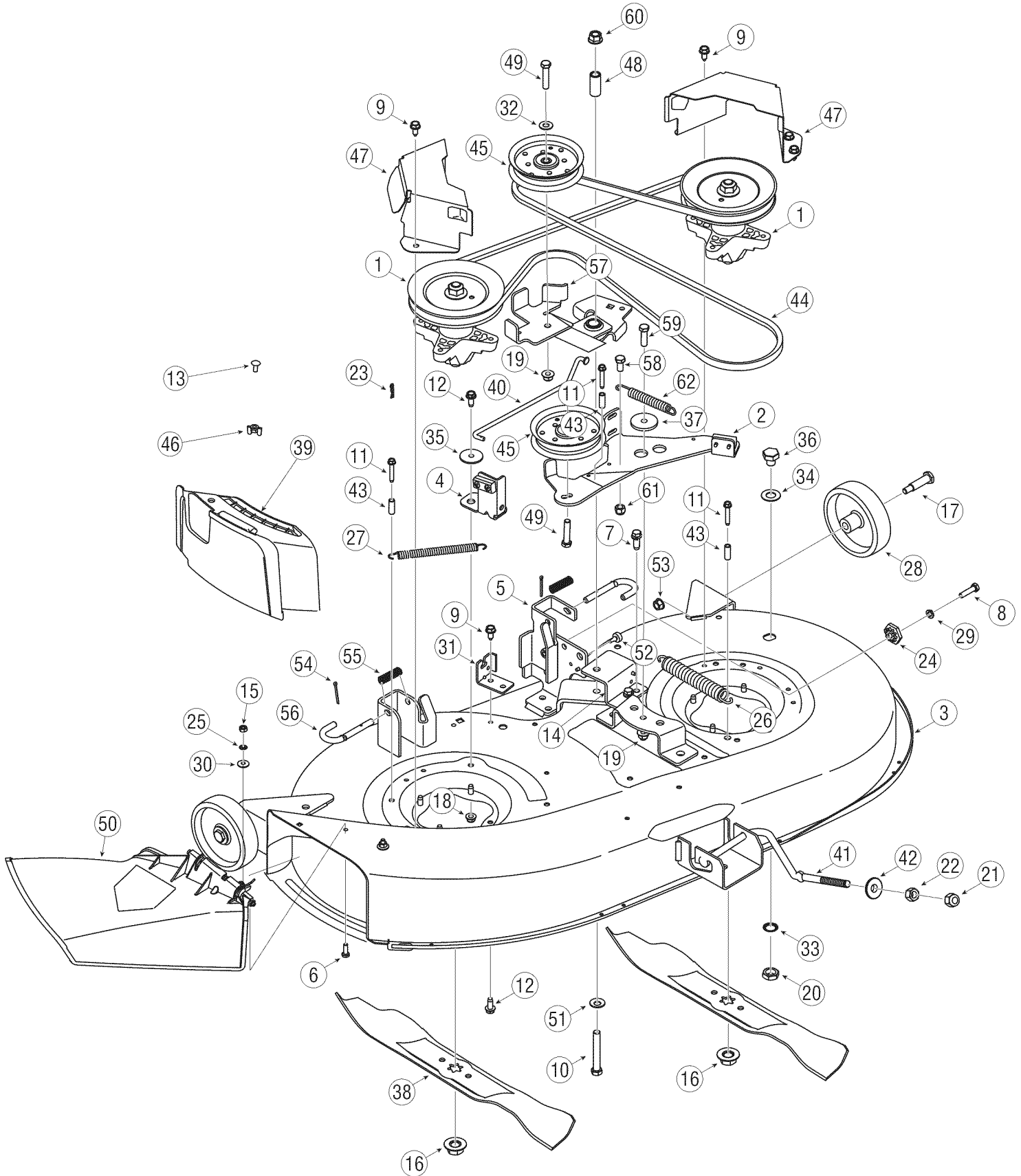

Ref. No.	Part No.	Description
1	618-0624	Spindle Assembly, Pul, 6.23" Dia
2	683-04138A	Brake Assembly, Deck
3	683-04261	Deck Shell, 42"
4	683-04167	Brake Assembly, Deck
5	683-0254B	Brkt. Ass'y, Deck, Hanger LH
6	710-3015	Screw, 1/4-20, .75, Gr5
7	710-0654A	Screw, 3/8-16, 1.00
8	710-0528	Screw, 5/16-18, 1.250
9	710-0726	Screw, 5/16-12, 0.750
10	710-0510	Screw, 7/16-20, 3.00, Gr5
11	710-0778	Screw, 1/4-20, 1.500
12	710-1260A	Screw, 5/16-18, .75
13	710-0134†	Carriage Screw, , 1/4-20 x .62
14	783-05045	Pivot Support Bracket
15	712-3006	Nut, Hex, 1/4-20, Gr5
16	712-0417A	Nut, Flange, 5/8-18
17	738-0373	Screw, Shldr, .498 x 1.53, 3/8-16
18	712-04063	Nut, Flange Lock, 5/16-18, GrF
19	712-04065	Nut, Flange Lock, 3/8-16, GrF
20	712-0641	Nut, Hex, M16-1.5
21	712-3083	Nut, Hex Lock, 1/2-13, Gr8
22	712-0206	Nut, Hex, 1/2-13, Gr5
23	714-0104	Pin, Cot, .072 Dia. x 1.13 Lg
24	717-04074	Gear, Deck Adjustment
25	726-0233	Nut, Push, .25 ID x .50 OD
26	732-0459B	Spring, Exten. , .94 Dia. x 6.74
27	732-04287	Spring, Exten. , .50 Dia. x 6.375
28	734-0973	Wheel, Deck 5.0 x 1.38
29	736-0119	Washer, Lock, 5/16
30	736-0270	Washer, Bell, .265 x .75 x .062
31	783-04740	Deck Engagement Cable Bracket

Ref. No.	Part No.	Description
32	736-0300	Washer, Flat, .406 x .875 x .059
33	736-0760	Washer, Lock
34	736-0187	Washer, Flat, .64 x 1.24 x .06
35	738-04166	Spacer, Shoulder, .5000 x .1475
36	738-04146	Plug, Screw, M16 x 1.5
37	738-04162A	Spacer, Shoulder, .8840 x .190
38	742-0616A	Blade, 21.23", Star 3-in-1
39	731-2363†	Mulch Plug
40	747-04501	Control Rod, Brake
41	747-04269A	Deck Rod, Front Adjustable
42	748-04069	Pivot Cup, Deck Lift
43	750-0566A	Spacer, .260 x .372 x 1.030
44	754-04045	Belt, V-Type
45	756-04129	Idler Pulley, 4.25" Dia.
46	712-3087†	Wing Nut, 1/4-20
47	783-04327A	Cover, Belt, 6.00 Dia.
48	750-04637	Spacr, .455 ID x .680 OD
49	710-0347	Screw, 3/8-16 x 1.75
50	731-1032B	Chute Assembly, Discharge
51	736-0407	Bell Washer, .45 x 1.00 x .062
52	735-0271	Bumper
53	712-0431	Flange Lock Nut, 3/8-16
54	714-0470	Cotter Pin
55	732-0306A	Comp. Spring, .531OD x 1.75 Lg.
56	747-1116	Deck Release Rod
57	683-04252	Deck Idler Assembly
58	710-0216	Screw, 3/8-16 x .75
59	710-3005	Screw, 3/8-16 x 1.25
60	712-0459	Flange Lock Nut, 7/16-20
61	712-3061	Hex Lock Nut, 3/8-24
62	732-0470A	Extension Spring, .53 OD x 4.75

† If Equipped

IMPORTANT

For a proper working machine, use Factory Approved Parts. **V-belts** are designed to engage and disengage safely. A substitute (non OEM) V-belt can be dangerous by not disengaging completely.

NOTE: Tractor features vary by model. NOT all parts listed above and pictured on the previous page are standard equipment.

10

Illustrated Parts List



To order replacement parts, call the Customer Service Line at 1-800-800-7310, or visit www.yardman.com.

Model Series 605 (46" Deck - Manual PTO)

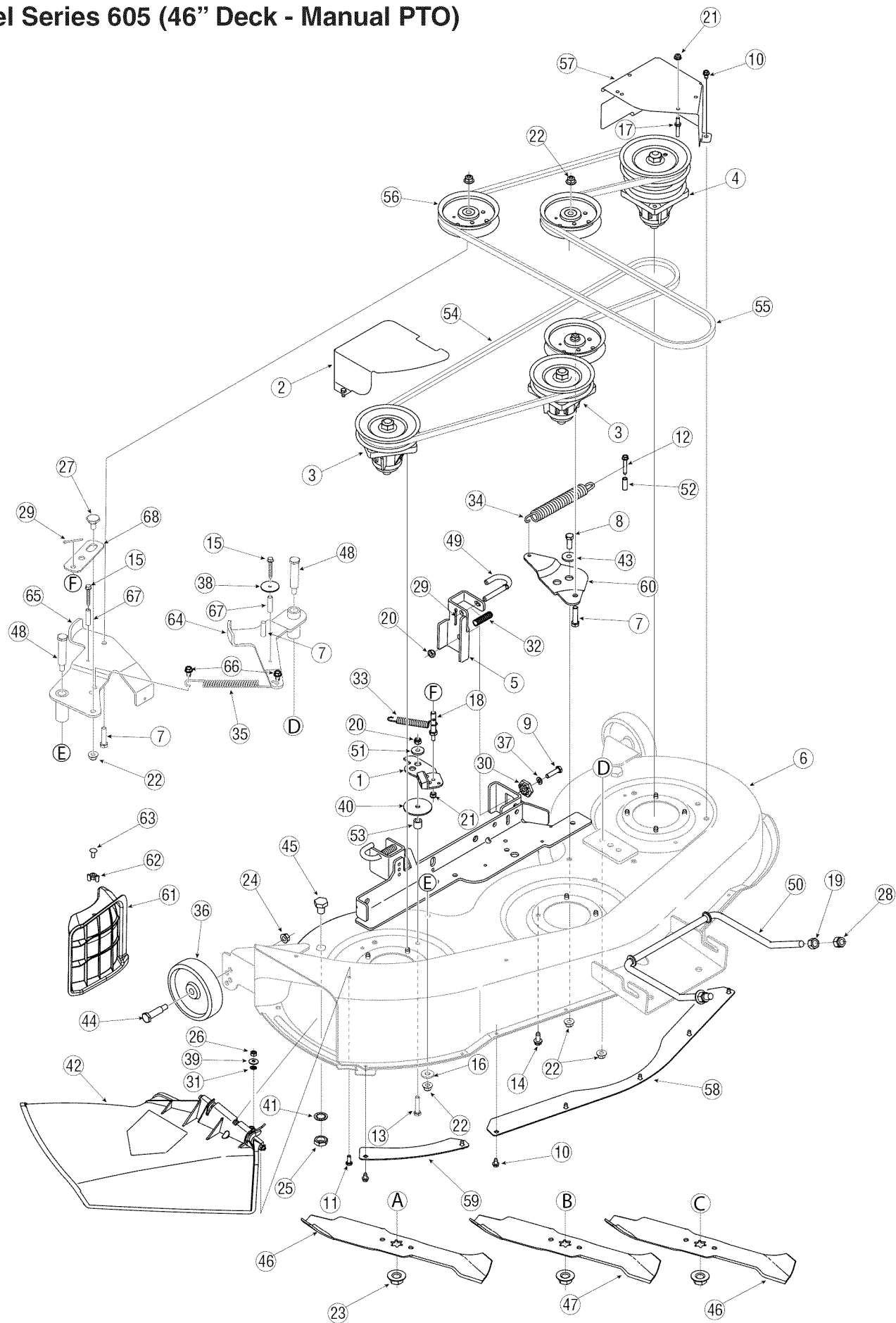

Ref. No.	Part No.	Description
1	17116	Brake Assembly, Deck
2	17258E	RH Belt Cover, Deck 46"
3	618-0240A	Spindle Assembly, 5.00 Dia.
4	618-04134B	Spindle Ass'y, Double Pulley
5	683-0254B	Hanger Bracket Assembly
6	683-04254	Deck Weldment
7	710-0520	Screw, 3/8-16, 1.50, Gr5
8	710-0514	Screw, 3/8-16, 1.00, Gr5
9	710-0528	Screw, 5/16-18, 1.25, Gr5
10	710-0599	Screw, 1/4-20, 0.500
11	710-3015	Screw, 1/4-20, .75, Gr5
12	710-0778	Screw, 1/4-20, 1.500
13	710-0805	Screw, 5/16-18, 1.50, Gr5
14	710-1260A	Screw, Ld, 5/16-18, 0.750
15	710-1026	Screw, 1/4-20 x 1.75
16	736-0247	Washer, Flat, .406 x 1.25 x .157
17	711-0993	Belt Guard Pin 1/4 Dia x 1.43
18	711-1554	Pin, 1/4-20, 3/8 x 2.0
19	712-0206	Nut, Hex, 1/2-13, Gr5
20	712-04063	Nut, Flange Lock, 5/16-18, GrF
21	712-04064	Nut, Flange Lock, 1/4-20, GrF
22	712-04065	Nut, Flange Lock, 3/8-16, GrF
23	712-0417A	Nut, Flange, 5/8-18
24	712-0431	Nut, Flange Lock, 3/8-16, GrF
25	712-0641	Nut, Hex, M16-1.5
26	712-3006	Nut, Hex, 1/4-20, Gr5
27	738-0322	Shld, Screw, .625 Dia. x .217
28	712-3083	Nut, Hex Lock, 1/2-13, Gr8, Nylon
29	714-0470	Pin, Cot, 1/8 x 1.25
30	717-04074	Adjustment Gear, Deck
31	726-0233	Nut, Push, .25 ID x .50 OD
32	732-0306A	Sprg, Compress, .531 OD x 1.75
33	732-0429A	Spring, Extension, .50 Dia x 3.97
34	732-0594A	Spring, Extension, .91 Dia x 7.33

Ref. No.	Part No.	Description
35	732-0944	Spring, Extension, .75 OD x 6.75
36	734-0973	Wheel, Deck 5.0 x 1.38
37	736-0119	Washer, Lock, 5/16
38	736-0211	Washer, Flat, .285 x 1.25 x .06
39	736-0270	Washer, Bell, .265 x .75 x .062
40	736-0418A	Washer, Flat, .34 x 2.25 x .10
41	736-0225	Washer, Lock, 5/8
42	731-1032B	Chute Assembly
43	738-0347	Spacer, Shoulder, .625 ID x 1.69
44	738-0373	Spacer, Shoulder, .498 x 1.53
45	738-04146	Plug
46	742-0611A	Blade, 16.28", Star 3-in-One
47	742-0612A	Blade, 14.88", Star 3-in-One
48	738-04216	Shld. Screw, .625 x 2.515 x .875
49	747-1116	Rod, Deck Release
50	747-1130B	Rod, Deck Adjustment
51	748-0234	Shoulder Spacer
52	750-0566A	Spacer, .260 x .372 x 1.030
53	750-1320	Spacer, .375 x .63 x .595
54	754-0349	Belt, V-Type, Poly, A x 79.10 Lg.
55	754-04122	Belt, V-Type, A x 90.24
56	756-04129	Pulley, Idler, 4.25" Dia.
57	783-1348C	Belt Cover, LH
58	783-0141	Deck Skirt, Center
59	783-0142	Deck Skirt, RH
60	783-04641	Bracket, Idler
61	731-05264†	Mulch Plug
62	712-3087†	Wing Nut
63	710-0134†	Carriage Screw, 1/4-20 x .62
64	683-04250	Idler Bracket Assembly - LH
65	683-04251	Idler Bracket Assembly - RH
66	710-0623	Screw, 3/8-16 x .750
67	750-04456	Spacer, .260 x .372 x 1.420 Lg.
68	783-04991	Brake Bracket

IMPORTANT

For a proper working machine, use Factory Approved Parts. **V-belts** are designed to engage and disengage safely. A substitute (non OEM) V-belt can be dangerous by not disengaging completely.

NOTE: Tractor features vary by model. NOT all parts listed above and pictured on the previous page are standard equipment.

10

Illustrated Parts List



To order replacement parts, call the Customer Service Line at 1-800-800-7310, or visit www.yardman.com.

Model Series 605 (46" Deck - Electric PTO)

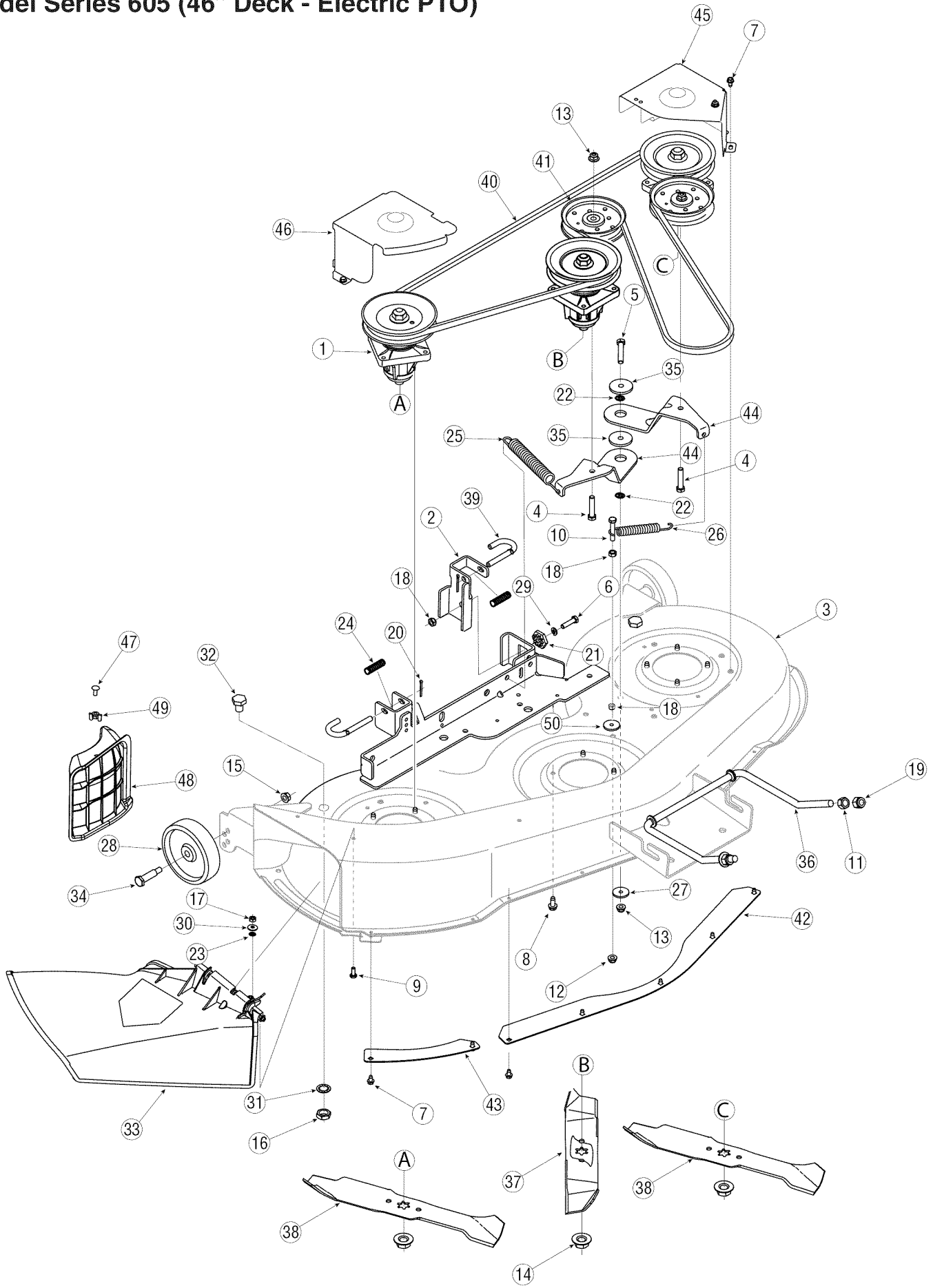

Ref. No.	Part No.	Description
1	618-0625	Spindle Assembly, Pulley 5.75 Dia
2	683-0254B	Deck Hanger Bracket Ass'y, LH
3	683-04104A	Deck Weldment
4	710-0347	Screw, 3/8-16, 1.75, Gr5
5	710-0520	Screw, 3/8-16, 1.50, Gr5
6	710-0528	Screw, 5/16-18, 1.25, Gr5
7	710-0599	Screw, 1/4-20, 0.500
8	710-1260A	Screw, 5/16-18, 0.750
9	710-3015	Screw, 1/4-20, .75, Gr5
10	710-3103	Screw, 5/16-18, 2.00, Gr5
11	712-0206	Nut, Hex, 1/2-13, Gr5
12	712-04063	Nut, Flange Lock, 5/16-18, GrF
13	712-04065	Nut, Flange Lock, 3/8-16, GrF
14	712-0417A	Nut, Flange, 5/8-18
15	712-0431	Nut, Flange Lock, 3/8-16, GrF
16	712-0641	Nut, Hex, M16-1.5
17	712-3006	Nut, Hex, 1/4-20, Gr5
18	712-3010	Nut, Hex, 5/16-18, Gr5
19	712-3083	Nut, Hex Lock, 1/2-13, Gr8, Nylon
20	714-0111	Pin, Cotter, 3/32, 1.0
21	717-04074	Adjustment Gear, Deck
22	726-0269	Nut, Speed, 3/8
23	726-0233	Nut, Push, .25 Id x .50 OD
24	732-0306A	Spring, Compres., .531 OD x 1.75
25	732-0594A	Spring, Extension, .91 Dia. x 7.33

Ref. No.	Part No.	Description
26	732-0826	Spring, Extension, .865 OD x 4.68
27	736-0247	Washer, Flat, .406 x 1.25 x .157
28	734-0973	Wheel, Deck 5.0 x 1.38
29	736-0119	Washer, Lock, 5/16, Regular Duty
30	736-0270	Washer, Bell, .265 x .75 x .062
31	736-0760	Washer, Lock, 17 x 23.8 x 1.95
32	738-04146	Plug, Screw
33	731-1032B	Chute Assembly, Side Discharge
34	738-0373	Screw, Shlder, .498 x 1.53, 3/8-16
35	738-04162A	Spacer, Shoulder, .8840 x .190
36	747-1130B	Rod, Deck, Adjust
37	742-0612A	Blade, 14.88", Star 3-in-1
38	742-0611A	Blade, 16.28", Star 3-in-1
39	747-1116	Hndl Rod, Deck Release .375 Dia
40	754-04118	Belt, V-Type
41	756-04129	Pulley, Idler, 4.25"Dia.
42	783-0141	Deck Skirt, Center
43	783-0142	Deck Skirt, RH
44	783-05118	Bracket, Idler
45	783-0747B	Belt Cover, LH
46	783-0805C	Belt Cover, RH
47	710-0134	Carriage Screw, 1/4-20, .62
48	731-05264	Mulch Plug
49	712-3087	Nut, Wing, 1/4-20
50	736-0343	Washer, Flat, .330 x 1.25 x .120

10

Illustrated Parts List



To order replacement parts, call the Customer Service Line at 1-800-800-7310, or visit www.yardman.com.

IMPORTANT

For a proper working machine, use Factory Approved Parts. **V-belts** are designed to engage and disengage safely. A substitute (non OEM) V-belt can be dangerous by not disengaging completely.

NOTE: Tractor features vary by model. NOT all parts listed above and pictured on the previous page are standard equipment.

NOTES:

Use this page to make notes and write down important information.



**CALIFORNIA EMISSION CONTROL WARRANTY STATEMENT
YOUR WARRANTY RIGHTS AND OBLIGATIONS**

The California Air Resources Board and MTD Consumer Group Inc are pleased to explain the evaporative emission control system warranty on your 2006 lawn mower. In California, new lawn mower must be designed, built and equipped to meet the State's stringent anti-smog standards. MTD Consumer Group Inc must warrant the EECS on your lawn mower for the period of time listed below provided there has been no abuse, neglect or improper maintenance of your lawn mower.

Your EECS may include parts such as the carburetor, fuel-injection system, the ignition system, catalytic converter, fuel tanks, fuel lines, fuel caps, valves, canisters, filters, vapor hoses, clamps, connectors, and other associated emission-related components.

Where a warrantable condition exists, MTD Consumer Group Inc will repair your lawn mower at no cost to you including diagnosis, parts and labor.

MANUFACTURER'S WARRANTY COVERAGE:

This evaporative emission control system is warranted for two years. If any evaporative emission-related part on your equipment is defective, the part will be repaired or replaced by MTD Consumer Group Inc.

OWNER'S WARRANTY RESPONSIBILITIES:

As the lawn mower owner, you are responsible for performance of the required maintenance listed in your owner's manual. MTD Consumer Group Inc recommends that you retain all receipts covering maintenance on your lawn mower, but MTD Consumer Group Inc cannot deny warranty solely for the lack of receipts.

As the lawn mower owner, you should however be aware that MTD Consumer Group Inc may deny you warranty coverage if your lawn mower or a part has failed due to abuse, neglect, or improper maintenance or unapproved modifications.

You are responsible for presenting your lawn mower to MTD Consumer Group Inc's distribution center or service center as soon as the problem exists. The warranty repairs should be completed in a reasonable amount of time, not to exceed 30 days. If you have a question regarding your warranty coverage, you should contact the MTD Consumer Group Inc Service Department at 1-800-800-7310.

GENERAL EMISSIONS WARRANTY COVERAGE:

MTD Consumer Group Inc warrants to the ultimate purchaser and each subsequent purchaser that the lawn mower is: Designed, built and equipped so as to conform with all applicable regulations; and free from defects in materials and workmanship that cause the failure of a warranted part to be identical in all material respects to that part as described in MTD Consumer Group Inc's application for certification.

The warranty period begins on the date the lawn mower is delivered to an ultimate purchaser or first placed into service. The warranty period is two years.

Subject to certain conditions and exclusions as stated below, the warranty on emission-related parts is as follows:

1. Any warranted part that is not scheduled for replacement as required maintenance in the written instructions supplied, is warranted for the warranty period stated above. If the part fails during the period of warranty coverage, the part will be repaired or replaced by MTD Consumer Group Inc according to subsection (4) below. Any such part repaired or replaced under warranty will be warranted for the remainder of the period.
2. Any warranted part that is scheduled only for regular inspection in the written instructions supplied is warranted for the warranty period stated above. Any such part repaired or replaced under warranty will be warranted for the remaining warranty period.
3. Any warranted part that is scheduled for replacement as required maintenance in the written instructions supplied is warranted for the period of time before the first scheduled replacement date for that part. If the part fails before the first scheduled replacement, the part will be repaired or replaced by MTD Consumer Group Inc according to subsection (4) below. Any such part repaired or replaced under warranty will be warranted for the remainder of the period prior to the first scheduled replacement point for the part.
4. Repair or replacement of any warranted part under the warranty provisions herein must be performed at a warranty station at no charge to the owner.
5. Notwithstanding the provisions herein, warranty services or repairs will be provided at all of our distribution centers that are franchised to service the subject engines or equipment.
6. The lawn mower owner will not be charged for diagnostic labor that is directly associated with diagnosis of a defective, emission-related warranted part, provided that such diagnostic work is performed at a warranty station.
7. MTD Consumer Group Inc is liable for damages to other engine or equipment components proximately caused by a failure under warranty of any warranted part.
8. Throughout the lawn mower warranty period stated above, MTD Consumer Group Inc will maintain a supply of warranted parts sufficient to meet the expected demand for such parts.
9. Any replacement part may be used in the performance of any warranty maintenance or repairs and must be provided without charge to the owner. Such use will not reduce the warranty obligations of MTD Consumer Group Inc.
10. Add-on or modified parts that are not exempted by the Air Resources Board may not be used. The use of any non-exempted add-on or modified parts by the ultimate purchaser will be grounds for disallowing a warranty claims. MTD Consumer Group Inc will not be liable to warrant failures of warranted parts caused by the use of a non-exempted add-on or modified part.

WARRANTED PARTS:

The repair or replacement of any warranted part otherwise eligible for warranty coverage may be excluded from such warranty coverage if MTD Consumer Group Inc demonstrates that the lawn mower has been abused, neglected, or improperly maintained, and that such abuse, neglect, or improper maintenance was the direct cause of the need for repair or replacement of the part. That notwithstanding, any adjustment of a component that has a factory installed, and properly operating, adjustment limiting device is still eligible for warranty coverage. The following emission warranty parts list are covered: Fuel Line, Fuel Line Clamps

MANUFACTURER'S LIMITED WARRANTY FOR



The limited warranty set forth below is given by MTD LLC with respect to new merchandise purchased and used in the United States, its possessions and territories.

"MTD" warrants this product against defects in material and workmanship for a period of two (2) years commencing on the date of original purchase and will, at its option, repair or replace, free of charge, any part found to be defective in materials or workmanship. This limited warranty shall only apply if this product has been operated and maintained in accordance with the Operator's Manual furnished with the product, and has not been subject to misuse, abuse, commercial use, neglect, accident, improper maintenance, alteration, vandalism, theft, fire, water, or damage because of other peril or natural disaster. Damage resulting from the installation or use of any part, accessory or attachment not approved by MTD for use with the product(s) covered by this manual will void your warranty as to any resulting damage.

Normal wear parts are warranted to be free from defects in material and workmanship for a period of thirty (30) days from the date of purchase. Normal wear parts include, but are not limited to items such as: batteries, belts, blades, blade adapters, grass bags, rider deck wheels, seats, snow thrower skid shoes, shave plates, auger spiral rubber and tires.

HOW TO OBTAIN SERVICE: Warranty service is available, WITH PROOF OF PURCHASE, through your local authorized service dealer. To locate the dealer in your area, check your Yellow Pages, or contact MTD LLC at P.O. Box 361131, Cleveland, Ohio 44136-0019, or call 1-800-800-7310 or log on to our Web site at www.mtdproducts.com.

This limited warranty does **not** provide coverage in the following cases:

- a. The engine or component parts thereof. These items may carry a separate manufacturer's warranty. Refer to applicable manufacturer's warranty for terms and conditions.
- b. Log splitter pumps, valves, and cylinders have a separate one year warranty.
- c. Routine maintenance items such as lubricants, filters, blade sharpening, tune-ups, brake adjustments, clutch adjustments, deck adjustments, and normal deterioration of the exterior finish due to use or exposure.
- d. Service completed by someone other than an authorized service dealer.

- e. MTD does not extend any warranty for products sold or exported outside of the United States, its possessions and territories, except those sold through MTD's authorized channels of export distribution.
- f. Replacement parts that are not genuine MTD parts.
- g. Transportation charges and service calls.

No implied warranty, including any implied warranty of merchantability of fitness for a particular purpose, applies after the applicable period of express written warranty above as to the parts as identified. No other express warranty, whether written or oral, except as mentioned above, given by any person or entity, including a dealer or retailer, with respect to any product, shall bind MTD. During the period of the warranty, the exclusive remedy is repair or replacement of the product as set forth above.

The provisions as set forth in this warranty provide the sole and exclusive remedy arising from the sale. MTD shall not be liable for incidental or consequential loss or damage including, without limitation, expenses incurred for substitute or replacement lawn care services or for rental expenses to temporarily replace a warranted product.

Some states do not allow the exclusion or limitation of incidental or consequential damages, or limitations on how long an implied warranty lasts, so the above exclusions or limitations may not apply to you.

In no event shall recovery of any kind be greater than the amount of the purchase price of the product sold. **Alteration of safety features of the product shall void this warranty.** You assume the risk and liability for loss, damage, or injury to you and your property and/or to others and their property arising out of the misuse or inability to use the product.

This limited warranty shall not extend to anyone other than the original purchaser or to the person for whom it was purchased as a gift.

HOW STATE LAW RELATES TO THIS WARRANTY: This limited warranty gives you specific legal rights, and you may also have other rights which vary from state to state.

IMPORTANT: Owner must present Original Proof of Purchase to obtain warranty coverage.