

# OPERATOR'S MANUAL



## Single-Stage Snow Thrower — Models 2N1 & 2P5

### **⚠ WARNING**

**READ AND FOLLOW ALL SAFETY RULES AND INSTRUCTIONS IN THIS MANUAL  
BEFORE ATTEMPTING TO OPERATE THIS MACHINE.  
FAILURE TO COMPLY WITH THESE INSTRUCTIONS MAY RESULT IN PERSONAL INJURY.**

---

MTD LLC, P.O. BOX 361131 CLEVELAND, OHIO 44136-0019

---

## Thank You

Thank you for purchasing a Snow Thrower manufactured by MTD LLC. It was carefully engineered to provide excellent performance when properly operated and maintained.

Please read this entire manual prior to operating the equipment. It instructs you how to safely and easily set up, operate and maintain your machine. Please be sure that you, and any other persons who will operate the machine, carefully follow the recommended safety practices at all times. Failure to do so could result in personal injury or property damage.

All information in this manual is relative to the most recent product information available at the time of printing. Review this manual frequently to familiarize yourself with the unit, its features and operation. Please be aware that this Operator's Manual may cover a range of product specifications for various models. Characteristics and features discussed and/or illustrated in this manual may not be applicable to all models. MTD LLC reserves the right to change product specifications, designs and equipment without notice and without incurring obligation.

This product has met the rigid safety standards of the Outdoor Power Equipment Institute and an independent testing laboratory. If you have any problems or questions concerning the unit, phone your local authorized MTD service dealer or contact us directly. MTD's Customer Support telephone numbers, website address and mailing address can be found on this page. We want to ensure your complete satisfaction at all times.

Throughout this manual, all references to *right* and *left* side of the machine are observed from the operating position

The engine manufacturer is responsible for all engine-related issues with regards to performance, power-rating, specifications, warranty and service. Please refer to the engine manufacturer's Owner's/Operator's Manual, packed separately with your unit, for more information.

## Table of Contents

<b>Safe Operation Practices .....</b>	<b>3</b>	<b>Engine Maintenance .....</b>	<b>16</b>
<b>Assembly &amp; Set-Up .....</b>	<b>7</b>	<b>Service .....</b>	<b>19</b>
<b>Controls &amp; Features.....</b>	<b>10</b>	<b>Troubleshooting .....</b>	<b>20</b>
<b>Operation.....</b>	<b>12</b>	<b>Replacement Parts .....</b>	<b>21</b>
<b>Maintenance &amp; Adjustment.....</b>	<b>14</b>	<b>Warranties .....</b>	<b>22</b>

## Record Product Information

Before setting up and operating your new equipment, please locate the model plate on the equipment and record the information in the provided area to the right. You can locate the model plate by standing at the operator's position and looking down at the rear of the deck. This information will be necessary, should you seek technical support via our web site, Customer Support Department, or with a local authorized service dealer.

### MODEL NUMBER

--	--	--	--	--	--	--	--	--	--	--	--

### SERIAL NUMBER

--	--	--	--	--	--	--	--	--	--	--	--

## Customer Support

**Please do NOT return the unit to the retailer or dealer without first contacting our Customer Support Department.**

If you have difficulty assembling this product or have any questions regarding the controls, operation, or maintenance of this unit, you can seek help from the experts. Choose from the options below:

- ◇ Visit us on the web at [www.mtdproducts.com](http://www.mtdproducts.com)
- ◇ Call a Customer Support Representative at (800) 800-7310 or (330) 220-4683
- ◇ Write us at MTD LLC • P.O. Box 361131 • Cleveland, OH • 44136-0019



**WARNING!** This symbol points out important safety instructions which, if not followed, could endanger the personal safety and/or property of yourself and others. Read and follow all instructions in this manual before attempting to operate this machine. Failure to comply with these instructions may result in personal injury.

When you see this symbol. **HEED ITS WARNING!**

## CALIFORNIA PROPOSITION 65



**WARNING!** Engine Exhaust, some of its constituents, and certain vehicle components contain or emit chemicals known to State of California to cause cancer and birth defects or other reproductive harm.



**DANGER:** This machine was built to be operated according to the safe operation practices in this manual. As with any type of power equipment, carelessness or error on the part of the operator can result in serious injury. This machine is capable of amputating fingers, hands, toes and feet and throwing foreign objects. Failure to observe the following safety instructions could result in serious injury or death.

### Training

1. Read, understand, and follow all instructions on the machine and in the manual(s) before attempting to assemble and operate. Keep this manual in a safe place for future and regular reference and for ordering replacement parts.
2. Be familiar with all controls and their proper operation. Know how to stop the machine and disengage them quickly.
3. Never allow children under 14 years of age to operate this machine. Children 14 and over should read and understand the instructions and safe operation practices in this manual and on the machine and be trained and supervised by an adult.
4. Never allow adults to operate this machine without proper instruction.
5. Thrown objects can cause serious personal injury. Plan your snow-throwing pattern to avoid discharge of material toward roads, bystanders and the like.
6. Keep bystanders, pets and children at least 75 feet from the machine while it is in operation. Stop machine if anyone enters the area.
7. Exercise caution to avoid slipping or falling, especially when operating in reverse.

### Preparation

Thoroughly inspect the area where the equipment is to be used. Remove all doormats, newspapers, sleds, boards, wires and other foreign objects, which could be tripped over or thrown by the auger/impeller.

1. Always wear safety glasses or eye shields during operation and while performing an adjustment or repair to protect your eyes. Thrown objects which ricochet can cause serious injury to the eyes.
2. Do not operate without wearing adequate winter outer garments. Do not wear jewelry, long scarves or other loose clothing, which could become entangled in moving parts. Wear footwear which will improve footing on slippery surfaces.
3. Use a grounded three-wire extension cord and receptacle for all machines with electric start engines.
4. Disengage all control levers before starting the engine.
5. Never attempt to make any adjustments while engine is running, except where specifically recommended in the operator's manual.
6. Let engine and machine adjust to outdoor temperature before starting to clear snow.

## Safe Handling of Gasoline

To avoid personal injury or property damage use extreme care in handling gasoline. Gasoline is extremely flammable and the vapors are explosive. Serious personal injury can occur when gasoline is spilled on yourself or your clothes which can ignite. Wash your skin and change clothes immediately.

- a. Use only an approved gasoline container.
  - b. Extinguish all cigarettes, cigars, pipes and other sources of ignition.
  - c. Never fuel machine indoors.
  - d. Never remove gas cap or add fuel while the engine is hot or running.
  - e. Allow engine to cool at least two minutes before refueling.
  - f. Never over fill fuel tank. Fill tank to no more than ½ inch below bottom of filler neck to provide space for fuel expansion.
  - g. Replace gasoline cap and tighten securely.
  - h. If gasoline is spilled, wipe it off the engine and equipment. Move machine to another area. Wait 5 minutes before starting the engine.
  - i. Never store the machine or fuel container inside where there is an open flame, spark or pilot light (e.g. furnace, water heater, space heater, clothes dryer etc.).
  - j. Allow machine to cool at least 5 minutes before storing.
  - k. Never fill containers inside a vehicle or on a truck or trailer bed with a plastic liner. Always place containers on the ground away from your vehicle before filling.
  - l. If possible, remove gas-powered equipment from the truck or trailer and refuel it on the ground. If this is not possible, then refuel such equipment on a trailer with a portable container, rather than from a gasoline dispenser nozzle.
  - m. Keep the nozzle in contact with the rim of the fuel tank or container opening at all times until fueling is complete. Do not use a nozzle lock-open device.
5. Never run an engine indoors or in a poorly ventilated area. Engine exhaust contains carbon monoxide, an odorless and deadly gas.
  6. Do not operate machine while under the influence of alcohol or drugs.
  7. Muffler and engine become hot and can cause a burn. Do not touch. Keep children away.
  8. Exercise extreme caution when operating on or crossing gravel surfaces. Stay alert for hidden hazards or traffic.
  9. Exercise caution when changing direction and while operating on slopes.
  10. Plan your snow-throwing pattern to avoid discharge towards windows, walls, cars etc. Thus, avoiding possible property damage or personal injury caused by a ricochet.
  11. Never direct discharge at children, bystanders and pets or allow anyone in front of the machine.
  12. Do not overload machine capacity by attempting to clear snow at too fast of a rate.
  13. Never operate this machine without good visibility or light. Always be sure of your footing and keep a firm hold on the handles. Walk, never run.
  14. Disengage power to the auger/impeller when transporting or not in use.
  15. Never operate machine at high transport speeds on slippery surfaces. Look down and behind and use care when backing up.
  16. If the machine should start to vibrate abnormally, stop the engine, disconnect the spark plug wire and ground it against the engine. Inspect thoroughly for damage. Repair any damage before starting and operating.
  17. Disengage all control levers and stop engine before you leave the operating position (behind the handles). Wait until the auger/impeller comes to a complete stop before unlogging the chute assembly, making any adjustments, or inspections.
  18. Never put your hand in the discharge or collector openings. Do not unlog chute assembly while engine is running. Shut off engine and remain behind handles until all moving parts have stopped before unlogging.
  19. Use only attachments and accessories approved by the manufacturer (e.g. wheel weights, tire chains, cabs etc.).
  20. When starting engine, pull cord slowly until resistance is felt, then pull rapidly. Rapid retraction of starter cord (kickback) will pull hand and arm toward engine faster than you can let go. Broken bones, fractures, bruises or sprains could result.
  21. If situations occur which are not covered in this manual, use care and good judgment. Contact Customer Support for assistance and the name of your nearest servicing dealer.

## Operation

1. Do not put hands or feet near rotating parts, in the auger/impeller housing or chute assembly. Contact with the rotating parts can amputate hands and feet.
2. The auger/impeller control lever is a safety device. Never bypass its operation. Doing so makes the machine unsafe and may cause personal injury.
3. The control levers must operate easily in both directions and automatically return to the disengaged position when released.
4. Never operate with a missing or damaged chute assembly. Keep all safety devices in place and working.

## Clearing a Clogged Discharge Chute

Hand contact with the rotating impeller inside the discharge chute is the most common cause of injury associated with snow throwers. Never use your hand to clean out the discharge chute.

To clear the chute:

1. SHUT THE ENGINE OFF!
2. Wait 10 seconds to be sure the impeller blades have stopped rotating.
3. Always use a clean-out tool, not your hands.

## Maintenance & Storage

1. Never tamper with safety devices. Check their proper operation regularly. Refer to the maintenance and adjustment sections of this manual.
2. Before cleaning, repairing, or inspecting machine disengage all control levers and stop the engine. Wait until the auger/impeller come to a complete stop. Disconnect the spark plug wire and ground against the engine to prevent unintended starting.
3. Check bolts and screws for proper tightness at frequent intervals to keep the machine in safe working condition. Also, visually inspect machine for any damage.
4. Do not change the engine governor setting or over-speed the engine. The governor controls the maximum safe operating speed of the engine.
5. Snow thrower shave plates and skid shoes are subject to wear and damage. For your safety protection, frequently check all components and replace with original equipment manufacturer's (OEM) parts only. "Use of parts which do not meet the original equipment specifications may lead to improper performance and compromise safety!"
6. Check control levers periodically to verify they engage and disengage properly and adjust, if necessary. Refer to the adjustment section in this operator's manual for instructions.
7. Maintain or replace safety and instruction labels, as necessary.
8. Observe proper disposal laws and regulations for gas, oil, etc. to protect the environment.
9. Prior to storing, run machine a few minutes to clear snow from machine and prevent freeze up of auger/impeller.
10. Never store the machine or fuel container inside where there is an open flame, spark or pilot light such as a water heater, furnace, clothes dryer etc.
11. Always refer to the operator's manual for proper instructions on off-season storage.
12. Check fuel line, tank, cap, and fittings frequently for cracks or leaks. Replace if necessary.
13. Do not crank engine with spark plug removed.

14. According to the Consumer Products Safety Commission (CPSC) and the U.S. Environmental Protection Agency (EPA), this product has an *Average Useful Life* of seven (7) years, or 60 hours of operation. At the end of the *Average Useful Life* have the machine inspected annually by an authorized service dealer to ensure that all mechanical and safety systems are working properly and not worn excessively. Failure to do so can result in accidents, injuries or death.

## Do not modify engine

To avoid serious injury or death, do not modify engine in any way. Tampering with the governor setting can lead to a runaway engine and cause it to operate at unsafe speeds. Never tamper with factory setting of engine governor.

## Notice Regarding Emissions

Engines which are certified to comply with California and federal EPA emission regulations for SORE (Small Off Road Equipment) are certified to operate on regular unleaded gasoline, and may include the following emission control systems: Engine Modification (EM), Oxidizing Catalyst (OC), Secondary Air Injection (SAI) and Three Way Catalyst (TWC) if so equipped.

## Spark Arrestor









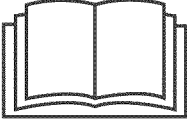

**WARNING!** This machine is equipped with an internal combustion engine and should not be used on or near any unimproved forest-covered, brush covered or grass-covered land unless the engine's exhaust system is equipped with a spark arrester meeting applicable local or state laws (if any).

If a spark arrester is used, it should be maintained in effective working order by the operator. In the State of California the above is required by law (Section 4442 of the California Public Resources Code). Other states may have similar laws. Federal laws apply on federal lands.

A spark arrester for the muffler is available through your nearest engine authorized service dealer or contact the service department, P.O. Box 361131 Cleveland, Ohio 44136-0019.

## Safety Symbols

This page depicts and describes safety symbols that may appear on this product. Read, understand, and follow all instructions on the machine before attempting to assemble and operate.

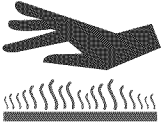
Symbol	Description
	<b>READ THE OPERATOR'S MANUAL(S)</b> Read, understand, and follow all instructions in the manual(s) before attempting to assemble and operate
	<b>WARNING— ROTATING BLADES</b> Keep hands out of inlet and discharge openings while machine is running. There are rotating blades inside
	<b>WARNING— ROTATING BLADES</b> Keep hands out of inlet and discharge openings while machine is running. There are rotating blades inside
	<b>WARNING— ROTATING AUGER</b> Do not put hands or feet near rotating parts, in the auger/impeller housing or chute assembly. Contact with the rotating parts can amputate hands and feet.
	<b>WARNING—THROWN OBJECTS</b> This machine may pick up and throw and objects which can cause serious personal injury.
	<b>WARNING—GASOLINE IS FLAMMABLE</b> Allow the engine to cool at least two minutes before refueling.
	<b>WARNING— CARBON MONOXIDE</b> Never run an engine indoors or in a poorly ventilated area. Engine exhaust contains carbon monoxide, an odorless and deadly gas.
	<b>WARNING— ELECTRICAL SHOCK</b> Do not use the engine's electric starter in the rain
	<b>WARNING— HOT SURFACE</b> Engine parts, especially the muffler, become extremely hot during operation. Allow engine and muffler to cool before touching.



**WARNING!** Your Responsibility—Restrict the use of this power machine to persons who read, understand and follow the warnings and instructions in this manual and on the machine.

**SAVE THESE INSTRUCTIONS!**

## Contents of Carton

- Two Ignition Keys
- One 20 oz. Bottle 5W-30 Oil
- One Snow Thrower Operator's Manual

**NOTE:** This Operator's Manual covers several models. Snow thrower features may vary by model. Not all features in this manual are applicable to all snow thrower models and the snow thrower depicted may differ from yours.

**NOTE:** All references to the left or right side of the snow thrower are from the operator's position. Any exceptions will be noted.

## Assembly

### Positioning the Upper Handle

1. Pivot the upper handle into the operating position making sure not to pinch the cable in the process, as illustrated in Fig. 3-1 until it clicks into place.

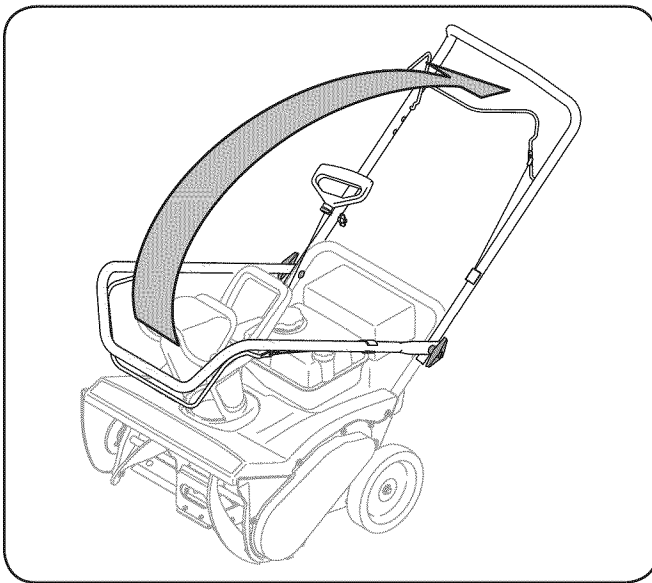

Figure 3-1

2. Tighten the wing knobs to secure the handle in place. See Fig. 3-2.

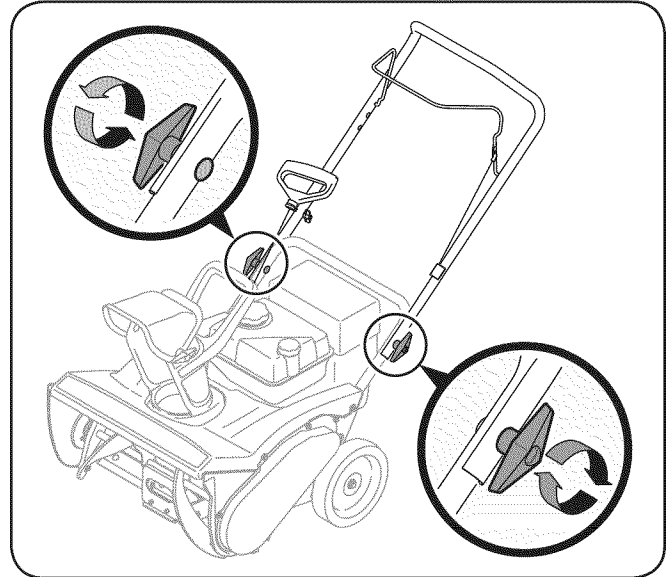

Figure 3-2

### Fuel Recommendations

Use automotive gasoline (unleaded or low leaded to minimize combustion chamber deposits) with a minimum of 87 octane. Gasoline with up to 10% ethanol or 15% MTBE (Methyl Tertiary Butyl Ether) can be used. Never use an oil/gasoline mixture or dirty gasoline. Avoid getting dirt, dust, or water in the fuel tank. **DO NOT use E85 gasoline.**

- Refuel in a well-ventilated area with the engine stopped. Do not smoke or allow flames or sparks in the area where the engine is refueled or where gasoline is stored.
- Do not overfill the fuel tank. After refueling, make sure the tank cap is closed properly and securely.
- Be careful not to spill fuel when refueling. Spilled fuel or fuel vapor may ignite. If any fuel is spilled, make sure the area is dry before starting the engine.
- Avoid repeated or prolonged contact with skin or breathing of vapor.

## Adding Fuel



**WARNING!** Use extreme care when handling gasoline. Gasoline is extremely flammable and the vapors are explosive. Never fuel the machine indoors or while the engine is hot or running. Extinguish cigarettes, cigars, pipes and other sources of ignition.



**WARNING!** Always keep hands and feet clear of equipment moving parts. Do not use a pressurized starting fluid. Vapors are flammable.

1. Clean around fuel fill before removing cap to fuel.
2. A fuel level indicator is located in the fuel tank. Fill tank until fuel reaches the fuel level indicator, Fig. 3-3. Be careful not to overfill.

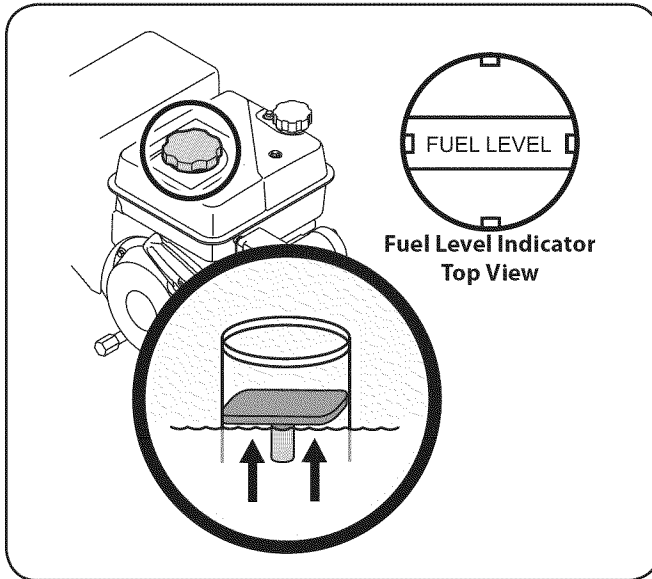

Figure 3-3

## Adding Oil



**CAUTION:** The engine may be shipped with a small amount of oil in the engine. You must be sure to fill the engine with oil between the high and low marks on the dipstick before operating. Running the engine with insufficient oil can cause serious engine damage and void the engine warranty.

1. Place the snow thrower on a flat, level surface.
2. Remove the oil filler cap/dipstick and wipe the dipstick clean. See Fig. 3-4.

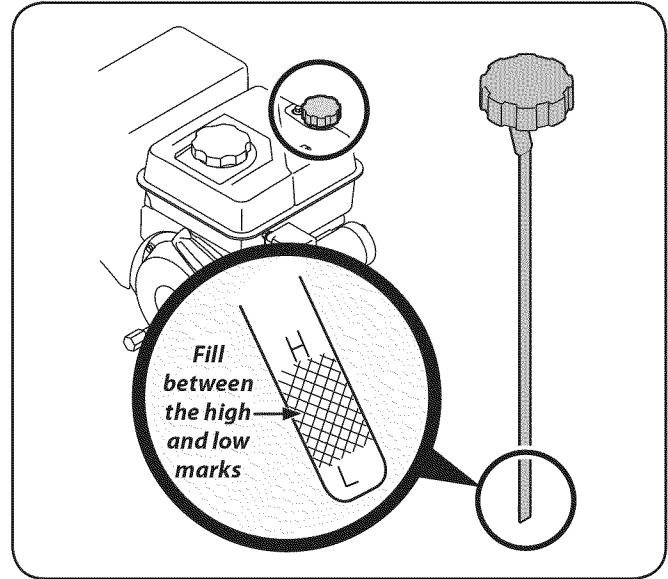

Figure 3-4

**NOTE:** Do not screw in the dipstick when checking the oil level.

3. Slowly add oil until the oil level registers between high (H) and low (L), Fig. 3-4. Refer to the Engine Maintenance section for the correct oil viscosity and engine oil capacity.

**NOTE:** Do not overfill. Overfilling the engine with oil may result in the engine smoking, hard starting or spark plug fouling.



## Adjustments

### Chute Assembly

The pitch of the chute assembly controls the angle at which the snow is thrown.

1. Loosen the wing knob found on the left side of the chute assembly and pivot the upper chute upward or downward to the desired pitch. Retighten the wing knob before operating the snow thrower.
2. Position the chute assembly opening by using the chute handle to throw the snow in the desired direction. See Fig. 3-5.

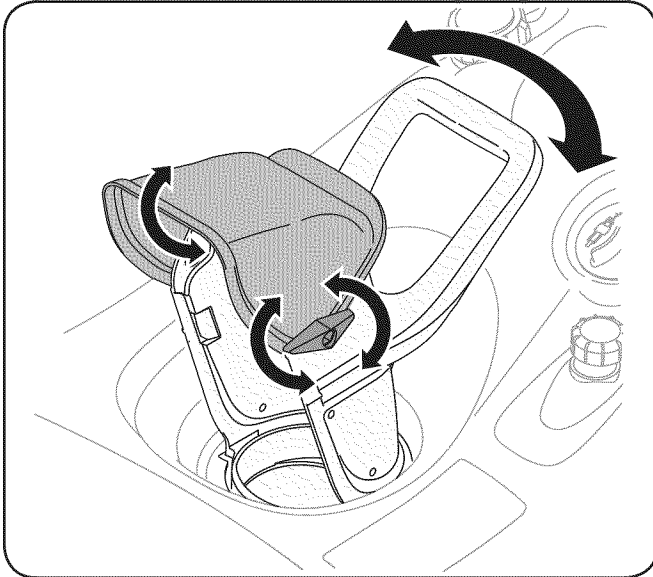

Figure 3-5

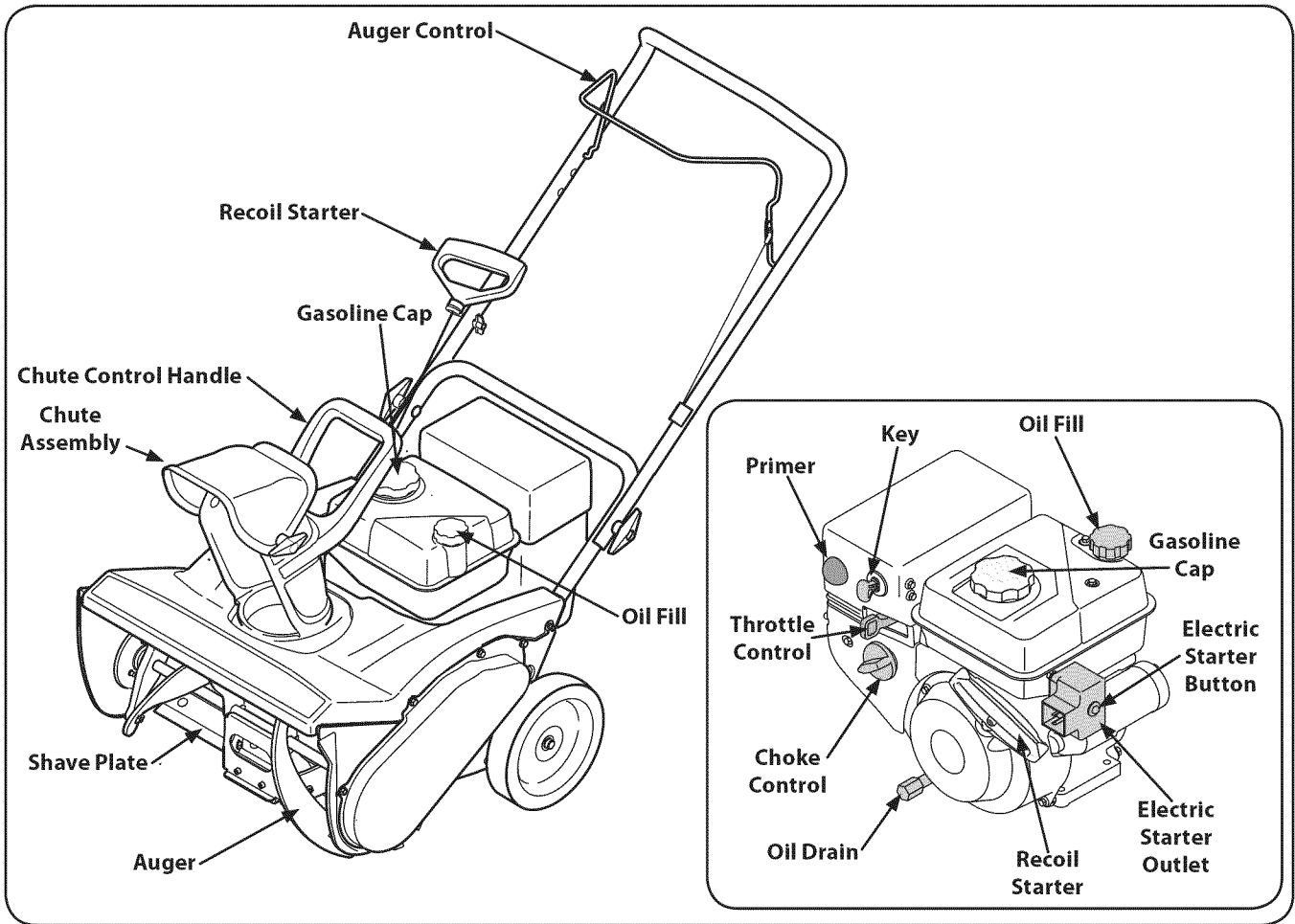
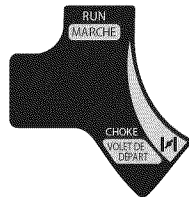

Figure 4-1

**NOTE:** This Operator's Manual covers several models. Snow thrower features may vary by model. Not all features in this manual are applicable to all snow thrower models and the snow thrower depicted may differ from yours.

## Choke Control

Activating the choke control closes the choke plate on carburetor and aids in starting engine. The choke lever slides between the RUN and CHOKE positions.



## Primer

Pressing primer forces fuel directly into engine's carburetor to aid in cold-weather starting.

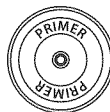

## Recoil Starter

The starter handle is used to manually start the engine.

## Gasoline Cap

Remove the gas cap to add fuel.

## Key

The key is a safety device. It must be fully inserted in order for the engine to start. Remove the key when the snow thrower is not in use.

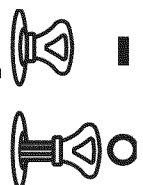

**NOTE:** Do not turn the key in an attempt to start the engine. Doing so may cause it to break.

## Throttle



The throttle control is located on the rear of the engine. It regulates the speed of the engine and will shut off the engine when moved into the STOP position. The throttle control moves between the FAST (rabbit), SLOW (turtle) and STOP positions.

## Auger

When engaged, the auger rotation draws snow into the auger housing and throws it out the discharge chute. Rubber paddles on the auger also aid in propelling the snow thrower as they come in contact with the pavement.

## Auger Control

Located on the upper handle, the auger control is used to engage and disengage drive to the auger. Squeeze the control against the upper handle to engage the auger; release it to disengage.

## Chute Assembly

Rotate the discharge chute to the left or right using the chute handle. The pitch of the discharge chute controls the angle at which the snow is thrown. Loosen the wing knob on the side of the discharge chute before pivoting the discharge chute upward or downward. Retighten the knob once the desired position has been achieved.

## Shave Plate

The shave plate maintains contact with the pavement as the snow thrower is propelled, allowing snow close to the pavement's surface to be discharged.

## Electric Starter Outlet

The electric starter outlet requires the use of a three-prong outdoor extension cord and a 120V power source/wall outlet.

**NOTE:** The electric starter is mounted to the plastic shroud and is shown in Fig. 4-1 attached to the engine for easier reference.

## Electric Starter Button

Pressing the electric starter button engages the engine's electric starter when plugged into a 120V power source.

## Starting the Engine



**WARNING!** Always keep hands and feet clear of moving parts. Do not use a pressurized starting fluid. Vapors are flammable.

**NOTE:** Allow the engine to warm up for a few minutes after starting. The engine will not develop full power until it reaches operating temperatures.

### Electric Starter



**WARNING!** The electric starter is equipped with a grounded three-wire power cord and plug, and is designed to operate on 120 volt AC household current. It must be used with a properly grounded three-prong receptacle at all times to avoid the possibility of electric shock. Follow all instructions carefully prior to operating the electric starter. DO NOT use electric starter in rain.

1. Determine that your home's wiring is a three-wire grounded system. Ask a licensed electrician if you are unsure. If you have a grounded three-prong receptacle, proceed as follows. If you do not have the proper house wiring, DO NOT use the electric starter under any conditions.
2. Insert the key fully into the slot, Fig. 5-1. Make sure it snaps into place. DO NOT turn the key. The engine cannot start unless the key is inserted into the ignition switch.

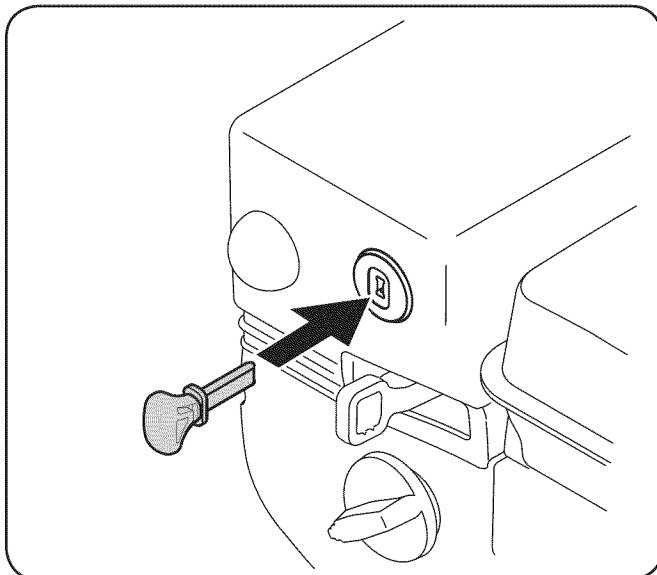

Figure 5-1

3. Plug the extension cord into the electric outlet located on the plastic shroud. Plug the other end of extension cord into a three-prong 120-volt, grounded, AC outlet in a well-ventilated area. See Fig. 5-2.

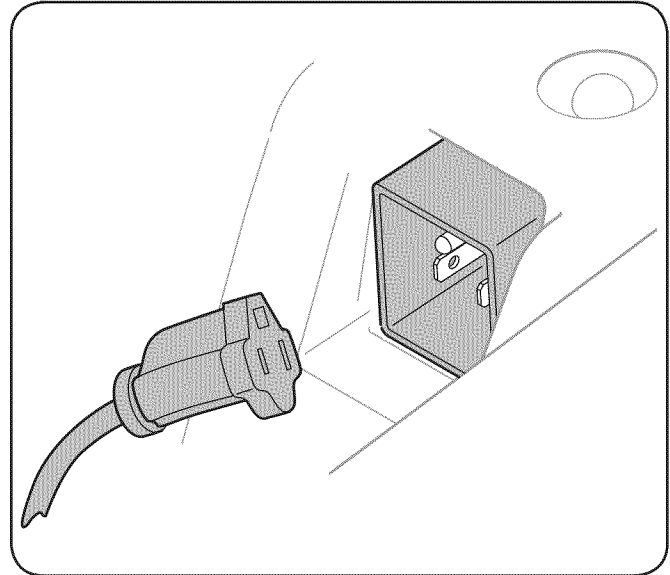





Figure 5-2

4. Move the throttle control to the FAST  (rabbit) position.
5. Move the choke to the CHOKE  position (cold engine start). If the engine is warm, place the choke in the RUN position.
6. Push the primer three (3) times, making sure to cover the vent hole when pushing. If the engine is warm, push the primer only once. Always cover the vent hole when pushing. Cool weather may require priming to be repeated.
7. Push the starter button to start the engine. Once the engine starts, immediately release the starter button. The electric starter is equipped with thermal overload protection; the system will temporarily shut-down to allow starter to cool if electric starter becomes overloaded.
8. As the engine warms, slowly move the choke control to the RUN position. If the engine falters, restart the engine and run with the choke at 1/2-choke (mid-way between RUN and CHOKE  position for a short period of time, and then slowly move the choke into the RUN position.
9. After the engine is running, disconnect the power cord from the electric starter. When disconnecting, always unplug the end at the wall outlet before unplugging the opposite end from the engine.



## Recoil Starter



**CAUTION!** Do not pull the starter handle while the engine is running.



**WARNING:** To avoid unsupervised engine operation, never leave the engine unattended while running. Turn the engine off after use and remove key

1. Insert the key fully into the slot, Fig. 5-1. Make sure it snaps into place. **DO NOT** turn the key. The engine cannot start unless the key is inserted into the ignition switch.
2. Move the throttle control to the **FAST**  (rabbit) position.
3. Move the choke to the **CHOKE**  position (cold engine start). If the engine is warm, place the choke in the **RUN** position.
4. Push the primer three (3) times, making sure to cover the vent hole when pushing. If the engine is warm, push the primer only once. Always cover the vent hole when pushing. Cool weather may require priming to be repeated.
5. Pull gently on the starter handle until it begins to resist, then pull quickly and forcefully to overcome the compression. Do not release the handle and allow it to snap back. Return the rope **SLOWLY** to the original position. If required, repeat this step.
6. As the engine warms, slowly move the choke control to the **RUN** position. If the engine falters, restart the engine and run with the choke at half-choke position for a short period of time, and then slowly move the choke into the **RUN** position.

## Stopping the Engine



**WARNING!** To avoid unsupervised engine operation, never leave the machine unattended with the engine running. Turn the engine off after use and remove key

Run the engine for a few minutes before stopping to help dry off any moisture on the engine.

1. Move the throttle control to the **STOP**  position.
2. Remove the key. Removing the key will reduce the possibility of unauthorized starting of the engine while the equipment is not in use. Keep the key in a safe place. The engine cannot start without the key.
3. Wipe any moisture away from the controls on the engine.

## To Engage Auger

1. To engage the auger and start throwing snow, squeeze the auger control against the handle. Release to stop the auger.

## Engaging the Drive

Lift up slightly on the handle to allow the rubber paddles on the auger to contact the pavement and propel the snow thrower forward. Pushing downward on the handle will raise the auger off the ground and stop the forward motion.

**NOTE:** Excessive upward pressure on the handle will result in premature wear on the rubber auger blades which are not be covered by the warranty.

## Clearing a Clogged Discharge Chute



**WARNING!** Never use your hands to clear a clogged chute assembly. Shut off engine and remain behind handles until all moving parts have stopped before using the clean-out tool to clear the chute assembly.

Hand contact with the rotating impeller inside the discharge chute is the most common cause of injury associated with snow throwers. Never use your hand to clean out the discharge chute.

To clear the chute:

1. **SHUT THE ENGINE OFF!**
2. Wait 10 seconds to be sure the impeller blades have stopped rotating.
3. Always use a clean-out tool, not your hands.

## Adjustments



**WARNING!** Before Servicing, repairing or inspecting the snow thrower, disengage the auger control. Stop the engine and remove the key to prevent unintended starting.

### Shave Plate

To check the adjustment of the shave plate, place the machine on a level surface. The wheels, shave plate and auger should all contact the level surface. Note that if the shave plate is adjusted too high, snow may blow under the housing. If the shave plate wears out excessively, or the snow thrower does not self-propel, the shave plate may be too low and needs to be adjusted.

**NOTE:** On new snow throwers or machines with a new shave plate installed, the auger may be slightly off the ground.

To adjust the shave plate proceed as follows:

1. Drain the gas from the snow thrower.
2. Pull the starter cord until resistance is felt. Then tip the snow thrower back until it rests on the handles.
3. Loosen the four lock nuts and bolts which secure the shave plate to the housing. See Fig. 6-1. Move the shave plate to the desired position and retighten the nuts and bolts securely.

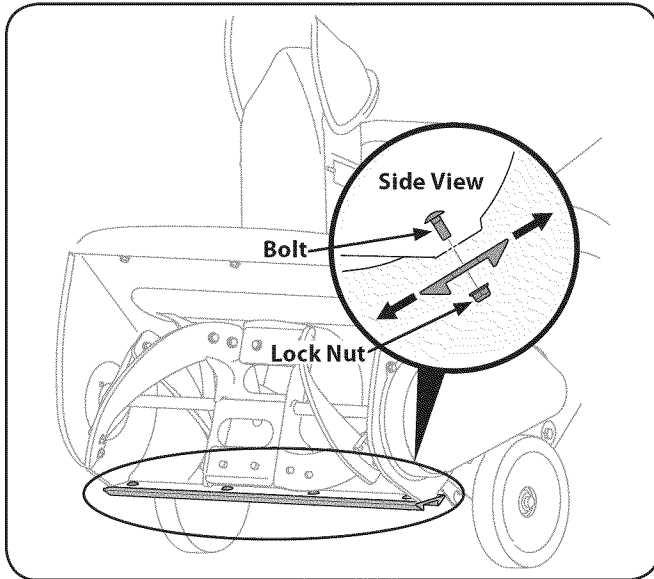

Figure 6-1

4. Tip the snow thrower back to the operating position and pull the starter handle a few times to see if it is difficult to pull.

5. If the starter is difficult to pull, remove the spark plug and pull the handle several times to ensure that any oil trapped in the head is removed.



**CAUTION:** Oil may come out of the spark plug hole when it is removed and the starter handle is pulled.

6. Inspect the spark plug. If it is wet, clean off any oil before re-installing.

### Control Cable

As a result of both the control cable and the auger drive belt stretching due to wear, periodic adjustments may be necessary. If the auger seems to hesitate when rotating, proceed as follows:

The upper hole in the control handle provides for an adjustment in cable tension. To adjust, disconnect the end of control cable from the bottom hole in the control handle and reinsert it in the upper hole. Insert the cable from the outside as shown in Fig. 6-2.

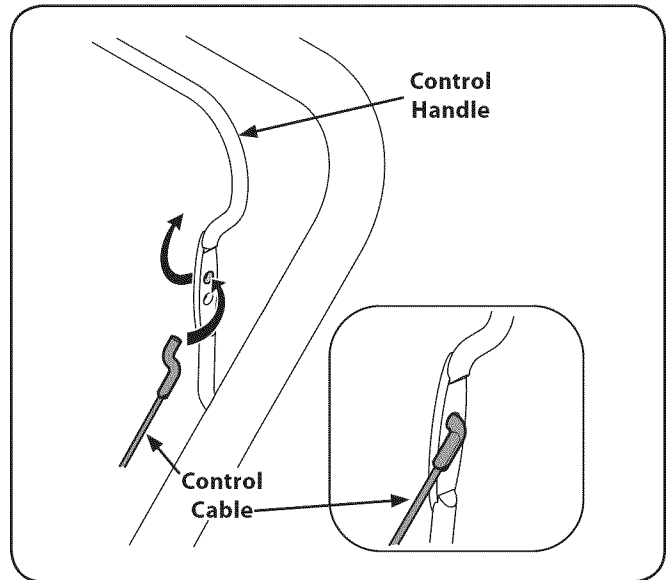

Figure 6-2

Test the snow thrower to see if there is a noticeable difference. If after the adjustment to the control cable the auger still hesitates when rotating, see the Service Section for instructions on replacing the belt.

### Chute Assembly

Refer to the Assembly and Set-Up section for instructions on adjusting the chute assembly.

## Maintenance

### Lubrication

Lubricate the pivot points on the control handle and the extension spring at the end of the control cable with a light oil once every season and before the snow thrower is put into storage at the end of the season.

### Off-Season Storage

If the snow thrower will not be used for 30 days or longer, follow the instructions below.

1. Store the equipment in a clean, dry area.
2. If storing the snow thrower in an unventilated area, rustproof the machine using a light oil or silicone to coat the snow thrower.
3. Clean the exterior of the engine and the snow thrower.
4. Lubricate pivot points on control handle and extension spring at end of control cable with a light oil.



**WARNING!** To prevent accidental start-up, shut off the engine and remove the key before performing any type of engine maintenance.

Periodic inspection and adjustment of the engine is essential if high level performance is to be maintained. Regular maintenance will also ensure a long service life. The required service intervals and the type of maintenance to be performed are described in the table below. Follow the hourly or calendar intervals, whichever occur first. More frequent service is required when operating in adverse conditions.

## Maintenance Schedule

Tasks	First 5 Hrs.	Each Use or Every 5 Hrs.	Every Season or 25 Hrs.	Every Season or 50 Hrs.	Every Season or 100 Hrs.	Service Dates
Check engine oil		●				
Change engine oil	●			●		
Check spark plug			●			
Service spark plug					●	
Clean exhaust area		●				

## Oil Recommendations

When adding oil to the engine, refer to the viscosity chart below (Fig. 7-1). Engine oil capacity is 600 ml (approx. 20 oz.). Do not over-fill. Use a 4-stroke, or an equivalent high detergent, premium quality motor oil certified to meet or exceed U.S. automobile manufacturer's requirements for service classification SG, SF. Motor oils classified SG, SF will show this designation on the container.

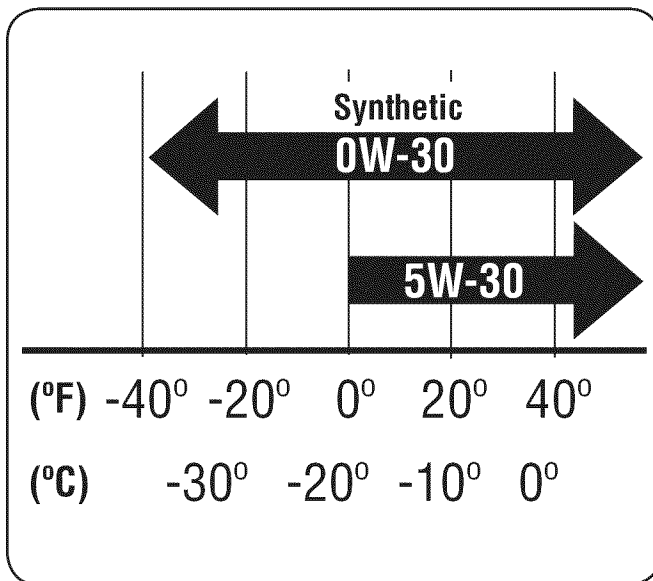

Figure 7-1

## Checking Engine Oil

1. Place the snow thrower on a flat, level surface.
2. Remove the oil filler cap/dipstick and wipe the dipstick clean. Ref. Fig. 3-4.
3. Insert the cap/dipstick into the oil filler neck, but DO NOT screw it in.
4. Remove the oil filler cap/dipstick. If the level is low, slowly add oil until oil level registers between high (H) and low (L). Ref. Fig. 3-4.

**NOTE:** Do not overfill. Overfilling the engine with oil may result in the engine smoking, hard starting or spark plug fouling.



**CAUTION:** DO NOT use non-detergent oil or 2-stroke engine oil. It could shorten the engine's service life.



## Changing Engine Oil

**NOTE:** Check the oil level before each use and after every five hours of operation to be sure the correct oil level is maintained. Refer to Checking Oil Level in the Operation Section

1. Drain fuel from the tank by running the engine until the fuel tank is empty. Be sure the fuel fill cap is secure.
2. Place a suitable oil collection container under the oil drain plug.
3. Remove the oil drain plug, Figure 7-2.

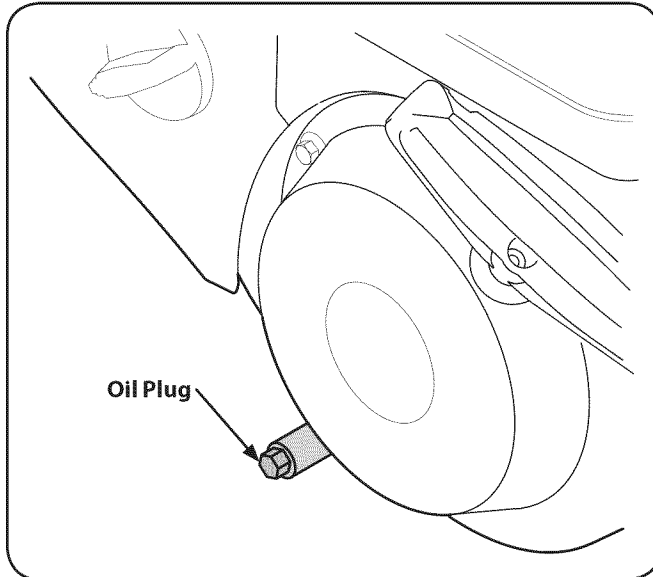

Figure 7-2

4. Tip the engine to drain oil into the container. Used oil must be disposed of at a proper collection center.
5. Reinstall the drain plug and tighten it securely.
6. Refill with the recommended oil and check the oil level, refer to Assembly & Set-Up Section for instructions.
7. Reinstall the oil filler cap/dipstick securely.



**CAUTION:** Thoroughly wash your hands with soap and water as soon as possible after handling used oil.

**NOTE:** Please dispose of used motor oil in a manner that is friendly to the environment. Take it to a recycling center or other collection center.

### Spark Plug



**WARNING!** DO NOT check for a spark with the spark plug removed. DO NOT crank the engine with the spark plug removed.



**WARNING!** If the engine has been running, the muffler will be very hot. Be careful not to touch the muffler.

To ensure proper engine operation, the spark plug must be properly gapped and free of deposits.

1. Remove the spark plug boot and use a spark plug wrench to remove the plug, Fig. 7-3.

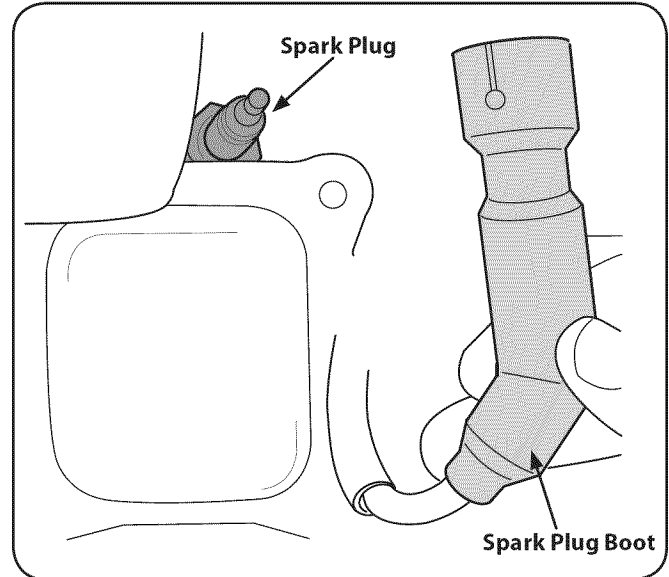

Figure 7-3

2. Visually inspect the spark plug. Discard the spark plug if there is any apparent wear, or if the insulator is cracked or chipped. Clean the spark plug with a wire brush if it is to be reused.
3. Measure the plug gap with a feeler gauge. Correct as necessary by bending the side electrode, Fig. 7-4. The gap should be set to .02-.03 inches (0.60-0.80 mm).

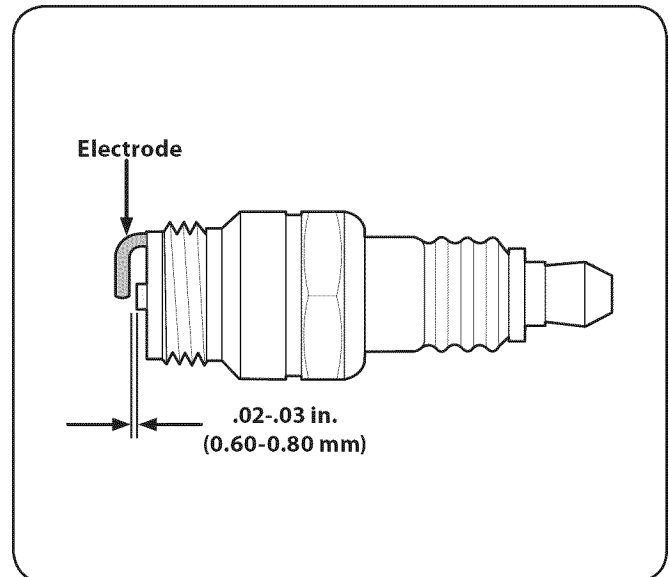

Figure 7-4

4. Check that the spark plug washer is in good condition and thread the spark plug in by hand to prevent cross-threading.

5. After the spark plug is seated, tighten with a spark plug wrench to compress the washer.

**NOTE:** When installing a new spark plug, tighten  $\frac{1}{2}$ -turn after the spark plug seats to compress the washer. When reinstalling a used spark plug, tighten  $\frac{1}{8}$ - to  $\frac{1}{4}$ -turn after the spark plug seats to compress the washer.



**CAUTION:** The spark plug must be tightened securely. A loose spark plug can become very hot and can damage the engine.

## Cleaning the Engine

If the engine has been running, allow it to cool for at least half an hour before cleaning. Periodically remove dirt build-up from engine.



**CAUTION:** Do not spray the engine with water to clean it because the water could contaminate the fuel. Using a garden hose or pressure washing equipment can also force water into the muffler opening. Water that passes through the muffler can enter the cylinder and cause damage.



**WARNING!** Accumulation of debris around the muffler could cause a fire. Inspect and clean before every use.

## Off-Season Storage

Engines stored over 30 days need to be drained of fuel to prevent deterioration and gum from forming in the fuel system or on essential carburetor parts. If the gasoline in your engine deteriorates during storage, you may need to have the carburetor, and other fuel system components, serviced or replaced.

1. Remove all fuel from the tank by running the engine until it stops.
2. Change the engine oil.
3. Remove the spark plug and pour approximately 1 oz. (30 ml) of clean engine oil into the cylinder. Pull the recoil starter several times to distribute the oil, and reinstall the spark plug.
4. Clean debris from around the engine, and under, around, and behind the muffler. Apply a light film of oil on any areas that are susceptible to rust.
5. Store in a clean, dry and well ventilated area away from any appliance that operates with a flame or pilot light, such as a furnace, water heater or clothes dryer. Avoid any area with a spark producing electric motor, or where power tools are operated.
6. If possible, avoid storage areas with high humidity.
7. Keep the engine level in storage. Tilting the engine can cause fuel or oil leakage.

## Replacing Belt

1. Remove the belt cover by removing the five hex screws that secure it to the frame. See Fig. 8-1.

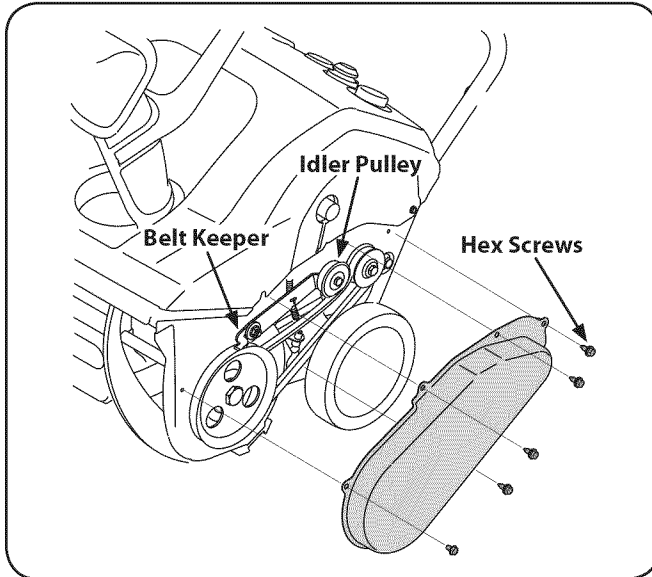

Figure 8-1

2. Remove the belt by grasping it from the bottom of the auger pulley and pulling outward.  
**NOTE:** Push down on the idler pulley to release the belt from under the belt keeper. See Fig. 8-1.

To replace the belt follow these instructions and refer to Fig. 8-2:

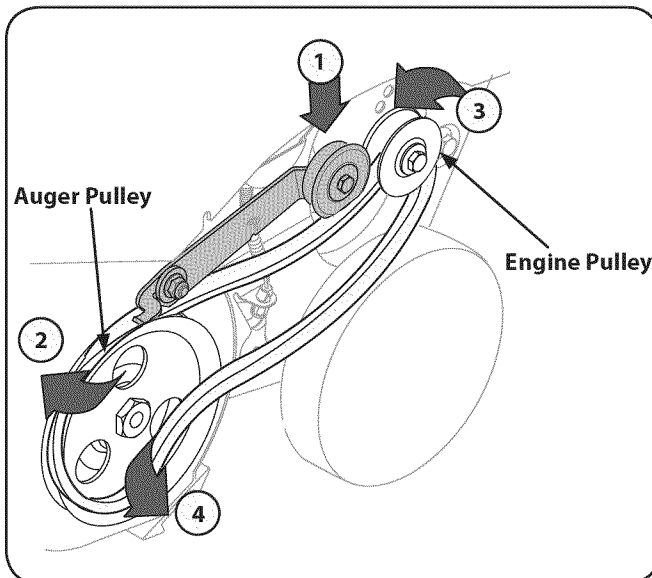

Figure 8-2

1. Push down on the idler pulley.
2. Position the belt on top of the auger pulley and under the belt keeper.

3. Route the belt around the engine pulley.
4. Push the belt over the bottom of the auger pulley.
5. Reinstall the belt cover removed earlier.

## Replacing Auger Paddles

The snow thrower auger's rubber paddles are subject to wear and should be replaced if any signs of excessive wear are present.



**CAUTION:** Do NOT allow the auger's rubber paddles to wear to the point where portions of the metal auger itself can come in contact with the pavement. Doing so can result in serious damage to your snow thrower.

To change the rubber paddles, proceed as follows:

1. Remove the existing rubber paddles by unthreading the self-tapping screws which secure them to the auger. See Fig. 8-3.

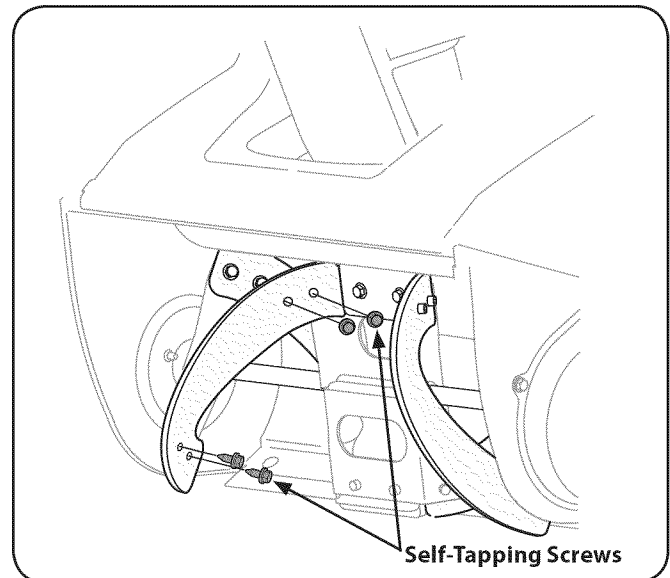

Figure 8-3

2. Secure the replacement rubber paddles to the auger using the hardware removed earlier.

## Replacing Shave Plate

The shave plate is attached to the bottom of the auger housing and is subject to wear. It should be checked periodically. There are two wearing edges and the shave plate can be reversed.

1. Remove the four carriage bolts and hex lock nuts which attach it to the snow thrower housing.
2. Install the new shave plate, making sure the heads of the carriage bolts are on the inside of the housing.
3. Adjust the shave plate as instructed in the Maintenance & Adjustments Section.
4. Tighten securely once adjusted.

Problem	Cause	Remedy
Engine Fails to start	<ol style="list-style-type: none"> <li>1. Fuel tank empty, or stale fuel.</li> <li>2. Blocked fuel line.</li> <li>3. Key not inserted all the way.</li> <li>4. Spark plug wire disconnected.</li> <li>5. Faulty spark plug.</li> <li>6. Engine not primed.</li> <li>7. Engine flooded from excessive priming.</li> </ol>	<ol style="list-style-type: none"> <li>1. Fill tank with clean fresh gasoline.</li> <li>2. Clean fuel line.</li> <li>3. Insert key all the way.</li> <li>4. Connect wire to spark plug.</li> <li>5. Clean spark plug, readjust gap, or replace.</li> <li>6. Prime engine five times.</li> <li>7. Wait at least ten minutes before starting.</li> </ol>
Engine running erratically/ inconsistent RPM (hunting or surging)	<ol style="list-style-type: none"> <li>1. Engine running on choke.</li> <li>2. Fuel line blocked, or stale fuel.</li> <li>3. Water or dirt in fuel system.</li> <li>4. Carburetor out of adjustment.</li> <li>5. Over-governed engine.</li> </ol>	<ol style="list-style-type: none"> <li>1. Move choke lever to RUN position.</li> <li>2. Clean fuel line and fill tank with fresh, clean gasoline.</li> <li>3. Run engine until it stops. Refill with fresh fuel.</li> <li>4. Contact an authorized service center.</li> <li>5. Contact an authorized service center.</li> </ol>
Engine overheats	<ol style="list-style-type: none"> <li>1. Carburetor out of adjustment.</li> </ol>	<ol style="list-style-type: none"> <li>1. Contact an authorized service center.</li> </ol>
Loss of power	<ol style="list-style-type: none"> <li>1. Spark plug wire loose.</li> <li>2. Vent in gas cap plugged.</li> </ol>	<ol style="list-style-type: none"> <li>1. Firmly connect spark plug wire.</li> <li>2. Clear vent.</li> </ol>
Excessive vibration	<ol style="list-style-type: none"> <li>1. Loose parts or damaged auger.</li> </ol>	<ol style="list-style-type: none"> <li>1. Stop engine immediately and disconnect spark plug wire. Check for possible damage. Tighten all bolts and nuts. Repair as needed. If the problem persists, take snow thrower to an authorized service dealer.</li> </ol>
Snow thrower fails to self-propel	<ol style="list-style-type: none"> <li>1. Auger control cable out of adjustment.</li> <li>2. Auger drive belt loose or damaged.</li> </ol>	<ol style="list-style-type: none"> <li>1. Adjust auger control cable as shown in Maintenance &amp; Adjustments section.</li> <li>2. Replace auger drive belt.</li> </ol>
Augers continue to rotate	<ol style="list-style-type: none"> <li>1. Auger control cable out of adjustment.</li> </ol>	<ol style="list-style-type: none"> <li>1. Adjust auger control cable as shown in Maintenance &amp; Adjustments section.</li> </ol>
Unit fails to discharge snow	<ol style="list-style-type: none"> <li>1. Chute assembly clogged.</li> <li>2. Foreign object lodged in auger.</li> <li>3. Auger control cable out of adjustment.</li> <li>4. Auger belt loose or damaged.</li> </ol>	<ol style="list-style-type: none"> <li>1. Stop engine and disconnect spark plug wire. Clean chute and inside of auger housing with clean-out tool or stick.</li> <li>2. Stop engine immediately and disconnect the spark plug wire. Remove object from auger.</li> <li>3. Adjust auger control cable.</li> <li>4. Replace auger belt.</li> </ol>
Engine fails to start	<ol style="list-style-type: none"> <li>1. Extension cord not connected (when using electric start button, on models so equipped)</li> </ol>	<ol style="list-style-type: none"> <li>1. Connect one end of the extension cord to the electric starter outlet and the other end to a three-prong 120-volt, grounded, AC outlet.</li> </ol>

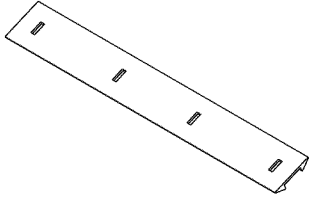
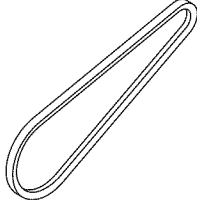
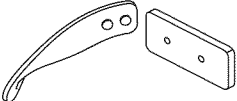
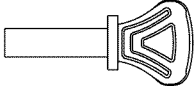
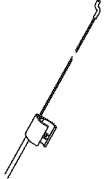
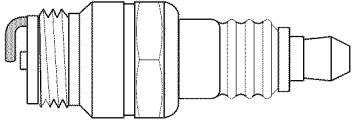
Component	Part Number and Description
	731-1033      Shave Plate
	954-04204      Belt V-Type
	735-04032      Spiral Crescent 735-04033      Rubber Paddle 753-04472      Replacement Kit (includes 4 crescents, 2 paddles and hardware)
	731-05632      Key
	746-04237      Clutch Cable
	951-10292      Spark Plug

Phone (800) 800-7310 to order replacement parts or a complete Parts Manual (have your full model number and serial number ready).  
 Parts Manual downloads are also available free of charge at [www.mtdproducts.com](http://www.mtdproducts.com).

**MTD CONSUMER GROUP INC (MTD), the California Air Resources Board (CARB)  
and the United States Environment Protection Agency (U. S. EPA)**

**Emission Control System Warranty Statement  
(Owner's Defect Warranty Rights and Obligations)**

EMISSION CONTROL SYSTEM COVERAGE IS APPLICABLE TO CERTIFIED ENGINES PURCHASED IN CALIFORNIA IN 2005 AND THEREAFTER, WHICH ARE USED IN CALIFORNIA, AND TO CERTIFIED MODEL YEAR 2005 AND LATER ENGINES WHICH ARE PURCHASED AND USED ELSEWHERE IN THE UNITED STATES.

California and elsewhere in the United States Emission Control Defects Warranty Coverage

The California Air Resources Board (CARB), U. S. EPA and MTD are pleased to explain the emissions control system warranty on your model year 2006 and later small off-road engine. In California, new small off-road engines must be designed, built and equipped to meet the States anti-smog standards. Elsewhere in the United States, new non-road, spark-ignition engines certified for model 2005 and later, must meet similar standards set forth by the U. S. EPA. MTD must warranty the emission control system on your engine for the period of time listed below, provided there has been no abuse, neglect or improper maintenance of your small off-road engine.

Your emission control system may include parts such as the carburetor, fuel-injection system, the ignition system, and catalytic converter, fuel tanks, fuel lines, fuel caps, valves, canisters, filters, vapor hoses, clamps, connectors, and other associated emission-related components.

Where a warrantable condition exists, MTD will repair your small off-road engine at no cost to you including diagnosis, parts and labor.

**MANUFACTURER'S WARRANTY COVERAGE:**

This emissions control system is warranted for two years. If any emission-related part on your engine is defective, the part will be repaired or replaced by MTD.

**OWNER'S WARRANTY RESPONSIBILITIES:**

As the small off-road engine owner, you are responsible for the performance of the required maintenance listed in your Owner's Manual. MTD recommends that you retain all your receipts covering maintenances on your small off-road engine, but MTD can not deny warranty solely for the lack of receipts or for your failure to ensure the performance to all scheduled maintenance.

As the small off-road engine owner, you should however be aware that MTD may deny your warranty coverage if your small off-road engine or part has failed due to abuse, neglect, improper maintenance or unapproved modifications.

You are responsible for presenting your small off-road engine to an Authorized MTD Service Dealer as soon as a problem exists. The warranted repairs should be completed in a reasonable amount of time, not to exceed 30 days.

If you have any questions regarding your warranty rights and responsibilities, you should contact a MTD Service Representative at 1-800-800-7310 and address is MTD CONSUMER GROUP, P.O. Box 361131, Cleveland OH, 44136-0019.

**DEFECTS WARRANTY REQUIREMENTS FOR 1995 AND LATER SMALL OFF-ROAD ENGINES:**

This section applies to 1995 and later small off-road engines. The warranty period begins on the date the engine or equipment is delivered to an ultimate purchaser.

(a) General Emissions Warranty Coverage

MTD must warrant to the ultimate purchaser and each subsequent purchaser that the engine is:

- (1) Designed, built, and equipped so as to conform with all applicable regulations adopted by the Air Resources Board pursuant to its authority in Chapters 1 and 2, Part 5, Division 26 of the Health and Safety Code; and
- (2) Free from defects in materials and workmanship that cause the failure of a warranted part to be identical in all material respects to the part as described in the engine manufacturer's application for certification for a period of two years.

(b) The warranty on emissions-related parts will be interpreted as follows:

- (1) Any warranted part that is not scheduled for replacement as required maintenance in the written instructions required by Subsection (c) must be warranted for the warranty period defined in Subsection (a)(2). If any such part fails during the period of warranty coverage, it must be repaired or replaced by MTD according to Subsection (4) below. Any such part repaired or replaced under the warranty must be warranted for the remaining warranty period.
- (2) Any warranted part that is scheduled only for regular inspection in the written instructions required by Subsection (c) must be warranted for the warranty period defined in Subsection (a)(2). A statement in such written instructions to the effect of "repair or replace as necessary" will not reduce the period of warranty coverage. Any such part repaired or replaced under warranty must be warranted for the remaining warranty period.
- (3) Any warranted part that which is scheduled for replacement as required maintenance in the written instructions required by Subsection (c) must be warranted for the period of time prior to the first scheduled replacement point for that part. If the part fails prior to the first scheduled replacement, the part must be repaired or replaced by MTD according to Subsection (4) below. Any such part repaired or replaced under warranty must be warranted for the remainder of the period prior to the first scheduled replacement point for the part.

---

(4) Repair or replacement of any warranted part under the warranty provisions of this article must be performed at no charge to the owner at a warranty station.

(5) Notwithstanding the provisions of Subsection (4) above, warranty services or repairs must be provided at all MTD distribution centers that are franchised to service the subject engines.

(6) The owner must not be charged for diagnostic labor that leads to the determination that a warranted part is in fact defective, provided that such diagnostic work is performed at a warranty station.

(7) The engine manufacturer is liable for damages to other engine components proximately caused by a failure under warranty of any warranted part.

(8) Throughout the engine's warranty period defined in Subsection (a)(2), MTD will maintain a supply of warranted parts sufficient to meet the expected demand for such parts.

(9) Any replacement part may be used in the performance of any warranty maintenance or repairs and must be provided without charge to the owner. Such use will not reduce the warranty obligations of MTD.

(10) Add-on or modified parts that are not exempted by the Air Resources Board may not be used. The use of any non-exempted add-on or modified parts shall be grounds for disallowing a warranty claim made in accordance with this article. The engine manufacturer shall not be liable under this article to warrant failures of warranted parts caused by the use of non-exempted add-on or modified part.

(c) MTD will include a copy of the following emission warranty parts list with each new engine, using those portions of the list applicable to the engine.

(1) Fuel Metering System

- Cold start enrichment system (soft choke)
- Carburetor and internal parts
- Fuel Pump
- Fuel Tank

(2) Air Induction System

- Air cleaner
- Intake manifold

(3) Ignition System

- Spark plug(s)
- Magneto Ignition System

(4) Exhaust System

- Catalytic converter
- SAI (Reed valve)

(5) Miscellaneous Items Used in Above System

- Vacuum, temperature, position, time sensitive valves and switches
- Connectors and assemblies

(6) Evaporative control

- Fuel Hose certified for ARB evaporative emission of 2006.
- Fuel Hose Clamps
- Tethered fuel cap
- Carbon canister
- Vapor lines

# MANUFACTURER'S LIMITED WARRANTY FOR



The limited warranty set forth below is given by MTD LLC with respect to new merchandise purchased and used in the United States and/or its territories and possessions, and by MTD Products Limited with respect to new merchandise purchased and used in Canada and/or its territories and possessions (either entity respectively, "MTD").

"MTD" warrants this product (excluding its *Normal Wear Parts and Attachments* as described below) against defects in material and workmanship for a period of two (2) years commencing on the date of original purchase and will, at its option, repair or replace, free of charge, any part found to be defective in materials or workmanship. This limited warranty shall only apply if this product has been operated and maintained in accordance with the Operator's Manual furnished with the product, and has not been subject to misuse, abuse, commercial use, neglect, accident, improper maintenance, alteration, vandalism, theft, fire, water, or damage because of other peril or natural disaster. Damage resulting from the installation or use of any part, accessory or attachment not approved by MTD for use with the product(s) covered by this manual will void your warranty as to any resulting damage.

*Normal Wear Parts* are warranted to be free from defects in material and workmanship for a period of thirty (30) days from the date of purchase. Normal wear parts include, but are not limited to items such as: batteries, belts, blades, blade adapters, tines, grass bags, wheels, rider deck wheels, seats, snow thrower skid shoes, friction wheels, shave plates, auger spiral rubber, engine oil, air filters, spark plugs and tires.

*Attachments* — MTD warrants attachments for this product against defects in material and workmanship for a period of one (1) year, commencing on the date of the attachment's original purchase or lease. Attachments include, but are not limited to items such as: grass collectors and mulch kits.

**HOW TO OBTAIN SERVICE:** Warranty service is available, WITH PROOF OF PURCHASE, through your local authorized service dealer. To locate the dealer in your area:

## In the U.S.A.

Check your Yellow Pages, or contact MTD LLC at P.O. Box 361131, Cleveland, Ohio 44136-0019, or call 1-800-800-7310, 1-330-220-4683 or log on to our Web site at [www.mtdproducts.com](http://www.mtdproducts.com).

## In Canada

Contact MTD Products Limited, Kitchener, ON N2G 4J1, or call 1-800-668-1238 or log on to our Web site at [www.mtdcanada.com](http://www.mtdcanada.com).

This limited warranty does **not** provide coverage in the following cases:

- a. Log splitter pumps, valves, and cylinders have a separate one-year warranty.
- b. Routine maintenance items such as lubricants, filters, blade sharpening, tune-ups, brake adjustments, clutch adjustments, deck adjustments, and normal deterioration of the exterior finish due to use or exposure.

- c. Service completed by someone other than an authorized service dealer.
- d. MTD does not extend any warranty for products sold or exported outside of the United States and/or Canada, and their respective possessions and territories, except those sold through MTD's authorized channels of export distribution.
- e. Replacement parts that are not genuine MTD parts.
- f. Transportation charges and service calls.
- g. MTD does not warrant this product for commercial use.

**No implied warranty, including any implied warranty of merchantability of fitness for a particular purpose, applies after the applicable period of express written warranty above as to the parts as identified. No other express warranty, whether written or oral, except as mentioned above, given by any person or entity, including a dealer or retailer, with respect to any product, shall bind MTD. During the period of the warranty, the exclusive remedy is repair or replacement of the product as set forth above.**

**The provisions as set forth in this warranty provide the sole and exclusive remedy arising from the sale. MTD shall not be liable for incidental or consequential loss or damage including, without limitation, expenses incurred for substitute or replacement lawn care services or for rental expenses to temporarily replace a warranted product.**

Some states do not allow the exclusion or limitation of incidental or consequential damages, or limitations on how long an implied warranty lasts, so the above exclusions or limitations may not apply to you.

In no event shall recovery of any kind be greater than the amount of the purchase price of the product sold. **Alteration of safety features of the product shall void this warranty.** You assume the risk and liability for loss, damage, or injury to you and your property and/or to others and their property arising out of the misuse or inability to use the product.

This limited warranty shall not extend to anyone other than the original purchaser or to the person for whom it was purchased as a gift.

**HOW STATE LAW RELATES TO THIS WARRANTY:** This limited warranty gives you specific legal rights, and you may also have other rights which vary from state to state.

**IMPORTANT:** Owner must present Original Proof of Purchase to obtain warranty coverage.

**MTD LLC, P.O. BOX 361131 CLEVELAND, OHIO 44136-0019; Phone: 1-800-800-7310, 1-330-220-4683  
MTD Canada Limited - KITCHENER, ON N2G 4J1; Phone 1-800-668-1238**