

Operator's Manual

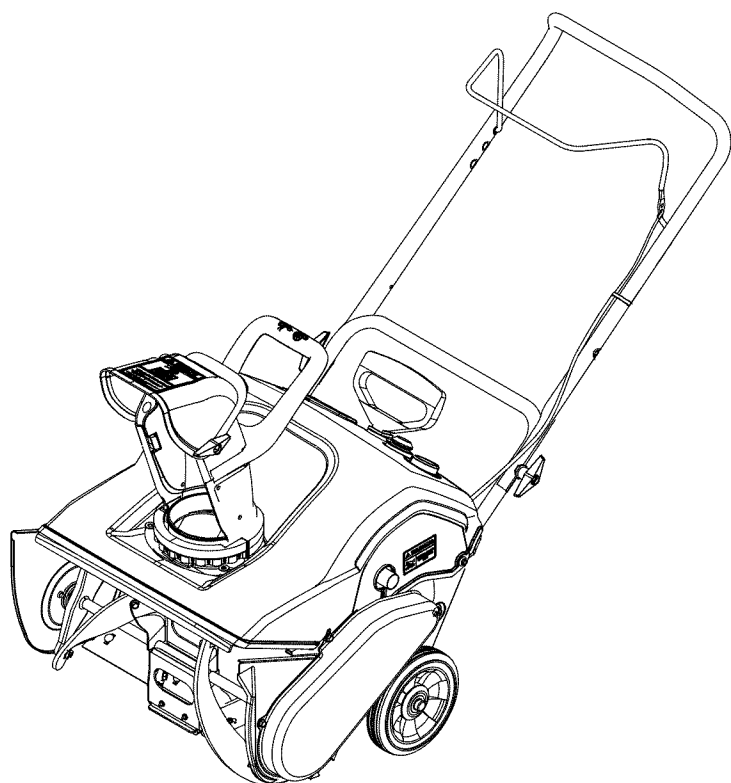

Single-Stage Snow Thrower

Models **262**
S235
S265

IMPORTANT: Read safety rules and instructions carefully before operating equipment.

Warning: This unit is equipped with an internal combustion engine and should not be used on or near any unimproved forest-covered, brush-covered or grass-covered land unless the engine's exhaust system is equipped with a spark arrester meeting applicable local or state laws (if any). If a spark arrester is used, it should be maintained in effective working order by the operator. In the State of California the above is required by law (Section 4442 of the California Public Resources Code). Other states may have similar laws. Federal laws apply on federal lands. A spark arrester for the muffler is available through your nearest engine authorized service dealer or contact the service department, P.O. Box 361131 Cleveland, Ohio 44136-0019.

MTD LLC, P.O. BOX 361131 CLEVELAND, OHIO 44136-0019

PRINTED IN U.S.A.

FORM NO. 769-01200.
(5/21/2004)

TABLE OF CONTENTS

Content	Page	Content	Page
Customer Support	2	Maintenance	8
Important Safe Operation Practices	3	Service & Adjustments	8
Assembly	5	Accessories & Kits	11
Controls	6	Illustrated Parts List	12
Operation	7	Warranty	Back Cover

FINDING MODEL NUMBER

This Operator's Manual is an important part of your new snow thrower. It will help you assemble, prepare and maintain the unit for best performance. Please read and understand what it says.



Before you start assembling your new equipment, please locate the model plate on the equipment and copy the information from it in the space provided below. A sample model plate is also given below. You can locate the model plate by standing behind the unit and looking at the rear of the snow thrower frame. This information will be necessary to use the manufacturer's web site and/or help from the Customer Support Department or an authorized service dealer.



Copy the model number here: _____

Copy the serial number here: _____

CUSTOMER SUPPORT

Please do NOT return the unit to the retailer from where it was purchased, without first contacting Customer Support.

If you have difficulty assembling this product or have any questions regarding the controls, operation or maintenance of this unit, you can seek help from the experts. Choose from the options below:

	<p>Visit mtdproducts.com for many useful suggestions. Click on Customer Support button and you will get the four options reproduced here. Click on the appropriate button and help is immediately available.</p> <div style="display: flex; justify-content: space-between; align-items: center;"> <div style="width: 45%; text-align: center;"> <p><i>The answer you are looking for could be just a mouse click away!</i></p> </div> <div style="width: 30%; border: 1px solid black; padding: 5px;"> <div style="border-bottom: 1px solid black; padding: 2px;"> <p>Find Answers Click here to search our knowledge base. Search by product, keyword, or phrase.</p> </div> <div style="border-bottom: 1px solid black; padding: 2px;"> <p>My Stuff Login to check the status of your questions, modify your inquiries, or update your personal profile.</p> </div> <div style="border-bottom: 1px solid black; padding: 2px;"> <p>Service Locator Need local assistance? Click here to find authorized service centers in your area.</p> </div> <div style="padding: 2px;"> <p>Manuals Online Need a manual and/or parts list? Download literature from recent model years.</p> </div> </div> <div style="width: 45%; text-align: center;"> <p><i>The answer you are looking for could be just a mouse click away!</i></p> </div> </div>
	<p>If you prefer to reach a Customer Support Representative, please call 1(800) 800-7310.</p>
	<p>The engine manufacturer is responsible for all engine-related issues with regards to performance, power-rating, specifications, warranty and service. Please refer to the engine manufacturer's Owner's/Operator's Manual, packed separately with your unit, for more information.</p>

SECTION 1: IMPORTANT SAFE OPERATION PRACTICES



WARNING: This symbol points out important safety instructions which, if not followed, could endanger the personal safety and/or property of yourself and others. Read and follow all instructions in this manual before attempting to operate this machine. Failure to comply with these instructions may result in personal injury. When you see this symbol—**heed its warning.**



WARNING: Engine Exhaust, some of its constituents, and certain vehicle components contain or emit chemicals known to State of California to cause cancer and birth defects or other reproductive harm.



DANGER: This machine was built to be operated according to the rules for safe operation in this manual. As with any type of power equipment, carelessness or error on the part of the operator can result in serious injury. This machine is capable of amputating hands and feet and throwing objects. Failure to observe the following safety instructions could result in serious injury or death.

Training

1. Read, understand, and follow all instructions on the machine and in the manual(s) before attempting to assemble and operate. Keep this manual in a safe place for future and regular reference and for ordering replacement parts.
2. Be familiar with all controls and their proper operation. Know how to stop the machine and disengage them quickly.
3. Never allow children under 14 years old to operate this machine. Children 14 years old and over should read and understand the operation instructions and safety rules in this manual and should be trained and supervised by a parent.
4. Never allow adults to operate this machine without proper instruction.
5. Thrown objects can cause serious personal injury. Plan your snow throwing pattern to avoid discharge of material toward roads, bystanders and the like.
6. Keep bystanders, helpers, pets and children at least 75 feet from the machine while it is in operation. Stop machine if anyone enters the area.
7. Exercise caution to avoid slipping or falling, especially when operating in reverse.
8. Let engine and machine adjust to outdoor temperature before starting to clear snow.
9. To avoid personal injury or property damage use extreme care in handling gasoline. Gasoline is extremely flammable and the vapors are explosive. Serious personal injury can occur when gasoline is spilled on yourself or your clothes which can ignite. Wash your skin and change clothes immediately.
 - a. Use only an approved gasoline container.
 - b. Extinguish all cigarettes, cigars, pipes and other sources of ignition.
 - c. Never fuel machine indoors.
 - d. Never remove gas cap or add fuel while the engine is hot or running.
 - e. Allow engine to cool at least two minutes before refueling.
 - f. Never over fill fuel tank. Fill tank to no more than ½ inch below bottom of filler neck to provide space for fuel expansion.
 - g. Replace gasoline cap and tighten securely.
 - h. If gasoline is spilled, wipe it off the engine and equipment. Move machine to another area. Wait 5 minutes before starting the engine.
 - i. Never store the machine or fuel container inside where there is an open flame, spark or pilot light (e.g. furnace, water heater, space heater, clothes dryer etc.).
 - j. Allow machine to cool at least 5 minutes before storing.

Preparation

1. Thoroughly inspect the area where the equipment is to be used. Remove all door mats, newspapers, sleds, boards, wires and other foreign objects which could be tripped over or thrown by the auger/impeller.
2. Always wear safety glasses or eye shields during operation and while performing an adjustment or repair to protect your eyes. Thrown objects which ricochet can cause serious injury to the eyes.
3. Do not operate without wearing adequate winter outer garments. Do not wear jewelry, long scarves or other loose clothing which could become entangled in moving parts. Wear footwear which will improve footing on slippery surfaces.
4. Use a grounded three wire extension cord and receptacle for all units with electric start engines.
5. Adjust collector housing height to clear gravel or crushed rock surfaces.
6. Disengage the control handle before starting the engine.
7. Never attempt to make any adjustments while engine is running, except where specifically recommended in the operator's manual.

Operation

1. Do not put hands or feet near rotating parts, in the auger housing or discharge chute. Contact with the rotating parts can amputate hands and feet.
2. The auger control handle is a safety device. Never bypass its operation. Doing so, makes the machine unsafe and may cause personal injury.
3. The control handle must operate easily in both directions and automatically return to the disengaged position when released.
4. Never operate with a missing or damaged discharge chute. Keep all safety devices in place and working.
5. Never run an engine indoors or in a poorly ventilated area. Engine exhaust contains carbon monoxide, an odorless and deadly gas.

6. Do not operate machine while under the influence of alcohol or drugs.
7. Muffler and engine become hot and can cause a burn. Do not touch.
8. Exercise extreme caution when operating on or crossing gravel surfaces. Stay alert for hidden hazards or traffic.
9. Exercise caution when changing direction and while operating on slopes.
10. Plan your snow throwing pattern to avoid discharge towards windows, walls, cars etc. To avoid property damage or personal injury caused by a ricochet.
11. Never direct discharge at children, bystanders and pets or allow anyone in front of the machine.
12. Do not overload machine capacity by attempting to clear snow at too fast of a rate.
13. Never operate this machine without good visibility or light. Always be sure of your footing and keep a firm hold on the handles. Walk, never run.
14. Disengage power to the auger/impeller when transporting or not in use.
15. Never operate machine at high transport speeds on slippery surfaces. Look down and behind and use care when in reverse.
16. If the machine should start to vibrate abnormally, stop the engine, disconnect the spark plug and ground it against the engine. Inspect thoroughly for damage. Repair any damage before starting and operating.
17. Disengage the control handle and stop engine before you leave the operating position (behind the handles). Wait until the auger comes to a complete stop before unclogging the discharge chute, making any adjustments, or inspections.
18. Never put your hand in the discharge or collector openings. Always use a clearing tool to unclog the discharge opening.
19. Use only attachments and accessories approved by the manufacturer.
20. If situations occur which are not covered in this manual, use care and good judgment. Contact your dealer or telephone 1-800-800-7310 for assistance and the name of your nearest servicing dealer.

Maintenance And Storage

1. Never tamper with safety devices. Check their proper operation regularly.
2. Disengage the control handle and stop engine. Wait until the auger/impeller come to a complete stop. Disconnect the spark plug wire and ground against the engine to prevent unintended starting before cleaning, repairing, or inspecting.
3. Check bolts, and screws for proper tightness at frequent intervals to keep the machine in safe working condition. Also, visually inspect machine for any damage.
4. Do not change the engine governor setting or over-speed the engine. The governor controls the maximum safe operating speed of the engine.
5. Snow thrower shave plates and skid shoes are subject to wear and damage. For your safety protection, frequently check all components and replace with original equipment manufacturer's (O.E.M.) parts only. "Use of parts which do not meet the original equipment specifications may lead to improper performance and compromise safety!"
6. Check controls periodically to verify they engage and disengage properly and adjust, if necessary. Refer to the adjustment section in this operator's manual for instructions.
7. Maintain or replace safety and instruction labels, as necessary.
8. Observe proper disposal laws and regulations for gas, oil, etc. to protect the environment.
9. Prior to storing, run machine a few minutes to clear snow from machine and prevent freeze up of auger/impeller.
10. Never store the machine or fuel container inside where there is an open flame, spark or pilot light such as a water heater, furnace, clothes dryer etc.
11. Always refer to the operator's manual for proper instructions on off-season storage.

Your Responsibility:

- Restrict the use of this power machine to persons who read, understand and follow the warnings and instructions in this manual and on the machine.

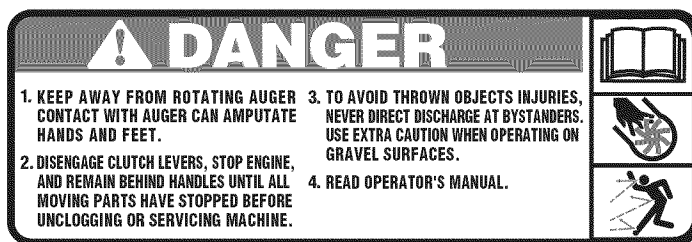

SECTION 2: ASSEMBLING YOUR SNOW THROWER

NOTE: This Operator's Manual covers several models. **Snow thrower features vary by model.** Not all features discussed in this manual are applicable to all snow thrower models.

Contents of Carton

Carton contents are listed below:

- Two Ignition Keys
- Bottle of 2 cycle oil
- Extension Cord (select models only)

NOTE: All references to left or right side of the snow thrower is from the operating position only.



WARNING: Disconnect the spark plug wire and ground it against the engine to prevent unintended starting.

Positioning the Upper Handle

- Remove packing material, if present.
- Making sure not to pinch the cable in the process, pivot the upper handle into the operating position as illustrated until it clicks into place.
- Tighten the wing knobs to secure the handle in place.

Assembling the Discharge Chute

For shipping reasons, the snow thrower has been packaged with the upper chute pivoted all the way down. To pivot it upward, proceed as follows:

- Turn the chute until the chute opening is facing straight ahead.
- Remove the wing knob, flat washer and carriage bolt from the lower chute.
- Pivot the upper chute upward **over the lip on the lower chute** so that there is **NO** gap between the upper chute and the lower chute.
- Resecure with the hardware just removed.

IMPORTANT: Do not use the chute handle to lift the snow thrower.

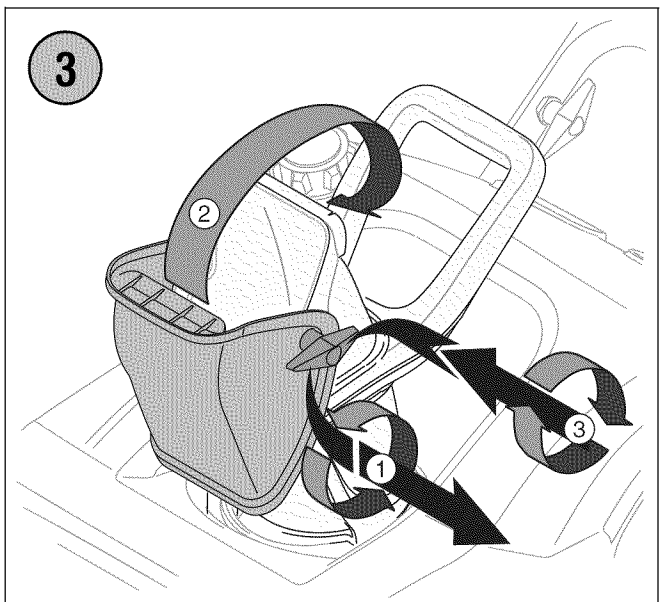
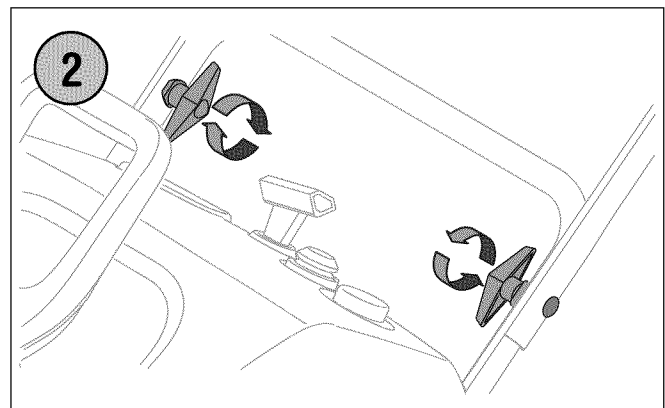
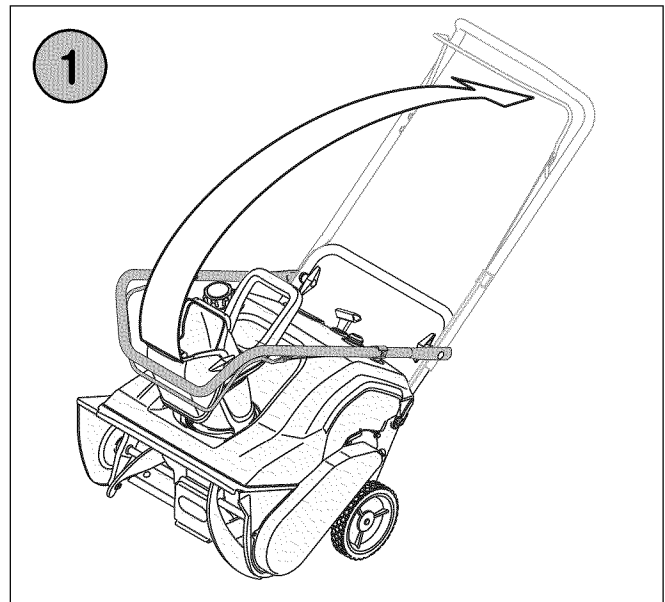
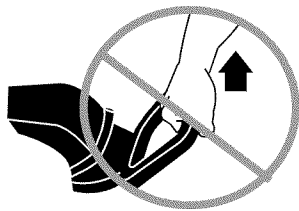

SECTION 3: KNOW YOUR SNOW THROWER

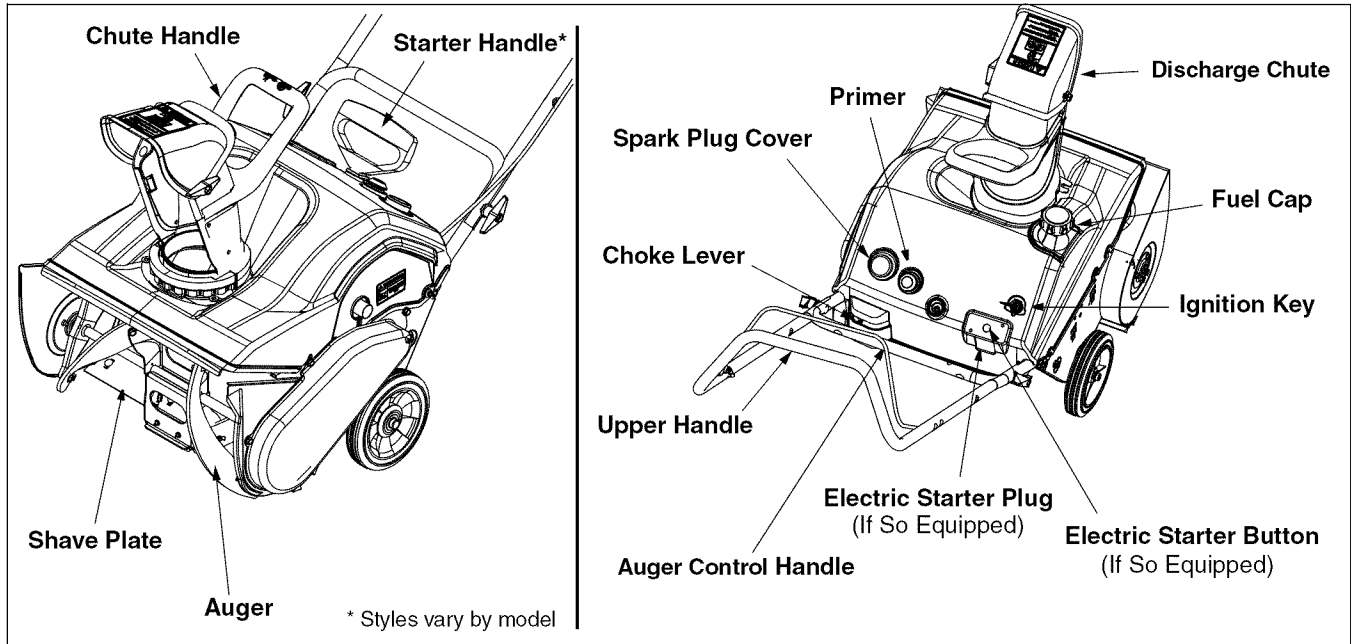

Figure 1

IMPORTANT: This unit runs on a **mixture of gasoline and oil**. Do NOT operate the snow thrower without first reading the *Tecumseh* engines operator's manual for instructions regarding proper fuel and engine oil.

Choke Lever



Activating the choke control closes the choke plate on the carburetor and aids in starting the engine. Refer to the engine manual packed with the snow thrower for more detailed instructions regarding the choke.

Primer

Depressing the primer forces fuel directly into the engine's carburetor to aid in cold-weather starting. Refer to the engine manual packed with the snow thrower for more detailed instructions regarding the primer.

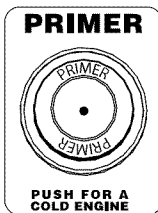

Ignition Key

The ignition key **must** be present, inserted in the key switch, and in the "ON" position for the engine to start.

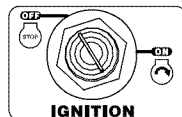

Starter Handle

The starter handle is used to manually start the engine.

Electric Starter Button (If so equipped)

Pressing the electric starter button engages the engine's electric starter when plugged into a 120V power source

Electric Starter Plug (If so equipped)

Requires use of a two-prong outdoor extension cord (packed with the snow thrower) and a 120V power source/wall outlet.

Spark Plug Cover

Remove the spark plug cover to access the engine's spark plug located beneath it.

Auger

When engaged, the augers rotation draws snow into the auger housing and throws it out the discharge chute. The rubber paddles on the augers also aid in propelling the snow thrower as they come in contact with the pavement.

Auger Control Handle

Located on the upper handle, the auger control handle is used to engage and disengage drive to the auger. Squeeze the control handle against the upper handle to engage the auger; release it to disengage.

Discharge Chute / Chute Handle

Rotate the discharge chute to the left or right using the chute handle. The pitch of the discharge chute controls the angle at which the snow is thrown. Loosen the wing knob on the side of the discharge chute before pivoting the discharge chute upward or downward. Retighten the knob once the desired position has been achieved.

Shave Plate

The shave plate maintains contact with the pavement as the snow thrower is propelled, allowing the snow close to the pavement's surface to be discharged.

SECTION 4: OPERATING YOUR SNOW THROWER



WARNING: Before starting the engine, read, understand, and follow all instructions and warnings on the machine and in this manual before operating.

Fuel And Oil Mixture



WARNING: Use extreme care when handling gasoline. Gasoline is extremely flammable and the vapors are explosive. Never fuel machine indoors or while the engine is hot or running. Extinguish cigarettes, cigars, pipes and other sources of ignition.

Your snow thrower is equipped with a two-cycle engine that requires a mixture of gasoline and two cycle engine oil at a ratio of **50:1**. Refer to the *Tecumseh* engines operator's manual for detailed instructions regarding oil and gasoline for your snow thrower's engine.

IMPORTANT: Do NOT operate the snow thrower without the fuel cap securely in place on the fuel tank.

Positioning the Discharge Chute

- Loosen the wing knob found on the left side of the discharge chute and pivot the upper chute upward or downward to the desired pitch. Retighten the wing knob before operating the snow thrower.
- Rotate the discharge chute to the left or right using the chute handle. See Figure 2.

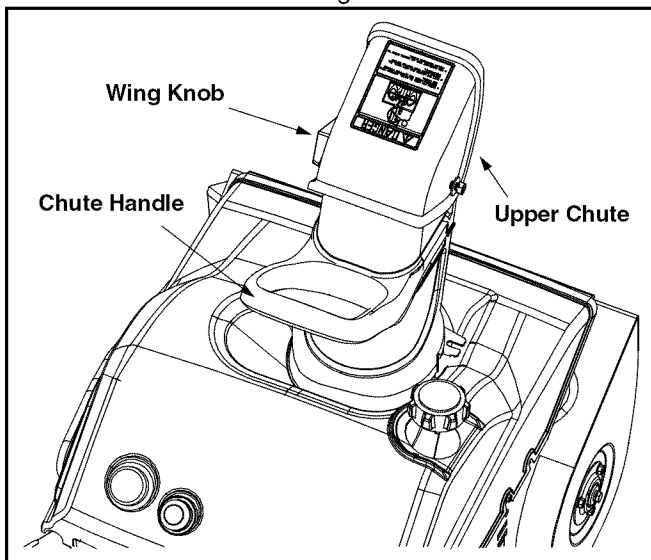

Figure 2

Starting the Engine

- Refer to the *Engines* manual packed with the snow thrower for detailed instructions regarding starting the engine.

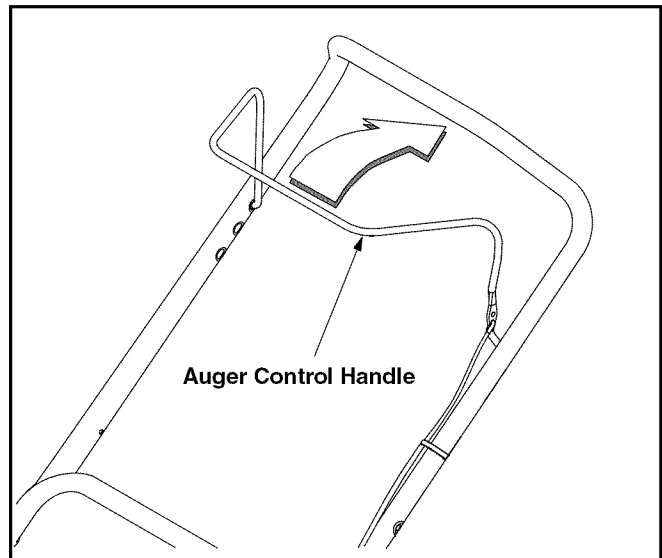

Figure 3

NOTE: For more efficient snow clearing, discharge snow downwind whenever possible.



WARNING: Never operate the snow thrower with bystanders in front of or near the discharge chute opening.

- Engage the auger by squeezing the control handle against the upper handle. See Figure 3.
- Lift up slightly on the handle to allow the rubber paddles on the auger to contact the pavement and propel the snow thrower forward.

IMPORTANT: Excessive upward pressure on the handle will result in premature wear on the rubber auger paddles or possible damage or marking of pavement. Resulting wear would not be covered by warranty.

- As the snow thrower starts to move, maintain a firm hold on the handle, and guide the snow thrower along the path to be cleared.
- Release the auger control handle to stop the snow throwing action and the forward motion.

Stopping the Engine



WARNING: Muffler, engine and surrounding areas become hot and can cause a burn. Do not touch.

- After clearing snow, allow the engine to run for an extra few minutes before storing to help dry any moisture on the engine.
- To stop the engine: Turn the ignition key counterclockwise to the OFF position. Refer to **Ignition Key** on page 6. Remove the key from the snow thrower's ignition switch before storing.

SECTION 5: MAKING ADJUSTMENTS



WARNING: NEVER attempt to make any adjustments while the engine is running.

Control Cable & Belt Tension

As a result of both the control cable and the drive belt stretching due to wear, periodic adjustments may be necessary.

If the auger seems to hesitate when rotating while the engine maintains a constant speed, an adjustment is necessary. Proceed as follows:

The upper hole in the control handle provides for an adjustment in cable tension. To adjust, disconnect the end of control cable from the bottom hole in the control handle and reinsert it in the upper hole. Test the snow thrower to see if there is a noticeable difference.

Shave Plate

- To check the adjustment of the shave plate, place the unit on a level surface. The wheels, shave plate and augers should all contact the level surface. Note that if the shave plate is adjusted too high, snow may blow under the housing. If the shave plate wears out excessively, or the unit will not self-propel, the shave plate may be adjusted too low.

NOTE: On new units or units with a new shave plate installed, the augers may be slightly off the ground.

- To adjust, tip the snow thrower back so that it rests on the handle. Loosen the lock nuts from the carriage bolts which secure the shave plate to the housing. See Figure 4.
- Move the shave plate to desired position and retighten the nuts and bolts. Make certain all four nuts are securely tightened.

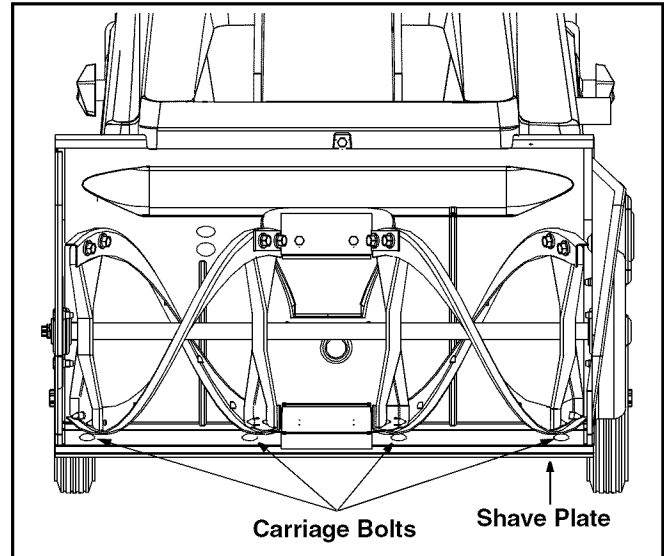

Figure 4

SECTION 6: MAINTAINING YOUR SNOW THROWER



WARNING: Before servicing, repairing, or inspecting, disengage the control handle and stop engine. Wait until all moving parts have come to a complete stop. Disconnect spark plug wire and ground it against the engine to prevent unintended starting.

Engine

Refer to the *Tecumseh* engine manual packed with the snow thrower for detailed instructions regarding all engine-related maintenance.

Lubrication

- Lubricate pivot points on the control handle and the extension spring at the end of the clutch cable with a light oil once every season and before storage of the snow thrower at the end of the season.

Hardware

Check the engine and snow thrower frequently for loose or missing hardware, and tighten or replace as necessary.

Replacing the Drive Belt

The snow thrower's drive belt is subject to wear and should be replaced if any signs of cracking, shredding or rotting is present. To change the drive belt, proceed as follows:

- Remove the belt cover from the left side of the snow thrower's auger housing by unthreading the five hex screws which secure it in place.
- Gently grasp the idler bracket and pivot it upward to ease tension on the drive belt. See Figure 5.
- While holding the idler bracket up, carefully slip the drive belt off the engine pulley. See Figure 5.

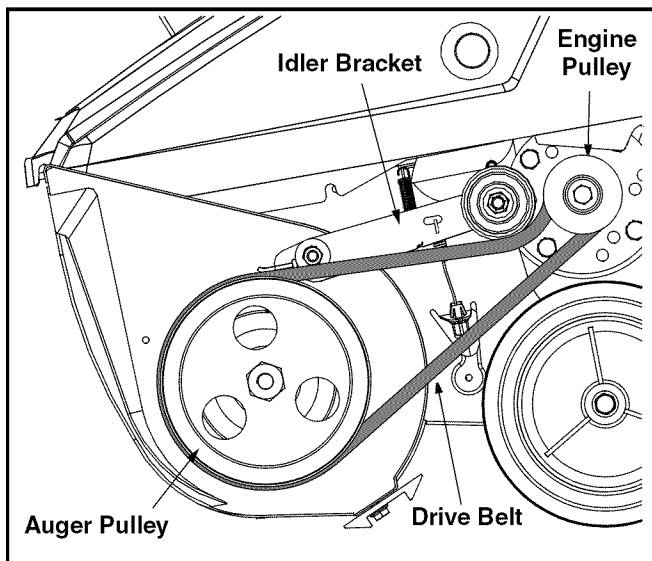

Figure 5

- Carefully release the idler bracket and allow it to pivot downward.
- Carefully slip the drive belt off the auger pulley, freeing it from the snow thrower. See Figure 5.
- Install the replacement drive belt by following the preceding steps in reverse order.
- Reattach the belt cover with the five hex screws removed earlier.

Replacing the Shave Plate

The shave plate is subject to wear and should be checked periodically. There are two wearing edges and the shave plate can be reversed after one side wears out.

To replace (or reverse) the shave plate, proceed as follows:

NOTE: Call 1-800-800-7310 for information regarding price and availability of Shave Plate Kit **753-0451** or contact an authorized MTD Service Dealer in your area.

- Remove the four carriage bolts and hex lock nuts which secure it to the snow thrower's auger housing. Refer to Figure 4.
- Install the new shave plate (or reverse the existing one, if both sides are not yet worn), making sure the heads of the carriage bolts are on the **inside** of the housing. The lock nuts should be on the **outside** of the housing.
- Adjust the shave plate as instructed in the **Making Adjustments** section on page 8 of this manual.
- Tighten the nuts securely before operating the snow thrower.

Replacing the Auger's Rubber Paddles

The snow thrower auger's rubber paddles are subject to wear and should be replaced if any signs of excessive wear is present.

NOTE: Call 1-800-800-7310 for information regarding the price and availability of Auger Kit **753-04472** or contact an authorized MTD Service Dealer in your area).

To change the rubber paddles, proceed as follows:

- Remove the existing rubber paddles by unthreading the self-tapping screws which secure them to the auger.
- Secure the replacement rubber paddles to the auger using the hardware removed earlier.

SECTION 7: OFF-SEASON STORAGE



WARNING: Never store engine with fuel in tank indoors or in enclosed, poorly ventilated areas where fuel fumes may reach an open flame, spark or pilot light as on a furnace, water heater, clothes dryer, or other gas appliance.

- Clean snow thrower thoroughly.
- Lubricate as instructed in the **Maintaining Your Snow Thrower** section on page 8 of this manual.
- Refer to the *Engines* manual packed with the snow thrower for detailed instructions regarding all engine-related storage instructions.

- Store the snow thrower in a clean, dry area.
- Place blocks under the front of the auger housing so that the snow thrower is not resting on the rubber auger paddles. The rubber can become misshaped if it supports the weight of the snow thrower for several months of storage.

NOTE: When storing any type of power equipment in a poorly ventilated or metal storage shed, care should be taken to rustproof the equipment, especially springs, cables and all moving parts.

SECTION 8: TROUBLESHOOTING GUIDE

Problem	Cause	Remedy
Engine fails to start	<ol style="list-style-type: none"> 1. Key not in ignition switch or not in ON position. 2. Fuel tank empty, or stale fuel 3. Blocked fuel line 4. Spark plug wire disconnected 5. Faulty spark plug 	<ol style="list-style-type: none"> 1. Insert key and turn to ON position 2. Fill tank with clean fresh gasoline/oil mixture as specified in the engine manual. 3. Clean fuel line 4. Connect wire to spark plug. 5. Clean spark plug, readjust gap, or replace.
Engine runs erratic	<ol style="list-style-type: none"> 1. Unit running with choke in ON position 2. Fuel line blocked, or stale fuel 3. Water or dirt in fuel system 4. Carburetor out of adjustment 	<ol style="list-style-type: none"> 1. Move choke lever to OFF position. 2. Clean fuel line and fill tank with fresh, clean gasoline/oil. 3. Refer to engine manual for remedy. 4. Refer to engine manual.
Loss of power	<ol style="list-style-type: none"> 1. Spark plug wire loose 2. Engine exhaust pipe plugged. 	<ol style="list-style-type: none"> 1. Connect and tighten spark plug wire. 2. Remove obstruction from exhaust pipe.
Excessive vibration	<ol style="list-style-type: none"> 1. Loose parts or damaged auger 	<ol style="list-style-type: none"> 1. Stop engine immediately and disconnect spark plug wire. Check for possible damage. Tighten all bolts and nuts. Repair as needed. If the problem persists, take unit to an authorized <i>MTD</i> service dealer.
Unit fails to self-propel	<ol style="list-style-type: none"> 1. Drive belt damaged 	<ol style="list-style-type: none"> 1. Inspect the drive belt for damage and replace if necessary as instructed on page 8 of this manual.
Unit fails to discharge snow	<ol style="list-style-type: none"> 1. Discharge chute clogged 2. Foreign object lodged in auger 3. Drive cable out of adjustment 4. Drive belt damaged 	<ol style="list-style-type: none"> 1. Stop engine immediately and disconnect spark plug wire. Clean discharge chute and the auger housing. 2. Stop engine immediately and disconnect spark plug wire. Remove object. 3. Adjust the control cable as instructed on page 8 of this manual. 4. Inspect the drive belt for damage and replace if necessary as instructed on page 8 of this manual.

SECTION 9: ACCESSORIES & KITS

The following accessories and kits are available for **single-stage, two-cycle snow throwers**. See the retailer from which you purchased your snow thrower, an authorized *MTD* Service Dealer or phone (800) 800-7310 for information regarding price and availability.

MODEL	DESCRIPTION
OEM-390-996	Electric Start Kit (fits models with a two-cycle Tecumseh 4.5 HP – 5 HP engine)
OEM-737-0325	<i>MTD</i> two-cycle snow thrower oil (contains six 2.6 oz. bottles)
753-0451	Shave Plate (includes replacement shave plate and hardware)
753-04472	Rubber Auger Kit, Snow Thrower Single Stage

SECTION 10: PARTS LIST

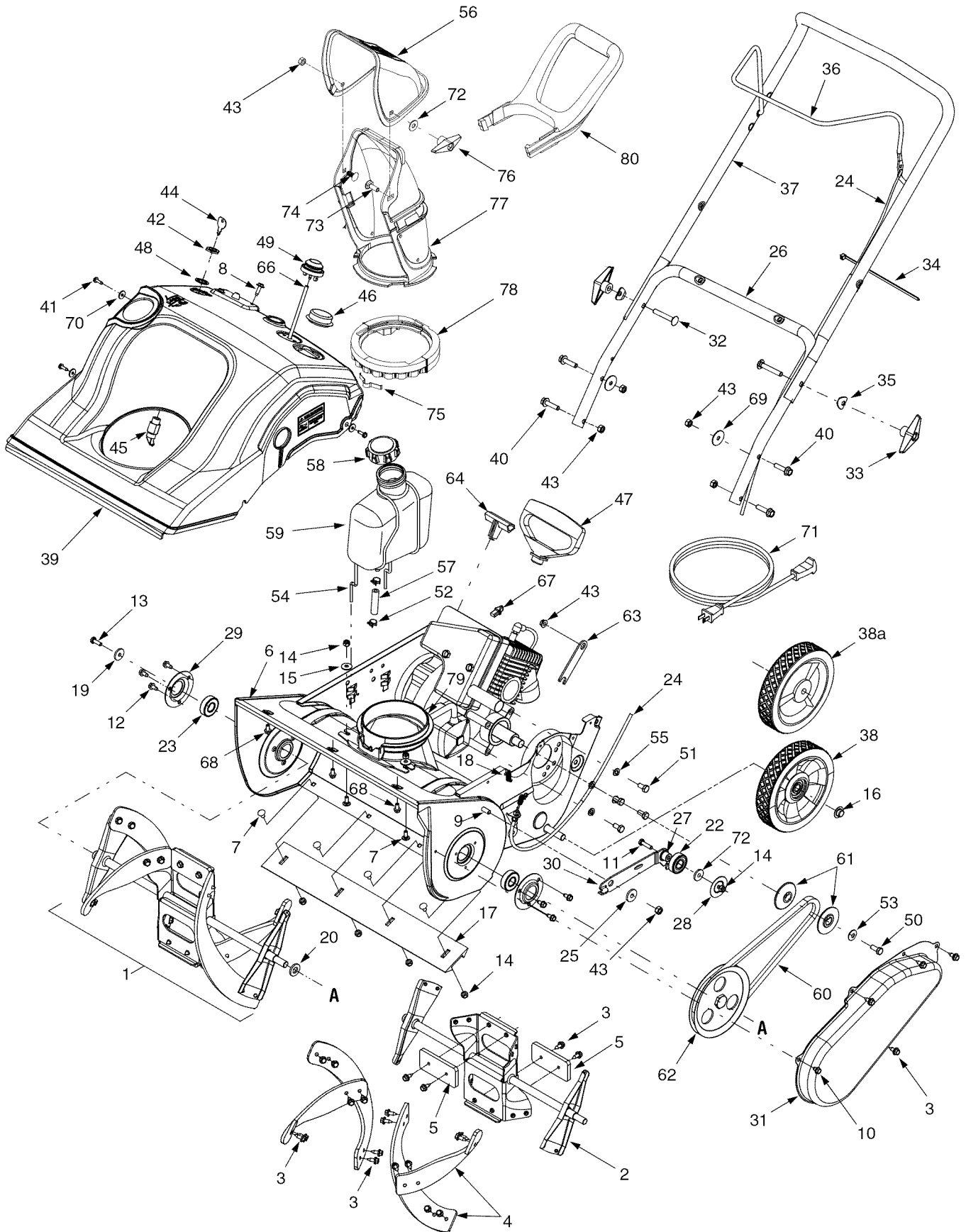

Models 262, S235 & S265

REF. NO.	PART NO.	DESCRIPTION	REF. NO.	PART NO.	DESCRIPTION
1	684-04027A	Auger Assembly Complete, 21"	41	710-1003	Hex Cap Screw, #10-16 x .625"
2	684-04025	Auger Weldment Assembly, 21"	42	712-0252	Hex Nut, 5/8-32 x .12
3	710-0896	Self-tapping Screw, 1/4-14 x 0.625"	43	712-04063	Hex Flange Lock Nut, 5/16-18, Gr. 5
4	735-04032	Rubber Spiral	44	725-0201	Key
5	735-04033	Rubber Paddle	45	725-2018	Key Switch
6	684-04126	Auger Housing Assembly 21"	46	731-1133C	Plastic Cap, 1.75 Dia x .72
7	710-0134	Carriage Bolt, 1/4-20 x .62"	47	7510009636	Recoil Handle (Mitten Grip)
8	710-1003	Screw, #10-16 x .625	48	736-0225	Lock Washer Internal, .625 x 1.058
9	710-3008	Screw, 5/16-18 x .75	49	7512B1476	Primer Button
10	710-0653	Self-tapping Screw, 1/4-20 x .375	50	710-0627	Hex Screw, 5/16-24 x .75 Gr. 75
11	710-0597	Hex Screw, 1/4-20 x 1.00 Gr. 5	51	710-3025	Hex Screw, 5/16-18 x .625 Gr. 5
12	710-1005	Hex Cap Screw, 1/4-14 x .50"	52	726-0205	Hose Clamp
13	710-0433	Hex Cap Screw, 1/4-20 x .625"	53	736-0242	Cupped Washer, .340 x .872 x .060
14	712-04064	Hex Flange Lock Nut, 1/4-20	54	747-04150	Gas Tank Wire Support
15	736-0176	Flat Washer, .265 x .938 x .120	55	736-0119	Lock Washer, 5/16
16	726-0299	Push Cap, 1/2"	56	731-04426A	Upper Chute
17	731-1033	Shave Plate, 2.66 x 19.88	57	751-0535-17	Fuel Line
18	732-0357A	Extension Spring, .33 OD x 1.12	58	751-10049	Fuel Cap
19	736-0176	Flat Washer, .265 x .938 x .120	59	751-10023	Fuel Tank, 2 Quart
20	736-0326	Flat Washer, .510 x 1.00 x .125	60	754-0101A	V-Belt, 1/2
22	741-0919	Ball Bearing	61	756-0416B	Pulley Half, .625 ID x 2.25 OD
23	741-0600	Ball Bearing, 17 x 40 x 12	62	756-0475	Pulley, 1/2 x 1/2-20 x 6.0
24	746-04091	Clutch Cable	63	790-00048	Mounting Bracket Support
25	748-0234	Shoulder Spacer	64	7519630	Recoil Handle
26	749-04114	Lower Handle	65	712-3004A	Hex Flange Lock Nut 5/16-18 Gr. 5
27	750-04230	Flange Spacer	66	723-0345	Primer Tube
28	790-00062	Belt Keeper	67	7511825510	Choke Lever Knob
29	784-5174	Bearing Cup	68	710-04187	Hex Screw, 1/4-15 x .50
30	790-00039	Idler Bracket w/ Brake	69	736-0362	Flat Washer, .320 x 1.25
31	790-00045	Belt Cover	70	736-0400	Flat Washer, .194 x .62 x .063
32	710-0487	Carriage Bolt, 5/16-18 x 2.0	71	629-0236	Extension Cord, 2-Prong
33	720-0284	Handle Knob Assembly, 5/16-18	72	736-0159	Flat Washer, .349 x .879 x .063
34	725-0157	Cable Tie	73	710-04071	Carriage Screw, 5/16-18 x 1.0
35	736-0451	Saddle Washer, .320 ID x .93	74	710-0451	Carriage Bolt, 5/16-18 x .075
36	747-04159	Bail, Gullwing	75	732-04111	Chute Adjustment Spring
37	749-04106	Upper Handle, Gullwing	76	720-0284	Handle Knob Assembly, 5/16-18
38	734-04063	Wheel-Star, 7 x 1.5	77	731-04127	Lower Chute 5" Dia
38a	734-04070	Wheel-3 spoke, 7 x 1.61	78	731-04353	Lower Chute Ring
39	684-04044	Shroud Assembly	79	731-04886	Chute Adapter, 5" Dia
40	710-1882	Hex Flange Screw 5/16-18 x 1.50 Gr. 5	80	731-04388A	Chute Handle

IMPORTANT: For a proper working machine, use Factory Approved Parts. **V-belts** are designed to engage and disengage safely. A substitute (non OEM) V-belt can be dangerous by not disengaging completely.

NOTE: Snow thrower features/components vary by model. NOT all parts listed above and pictured on the previous page are standard equipment.

NOTES

NOTES

MANUFACTURER'S LIMITED WARRANTY FOR:



The limited warranty set forth below is given by MTD LLC with respect to new merchandise purchased and used in the United States, its possessions and territories.

“MTD” warrants this product against defects in material and workmanship for a period of two (2) years commencing on the date of original purchase and will, at its option, repair or replace, free of charge, any part found to be defective in materials or workmanship. This limited warranty shall only apply if this product has been operated and maintained in accordance with the Operator’s Manual furnished with the product, and has not been subject to misuse, abuse, commercial use, neglect, accident, improper maintenance, alteration, vandalism, theft, fire, water, or damage because of other peril or natural disaster. Damage resulting from the installation or use of any part, accessory or attachment not approved by MTD for use with the product(s) covered by this manual will void your warranty as to any resulting damage.

Normal wear parts are warranted to be free from defects in material and workmanship for a period of thirty (30) days from the date of purchase. Normal wear parts include, but are not limited to items such as: batteries, belts, blades, blade adapters, grass bags, rider deck wheels, seats, snow thrower skid shoes, shave plates, auger spiral rubber and tires.

HOW TO OBTAIN SERVICE: Warranty service is available, WITH PROOF OF PURCHASE, through your local authorized service dealer. To locate the dealer in your area, check your Yellow Pages, or contact MTD LLC at P.O. Box 361131, Cleveland, Ohio 44136-0019, or call 1-800-800-7310 or 1-330-220-4683 or log on to our Web site at www.mtdproducts.com.

This limited warranty does **not** provide coverage in the following cases:

- a. The engine or component parts thereof. These items may carry a separate manufacturer’s warranty. Refer to applicable manufacturer’s warranty for terms and conditions.
- b. Log splitter pumps, valves, and cylinders have a separate one year warranty.
- c. Routine maintenance items such as lubricants, filters, blade sharpening, tune-ups, brake adjustments, clutch adjustments, deck adjustments, and normal deterioration of the exterior finish due to use or exposure.
- d. Service completed by someone other than an authorized service dealer.

- e. MTD does not extend any warranty for products sold or exported outside of the United States, its possessions and territories, except those sold through MTD’s authorized channels of export distribution.
- f. Replacement parts that are not genuine MTD parts.
- g. Transportation charges and service calls.

No implied warranty, including any implied warranty of merchantability of fitness for a particular purpose, applies after the applicable period of express written warranty above as to the parts as identified. No other express warranty, whether written or oral, except as mentioned above, given by any person or entity, including a dealer or retailer, with respect to any product, shall bind MTD. During the period of the warranty, the exclusive remedy is repair or replacement of the product as set forth above.

The provisions as set forth in this warranty provide the sole and exclusive remedy arising from the sale. MTD shall not be liable for incidental or consequential loss or damage including, without limitation, expenses incurred for substitute or replacement lawn care services or for rental expenses to temporarily replace a warranted product.

Some states do not allow the exclusion or limitation of incidental or consequential damages, or limitations on how long an implied warranty lasts, so the above exclusions or limitations may not apply to you.

In no event shall recovery of any kind be greater than the amount of the purchase price of the product sold. **Alteration of safety features of the product shall void this warranty.** You assume the risk and liability for loss, damage, or injury to you and your property and/or to others and their property arising out of the misuse or inability to use the product.

This limited warranty shall not extend to anyone other than the original purchaser or to the person for whom it was purchased as a gift.

HOW STATE LAW RELATES TO THIS WARRANTY: This limited warranty gives you specific legal rights, and you may also have other rights which vary from state to state.

IMPORTANT: Owner must present Original Proof of Purchase to obtain warranty coverage.

MTD LLC, P.O. BOX 361131 CLEVELAND, OHIO 44136-0019; Phone: 1-800-800-7310, 1-330-220-4683