

# OPERATOR'S MANUAL

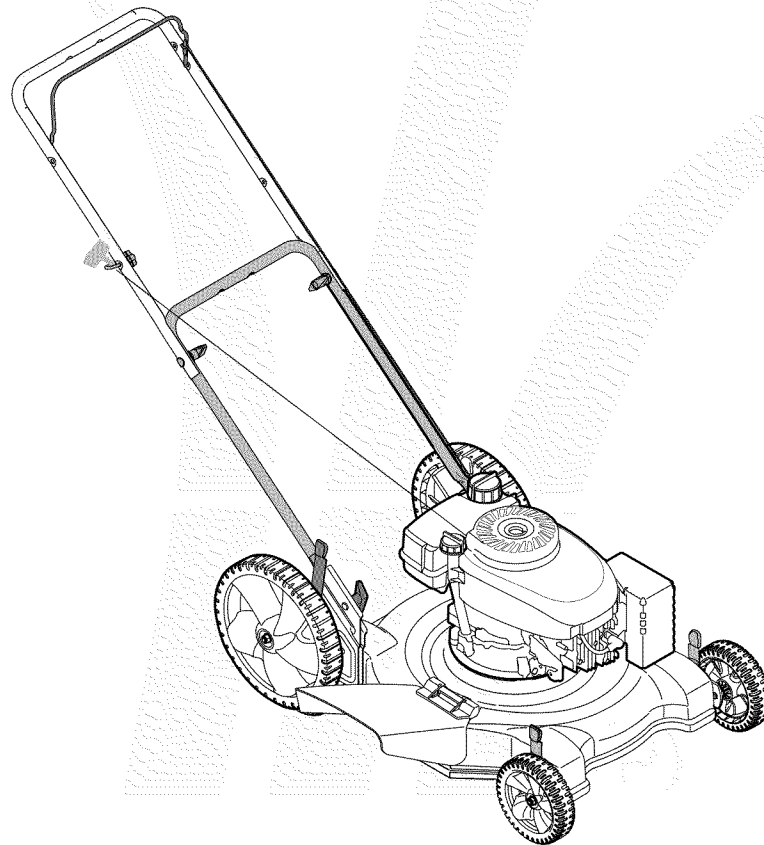

## 22" Rotary Mower — Model Series 500

### IMPORTANT

#### READ SAFETY RULES AND INSTRUCTIONS CAREFULLY BEFORE OPERATION

**Warning:** This unit is equipped with an internal combustion engine and should not be used on or near any unimproved forest-covered, brush-covered or grass-covered land unless the engine's exhaust system is equipped with a spark arrester meeting applicable local or state laws (if any). If a spark arrester is used, it should be maintained in effective working order by the operator. In the State of California the above is required by law (Section 4442 of the California Public Resources Code). Other states may have similar laws. Federal laws apply on federal lands. A spark arrester for the muffler is available through your nearest engine authorized service dealer or contact the service department, P.O. Box 361131 Cleveland, Ohio 44136-0019.

This Operator's Manual is an important part of your new equipment. It will help you assemble, prepare and maintain the unit for best performance. Please read and understand what it says.

## Table of Contents

Slope Gauge .....	3	Maintenance & Off-Season Storage.....	10
Safe Operation Practices .....	4	Trouble Shooting .....	12
Set-Up & Adjustments.....	6	Warranty .....	13
Operation.....	8	Illustrated Parts Lists .....	14

## Finding and Recording Model Number

### BEFORE YOU START ASSEMBLING YOUR NEW EQUIPMENT,

please locate the model plate on the equipment and copy the the model number and the serial number to the sample model plate provided to the right. You can locate the model plate by standing at the operating position and looking down at the rear of the machine.

Model Number Numéro de modèle	Serial Number Numéro de série
XXXXXXXXXX	XXXXXXXXXX
	MTD LLC CLEVELAND, OH 44136 MTD PRODUCTS LIMITED KITCHENER, ON N2G 4J1
USA-www.mtdproducts.com	1-800-800-7310
CAN-www.mtdcanada.com	1-800-668-1238

## Customer Support

**Please do *NOT* return the unit to the retailer from which it was purchased,  
without first contacting Customer Support.**

If you have difficulty assembling this product or have any questions regarding the controls, operation or maintenance of this unit, please call a Customer Support Representative.

**For US Customers: 1-330-220-4MTD (4683) or 1-800-800-7310**

**For Canadian Customers: 1-800-668-1238**

Please have your unit's model number and serial number ready when you call. See previous section to locate this information. You will be asked to enter the serial number in order to process your call.

The engine manufacturer is responsible for all engine-related issues with regards to performance, power-rating, specifications, warranty and service. Please refer to the engine manufacturer's Owner's/Operator's Manual, packed separately with your unit, for more information.

# 1

## Slope Gauge

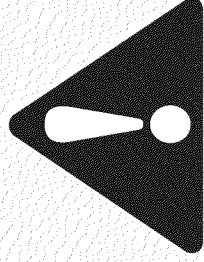

### WARNING

Do not mow on inclines with a slope in excess of 15 degrees (a rise of approximately 2-1/2 feet every 10 feet). A riding mower could overturn and cause serious injury. If operating a walk-behind mower on such a slope, it is extremely difficult to maintain your footing and you could slip, resulting in serious injury.

**Operate RIDING mowers up and down slopes, never across the face of slopes.**

**Operate WALK-BEHIND mowers across the face of slopes, never up and down slopes.**

Use this page as a guide to determine slopes where you may not operate safely. **Do not operate** your lawn mower on such slopes.

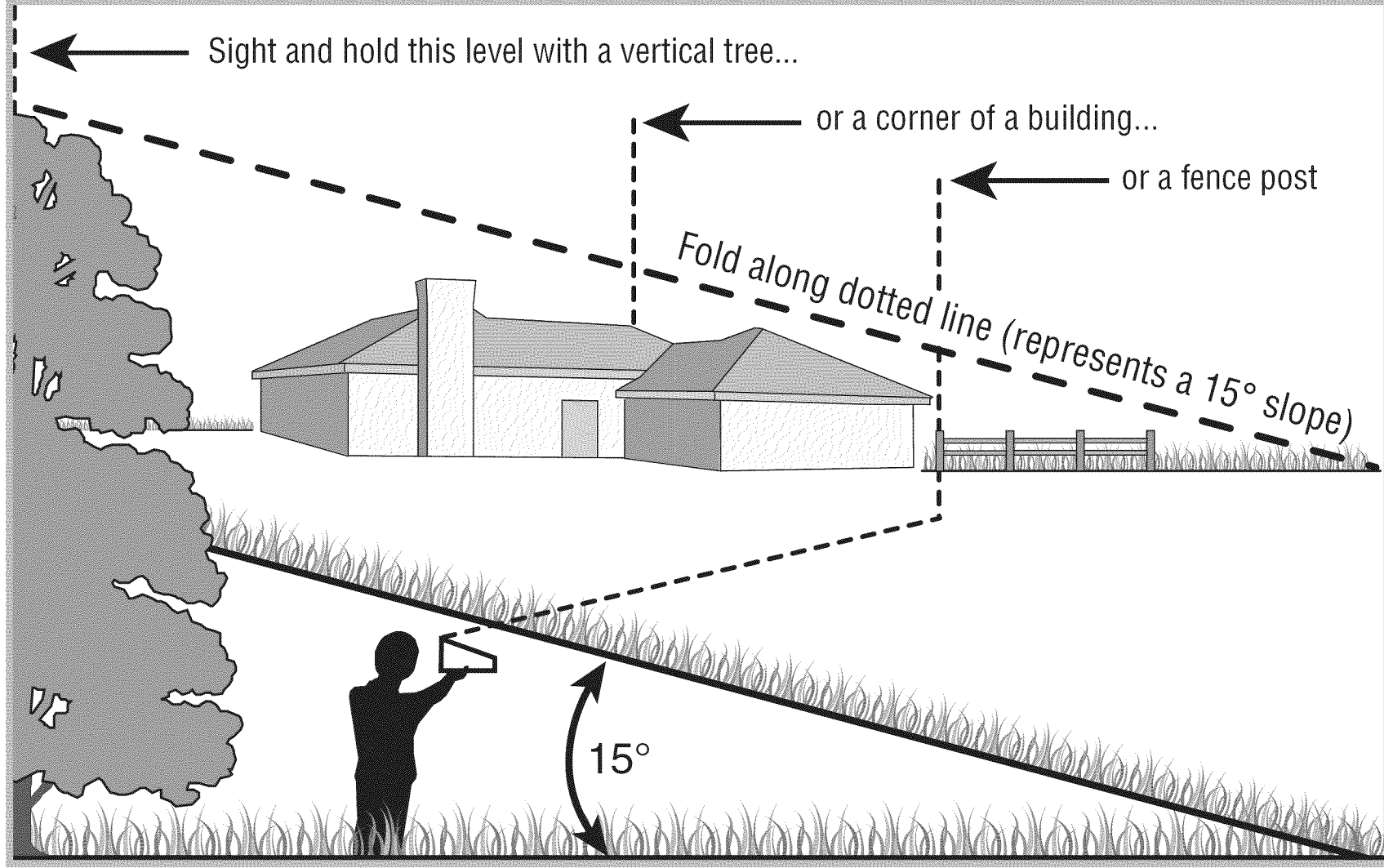

# 2

## Safe Operation Practices



### WARNING

This symbol points out important safety instructions which, if not followed, could endanger the personal safety and/or property of yourself and others. Read and follow all instructions in this manual before attempting to operate this machine. Failure to comply with these instructions may result in personal injury. When you see this symbol. **HEED ITS WARNING!**

**Your Responsibility**  
Restrict the use of this power machine to persons who read, understand and follow the warnings and instructions in this manual and on the machine.



**WARNING:** Engine Exhaust, some of its constituents, and certain vehicle components contain or emit chemicals known to State of California to cause cancer and birth defects or other reproductive harm.

**DANGER:** This machine was built to be operated according to the rules for safe operation in this manual. As with any type of power equipment, carelessness or error on the part of the operator can result in serious injury. This machine is capable of amputating hands and feet and throwing objects. Failure to observe the following safety instructions could result in serious injury or death.

### General Operation

1. Read this operator's manual carefully in its entirety before attempting to assemble this machine. Read, understand, and follow all instructions on the machine and in the manual(s) before operation. Be completely familiar with the controls and the proper use of this machine before operating it. Keep this manual in a safe place for future and regular reference and for ordering replacement parts.
2. This machine is a precision piece of power equipment, not a plaything. Therefore, exercise extreme caution at all times. Your unit has been designed to perform one job: to mow grass. Do not use it for any other purpose.
3. Never allow children under 14 years old to operate this machine. Children 14 years old and over should read and understand the instructions in this manual and should be trained and supervised by a parent. Only responsible individuals who are familiar with these rules of safe operation should be allowed to use this machine.
4. Thoroughly inspect the area where the equipment is to be used. Remove all stones, sticks, wire, bones, toys and other foreign objects which could be tripped over or picked up and thrown by the blade. Thrown objects can cause serious personal injury. Plan your mowing pattern to avoid discharge of material toward roads, sidewalks, bystanders and the like. Also, avoid discharging material against a wall or obstruction which may cause discharged material to ricochet back toward the operator.
5. To help avoid blade contact or a thrown object injury, stay in the operator zone behind the handles and keep children, bystanders, helpers and pets at least 75 feet from the mower while it is in operation. Stop machine if anyone enters the area.
6. Always wear safety glasses or safety goggles during operation and while performing an adjustment or repair to protect your eyes. Thrown objects which ricochet can cause serious injury to the eyes.
7. Wear sturdy, rough-soled work shoes and close-fitting slacks and shirts. Shirts and pants that cover the arms and legs and steel-toed shoes are recommended. Never operate this machine in bare feet, sandals, slippery or light weight (e.g. canvas) shoes.
8. Do not put hands or feet near rotating parts or under the cutting deck. Contact with the blade can amputate hands and feet.
9. A missing or damaged discharge cover can cause blade contact or thrown object injuries.
10. Many injuries occur as a result of the mower being pulled over the foot during a fall caused by slipping or tripping. Do not hold on to the mower if you are falling; release the handle immediately.
11. Never pull the mower back toward you while you are walking. If you must back the mower away from a wall or obstruction first look down and behind to avoid tripping and then follow these steps:
  - a. Step back from the mower to fully extend your arms.
  - b. Be sure you are well balanced with sure footing.
  - c. Pull the mower back slowly, no more than half way toward you.
  - d. Repeat these steps as needed.
12. Do not operate the mower while under the influence of alcohol or drugs.
13. Do not engage the self-propelled mechanism on units so equipped while starting engine.
14. The blade control handle is a safety device. Never attempt to bypass its operation. Doing so makes the safety device inoperative and may result in personal injury through contact with the rotating blade. The blade control handle must operate easily in both directions and automatically return to the disengaged position when released.
15. Never operate the mower in wet grass. Always be sure of your footing. A slip and fall can cause serious personal injury. If you feel you are losing your footing, release the blade control handle immediately and the blade will stop rotating within three seconds.
16. Mow only in daylight or in good artificial light. Walk, never run. Stop the blade when crossing gravel drives, walks or roads.
17. If the equipment should start to vibrate abnormally, stop the engine and check immediately for the cause. Vibration is generally a warning of trouble.
18. Shut the engine off and wait until the blade comes to a complete stop before removing the grass catcher or unclogging the chute. The cutting blade continues to rotate for a few seconds after the engine is shut off. Never place any part of the body in the blade area until you are sure the blade has stopped rotating.
19. Never operate mower without proper trail shield, discharge cover, grass catcher, blade control handle or other safety protective devices in place and working. Never operate mower with damaged safety devices. Failure to do so, can result in personal injury.
20. Muffler and engine become hot and can cause a burn. Do not touch.
21. Only use parts and accessories made for this machine by the manufacturer. Failure to do so can result in personal injury.
22. If situations occur which are not covered in this manual, use care and good judgment. Call customer assistance for the name of your nearest servicing dealer.

### Slope Operation

Slopes are a major factor related to slip and fall accidents which can result in severe injury. Operation on slopes requires extra caution. If you feel uneasy on a slope, do not mow it. For your safety, use the slope gauge included as part of this manual to measure slopes before operating this unit on a sloped or hilly area. If the slope is greater than 15 degrees, do not mow it.

## Do:

1. Mow across the face of slopes; never up and down. Exercise extreme caution when changing direction on slopes.
2. Watch for holes, ruts, rocks, hidden objects, or bumps which can cause you to slip or trip. Tall grass can hide obstacles.
3. Always be sure of your footing. A slip and fall can cause serious personal injury. If you feel you are losing your balance, release the blade control handle immediately, and the blade will stop rotating within 3 seconds.

## Do Not:

1. Do not mow near drop-offs, ditches or embankments, you could lose your footing or balance.
2. Do not mow slopes greater than 15 degrees as shown on the slope gauge.
3. Do not mow on wet grass. Unstable footing could cause slipping.

## Children

Tragic accidents can occur if the operator is not alert to the presence of children. Children are often attracted to the mower and the mowing activity. They do not understand the dangers. Never assume that children will remain where you last saw them.

1. Keep children out of the mowing area and under the watchful care of a responsible adult other than the operator.
2. Be alert and turn mower off if a child enters the area.
3. Before and while moving backwards, look behind and down for small children.
4. Use extreme care when approaching blind corners, doorways, shrubs, trees, or other objects that may obscure your vision of a child who may run into the mower.
5. Keep children away from hot or running engines. They can suffer burns from a hot muffler.
6. Never allow children under 14 years old to operate a power mower. Children 14 years old and over should read and understand the operation instructions and safety rules in this manual and should be trained and supervised by a parent.

## Service

### Safe Handling Of Gasoline:

1. To avoid personal injury or property damage use extreme care in handling gasoline. Gasoline is extremely flammable and the vapors are explosive. Serious personal injury can occur when gasoline is spilled on yourself or your clothes which can ignite.
2. Wash your skin and change clothes immediately.
3. Use only an approved gasoline container.
4. Never fill containers inside a vehicle or on a truck or trailer bed with a plastic liner. Always place containers on the ground away from your vehicle before filling.
5. Remove gas-powered equipment from the truck or trailer and refuel it on the ground. If this is not possible, then refuel such equipment on a trailer with a portable container, rather than from a gasoline dispenser nozzle.
6. Keep the nozzle in contact with the rim of the fuel tank or container opening at all times until fueling is complete. Do not use a nozzle lock-open device.
7. Extinguish all cigarettes, cigars, pipes and other sources of ignition.

8. Never fuel machine indoors because flammable vapors will accumulate in the area.
9. Never remove gas cap or add fuel while the engine is hot or running. Allow engine to cool at least two minutes before refueling.
10. Never over fill fuel tank. Fill tank to no more than ½ inch below bottom of filler neck to provide for fuel expansion.
11. Replace gasoline cap and tighten securely.
12. If gasoline is spilled, wipe it off the engine and equipment. Move unit to another area. Wait 5 minutes before starting the engine.
13. Never store the machine or fuel container near an open flame, spark or pilot light as on a water heater, space heater, furnace, clothes dryer or other gas appliances.
14. To reduce fire hazard, keep mower free of grass, leaves, or other debris build-up. Clean up oil or fuel spillage and remove any fuel soaked debris.
15. Allow a mower to cool at least 5 minutes before storing.

### General Service:

1. Never run an engine indoors or in a poorly ventilated area. Engine exhaust contains carbon monoxide, an odorless and deadly gas.
2. Before cleaning, repairing, or inspecting, make certain the blade and all moving parts have stopped. Disconnect the spark plug wire and ground against the engine to prevent unintended starting.
3. Check the blade and engine mounting bolts at frequent intervals for proper tightness. Also, visually inspect blade for damage (e.g., bent, cracked, worn) Replace blade with the original equipment manufacturer's (O.E.M.) blade only, listed in this manual. "Use of parts which do not meet the original equipment specifications may lead to improper performance and compromise safety!"
4. Mower blades are sharp and can cut. Wrap the blade or wear gloves, and use extra caution when servicing them.
5. Keep all nuts, bolts, and screws tight to be sure the equipment is in safe working condition.
6. Never tamper with safety devices. Check their proper operation regularly.
7. After striking a foreign object, stop the engine, disconnect the spark plug wire and ground against the engine. Thoroughly inspect the mower for any damage. Repair the damage before starting and operating the mower.
8. Never attempt to make a wheel or cutting height adjustment while the engine is running.
9. Grass catcher components, discharge cover, and trail shield are subject to wear and damage which could expose moving parts or allow objects to be thrown. For safety protection, frequently check components and replace immediately with original equipment manufacturer's (O.E.M.) parts only, listed in this manual. "Use of parts which do not meet the original equipment specifications may lead to improper performance and compromise safety!"
10. Do not change the engine governor setting or overspeed the engine. The governor controls the maximum safe operating speed of the engine.
11. Maintain or replace safety labels, as necessary.
12. Observe proper disposal laws and regulations. Improper disposal of fluids and materials can harm the environment.

# 2

## Safe Operation Practices



### WARNING

This symbol points out important safety instructions which, if not followed, could endanger the personal safety and/or property of yourself and others. Read and follow all instructions in this manual before attempting to operate this machine. Failure to comply with these instructions may result in personal injury. When you see this symbol. **HEED ITS WARNING!**

### Your Responsibility

Restrict the use of this power machine to persons who read, understand and follow the warnings and instructions in this manual and on the machine.

# 3

## Setup and Adjustments

Tools Required for Assembly:  
• 9/16-inch wrench



Your mower is shipped with the handle in the higher height position.

NOTE: Each end of the lower handle must be placed in the same relative position.



### WARNING

**IMPORTANT**  
This unit is shipped **WITHOUT GASOLINE or OIL**. After assembly, service engine with gasoline and oil as instructed in the separate engine manual packed with your unit.

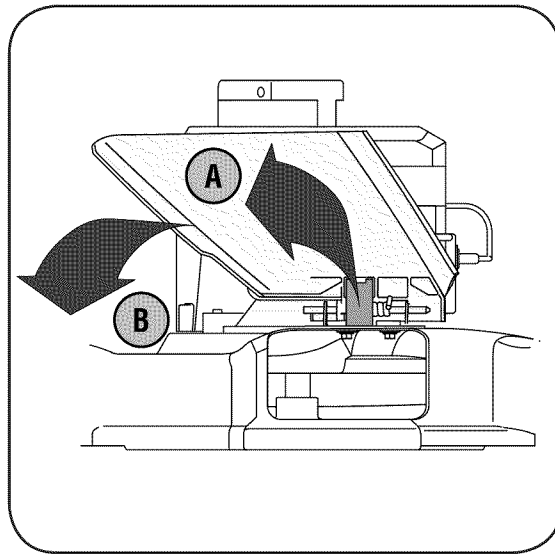

Figure 1

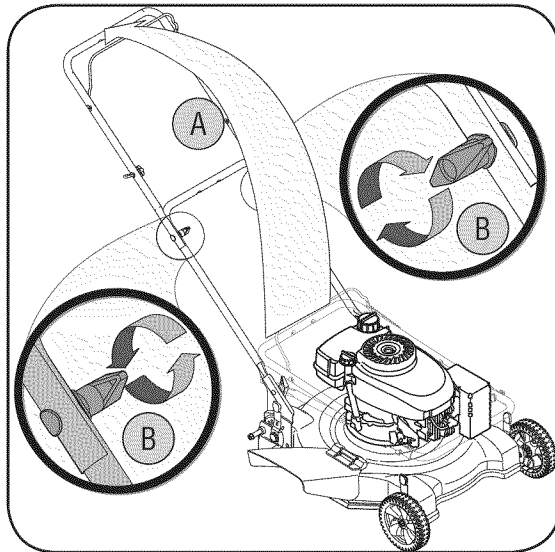

Figure 2

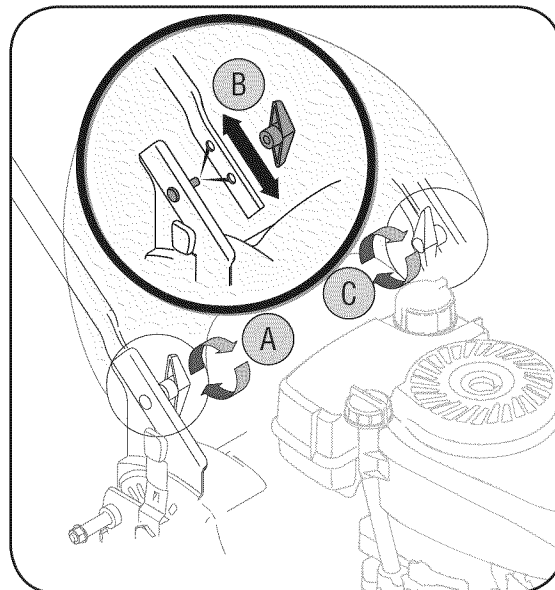

Figure 3



**WARNING: Disconnect and ground the spark plug wire as instructed in the separate engine manual.**

1. The chute deflector on your mower may be held in an upright position by a block for shipping purposes only. This shipping block must be removed and discarded before the mower is put into operation. See Figure 1.
  - a. Pull the chute deflector up towards engine.
  - b. Remove the block and carefully lower the chute into operating position, keeping fingers out of the way.
2. Perform the following sequence for handle setup:
  - a. Pull up and back on the upper handle to raise the handle from position A into the operating position B. See Figure 2.
  - b. Make sure the carriage bolt is seated properly in the handle. Tighten wing nuts (star knobs) securing upper handle to the lower handle.

**NOTE:** On some models wing nuts have been replaced with star knobs. Figures show wing nuts only.

3. If satisfied with height of handle, tighten wing nuts (star knobs) at the ends of the lower handle shown in Figure 3. For convenience of operating, you may adjust the handle height as follows:
  - a. Remove the wing nuts (star knobs) shown in Figure 3 and remove the lower handle.
  - b. Position each handle bracket stud into the top hole in the lower handle. See Figure 3 inset.
  - c. Tighten the wing nuts (star knobs).
4. Insert post on cable ties into holes provided on the lower handle. Pull cable tie tight and trim excess. See Figure 4.

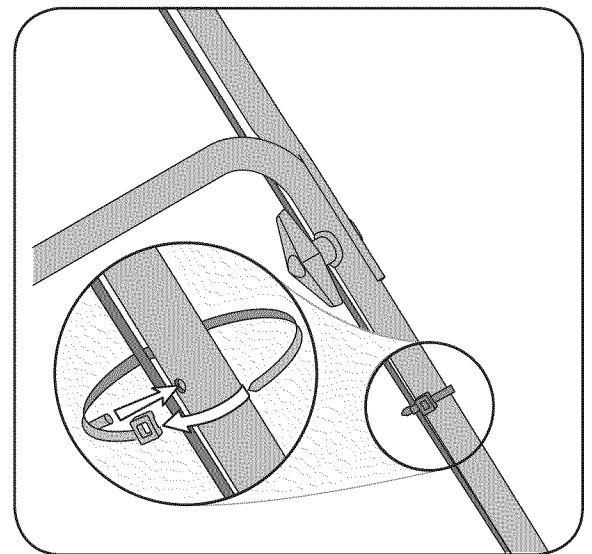

Figure 4

5. Rope guide Setup as follows, see Figure 5:

- a. Hold the blade control against the upper handle. Position A.
- b. Slowly pull starter rope out of engine. Position B.
- c. Slip starter rope into the rope guide. Tighten rope guide wing nut. Position C.

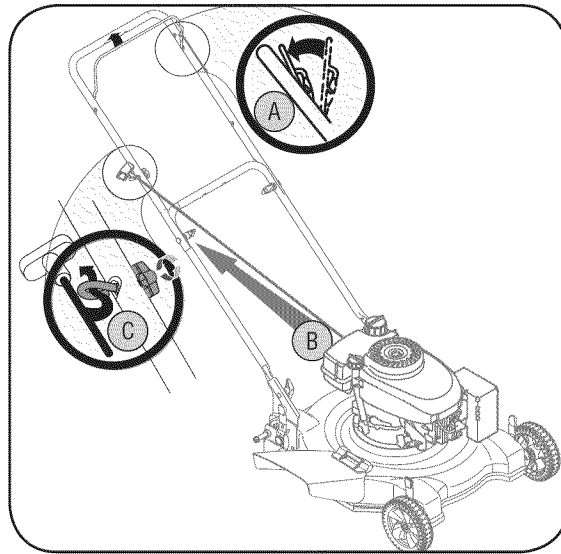

Figure 5

6. Installing the rear wheels.

- a. Place the rear of the mower deck on raised blocks.
- b. Remove the lock nut from the pivot arm assembly (on select models, these may be included separately in a plastic bag), slide wheel, with hollow side in, onto pivot arm and secure with lock nut. See Figure 6.
- c. Assemble the other side in the same manner.

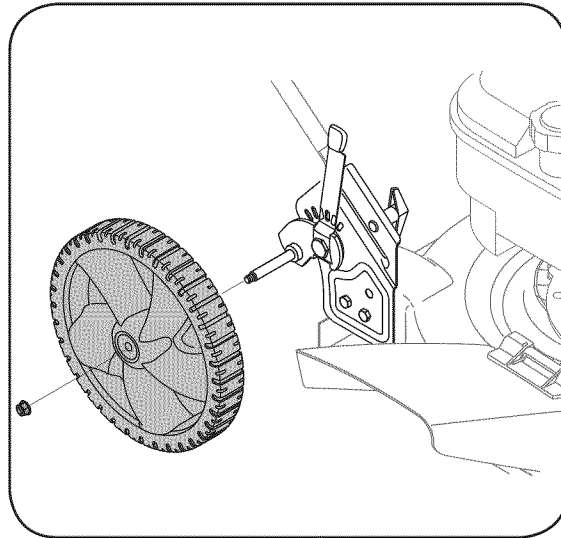

Figure 6

7. Each wheel has a height adjustment lever to change the cutting height of the mower. To change the height of cut, squeeze adjuster lever toward the wheel, moving up or down to selected height. See Figure 7.

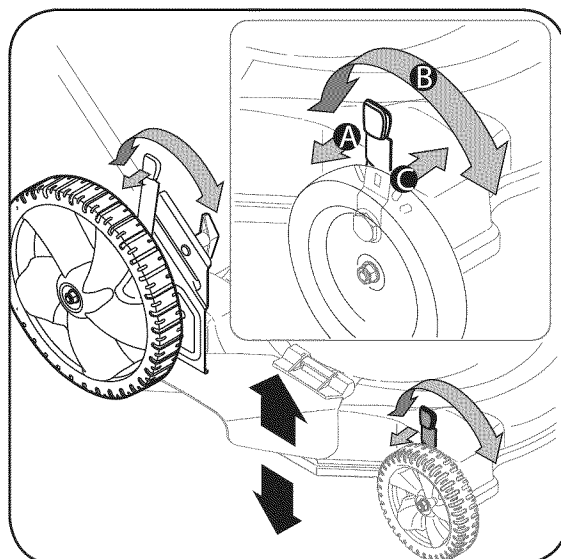

Figure 7

8. If your mower is equipped with an optional mulching baffle, install it as shown in Figure 8.

- a. Lift up and hold the side-discharge chute deflector and insert bottom lip of the mulching baffle inside the chute opening.
- b. Push the hooks on the top of the baffle until they snap over the hinge on the discharge chute. Release the chute deflector.

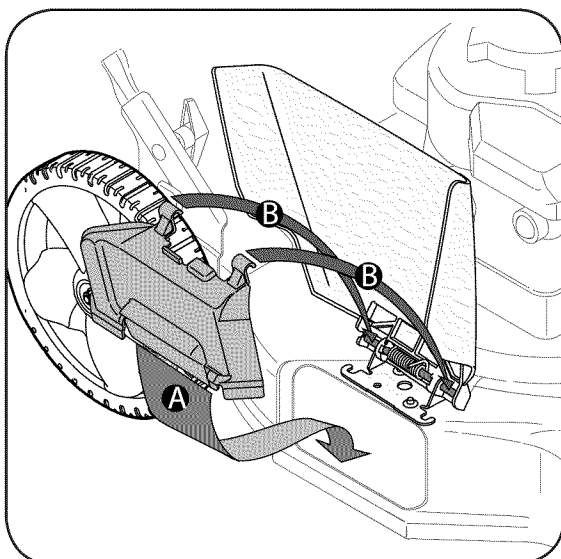

Figure 8

# 3

## Setup and Adjustments



On select models, the front wheels may also need to be installed. Install these in the same manner as the rear wheels.

**NOTE:** All wheels must be placed in the same relative position. For rough or uneven lawns, move the height adjustment lever to a higher position. This will stop scalping of grass.

**NOTE:** When you wish to mow instead of mulch, simply raise the chute deflector, grasp the handle on the mulching baffle and lift upward to remove the baffle. It is not necessary to remove the mulching blade.

# 4

## Operating Your Lawn Mower



### WARNING

Read, understand, and follow all instructions and warnings on the machine and in this manual before operating.

This blade control mechanism is a safety device. Never attempt to bypass its operations.

Use extreme care when handling gasoline. Gasoline is extremely flammable and the vapors are explosive. *Never fuel the machine indoors or while the engine is hot or running.* Extinguish cigarettes, cigars, pipes and other sources of ignition.

## Know Your Lawn Mower

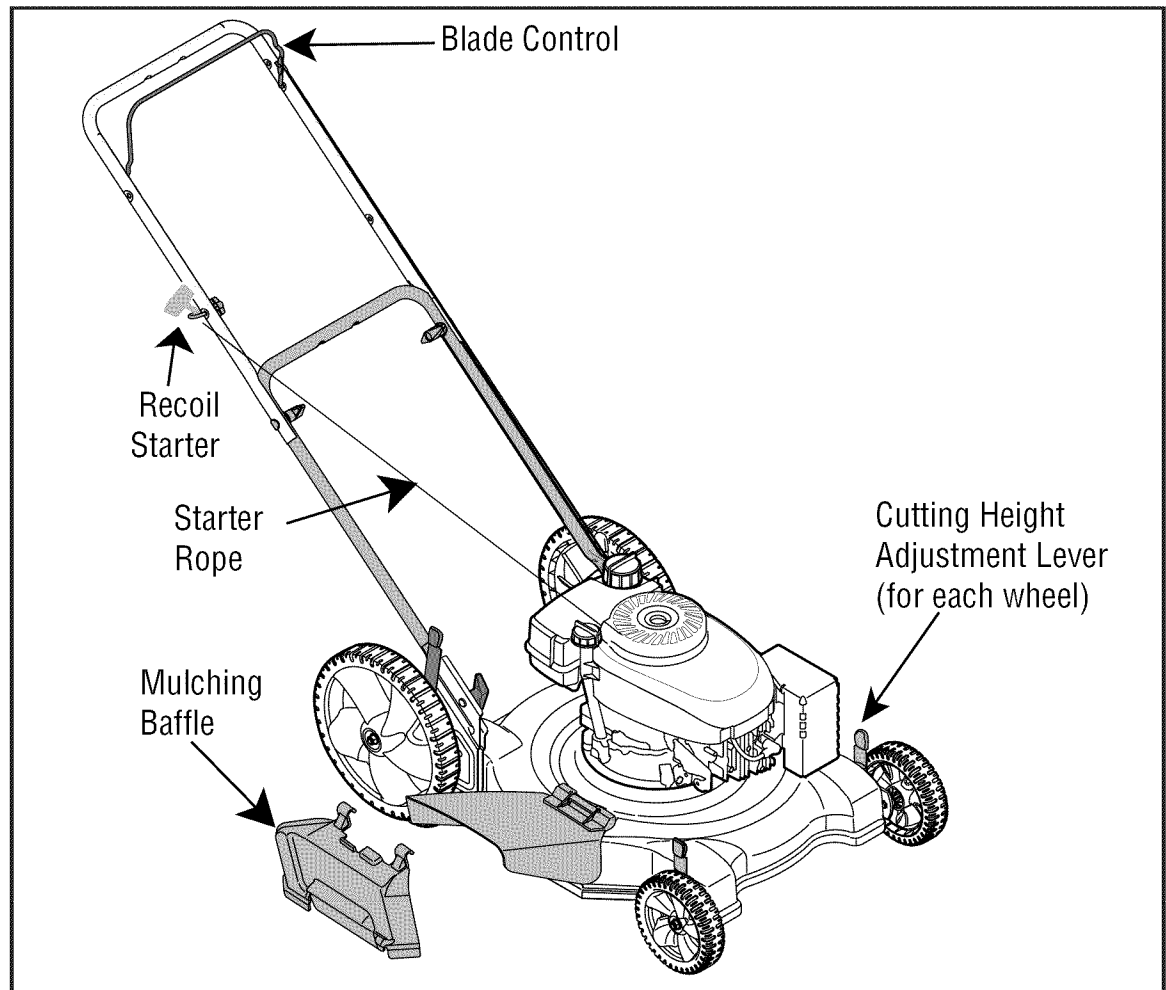

Figure 9

### Blade Control Handle

The blade control handle is located on the upper handle of the mower. See Figure 9. The blade control handle must be depressed in order to operate the unit. Release the blade control handle to stop the engine and blade.

### Recoil Starter

The recoil starter is attached to the right upper handle. Stand behind the unit and pull the recoil starter rope to start the unit.

### Mulching Baffle (If so equipped)

The mulching baffle is used to recirculate grass clippings back to the lawn. Attach it as instructed on page 7 of this manual.

### Cutting Height Adjustment Levers (If so equipped)

One adjustment lever is located on each wheel and is used to adjust the cutting height. All four levers have to be at the same relative position to ensure uniform cut.

### Before Starting

1. Service the engine with gasoline and oil as instructed in the separate engine manual.
2. Attach spark plug wire to spark plug. If unit is equipped with a rubber boot over the end of the spark plug wire, make certain the metal loop on the end of the spark plug wire (inside the rubber boot) is fastened securely over the metal tip on the spark plug.

### To Start Engine

1. If your unit is equipped with a primer, prime engine as instructed in the separate engine manual packed with your unit.
2. Standing behind the unit, depress the blade control handle and hold it against the upper handle as shown in Figure 10.
3. Grasp the starter handle as shown and pull slowly until resistance is felt, then pull rapidly to start engine and avoid kickback. Return it slowly to the rope guide.



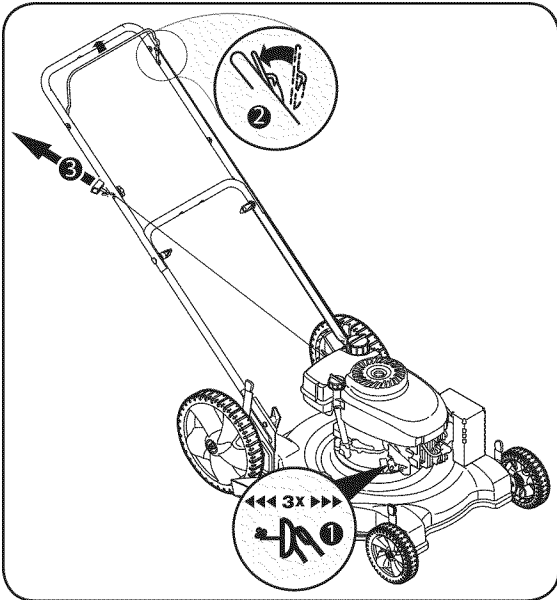

Figure 10

### To Stop Engine :

1. Release the blade control handle to stop the engine and blade.



**WARNING: The blade continues to rotate for a few seconds after the engine is shut off.**

2. Disconnect and ground the spark plug wire as instructed in the separate engine manual to prevent accidental starting while equipment is unattended.

### Using Your Lawn Mower

Be sure the lawn is clear of stones, sticks, wire, or other objects which could damage the lawn mower or the engine. Such objects could be accidentally thrown by the mower in any direction and cause serious personal injury to the operator and others.



**WARNING: If you strike a foreign object, stop the engine. Remove wire from the spark plug, thoroughly inspect the mower for any damage, and repair the damage before restarting and operating the mower. Extensive vibration of the mower during operation is an indication of damage. The unit should be promptly inspected and repaired.**

### Operating Tips

1. For best results and effective mulching, do not cut wet grass.
2. New grass, thick grass, or wet grass may require a narrower cut.
3. For a healthier lawn, never cut off more than one-third of the total length of the grass.
4. Your lawn should be cut in the fall as long as there is growth.
5. Adjust ground speed according to condition of lawn.
6. If the grass has been allowed to grow in excess of 4 inches, mulching is not recommended. Mow using the side discharge to reduce the grass height to 3-1/4 inches or less before mulching.

# 4

## Operating Your Lawn Mower



### WARNING

The operation of any lawn mower can result in foreign objects being thrown into the eyes, which can damage your eyes severely. Always wear safety glasses while operating the mower, or while performing any adjustments or repairs on it.

Be sure no one other than the operator is standing near the lawn mower while starting engine or operating mower. Never run engine indoors or in enclosed, poorly ventilated areas. Engine exhaust contains carbon monoxide, an odorless and deadly gas. Keep hands, feet, hair and loose clothing away from any moving parts on engine and lawn mower.

# 5

## Maintenance



### WARNING

Always stop engine, disconnect spark plug, and ground against engine before cleaning, lubricating or doing any kind of maintenance on your machine.



We do not recommend the use of pressure washers or garden hose to clean your unit. These may cause damage to electrical components, spindles, pulleys, bearings, or the engine. The use of water will result in shortened life and reduce serviceability.

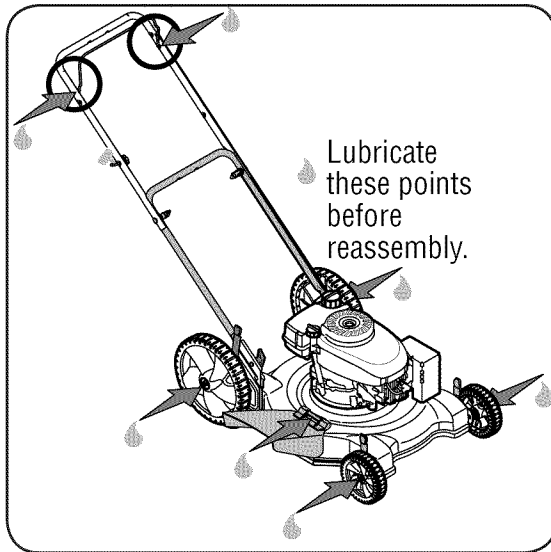

Figure 11

### General Recommendations

1. Always observe safety rules when performing any maintenance.
2. The warranty on this lawn mower does not cover items that have been subjected to operator abuse or negligence. To receive full value from warranty, operator must maintain the lawn mower as instructed here.
3. Changing of engine-governed speed will void engine warranty.
4. All adjustments should be checked at least once each season.
5. Periodically check all fasteners and make sure these are tight.

### Lubrication

1. Lubricate the pivot points on the blade control handle at least once a season with light oil. The blade control must operate freely in both directions. See Figure 11.
2. If your mower is equipped with ball bearing wheels, lubricate at least once a season with a light oil, all other types require no lubrication. However, if the wheels are removed for any reason, lubricate the surface of the axle bolt and the inner surface of the wheel with light automotive oil.
3. Lubricate the torsion spring and pivot point periodically with light oil to prevent rust. See Figure 11.
4. Follow the accompanying engine manual for lubrication schedule and instruction.

### Engine

1. Refer to the separate engine manual for engine maintenance instructions.
2. Maintain engine oil as instructed in the separate engine manual packed with your unit. Read and follow instructions carefully.
3. Under normal conditions service air cleaner as instructed in the separate engine manual packed with your unit. Clean every few hours under extremely dusty conditions. Poor engine performance and flooding usually indicates that the air cleaner should be serviced.
4. The spark plug should be cleaned and the gap reset once a season. Spark plug replacement is recommended at the start of each mowing season; check engine manual for correct plug type and gap specifications.

**NOTE:** This spark ignition system meets all requirements of the Canadian Interference-Causing Equipment Regulations.

5. Clean the engine regularly with a cloth or brush. Keep the cooling system (blower housing area) clean to permit proper air circulation which is essential to engine performance and life. Be certain to remove all grass, dirt and combustible debris from muffler area.

### Deck

The underside of the mower deck should be cleaned after each use to prevent a buildup of grass clippings, leaves, dirt or other matter. If this debris is allowed to accumulate, it will invite rust and corrosion, and may prevent proper mulching.

The deck may be cleaned by tilting the mower and scraping clean with a suitable tool (make certain the spark plug wire is disconnected).

### Blade Care



**WARNING:** When removing the cutting blade for sharpening or replacement, protect your hands with a pair of heavy gloves or use a heavy rag to hold the blade.

Periodically inspect the blade adapter for cracks, especially if you strike a foreign object. Replace when necessary. Follow the steps below for blade service:

1. Disconnect spark plug wire from spark plug.
2. Tip mower as specified in separate engine manual. If it does not specify turn mower on its side making sure that the air filter and the carburetor are up.
3. Remove the bolt and the blade bell support which hold the blade and the blade adapter to the engine crankshaft. See Figure 12.

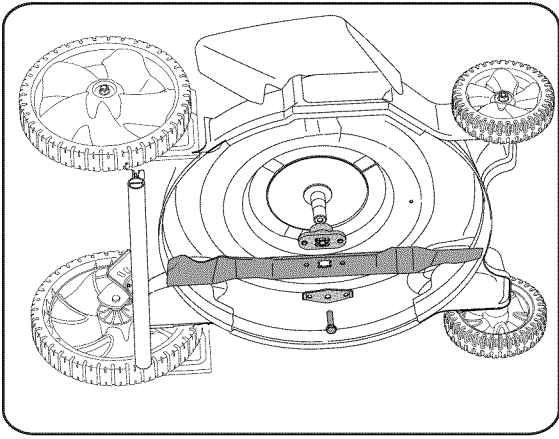

Figure 12

4. Remove blade and adapter from the crankshaft.
5. The blade may be resharpened by removing it and either grinding or filing the cutting edge keeping as close to the original bevel as possible. Do not attempt to sharpen the blade while it is still on the mower.
6. It is **extremely important** that each cutting edge receives an equal amount of grinding to prevent an unbalanced blade.

**NOTE:** Improper blade balance will result in excessive vibration causing eventual damage to the engine and mower. Be sure to carefully balance blade after sharpening. Possible damage resulting from blade unbalance condition is not the responsibility of the manufacturer.

**NOTE:** Always remove blade from the adapter for testing balance.

7. The blade can be tested for balance by balancing it on a round shaft screwdriver. Remove metal from the heavy side until it balances evenly.
8. Before reassembling the blade and the blade adapter to the unit, lubricate the engine crankshaft and the inner surface of the blade adapter with light oil.
9. Install the blade adapter on the crankshaft with the "star" away from the engine. See Figure 12. Place the blade with the side marked "bottom" (or with part number) facing away from the adapter. Align the blade bell support over the blade with the tabs in the holes of the blade and insert the hex bolt.

10. Tighten the hex bolt to the torque listed below:

#### Blade Mounting Torque

Center Bolt 450 in. lb. min., 600 in.lb. max.

To insure safe operation of your unit, ALL nuts and bolts must be checked periodically for correct tightness.

### Off-Season Storage

The following steps should be taken to prepare your lawn mower for storage.

1. Clean and lubricate mower thoroughly as described in the lubrication instructions.
2. We do not recommend the use of a pressure washer or garden hose to clean your unit.
3. Refer to engine manual for correct engine storage instructions.
4. Coat mower's cutting blade with chassis grease to prevent rusting.
5. Store mower in a dry, clean area. Do not store next to corrosive materials, such as fertilizer.

**NOTE:** When storing any type of power equipment in a poorly ventilated or metal storage shed, care should be taken to rust-proof the equipment. Using a light oil or silicone, coat the equipment, especially cables and all moving parts of your lawn mower before storage.

# 5

## Maintenance



### WARNING

When removing the cutting blade for sharpening or replacement, protect your hands with a pair of heavy gloves or use a heavy rag to hold the blade.

An unbalanced blade will cause excessive vibration when rotating at high speeds. It may cause damage to mower, and could break causing personal injury.



Cutting grass in sandy soil condition causes abrasive wear to the blade.

# 6

## Trouble Shooting



*For repairs beyond the minor adjustments listed here, contact an authorized service dealer.*

Problem	Cause	Remedy
Engine fails to start	<ol style="list-style-type: none"> <li>1. Blade control handle disengaged.</li> <li>2. Spark plug wire disconnected.</li> <li>3. Fuel tank empty or stale fuel.</li> <li>4. Engine not primed.</li> <li>5. Faulty spark plug.</li> <li>6. Blocked fuel line.</li> <li>7. Engine flooding.</li> </ol>	<ol style="list-style-type: none"> <li>1. Engage blade control handle.</li> <li>2. Connect wire to spark plug.</li> <li>3. Fill tank with clean, fresh gasoline.</li> <li>4. Refer to engine manual.</li> <li>5. Clean, adjust gap, or replace.</li> <li>6. Clean fuel line.</li> <li>7. Wait a few minutes to restart, but do not prime.</li> </ol>
Engine runs erratic	<ol style="list-style-type: none"> <li>1. Spark plug wire loose.</li> <li>2. Blocked fuel line or stale fuel.</li> <li>3. Gas cap vent plugged.</li> <li>4. Water or dirt in fuel system.</li> <li>5. Dirty air cleaner.</li> <li>6. Carburetor out of adjustment.</li> </ol>	<ol style="list-style-type: none"> <li>1. Connect and tighten spark plug wire.</li> <li>2. Clean fuel line; fill tank with clean, fresh gasoline.</li> <li>3. Clear vent.</li> <li>4. Drain fuel tank and carburetor. Refill with fresh fuel.</li> <li>5. Refer to engine manual.</li> <li>6. Refer to engine manual.</li> </ol>
Engine overheats	<ol style="list-style-type: none"> <li>1. Engine oil level low.</li> <li>2. Dirty air filter.</li> <li>3. Air flow restricted.</li> <li>4. Carburetor not adjusted properly.</li> </ol>	<ol style="list-style-type: none"> <li>1. Fill crankcase with proper oil.</li> <li>2. Refer to the engine manual packed with your unit.</li> <li>3. Remove blower housing and clean.</li> <li>4. Refer to engine manual.</li> </ol>
Occasional skip (hesitates) at high speed	<ol style="list-style-type: none"> <li>1. Spark plug gap too close.</li> <li>2. Carburetor idle mixture adjustment improperly set.</li> </ol>	<ol style="list-style-type: none"> <li>1. Adjust gap to .030". Refer to engine manual.</li> <li>2. Refer to engine manual.</li> </ol>
Idles poorly	<ol style="list-style-type: none"> <li>1. Spark plug fouled, faulty or gap too wide.</li> <li>2. Carburetor improperly adjusted.</li> <li>3. Dirty air cleaner.</li> </ol>	<ol style="list-style-type: none"> <li>1. Reset gap to .030" or replace spark plug. Refer to engine manual.</li> <li>2. Refer to engine manual.</li> <li>3. Refer to engine manual.</li> </ol>
Excessive vibration	<ol style="list-style-type: none"> <li>1. Cutting Blade loose or unbalanced.</li> <li>2. Bent cutting blade.</li> </ol>	<ol style="list-style-type: none"> <li>1. Tighten blade and adapter. Balance blade</li> <li>2. Replace blade.</li> </ol>
Mower will not mulch grass	<ol style="list-style-type: none"> <li>1. Wet grass.</li> <li>2. Excessive high grass.</li> <li>3. Dull blade.</li> </ol>	<ol style="list-style-type: none"> <li>1. Do not mow when grass is wet; wait until later to cut.</li> <li>2. Mow once at a high cutting height, then mow again at desired height or make a narrower cutting path.</li> <li>3. Sharpen or replace blade.</li> </ol>
Uneven cut	<ol style="list-style-type: none"> <li>1. Wheels not positioned correctly.</li> <li>2. Dull blade.</li> </ol>	<ol style="list-style-type: none"> <li>1. Place all four wheels in same height position.</li> <li>2. Sharpen or replace blade.</li> </ol>

---

# MANUFACTURER'S LIMITED WARRANTY FOR

The limited warranty set forth below is given by MTD LLC with respect to new merchandise purchased and used in the United States and/or its territories and possessions, and by MTD Products Limited with respect to new merchandise purchased and used in Canada and/or its territories and possessions (either entity respectively, "MTD").

MTD warrants this product (excluding its normal wear parts as described below) against defects in material and workmanship for a period of two (2) years commencing on the date of original purchase and will, at its option, repair or replace, free of charge, any part found to be defective in materials or workmanship. This limited warranty shall only apply if this product has been operated and maintained in accordance with the Operator's Manual furnished with the product, and has not been subject to misuse, abuse, commercial use, neglect, accident, improper maintenance, alteration, vandalism, theft, fire, water, or damage because of other peril or natural disaster. Damage resulting from the installation or use of any part, accessory or attachment not approved by MTD for use with the product(s) covered by this manual will void your warranty as to any resulting damage.

Normal wear parts are warranted to be free from defects in material and workmanship for a period of thirty (30) days from the date of purchase. Normal wear parts include, but are not limited to items such as: batteries, belts, blades, blade adapters, grass bags, rider deck wheels, seats, snow thrower skid shoes, friction wheels, shave plates, auger spiral rubber and tires.

**HOW TO OBTAIN SERVICE:** Warranty service is available, WITH PROOF OF PURCHASE, through your local authorized service dealer. To locate the dealer in your area;

**In the U.S.A.:** Check your Yellow Pages, or contact MTD LLC at P.O. Box 361131, Cleveland, Ohio 44136-0019, or call 1-800-800-7310 or 1-330-220-4683 or log on to our Web site at [www.mtdproducts.com](http://www.mtdproducts.com).

**In Canada:** Contact MTD Products Limited, Kitchener, ON N2G 4J1, or call 1-800-668-1238 or log on to our Web site at [www.mtdcanada.com](http://www.mtdcanada.com).

This limited warranty does not provide coverage in the following cases:

- a. The engine or component parts thereof. These items may carry a separate manufacturer's warranty. Refer to applicable manufacturer's warranty for terms and conditions.
- b. Log splitter pumps, valves, and cylinders have a separate one-year warranty.
- c. Routine maintenance items such as lubricants, filters, blade sharpening, tune-ups, brake adjustments, clutch adjustments, deck adjustments, and normal deterioration of the exterior finish due to use or exposure.
- d. Service completed by someone other than an authorized service dealer.
- e. MTD does not extend any warranty for products sold or exported outside of the United States and/or Canada, and their respective possessions and territories, except those sold through MTD's authorized channels of export distribution.
- f. Replacement parts that are not genuine MTD parts.
- g. Transportation charges and service calls.
- h. If Products are used commercially. (MTD may separately offer Limited Commercial Warranties on certain select products. Ask your dealer or retailer for details or contact MTD Service for more information.)

**No implied warranty, including any implied warranty of merchantability of fitness for a particular purpose, applies after the applicable period of express written warranty above as to the parts as identified. No other express warranty, whether written or oral, except as mentioned above, given by any person or entity, including a dealer or retailer, with respect to any product, shall bind MTD. During the period of the warranty, the exclusive remedy is repair or replacement of the product as set forth above.**

**The provisions as set forth in this warranty provide the sole and exclusive remedy arising from the sale. MTD shall not be liable for incidental or consequential loss or damage including, without limitation, expenses incurred for substitute or replacement lawn care services or for rental expenses to temporarily replace a warranted product.**

Some jurisdictions do not allow the exclusion or limitation of incidental or consequential damages, or limitations on how long an implied warranty lasts, so the above exclusions or limitations may not apply to you.

In no event shall recovery of any kind be greater than the amount of the purchase price of the product sold. **Alteration of safety features of the product shall void this warranty.** You assume the risk and liability for loss, damage, or injury to you and your property and/or to others and their property arising out of the misuse or inability to use the product.

This limited warranty shall not extend to anyone other than the original purchaser or to the person for whom it was purchased as a gift.

**HOW LOCAL LAWS RELATE TO THIS WARRANTY:** This limited warranty gives you specific legal rights, and you may also have other rights that vary in different jurisdictions.

**IMPORTANT:** Owner must present Original Proof of Purchase to obtain warranty coverage.

**MTD LLC, P.O. BOX 361131 CLEVELAND, OHIO 44136-0019; Phone: 1-800-800-7310, 1-330-220-4683  
MTD Products Ltd., P. O. BOX 1386, KITCHENER, ON N2G 4J1; Phone: 1-800-668-1238**

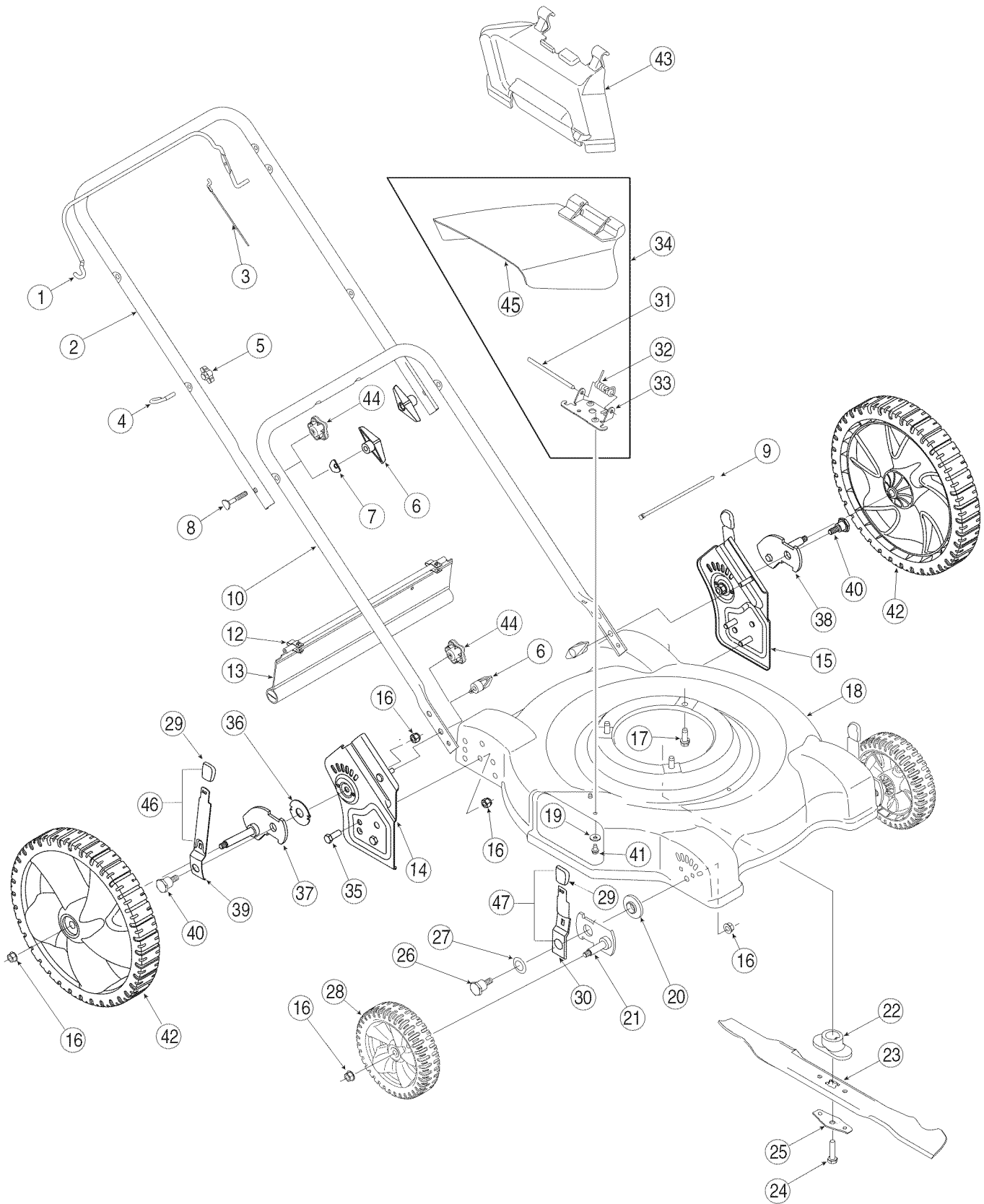

REF NO. N° DE RÉF	PART NO. N° DE PIÈCE	DESCRIPTION	DESCRIPTION
1	747-1161A	Blade Control Handle	Poignée de commande de la lame
2	749-1092A	Upper Handle	Guidon supérieur
3	746-0946	Control Cable 48.25" Lg.	Câble de la commande 48,25 po de lg.
4	710-1205	Rope Guide Bolt	Boulon de guidage de cordon
5	720-0279	Knob - ERS Guide 1/4-20	Bouton - 1/4-20
6	720-0284	Handle Knob Assembly	Bouton
7	736-0451	Saddle Wash. .320 ID x .937 OD	Rondelle selle 0,320 DI x 0,937 DE
8	710-1174	Carriage Bolt 5/16-18 x 2.0	Boulon ordinaire 5/16-18 x 2,0
9	725-0157	Cable Tie	Attache-câble
10	749-04037	Lower Handle	Guidon inférieur
11	731-0981A	Hub Cap Grey Radial	Moyeu de chapeau - gris
12	17098	Hinge Clip	Attache
13	731-2537	Trail Shield	Abattant de protection arrière
14	682-3062A	RH Handle Bracket Assembly	Support de montage du guidon CD
15	682-3063A	LH Handle Bracket Assembly	Support de montage du guidon CG
16	712-04065	Flanged Lock Nut 3/8-16	Écrou de blocage 3/8-16
17	710-0654A	Hex Wash HD Tap Scr 3/8-16 x .88	Vis autotaraudée 3/8-16 x 0,88
18	687-02048	Deck Assembly 22" (without logo)	Plateau de coupe de 22 po (sans logo)
19	736-0270	Cupp. Wash. .265 ID x .75 OD x .062	Rondelle creuse 0,265 DI x 0,75 DE x 0,062
20	741-0751	Height Adjuster Bearing	Roulement
21	687-02094	Pivot Bar	Barre de pivot
22	748-04096	Blade Adapter	Adaptateur de la lame
23	742-0742A	Mulching Blade 22"	Lame déchiqueteuse 22 po
24	710-1044	Hex Screw 3/8-24 x 1.5" Lg. (Gr. 8)	Vis à tête hex. 3/8-24 x 1,50 po de lg (Qual. 8)
25	736-0524B	Blade Bell Support	Support de la lame
26	738-1172	Shoulder Screw 3/8-16	Vis à épaulement 3/8-16
27	736-0741	Cupped Washer .401 ID x .870 OD	Rondelle creuse 0,401 DI x 0,870 DE
28	734-1988	Wheel Assembly Complete 7 x 1.8	Ensemble de roue complet 7 x 1,80
29	720-0426	Height Adjuster Knob	Bouton
30	732-1026	Spring Lever	Levier de ressort
31	747-0710	Hinge Pin	Axe de charnière
32	732-1014	Torsion Spring	Ressort de torsion
33	17032A	Deflector Chute Adapter	Adaptateur de déflecteur de la goutte
34	731-1034B	Side Dis. Chute Ass'y	Déflecteur lateral complet
35	710-0216	Hex Cap Screw 3/8-16 x .75	Vis à chapeau à six pans de 3/8-16 x 0,75
36	741-0717	Thrust Bearing .688 ID x 1.938 OD	Palier de butée 0,688 DI x 1,938 DE
37	687-02080	RH Rear Pivot Arm Assembly	Bras de pivot arrière CD
38	687-02079	LH Rear Pivot Arm Assembly	Bras de pivot arrière CG
39	732-0984B	Rear Spring Lever	Levier à ressort arrière
40	738-1127	Shoulder Screw 3/8-16 x .442	Vis à épaulement 3/8-16 x 0,442
41	710-0599	Hex Wash S-Tapp Scr 1/4-20 x .50	Vis autotaraudeuse à rondelle hex. de 1/4-20 x 0,5
42	734-04082	Wheel Assembly 12 x 1.8 Bar Grey	Ensemble de roue 12 x 1,80 barre gris
43	631-04045	Mulch Plug	Plaque de déchiquetage
44	720-04072	Knob - Star 5/16-18	Bouton - étoile 5/16-18
45	731-1035B	Chute Deflector	Adaptateur de déflecteur
46	687-02052	Rear Height Lever Ass'y	Ensemble d'levier arrière
47	687-02051	Front Height Lever Ass'y	Ensemble d'levier avant

11A-500  
10.18.05

# 7

## Parts List Pièces détachées



For parts and/or accessories refer to customer support on page 2.

Adressez-vous au «Service après-vente» à la page 2 pour ce qui concerne les pièces et/ou accessoires.