

Operator's Manual

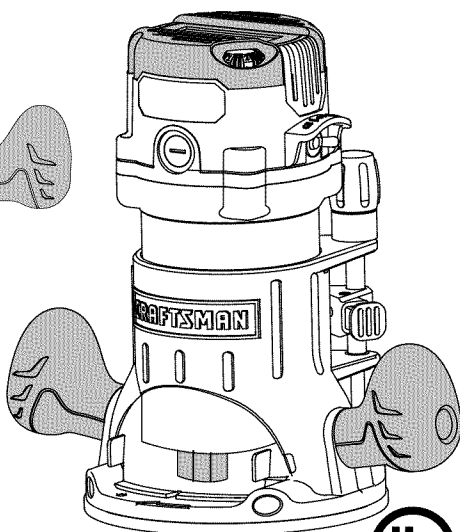

# 12.0 Amp, Variable Speed 2 Peak HP Router Combo With Fixed Base and Plunge Base

Model No. 320.27683

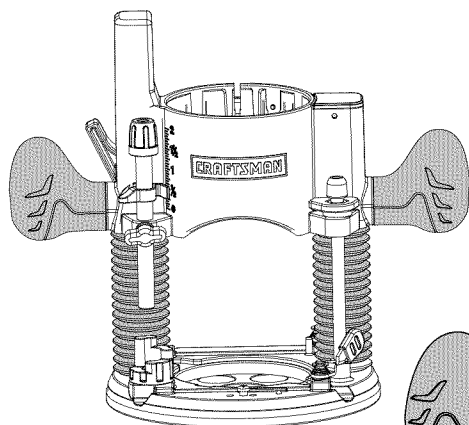

- WARRANTY
- SAFETY
- UNPACKING
- DESCRIPTION
- OPERATION
- MAINTENANCE
- TROUBLESHOOTING
- ESPAÑOL

**⚠ WARNING:** To reduce the risk of injury, the user must read and understand the Operator's manual before using this product.

Sears Brands Management Corporation, Hoffman Estates, IL 60179 U.S.A.

[www.craftsman.com](http://www.craftsman.com)

## TABLE OF CONTENTS

Warranty	page 2
Safety Symbols	page 3
Safety Instructions	page 5-10
Unpacking	page 10-14
Description	page 14-29
Operation	page 14-29
Maintenance	page 30-31
Troubleshooting	page 32
Exploded View and Part List	page 33-37
Sears Repair Parts Phone Number	Back Cover

### **CRAFTSMAN ONE YEAR LIMITED WARRANTY**

FOR ONE YEAR from the date of purchase, this product is warranted against any defects in material or workmanship. With proof of purchase, defective product will be replaced free of charge.

**For warranty coverage details to obtain free replacement, visit the web site: [www.craftsman.com](http://www.craftsman.com)**

This warranty is void if this product is ever used while providing commercial services or if rented to another person.

This warranty gives you specific legal rights, and you may also have other rights which vary from state to state.

Sears Brands Management Corporation, Hoffman Estates, IL 60179

**⚠ WARNING:** Some dust created by using power tools contains chemicals known to the state of California to cause cancer and birth defects or other reproductive harm.

**SAVE THESE INSTRUCTIONS!**

**READ ALL INSTRUCTIONS!**

This Router has many features for making its use more pleasant and enjoyable. Safety, performance, and dependability have been given top priority in the design of this product, making it easy to maintain and operate.

## SAFETY SYMBOLS

The purpose of safety symbols is to attract your attention to possible dangers. The safety symbols and the explanations with them deserve your careful attention and understanding. The symbol warnings do not, by themselves, eliminate any danger. The instructions and warnings they give are no substitutes for proper accident prevention measures.

**⚠ WARNING:** Be sure to read and understand all safety instructions in this manual, including all safety alert symbols such as “**DANGER**,” “**WARNING**,” and “**CAUTION**” before using this router. Failure to follow all instructions listed in this manual may result in electric shock, fire and/or serious personal injury.

### SYMBOL SIGNAL MEANING

**⚠ SAFETY ALERT SYMBOL:** Indicates **DANGER, WARNING, OR CAUTION**. May be used in conjunction with other symbols or pictographs.

**⚠ DANGER:** Indicates a hazardous situation which, if not avoided, will result in death or serious injury. This signal word is to be limited to the most extreme situations. Always follow the safety precautions to reduce the risk of fire, electric shock, and personal injury.

**⚠ WARNING:** Indicates a hazardous situation which, if not avoided, could result in death or serious injury. Always follow the safety precautions to reduce the risk of fire, electric shock, and personal injury.

**⚠ CAUTION:** Indicates a hazardous situation which, if not avoided, could result in minor or moderate injury. It may also be used without the safety alert symbol as an alternative to “NOTICE”<sup>2</sup>. Always follow the safety precautions to reduce the risk of fire, electric shock, and personal injury.

**NOTICE:** “NOTICE” is the preferred signal word to address practices not related to personal injury. The safety alert symbol not be used with this signal word. As an alternative to “NOTICE”, the word “CAUTION” without the safety alert symbol may be used to indicate a message not related to personal injury.<sup>2</sup>

### Damage Prevention and Information Messages

These inform the user of important information and/or instructions that could lead to equipment or other property damage if they are not followed. Each message is preceded by the word “NOTE,” as in the example below:

**NOTE:** Equipment and/or property damage may result if these instructions are not followed.

**⚠ WARNING:** To ensure safety and reliability, all repairs should be performed at a Sears Parts & Repair Service Center.

**⚠ WARNING:** The operation of any power tools can result in foreign objects being thrown into your eyes, which can result in severe eye damage. Before beginning power tool operation, always wear safety goggles or safety glasses with side shield and a full face shield when needed. We recommend a Wide Vision Safety Mask for use over eyeglasses or standard safety glasses with side shields. Always use eye protection which is marked to comply with ANSI Z87.1



## SAVE THESE INSTRUCTIONS

Some of these following symbols may be used on this tool. Please study them and learn their meaning. Proper interpretation of these symbols will allow you to operate the tool better and more safely.

SYMBOL	NAME	DESIGNATION/EXPLANATION
V	Volts	Voltage
A	Amperes	Current
Hz	Hertz	Frequency (cycles per second)
W	Watt	Power
min	Minutes	Time
~	Alternating Current	Type of current
≡	Direct Current	Type or a characteristic of current
$n_0$	No Load Speed	Rotational speed, at no load
	Class II Construction	Double-insulated construction
.../min	Per Minute	Revolutions, strokes, surface speed, orbits, etc., per minute
	Wet Conditions Alert	Do not expose to rain or use in damp locations.
	Read The Operator's Manual	To reduce the risk of injury, user must read and understand operator's manual before using this product.
	Eye Protection	Always wear safety goggles or safety glasses with side shields and a full face shield when operating this product.
	Safety Alert	Precautions that involve your safety.
	No Hands Symbol	Failure to keep your hands away from the blade will result in serious personal injury.
	No Hands Symbol	Failure to keep your hands away from the blade will result in serious personal injury.
	No Hands Symbol	Failure to keep your hands away from the blade will result in serious personal injury.
	No Hands Symbol	Failure to keep your hands away from the blade will result in serious personal injury.
	Hot Surface	To reduce the risk of injury or damage, avoid contact with any hot surface.

# SAFETY INSTRUCTIONS

## GENERAL POWER TOOL SAFETY WARNINGS

**⚠ WARNING: Read all safety warnings and instructions.** Failure to follow the warnings and instructions may result in electric shock, fire and/or serious injury.

- **Know your power tool. Read the operator's manual carefully.** Learn the applications, as well as the specific potential hazards related to this tool. Following this rule will reduce the risk of electric shock, fire or serious injury.
- **Save these instructions.** Refer to them frequently and use them to instruct others who may use this tool. If someone borrows this tool, make sure they have these instructions also.

The term "power tool" in the warnings refers to your mains-operated (corded) power tool or battery-operated (cordless) power tool.

## WORK AREA SAFETY

- **Keep the work area clean and well lit.** Cluttered or dark areas invite accidents.
- **Do not operate power tools in explosive atmospheres, such as in the presence of flammable liquids, gases or dust.** Power tools create sparks which may ignite the dust or fumes.
- **Keep children and bystanders away while operating a power tool.** Distractions can cause you to lose control.

## ELECTRICAL SAFETY

- **Power tool plugs must match the outlet. Never modify the plug in any way. Do not use any adapter plugs with earthed (grounded) power tools.** Unmodified plugs and matching outlets will reduce risk of electric shock
- **Avoid body contact with earthed or grounded surfaces such as pipes, radiators, ranges and refrigerators.** There is an increased risk of electric shock if your body is earthed or grounded.
- **Do not expose power tools to rain or wet conditions.** Water entering a power tool will increase the risk of electric shock.
- **Do not abuse the cord. Never use the cord for carrying, pulling or unplugging the power tool. Keep the cord away from heat, oil, sharp edges or moving parts.** Damaged or entangled cords increase the risk of electric shock.
- **Inspect the tool cords periodically and, if damaged, have them repaired at your nearest Sears Service Center. Be aware of the cord location.**
- **When operating a power tool outdoors, use an extension cord suitable for outdoor use.** Use of a cord suitable for outdoor use reduces the risk of electric shock.
- **If operating a power tool in a damp location is unavoidable, use a ground fault circuit interrupter (GFCI) protected supply.** Use of a GFCI reduces the risk of electric shock.

## PERSONAL SAFETY

- **Stay alert, watch what you are doing and use common sense when operating a power tool. Do not use the tool while tired or under the influence of drugs, alcohol, or medication.** A moment of inattention while operating power tools may result in serious personal injury.
- **Know your power tool. Read the operator's manual carefully.** Learn the applications, as well as the specific potential hazards related to this tool. Following this rule will reduce the risk of electric shock, fire or serious injury.
- **Always wear safety glasses or eye shields when using this router.** Everyday eyeglasses have only impact-resistant lenses; they are not safety glasses.
- **Protect your lungs.** Wear a face mask or dust mask if the operation is dusty.
- **Protect your hearing.** Wear appropriate personal hearing protection during use. Under some conditions noise from this product may contribute to hearing loss.
- **All visitors and bystanders must** wear the same safety equipment that the operator of the saw wears.
- **Use personal protective equipment. Always wear eye protection.** Protective equipment such as dust mask, non-skid safety shoes, hard hat, or hearing protection used for appropriate conditions will reduce personal injuries.
- **Prevent unintentional starting. Ensure that the switch is in the OFF-position before connecting to a power source and/or battery, picking up or carrying the tool.** Carrying power tools with your finger on the switch or energizing power tools that have the switch on invites accidents.
- **Remove any adjusting key or wrench before turning the power tool on.** A wrench or a key left attached to a rotating part of the power tool may result in personal injury.
- **Do not overreach. Keep proper footing and balance at all times.** This enables better control of the power tool in unexpected situations.
- **Dress properly. Do not wear loose clothing or jewelry. Keep your hair, clothing and gloves away from moving parts.** Loose clothes, jewelry or long hair can be caught in moving parts.
- **If devices are provided for the connection of dust extraction and collection facilities, ensure that these are connected and properly used.** Use of these devices can reduce dust-related hazards.

## POWER TOOL USE AND CARE

- **Do not force the power tool. Use the correct power tool for your application.** The correct power tool will do the job better and more safely at the rate for which it was designed.
- **Do not use the power tool if the switch does not turn it on and off.** Any power tool that cannot be controlled with the switch is dangerous and must be repaired.

- **Always check the tool for damaged parts before use.** Before further use of the tool, a guard or other part that is damaged should be carefully checked to determine if it will operate properly and perform its intended function. Check for misalignment or binding of moving parts, breakage of parts, and any other condition that may affect the tool's operation. A guard or other part that is damaged should be properly repaired or replaced at a Sears Service Center.
- **Disconnect the plug from the power source and/or the battery from the power tool before making any adjustments, changing accessories, or storing power tools.** Such preventive safety measures reduce the risk of starting the power tool accidentally.
- **Store idle power tools out of the reach of children and do not allow persons unfamiliar with the power tool or these instructions to operate the power tool.** Power tools are dangerous in the hands of untrained users.
- **Maintain power tools before use.** Many accidents are caused by poorly maintained power tools.
- **Keep cutting tools sharp and clean.** Properly maintained cutting tools with sharp cutting edges are less likely to bind and are easier to control.
- **Use the power tool, accessories, tool bits, etc., in accordance with these instructions, taking into account the working conditions and the work to be performed.** Use of the power tool for operations different from those intended could result in a hazardous situation.

 **WARNING:** When using power tools, basic safety precautions should always be followed to reduce the risk of fire, electric shock, and personal injury.

 **WARNING:** The operation of any tool can result in foreign objects being propelled into your eyes, resulting in severe eye damage. When operating power tool, always wear safety goggles or safety glasses with side shields and a full face shield when needed.

 **WARNING:** If any parts are missing, do not operate the tool until the missing parts have been replaced. Doing so could result in serious personal injury.

## SERVICE SAFETY

- **Have your power tool serviced by a qualified repair person using only identical replacement parts.** This will ensure that the safety of the power tool is maintained.
- **If any part of this router is missing or should break, bend,** or fail in any way; or should any electrical component fail to perform properly: shut off the power switch and remove the plug from the power source and have the missing, damaged, or failed parts replaced before resuming operation.
- **Tool service** must be performed only at a Sears Parts & Repair Service Center. Service or maintenance performed by unqualified personnel could result in a risk of injury.

- **Use only identical replacement parts** when servicing a tool. Follow the instructions in the maintenance section of this manual. Use of unauthorized parts or failure to follow maintenance instructions may create a risk of electric shock or injury.

## **SPECIFIC SAFETY RULES FOR ROUTER**

- **Hold power tools by the insulated gripping surfaces** when performing an operation where the cutting tool may contact hidden wiring or its own cord. Contact with a “live” wire will make exposed metal parts of the tool “live” and shock the operator.
- **Use clamps or another practical way to support and secure the workpiece to a stable platform.** Holding the work by hand or against your body leaves it unstable and may lead to loss of control.
- **Maintain a firm grip** on the router with both hands to resist starting torque.
- **Never attempt to use the router motor without first installing it in an approved base.** Failure to heed this warning could result in personal injury and damage to the motor.
- **Make sure that the motor housing does not move up or down when clamped in the fixed base. If the motor is not securely clamped into the base, adjustments will not be accurate.**
- **Do not hand-hold the router in an upside down or horizontal position.** The motor can separate from the base if it is not properly attached according to the instructions.
- **Tighten the collets/nut securely to prevent the cutter bit from slipping.** If the collet/nut is not securely tightened, the cutter bit may detach during use, causing serious personal injury.
- **Never tighten a collet/nut without a cutter bit installed in the collet/nut.**
- **Never hold the piece being cut in your hands or across your legs.** It is important to support and clamp the workpiece properly in order to minimize body exposure, bit binding, and loss of control.
- **Always keep the chip shield clean and in place.**
- **Stay alert and clear the router cutter bit path of any obstructions before starting the motor. Keep the cutting area clear of all foreign objects while the motor is running.**
- **Inspect and remove all nails from lumber before routing.**
- **Check to see that the cord will not “hang up” during routing operation.**
- **Make sure that the cutter bit is not in contact with the workpiece before the switch is turned on.**
- **The bit must always be running at the full selected speed before contacting the workpiece.**
- **Keep hands clear of the cutter bit when the motor is running to prevent personal injury.**



- **Provide clearance under the workpiece for the router cutter bit when through-cutting.**
- **Keep cutting pressure constant.** Do not overload the motor.
- **Use only sharp cutter bits that are not chipped or cracked.** Blunt cutter bits will cause stalling and burn the workpiece.
- **Never use this router motor with a cutter bit larger than 3-1/2 inches in diameter.**
- **Always use cutter bits that are designed for this router. Never use cutter bits that are larger in diameter than the opening in the router sub-base.** Cutter bits that have cutter diameters larger than the opening could cause possible loss of control or create other hazardous condition that could cause serious personal injury.
- **The sub-bases on this router have openings of 1-1/4 inch in diameter.** To use cutter bits with a larger diameter, install and use a sub-base with a larger opening (sold separately at Sears stores or other Craftsman outlets).
- **Do not use large router cutter bits for freehand routing.** Use of large cutter bits when freehand routing could cause loss of control or create hazardous conditions that could result in serious personal injury. If using a router table, large bits should be used for edging only.
- **Be sure that the cutter bit is centered in a template guide (sold separately) prior to template guide applications** to avoid personal injury or damage to finished work.
- **Do not remove more than 1/8-inch in a single pass.** Excessive depth of cut can result in loss of control that could result in personal injury.
- **After completing a cut, turn motor OFF and let it come to complete stop before removing router from workpiece.**
- **Let the motor come to a complete stop before putting the router down.** Cutter bits coast after power is turned off.
- **Only use router tables with on-board switch controlled receptacles.** Failure to use router tables with all the appropriate safety features could result in serious personal injury.
- **Disconnect** the tool from the power source before making any adjustments or changing cutter bits.
- **If you are changing a bit immediately after use, be careful not to touch the collet/nut or cutter bit with your hands or fingers.** The heat buildup from cutting could cause severe burns. Always use the wrench provided.
- **Avoid “climb cutting.” see “OPERATION” section in this manual.** “Climb cutting” increases the chance for loss of control resulting in possible serious injury.

## UNPACKING

**⚠ WARNING:** Your Router should never be connected to the power source when you are assembling parts, making adjustments, installing or removing bits, cleaning, or when it is not in use. Disconnecting the Router will prevent accidental starting, which could cause serious personal injury.





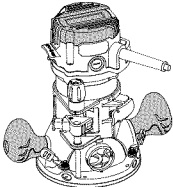

When unpacking the box, do not discard any packing materials until all of the contents are accounted for:

1. Carefully lift the router out of the carton and place it on a stable, flat surface.
2. Open the box to locate the following:
  - Plunge base
  - 2 Vacuum ports: one each for plunge and fixed base
  - 1/4-in. collet/nut (the 1/2-in. collet/nut is already installed on the router)
  - 2 screws for attaching the vacuum ports to plunge base
  - Collet/nut wrench
  - 2 Chip shields: one each for the fixed and plunge bases
  - Edge guide
  - Depth-adjustment wrench
  - Carry case
  - Manual
3. Inspect the items carefully to make sure that no breakage or damage has occurred during shipping. If any of the items mentioned is missing, (refer to "PARTS LIST" illustration), return the Router to your nearest Sears store to have the Router replaced.

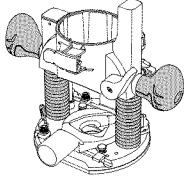
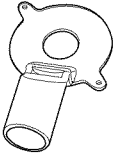
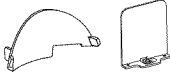
**⚠ WARNING:** If any part is broken or missing, do not attempt to assemble the router, plug in the power cord, or operate the router until the broken or missing part is replaced. Failure to do so could result in serious injury.

### CARTON CONTENTS (Fig.1)

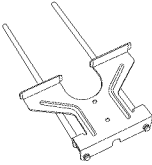
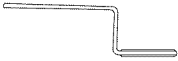
	Fixed Base and Router motor with 1/2-in. Collet/Nut
---	---

	<p>Plunge Base</p>
	<p>Vacuum Port for Plunge Base</p>
	<p>2 chip shields</p>
	<p>Vacuum Port for fixed Base</p>
	<p>2 screws (for attaching port to plunge base)</p>
	<p>1/4-in. and 1/2-in. Collet/Nut</p>
	<p>Edge Guide</p>
	<p>Depth-Adjustment Wrench</p>
	<p>Collet/Nut Wrench</p>

# DESCRIPTION

## KNOW YOUR ROUTER COMBO (Fig.2)

**NOTE:** Before attempting to use your router, familiarize yourself with all of the operating features and safety requirements.

Your router has a precision-built electric motor and it should only be connected to a 120-volt, 60-Hz AC power supply (normal household current). Do not operate on direct current (DC). This large voltage drop will cause a loss of power and the motor will overheat. If the router does not operate when plugged into a correct 120-volt, 60-Hz AC only outlet, check the power supply. This router has an 8-ft., 2-wire power cord (no adapter needed).

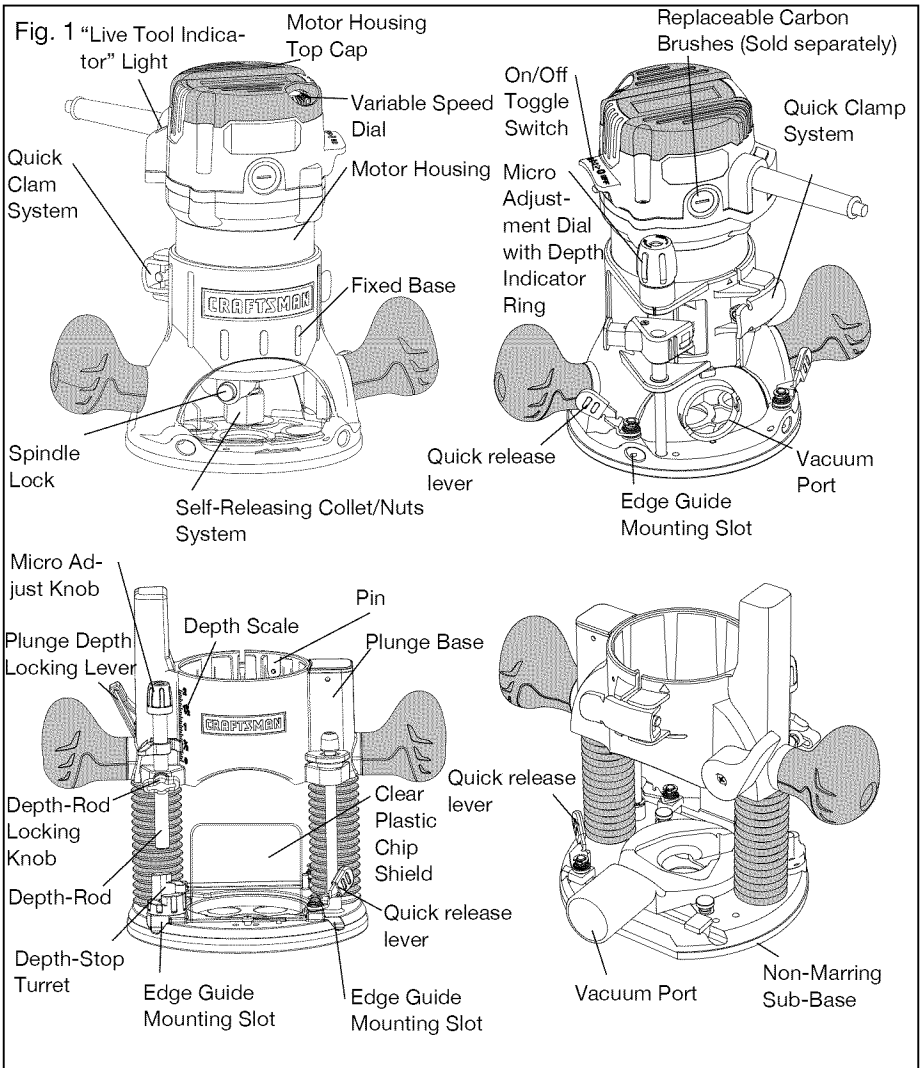

**⚠ WARNING:** Do not allow familiarity with the router to cause a lack of alertness. A fraction of a second of carelessness is enough to cause severe injury.

<b>PRODUCT SPECIFICATIONS</b>	
Rating	12.0 Amps
No-Load Speed	10000-25000 RPM
Peak HP	2.0
Input	120V, 60Hz AC
Collets/Nuts and Cutter bit Shank Diameters	1/4 in. and 1/2 in.
Fixed Base Diameter	6-inches
Plunge Base Diameter	6-11/16 inches
Sub-Base Opening (Diameter for cutter bit use)	1-1/4 inches (for both bases)
Sub-Base Thickness	1/4 inch (6mm) (for both bases)
Fixed Base Depth of Cut	1-3/4 inches (45mm)
Plunge Base Depth of Cut	2-1/8 inches (55mm)

**⚠ WARNING:** The safe use of this product requires an understanding of the information on the tool and in this operator's manual, as well as knowledge of the project you are attempting. Before use of this product, familiarize yourself with all operating features and safety rules.

The Router Combo has the following features:

1. 12.0 Amp, 2 Peak HP, **Variable Speed Motor** runs at 10,000 to 25,000 RPM (no-load speed).
2. **Variable Speed Dial** for matching the speed to the material and cutter bit size.
3. **Electronic Feedback Circuitry** provides soft starts for longer motor life and maintains constant speed under load to help produce a high-quality finish in all materials.
4. **Quick-clamp System** allows motor to be changed from the fixed to plunge base and back without the use of tools.
5. Fixed Base features **Coarse and Micro-Depth Adjustments** for accurate set-ups.
6. Plunge Base features **Fine and Micro Depth Rod Adjustments** with **Turret Stops** for precise set-ups and repetitive cutting.
7. **Smooth Plunge Action** lowers the bit into the workpiece at 90° for more accurate cutting.

8. Protective Plunge Post Bellows protect guideposts from woodchips, dust, and moisture.
9. **Spindle Lock** for easy 1-wrench bit changes. Includes **1/4 and 1/2-inch Self-Releasing Collets/Nuts** for use with a wide variety of 1/4-in. and 1/2-in. router bits, sold separately.
10. **100% Ball Bearings** for smooth, efficient operation and long life.
11. Both bases feature **Ergonomically Designed Handles** with soft grip for comfort, maximum control with less vibration.
12. Both bases feature **Large Base Openings and Large Chip Shields**, combined with **3 LED Worklights** on the motor housing to enhance the visibility of bit and workpiece.
13. **Durable Non-marring Sub-bases** glide smoothly over the workpiece. Sub-bases have cutter bit opening of 1 1/4-inches. **Do Not Use** a bit with a cutter diameter larger than 1-1/4 inch with the included sub-bases, as it will not pass through the sub-base opening!
14. Motor Housing constructed of **Precision Milled Cast Aluminum** for strength and exact fit into bases.
15. **High-impact Resistant Motor Housing Top Cap and Handles** on bases help protect tool from damage.
16. **Heavy-duty Edge Guide** for most routing applications such as decorative edging, grooving, dadoing, slotting and straight edge planing/trimming.
17. **Conveniently located On/Off Toggle Switch**, side mounted for added visibility, easy access.
18. **Vacuum Ports** allow both bases to attach to a 1-1/4-inch vac hose attachment, sold separately.
19. **“LIVE TOOL Indicator”** Light is green when router is plugged into a power source. Light is located on motor housing top cap next to power cord inlet.
20. **Replaceable Carbon Brushes** (sold separately) for dependable service.
21. Includes carry bag for easy carrying and storage.

## OPERATION

**NOTE:** This tool is shipped completely assembled. To change the router motor from one base to another, install or remove cutter bits or add accessories such as vacuum adapters or install the heavy-duty edge guide, see the following instructions.

### SELECTING THE CUTTER BIT

This router comes with 1/4-inch. and 1/2-inch. collets/nuts that accept cutter bits with 1/4 inch and 1/2 inch shanks, respectively.

**▲ WARNING:** Do not use a router cutter bit that has a cutter bit diameter larger than 1-1/4 inches with the sub-bases that are supplied with this router. A larger cutter bit will not fit through the sub-base opening, will cause damage to the sub-base and the motor and could cause serious personal injury to the operator.

**NOTE:** The sub-base installed on this router has an opening of 1-1/4 inches. To use cutter bits with larger diameters, use sub-bases with larger openings, sold separately at Sears stores or other Craftsman outlets.

**▲ WARNING:** Always turn the motor off and unplug the router before making any adjustments or installing accessories. Failure to unplug the router could result in accidental starting which can cause serious personal injury.

### INSTALLING AND REMOVING THE CUTTER BIT

#### INSTALLING THE CUTTER BIT FOR FIXED BASE

1. Turn the motor off and unplug the router from the power source.
2. Remove the motor housing from fixed base.

**NOTE:** See the instructions for removing the motor housing from the fixed base in this manual.

3. Set the motor upside down on its top cap, with the collet/nut pointing up.
4. Press the spindle-lock button to engage and lock the spindle shaft and collet/nut (Fig. 3).
5. Place the wrench on the collet/nut and turn it counter-clockwise to slightly loosen the collet/nut to accept the cutter bit shank.

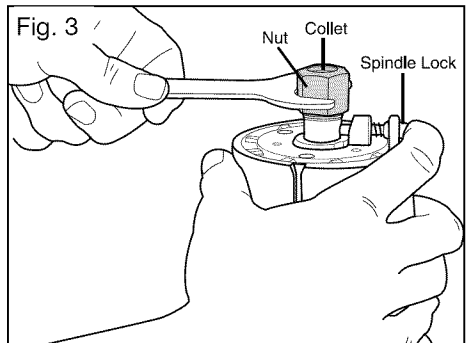

6. Insert the cutter bit shank into the collet/nut assembly as far as it will go, then back the shank out until the cutters are approximately 1/8 to 1/4 inch away from the face of the collet/nut (Fig. 3a & Fig. 3b).

**NOTE:** To ensure proper gripping of the cutter bit shank and minimize run-out, the shank of the cutter bit must be inserted into the collet/nut at least 5/8 inch.

7. With the cutter bit inserted and the spindle lock button pressed in to engage the shaft, place the wrench on the collet/nut and turn it clockwise until the collet/nut is firmly tightened on the cutter bit.

**⚠ WARNING:** Tighten the collet/nut securely to prevent the cutter bit from slipping. If the collet/nut is not securely tightened, the cutter bit may detach during use, causing serious personal injury.

**CAUTION:** To prevent damage to the tool, do not tighten the collet/nut without a cutter bit installed.

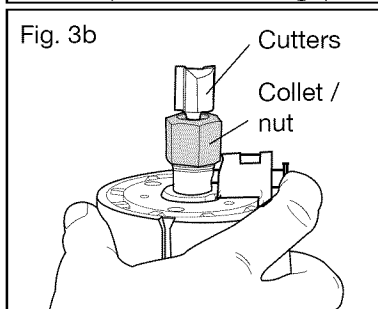
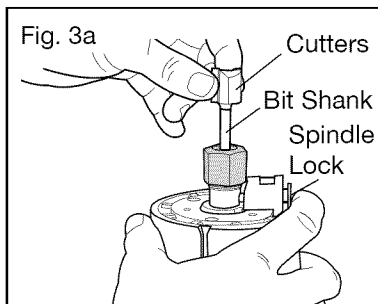

## REMOVING THE CUTTER BIT FROM FIXED BASE

1. Turn the motor off and unplug the router from the power source.

**NOTE:** See the instructions for removing the motor housing from the fixed base.

2. Remove the motor from the fixed base.
3. Set the motor upside down on its top cap, with the collet/nut pointing up.
4. Press the spindle-lock button to engage and lock the spindle shaft and the collet/nut (Fig. 3).
5. Place the wrench on the collet/nut and turn it counter-clockwise to loosen the collet/nut slightly.
6. Remove the cutter bit shank.

## INSTALLING THE CUTTER BIT FOR PLUNGE BASE

1. Turn the motor off and unplug the router from the power source.
2. Remove the motor housing from the plunge base.

**NOTE:** See the instructions for removing the motor housing from the plunge base.

3. Place the router motor upside down on its top cap with the collet/nut pointing up.
4. Press the spindle-lock button to engage and lock the spindle shaft and collet/nut (Fig. 3).



5. Place the wrench on the collet/nut, and turn it counter-clockwise to loosen collet/nut slightly to accept the cutter bit shank.
6. Insert the cutter bit shank into the collet/nut assembly as far as it will go, then back the shank out until the cutters are approximately 1/8 to 1/4 inch away from the face of the collet/nut (Fig. 3a).

**NOTE:** To ensue proper gripping of cutter bit shank and minimize run-out, the shank of the cutter bit must be inserted into the collet/nut at least 5/8 inch.

7. With the cutter bit inserted and the spindle-lock button pressed in to engage the shaft, place the wrench on the collet/nut and turn it clockwise until the router cutter bit and the collet/nut are firmly tightened.

**⚠ WARNING:** Tighten the collet/nut securely to prevent the cutter bit from slipping. If the collet/nut is not securely tightened, the cutter bit may detach during use, causing serious personal injury.

**CAUTION:** To prevent damage to the tool, do not tighten the collet/nut without a cutter bit installed.

## REMOVING THE CUTTER BIT FROM PLUNGE BASE

1. Turn the router motor off and unplug the router from the power source.
2. Remove the router motor from the base.
3. Place the router motor upside down on its top cap, with the collet/nut pointing up.
4. Press the spindle-lock button to engage and lock the spindle shaft and the collet/nut (Fig.6).
5. Place the wrench on the collet/nut and turn it counterclockwise to slightly loosen collet/nut.
6. Remove the cutter-bit shank (Fig. 6a).

**NOTE:** The collet/nut is self-releasing; it is not necessary to strike the collet/nut to free the router cutting bit. If the cutting bit seems stuck after use, loosen the collet/nut a little more until it releases.

## COLLET/NUT CARE

From time to time, inspect the collet/nut to make sure that it is clean and that it is gripping the cutter bit properly.

With the router cutter bit removed, engage the spindle-lock and turn the collet/nut counter-clockwise until it is free from the motor spindle shaft.

Blow the collet out with compressed air, and clean the tapered inside of the collet/nut with a tissue or a fine brush.

Always make sure that the cutter bit shank, collet/nut and motor spindle are clean and free of woodchips, dust, residue, grease and rust before installing.

Apply a small amount of machine oil to the spindle shaft if it looks dry.

Replace worn or damaged collets/nuts immediately.

**NOTE:** The collet/nut is self-releasing; it is not necessary to strike the collet/nut to free the router cutter bit. If cutter bit seems to be stuck after use, loosen the collet/nut a little more until it release.

## CUTTER BITS

Get faster, more accurate cutting results by keeping cutter bits clean and sharp. Remove all accumulated pitch and gum from cutter bits after each use.

When sharpening cutter bits, sharpen only the inside of the cutting edge. Never grind the outside diameter. Be sure, when sharpening the end of a cutter bit, to grind the clearance angle the same as was originally ground.

## INSTALLING THE ROUTER MOTOR IN THE BASES

**⚠ WARNING:** Never use the router motor without installing it into either an approved fixed or plunge base. Failure to do so could result in serious personal injury and damage to motor.

**NOTE:** Before installing the motor housing in the fixed base, have the collet/nut and router cutter bit you are going to use already installed in motor housing. See “INSTALLING AND REMOVING THE CUTTER BIT”.

**⚠ WARNING:** Always turn the motor off and unplug the router from the power source before making any adjustments or installing accessories. Failure to turn the motor off and unplug the router could result in accidental starting, which can cause serious personal injury.

### To Install Motor in Fixed Base (Fig. 4)

1. Turn router motor off and unplug from power source.
2. Place fixed base on flat surface.
3. With back of fixed base facing you, open the motor clamp (A).
4. Press in Coarse Adjustment Knob (B) while you align the motor slot (C) with the pin (D) in the fixed base.
5. When the motor slot is aligned and engaged into the base's pin, slide the motor down into the fixed base.
6. The router motor will now slide up or down to set coarse adjustments when the coarse adjustment knob is pressed in.
7. After all adjustments are made, close the router clamp securely.

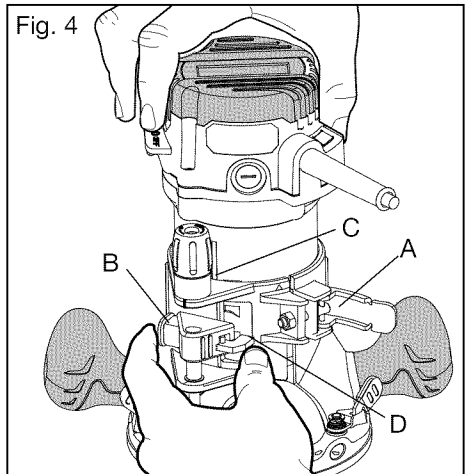

### To Install Motor in Plunge Base (Fig. 5)

1. Turn the motor off and unplug the router from the power source.
2. Place the plunge base on a flat surface.
3. With the back of the plunge base facing you, open the motor clamp (A) and make sure that the plunge action is in the “UP” position with the plunge lock lever (B) locked.

4. With the motor housing slot (C) aligned with the plunge base pin (D), lower the motor housing into the plunge base, engaging the pin into the slot.
5. Slide the motor into the base as far as it will go.
6. Close the motor clamp securely.

## REMOVING THE MOTOR FROM THE BASES

### To Remove the Motor from the Fixed Base (see Fig. 4)

1. Turn router motor off and unplug from power source.
2. Place router (fixed base/router motor) on flat surface.
3. With back of router facing you, open the router motor clamp (A).
4. Push in coarse adjustment knob (B) to release router motor “slot” (C) from pin (D) in base, while you lift router motor free of base.
5. Set motor upside down on its top cap with collet pointing up and remove cutting bit. Store motor and base in carry bag when not being used.

### To Remove the Motor from the Plunge Base (see Fig. 5)

1. Turn the motor off and unplug the router from the power source.
2. Place the router (plunge base and motor housing) on a flat surface.
3. With the back of the plunge base facing you, open the motor clamp (A) and make sure that the plunge action is in the “UP” position with the plunge lock lever (B) locked.
4. Lift the motor straight up out of the base, sliding the motor housing “slot” (C) free from the pin in the plunge base.
5. Set the motor upside down on its top cap with the collet pointing up and remove the bit.

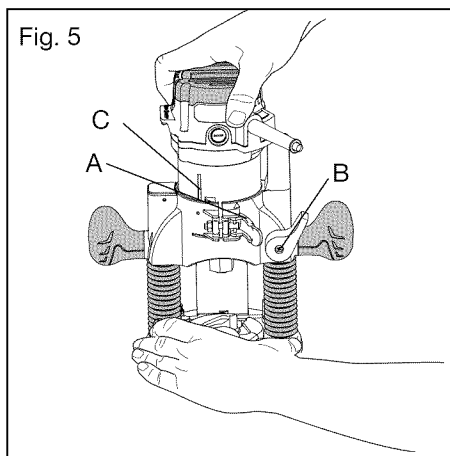

**⚠ WARNING:** Always remove the cutter bits from collet/nut when the router is not being used. Leaving bits installed could result in an accidents causing serious personal injury.

## ADJUSTING THE DEPTH OF CUT

**⚠ WARNING:** Your router should never be turned on or be connected to the power source when you are assembling parts, making adjustments, installing or removing collets/nuts and cutter bits, cleaning or when it is not in use. Disconnecting the router will prevent accidental starting, which could cause serious personal injury.

## DEPTH ADJUSTMENT WITH FIXED BASE (Figs. 6 and 7)

**NOTE:** All depth adjustments on the fixed base must be made with the motor clamp open.

**NOTE:** For all fixed base routers, the cutter bit depth equals the amount of the cutter that is exposed below the surface of the sub-base.

The fixed base is designed with a micrometer-fine adjustment system. When the bit is lowered to the approximate position desired (coarse setting), the system can then be micro-adjusted to the precise depth.

### Coarse Adjustment:

Depressing the coarse adjustment knob (B) allows you to quickly lower or raise the cutter bit to an approximate depth setting.

### Fine Adjustments:

**NOTE:** Be sure that the worm gear system is engaged before making fine adjustments. Test it by turning the Fine Adjustment Dial (C) clockwise and counter-clockwise to see if the bit lowers and raises. If it does not, press in the Coarse Adjustment Knob and turn the Fine Adjustment Dial until the gears engage, then reset zero "0" on Depth Indicator Ring (D).

The Depth Indicator Ring (D) located on the Fine Adjustment Dial is marked in 1/64-inch increments. Turning the fine adjustment dial clockwise 180° (1/2 turn), lowers the cutter bit 1/16 inch. One full turn clockwise 360° (zero "0" to zero "0") lowers the bit 1/8 inch.

The Depth Indicator Ring (D) located on the Fine Adjustment Dial is marked in 1/64-inch increments. Turning the fine adjustment dial clockwise 180° (1/2 turn), lowers the cutter bit 1/16 inch. One full turn clockwise 360° (zero "0" to zero "0") lowers the bit 1/8 inch.

The system allows a maximum of 7 full 360° revolutions clockwise, to lower the cutter bit a total of 7/8 inch.

The Depth Indicator Ring may be reset to zero "0" without moving the fine adjustment dial. This allows the user to begin adjustments from any reference point desired

### To Adjust Depth (Figs. 6 and 7)

1. Turn the motor off and unplug the router from the power source.
2. Place the router on a flat, level surface with the back of fixed base facing you. Open the Motor Clamp (A).

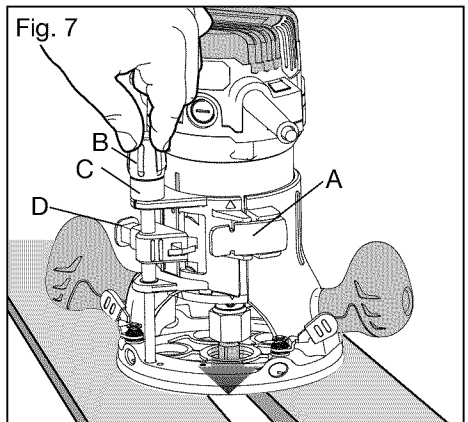
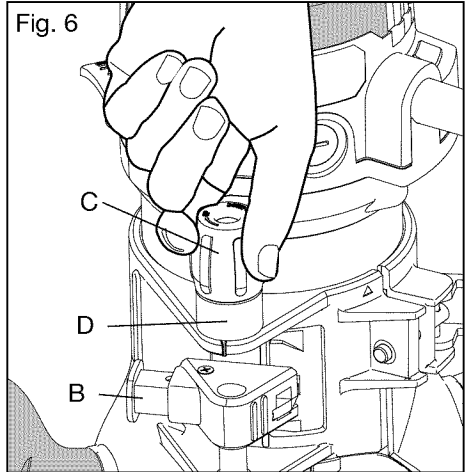

3. With the cutter bit already installed, press in the Coarse Adjustment Knob (B) and lower the motor into the base until the cutter bit is very close to the flat surface on which the base is sitting. Turn the Fine Adjustment Dial (C) until the cutter bit “just” touches the flat surface on which the base is sitting. Then lock the Motor Clamp (A).
4. While continuing to press the Coarse Adjustment Knob (B), turn the Fine Adjustment Dial (C) until the zero “0” mark on the Depth Indicator Ring (D) is lined up with the “1” mark on the base.
5. Release the Coarse Adjustment Knob(B), making sure that the “0” stays lined up with the mark.
6. Place the router on two level scrap workpieces, positioned so that the cutter bit can be lowered below the sub-base (see Fig. 7).
7. Turn the Fine Adjustment Dial (C) clockwise to lower the bit to the desired depth of cut. Turn the dial counterclockwise to raise the cutter bit.
8. Once your depth of cut is set, close the motor clamp (A) securely.

**NOTE:** Making a single deep cut is never advisable. Smaller diameter cutter bits are easily broken by too much side thrust and torque. Larger cutter bits will cause a rough cut and be difficult to guide and control. For these reasons, do not exceed 1/8-in. depth of cut in a single pass.

### **Deep Cuts**

The proper cutting depth (for each pass), is always determined by the material, the cutter bit size and type, and the power of the motor.

Always make several progressively deeper cuts by starting at one depth and then making several passes, each time increasing the cutting depth until your desired depth is reached.

Making a cut that is too deep will stress the motor and the cutter bit, and it may burn the workpiece and dull the cutter bit. It could also “grab” too much of the workpiece and cause you to lose control of the router, causing a serious accident.

To be certain that your depth settings are correct, always make test cuts in scrap material similar to your workpiece before beginning your final cutting.

Remember, knowing the right depth for each cut comes with routing experience.

### **DEPTH ADJUSTMENT WITH THE PLUNGE BASE**

 **WARNING:** Your router should never be turned on or be connected to the power source when you are assembling parts, making adjustments, installing or removing collets/nuts or cutter bits, cleaning or when it is not in use. Disconnecting the router will prevent accidental starting, which could cause serious personal injury.

## PLUNGING ACTION (Fig. 8)

The plunge base feature simplifies the depth adjustments and allows the cutter bit to be accurately lowered down into the workpiece for more precise set-ups.

To lower the cutter bit, release the plunge-lock lever by moving it “Up” to the unlocked position.

Apply an even downward pressure on the plunge action until the cutter bit reaches the desired depth, then move the plunge-lock lever “Down” to the locked position.

To raise the bit and the plunge action, unlock the plunge-lock lever and the cutter bit and the plunge action will automatically retract from the workpiece and return to the raised position.

Always have the plunge action in the raised position and locked when the bit is not cutting in the workpiece.

## PLUNGE ACTION WITH DEPTH-STOP ROD AND DEPTH-STOP TURRET (Fig. 9)

The Depth-Stop Rod and the Depth-Stop Turret are used to control the plunge action cutting depth as follows:

1. Turn the motor off and unplug the router from the power source.
2. Place the router on a flat, level surface.
3. With the cutting bit already installed, lower the plunge action until the cutter bit makes contact with the flat, level surface on which the router is sitting. Lock the plunge-depth locking lever (F). This position is zero “0”: the point from which further depth adjustments can be made.
4. To set a desired depth-of-cut, rotate the depth-stop turret until the lowest step of the turret (A) is aligned directly under the depth-stop rod (B) (see Fig. 9). Loosen the depth-rod locking knob (C) and lower the depth-stop rod until it contacts the lowest step on the turret.
5. Slide the clear plastic depth indicator (D) until the red line on the indicator is lined up with ZERO - “0” marked in black on the bottom of the depth scale. (This is now the indicating point at which the bit makes contact with the workpiece).

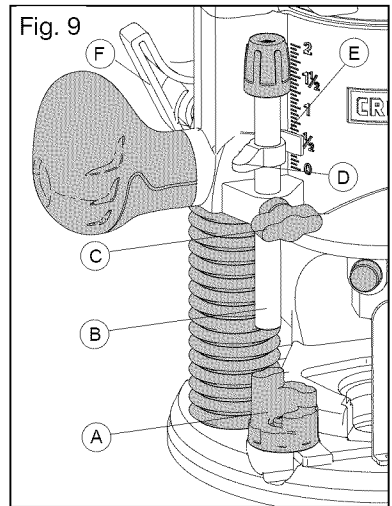
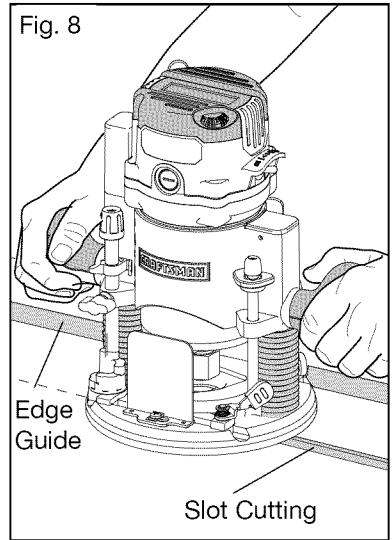

6. To set a desired cutting depth, slide the depth-stop rod up until the red line on the clear plastic depth indicator points to your desired cutting depth on the depth scale (E). Secure the depth-stop rod at this position by tightening the depth-rod locking knob (C).
7. Unlock the plunge depth locking lever (F) to allow the bit to automatically retract to the up position.
8. The desired depth-of-cut may now be achieved by plunging the router down until the depth-stop rod contacts the selected step on the depth-stop turret.

**NOTE:** When making depth adjustments on the plunge base, the motor clamp should always be closed securely.

### Using the Depth-Stop Turret to Set Up Deep Cuts (Fig. 10)

**NOTE:** Making a single deep cut is never advisable. Smaller diameter cutter bits are easily broken by too much side thrust and torque. Larger cutter bits will cause a rough cut and be difficult to guide and control. For these reasons, do not exceed 1/8-in. depth of cut in a single pass.

To produce deep cuts, always make several progressively deeper cuts by starting with the highest step on the depth-stop turret, and, after each cut, rotate the turret to the next lower step until the lowest step is reached.

Each of the steps progresses by 1/4 inch increments. The 4 steps represent a total of "0" inch to 3/4-inch with a full 360° rotation of the turret. Repeat this process if necessary.

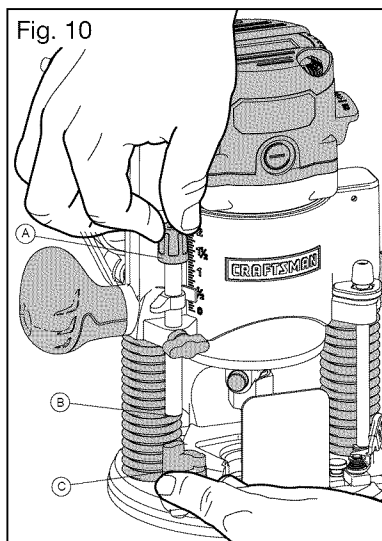

### Micro-adjustments with the Depth-Stop Rod and Depth-Stop Turret

The depth-stop rod has a micro-adjustment knob (A) that turns a screw (B) (inside the rod) either clockwise or counterclockwise to lower or raise the depth-stop rod on the turret (C) for micro-fine adjustments of the plunge depth.

Each complete revolution of the Micro-adjustment knob adjusts the plunging depth by approximately 1/32 inch.

A reference indicator line is embossed into the Depth-Stop Rod under the fine-adjustment knob to set a reference point of "0".

When micro-adjusting the plunge depth, always make sure that the micro-adjustment knob has been turned down (clockwise) several revolutions from the top before setting the Depth-Stop Rod and Depth-Stop turret.

Always set your micro-adjustments with the plunge action locked in the raised, (or up) position.

To use the micro-adjustment knob after the depth rod and turret have been set, check the final depth setting and micro-adjust as follows:

- To micro-increase the plunge depth, raise the micro-adjustment screw by turning the knob counterclockwise the desired amount.
- To micro-reduce the plunge depth, lower the micro-adjustment screw by turning the knob clockwise the desired amount.

### **TOGGLE “ON/OFF” SWITCH (Fig. 11)**

Your router motor is turned “ON” and “OFF” with the toggle switch located on the top cap of the motor housing.

The left side of the toggle switch hood (as you face it) is marked “I” for “ON” and the right side (as you face it) is marked “O” for “OFF.”

To turn the motor “ON”, push the toggle switch to the left side marked “I” or “ON.”

To turn the motor “OFF” push the toggle switch to the right side marked “O” or “OFF.”

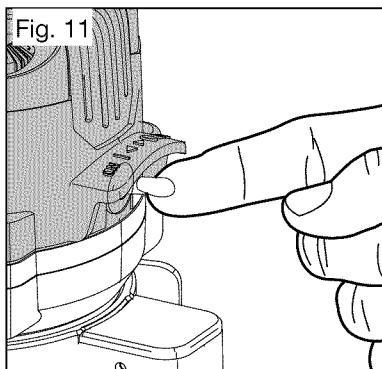

Always hold the router and the cutter bit away from the workpiece when turning the toggle switch “On.” Only contact the workpiece with the router and cutter bit after the router has reached the full selected speed. Only remove the router and cutter bit from the workpiece after turning the router motor “OFF” and after the cutter bit comes to a complete stop.

### **SOFT START FEATURE**

The soft start control minimizes torque twist, customary in larger router motors, by limiting the speed at which the motor starts. This increases the motor’s life.

### **LED WORKLIGHTS (Fig. 12)**

Your router motor has 3 built-in worklights located around the collet/nut to provide high visibility of workpiece when cutting. These lights are always “On” when the toggle switch is in the “ON” position.

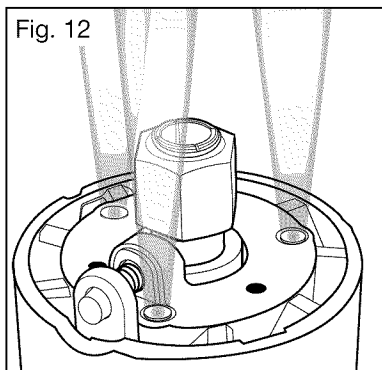



## “LIVE TOOL INDICATOR” LIGHT (Fig. 13)

Your router also has a “Live Tool Indicator” green light, located on the motor housing top cap where the power cord enters the motor housing. This green light is always on when the router motor is plugged into a power source.

## HEAVY-DUTY EDGE GUIDE

The router combo kit comes with a heavy duty edge guide. This edge guide can be used as an aid in routing applications such as decorative edging, straight edge planning and trimming, grooving, dadoing and slotting.

To attach the edge guide to the fixed or plunge base, simply insert the edge guide mounting rods into the edge-guide mounting slots either from the left or the right.

For fix base Tighten the lever on the left by turning it clockwise to secure the edge guide rod (Fig.14). Tighten the lever on right by turning counterclockwise to secure the rod (Fig.14).

For plunge base Tighten the lever on the left by turning it counterclockwise to secure the edge guide rod (Fig.14a). Tighten the lever on right by turning clockwise to secure the rod (Fig.14a).

**NOTICE:** If the edge guide lever inner screws wear down or require calibration:

- Pull the lever up and turn it clockwise and then push the lever down (Fig.15).
- Turn the lever counterclockwise to secure the edge guide.

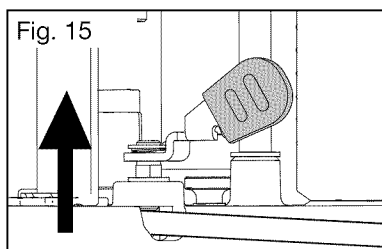
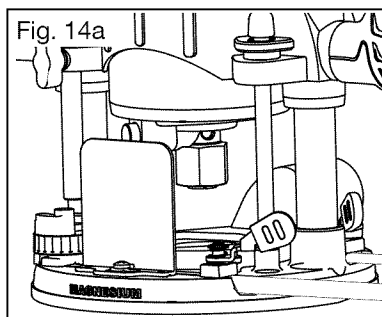
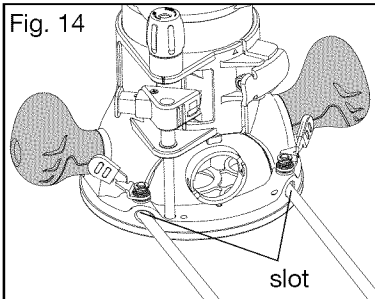
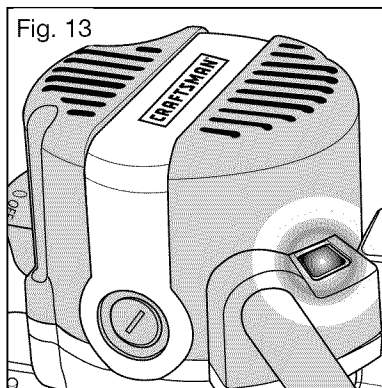

## ELECTRONIC VARIABLE SPEED CONTROL (Fig. 16)

The electronic speed control feature allows motor speed to be matched to cutter size and material for an improved finish and extended bit life.

Speed changes are made starting at “1” and rotating the Speed Control Dial to the “LEFT” to increase the speed, and to the “RIGHT” to decrease the speed as indicated on the Dial, numbered 1 through 6.

**NOTE:** The speed may be changed while the router is “ON”, but not if the cutter bit is in the workpiece.

Your router motor top cap has a “Variable Speed Selection Chart,” located above the “ON/OFF” toggle switch, to help you determine the correct speed for the cutter bit being used.

**▲ WARNING:** Before operating your router, follow all safety instructions in this manual. Failure to do so could result in serious personal injury.

**NOTE:** Choose the applicable cutting speed according the bit diameter and the material being cut.

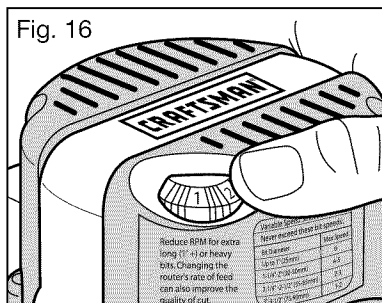

Variable Speed Selection Chart	
Never exceed these bit speeds	
Cutting-Bit Diameter	Speed
UP to 1 in. (.25mm)	6
1-1/4 in. to 2 in. (30-50mm)	4-5
2-1/4 in. to 2-1/2 in. (55-65 mm)	2-3
3 in. to 3-1/2 in. (75-90mm)	1-2

Reduce the speed when using extra large bits (with a cutting diameter 1 inch or greater) or heavy cutting bits. Changing the rate of feed can also improve the quality of the cut.

DIAL SETTING	RPM	APPLICATION
1	10,000	Non-ferrous metal, hardwoods, larger diameter cutter bits
2	13,000	
3	16,000	
4	19,000	Softwoods, plastics, countertops, smaller diameter cutter bits
5	22,000	
6	25,000	

The speed charts on the preceding page indicate the relationship between the speed setting and the cutting application. Exact settings are determined through operator experience and preference, and also by recommendations by manufacturers of cutter bits.

## **ELECTRONIC FEEDBACK CIRCUITRY**

The router electronic feedback circuitry monitors and adjusts power to maintain the desired speed for consistent performance and control, providing constant speed under load for a high-quality finish in all materials.

## **PLACING THE ROUTER ONTO THE WORKPIECE AND STARTING THE CUT**

**NOTE:** Making test cuts is essential with most routing applications. A test cut will give a feel for the set-up, the router's speed, the depth of cut, and how the cutting bit reacts to the workpiece.

Much of routing is a trial-and-error process of making various adjustments, followed by test cuts. To avoid ruining good material, make test cuts on scrap materials.

How you place your router onto a workpiece (starting the cut) with a fixed base or a plunge base depends on the type of routing you are going to produce: Edge Routing or Internal Routing, as discussed on the following pages.

## **DEEP CUTS**

The proper cutting depth for each pass is always determined by the material, the cutter bit size and type, and power of the motor.

Always make several progressively deeper cuts: start at one depth and then make several passes, each time increasing the cutting depth, until your desired depth is reached.

Making a cut that is too deep will stress the router motor and the cutter bit, and it may burn the workpiece and dull the cutter bit. It could also “grab” too much of the workpiece and cause you to lose of control of the router, causing a serious accident.

To be certain that your depth settings are correct, always make test cuts in scrap material similar to your workpiece before beginning the final cutting operation.

Remember, knowing the right depth for each cut comes with routing experience.

## **EDGE ROUTING OR INTERNAL ROUTING**

For ease of operation and to maintain proper control, your router has two handles, one on each side of the router base. When operating the router, always hold it firmly with both hands (Fig. 17 and 17a).

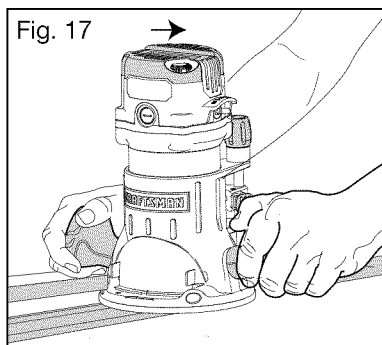

Fig. 17

## EDGE ROUTING (Figs. 17 and 17a)

1. With the depth-of-cut set, place the router on the edge of workpiece, making sure that the cutter does not contact the workpiece. (With the plunge base, lock the plunge action in the DOWN position, ready to cut).
2. Have an edge guide (or a board or a metal straightedge) clamped in place to help guide router base when making the edge cut.
3. Turn the router "ON," and allow the router motor to reach the selected speed.
4. To begin the cut, gradually feed the cutter into the edge of the workpiece.
5. When the cut is complete, turn router motor "OFF" and allow the cutter bit come to a complete stop before removing it from the workpiece.
6. Unplug the router from the power source, and inspect the finished cut.

**⚠ WARNING:** Always securely clamp your workpiece and keep a firm grip on the router base with both hands at all times. Failure to do so could result in loss of control causing possible serious personal injury.

**⚠ WARNING:** Removing the cutter bit from the workpiece while it is still rotating could damage the workpiece and result in loss of control, causing serious personal injury.

## INTERNAL ROUTING WITH FIXED BASE (Figs. 18, 18a, 18b and 19)

1. With the depth-of-cut set, tilt the router and place it on the workpiece with the leading edge of the sub-base contacting the workpiece first (Fig. 18).
2. Turn the router motor "ON" and allow the router motor to reach the selected speed, being careful not to allow the cutter bit to contact the workpiece.
3. To begin your cut, gradually lower the cutter bit into the workpiece until the sub-base is flush with the workpiece (see Fig 18a and 18b).

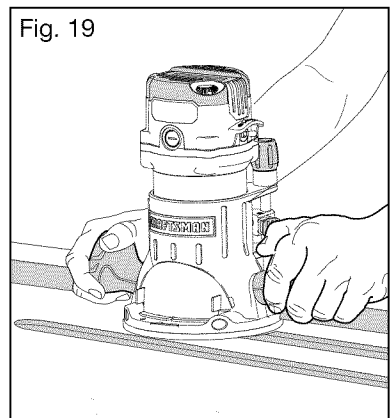
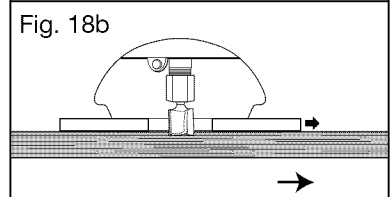
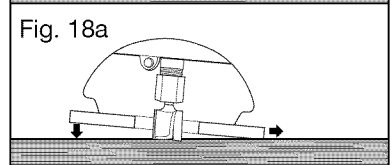
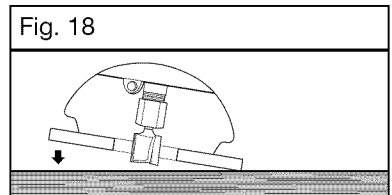
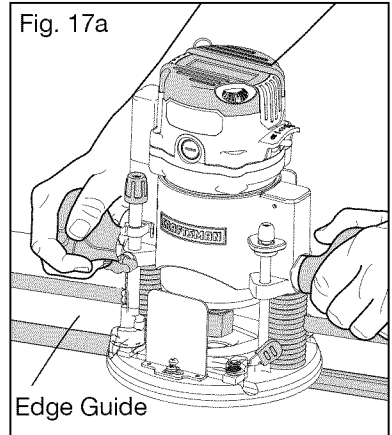

4. When the cut is complete, turn the router motor “OFF” and allow the cutter bit come to a complete stop before removing it from the workpiece.
5. Unplug the router from power source, place the router upside down on the worktable, and inspect the finished cut in the workpiece.

**⚠ WARNING:** Always securely clamp your workpiece and keep a firm grip on the router base with both hands at all times. Failure to do so could result in loss of control causing possible serious personal injury. If using a router table, large cutter bits should be used for edging only.

**⚠ WARNING:** Removing the cutter bit from workpiece while it is still rotating could damage the workpiece and result in loss of control, causing serious personal injury.

### INTERNAL ROUTING WITH PLUNGE BASE (Figs. 20 and 20a)

1. With the depth-of-cut set, and the plunge action locked in the raised (Up) position, turn the motor “ON” and let the motor build up to its full selected speed (see Fig. 20).
2. To begin your cut, unlock the plunge-lock lever and gently lower the plunge action evenly into the workpiece.
3. When the desired depth-of-cut is achieved, lock the plunge-lock lever (Down) and proceed to make your cut.
4. When the cut is completed, turn the motor “OFF” and let the cutter bit come to a complete stop.
5. When the cutter bit comes to a complete stop, unlock the plunge-lock lever (Up) and the plunge action will automatically retract the cutter bit from workpiece.

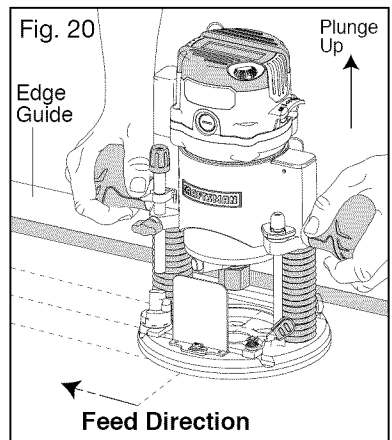

- ⚠ WARNING:** Removing the cutter bit from workpiece while it is still rotating could damage the workpiece and result in loss of control, causing serious personal injury.
6. Unplug the router from the power source, place the router on worktable, and inspect the finished cut in the workpiece.

**⚠ WARNING:** Always securely clamp the workpiece in place, and keep a firm grip on the router base with both hands at all times. Failure to do so could result in loss of control, causing serious personal injury.

## FREEHAND ROUTING WITH THE FIXED BASE (Fig. 21)

**▲ WARNING:** Do not use large cutter bits for freehand routing. Using large cutter bits when freehand routing could cause loss of control or create other hazardous conditions that could result in personal injury. If using a router table, large bits should be used for edging only.

When used freehand, the router becomes a flexible and versatile tool. This flexibility makes it possible to easily rout signs, relief sculptures, etc.

When freehand routing:

1. Draw or lay out the pattern on the workpiece.
2. Choose the appropriate bit.
3. Follow the instructions for INTERNAL ROUTING, and rout the pattern in two or more passes. Do not exceed 1/8-in. depth of cut in a single pass. This will help provide better control, as well as serve as a guide on the next passes.

**NOTE:** A core-box bit or V-groove bit is often used for routing letters and engraving objects. Straight bits and ball mills are often used to make relief carvings. Veining bits are used to carve small, intricate details.

**NOTE:** Making a single deep cut is never advisable. Smaller-diameter bits are easily broken by too much side thrust and torque. Larger bits will cause a rough cut and be difficult to guide and control. For these reasons, do not exceed 1/8-in. depth of cut in a single pass.

**▲ WARNING:** Always securely clamp your workpiece in place, and keep a firm grip on the router base with both hands at all times. Failure to do so could result in loss of control causing possible serious personal injury.

## EDGING WITH A PILOT BIT (Figs. 22 and 22a)

The arbor-type bits with pilots are excellent for edge shaping of any workpiece edge that is either straight or curved at a curvature as great or greater than the radius of the bit to be used. The pilot prevents the bit from making an excessively deep cut; and holding the pilot firmly in contact with the workpiece edge throughout prevents the cut from becoming too shallow.

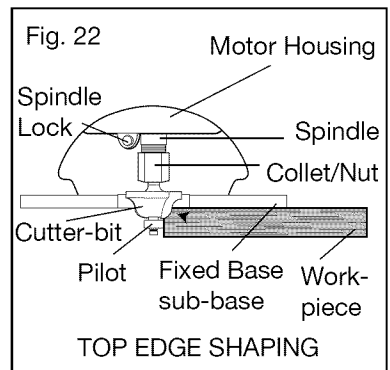
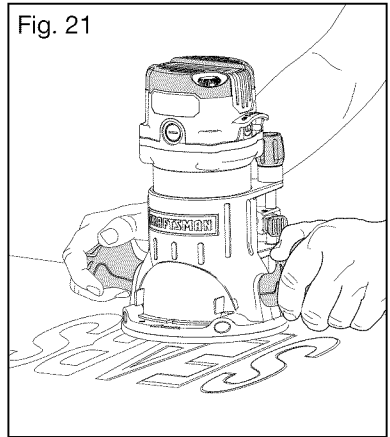

## Top Edge Shaping

Whenever the workpiece thickness, together with the desired depth of cut (as adjusted by router depth setting) are such that only the top part of the edge is to be shaped (leaving at least a 1/16-in. thick uncut portion at the bottom), the pilot can ride against the uncut portion, which serves to guide it (Fig. 22).

## Whole Edge Shaping

If the workpiece is too thin or the bit is set so low that there will be no uncut edge against which to ride the pilot, an extra board must be placed under the workpiece to act as a guide (see Fig. 22a). This “guide” board must have exactly the same contour - straight or curved - as the workpiece edge. If it is positioned so that its edge is flush with the workpiece edge, the bit will make a full cut (in as far as the bit radius). On the other hand, if the guide is positioned so that it extends beyond the edge of the workpiece), the bit will make less than a full cut - which will alter the shape of the finished edge.

**NOTE:** The size (diameter) of the pilot that is used determines the maximum cut width that can be made with the pilot against the workpiece edge (the small pilot exposes the entire bit; the large one reduces this amount by 1/16-in.). Any of the piloted cutter bits can be used without a pilot for edge shaping with guides.

**⚠ WARNING:** Always securely clamp your workpiece and keep a firm grip on the router base with both hands at all times. Failure to do so could result in loss of control causing possible serious personal injury.

## FEEDING THE ROUTER (Fig .23)

The secrets to professional routing are a careful set-up for the cut, selecting the proper depth of cut, knowing how the cutter bit reacts in your workpiece, and the rate and direction of feed of the router.

### DIRECTION OF FEED - EXTERNAL CUTS

The cutter bit rotates clockwise. Feeding the bit from left to right will cause the bit to pull the router towards the workpiece (see Fig. 23). If the router is fed in the opposite direction (right to left), the rotating force of the cutter bit will tend to throw the bit away from the workpiece.

This is called “Climb-Cutting.” “Climb-Cutting” may cause loss of control,

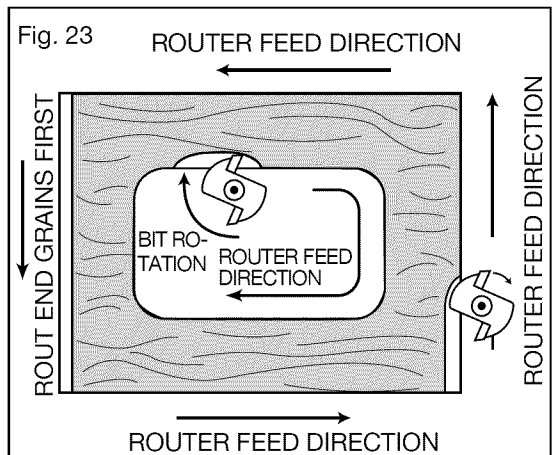
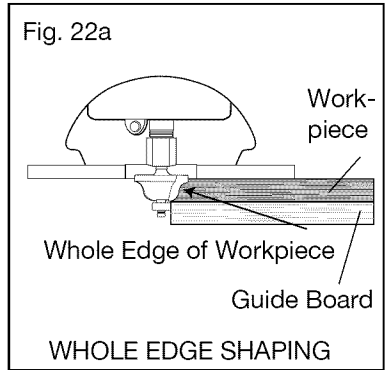

possibly resulting in personal injury. When “Climb-Cutting” is required (e.g., backing around a corner), exercise extreme caution to maintain control of the router. The high speed of the cutter bit during a proper feeding operation (left to right), results in very little kickback under normal conditions. However, if the cutter bit strikes a knot, an area of hard grain, or a foreign object, “Kickback” may result. Kickback may damage your workpiece and could cause you to lose control of the router, possibly causing personal injury. Kickback is always in the opposite direction of the clockwise cutter bit rotation, or counterclockwise.

To guard against and help prevent Kickback, plan your set-up and direction of feed so that you’re always keeping the sharp edges of the cutter bit biting straight into uncut wood . Always inspect your workpiece for knots, hard grain, and foreign objects .

**WARNING:** Kickback causes the power tool to jerk back toward the user, causing possible loss of control and serious injury. Always take precautions against kickback as described in the operator’s manual.

### DIRECTION OF FEED - INTERNAL CUTS (Figs. 24 and 24a)

When making an internal cut, such as a groove, dado, or slot, always try to have the guide you are using with the router (edge guide, straight edge, board guide), on the right-hand side of the router as you make the cut (Fig. 24).

When the guide is positioned on the right hand side of the router, the router travel should be from left to right and “counterclockwise” around curves (see Fig. 24). This counterclockwise action around the curve could cause “Climb cutting”. Always be alert and exercise extreme caution to maintain control of the router when making this type of cut around curves.

When the guide is positioned as shown in Fig. 24a, the router travel should be from left to right and clockwise around curves.

If there is a choice, the set-up in Fig. 24 is easier to use, but there is the possibility of “Climb Cutting” around curves. In either case, Fig. 24 or Fig. 24a, the sideways thrust of the router cutting is always against the guide, as is proper.

**⚠ WARNING:** Always securely clamp the workpiece in place, and keep a firm grip on the router base with both hands at all times. Failure to do so could result in loss of control causing possible serious personal injury.

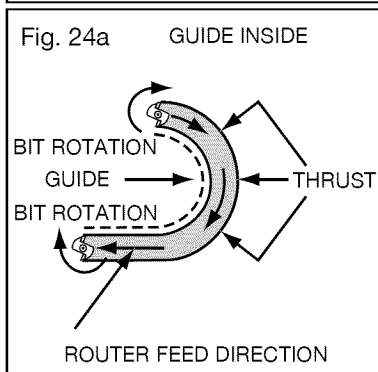
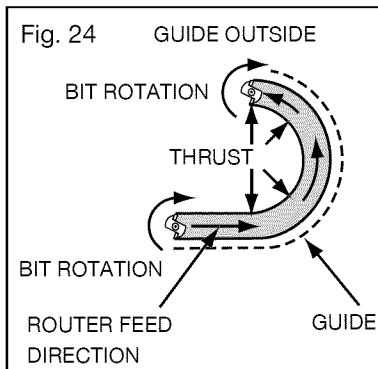



## RATE OF FEED (Figs. 25 and 25a)

The proper rate of feed depends on several factors: the hardness and moisture content of the workpiece, the depth of cut, and the cutting diameter of the bit. When cutting shallow grooves in soft woods such as pine, you may use a faster rate of feed. When making deep cuts in hardwoods such as oak, you should use a slower rate of feed.

### FEEDING TOO QUICKLY (Fig. 25)

Clean and smooth cuts can only be achieved when the cutter bit is rotating at a relatively high speed, taking very small bites, producing tiny, clean-cut chips.

Forcing the feed of the cutter bit forward too quickly slows the rotational speed of the cutter bit, and the bit takes bigger bites as it rotates. Bigger bites cause bigger chips and a rough finish. This forcing action can also cause the router motor to overheat.

Under extreme force-feeding conditions, the speed can become so slow and the bites become so large that chips become partially cut off, causing splintering and gouging of the workpiece.

The router will make clean, smooth cuts if allowed to run freely without the overload of forced feeding. You can detect forced feeding by the sound of the motor. Its usual high-pitched whine will sound lower and stronger as it loses speed. Holding the router against the workpiece will also be strained and harder to do.

### FEEDING TOO SLOWLY (Fig. 25a)

When you feed the cutter bit too slowly, the rotating cutter bit does not cut into new wood rapidly enough to take a bite. Instead, it scrapes away sawdust-like particles. This scraping produces heat, which can glaze, burn, and mar the cut in the workpiece and, in extreme cases, overheat the cutter bit.

When the cutter bit is scraping instead of cutting, the router is more difficult to control as you feed it.

With almost no load on the motor, the cutter bit has a tendency to bounce off the sides of the cut in the workpiece, producing a cut with a rippled finish instead of clean straight sides.

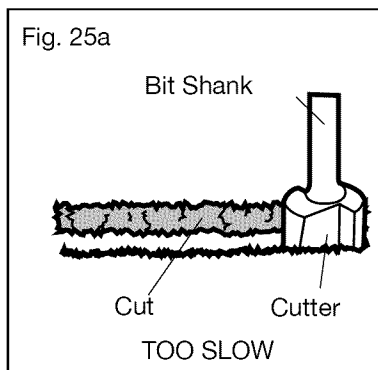
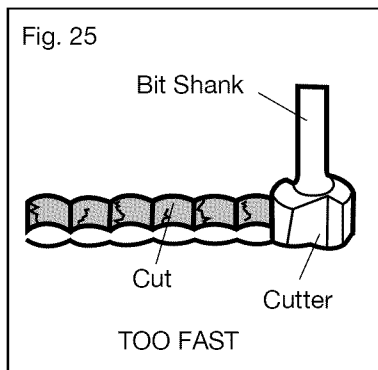

## CHIP SHIELDS (Figs. 26 and 26a)

**▲ WARNING:** Always wear eye protection. The chip shields are not intended as safety guards.

To remove the chip shield from the fixed base, press inward on the tabs until the chip shield releases from the base and then remove the chip shield. To attach, place the chip shield back in position and flex the sides while pushing the shield in until it snaps back in place (Fig. 26).

The chip shield on the plunge base is held in position with a screw. To remove the chip shield from the plunge base, simply loosen the screw and take the chip shield off the base (Fig. 26a).

**▲ WARNING:** The chip shield helps to keep dust and chips away from the operator; they will not stop objects larger than woodchips that may be thrown from the bit.

**▲ WARNING:** Always have the appropriate chip shield in place on the base when operating the router.

**▲ WARNING:** Always turn the router motor off and unplug the router from the power source before making any adjustments or installing accessories. Failure to turn the motor off and unplug the router could result in accidental starting, which can cause serious personal injury.

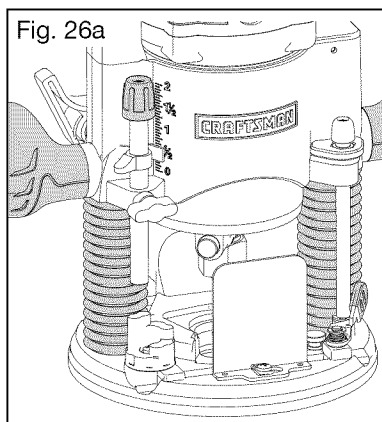
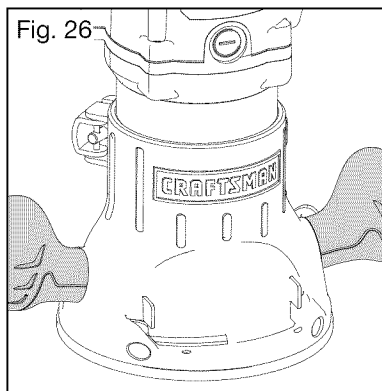

## DUST COLLECTION WITH VACUUM PORT (Figs. 27 and 27a)

Two vacuum ports are included with the router bases. Each adapter is sized to accept a 1-1/4-in. vac hose adapter, sold separately.

### ATTACH THE VACUUM PORT ONTO THE FIXED BASE (Fig. 27)

To attach the vacuum port onto the fixed base, align the two tabs on the port with the two slots on the port at back of the base, and secure it by turning it clockwise (Fig. 27a).

### ATTACH THE VACUUM PORT ONTO THE PLUNGE BASE (Fig. 27a)

To attach the vacuum port onto the plunge base, position and secure it to the back of the base with the two thumb screws (included), as shown in Fig. 27.

### TO ADJUST DEPTH WITH DEPTH-ADJUSTMENT WRENCH (Figs. 28, 28a and 28b)

**NOTE:** The Depth-Adjustment wrench supplied is used to adjust the depth when the router is fixed to the router table (Model No. 320. 28160), sold separately.

**⚠ WARNING:** Always read and follow all directions for mounting the router to a router table and for use of the router table.

**⚠ WARNING:** Always turn the router motor off and unplug the router from the power source before making any adjustments or installing accessories. Failure to turn the router motor off and unplug the router could result in accidental starting, which can cause serious personal injury.

**⚠ WARNING:** Only use router tables with proper guarding for the cutting bit and with “on-board,” switch-controlled receptacles. Failure to use router tables with appropriate safety features could result in serious personal injury.

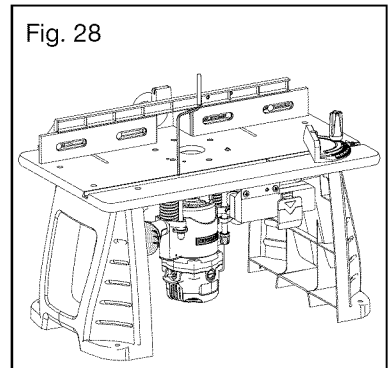
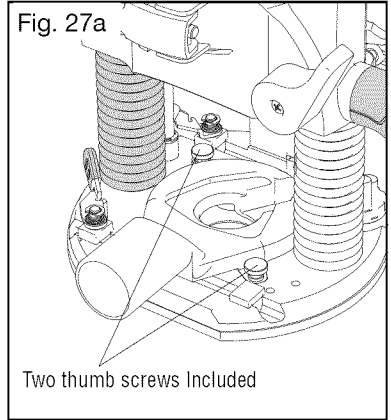
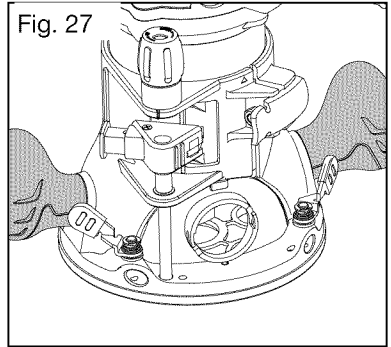

## Fixed Base Router

When using either the fixed base to attach the router to the router table, the bit depth can be adjusted by turning the Micro-adjustment Dial clockwise or counterclockwise with the wrench supplied. (Fig. 28a and Fig. 28b). The depth of the cut can be read on the scale dial. Each mark on the scale indicates a 1/64-in. change in depth setting.

1. Turn off the router.
2. Loosen the router motor clamp.
3. Insert the wrench into the adjusting hole on the tabletop. Turn the adjustment bolt on the router clockwise with the wrench to move the collet/nut up, or counterclockwise to move the collet/nut down.
4. When the desired depth of cut is set, tighten the router motor clamp. The precise depth of cut can be measured with a ruler.

## Plunge Base Router

When using the plunge base to attach the router to the router table, the bit depth can be adjusted by turning the depth rod clockwise or counterclockwise with the wrench supplied (Fig. 28b).

1. Turn off the router.
2. Loosen the router motor clamp.
3. Lock the plunge-depth locking lever.
4. Insert the wrench into the adjusting hole on the tabletop. Turn the depth rod on the router clockwise with the wrench to move the collet/nut up, or counterclockwise to move the collet/nut down.
5. When the desired depth of cut is set, tighten the router motor clamp. The precise depth of cut can be measured with a ruler.

Fig. 28a

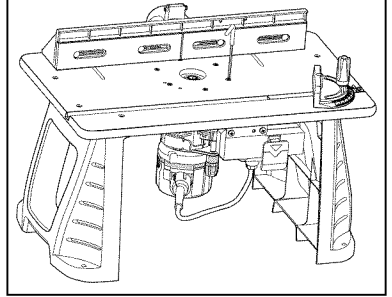
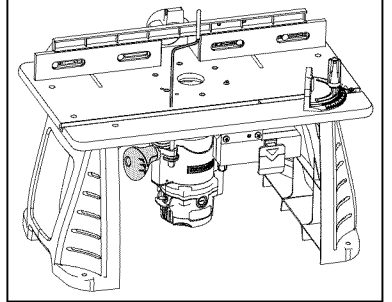

Fig. 28b



## MAINTENANCE

**⚠ WARNING:** To ensure safety and reliability, all repairs should be performed by a qualified service technician at a Sears Service Center.

### GENERAL

Only the parts shown on the parts list are intended for repair or replacement by the customer. All other parts represent an important part of the double-insulation system and should be serviced only by a qualified Craftsman service technician.

**⚠ WARNING:** For your safety, always turn off the switch and unplug the router motor from the power source before performing any maintenance or cleaning.

Electric tools are subject to accelerated wear and possible premature failure when they are used to work on fiberglass boats and sports cars, wallboard, spackling compounds or plaster. The chips and grindings from these materials are highly abrasive to electrical tool parts, such as bearings, brushes, commutators, etc. Consequently, it is not recommended that this tool be used for extended work on any fiberglass material, wallboard, spackling compound, or plaster. During any use on these materials, it is extremely important that the tool is cleaned frequently by blowing with an air jet.

**⚠ WARNING:** Always wear safety goggles or safety glasses with side shields during power tool operations, or when blowing dust. If operation is dusty, also wear a dust mask.

### ROUTINE MAINTENANCE

**⚠ WARNING:** Do not at any time allow brake fluids, gasoline, petroleum-based products, penetrating oils, etc. to come in contact with plastic parts. Chemicals can damage, weaken, or destroy plastic, which may result in serious personal injury.

1. When work has been completed, clean the tool to allow smooth functioning of the tool over time.
2. Use clean, damp cloths to wipe the tool.
3. Check the state of all electrical cables.
4. Keep the motor air openings free from oil, grease, and sawdust or woodchips, and store the tool in a dry place.
5. Be certain that all moving parts are well lubricated with a high quality machine oil, particularly after lengthy exposure to damp and/or dirty conditions.

**⚠ WARNING:** For your safety, always turn off the switch and unplug the router motor from the power source before performing any maintenance or cleaning.

For collet and bit cleaning care, refer to “Collet/Nut Care” and “Cutter Bits” near the beginning of the Operation section of this manual.

## REPLACEMENT OF CARBON BRUSHES (Fig .29)

Replacement brush sets are available through Sears Parts and Repair Centers.

1. Unplug the router motor before inspecting or replacing brushes.
2. Replace both carbon brushes when either has less than 1/4-in. length of carbon remaining, or if the spring or wire is damaged or burned.
3. Using a slotted screwdriver, remove the black, plastic cap on each side of the router motor (Fig. 29) and carefully withdraw the spring-loaded brush assemblies. Keep brushes clean and sliding freely in their guide channels.

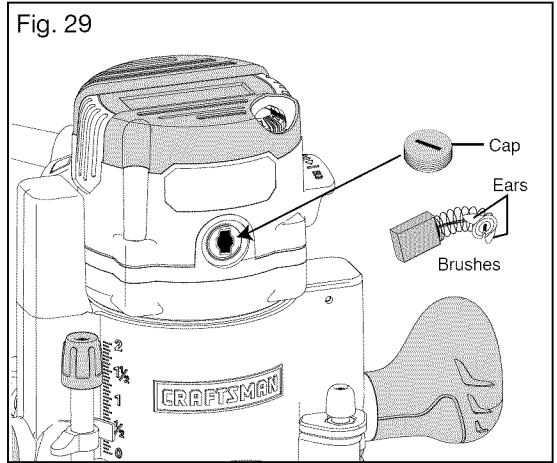

**NOTE:** To reinstall the same brushes, make sure that the brushes go back in the same way they came out. This will avoid the need for a break-in period.

4. Insert new brush assemblies into the guide channels with the carbon part going in first, being certain to fit the two metal “ears” into their slots in the channel (Fig. 29).
5. Remember to replace both end caps after inspecting or servicing brushes. Tighten the caps snugly, but do not over-tighten. The router should be allowed to “run in” (run at no load without a cutter bit) for 5 minutes before use, to seat the new brushes properly.

**⚠ WARNING:** For your safety, always turn off the switch and unplug the router motor from the power source before performing any maintenance or cleaning.

## LUBRICATION

All of the bearings in this tool are lubricated with a sufficient amount of high-grade lubricant for the life of the tool under normal operating conditions. Therefore, no further lubrication is required.

## TROUBLESHOOTING

PROBLEM	CAUSE	SOLUTION
The router does not work	Plug is not plugged into the power source.	Plug the detachable cord into the power source.
	Switch is in "OFF" position.	Pull the switch to "ON" position.
	The carbon brushes have worn out completely.	Remove the brush caps, and replace the old brushes with new ones.
The surface of the workpiece is not smooth after cutting	The bit is dull.	Change to a sharp bit.
	Routing at an inappropriate bit speed	Select an appropriate bit speed.
Bit can not be installed	Bit size is inappropriate for the collet/nut	Use only 1/4-in. diameter bits with the 1/4-in. collet; use only 1/2-in. diameter bits with the 1/2-in. collet.

















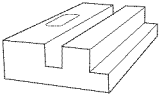

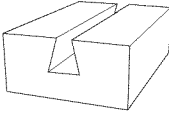

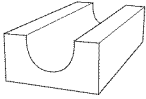

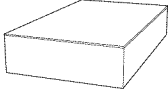

## ACCESSORIES

**⚠ WARNING:** The use of attachments or accessories that are not recommended for this tool might be dangerous and could result in serious injury. Sears and other Craftsman outlets offer a large selection of Craftsman router accessories designed for specific routing applications.

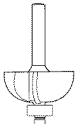

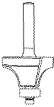



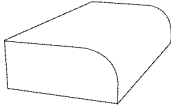

There is a large selection of Craftsman Router Cutting bits available in High-Speed Steel or Carbide Tipped High-Speed Steel for all your routing needs.

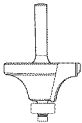
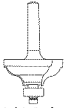
In addition to a wide variety of router bits, Sears also offers accessories such as: Router table (28160), various template sets, universal router fence with lock knobs (64181), 11 pc. bushing set (64180) and clear sub-base sets, 6pc fixed base (64182), 6pc plunge base (64183).

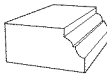
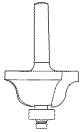
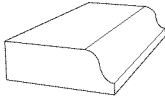
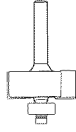
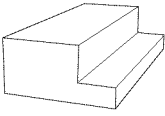
**⚠ WARNING:** Only use router tables with proper guarding for the cutting bit and with "on-board" switch-controlled receptacles. Failure to use router tables with appropriate safety features could result in serious personal injury.

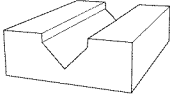
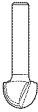
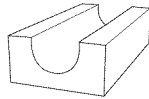
<p>1/8-in. straight</p>  <p>5/16-in. straight</p>  <p>3/8-in. straight</p>  <p>1/2-in. straight</p>  <p>1/4-in. straight</p>  <p>3/4-in. straight</p> 	<p>straight</p> 
<p>3/8-in. dove tail</p>  <p>1/2-in. dove tail</p> 	<p>dovetail</p> 
<p>1/2-in. round nose</p> 	<p>round nose</p> 
<p>1/2-in. 90 d v groove</p> 	<p>v groove</p> 
<p>1/2 x 1-in. flush trim</p>  <p>3/8x1/2-in. flush trim</p>  <p>1/2-in. flush trim</p>  <p>1/4-in. flush trim</p> 	<p>flush trim</p> 
<p>3/8-in. keyhole</p> 	<p>keyhole</p> 
<p>1/2-in. cove</p>  <p>1/4-in. cove</p> 	<p>cove</p> 
<p>3/8-in. round over</p>  <p>1/8-in. round over</p>  <p>1/4-in. round over</p>  <p>1/2-in. round over</p> 	<p>round over</p> 

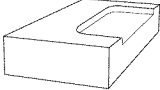

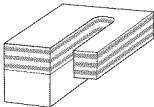
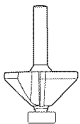
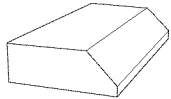
<p>1/2-in. bead and cove</p>  <p>1/16-in. classic cove with bead</p> 	 <p>bead cove</p>  <p>classic cove &amp; bead</p>
<p>1/4-in. roman ogee</p> 	<p>Roman ogee</p> 
<p>3/8-in. rabbeting</p> 	<p>rabbeting</p> 
<p>1/4-in. veining</p> 	<p>veining</p> 
<p>1/2-in. core box</p> 	<p>core box</p> 
<p>1/2-in. mortising</p> 	<p>mortising</p> 
<p>1/4-in. panel pilot</p> 	<p>panel pilot</p> 
<p>1-3/8-in. 45° chamfer</p> 	<p>chamfer</p> 

# PARTS LIST

## 12 Amp Router Model No. 320.27683

The Model Number will be found on the Nameplate attached to the motor unit .  
Always mention the Model Number when ordering parts for this tool.

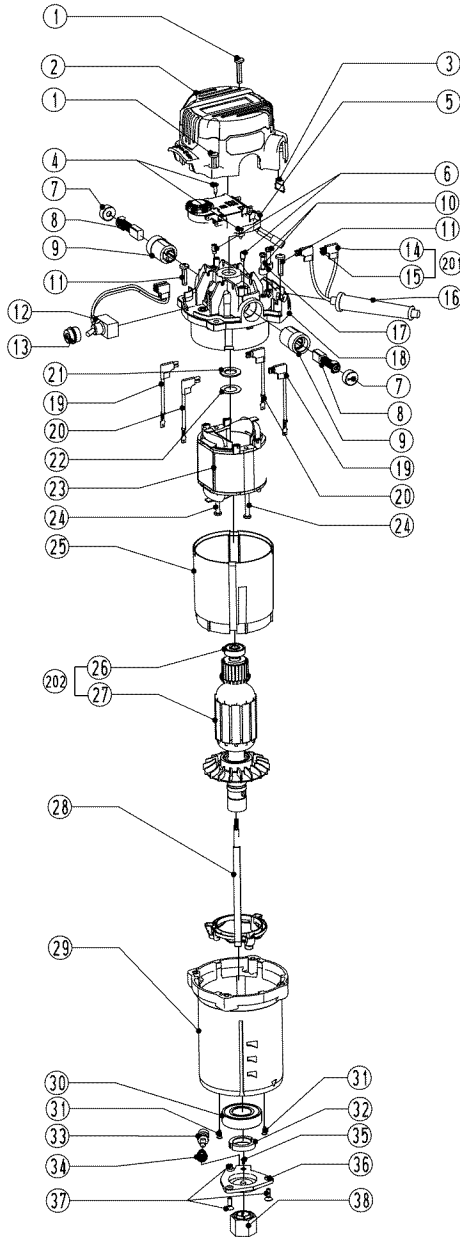

# PARTS LIST

## 12 Amp Router Model No. 320.27683

The Model Number will be found on the Nameplate attached to the motor unit .  
Always mention the Model Number when ordering parts for this tool.

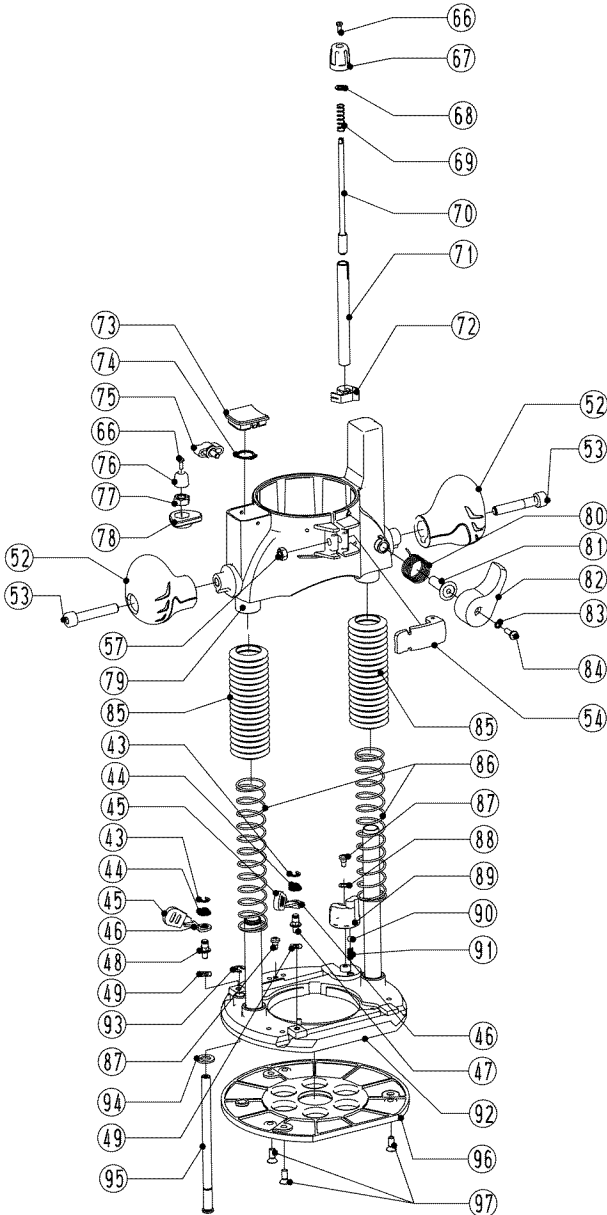

# PARTS LIST

## 12 Amp Router Model No. 320.27683

The Model Number will be found on the Nameplate attached to the motor unit .  
Always mention the Model Number when ordering parts for this tool.

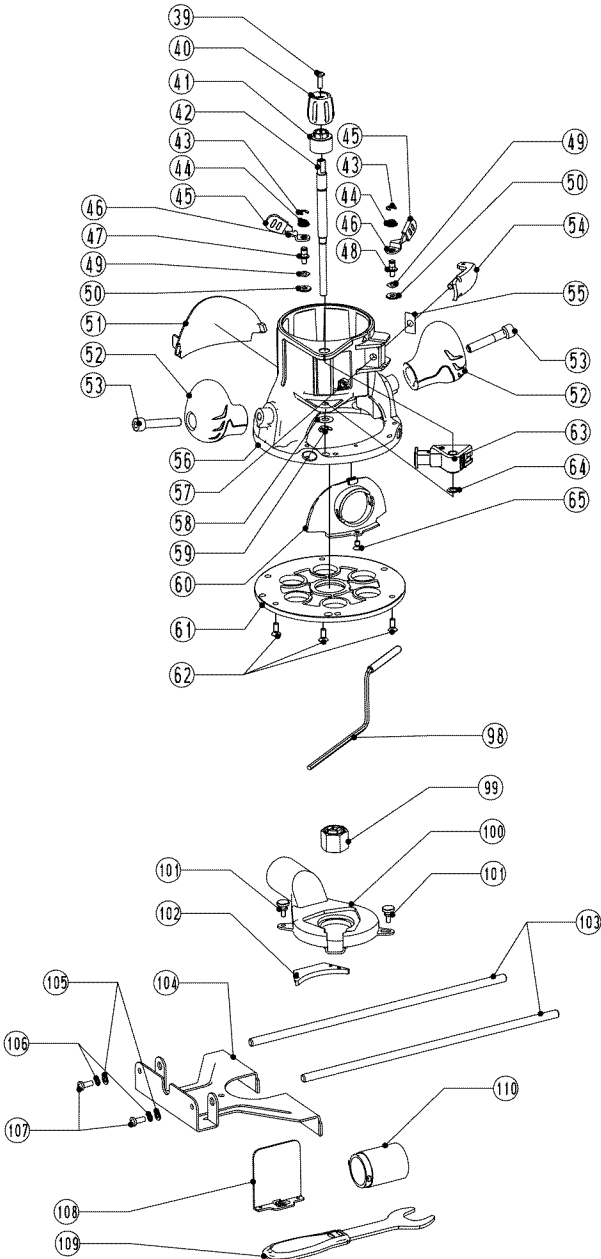

## PARTS LIST

### 12 Amp Router Model No. 320.27683

The Model Number will be found on the Nameplate attached to the motor unit .  
Always mention the Model Number when ordering parts for this tool.

No	Part No	Part Name	QTY
1	5610220000	Screw	2
2	3321133000	Rear Cover	1
3	3121518000	Transparent Cap	1
4	5610017000	Tapping Screw	2
5	4890638000	Speed Adjustor	1
6	5620017000	Screw	2
7	3120537000	Brush Cover	2
8	4960019000	Carbon Brush Assy	2
9	2800005000	Brush Holder Assy	2
10	5610106000	Tapping Screw	2
11	5610059000	Screw	2
12	2823115000	Switch Assy	1
13	3122851000	Seal Ring	1
201	4810002000	Power Cord Assy	1
14	4930008000	Sleeve	2
15	4930038000	Receptacle	2
16	3121064000	Cord Guard	1
17	3122798000	Cord Anchorage	1
18	3125685000	Middle Housing	1
19	2822038000	Inner Wire Assy	2
20	2822039000	Inner Wire Assy	2
21	3121049000	Rubber Spring	1
22	3700249000	Washer	1
23	2740118000	Stator	1
24	5610049000	Tapping Screw	2
25	3125687000	Fan Baffle	1
202	2823131000	Rotor Assy	1
26	5700008000	Ball Bearing	1
27	2750184000	Rotor	1
28	2823021000	LED Holder Assy	1

No	Part No	Part Name	QTY
29	3421186000	Motor Housing	1
30	5700056000	Ball Bearing	1
31	5610076000	Tapping Screw	2
32	5630179000	Nut	1
33	3551635000	Spindle Lock	1
34	3660174000	Stop Spring	1
35	5620061000	Screw	1
36	3421190000	Spindle Lock Cover	1
37	5620069000	Screw	3
38	2823121000	Collet Assembly	1
39	5620041000	Screw	1
40	3320460000	Adjusting Knob	1
41	3123281000	Indicator	1
42	3550841000	Shaft	1
43	5660005000	"E" Ring	4
44	3660498000	Spring	4
45	3126054000	Handle Sleeve	4
46	3705047000	Lever	4
47	5620466000	Screw	2
48	5620467000	Screw	2
49	5650407000	Wave Washer	4
50	5650166000	Washer	2
51	3121637000	Chip Shield	1
52	3121635000	Handle	4
53	5620024000	Screw	4
54	2823122000	Lever Assy	2
55	3703872000	Plate	1
56	2823126000	Mounting Assy	1
57	5630015000	Nut	2
58	5650050000	Washer	1
59	5660177000	"E" Ring	1
60	3123294000	Dust Bracket	1
61	3125119000	Base Plate	1
62	5620074000	Screw	3

No	Part No	Part Name	QTY
63	2822272000	Adjusting Assy	1
64	5650337000	Washer	1
65	5620067000	Screw	1
66	5620032000	Screw	2
67	3123435000	Adjusting Knob	1
68	5650014000	Washer	1
69	3660313000	Spring	1
70	3550083000	Depth Adjusting Bolt	1
71	3550913000	Depth Stop Bar	1
72	3121634000	Depth Indicator	1
73	3121639000	Cover	1
74	5660018000	Circlips	1
75	3402338000	Lock Bolt	1
76	3123498000	Cap	1
77	5630016000	Nut	1
78	3123497000	Cover	1
79	2823123000	Plunge Frame	1
80	3660254000	Torsion Spring	1
81	5640045000	Bolt	1
82	3420398000	Plunge Lock Lever	1
83	5650007000	Spring Washer	1
84	5620040000	Screw	1
85	3123581000	Bollocks Seal	2
86	3660166000	Spring	2
87	5620103000	Screw	2
88	3700078000	Wave Washer	1
89	3420387000	Turntable	1
90	5700046000	Steel Ball	1
91	3660030000	Spring	1
92	2823112000	Mounting Assy	1
93	5660139000	"E" Ring	1
94	5650023000	Washer	1
95	3550929000	Bolt	1
96	3122923000	Base Plate	1

No	Part No	Part Name	QTY
97	5620074000	Screw	3
98	3402220000	Depth Adjusting Lever	1
99	2823125000	Collet Assy	1
100	3123454000	Vaccum Adapter	1
101	5620353000	Screw	2
102	3123500000	Support Plate	1
103	3550588000	Guiding Rod	2
104	3703925000	Fence	1
105	5650013000	Washer	2
106	5650015000	Spring Washer	2
107	5620050000	Screw	2
108	3123344000	Chip Shield	1
109	3402471000	Wrench	1
110	3123286000	Vaccum Adapter	1



## NOTES

## NOTES

## NOTES

# Get it fixed, at your home or ours!

## Your Home

For troubleshooting, product manuals and expert advice:



[www.managemylife.com](http://www.managemylife.com)

For repair – **in your home** – of **all** major brand appliances, lawn and garden equipment, or heating and cooling systems, **no matter who made it, no matter who sold it!**

For the replacement parts, accessories and owner's manuals that you need to do-it-yourself.

For Sears professional installation of home appliances and items like garage door openers and water heaters.

**1-800-4-MY-HOME®**

(1-800-469-4663)

[www.sears.com](http://www.sears.com)

Call anytime, day or night

(U.S.A. and Canada)

[www.sears.ca](http://www.sears.ca)

## Our Home

For repair of carry-in items like vacuums, lawn equipment, and electronics, call anytime for the location of the nearest

### Sears Parts & Repair Service Center

**1-800-488-1222** (U.S.A.)

[www.sears.com](http://www.sears.com)

**1-800-469-4663** (Canada)

[www.sears.ca](http://www.sears.ca)

To purchase a protection agreement on a product serviced by Sears:

**1-800-827-6655** (U.S.A.)

**1-800-361-6665** (Canada)

Para pedir servicio de reparación a domicilio, y para ordenar piezas:

**1-888-SU-HOGAR®**

(1-888-784-6427)

[www.sears.com](http://www.sears.com)

Au Canada pour service en français:

**1-800-LE-FOYER<sup>MC</sup>**

(1-800-533-6937)

[www.sears.ca](http://www.sears.ca)

# Sears

® Registered Trademark / <sup>TM</sup> Trademark of KCD IP, LLC in the United States, or Sears Brands, LLC in other countries

© Marca Registrada / <sup>TM</sup> Marca de Fábrica de KCD IP, LLC en Estados Unidos, o Sears Brands, LLC in otros países

<sup>MC</sup> Marque de commerce / <sup>MD</sup> Marque déposée de Sears Brands, LLC