

OPERATOR'S MANUAL

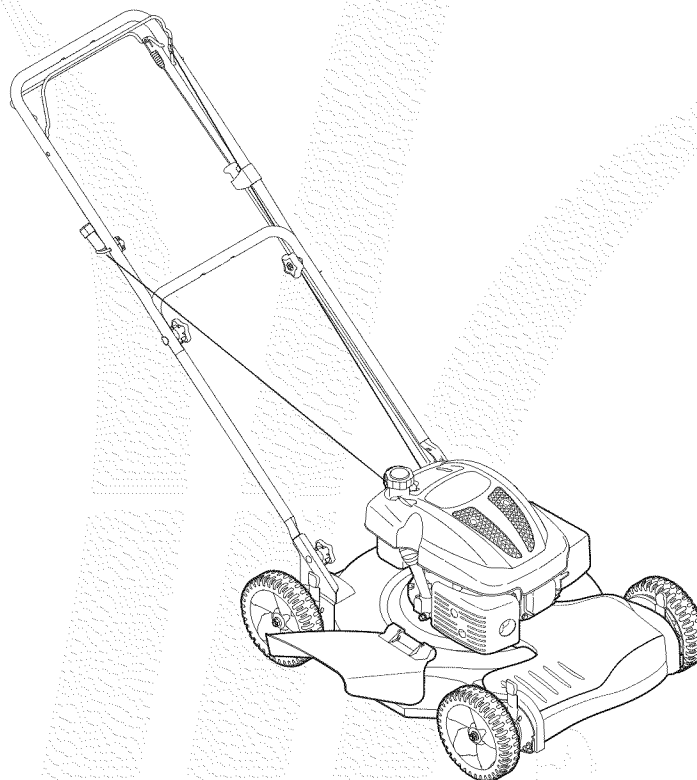

22-inch Rotary Mower — Model 26M

IMPORTANT

READ SAFETY RULES AND INSTRUCTIONS CAREFULLY BEFORE OPERATION

Warning: This unit is equipped with an internal combustion engine and should not be used on or near any unimproved forest-covered, brush-covered or grass-covered land unless the engine's exhaust system is equipped with a spark arrester meeting applicable local or state laws (if any). If a spark arrester is used, it should be maintained in effective working order by the operator. In the State of California the above is required by law (Section 4442 of the California Public Resources Code). Other states may have similar laws. Federal laws apply on federal lands. A spark arrester for the muffler is available through your nearest engine authorized service dealer or contact the service department, P.O. Box 361131 Cleveland, Ohio 44136-0019.

This Operator's Manual is an important part of your new lawn mower. It will help you assemble, prepare and maintain the unit for best performance. Please read and understand what it says.

Table of Contents

Slope Gauge	3	Engine Appendix	14
Safe Operation Practices	4	Engine Safe Operation Practices	14
Setup and Adjustment	6	Operating Your Engine	16
Operating Your Lawn Mower.....	8	Maintaining Your Engine	18
Maintaining Your Lawn Mower.....	10	Parts List	22
Trouble Shooting	12	Warranty	Back Cover
Off-Season Storage and Safety Labels	13		

Finding and Recording Model Number

BEFORE YOU BEGIN ASSEMBLING YOUR NEW EQUIPMENT, please locate the model plate on the equipment and copy the information to the sample model plate provided to the right. You can locate the model plate by standing at the operating position and looking down at the rear of the deck. This information will be necessary to use the manufacturer's web site, to obtain assistance from the Customer Support Department, or when contacting an authorized service dealer.



Customer Support

Please do **NOT** return the unit to the retailer from which it was purchased, without first contacting Customer Support.

If you have difficulty assembling this product or have any questions regarding the controls, operation, or maintenance of this unit, you can seek help from the experts. Choose from the options below:

- Visit us on the web at www.yardman.com
- Call a Customer Support Representative at **1-800-800-7310**.

1

Slope Gauge

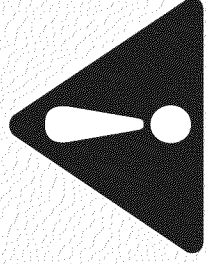

WARNING

Do not mow on inclines with a slope in excess of 15 degrees (a rise of approximately 2-1/2 feet every 10 feet). A riding mower could overturn and cause serious injury. If operating a walk-behind mower on such a slope, it is extremely difficult to maintain your footing and you could slip, resulting in serious injury.

Operate **RIDING** mowers up and down slopes, never across the face of slopes.

Operate **WALK-BEHIND** mowers across the face of slopes, never up and down slopes.

Use this page as a guide to determine slopes where you may not operate safely. **Do not operate** your lawn mower on such slopes.

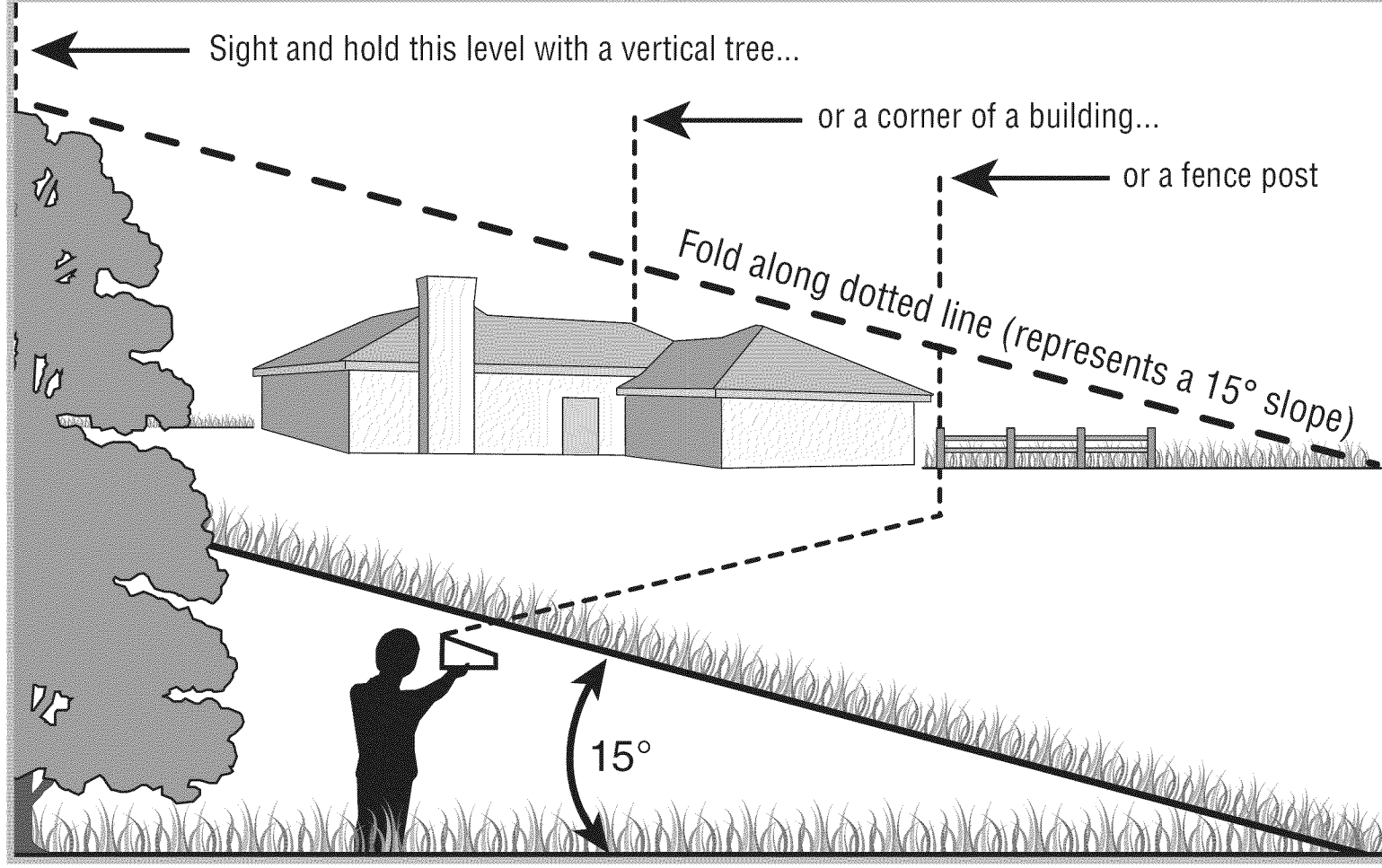

2

Safe Operation Practices



WARNING

This symbol points out important safety instructions which, if not followed, could endanger the personal safety and/or property of yourself and others. Read and follow all instructions in this manual before attempting to operate this machine. Failure to comply with these instructions may result in personal injury. When you see this symbol.

HEED ITS WARNING

Your Responsibility

Restrict the use of this power machine to persons who read, understand and follow the warnings and instructions in this manual and on the machine.



WARNING: Engine Exhaust, some of its constituents, and certain vehicle components contain or emit chemicals known to State of California to cause cancer and birth defects or other reproductive harm.

DANGER: This machine was built to be operated according to the rules for safe operation in this manual. As with any type of power equipment, carelessness or error on the part of the operator can result in serious injury. This machine is capable of amputating hands and feet and throwing objects. Failure to observe the following safety instructions could result in serious injury or death.

Children

Tragic accidents can occur if operator is not alert to presence of children. Children are often attracted to mower and mowing activity. They do not understand the dangers. Never assume that children will remain where you last saw them.

1. Keep children out of the mowing area and under watchful care of a responsible adult other than the operator.
2. Be alert and turn mower off if a child enters the area.
3. Before and while moving backwards, look behind and down for small children.
4. Use extreme care when approaching blind corners, doorways, shrubs, trees, or other objects that may obscure your vision of a child who may run into the mower.
5. Keep children away from hot or running engines. They can suffer burns from a hot muffler.
6. Never allow children under 14 years old to operate a power mower. Children 14 years old and over should read and understand operation instructions and safety rules in this manual and should be trained and supervised by a parent.

General Operation

1. Read this operator's manual carefully in its entirety before attempting to assemble this machine. Read, understand, and follow all instructions on the machine and in the manual(s) before operation. Be completely familiar with the controls and the proper use of this machine before operating it. Keep this manual in a safe place for future and regular reference and for ordering replacement parts.
2. This machine is a precision piece of power equipment, not a plaything. Therefore, exercise extreme caution at all times. Your unit has been designed to perform one job: to mow grass. Do not use it for any other purpose.
3. Never allow children under 14 years old to operate this machine. Children 14 years old and over should read and understand the instructions in this manual and should be trained and supervised by a parent. Only responsible individuals who are familiar with these rules of safe operation should be allowed to use this machine.
4. Thoroughly inspect the area where the equipment is to be used. Remove all stones, sticks, wire, bones, toys and other foreign objects which could be tripped over or picked up and thrown by the blade. Thrown objects can cause serious personal injury. Plan your mowing pattern to avoid discharge of material toward roads, sidewalks, bystanders and the like. Also, avoid discharging material against a wall or obstruction which may cause discharged material to ricochet back toward the operator.
5. To help avoid blade contact or a thrown object injury, stay in operator zone behind handles and keep children, bystanders, helpers, and pets at least 75 feet from mower while it is in operation. Stop machine if anyone enters area.
6. Always wear safety glasses or safety goggles during operation and while performing an adjustment or repair to protect your eyes. Thrown objects which ricochet can cause serious injury to the eyes.
7. Wear sturdy, rough-soled work shoes and close-fitting slacks and shirts. Shirts and pants that cover the arms and legs and steel-toed shoes are recommended. Never operate this machine in bare feet, sandals, slippery or light weight (e.g. canvas) shoes.
8. Do not put hands or feet near rotating parts or under cutting deck. Contact with blade can amputate hands and feet.
9. A missing or damaged discharge cover can cause blade contact or thrown object injuries.
10. Many injuries occur as a result of the mower being pulled over the foot during a fall caused by slipping or tripping. Do not hold on to the mower if you are falling; release the handle immediately.
11. Never pull the mower back toward you while you are walking. If you must back the mower away from a wall or obstruction first look down and behind to avoid tripping and then follow these steps:
 - a. Step back from mower to fully extend your arms.
 - b. Be sure you are well balanced with sure footing.
 - c. Pull the mower back slowly, no more than half way toward you.
 - d. Repeat these steps as needed.
12. Do not operate the mower while under the influence of alcohol or drugs.
13. Do not engage the self-propelled mechanism on units so equipped while starting engine.
14. The blade control handle is a safety device. Never attempt to bypass its operation. Doing so makes the safety device inoperative and may result in personal injury through contact with the rotating blade. The blade control handle must operate easily in both directions and automatically return to the disengaged position when released.
15. Never operate the mower in wet grass. Always be sure of your footing. A slip and fall can cause serious personal injury. If you feel you are losing your footing, release the blade control handle immediately and the blade will stop rotating within three seconds.
16. Mow only in daylight or good artificial light. Walk, never run.
17. Stop the blade when crossing gravel drives, walks or roads.
18. If the equipment should start to vibrate abnormally, stop the engine and check immediately for the cause. Vibration is generally a warning of trouble.
19. Shut the engine off and wait until the blade comes to a complete stop before removing the grass catcher or unclogging the chute.
The cutting blade continues to rotate for a few seconds

after the engine is shut off. Never place any part of the body in the blade area until you are sure the blade has stopped rotating.

- Never operate mower without proper trailshield, discharge cover, grass catcher, blade control handle, or other safety protective devices in place and working. Never operate mower with damaged safety devices. Failure to do so can result in personal injury.
- Muffler and engine become hot and can cause a burn. Do not touch.
- Only use parts and accessories made for this machine by manufacturer. Failure to do so can result in personal injury.
- If situations occur which are not covered in this manual, use care and good judgment. Contact your dealer for assistance. Telephone 1-800-800-7310 for the name of your nearest dealer.

Slope Operation

Slopes are a major factor related to slip and fall accidents which can result in severe injury. Operation on slopes requires extra caution. If you feel uneasy on a slope, do not mow it. For your safety, use the slope gauge included as part of this manual to measure slopes before operating this unit on a sloped or hilly area. If the slope is greater than 15 degrees, do not mow it.

Do:

- Mow across the face of slopes; never up and down. Exercise extreme caution when changing direction on slopes.
- Watch for holes, ruts, rocks, hidden objects, or bumps which can cause you to slip or trip. Tall grass can hide obstacles.
- Always be sure of your footing. A slip and fall can cause serious personal injury. If you feel you are losing your balance, release the blade control handle immediately, and the blade will stop rotating within 3 seconds.

Do Not:

- Do not mow near drop-offs, ditches or embankments, where you could lose your footing or balance.
- Do not mow slopes greater than 15 degrees as shown on the slope gauge.
- Do not mow on wet grass. Unstable footing could cause slipping.

Service

Safe Handling Of Gasoline:

- To avoid personal injury or property damage use extreme care in handling gasoline. Gasoline is extremely flammable and the vapors are explosive. Serious personal injury can occur when gasoline is spilled on yourself or your clothes which can ignite.
- Wash your skin and change clothes immediately.
- Use only an approved gasoline container.
- Never fill containers inside a vehicle or on a truck or trailer bed with a plastic liner. Always place containers on the ground away from your vehicle before filling.
- Remove gas-powered equipment from the truck or trailer and refuel it on the ground. If this is not possible, then refuel such equipment on a trailer with a portable container, rather than from a gasoline dispenser nozzle.
- Keep the nozzle in contact with the rim of the fuel tank or container opening at all times until fueling is complete. Do not use a nozzle lock-open device.
- Extinguish all cigarettes, cigars, pipes and other sources of ignition.
- Never fuel machine indoors because flammable vapors will

accumulate in the area.

- Never remove gas cap or add fuel while engine is hot or running. Allow engine to cool at least two minutes before refueling.
- Never over fill fuel tank. Fill tank to no more than ½ inch below bottom of filler neck to provide for fuel expansion.
- Replace gasoline cap and tighten securely.
- If gasoline is spilled, wipe it off the engine and equipment. Move unit to another area. Wait 5 minutes before starting engine.
- Never store the machine or fuel container near an open flame, spark or pilot light as on a water heater, space heater, furnace, clothes dryer, or other gas appliances.
- To reduce fire hazard, keep mower free of grass, leaves, or other debris build-up. Clean up oil or fuel spillage and remove any fuel soaked debris.
- Allow a mower to cool at least 5 minutes before storing.

General Service:

- Never run an engine indoors or in a poorly ventilated area. Engine exhaust contains carbon monoxide, an odorless and deadly gas.
- Before cleaning, repairing, or inspecting, make certain the blade and all moving parts have stopped. Disconnect the spark plug wire and ground against the engine to prevent unintended starting.
- Check the blade and engine mounting bolts at frequent intervals for proper tightness. Also, visually inspect blade for damage (e.g., bent, cracked, worn) Replace blade with the original equipment manufacturer's (O.E.M.) blade only, listed in this manual. "Use of parts which do not meet the original equipment specifications may lead to improper performance and compromise safety!"
- Mower blades are sharp and can cut. Wrap the blade or wear gloves, and use extra caution when servicing them.
- Keep all nuts, bolts, and screws tight to be sure the equipment is in safe working condition.
- Never tamper with safety devices. Check their proper operation regularly.
- After striking a foreign object, stop the engine, disconnect the spark plug wire and ground against the engine. Thoroughly inspect the mower for any damage. Repair the damage before starting and operating the mower.
- Never attempt to make a wheel or cutting height adjustment while the engine is running.
- Grass catcher components, discharge cover, and trail shield are subject to wear and damage which could expose moving parts or allow objects to be thrown. For safety protection, frequently check components and replace immediately with original equipment manufacturer's (O.E.M.) parts only, listed in this manual. "Use of parts which do not meet the original equipment specifications may lead to improper performance and compromise safety!"
- Do not change the engine governor setting or overspeed the engine. The governor controls the maximum safe operating speed of the engine.
- Maintain or replace safety labels, as necessary.
- Observe proper disposal laws and regulations. Improper disposal of fluids and materials can harm the environment.

2

Safe Operation Practices



WARNING

This symbol points out important safety instructions which, if not followed, could endanger the personal safety and/or property of yourself and others. Read and follow all instructions in this manual before attempting to operate this machine. Failure to comply with these instructions may result in personal injury. When you see this symbol.

HEED ITS WARNING

Your Responsibility

Restrict the use of this power machine to persons who read, understand and follow the warnings and instructions in this manual and on the machine.

3

Setup and Adjustment



WARNING

The chute retainer must be removed and discarded before operating the mower.



NOTE: Your mower is shipped with the handle in the higher position.

NOTE: Each end of the lower handle must be placed in the same relative position.

IMPORTANT

This unit is shipped without gasoline or oil in the engine. Fill up gasoline and oil as instructed in the engine operation section **BEFORE** operating your mower.

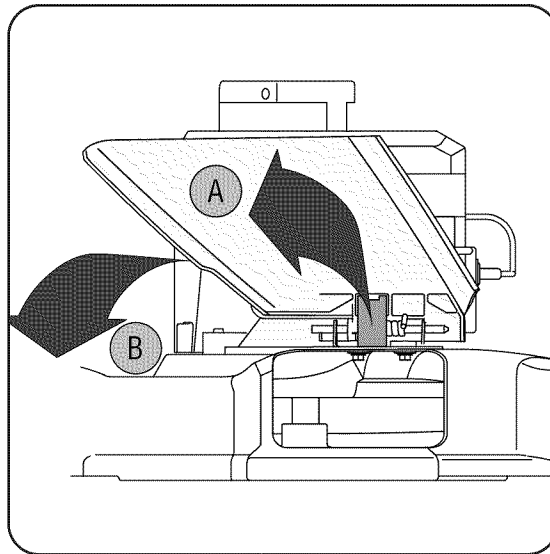

Step 1

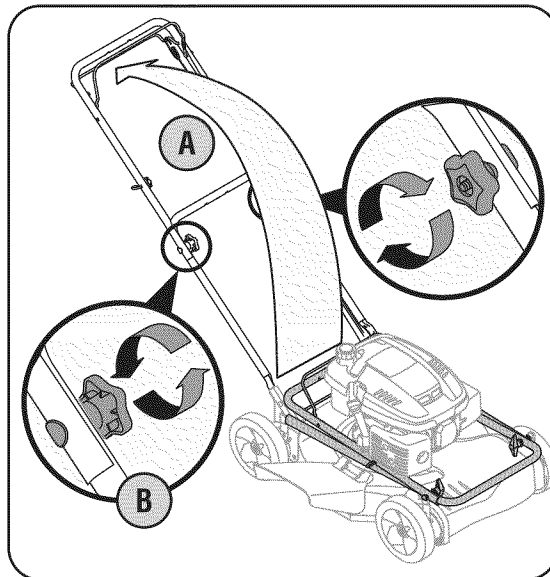

Step 2

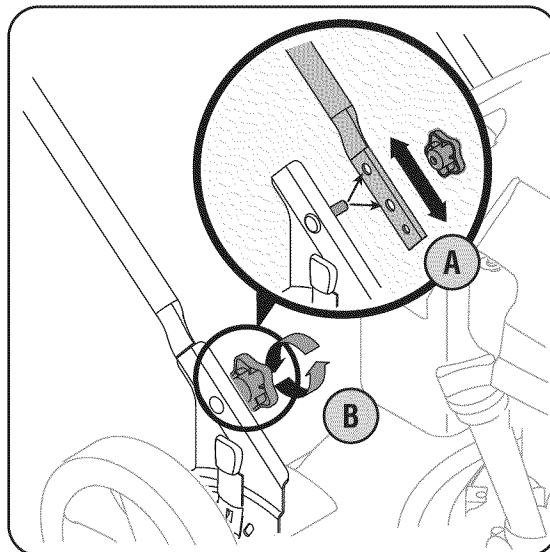

Step 3

1. For shipping purposes, the chute deflector on your mower is held in an upright position by a retainer. Remove the retainer as follows:
 - a. Push chute deflector up towards engine. Holding deflector in this position, remove the retainer and discard. See Step 1.
 - b. Lower the chute deflector carefully keeping your fingers out of the way.



WARNING: The chute retainer must be removed and discarded before operating the mower.

2. Perform the following sequence for handle setup:
 - a. Lift the upper handle up from folded position A and pull it to extended position B following the arrow in Step 2. The handle should click into this position.
 - b. Make sure the carriage bolt is seated properly in the handle. Tighten wing nuts securing upper handle to the lower handle
3. If satisfied with height of handle, tighten wing nuts at the ends of the lower handle shown in Step 3. For convenience of operating, you may adjust the handle height by removing the wing nuts shown in Step 3 and removing the lower handle.
 - a. Position each handle bracket stud into the top hole in the lower handle. See Step 3 inset.
 - b. Tighten the wing nuts.
4. Insert post on cable ties into holes provided on the lower handle. Pull cable tie tight and trim excess. See Step 4.

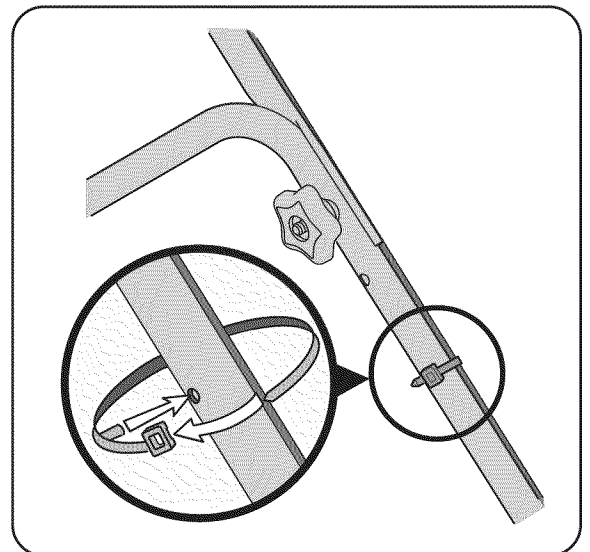

Step 4

5. Rope guide Setup as follows in Step 5:
 - a. Hold the blade control against the upper handle.
 - b. Slowly pull starter rope out of engine.
 - c. Slip starter rope into the rope guide.
 - d. Tighten rope guide wing nut.
6. Each wheel has a height adjustment lever to change the cutting height of the mower.
 - a. Depress height adjustment lever towards wheel.
 - b. Slide lever to desired position for a change in cutting height. See Step 6.
 - c. Release lever towards deck.
7. Install mulching baffle on the right side of the mower following the steps below:
 - a. Lift up and hold the side-discharge chute deflector and insert bottom lip of the mulching baffle inside the chute opening See Step 7.
 - b. Snap hooks of the mulching baffle over the hinge pin of the chute deflector. The hooks must snap into place on the hinge pin, locking the mulching baffle firmly onto mower. Release chute deflector.

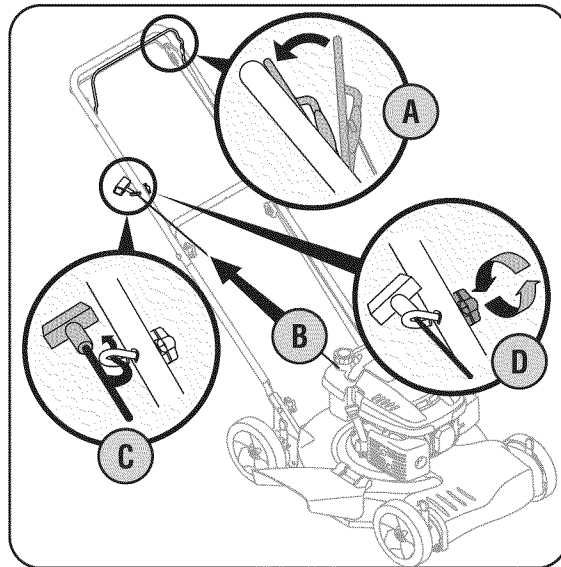

Step 5

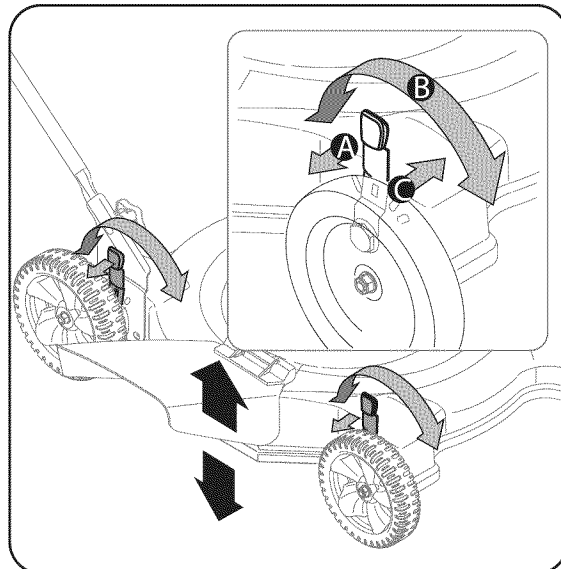

Step 6

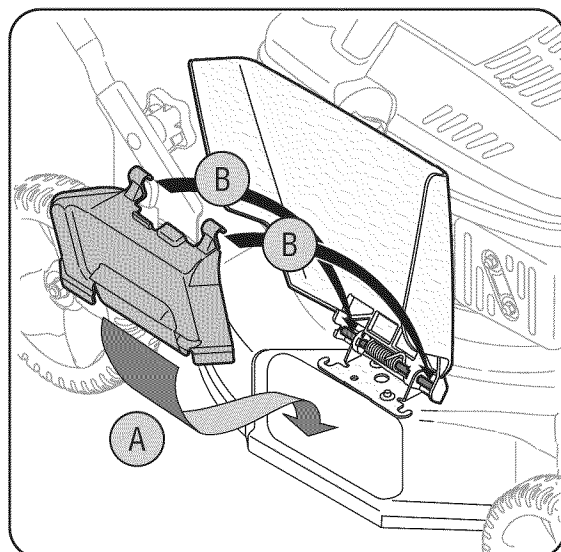

Step 7

3

Setup and Adjustment



CUTTING HEIGHT Step 6

All wheels must be placed in the same relative position. For rough or uneven lawns, move the height adjustment lever to a higher position. This will stop scalping of grass.

MULCHING BAFFLE Step 7

For proper assembly, install bottom lip inside chute opening before placing hooks over the hinge pin.

IMPORTANT

This unit is shipped without gasoline or oil in the engine. Fill up gasoline and oil as instructed in the engine operation section **BEFORE** operating your mower.

4

Operating Your Lawn Mower



WARNING

The blade control mechanism is a safety device. Never attempt to bypass its operations.

Use extreme care when handling gasoline. Gasoline is extremely flammable and the vapors are explosive. Never fuel the machine indoors or while the engine is hot or running. Extinguish cigarettes, cigars, pipes and other sources of ignition.

Keep hands and feet away from the chute area on cutting deck. Refer to warning label on the unit.

Know Your Lawn Mower

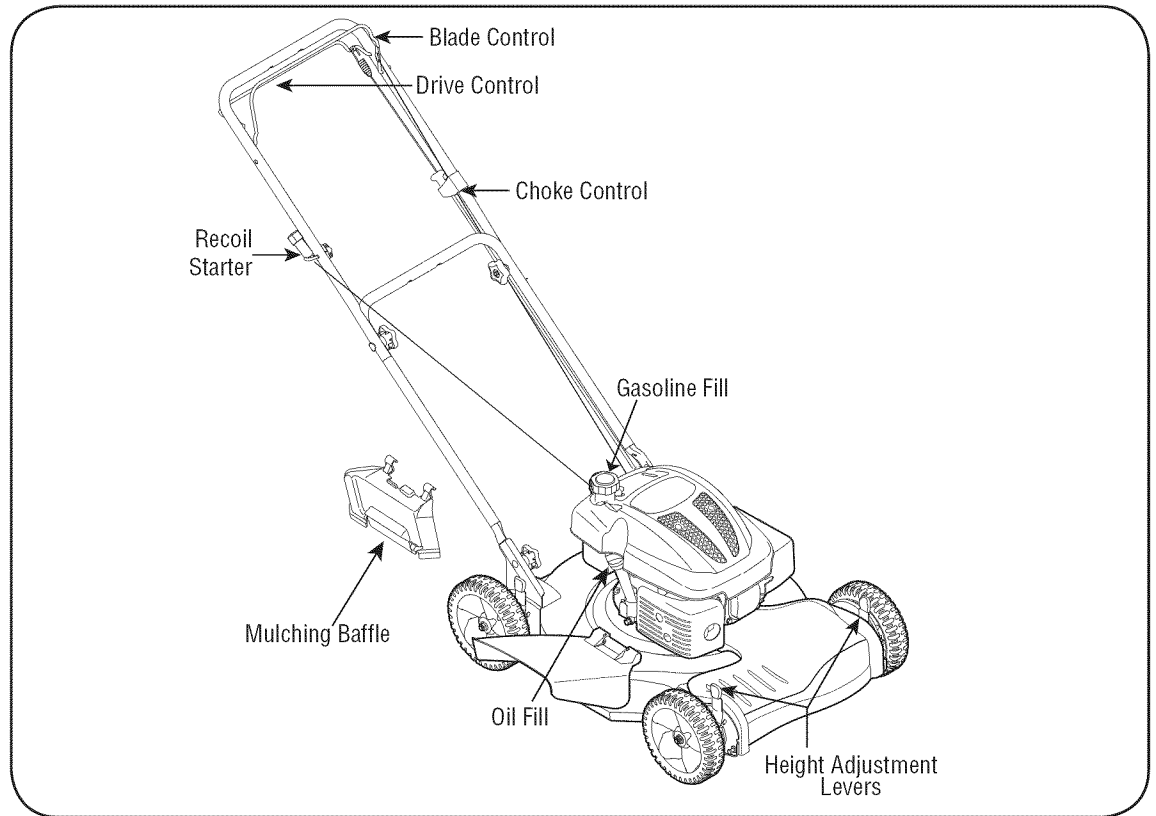

Figure 1

Now that you have setup your lawn mower, it's important to become acquainted with its controls and features.

Blade Control

The blade control is attached to the upper handle of the mower. Depress and squeeze it against the upper handle to operate the unit. Release it to stop engine and blade.



WARNING: This blade control mechanism is a safety device. Never attempt to bypass its operations.

Drive Control

The drive control is located on the underside of the upper handle and is used to engage the drive. Squeeze it against the upper handle to engage the drive; release it to slow down or stop mower from propelling.

Mulching Baffle

Instead of collecting the grass clippings in the grass catcher, your mower has the option of recirculating the clippings back to the lawn. Remove grass catcher (if applicable), and operate with the mulching baffle only for this purpose.

Cutting Height Adjustment Levers

One adjustment lever is located on each wheel and is used to adjust the cutting height. All four levers must be at the same position to ensure a uniform cut.

Recoil Starter

The recoil starter is attached to the right upper handle. Stand behind the unit and pull the recoil starter rope to start the unit.

Choke Control

The choke control is located on the left side of the handle and when activated, closes the choke plate on the carburetor and aids in starting the engine.

Gas and Oil Fill-Up

1. Add oil provided before starting unit for the first time out of the box. Follow engine operation section for this.
2. Service the engine with gasoline as instructed in the engine operation section.



WARNING: Use extreme care when handling gasoline. Gasoline is extremely flammable and the vapors are explosive. Never fuel the machine indoors or while the engine is hot or running. Extinguish cigarettes, cigars, pipes and other sources of ignition.



WARNING: The operation of any lawn mower can result in foreign objects being thrown into the eyes, which can damage your eyes severely. Always wear safety glasses while operating the mower, or while performing any adjustments or repairs on it.

Starting Engine



WARNING: Be sure no one other than the operator is standing near the lawn mower while starting engine or operating mower. Never run engine indoors or in enclosed, poorly ventilated areas. Engine exhaust contains carbon monoxide, an odorless and deadly gas. Keep hands, feet, hair and loose clothing away from any moving parts on engine and lawn mower.



WARNING: Always keep hands and feet clear of equipment moving parts. Do not use a pressurized starting fluid. Vapors are flammable.

1. Pull out the choke knob located on the left side of the upper handle. See Figure 2.

NOTE: Use of the choke may be necessary if the engine is warm or the air temperature is high.

2. Standing behind the mower, depress the blade control and hold it against the upper handle.
3. Pull the starter grip lightly until resistance is felt, then pull rapidly to overcome compression, prevent kickback and start engine. Repeat if necessary. See Figure 2.

IMPORTANT: Do not allow the starter grip to snap back against the rope guide. Return it gently to prevent damage to the starter.

4. When engine warms up, push in the choke knob. See Figure 2.

Stopping Engine

1. Release blade control to stop the engine and blade.

Using Your Lawn Mower



WARNING: Never operate your mower without either the rear door or the entire grass catcher assembly firmly secured.

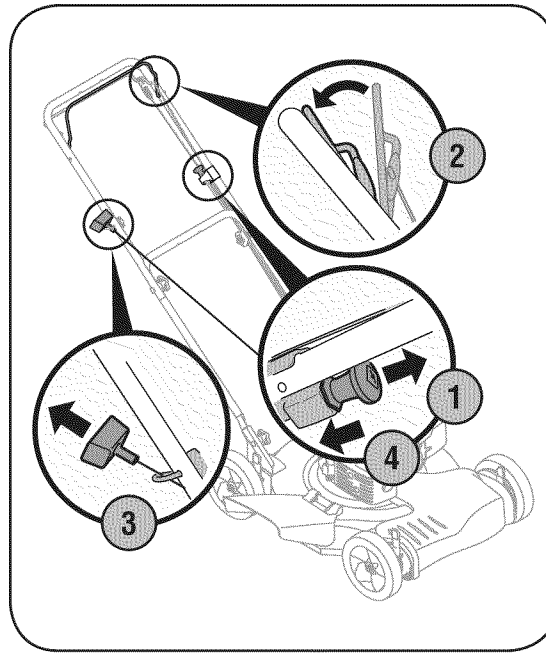

Figure 2

Be sure lawn is clear of stones, sticks, wire, or other objects which could damage lawn mower or engine. Such objects could be accidentally thrown by the mower in any direction and cause serious personal injury to the operator and others.



WARNING: If you strike a foreign object, stop the engine. Remove spark plug boot from the spark plug, thoroughly inspect mower for any damage, and repair damage before restarting and operating. Extensive vibration of mower during operation is an indication of damage. The unit should be promptly inspected and repaired.

1. Once the engine is running, squeeze the drive control against the upper handle to propel mower.
2. For best results, do not cut wet grass.
3. For a healthier lawn, never cut off more than one-third of the total length of the grass.

Using as Mulcher

For mulching grass, remove the grass catcher (if applicable) and install mulching baffle following instructions on page 7.

1. For effective mulching, do not cut wet grass.
2. New or thick grass may require a narrower cut. Adjust ground speed according to condition of lawn.
3. If the grass has been allowed to grow in excess of 4 inches, mulching is not recommended. Use the grass catcher to bag clippings instead.

4

Operating Your Lawn Mower



WARNING

The operation of any lawn mower can result in foreign objects being thrown into the eyes, which can damage your eyes severely. Always wear safety glasses while operating the mower, or while performing any adjustments or repairs on it.

Be sure no one other than the operator is standing near the lawn mower while starting engine or operating mower. Never run engine indoors or in enclosed, poorly ventilated areas. Engine exhaust contains carbon monoxide, an odorless and deadly gas. Keep hands, feet, hair and loose clothing away from any moving parts on engine and lawn mower.

5

Maintaining Your Lawn Mower



WARNING

Always stop engine, disconnect spark plug, and ground against engine before performing any type of maintenance on your machine.



We do not recommend the use of a pressure washer or garden hose to clean your unit. These may cause damage to electric components, spindles, pulleys, bearings, or the engine. The use of water will result in shortened life and reduce serviceability.

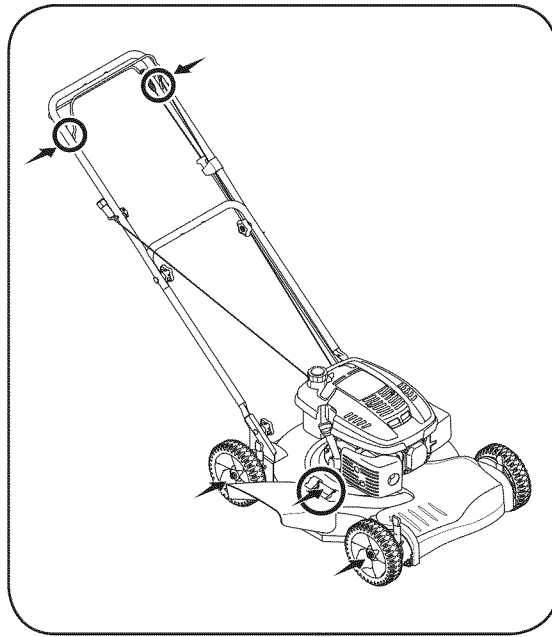

Figure 3

General Recommendations

1. Always observe safety rules when performing any maintenance.
2. The warranty on this lawn mower does not cover items that have been subjected to operator abuse or negligence. To receive full value from warranty, operator must maintain the lawn mower as instructed here.
3. Changing of engine-governed speed will void engine warranty.
4. All adjustments should be checked at least once each season.
5. Periodically check all fasteners and make sure these are tight.



WARNING: Always stop engine, disconnect spark plug, and ground against engine before cleaning, lubricating or doing any kind of maintenance on your machine.

Lubrication

1. Lubricate pivot points on the blade control and drive control at least once a season with light oil. These controls must operate freely in both directions. See Figure 3.
2. Lubricate the wheels at least once a season with light oil (or motor oil). If wheels are removed for any reason, lubricate surface of the pivot arm and inner surface of the wheel with light oil. See Figure 3.
3. Lubricate the torsion spring and pivot point on each end of the side mulching plug/ chute deflector periodically with light oil to prevent rust. See Figure 3.
4. The transmission is pre-lubricated and sealed at the factory and does not require lubrication.
5. Follow the engine maintenance section for lubrication schedule and instruction for engine lubrication.

Deck Care

1. Disconnect spark plug boot. Drain gasoline from lawn mower, or place a piece of plastic under the gas cap.
2. Tip mower so that it rests on the housing. Keep the side with the air cleaner facing up. Hold mower firmly.



WARNING: Never tip the mower more than 90 degrees in any directions and do not leave the mower tipped for any length of time. Oil can drain into the upper part of the engine causing a starting problem.

3. Scrape and clean the underside of the deck with a suitable tool. Do not spray with water.
4. Put the mower back on its wheels on the ground. If you had put plastic under the gas cap earlier, make sure to remove it now.

Engine Care

1. Maintain oil level as instructed in the engine maintenance section.
2. Service air cleaner every 25 hours under normal conditions. Clean every few hours under extremely dusty conditions. Refer to the engine maintenance section.
3. Clean spark plug and reset the gap once a season. Check the engine maintenance section for correct plug type and gap specifications.
4. Clean engine regularly with a cloth or brush. Keep the cooling system (blower housing area) clean to permit proper air circulation. Remove all grass, dirt and combustible debris from muffler area.

Blade Care



WARNING: When removing cutting blade for sharpening or replacement, protect your hands with a pair of heavy gloves or use a heavy rag to hold blade.

1. Disconnect spark plug boot from spark plug. Turn mower on its side making sure that the air filter and the carburetor are up.
2. Remove bolt, blade bell support, blade, and blade adapter from the engine crankshaft. See Figure 4.
3. The blade can be sharpened with a file or on a grinding wheel. Do not attempt to sharpen the blade while it is still on the mower. When sharpening blade, follow original angle of grind. Grind cutting edges equally to keep blade balanced.
4. Remove blade from the adapter for testing balance. Balance the blade on a round shaft screwdriver to check. Remove metal from the heavy side until it balances evenly.



WARNING: An unbalanced blade will cause excessive vibration when rotating at high speeds. It may cause damage to mower, and could break causing personal injury.

5. Lubricate the engine crankshaft and the inner surface of the blade adapter with light oil. Slide the blade adapter onto the engine crankshaft. Place the blade on the adapter such that the side of the blade marked "Bottom" (or with part number) faces the ground when the mower is in the operating position. Make sure that blade is aligned and seated on blade adapter flanges.
6. Place blade bell support on the blade. Align notches on the blade bell support with small holes in blade. Replace hex bolt and tighten hex bolt to torque: 450 in. lbs. min., 600 in. lbs. max.

To ensure safe operation of your mower, periodically check the blade bolt for correct torque.

Belt Care

1. Remove the front drive cover by sliding off the two plastic rivets on each side of the cover with a screwdriver. See Figure 5.
2. Loosen screw holding belt tension spring to transmission. See Figure 5 inset. Do not remove screw completely. As you loosen it, tension on the belt will be released.
3. Push transmission up a little and slide belt off the transmission pulley. Lift mower to access belt from underside of mower. Slide belt off of engine pulley and around the blade. See Figure 6.

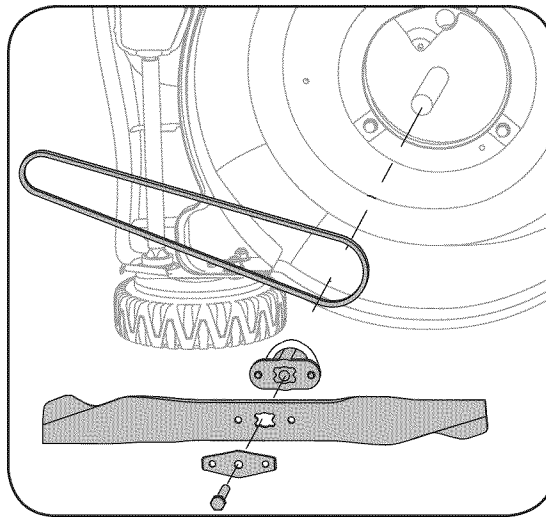

Figure 4

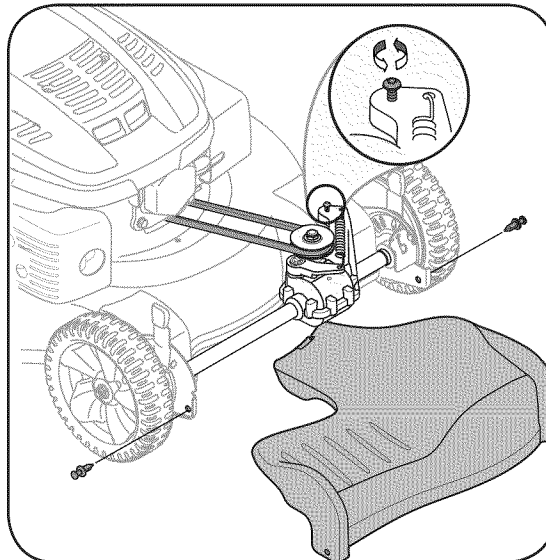

Figure 5

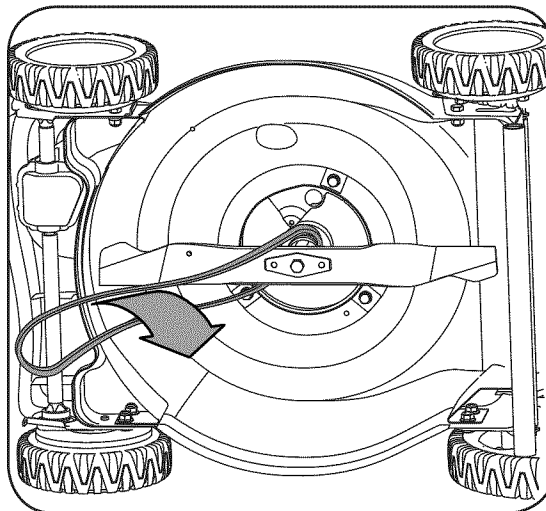

Figure 6

4. Replace with new belt, working around blade. Make sure belt is firmly seated on engine pulley while pulling from the other side and sliding it around the transmission pulley. Tighten screw loosened earlier to secure belt tension spring to the transmission. Reassemble front drive cover.

5

Maintaining Your Lawn Mower



WARNING

When removing the cutting blade for sharpening or replacement or when sliding the belt around it, protect your hands with a pair of heavy gloves or use a heavy rag to hold the blade.

An unbalanced blade will cause excessive vibration when rotating at high speeds. It may cause damage to mower, and could break causing personal injury.

6

Trouble Shooting



For repairs beyond the minor adjustments listed here, contact an authorized service dealer.

Problem	Cause	Remedy
Engine fails to start	<ol style="list-style-type: none"> 1. Blade control disengaged. 2. Spark plug boot disconnected. 3. Fuel tank empty or stale fuel. 4. CHOKE not activated. 5. Faulty spark plug. 6. Blocked fuel line. 7. Engine flooded. 	<ol style="list-style-type: none"> 1. Engage blade control. 2. Connect wire to spark plug. 3. Fill tank with clean, fresh gasoline. 4. Choke engine as instructed in "Operating Your Lawn Mower". 5. Clean, adjust gap, or replace. 6. Clean fuel line. 7. Wait a few minutes to restart.
Engine runs erratic	<ol style="list-style-type: none"> 1. Spark plug boot loose. 2. Blocked fuel line or stale fuel. 3. Vent in gas cap plugged. 4. Water or dirt in fuel system. 5. Dirty air cleaner. 6. Unit running with CHOKE applied. 	<ol style="list-style-type: none"> 1. Connect and tighten spark plug boot. 2. Clean fuel line; fill tank with clean, fresh gasoline. 3. Clear vent. 4. Drain fuel tank. Refill with fresh fuel. 5. Refer to engine maintenance section. 6. Push CHOKE knob in.
Engine overheats	<ol style="list-style-type: none"> 1. Engine oil level low. 2. Air flow restricted. 	<ol style="list-style-type: none"> 1. Fill crankcase with proper oil. 2. Remove blower housing and clean.
Occasional skips (hesitates) at high speed	<ol style="list-style-type: none"> 1. Spark plug gap too close. 	<ol style="list-style-type: none"> 1. Adjust gap to .030".
Idles poorly	<ol style="list-style-type: none"> 1. Spark plug fouled, faulty or gap too wide. 2. Dirty air cleaner. 	<ol style="list-style-type: none"> 1. Reset gap to .030" or replace spark plug. 2. Refer to engine maintenance section.
Excessive Vibration	<ol style="list-style-type: none"> 1. Cutting blade loose or unbalanced. 2. Bent cutting blade. 	<ol style="list-style-type: none"> 1. Tighten blade and adapter. Balance blade. 2. See an authorized service dealer.
Mower will not mulch grass (If Equipped)	<ol style="list-style-type: none"> 1. Wet grass. 2. Excessively high grass. 3. Dull blade. 	<ol style="list-style-type: none"> 1. Do not mow when grass is wet; wait until later to cut. 2. Mow once at a high cutting height, then mow again at desired height or make a narrower cutting path. 3. Sharpen or replace blade.
Uneven cut	<ol style="list-style-type: none"> 1. Wheels not positioned correctly. 2. Dull blade. 	<ol style="list-style-type: none"> 1. Place all four wheels in same height position. 2. Sharpen or replace blade.
Mower will not self propel	<ol style="list-style-type: none"> 1. Belt not installed properly. 2. Debris clogging drive operation. 3. Damaged or worn belt. 	<ol style="list-style-type: none"> 1. Check belt for proper pulley installation and movement. 2. Stop engine, disconnect spark plug boot and clean out debris. 3. Inspect and replace belt.

Off-Season Storage

The following steps should be taken to prepare your lawn mower for storage.

1. Clean and lubricate mower thoroughly as described in the lubrication instructions.
2. We do not recommend the use of a pressure washer or garden hose to clean your unit.
3. Refer to engine manual for correct engine storage instructions.

4. Coat mower's cutting blade with chassis grease to prevent rusting.
5. Store mower in a dry, clean area. Do not store next to corrosive materials, such as fertilizer.

When storing any type of power equipment in a poorly ventilated or metal storage shed, care should be taken to rust-proof the equipment. Using a light oil or silicone, coat the equipment, especially cables and all moving parts of your lawn mower before storage.

Safety Labels Found On Your Lawn Mower



⚠ DANGER
AVOID SERIOUS INJURY OR DEATH

- KEEP HANDS AND FEET AWAY FROM ROTATING PARTS.
- REMOVE OBJECTS THAT CAN BE THROWN BY THE BLADE IN ANY DIRECTION. WEAR SAFETY GLASSES.
- DO NOT MOW WHEN CHILDREN OR OTHERS ARE AROUND.
- USE EXTRA CAUTION ON SLOPES. DO NOT MOW SLOPES GREATER THAN 15°. MOW ACROSS, NEVER UP AND DOWN. NEVER PULL MOWER CLOSE TO YOUR FEET. LOOK DOWN AND BEHIND BEFORE AND WHILE MOVING BACKWARDS.

READ OPERATOR'S MANUAL KEEP SAFETY DEVICES (BLADE CONTROL, TRAILING SHIELD, DISCHARGE COVER, ETC) IN PLACE AND WORKING. IF DAMAGED, REPLACE IMMEDIATELY.



TO REDUCE THE RISK OF INJURY, DO NOT OPERATE UNLESS DISCHARGE COVER OR GRASS CATCHER IS IN ITS PROPER PLACE. IF DAMAGED, REPLACE IMMEDIATELY.

DANGER

KEEP HANDS and FEET AWAY



S32102 CD

⚠ WARNING	
	Read and follow Operating Instructions before running engine.
	Gasoline is flammable. Allow engine to cool at least 2 minutes before refueling.
	Engines emit carbon monoxide. DO NOT run in enclosed area.

7

Off Season Storage and Safety Labels



WARNING

DO NOT remove safety (or any) labels from mower for any reason.

8

Engine Safe Operation Practices



WARNING

Gasoline and its vapors are extremely flammable and explosive. Fire or explosion can cause severe burns or death. If gasoline is spilled on yourself or your clothes, wash your skin and change clothes immediately.

Starting engine creates sparking. Sparking can ignite nearby flammable gases. Explosion and fire could result.

Unintentional sparking can result in fire or electric shock. Unintentional start-up can result in entanglement, traumatic amputation, or laceration.



WARNING: Gasoline and its vapors are extremely flammable and explosive. Fire or explosion can cause severe burns or death. If gasoline is spilled on yourself or your clothes, wash your skin and change clothes immediately.



Gasoline and its vapors are extremely flammable and explosive. Fire or explosion can cause severe burns or death. If gasoline is spilled on yourself or your clothes, wash your skin and change clothes immediately.

- When adding fuel, turn engine OFF and let engine cool at least 2 minutes before removing gas cap.
- Fill fuel tank outdoors or in well ventilated area.
- Use only an approved gasoline container.
- Never fill containers inside a vehicle or on a truck or trailer bed with a plastic liner. Always place containers on the ground away from your vehicle before filling.
- If possible, remove gas-powered equipment from the truck or trailer and refuel it on the ground. If this is not possible, then refuel such equipment on a trailer with a portable container, rather than from a gasoline dispenser nozzle.
- Keep the nozzle in contact with the rim of the fuel tank or container opening at all times until fueling is complete. Do not use a nozzle lock-open device.
- Do not overfill fuel tank. Fill tank to approximately 2 cm below lowest portion of neck to allow for fuel expansion.
- Keep gasoline away from sparks, open flames, pilot lights, heat, and other ignition sources.
- Never fuel equipment indoors because flammable vapors will accumulate in the area.
- Extinguish all cigarettes, cigars, pipes, and other sources of ignition.
- Check fuel line, tank, cap, and fittings frequently for cracks or leaks. Replace if necessary.
- When starting engine, make sure spark plug, muffler, fuel cap and air cleaner are in place.
- Do not crank engine with spark plug removed.
- If fuel spills, wait until it evaporates before starting engine.

- When operating equipment, do not tip engine or equipment at angle which causes gasoline to spill.
- Do not choke carburetor to stop engine.
- When transporting equipment, transport with fuel tank EMPTY.
- When storing gasoline or equipment with fuel in tank, store away from furnaces, stoves, water heaters or other appliances that have pilot light or other ignition source because they can ignite gasoline vapors.



Starting engine creates sparking. Sparking can ignite nearby flammable gases. Explosion and fire could result.

- If there is a natural or LP gas leakage in area, do not start engine.
- Do not use pressurized starting fluids because vapors are flammable.



Engines give off carbon monoxide, an odorless, colorless, poisonous gas. Breathing carbon monoxide can cause nausea, fainting, or death.

- Start and run engine outdoors.
- Do not start or run engine in enclosed area, even if doors or windows are open.



Unintentional sparking can result in fire or electric shock. Unintentional start-up can result in entanglement, traumatic amputation, or laceration.

- Before performing adjustments or repairs, disconnect spark plug wire and keep it away from spark plug.
- When testing for spark, use approved spark plug tester.
- Do not check for spark with spark plug removed.



Running engine produces heat. Engine parts, especially muffler, become extremely hot. Severe thermal burns can occur on contact. Combustible debris, such as leaves, grass, brush, etc., can catch fire.

- Allow muffler, engine cylinder, and fins to cool before touching.
- Keep children away from hot or running engines. They can suffer burns from a hot muffler.
- Remove accumulated combustibles from muffler and cylinder area.



Rapid retraction of starter cord (kickback) will pull hand and arm toward engine faster than you can let go. Broken bones, fractures, bruises or sprains could result.

- Tie up long hair and remove jewelry.
- Do not wear loose-fitting clothing, dangling drawstrings or items that could become caught.
- When starting engine, pull cord slowly until resistance is felt, then pull rapidly.
- Remove all external equipment/engine loads before starting engine.
- Direct coupled equipment components such as, but not limited to blades, impellers, pulleys, sprockets, etc., must be securely attached.



Rotating engine parts can contact or entangle hands, feet, hair, clothing, or accessories. Traumatic amputation or severe laceration can result.

- Operate equipment with guards in place.
- Keep hands and feet away from rotating parts.

Safety Label Location

This label warns you of potential hazards that can cause serious injury. Read it carefully. See Figure 1 for explanation of symbols. If the label comes off or becomes hard to read, contact the dealer for replacement.

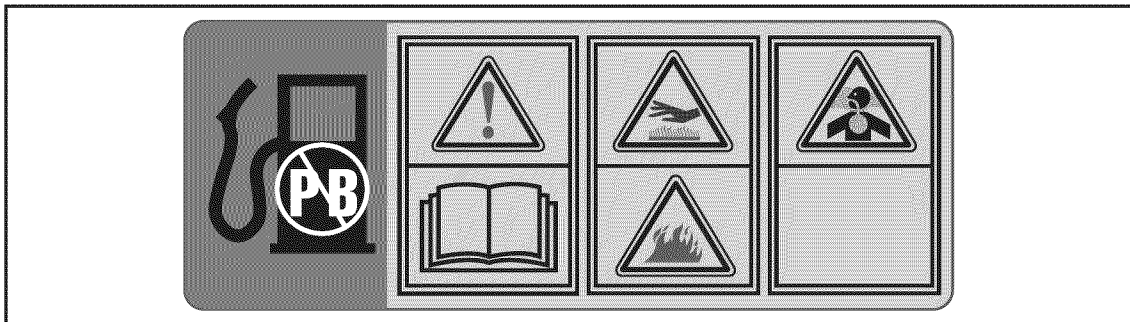

International Symbols and Meanings

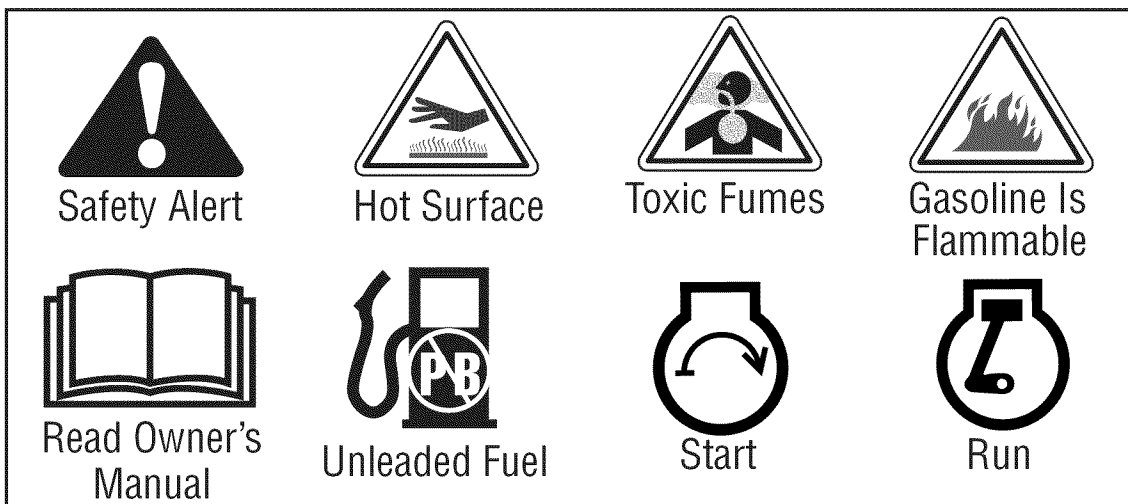

Figure 1

8

Engine Safe Operation Practices



WARNING

Running engine produces heat. Engine parts, especially muffler, become extremely hot. Severe thermal burns can occur on contact. Combustible debris, such as leaves, grass, brush, etc., can catch fire.

Rotating engine parts can contact or entangle hands, feet, hair, clothing, or accessories. Traumatic amputation or severe laceration can result.

Rapid retraction of starter cord (kickback) will pull hand and arm toward engine faster than you can let go. Broken bones, fractures, bruises or sprains could result.

9

Operating Your Engine



IMPORTANT: This engine is shipped without gasoline or oil in the engine. Running the engine with insufficient oil can cause serious engine damage and void the engine warranty.

IMPORTANT: Using non-detergent oil or 2-stroke engine oil could shorten the engine's service life.

Be sure to check the engine on a level surface with the engine stopped.

Know Your Engine

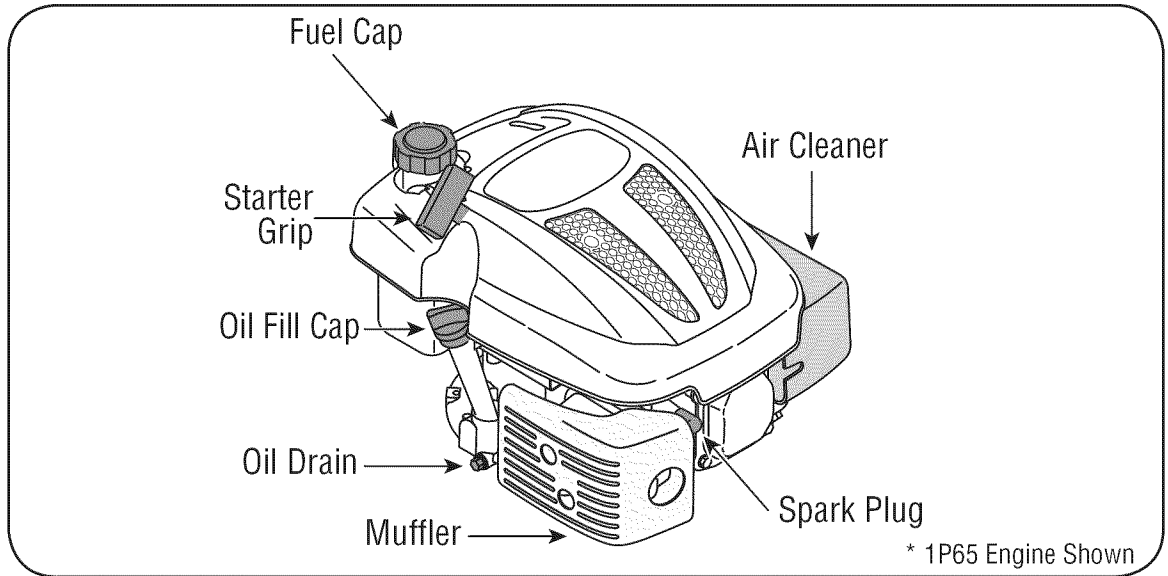

Figure 9-1: The major components of the engine. The shroud on your engine may differ.

Read this section before starting your lawn mower engine. Compare the illustrations in Figure 9-1 with your lawn mower engine to familiarize yourself with the location of various controls and adjustments.

Pre-Operation Check

Oil Recommendations

IMPORTANT: This engine is shipped without gasoline or oil in the engine. Running the engine with insufficient oil can cause serious engine damage and void the engine warranty.

- Before starting engine, fill with oil. Do not over-fill. Oil capacity is about 20 oz.

Use a 4-stroke, or an equivalent high detergent, premium quality motor oil certified to meet or exceed U.S. automobile manufacturer's requirements for service classification SG, SF. Motor oils classified SG, SF will show this designation on the container.

SAE 10W-30 is recommended for general, all temperature use. If single viscosity oil is used, select the appropriate viscosity for the average temperature in your area from the chart to the right.

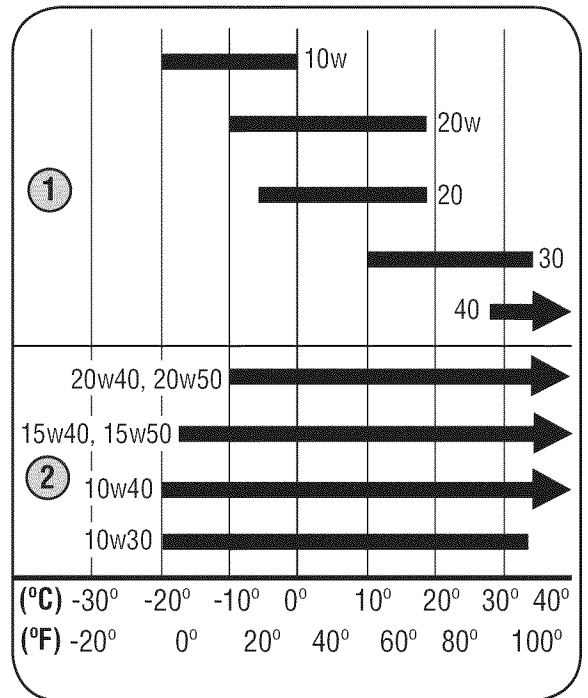

Ambient Temperature

1. Single Viscosity
2. Multi Viscosity

IMPORTANT: Using nondetergent oil or 2-stroke engine oil could shorten the engine's service life.

Check Oil Level

IMPORTANT: Be sure to check the engine on a level surface with the engine stopped.

1. Remove the oil filler cap and wipe the dipstick clean, Figure 9-2.
2. Insert the dipstick into the oil filler neck, but do not screw it in.
3. If the level is low, slowly add oil to the upper limit on the dipstick.
4. Tighten dipstick firmly before starting engine.

IMPORTANT: Do not overfill. Overfilling with oil may cause smoking, hard starting, spark plug fouling, or oil saturation of air cleaner.

Fuel Recommendations

Use automotive gasoline (Unleaded or lowleaded to minimize combustion chamber deposits). Never use an oil/gasoline mixture or dirty gasoline. Avoid getting dirt, dust, or water in the fuel tank.



WARNING: Gasoline is extremely flammable and is explosive under certain conditions.

Refuel in a well-ventilated area with the engine stopped. Do not smoke or allow flames or sparks in the area where the engine is refueled or where gasoline is stored.

Do not overfill the fuel tank (there should be no fuel in the filler neck). After refueling, make sure the tank cap is closed properly and securely.

Be careful not to spill fuel when refueling. Spilled fuel or fuel vapor may ignite. If any fuel is spilled, make sure the area is dry before starting the engine.

Avoid repeated or prolonged contact with skin or breathing of vapor.

Check Fuel Level

1. Clean around fuel fill before removing cap to fuel.
2. Fill tank to approximately one inch below lowest portion of neck to allow for fuel expansion. Be careful not to overfill.

IMPORTANT: Before refueling, allow engine to cool two minutes.

Starting The Engine



WARNING: Always keep hands and feet clear of equipment moving parts. Do not use a pressurized starting fluid. Vapors are flammable.

1. Pull out the choke knob located on the left side of the upper handle, Figure 9-3.

NOTE: Use of the choke may not be necessary if the engine is warm or the air temperature is high.

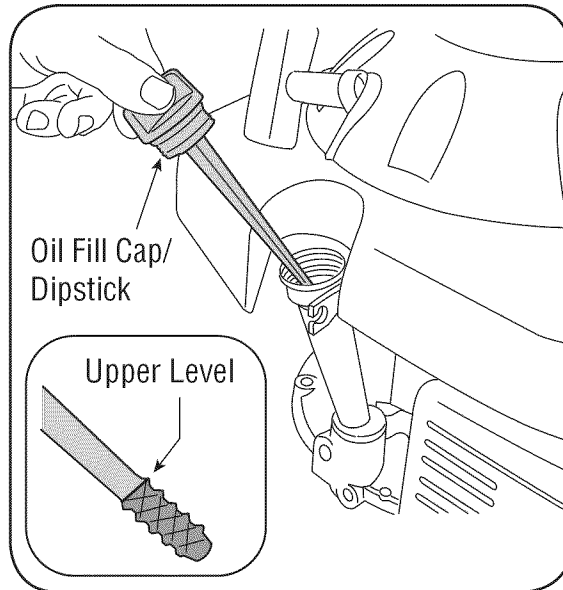

Figure 9-2: Checking the oil level.

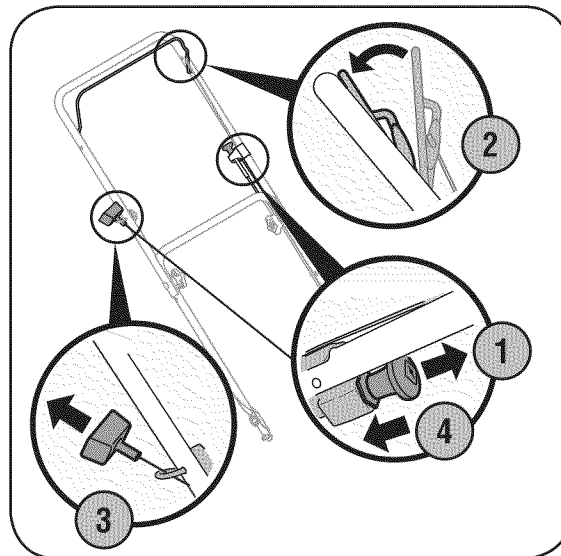

Figure 9-3: Starting the mower. (Your mower may differ from that shown)

2. Standing behind the mower, depress the blade control handle and hold it against the upper handle.
3. Pull the starter grip lightly until resistance is felt, then pull rapidly to overcome compression, prevent kickback and start engine. Repeat if necessary.
4. When engine warms up, push in the choke knob.

IMPORTANT: Do not allow the starter grip to snap back against the rope guide. Return it gently to prevent damage to the starter.

Stopping The Engine

1. Release the blade control handle.

9

Operating Your Engine



WARNING

Always keep hands and feet clear of equipment moving parts. Do not use a pressurized starting fluid. Vapors are flammable.



IMPORTANT: Do not allow the starter grip to snap back against the engine. Return it gently to prevent damage to the starter.

10

Maintaining Your Engine



WARNING

Shut off the engine before performing any maintenance. To prevent accidental start-up, disconnect the spark plug boot.

Before tipping engine or equipment to drain oil, drain fuel from tank by running engine until fuel tank is empty.



IMPORTANT

Be sure to check engine on a level surface with the engine stopped. Drain the oil while the engine is still warm to assure rapid and complete draining.



WARNING: Shut off the engine before performing any maintenance. To prevent accidental start-up, disconnect the spark plug boot.

IMPORTANT: If engine must be tipped to transport equipment or to inspect or remove grass, keep spark plug side of engine up. Transporting or tipping engine spark plug down may cause smoking, hard starting, spark plug fouling, or oil saturation of air cleaner.

Periodic inspection and adjustment of the engine is essential if high level performance is to be maintained. Regular maintenance will also ensure a long service life. The required service intervals and the kind of maintenance to be performed are described in the table below. Follow the hourly or calendar intervals, whichever occur first. More frequent service is required when operating in adverse conditions.

Maintenance Schedule

Tasks	First 5 hours	Each use or every 5 hours	Every season or 25 hours	Every season or 50 hours	Every season or 100 hours	Service Dates
Check Engine Oil		✓				
Change Engine Oil	✓		✓ ^{††}	✓		
Check Air Cleaner		✓				
Service Air Cleaner			✓ [†]			
Check Spark Plug			✓			
Service Spark Plug					✓	
Clean Finger Guard		✓				
Clean Around Muffler		✓				

† Service more frequently when used in dusty areas.

†† If operating under heavy load or high ambient temperature.

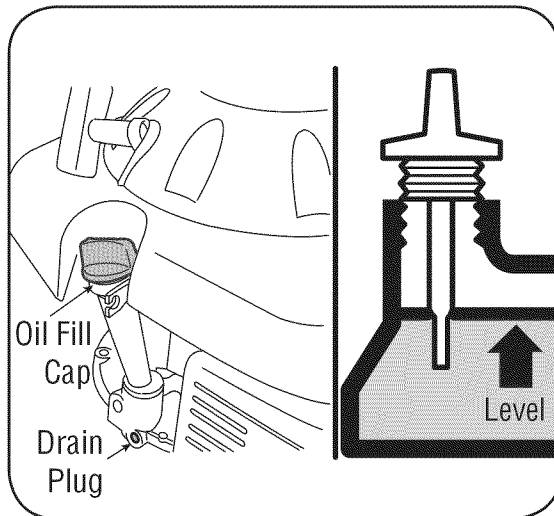

Figure 5

Oil Service

- Check oil level regularly.
- Be sure correct oil level is maintained. Check every 5 hours or daily before starting engine. See oil checking procedure in the Operation section.

Oil Change

IMPORTANT: Be sure to check engine on a level surface with the engine stopped. Drain the oil while the engine is still warm to assure rapid and complete draining.

1. Remove oil fill cap and drain oil by either removing drain plug or turning mower on its side (air cleaner side up) and allowing oil to drain into a suitable container. See Figure 5.



WARNING: Before tipping engine or equipment to drain oil, drain fuel from tank by running engine until fuel tank is empty.

2. Reinstall the drain plug (if removed), and tighten it securely.
3. Refill with the recommended oil (see Operation section) and check the oil level. See Figure 5.
4. Reinstall the oil fill cap securely.

IMPORTANT: Used motor oil may cause skin cancer if repeatedly left in contact with the skin for prolonged periods. Although this is unlikely unless you handle used oil on a daily basis, it is still advisable to thoroughly wash your hands with soap and water as soon as possible after handling used oil.

NOTE: Please dispose of used motor oil in a manner that is compatible with the environment. We suggest you take it in a sealed container to your local service station for reclamation. Do not throw it in the trash or pour it on the ground.

Air Cleaner Service

A dirty air cleaner will restrict air flow to the carburetor. To prevent carburetor malfunction, service the air cleaner regularly. Service more frequently when operating the engine in extremely dusty areas.



WARNING: Never use gasoline or low flash point solvents for cleaning the air cleaner element. A fire or explosion could result.

IMPORTANT: Never run the engine without the air cleaner. Rapid engine wear will result.

1. Remove the wing bolt and the air cleaner cover. Remove the elements and separate them. See Figure 6. Carefully check both elements for holes or tears and replace if damaged.
2. **Foam element:** Wash the element in a solution of household detergent and warm water, then rinse thoroughly, or wash in nonflammable or high flash point solvent. Allow the element to dry thoroughly. Soak the element in clean engine oil and squeeze out the excess oil. The engine will smoke during initial start-up if too much oil is left in the foam.
3. **Paper element:** Tap the element lightly several times on a hard surface to remove excess dirt, or blow compressed air through the filter from the inside out. Never try to brush the dirt off; brushing will force dirt into the fibers. Replace the paper element if it is excessively dirty.

Spark Plug Service



WARNING: DO NOT check for spark with spark plug removed. DO NOT crank engine with spark plug removed.

To ensure proper engine operation, the spark plug must be properly gapped and free of deposits.

1. Remove the spark plug boot and use a spark plug wrench to remove the plug. See Figure 7.

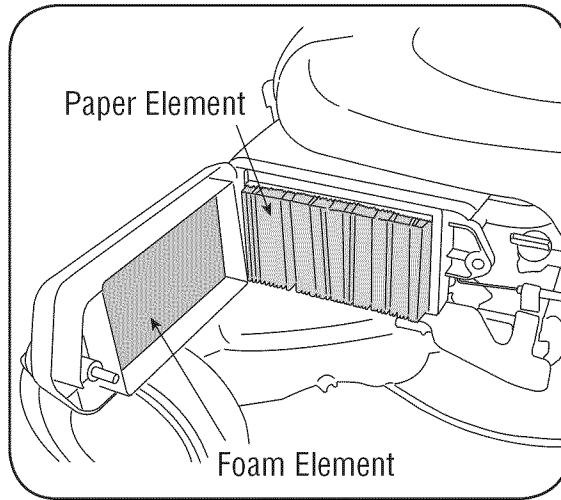

Figure 6

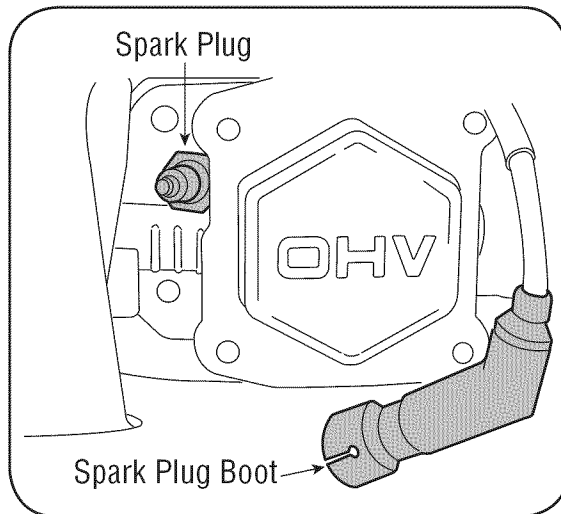

Figure 7



WARNING: If the engine has been running, the muffler will be very hot. Be careful not to touch the muffler.

2. Visually inspect the spark plug. Discard the spark plug if there is apparent wear, or if the insulator is cracked or chipped. Clean the spark plug with a wire brush if it is to be reused.
3. Measure the plug gap with a feeler gauge. Correct as necessary by bending side electrode. See Figure 8. The gap should be: 0.030 in.

10

Maintaining Your Engine



WARNING

Never use gasoline or low flash point solvents for cleaning the air cleaner element. A fire or explosion could result.

DO NOT check for spark with spark plug removed. DO NOT crank engine with spark plug removed.

If the engine has been running, the muffler will be very hot. Be careful not to touch the muffler.

10

Maintaining Your Engine



WARNING

Accumulation of debris around muffler could cause a fire. Inspect and clean before every use.



IMPORTANT

Do not spray engine with water to clean because water could contaminate fuel. Using a garden hose or pressure washing equipment can also force water into the air cleaner or muffler opening. Water in the air cleaner will soak the paper element, and water that passes through the element or muffler can enter the cylinder, causing

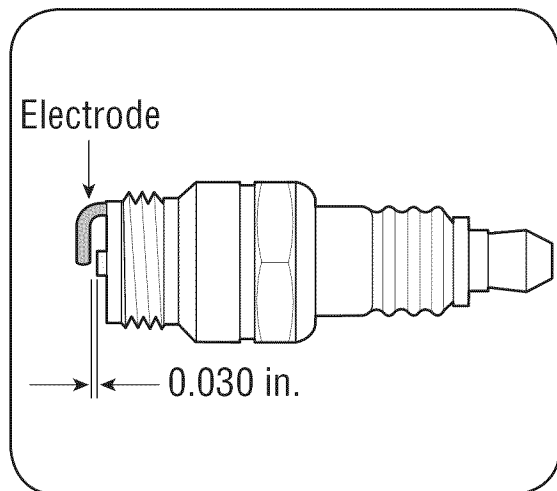

Figure 8

4. Check that the spark plug washer is in good condition and thread the spark plug in by hand to prevent cross-threading.
5. After the spark plug is seated, tighten with a spark plug wrench to compress the washer.

NOTE: When installing a new spark plug, tighten 1/2 turn after the spark plug seats to compress the washer. When reinstalling a used spark plug, tighten 1/8-1/4 turn after the spark plug seats to compress the washer.

IMPORTANT: The spark plug must be securely tightened. An improperly tightened spark plug can become very hot and may damage the engine.

Clean Engine

If the engine has been running, allow it to cool for at least half an hour before cleaning. Periodically remove grass and dirt build-up from engine. Clean finger guard and around muffler. Clean with a brush or compressed air.

IMPORTANT: Do not spray engine with water to clean because water could contaminate fuel. Using a garden hose or pressure washing equipment can also force water into the air cleaner or muffler opening. Water in the air cleaner will soak the paper element, and water that passes through the element or muffler can enter the cylinder, causing damage.



WARNING: Accumulation of debris around muffler could cause a fire. Inspect and clean before every use.

Storage

Engines stored over 30 days need to be drained of fuel to prevent deterioration and gum from forming in fuel system or on essential carburetor parts. If the gasoline in your engine deteriorates during storage, you may need to have the carburetor, and other fuel system components, serviced or replaced.

1. Remove all fuel from tank by running engine until it stops from lack of fuel.
2. Change oil. See Oil Change section.
3. Remove spark plug and pour about 1/2 an ounce of engine oil into cylinder. Replace spark plug and crank slowly to distribute oil.
4. Clean grass and debris from around engine, under finger guard, and under, around and behind muffler. Touch up any damaged paint, and coat other areas that may rust with a light film of oil.
5. Store in a clean, dry and well ventilated area away from any appliance that operates with a flame or pilot light, such as a furnace, water heater, or clothes dryer. Also avoid any area with a spark producing electric motor, or where power tools are operated.
6. If possible, also avoid storage areas with high humidity, because that promotes rust and corrosion.
7. Keep the engine level in storage. Tilting can cause fuel or oil leakage.

Removing From Storage

1. Check your engine as described in the Pre-Operation Check section of this manual.
2. If the fuel was drained during storage preparation, fill the tank with fresh gasoline. If you keep a container of gasoline for refueling, make certain it contains only fresh fuel. Gasoline oxidizes and deteriorates over time, causing hard starting.
3. If the cylinder was coated with oil during storage preparation, the engine will smoke briefly at startup. This is normal.

10

Maintaining Your Engine

Model 26M

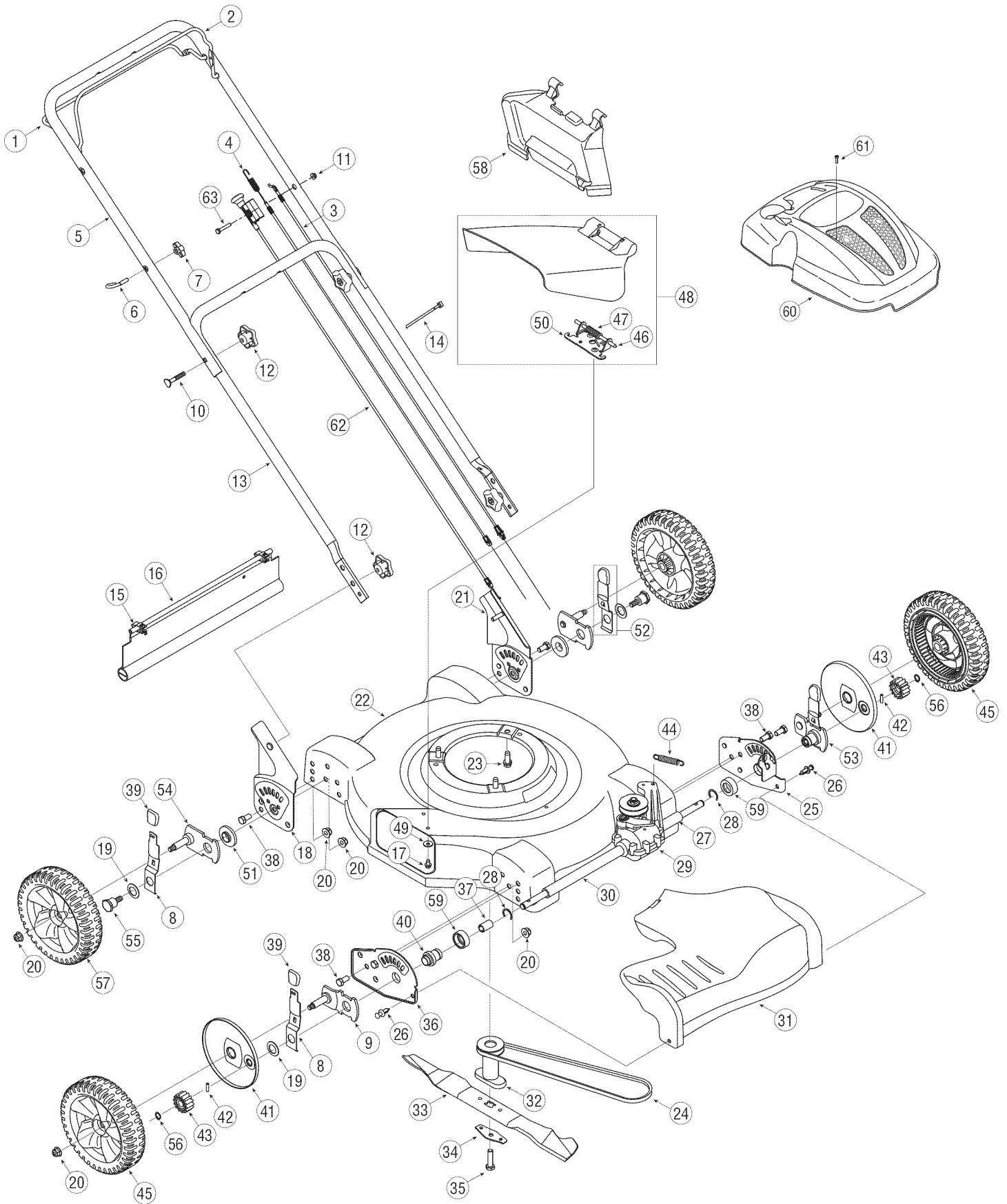

1.	747-1214	Drive Control
2.	747-1161A	Blade Control
3.	746-04300	Blade Control Cable
4.	746-04304	Drive Control Cable
5.	749-1092A	Upper Handle
6.	710-1205	Eye Bolt
7.	720-0279	Wing Nut, 1/4-20
8.	732-1026	Spring Lever
9.	687-02139	Pivot Arm Assembly
10.	710-1174	Carriage Bolt, 5/16-18 x 2.0
11.	712-04064	Flange Lock Nut, 1/4-20
12.	720-04072	Star Knob
13.	749-04037	Lower Handle
14.	725-0157	Cable Tie
15.	17098	Hinge Clip
16.	731-04019	Trail Shield
17.	710-0599	Hex Screw, 1/4-20 x.500
18.	682-3064	Handle Bracket Assy - RH
19.	736-0741	Bell Washer, .760 x 1.25 x.041
20.	712-04065	Lock Nut, 3/8-16
21.	682-3065	Handle Bracket Assembly - LH
22.	687-02046	22" Deck Assembly
23.	710-0654A	Hex Washer Scr., 3/8-16 x 1.0
24.	754-04100	V-Belt, 3L x 32.90
25.	782-0585A	Forward Height Adj. Plate - LH
26.	728-0199	Rivet
27.	750-04407	Sleeve Spacer, .550 ID x 2.22
28.	716-0198	Retainer Ring
29.	618-04375	Transmission Assy. Comp.
30.	750-04406A	Sleeve Spacer, .550 ID x 8.51
31.	731-04636	Transmission Cover
32.	748-04016A	Blade Adapter
33.	742-0742A	22" Mulching Blade

34.	736-0524B	Bell Blade Support
35.	710-1044	Hex Cap Screw, 3/8-24 x 1.5
36.	782-0584	Forward Hght. Adj. Plate - RH
37.	741-0710	Slv. Bearing, .502 x.627 x 1.00
38.	710-0216	Hex Cap Screw, 3/8-16 x.75
39.	720-0426	Adjustment Knob
40.	748-0455	Bearing Support
41.	731-04643	Wheel Dust Cover
42.	715-0221	Pin
43.	717-1762	Spur Gear 14T - RH
	717-1761	Spur Gear 14T - LH
44.	732-04049	Ext. Spring, .47 OD x 2.50
45.	634-04100	Front Wheel 8 x 1.8
46.	747-0710	Hinge Pin
47.	732-1014	Torsion Spring
48.	731-1034B	Side Discharge Assembly
49.	736-0270	Bell Washer, .265 ID x.75 OD
50.	17032A	Deflector Chute Adapter
51.	741-0751	Height Adjustment Bearing
52.	687-02051	Rear Hgt. Adj. Lever Assembly
53.	687-02140	Front Lever Assembly - LH
	687-02141	Front Lever Assembly - RH
54.	687-02094	Rear Pivot Arm Assembly
55.	738-1173	Shoulder Screw, 3/8-16
56.	716-0865	Snap Ring.500
57.	734-04087	Rear Wheel 8 x 1.8
58.	631-04045	Mulching Baffle
59.	748-0390	Bearing Support Spacer
60.	731-05401	Engine Shroud (Yellow)
61.	710-04577	Machine Screw, M4X.7
62.	746-04295	Choke Cable
63.	710-0606	Hex Screw, 1/4-20 x 1.50

11

Parts List



To order replacement parts, contact
1-800-800-7310
 or visit
www.mtdproducts.com.



IMPORTANT

For a proper working machine, use Factory Approved Parts. **V-BELTS** are specially designed to engage and disengage safely. A substitute (non OEM) V-Belt can be dangerous by not disengaging completely.

Engine 1P65

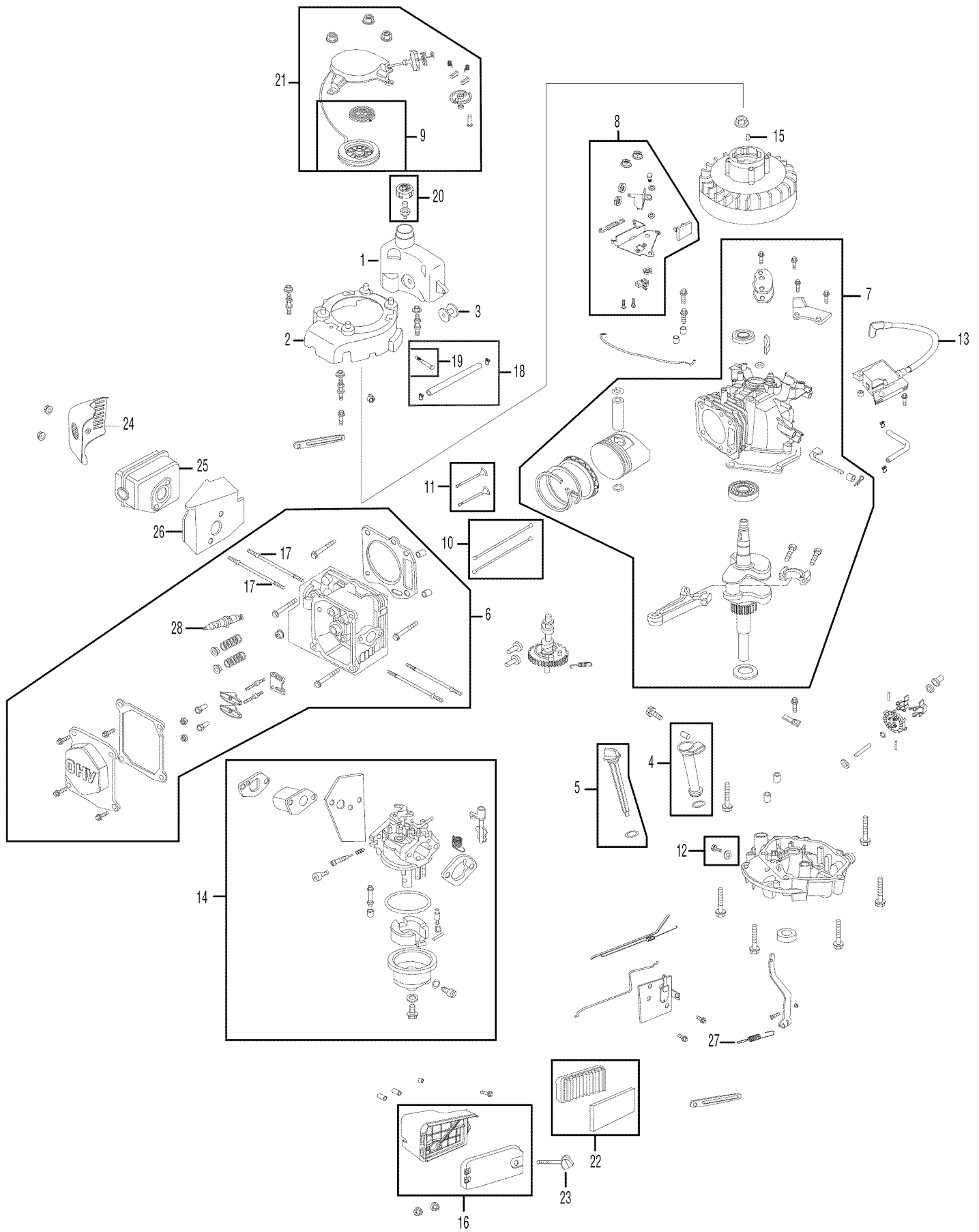

11

Illustrated Parts List

1.	951-10337	Fuel Tank
2.	951-10336	Flywheel Shroud
3.	951-10335	Rubber Fuel Tank Mounting Washer
4.	951-10334	Oil Filler Tube Assembly
5.	951-10333	Dipstick Assembly
6.	951-10406	Cylinder Head Complete
7.	951-10407	Short Block Assembly
8.	951-10320	Stop Switch and Brake Assembly
9.	951-10319	Recoil Spring and Pulley Assembly
10.	951-10314	Push Rod Kit
11.	951-10313	Valve Kit
12.	951-10370	Oil Drain Plug and Washer Assembly
13.	951-10367	Ignition Coil
14.	951-10309	Carburetor Assembly
15.	951-10307	Flywheel Key
16.	951-10405	Air Cleaner Housing Assembly Complete
17.	951-10304	Muffler Stud Assembly
18.	951-10363	Fuel Line Kit – Inc. hoses, clamps & filter
19.	951-10358	Fuel Filter
20.	951-10300	Fuel Cap Assembly
21.	951-10299	Recoil Starter Assembly
22.	951-10298	Air Cleaner Kit
23.	951-10297	Air Cleaner Thumb Screw
24.	951-10404	Muffler Guard
25.	951-10403	Muffler
26.	951-10402	Muffler Gasket /Heat Shield
27.	951-10293	Governor Return Spring
28.	951-10292	Spark Plug
–	952Z1P65FU	Engine – Complete
–	951-10325	Carburetor Kit – Major
–	951-10322	Carburetor Kit – Minor
–	951-10409	Gasket Kit – Complete
–	951-10410	Gasket Kit – External
–	951-10351	Spark Arrestor

NOTE: Illustrated parts without a numeric call-out are *not* servicable components.

MTD LLC (MTD), The United States Environment Protection Agency (U. S. EPA)

**Emission Control System Warranty Statement
(Owner's Defect Warranty Rights and Obligations)**

The U. S. EPA and MTD are pleased to explain the emissions control system warranty on your model year 2005 and later small off-road engine. New small off-road engines must be designed, built and equipped to meet the stringent anti-smog standards. MTD must warranty the emission control system on your engine for the period of time listed below, provided there has been no abuse, neglect or improper maintenance of your small off-road engine.

Your emission control system may include parts such as the carburetor, air cleaner, ignition system, exhaust system, and other associated emission-related components.

Where a warrantable condition exists, MTD will repair your small off-road engine at no cost to you including diagnosis, parts and labor.

MANUFACTURER'S WARRANTY COVERAGE:

This emissions control system is warranted for two years. If any emission-related part on your engine is defective, the part will be repaired or replaced by MTD.

OWNER'S WARRANTY RESPONSIBILITIES:

As the small off-road engine owner, you are responsible for the performance of the required maintenance listed in your Owner's Manual. MTD recommends that you retain all your receipts covering maintenances on your small off-road engine, but MTD can not deny warranty solely for the lack of receipts or for your failure to ensure the performance to all scheduled maintenance.

As the small off-road engine owner, you should however be aware that MTD may deny your warranty coverage if your small off-road engine or part has failed due to abuse, neglect, improper maintenance or unapproved modifications.

You are responsible for presenting your small off-road engine to an Authorized MTD Service Dealer as soon as a problem exists. The warranted repairs should be completed in a reasonable amount of time, not to exceed 30 days.

If you have any questions regarding your warranty rights and responsibilities, you should contact a MTD Service Representative at 1-800-800-7310 and address is MTD LLC, P.O. Box 361131, Cleveland OH, 44136-0019.

DEFECTS WARRANTY REQUIREMENTS FOR 1995 AND LATER SMALL OFF-ROAD ENGINES:

This section applies to 1995 and later small off-road engines. The warranty period begins on the date the engine or equipment is delivered to an ultimate purchaser.

(a) General Emissions Warranty Coverage

MTD must warrant to the ultimate purchaser and each subsequent purchaser that the engine is:

- (1) Designed, built, and equipped so as to conform with all applicable regulations adopted by the Air Resources Board pursuant to its authority in Chapters 1 and 2, Part 5, Division 26 of the Health and Safety Code; and
- (2) Free from defects in materials and workmanship that cause the failure of a warranted part to be identical in all material respects to the part as described in the engine manufacturer's application for certification for a period of two years.

(b) The warranty on emissions-related parts will be interpreted as follows:

- (1) Any warranted part that is not scheduled for replacement as required maintenance in the written instructions required by Subsection (c) must be warranted for the warranty period defined in Subsection (a)(2). If any such part fails during the period of warranty coverage, it must be repaired or replaced by MTD according to Subsection (4) below. Any such part repaired or replaced under the warranty must be warranted for the remaining warranty period.
- (2) Any warranted part that is scheduled only for regular inspection in the written instructions required by Subsection (c) must be warranted for the warranty period defined in Subsection (a)(2). A statement in such written instructions to the effect of "repair or replace as necessary" will not reduce the period of warranty coverage. Any such part repaired or replaced under warranty must be warranted for the remaining warranty period.
- (3) Any warranted part that which is scheduled for replacement as required maintenance in the written instructions required by Subsection (c) must be warranted for the period of time prior to the first scheduled replacement point for that part. If the part fails prior to the first scheduled replacement, the part must be repaired or replaced by MTD according to Subsection (4) below. Any such part repaired or replaced under warranty must be warranted for the remainder of the period prior to the first scheduled replacement point for the part.
- (4) Repair or replacement of any warranted part under the warranty provisions of this article must be performed at no charge to the owner at a warranty station.
- (5) Notwithstanding the provisions of Subsection (4) above, warranty services or repairs must be provided at all MTD distribution centers that are franchised to service the subject engines.
- (6) The owner must not be charged for diagnostic labor that leads to the determination that a warranted part is in fact defective, provided that such diagnostic work is performed at a warranty station.

(7) The engine manufacturer is liable for damages to other engine components proximately caused by a failure under warranty of any warranted part.

(8) Throughout the engine's warranty period defined in Subsection (a)(2), MTD will maintain a supply of warranted parts sufficient to meet the expected demand for such parts.

(9) Any replacement part may be used in the performance of any warranty maintenance or repairs and must be provided without charge to the owner. Such use will not reduce the warranty obligations of MTD.

(10) Add-on or modified parts that are not exempted by the Air Resources Board may not be used. The use of any non-exempted add-on or modified parts shall be grounds for disallowing a warranty claim made in accordance with this article. The engine manufacturer shall not be liable under this article to warrant failures of warranted parts caused by the use of non-exempted add-on or modified part.

(c) MTD will include a copy of the following emission warranty parts list with each new engine, using those portions of the list applicable to the engine.

(1) Fuel Metering System

- Cold start enrichment system (soft choke)
- Carburetor and internal parts
- Fuel Pump

(2) Air Induction System

- Air cleaner
- Intake manifold

(3) Ignition System

- Spark plug(s)
- Magneto Ignition System

(4) Exhaust System

(5) Miscellaneous Items Used in Above System

- Vacuum, temperature, position, time sensitive valves and switches
- Connectors and assemblies

MANUFACTURER'S LIMITED WARRANTY FOR



The limited warranty set forth below is given by MTD LLC with respect to new merchandise purchased and used in the United States, its possessions and territories.

"MTD" warrants this product against defects in material and workmanship for a period of two (2) years commencing on the date of original purchase and will, at its option, repair or replace, free of charge, any part found to be defective in materials or workmanship. This limited warranty shall only apply if this product has been operated and maintained in accordance with the Operator's Manual furnished with the product, and has not been subject to misuse, abuse, commercial use, neglect, accident, improper maintenance, alteration, vandalism, theft, fire, water, or damage because of other peril or natural disaster. Damage resulting from the installation or use of any part, accessory or attachment not approved by MTD for use with the product(s) covered by this manual will void your warranty as to any resulting damage.

Normal wear parts are warranted to be free from defects in material and workmanship for a period of thirty (30) days from the date of purchase. Normal wear parts include, but are not limited to items such as: batteries, belts, blades, blade adapters, grass bags, rider deck wheels, seats, snow thrower skid shoes, shave plates, auger spiral rubber and tires.

HOW TO OBTAIN SERVICE: Warranty service is available, WITH PROOF OF PURCHASE, through your local authorized service dealer. To locate the dealer in your area, check your Yellow Pages, or contact MTD LLC at P.O. Box 361131, Cleveland, Ohio 44136-0019, or call 1-800-800-7310 or log on to our Web site at www.mtdproducts.com.

This limited warranty does **not** provide coverage in the following cases:

- a. Log splitter pumps, valves, and cylinders have a separate one year warranty.
- b. Routine maintenance items such as lubricants, filters, blade sharpening, tune-ups, brake adjustments, clutch adjustments, deck adjustments, and normal deterioration of the exterior finish due to use or exposure.
- c. Service completed by someone other than an authorized service dealer.

- d. MTD does not extend any warranty for products sold or exported outside of the United States, its possessions and territories, except those sold through MTD's authorized channels of export distribution.
- e. Replacement parts that are not genuine MTD parts.
- f. Transportation charges and service calls.

No implied warranty, including any implied warranty of merchantability of fitness for a particular purpose, applies after the applicable period of express written warranty above as to the parts as identified. No other express warranty, whether written or oral, except as mentioned above, given by any person or entity, including a dealer or retailer, with respect to any product, shall bind MTD. During the period of the warranty, the exclusive remedy is repair or replacement of the product as set forth above.

The provisions as set forth in this warranty provide the sole and exclusive remedy arising from the sale. MTD shall not be liable for incidental or consequential loss or damage including, without limitation, expenses incurred for substitute or replacement lawn care services or for rental expenses to temporarily replace a warranted product.

Some states do not allow the exclusion or limitation of incidental or consequential damages, or limitations on how long an implied warranty lasts, so the above exclusions or limitations may not apply to you.

In no event shall recovery of any kind be greater than the amount of the purchase price of the product sold. **Alteration of safety features of the product shall void this warranty.** You assume the risk and liability for loss, damage, or injury to you and your property and/or to others and their property arising out of the misuse or inability to use the product.

This limited warranty shall not extend to anyone other than the original purchaser or to the person for whom it was purchased as a gift.

HOW STATE LAW RELATES TO THIS WARRANTY: This limited warranty gives you specific legal rights, and you may also have other rights which vary from state to state.

IMPORTANT: Owner must present Original Proof of Purchase to obtain warranty coverage.