

Owner's Manual

CRAFTSMAN®

LAWN TRACTOR

18.5 HP*, 42" Mower

Electric Start

6 Speed Transaxle

Model No.

917.273631

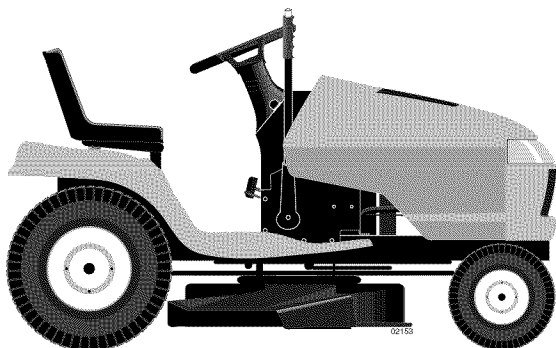

This product has a low emission engine which operates differently from previously built engines. Before you start the engine, read and understand this Owner's Manual.

IMPORTANT:

Read and follow all Safety Rules and Instructions before operating this equipment.

For answers to your questions about this product, Call:

1-800-659-5917
Sears Craftsman Help Line
5 am - 5 pm, Mon - Sat

Gasoline containing up to 10% ethanol (E10) is acceptable for use in this machine. The use of any gasoline exceeding 10% ethanol (E10) will void the product warranty.

Sears Brands Management Corporation, Hoffman Estates, IL 60179 U.S.A.
Visit our Craftsman website: www.sears.com/craftsman

*As rated by the engine manufacturer

191054 Rev. 4

TABLE OF CONTENTS

Warranty	2	Maintenance	17
Safety Rules	3	Service and Adjustments.....	21
Product Specifications	6	Storage	27
Assembly/Pre-Operation	8	Troubleshooting	28
Operation	11	Repair Parts.....	32
Maintenance Schedule	17	Sears Service	Back Cover

WARRANTY

Craftsman Riding Equipment Warranty

CRAFTSMAN FULL WARRANTY

FOR TWO YEARS from the date of purchase, all non-expendable parts of this riding equipment are warranted against any defects in material or workmanship. A defective non-expendable part will receive free in-home repair or replacement if repair is impossible.

FOR FIVE YEARS from the date of purchase, the frame and front axle of this riding equipment are warranted against any defects in material or workmanship. A defective frame or front axle will receive free in-home repair or replacement if repair is impossible.

FOR 90 DAYS from the date of purchase, the battery (an expendable part) of this riding equipment is warranted against any defects in material or workmanship (our testing proves that it will not hold a charge). A defective battery will receive free in-home replacement.

ADDITIONAL LIFETIME LIMITED WARRANTY on CAST IRON FRONT AXLE (if equipped)

FOR AS LONG AS IT IS USED by the original owner after the fifth year from the date of purchase, the cast iron front axle (if equipped) of this riding equipment is warranted against any defects in material or workmanship. With proof of purchase, a defective cast front axle will receive free in-home replacement.

WARRANTY SERVICE

For warranty coverage details to obtain free repair or replacement, call 1-800-659-5917 or visit the web site: www.craftsman.com

In all cases above, if part repair or replacement is impossible, the riding equipment will be replaced free of charge with the same or an equivalent model.

All of the above warranty coverage is void if this riding equipment is ever used while providing commercial services or if rented to another person.

This warranty covers ONLY defects in material and workmanship. Warranty coverage does NOT include:

- Expendable parts (except battery) that can wear out from normal use within the warranty period, including but not limited to blades, spark plugs, air cleaners, belts, and oil filters.
- Standard maintenance servicing, oil changes, or tune-ups.
- Tire replacement or repair caused by punctures from outside objects, such as nails, thorns, stumps, or glass.
- Tire or wheel replacement or repair resulting from normal wear, accident, or improper operation or maintenance.
- Repairs necessary because of operator abuse, including but not limited to damage caused by towing objects beyond the capability of the riding equipment, impacting objects that bend the frame, axle assembly or crankshaft, or over-speeding the engine.
- Repairs necessary because of operator negligence, including but not limited to, electrical and mechanical damage caused by improper storage, failure to use the proper grade and amount of engine oil, failure to keep the deck clear of flammable debris, or failure to maintain the riding equipment according to the instructions contained in the operator's manual.
- Engine (fuel system) cleaning or repairs caused by fuel determined to be contaminated or oxidized (stale). In general, fuel should be used within 30 days of its purchase date.
- Normal deterioration and wear of the exterior finishes, or product label replacement.

This warranty gives you specific legal rights, and you may also have other rights which vary from state to state.

Sears Brands Management Corporation, Hoffman Estates, IL 60179

SAFETY RULES

IMPORTANT: This cutting machine is capable of amputating hands and feet and throwing objects. Failure to observe the following safety instructions could result in serious injury or death.

⚠️WARNING: In order to prevent accidental starting when setting up, transporting, adjusting or making repairs, always disconnect spark plug wire and place wire where it cannot contact spark plug.

⚠️WARNING: Do not coast down a hill in neutral, you may lose control of the tractor.

⚠️WARNING: Tow only the attachments that are recommended by and comply with specifications of the manufacturer of your tractor. Use common sense when towing. Operate only at the lowest possible speed when on a slope. Too heavy of a load, while on a slope, is dangerous. Tires can lose traction with the ground and cause you to lose control of your tractor.

⚠️WARNING: Engine exhaust, some of its constituents, and certain vehicle components contain or emit chemicals known to the State of California to cause cancer and birth defects or other reproductive harm.

⚠️WARNING: Battery posts, terminals and related accessories contain lead and lead compounds, chemicals known to the State of California to cause cancer and birth defects or other reproductive harm.

Wash hands after handling.

I. GENERAL OPERATION

- Read, understand, and follow all instructions in the manual and on the machine before starting.
- Only allow responsible adults, who are familiar with the instructions, to operate the machine.
- Clear the area of objects such as rocks, toys, wire, etc., which could be picked up and thrown by the blade.
- Be sure the area is clear of other people before mowing. Stop machine if anyone enters the area.
- Never carry passengers.
- Do not mow in reverse unless absolutely necessary. Always look down and behind before and while backing.

- Be aware of the mower discharge direction and do not point it at anyone. Do not operate the mower without either the entire grass catcher or the guard in place.
- Slow down before turning.
- Never leave a running machine unattended. Always turn off blades, set parking brake, stop engine, and remove keys before dismounting.
- Turn off blades when not mowing.
- Stop engine before removing grass catcher or unclogging chute.
- Mow only in daylight or good artificial light.
- Do not operate the machine while under the influence of alcohol or drugs.
- Watch for traffic when operating near or crossing roadways.
- Use extra care when loading or unloading the machine into a trailer or truck.
- Data indicates that operators, age 60 years and above, are involved in a large percentage of riding mower-related injuries. These operators should evaluate their ability to operate the riding mower safely enough to protect themselves and others from serious injury.
- Keep machine free of grass, leaves or other debris build-up which can touch hot exhaust / engine parts and burn. Do not allow the mower deck to plow leaves or other debris which can cause build-up to occur. Clean any oil or fuel spillage before operating or storing the machine. Allow machine to cool before storage.

II. SLOPE OPERATION

Slopes are a major factor related to loss-of-control and tipover accidents, which can result in severe injury or death. All slopes require extra caution. If you cannot back up the slope or if you feel uneasy on it, do not mow it.

SAFETY RULES

DO:

- Mow up and down slopes, not across.
- Remove obstacles such as rocks, tree limbs, etc.
- Watch for holes, ruts, or bumps. Uneven terrain could overturn the machine. *Tall grass can hide obstacles.*
- Use slow speed. Choose a low gear so that you will not have to stop or shift while on the slope.
- Follow the manufacturer's recommendations for wheel weights or counterweights to improve stability.
- Use extra care with grass catchers or other attachments. These can change the stability of the machine.
- Keep all movement on the slopes *slow* and *gradual*. Do not make sudden changes in speed or direction.
- Avoid starting or stopping on a slope. If tires lose traction, disengage the blades and proceed slowly *straight* down the slope.

DO NOT:

- *Do not* turn on slopes unless necessary, and then, turn slowly and gradually downhill, if possible.
- *Do not* mow near drop-offs, ditches, or embankments. The mower could suddenly turn over if a wheel is over the edge of a cliff or ditch, or if an edge caves in.
- *Do not* mow on wet grass. Reduced traction could cause sliding.
- *Do not* try to stabilize the machine by putting your foot on the ground.
- *Do not* use grass catcher on steep slopes.

III. CHILDREN

Tragic accidents can occur if the operator is not alert to the presence of children. Children are often attracted to the machine and the mowing activity. *Never* assume that children will remain where you last saw them.

- Keep children out of the mowing area and under the watchful care of another responsible adult.
- Be alert and turn machine off if children enter the area.
- Before and when backing, look behind and *down* for small children.

- Never carry children. They may fall off and be seriously injured or interfere with safe machine operation.
- Never allow children to operate the machine.
- Use extra care when approaching blind corners, shrubs, trees, or other objects that may obscure vision.

IV. SERVICE

- Use extra care in handling gasoline and other fuels. They are flammable and vapors are explosive.
 - Use only an approved container.
 - Never remove gas cap or add fuel with the engine running. Allow engine to cool before refueling. Do not smoke.
 - Never refuel the machine indoors.
 - Never store the machine or fuel container inside where there is an open flame, such as a water heater.
- Never run a machine inside a closed area.
- Keep nuts and bolts, especially blade attachment bolts, tight and keep equipment in good condition.
- Never tamper with safety devices. Check their proper operation regularly.
- Keep machine free of grass, leaves, or other debris build-up. Clean oil or fuel spillage. Allow machine to cool before storing.
- Stop and inspect the equipment if you strike an object. Repair, if necessary, before restarting.
- Never make adjustments or repairs with the engine running.
- Grass catcher components are subject to wear, damage, and deterioration, which could expose moving parts or allow objects to be thrown. Frequently check components and replace with manufacturer's recommended parts, when necessary.
- Mower blades are sharp and can cut. Wrap the blade(s) or wear gloves, and use extra caution when servicing them.
- Check brake operation frequently. Adjust and service as required.

SAFETY RULES



- Be sure the area is clear of other people before mowing. Stop machine if anyone enters the area.
- Never carry passengers or children even with the blades off.
- Do not mow in reverse unless absolutely necessary. Always look down and behind before and while backing.
- Never carry children. They may fall off and be seriously injured or interfere with safe machine operation.
- Keep children out of the mowing area and under the watchful care of another responsible adult.
- Be alert and turn machine off if children enter the area.
- Before and when backing, look behind and down for small children.
- Mow up and down slopes (15° Max), not across.
- Remove obstacles such as rocks, tree limbs, etc.
- Watch for holes, ruts, or bumps. Uneven terrain could overturn the machine. Tall grass can hide obstacles.
- Use slow speed. Choose a low gear so that you will not have to stop or shift while on the slope.
- Avoid starting or stopping on a slope. If tires lose traction, disengage the blades and proceed slowly straight down the slope.
- If machine stops while going uphill, disengage blades, shift into reverse and back down slowly.
- Do not turn on slopes unless necessary, and then, turn slowly and gradually downhill, if possible.

PRODUCT SPECIFICATIONS

Gasoline	4.0	
Capacity and Type:	Unleaded Regular	
Oil Type (API-SG-SL):	SAE 30 (above 32°F) SAE 5W-30(below 32°F)	
Oil Capacity:	W/Filter:	3.5 Pints
	W/O Filter:	3.0 Pints
Spark Plug: (Gap: .030")	Champion RC12YC	
Ground Speed (MPH):	Forward:	
	1st	1.2
	2nd	1.6
	3rd	2.4
	4th	3.6
	5th	4.6
	6th	5.9
	Reverse:	1.8
Tire Pressure:	Front:	14 PSI
	Rear:	10 PSI
Charging System:	9 Amps @3600 RPM	
Battery:	Amp/Hr:	28
	Min. CCA:	230
	Case Size:	U1R
Blade Bolt Torque:	27-35 Ft. Lbs.	

CONGRATULATIONS on your purchase of a new tractor. It has been designed, engineered and manufactured to give you the best possible dependability and performance. Should you experience any problem you cannot easily remedy, please contact a Sears or other qualified service center. We have competent, well-trained technicians and the proper tools to service or repair this tractor.

Please read and retain this manual. The instructions will enable you to assemble and maintain your tractor properly. Always observe the "SAFETY RULES".

CUSTOMER RESPONSIBILITIES

- Read and observe the safety rules.
- Follow a regular schedule in maintaining, caring for and using your tractor.
- Follow the instructions under "Maintenance" and "Storage" sections of this owner's manual.

⚠️ WARNING: This tractor is equipped with an internal combustion engine and should not be used on or near any unimproved forest-covered, brush-covered or grass-covered land unless the engine's exhaust system is equipped with a spark arrester meeting applicable local or state laws (if any). If a spark arrester is used, it should be maintained in effective working order by the operator.

In the state of California the above is required by law (Section 4442 of the California Public Resources Code). Other states may have similar laws. Federal laws apply on federal lands. A spark arrester for the muffler is available through your nearest Sears service center (See REPAIR PARTS section of this manual).

REPAIR PROTECTION AGREEMENTS

Congratulations on making a smart purchase. Your new Craftsman® product is designed and manufactured for years of dependable operation. But like all products, it may require repair from time to time. That's when having a Repair Protection Agreement can save you money and aggravation. *Purchase a Repair Protection Agreement now and protect yourself from unexpected hassle and expense.*

Here's what's included in the Agreement:

- Expert service by our 12,000 professional repair specialists.
- Unlimited service and no charge for parts and labor on all covered repairs.
- Product replacement if your covered product can't be fixed.
- Discount of 10% from regular price of service and service-related parts not covered by the agreement; also, 10% off regular price of preventive maintenance check.
- Fast help by phone – phone support from a Sears technician on products requiring in-home repair, plus convenient repair scheduling.

Once you purchase the Agreement, a simple phone call is all that it takes for you to schedule service. You can call anytime day or night, or schedule a service appointment online.

Sears has over 12,000 professional repair specialists, who have access to over 4.5 million quality parts and accessories. That's the kind of professionalism you can count on to help prolong the life of your new purchase for years to come. Purchase your Repair Protection Agreement today! **Some limitations and exclusions apply. For prices and additional information call 1-800-827-6655.**

SEARS INSTALLATION SERVICE

For Sears professional installation of home appliances, garage door openers, water heaters, and other major home items, in the U.S.A. call **1-800-4-MY-HOME®**

UNASSEMBLED PARTS

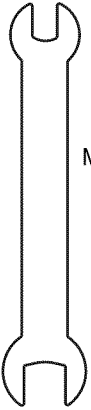

Mower Leveling Wrench

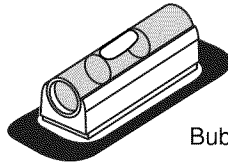

Bubble Level



(1) Oil Drain Tube
For Future Use

Keys

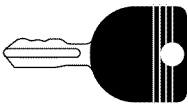

(2) Keys

Slope Sheet

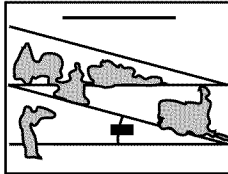

Video Cassette

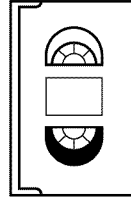

ASSEMBLY/PRE-OPERATION

Your new tractor has been assembled at the factory. Review the video cassette before you begin.

When right or left hand is mentioned in this manual, it means when you are in the operating position (seated behind the steering wheel).

TO REMOVE TRACTOR FROM CARTON

UNPACK CARTON

1. Cut along dotted lines on all four panels of carton. Remove end panels and lay side panels flat.
2. Remove protective materials from tractor hood and grille.

IMPORTANT: Check for and remove any staples in skid that may puncture tires where tractor is to roll off skid.

HOW TO SET UP YOUR TRACTOR

CHECK BATTERY

1. Lift hood to raised position.

NOTE: If this battery is put into service after month and year indicated on label (label located between terminals) charge battery for minimum of one hour at 6-10 amps. (See "BATTERY" in Maintenance section of this manual for charging instructions).

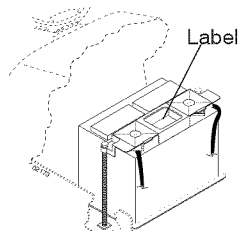

ADJUST SEAT

1. Raise seat and loosen adjustment knob.
2. Lower seat into operating position and sit in seat.
3. Slide seat until a comfortable position is reached which allows you to press clutch/brake pedal all the way down.
4. Get off seat without moving its adjusted position.
5. Raise seat and tighten adjustment knob securely.

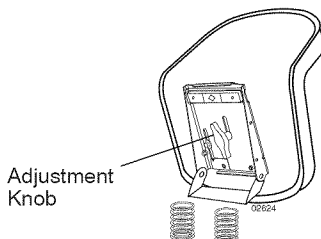

NOTE: You may now roll or drive your tractor off the skid. Follow the appropriate instruction below to remove the tractor from the skid.

TO ROLL TRACTOR OFF SKID (See Operation section for location and function of controls)

1. Press lift lever plunger and raise attachment lift lever to its highest position.
2. Release parking brake by depressing clutch/brake pedal.
3. Place gearshift lever in neutral (N) position.
4. Roll tractor forward off skid.
5. Remove banding holding deflector shield up against tractor.

TO DRIVE TRACTOR OFF SKID (See Operation section for location and function of controls)

⚠WARNING: Before starting, read, understand and follow all instructions in the Operation section of this manual. Be sure tractor is in a well-ventilated area. Be sure the area in front of tractor is clear of other people and objects.

1. Be sure all the above assembly steps have been completed.
2. Check engine oil level and fill fuel tank with gasoline.
3. Sit on seat in operating position, depress clutch/brake pedal and set the parking brake.
4. Place gear shift lever in neutral (N) position.
5. Press lift lever plunger and raise attachment lift lever to its highest position.

6. Start the engine. After engine has started, move throttle control to idle position.
7. Depress clutch/brake pedal into full "BRAKE" position and hold. Move gearshift lever to 1st gear.
8. Slowly release clutch/brake pedal and slowly drive tractor off skid.
9. Apply brake to stop tractor, set parking brake and place gearshift lever in neutral position.
10. Turn ignition key to "STOP" position. Continue with the instructions that follow.

REPOSITION RIGHT REAR GAUGE WHEEL

For shipping purposes, the right rear gauge wheel assembly is mounted upside down on the mower. Remove the gauge wheel assembly and reinstall from the bottom as shown. To adjust gauge wheels, see the Operation section in this manual.

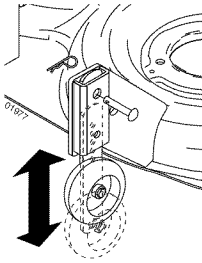

INSTALL MULCHER PLATE (If previously removed)

1. Raise and hold deflector shield in upright position.
2. Place front of mulcher plate over front of mower deck opening and slide into place, as shown.
3. Hook front latch into hole on front of mower deck.
4. Hook rear latch into hole on back of mower deck.

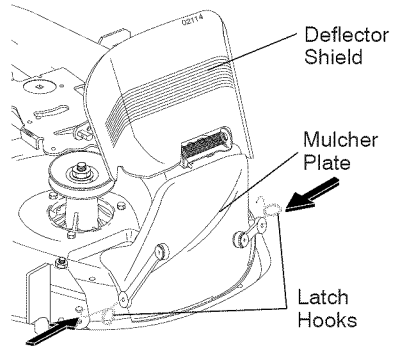

CAUTION: Do not remove deflector shield from mower.

TO CONVERT TO BAGGING OR DISCHARGING

Simply remove mulcher plate and store in a safe place. Your mower is now ready for discharging or installation of optional grass catcher accessory.

NOTE: It is not necessary to change blades. The mulcher blades are designed for discharging and bagging also.

CHECK TIRE PRESSURE

The tires on your tractor were overinflated at the factory for shipping purposes. Correct tire pressure is important for best cutting performance.

- Reduce tire pressure to PSI shown in “PRODUCT SPECIFICATIONS” section of this manual.

CHECK DECK LEVELNESS

For best cutting results, mower housing should be properly leveled. See “TO LEVEL MOWER HOUSING” in the Service and Adjustments section of this manual.

CHECK FOR PROPER POSITION OF ALL BELTS

See the figures that are shown for replacing motion and mower blade drive belts in the Service and Adjustments section of this manual. Verify that the belts are routed correctly.

CHECK BRAKE SYSTEM

After you learn how to operate your tractor, check to see that the brake is properly adjusted. See “TO ADJUST BRAKE” in the Service and Adjustments section of this manual.

✓CHECKLIST

Before you operate and enjoy your new tractor, we wish to assure that you receive the best performance and satisfaction from this Quality Product.

Please review the following checklist:

- ✓ All assembly instructions have been completed.
- ✓ No remaining loose parts in carton.
- ✓ Battery is properly prepared and charged. (Minimum 1 hour at 6 amps).
- ✓ Seat is adjusted comfortably and tightened securely.
- ✓ All tires are properly inflated. (For shipping purposes, the tires were overinflated at the factory).
- ✓ Be sure mower deck is properly leveled side-to-side/front-to-rear for best cutting results. (Tires must be properly inflated for leveling).
- ✓ Check mower and drive belts. Be sure they are routed properly around pulleys and inside all belt keepers.
- ✓ Check wiring. See that all connections are still secure and wires are properly clamped.

While learning how to use your tractor, pay extra attention to the following important items:

- ✓ Engine oil is at proper level.
- ✓ Fuel tank is filled with fresh, clean, regular unleaded gasoline.
- ✓ Become familiar with all controls - their location and function. Operate them before you start the engine.
- ✓ Be sure brake system is in safe operating condition.

OPERATION

These symbols may appear on your tractor or in literature supplied with the product. Learn and understand their meaning.

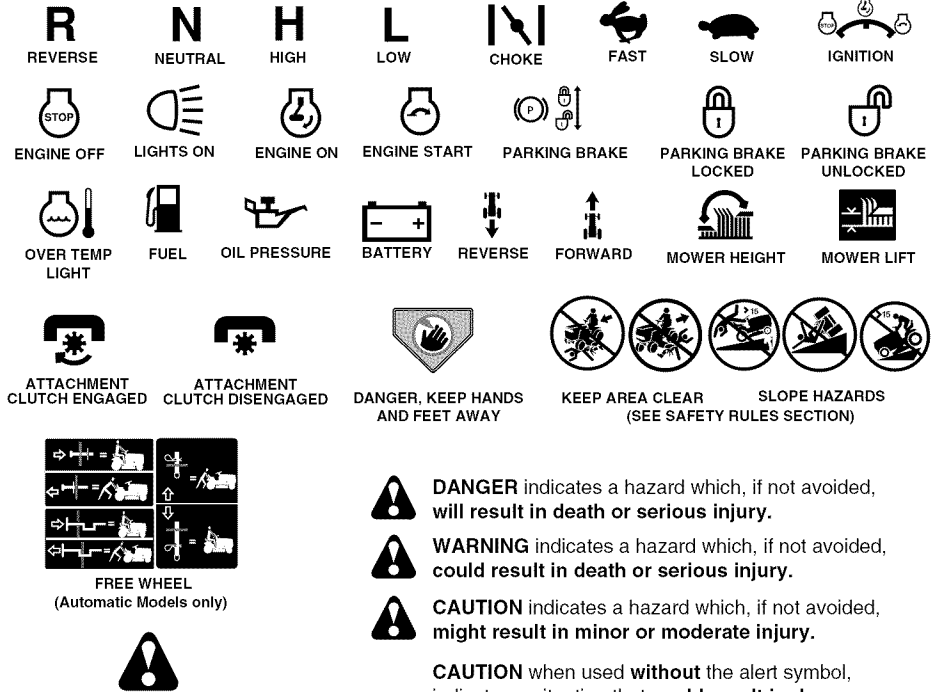

Failure to follow instructions could result in serious injury or death. The safety alert symbol is used to identify safety information about hazards which can result in death, serious injury and/or property damage.



DANGER indicates a hazard which, if not avoided, will result in death or serious injury.



WARNING indicates a hazard which, if not avoided, could result in death or serious injury.



CAUTION indicates a hazard which, if not avoided, might result in minor or moderate injury.

CAUTION when used **without** the alert symbol, indicates a situation that **could result in damage to the tractor and/or engine**.



HOT SURFACES indicates a hazard which, if not avoided, could result in death, serious injury and/or property damage.



FIRE indicates a hazard which, if not avoided, could result in death, serious injury and/or property damage.

KNOW YOUR TRACTOR

READ THIS OWNER'S MANUAL AND SAFETY RULES BEFORE OPERATING YOUR TRACTOR

Compare the illustrations with your tractor to familiarize yourself with the locations of various controls and adjustments. Save this manual for future reference.

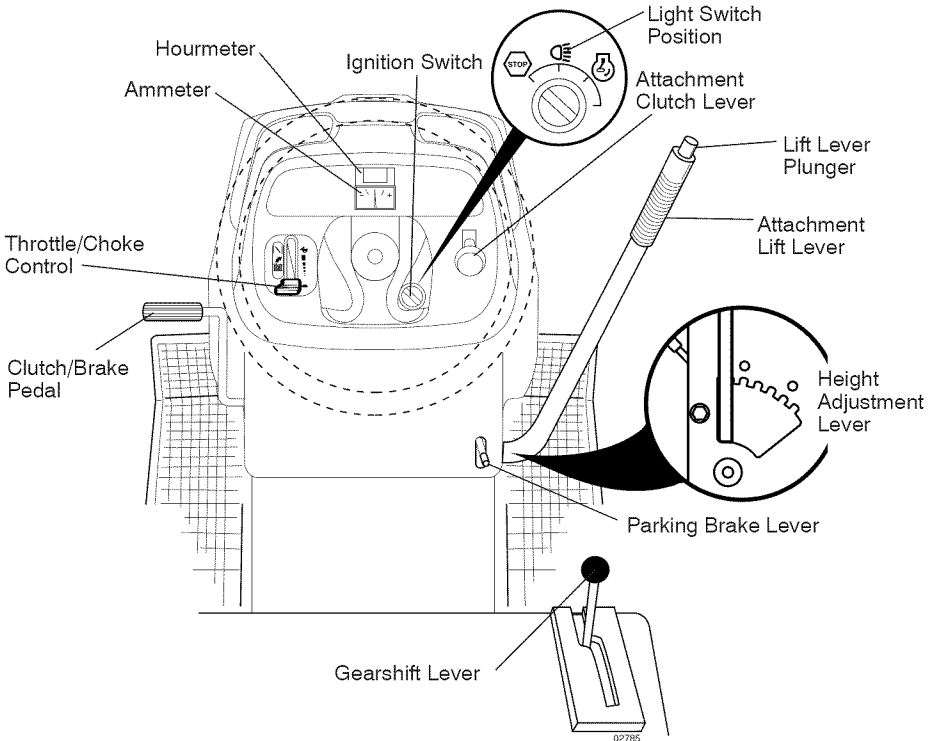

Our tractors conform to the safety standards of the American National Standards Institute.

AMMETER - Indicates charging (+) or discharging (-) of battery.

ATTACHMENT CLUTCH LEVER - Used to engage the mower blades, or other attachments mounted to your tractor.

ATTACHMENT LIFT LEVER - Used to raise, lower, and adjust the mower deck or other attachments mounted to your tractor.

CLUTCH/BRAKE PEDAL - Used for declutching and braking the tractor and starting the engine.

GEARSHIFT LEVER - Selects the speed and direction of tractor.

IGNITION SWITCH - Used for starting and stopping the engine.

LIFT LEVER PLUNGER - Used to release attachment lift lever when changing its position.

LIGHT SWITCH POSITION - Turns the headlights on and off.

PARKING BRAKE LEVER - Locks clutch/brake pedal into the brake position.

THROTTLE/CHOKE CONTROL - Used for starting and controlling engine speed.

HOURMETER - Indicates hours of operation.



The operation of any tractor can result in foreign objects thrown into the eyes, which can result in severe eye damage. Always wear safety glasses or eye shields while operating your tractor or performing any adjustments or repairs. We recommend a wide vision safety mask over spectacles or standard safety glasses.

HOW TO USE YOUR TRACTOR TO SET PARKING BRAKE

Your tractor is equipped with an operator presence sensing switch. When engine is running, any attempt by the operator to leave the seat without first setting the parking brake will shut off the engine.

1. Depress clutch/brake pedal all the way down and hold.
2. Pull parking brake lever up and release pressure from clutch/brake pedal. Pedal should remain in brake position. Make sure parking brake will hold tractor secure.

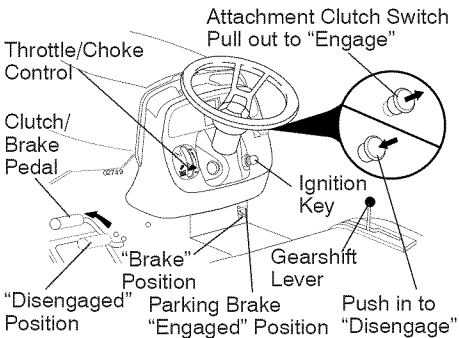

STOPPING

MOWER BLADES -

- To stop mower blades, push attachment clutch switch in to disengaged position.

GROUND DRIVE -

- To stop ground drive, depress clutch/brake pedal all the way down.
- Move gearshift lever to neutral (N) position.

ENGINE -

- Move throttle control to slow position.
- NOTE:** Failure to move throttle control to slow position to allow engine to idle before stopping may cause engine to "backfire".
- Turn ignition key to "STOP" position and remove key. Always remove key when leaving tractor to prevent unauthorized use.
 - Never use choke to stop engine.

IMPORTANT: Leaving the ignition switch in any position other than "STOP" will cause the battery to discharge and go dead.

NOTE: Under certain conditions when tractor is standing idle with the engine running, hot engine exhaust gases may cause "browning" of grass. To eliminate this possibility, always stop engine when stopping tractor on grass areas.

CAUTION: Always stop tractor completely, as described above, before leaving the operator's position.

TO USE THROTTLE CONTROL

Always operate engine at full throttle.

- Operating engine at less than full throttle reduces the battery charging rate.
- Full throttle offers the best bagging and mower performance.

TO MOVE FORWARD AND BACKWARD

The direction and speed of movement is controlled by the gearshift lever.

1. Start tractor with clutch/brake pedal depressed and gearshift lever in neutral (N) position.
2. Move gearshift lever to desired position.
3. Slowly release clutch/brake pedal to start movement.

IMPORTANT: Bring tractor to a complete stop before shifting or changing gears. Failure to do so will shorten the useful life of your transaxle.

TO ADJUST MOWER CUTTING HEIGHT

The position of the attachment lift lever determines the cutting height.

- Grasp lift lever.
- Press plunger with thumb and move lever to desired position.

The cutting height range is approximately 1-1/2 to 4". The heights are measured from the ground to the blade tip with the engine not running. These heights are approximate and may vary depending upon soil conditions, height of grass and types of grass being mowed.

- The average lawn should be cut to approximately 2-1/2 inches during the cool season and to over 3 inches during hot months. For healthier and better looking lawns, mow often and after moderate growth.

- For best cutting performance, grass over 6 inches in height should be mowed twice. Make the first cut relatively high; the second to desired height.

TO ADJUST GAUGE WHEELS

Gauge wheels are properly adjusted when they are slightly off the ground when mower is at the desired cutting height in operating position. Gauge wheels then keep the deck in proper position to help prevent scalping in most terrain conditions.

NOTE: Be sure tractor is on a flat level surface.

1. Lower mower and adjust mower to desired cutting height (See "TO ADJUST MOWER CUTTING HEIGHT" in this section of manual).
2. Remove retainer spring and clevis pin which secure each gauge wheel bar.
3. Lower gauge wheels to ground. Raise gauge wheels slightly to align holes in bracket and gauge wheel bar and insert clevis pin. Gauge wheels should be slightly off the ground.
4. Replace retainer spring into clevis pin.
5. Be sure all gauge wheels are in the same setting.

IMPORTANT: Be sure to readjust gauge wheels if you change the cutting height of the mower deck.

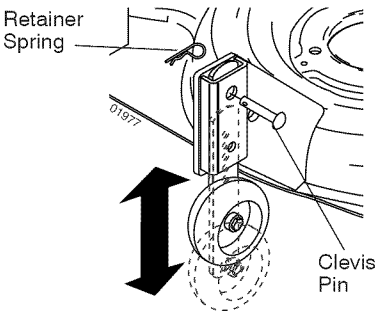

TO OPERATE MOWER

Your tractor is equipped with an operator presence sensing switch. Any attempt by the operator to leave the seat with the engine running and the attachment clutch engaged will shut off the engine. You must remain fully and centrally positioned in the seat to prevent the engine from hesitating or cutting off when operating your equipment on rough, rolling terrain or hills.

1. Select desired height of cut.
2. Start mower blades by engaging attachment clutch control.

TO STOP MOWER BLADES - disengage attachment clutch control.

CAUTION: Do not operate the mower without either the entire grass catcher, on mowers so equipped, or the deflector shield in place.

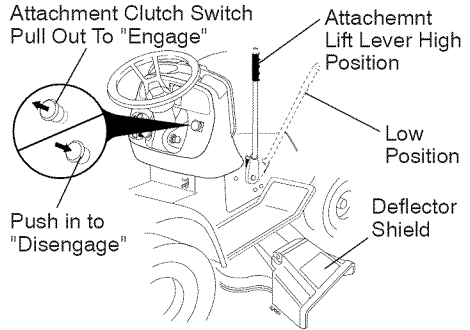

TO OPERATE ON HILLS

WARNING: Do not drive up or down hills with slopes greater than 15° and do not drive across any slope. Use the slope guide at the back of this manual.

- Choose the slowest speed before starting up or down hills.
- Avoid stopping or changing speed on hills.
- If slowing is necessary, move throttle control lever to slower position.
- If stopping is absolutely necessary, push clutch/brake pedal quickly to brake position and engage parking brake.
- Move gearshift lever to 1st gear. Be sure you have allowed room for tractor to roll slightly as you restart movement.
- To restart movement, slowly release parking brake and clutch/brake pedal.
- Make all turns slowly.

TO TRANSPORT

- Raise attachment lift to highest position with attachment lift control.
- When pushing or towing your tractor, be sure gearshift lever is in neutral (N) position.
- Do not push or tow tractor at more than five (5) MPH.

NOTE: To protect hood from damage when transporting your tractor on a truck or a trailer, be sure hood is closed and secured to tractor. Use an appropriate means of tying hood to tractor (rope, cord, etc.).

TOWING CARTS AND OTHER ATTACHMENTS

Tow only the attachments that are recommended by and comply with specifications of the manufacturer of your tractor. Use common sense when towing. Too heavy of a load, while on a slope, is dangerous. Tires can lose traction with the ground and cause you to lose control of your tractor.

BEFORE STARTING THE ENGINE CHECK ENGINE OIL LEVEL

The engine in your tractor has been shipped, from the factory, already filled with summer weight oil.

1. Check engine oil with tractor on level ground.
 2. Remove oil fill cap/dipstick and wipe clean, reinsert the dipstick and screw cap tight, wait for a few seconds, remove and read oil level. If necessary, add oil until "FULL" mark on dipstick is reached. Do not overfill.
- For cold weather operation you should change oil for easier starting (See the oil viscosity chart in the Maintenance section of this manual).
 - To change engine oil, see the Maintenance section in this manual.

ADD GASOLINE

- Fill fuel tank to bottom of filler neck. Do not overfill. Use fresh, clean, regular unleaded gasoline with a minimum of 87 octane. (Use of leaded gasoline will increase carbon and lead oxide deposits and reduce valve life). Do not mix oil with gasoline. Purchase fuel in quantities that can be used within 30 days to assure fuel freshness.

⚠ CAUTION: Wipe off any spilled oil or fuel. Do not store, spill or use gasoline near an open flame.

IMPORTANT: When operating in temperatures below 32°F (0°C), use fresh, clean winter grade gasoline to help insure good cold weather starting.

CAUTION: Alcohol blended fuels (called gasohol or using ethanol or methanol) can attract moisture which leads to separation and formation of acids during storage.

Acidic gas can damage the fuel system of an engine while in storage. To avoid engine problems, the fuel system should be emptied before storage of 30 days or longer. Drain the gas tank, start the engine and let it run until the fuel lines and carburetor are empty. Use fresh fuel next season. See Storage Instructions for additional information. Never use engine or carburetor cleaner products in the fuel tank or permanent damage may occur.

TO START ENGINE

When starting the engine for the first time or if the engine has run out of fuel, it will take extra cranking time to move fuel from the tank to the engine.

1. Sit on seat in operating position, depress clutch/brake pedal and set parking brake.
2. Place gear shift lever in neutral (N) position.
3. Move attachment clutch to disengaged position.
4. Move throttle control to choke position.

NOTE: Before starting, read the warm and cold starting procedures below.

5. Insert key into ignition and turn key clockwise to start position and release key as soon as engine starts. Do not run starter continuously for more than fifteen seconds per minute. If the engine does not start after several attempts, move throttle control to fast position, wait a few minutes and try again. If engine still does not start, move the throttle control back to the choke position and retry.

WARM WEATHER STARTING (50° F and above)

6. When engine starts, move the throttle control to the fast position.
- The attachments and ground drive can now be used. If the engine does not accept the load, restart the engine and allow it to warm up for one minute using the choke as described above.

COLD WEATHER STARTING (50° F and below)

6. When engine starts, leave throttle control in choke position until engine warms up and begins to run roughly. Once rough running begins, immediately move the throttle control to the fast position. Engine warm-up may take from several seconds to several minutes (the colder the temperature, the longer the warm-up).

- The attachments can also be used during the engine warm-up period.

NOTE: If at a high altitude (above 3000 feet) or in cold temperatures (below 32 F) the carburetor fuel mixture may need to be adjusted for best engine performance (see “TO ADJUST CARBURETOR” in the Service and Adjustments section of this manual).

MOWING TIPS

- Mower should be properly leveled for best mowing performance. See “TO LEVEL MOWER HOUSING” in the Service and Adjustments section of this manual.
- The left hand side of mower should be used for trimming.
- Drive so that clippings are discharged onto the area that has already been cut. Have the cut area to the right of the tractor. This will result in a more even distribution of clippings and more uniform cutting.
- When mowing large areas, start by turning to the right so that clippings will discharge away from shrubs, fences, driveways, etc. After one or two rounds, mow in the opposite direction making left hand turns until finished.

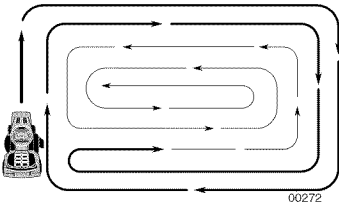

- If grass is extremely tall, it should be mowed twice to reduce load and possible fire hazard from dried clippings. Make first cut relatively high; the second to the desired height.
- Do not mow grass when it is wet. Wet grass will plug mower and leave undesirable clumps. Allow grass to dry before mowing.
- **Always operate engine at full throttle when mowing** to assure better mowing performance and proper discharge of material. Regulate ground speed by selecting a low enough gear to give the mower cutting performance as well as the quality of cut desired.
- When operating attachments, select a ground speed that will suit the terrain and give best performance of the attachment being used.

MULCHING MOWING TIPS

IMPORTANT: For best performance, keep mower housing free of built-up grass and trash. Clean after each use.

- The special mulching blade will recut the grass clippings many times and reduce them in size so that as they fall onto the lawn they will disperse into the grass and not be noticed. Also, the mulched grass will biodegrade quickly to provide nutrients for the lawn. Always mulch with your highest engine (blade) speed as this will provide the best recutting action of the blades.
- Avoid cutting your lawn when it is wet. Wet grass tends to form clumps and interferes with the mulching action. The best time to mow your lawn is the early afternoon. At this time the grass has dried, the newly cut area will not be exposed to direct sunlight.
- For best results, adjust the mower cutting height so that the mower cuts off only the top one-third of the grass blades. For extremely heavy grass, reduce your width of cut on each pass and mow slowly.

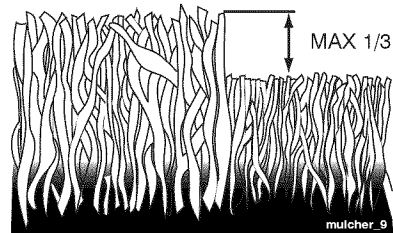

- Certain types of grass and grass conditions may require that an area be mulched a second time to completely hide the clippings. When doing a second cut, mow across (perpendicular) to the first cut path.
- Change your cutting pattern from week to week. Mow north to south one week then change to east to west the next week. This will help prevent matting and graining of the lawn.

MAINTENANCE

MAINTENANCE SCHEDULE		SERVICE DATES						
FILL IN DATES AS YOU COMPLETE REGULAR SERVICE		BEFORE EACH USE	EVERY 8 HOURS	EVERY 25 HOURS	EVERY 50 HOURS	EVERY 100 HOURS	EVERY SEASON	BEFORE STORAGE
T R A C T O R	Check Brake Operation	✓	✓					
	Check Tire Pressure	✓	✓					
	Check Operator Presence and Interlock Systems	✓						
	Check for Loose Fasteners	✓			✓ ₅	✓		
	Sharpen/Replace Mower Blades			✓ ₃				
	Lubrication Chart			✓ ₄		✓		
	Check Battery Level			✓ ₄			✓	
	Clean Battery and Terminals			✓ ₄			✓	
	Check Transaxle Cooling			✓ ₄				
	Check V-Belts				✓			
E N G I N E	Check Engine Oil Level	✓	✓					
	Change Engine Oil (with oil filter)			✓ _{1,2}		✓		
	Change Engine Oil (without oil filter)			✓ _{1,2}		✓		
	Clean Air Filter			✓ ₂				
	Clean Air Screen			✓ ₂				
	Inspect Muffler/Spark Arrester			✓				
	Replace Oil Filter (If equipped)				✓ _{1,2}			
	Clean Engine Cooling Fins				✓ ₂			
	Replace Spark Plug				✓ ₂	✓		
	Replace Air Filter Paper Cartridge				✓ ₂			
Replace Fuel Filter					✓			

- 1 - Change more often when operating under a heavy load or in high ambient temperatures.
 2 - Service more often when operating in dirty or dusty conditions.

- 3 - Replace blades more often when mowing in sandy soil.
 4 - Not required if equipped with maintenance-free battery.
 5 - Tighten front axle pivot bolt to 35 ft.-lbs. maximum.

GENERAL RECOMMENDATIONS

The warranty on this tractor does not cover items that have been subjected to operator abuse or negligence. To receive full value from the warranty, operator must maintain tractor as instructed in this manual.

Some adjustments will need to be made periodically to properly maintain your tractor.

At least once a season, check to see if you should make any of the adjustments described in the Service and Adjustments section of this manual.

- At least once a year you should replace the spark plug, clean or replace air filter, and check blades and belts for wear. A new spark plug and clean air filter assure proper air-fuel mixture and help your engine run better and last longer.

BEFORE EACH USE

- Check engine oil level.
- Check brake operation.
- Check tire pressure.
- Check operator presence and interlock systems for proper operation.
- Check for loose fasteners.

LUBRICATION CHART

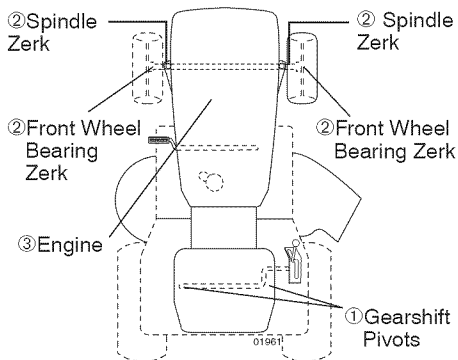

- SAE 30 or 10w30 Motor Oil
- General Purpose Grease
- Refer to Maintenance "ENGINE" Section

IMPORTANT: Do not oil or grease the pivot points which have special nylon bearings. Viscous lubricants will attract dust and dirt that will shorten the life of the self-lubricating bearings. If you feel they must be lubricated, use only a dry, powdered graphite type lubricant sparingly.

TRACTOR

Always observe safety rules when performing any maintenance.

BRAKE OPERATION

If tractor requires more than six (6) feet stopping distance at high speed in highest gear, then brake must be adjusted. (See "TO ADJUST BRAKE" in the Service and Adjustments section of this manual).

TIRES

- Maintain proper air pressure in all tires (See "PRODUCT SPECIFICATIONS" section of this manual).
- Keep tires free of gasoline, oil, or insect control chemicals which can harm rubber.
- Avoid stumps, stones, deep ruts, sharp objects and other hazards that may cause tire damage.

NOTE: To seal tire punctures and prevent flat tires due to slow leaks, tire sealant may be purchased from your local parts dealer. Tire sealant also prevents tire dry rot and corrosion.

OPERATOR PRESENCE SYSTEM

Be sure operator presence and interlock systems are working properly. If your tractor does not function as described, repair the problem immediately.

- The engine should not start unless the clutch/brake pedal is fully depressed and attachment clutch control is in the disengaged position.
- When the engine is running, any attempt by the operator to leave the seat without first setting the parking brake should shut off the engine.
- When the engine is running and the attachment clutch is engaged, any attempt by the operator to leave the seat should shut off the engine.
- The attachment clutch should never operate unless the operator is in the seat.

BLADE CARE

For best results mower blades must be kept sharp. Replace bent or damaged blades.

BLADE REMOVAL

1. Raise mower to highest position to allow access to blades.
2. Remove blade bolt, lock washer and flat washer securing blade.
3. Install new or resharpened blade with trailing edge up towards deck as shown.

IMPORTANT: To ensure proper assembly, center hole in blade must align with star on mandrel assembly.

4. Reassemble blade bolt, lock washer and flat washer in exact order as shown.
5. Tighten blade bolt securely (27-35 Ft. Lbs. torque).

IMPORTANT: Blade bolt is heat treated. If bolt needs replacing, replace only with approve bolt shown in the Repair Parts.

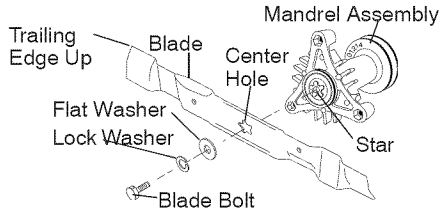

TO SHARPEN BLADE

NOTE: We do not recommend sharpening blade - but if you do, be sure the blade is balanced.

Care should be taken to keep the blade balanced. An unbalanced blade will cause excessive vibration and eventual damage to mower and engine.

- The blade can be sharpened with a file or on a grinding wheel. Do not attempt to sharpen while on the mower.
- To check blade balance, you will need a 5/8" diameter steel bolt, pin, or a cone balancer. (When using a cone balancer, follow the instructions supplied with balancer.)

NOTE: Do not use a nail for balancing blade. The lobes of the center hole may appear to be centered, but are not.

- Slide blade on to an unthreaded portion of the steel bolt or pin and hold the bolt or pin parallel with the ground. If blade is balanced, it should remain in a horizontal position. If either end of the blade moves downward, sharpen the heavy end until the blade is balanced.

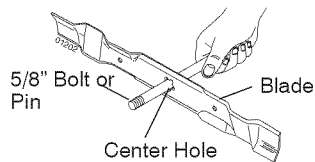

BATTERY

Your tractor has a battery charging system which is sufficient for normal use. However, periodic charging of the battery with an automotive charger will extend its life.

- Keep battery and terminals clean.
- Keep battery bolts tight.
- Keep small vent holes open.
- Recharge at 6-10 amperes for 1 hour.

NOTE: The original equipment battery on your tractor is maintenance free. Do not attempt to open or remove caps or covers. Adding or checking level of electrolyte is not necessary.

TO CLEAN BATTERY AND TERMINALS

Corrosion and dirt on the battery and terminals can cause the battery to “leak” power.

1. Remove terminal guard.
2. Disconnect BLACK battery cable first then RED battery cable and remove battery from tractor.
3. Rinse the battery with plain water and dry.
4. Clean terminals and battery cable ends with wire brush until bright.
5. Coat terminals with grease or petroleum jelly.
6. Reinstall battery (See “REPLACING BATTERY” in the SERVICE AND ADJUSTMENTS section of this manual).

TRANSAXLE COOLING

Keep transaxle free from build-up of dirt and chaff which can restrict cooling.

V-BELTS

Check V-belts for deterioration and wear after 100 hours of operation and replace if necessary. The belts are not adjustable. Replace belts if they begin to slip from wear.

ENGINE LUBRICATION

Only use high quality detergent oil rated with API service classification SG-SL. Select the oil's SAE viscosity grade according to your expected operating temperature.

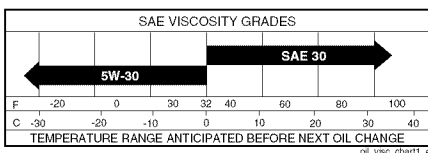

NOTE: Although multi-viscosity oils (5W30, 10W30 etc.) improve starting in cold weather, they will result in increased oil consumption when used above 32°F. Check your engine oil level more frequently to avoid possible engine damage from running low on oil.

Change the oil after every 50 hours of operation or at least once a year if the tractor is not used for 50 hours in one year.

Check the crankcase oil level before starting the engine and after each eight (8) hours of operation. Tighten oil fill cap/dipstick securely each time you check the oil level.

TO CHANGE ENGINE OIL

Determine temperature range expected before oil change. All oil must meet API service classification SG-SL.

- Be sure tractor is on level surface.
 - Oil will drain more freely when warm.
 - Catch oil in a suitable container.
1. Remove oil fill cap/dipstick. Be careful not to allow dirt to enter the engine when changing oil.
 2. Remove yellow cap from end of drain valve and install the drain tube onto the fitting.

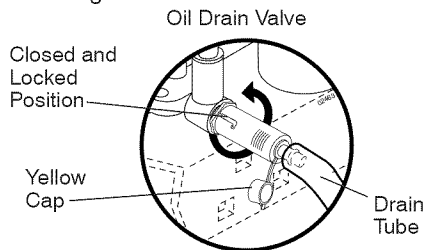

3. Unlock drain valve by pushing inward slightly and turning counterclockwise.
4. To open, pull out on the drain valve.
5. After oil has drained completely, close and lock the drain valve by pushing inward and turning clockwise until the pin is in the locked position as shown.
6. Remove the drain tube and replace the cap onto the end of the drain valve.
7. Refill engine with oil through oil fill dipstick tube. Pour slowly. Do not overfill. For approximate capacity see “PRODUCT SPECIFICATIONS” section of this manual.
8. Use gauge on oil fill cap/dipstick for checking level. For accurate reading, tighten dipstick cap securely onto the tube before removing dipstick. Keep oil at “FULL” line on dipstick. Tighten cap onto the tube securely when finished.

ENGINE OIL FILTER

Replace the engine oil filter every season or every other oil change if the tractor is used more than 100 hours in one year.

AIR FILTER

Your engine will not run properly using a dirty air filter. Replace pre-cleaner after every 25 hours of operation or every season. Service paper cartridge every 100 hours of operation or every season, whichever occurs first.

Service air cleaner more often under dusty conditions.

1. Pull up on air filter cover handle and rotate towards engine.
2. Remove cover.
3. Carefully remove air filter cartridge and pre-cleaner from base.
4. Clean base carefully to prevent debris from falling into carburetor.

NOTE: If very dirty or damaged, replace cartridge.

5. Place new pre-cleaner and cartridge firmly in base.
6. Align tabs on cover with slots in blower housing and replace cover.
7. Hook handle on cover and push down on handle to close.

IMPORTANT: Petroleum solvents, such as kerosene, are not to be used to clean the cartridge. They may cause deterioration of the cartridge. Do not oil cartridge. Do not use pressurized air to clean cartridge.

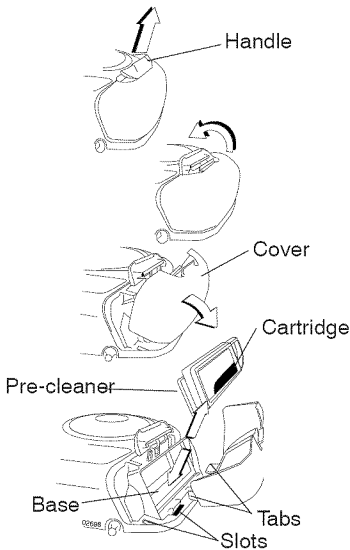

CLEAN AIR SCREEN

Air screen must be kept free of dirt and chaff to prevent engine damage from overheating. Clean with a wire brush or compressed air to remove dirt and stubborn dried gum fibers.

ENGINE COOLING SYSTEM

Debris may clog the engine's air cooling system. Remove blower housing and clean area shown to prevent overheating and engine damage.

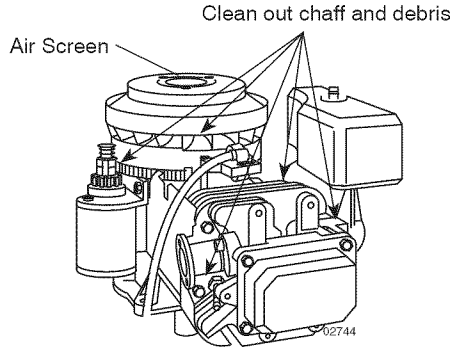

MUFFLER

Inspect and replace corroded muffler and spark arrester (if equipped) as it could create a fire hazard and/or damage.

SPARK PLUG(S)

Replace spark plug(s) at the beginning of each mowing season or after every 100 hours of operation, whichever occurs first. Spark plug type and gap setting are shown in "PRODUCT SPECIFICATIONS" section of this manual.

IN-LINE FUEL FILTER

The fuel filter should be replaced once each season. If fuel filter becomes clogged, obstructing fuel flow to carburetor, replacement is required.

1. With engine cool, remove filter and plug fuel line sections.
2. Place new fuel filter in position in fuel line with arrow pointing towards carburetor.
3. Be sure there are no fuel line leaks and clamps are properly positioned.
4. Immediately wipe up any spilled gasoline.

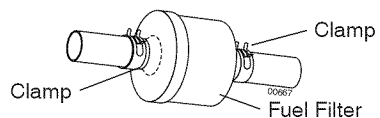

CLEANING

- Clean engine, battery, seat, finish, etc. of all foreign matter.
- Keep finished surfaces and wheels free of all gasoline, oil, etc.
- Protect painted surfaces with automotive type wax.

We do not recommend using a garden hose or pressure washer to clean your tractor unless the engine and transmission are covered to keep water out. Water in engine or transmission will shorten the useful life of your tractor. Use compressed air or a leaf blower to remove grass, leaves and trash from tractor and mower.

SERVICE AND ADJUSTMENTS



WARNING: TO AVOID SERIOUS INJURY, BEFORE PERFORMING ANY SERVICE OR ADJUSTMENTS:

1. Depress clutch/brake pedal fully and set parking brake.
2. Place gearshift lever in neutral (N) position.
3. Place attachment clutch in "DISENGAGED" position.
4. Turn ignition key to "STOP" and remove key.
5. Make sure the blades and all moving parts have completely stopped.
6. Disconnect spark plug wire from spark plug and place wire where it cannot come in contact with plug.

TRACTOR

TO REMOVE MOWER

Mower will be easier to remove from the right side of tractor.

1. Place attachment clutch switch in "DISENGAGED" position.
2. Move attachment lift lever forward to lower mower to its lowest position.
3. Roll belt off electric clutch pulley.
4. Disconnect anti-sway bar from chassis bracket by removing retainer spring.
5. Disconnect suspension arms from rear deck brackets by removing retainer springs.
6. Disconnect front links from deck by removing retainer springs.
7. Raise lift lever to raise suspension arms. Slide mower out from under tractor.

IMPORTANT: If an attachment other than the mower deck is to be mounted on the tractor, remove the front links.

TO INSTALL MOWER

1. Raise attachment lift lever to its highest position.
2. Slide mower under tractor with deflector shield to right side of tractor.
3. Lower lift lever to its lowest position.
4. Connect front links to mower deck and secure with retainer springs.
5. Connect suspension arms to rear deck brackets and secure with retainer springs.
6. Connect anti-sway bar to chassis bracket and secure with retainer spring.
7. Install belt into electric clutch pulley groove.

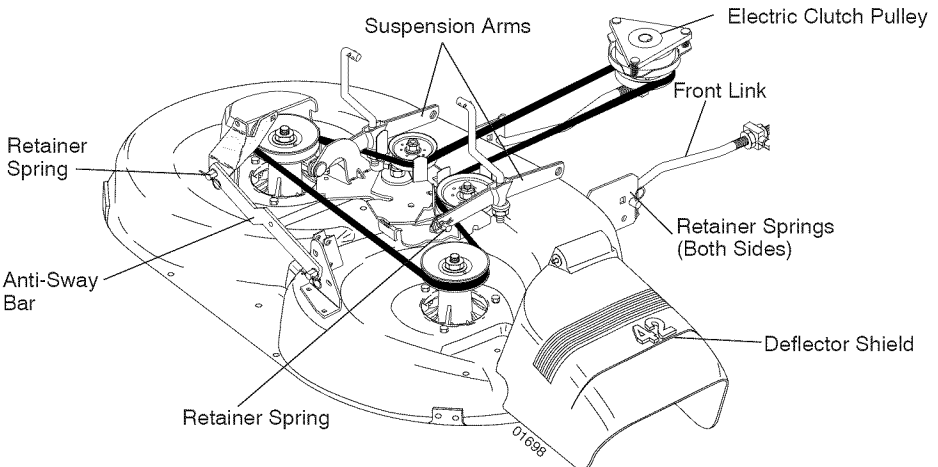

TO LEVEL MOWER HOUSING

Adjust the mower while tractor is parked on level ground or driveway. Make sure tires are properly inflated (See "PRODUCT SPECIFICATIONS" section of this manual). If tires are over or underinflated, you will not properly adjust your mower.

SIDE-TO-SIDE ADJUSTMENT WITH BUBBLE LEVEL

NOTE: If necessary, check side-to-side surface below tractor for levelness with a long board and the bubble level.

- Using the lift lever, place mower in position where no part of the mower, including gauge wheels, is touching the ground.
- From left side of tractor, find the level decal on top of mower and place bubble level on decal as indicated.
- Mower is level side-to-side when bubble is between the two lines in the bubble level.
- If adjustment is necessary, under left hand footrest, turn lift link adjustment nut (above yellow cap) in appropriate direction to bring bubble between the lines in the bubble level.
- Remove bubble level from mower and store in a safe place.

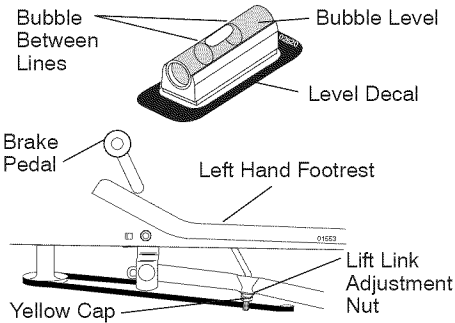

ALTERNATE SIDE-TO-SIDE ADJUSTMENT METHOD

- Raise mower to its highest position.
- At the midpoint of both sides of mower, measure height from bottom edge of mower to ground. Distance "A" on both sides of mower should be the same or within 1/4" of each other.
- If adjustment is necessary, make adjustment on one side of mower only.
- To raise one side of mower, tighten lift link adjustment nut on that side.
- To lower one side of mower, loosen lift link adjustment nut on that side.

NOTE: Each full turn of adjustment nut will change mower height about 1/8".

- Recheck measurements after adjusting.

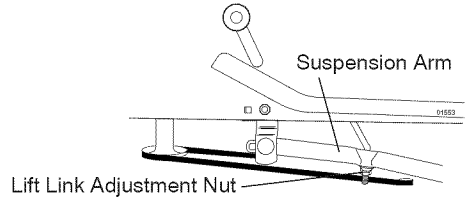
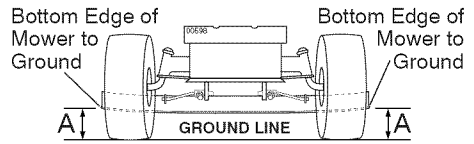

FRONT-TO-BACK ADJUSTMENT

IMPORTANT: Deck must be level side-to-side. If the following front-to-back adjustment is necessary, be sure to adjust both front links equally so mower will stay level side-to-side.

To obtain the best cutting results, the mower housing should be adjusted so that the front is approximately 1/8" to 1/2" lower than the rear when the mower is in its highest position. Check adjustment on right side of tractor. Measure distance "D" directly in front of and behind the mandrel at bottom edge of mower housing as shown.

- Before making any necessary adjustments, check that both front links are equal in length.
- If links are not equal in length, adjust one link to same length as other link.
- To lower front of mower loosen nut "E" on both front links an equal number of turns.
- When distance "D" is 1/8" to 1/2" lower at front than rear, tighten nuts "F" against trunnion on both front links.
- To raise front of mower, loosen nut "F" from trunnion on both front links. Tighten nut "E" on both front links an equal number of turns. The two front links must remain equal in length.
- When distance "D" is 1/8" to 1/2" lower at front than rear, tighten nut "F" against trunnion on both front links.
- Recheck side-to-side adjustment. Measure distance "D" directly in front of and behind the mandrel at bottom edge of mower housing as shown.
- Before making any necessary adjustments, check that both front links are equal in length.
- If links are not equal in length, adjust one link to same length as other link.
- To lower front of mower loosen nut "E" on both front links an equal number of turns.
- When distance "D" is 1/8" to 1/2" lower at front than rear, tighten nuts "F" against trunnion on both front links.

- To raise front of mower, loosen nut "F" from trunnion on both front links. Tighten nut "E" on both front links an equal number of turns. The two front links must remain equal in length.
- When distance "D" is 1/8" to 1/2" lower at front than rear, tighten nut "F" against trunnion on both front links.
- Recheck side-to-side adjustment.

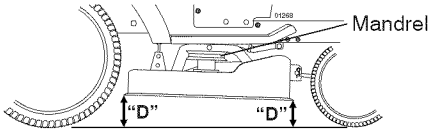

BOTH FRONT LINKS MUST BE EQUAL IN LENGTH

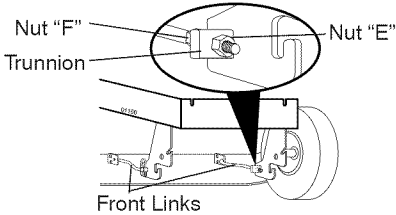
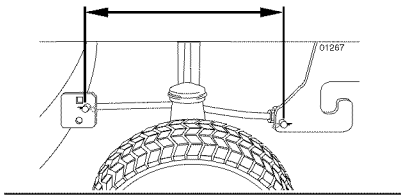

TO REPLACE MOWER BLADE DRIVE BELT

The mower blade drive belt may be replaced without tools. Park the tractor on level surface. Engage parking brake.

BELT REMOVAL -

1. Remove mower from tractor (See "TO REMOVE MOWER" in this section of manual).
2. Work belt off both mandrel pulleys and idler pulleys.
3. Pull belt away from mower.

BELT INSTALLATION -

1. Work belt around both mandrel pulleys and idler pulleys
2. Make sure belt is in all pulley grooves and inside all belt guides.
3. Install mower (See "To Install Mower" in this section of this manual).

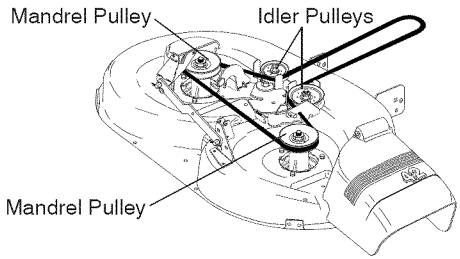

TO CHECK AND ADJUST BRAKE

Your tractor is equipped with an adjustable brake system which is mounted on the right side of the transaxle.

If tractor requires more than five (5) feet to stop at highest speed in highest gear on a level, dry concrete or paved surface, then brake must be checked and adjusted.

TO CHECK BRAKE

1. Park tractor on a level, dry concrete or paved surface, depress clutch/brake pedal all the way down and engage parking brake.
2. Place gear shift lever in neutral (N) position.

The rear wheels must lock and skid when you try to manually push the tractor forward. If the rear wheels rotate, the brake needs to be adjusted or the pads need to be replaced.

TO ADJUST BRAKE

1. Depress clutch/brake pedal all the way down and engage parking brake.
2. Measure distance between brake operating arm and nut "A" on brake rod.
3. If distance is other than 1-1/2", loosen jam nut and turn nut "A" until distance becomes 1-1/2". Retighten jam nut against nut "A".
4. Road test tractor for proper stopping distance as stated above. Readjust if necessary. If stopping distance is still greater than five (5) feet in highest gear, further maintenance is necessary. Replace brake pads or contact a Sears or other qualified service center.

With Parking Brake "Engaged"

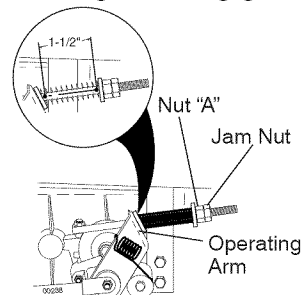

TO REPLACE MOTION DRIVE BELT

Park the tractor on level surface. Engage parking brake. For assistance, there is a belt installation guide decal on bottom side of left footrest.

BELT REMOVAL -

1. Remove mower (See "TO REMOVE MOWER" in this section of manual).
- NOTE:** Observe entire motion drive belt and position of all belt guides and keepers.
2. Disconnect clutch wire harness.
 3. Remove clutch locator.
 4. Remove belt from stationary idler and clutching idler.
 5. Remove belt downward from engine pulley and around electric clutch.
 6. Pull belt slack toward rear of tractor. Remove belt upwards from transaxle pulley by deflecting belt keepers.
 7. Remove belt from center span keeper and pull belt away from tractor.

BELT INSTALLATION -

1. Carefully work new belt down between transaxle belt keepers and onto the input pulley.
2. Slide belt into the center span keeper.
3. Pull belt toward front of tractor and roll belt around electric clutch and onto engine pulley.
4. Install belt through stationary idler and clutching idler.
5. Reinstall clutch locator and tighten nut securely.
6. Reconnect clutch harness.
7. Make sure belt is in all pulley grooves and inside all belt guides and keepers.
8. Install mower (See "TO INSTALL MOWER" in this section of manual).

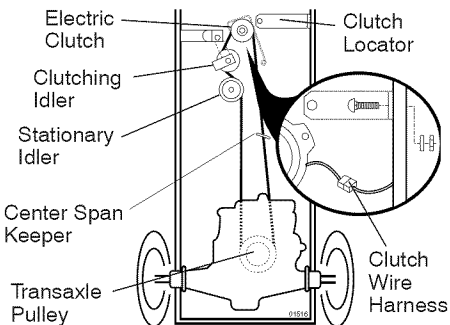

TRANSAXLE GEAR SHIFT LEVER NEUTRAL ADJUSTMENT

The transaxle should be in neutral when the gear shift lever is in neutral (N) (lock gate) position. The adjustment is preset at the factory; however, if adjustment is needed, proceed as follows:

1. Make sure transaxle is in neutral (N).

NOTE: When the tractor rear wheels move freely, the transaxle is in neutral.

2. Loosen adjustment bolt in front of the right rear wheel.
3. Position the gear shift lever in the neutral (N) position.
4. Tighten adjustment bolt securely.

NOTE: If additional clearance is needed to get to adjustment bolt, move mower deck height to the lowest position.

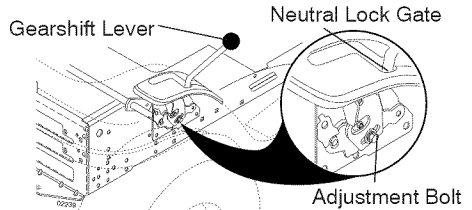

TO ADJUST STEERING WHEEL ALIGNMENT

If steering wheel crossbars are not horizontal (left to right) when wheels are positioned straight forward, remove steering wheel and reassemble with crossbars horizontal. Tighten securely.

FRONT WHEEL TOE-IN/CAMBER

The front wheel toe-in and camber are not adjustable on your tractor. If damage has occurred to affect the front wheel toe-in or camber, contact a Sears or other qualified service center.

TO REMOVE WHEEL FOR REPAIRS

1. Block up axle securely.
 2. Remove axle cover, retaining ring and washers to allow wheel removal (rear wheels have a square key - Do not lose).
 3. Repair tire and reassemble.
- NOTE:** On rear wheels only: align grooves in rear wheel hub and axle. Insert square key.
4. Replace washers and snap retaining ring securely in axle groove.
 5. Replace axle cover.

NOTE: To seal tire punctures and prevent flat tires due to slow leaks, purchase and use tire sealant from Sears. Tire sealant also prevents tire dry rot and corrosion.

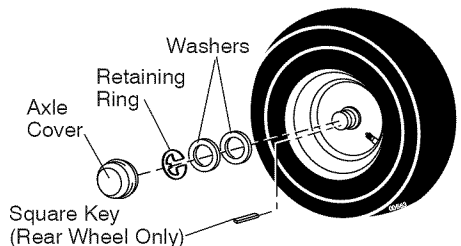

TO START ENGINE WITH A WEAK BATTERY

⚠️WARNING: Lead-acid batteries generate explosive gases. Keep sparks, flame and smoking materials away from batteries. Always wear eye protection when around batteries.

If your battery is too weak to start the engine, it should be recharged. (See "BATTERY" in the MAINTENANCE section of this manual).

If "jumper cables" are used for emergency starting, follow this procedure:

IMPORTANT: Your tractor is equipped with a 12 volt system. The other vehicle must also be a 12 volt system. Do not use your tractor battery to start other vehicles.

TO ATTACH JUMPER CABLES -

1. Connect one end of the RED cable to the POSITIVE (+) terminal of each battery(A-B), taking care not to short against tractor chassis.
2. Connect one end of the BLACK cable to the NEGATIVE (-) terminal (C) of fully charged battery.
3. Connect the other end of the BLACK cable (D) to good chassis ground, away from fuel tank and battery.

TO REMOVE CABLES, REVERSE ORDER -

1. BLACK cable first from chassis and then from the fully charged battery.
2. RED cable last from both batteries.

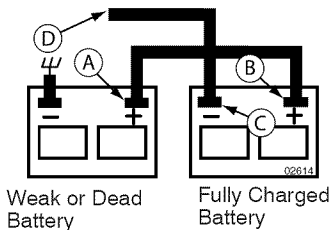

REPLACING BATTERY

⚠️WARNING: Do not short battery terminals by allowing a wrench or any other object to contact both terminals at the same time. Before connecting battery, remove metal bracelets, wristwatch bands, rings, etc. Positive terminal must be connected first to prevent sparking from accidental grounding.

1. Lift hood to raised position.
2. Remove terminal guard.
3. Disconnect BLACK battery cable then RED battery cable and carefully remove battery from tractor.
4. Install new battery with terminals in same position as old battery.
5. Reinstall terminal guard.

6. First connect RED battery cable to positive (+) battery terminal with hex bolt and keps nut as shown. Tighten securely.
7. Connect BLACK grounding cable to negative (-) battery terminal with remaining hex bolt and keps nut. Tighten securely
8. Close terminal access doors.
9. Close hood.

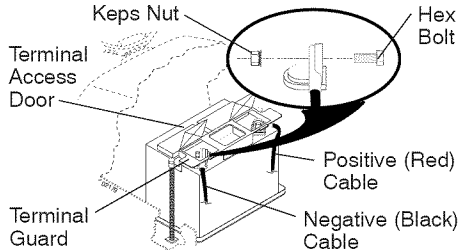

TO REPLACE HEADLIGHT BULB

1. Raise hood.
2. Pull bulb holder out of the hole in the backside of the grill.
3. Replace bulb in holder and push bulb holder securely back into the hole in the backside of the grill.
4. Close hood.

INTERLOCKS AND RELAYS

Loose or damaged wiring may cause your tractor to run poorly, stop running, or prevent it from starting.

- Check wiring. See electrical wiring diagram in the Repair Parts section.

TO REPLACE FUSE

Replace with 20 amp automotive-type plug-in fuse. The fuse holder is located behind the dash.

TO REMOVE HOOD AND GRILL ASSEMBLY

1. Raise hood.
2. Unsnap headlight wire connector.
3. Stand in front of tractor. Grasp hood at sides, tilt toward engine and lift off of tractor.
4. When replacing hood, be sure to re-connect the headlight wire connector.

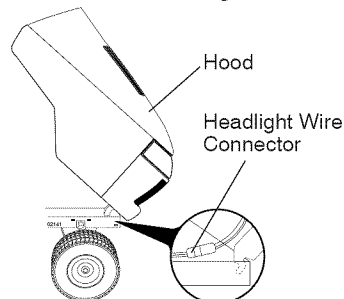

ENGINE

Maintenance, repair, or replacement of the emission control devices and systems, which are being done at the customers expense, may be performed by any non-road engine repair establishment or individual. Warranty repairs must be performed by an authorized engine manufacturer's service outlet.

TO ADJUST THROTTLE CONTROL CABLE

The throttle control has been preset at the factory and adjustment should not be necessary. Check adjustment as described below before loosening cable. If adjustment is necessary, proceed as follows:

1. With engine not running, move throttle control lever from slow to choke position. Slowly move lever from choke to fast position.
2. Check that holes "A" in governor control lever and hole in governor plate line-up. If holes "A" are not aligned, loosen clamp screw and move throttle cable until holes are aligned. Tighten clamp screw securely.

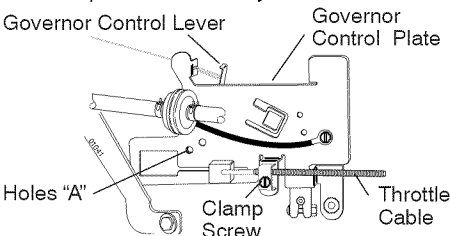

TO ADJUST CARBURETOR

NOTE: The carburetor on this engine is low emission. It is equipped with an idle fuel adjusting needle with a limiter cap, which allows some adjustment within the limits allowed by the cap. Do not attempt to remove the limiter cap. The limiter cap cannot be removed without breaking the adjusting needle.

The carburetor has been preset at the factory and adjustment should not be necessary. However, minor adjustment may be required to compensate for differences in fuel, temperature, altitude or load. If the carburetor does need adjustment, proceed as follows:

In general, turning idle mixture valve **in** (clockwise) decreases the supply of fuel to the engine giving a leaner fuel/air mixture. Turning the idle mixture valve **out** (counterclockwise) increases the supply of fuel to the engine giving a richer fuel/air mixture.

IMPORTANT: Damage to the needle valve and the seat in carburetor may result if screw is turned in too tight.

PRELIMINARY SETTING -

1. Air cleaner assembly must be assembled to the carburetor when making carburetor adjustments.
2. Be sure the throttle control cable is adjusted properly (see above).

FINAL SETTING -

1. Start engine and allow to warm for five minutes. Make final adjustments with engine running and shift/motion control lever in neutral (**N**) position.
2. Move throttle control lever to slow position. With finger, rotate and hold throttle lever against idle speed screw. Turn idle speed screw to attain 1750 RPM.
3. While still holding throttle lever against idle speed screw, turn idle mixture valve full travel clockwise then counterclockwise until engine runs rough. Turn valve to a point midway between those two positions. Release throttle lever.

ACCELERATION TEST -

4. Move throttle control lever from slow to fast position. If engine hesitates or dies, turn idle mixture valve **out** (counterclockwise) 1/8 turn. Repeat test and continue to adjust, if necessary, until engine accelerates smoothly.

High speed stop is factory adjusted. Do not adjust - damage may result.

IMPORTANT: Never tamper with the engine governor, which is factory set for proper engine speed. Overspeeding the engine above the factory high speed setting can be dangerous. If you think the engine-governed high speed needs adjusting, contact a Sears or other qualified service center, which has proper equipment and experience to make any necessary adjustments.

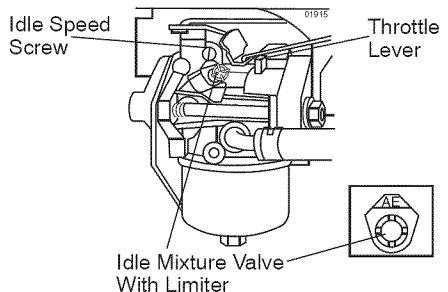

STORAGE

Immediately prepare your tractor for storage at the end of the season or if the tractor will not be used for 30 days or more.

CAUTION: Never store the tractor with gasoline in the tank inside a building where fumes may reach an open flame or spark. Allow the engine to cool before storing in any enclosure.

TRACTOR

Remove mower from tractor for winter storage. When mower is to be stored for a period of time, clean it thoroughly, remove all dirt, grease, leaves, etc. Store in a clean, dry area.

1. Clean entire tractor (See "CLEANING" in the Maintenance section of this manual).
2. Inspect and replace belts, if necessary (See belt replacement instructions in the Service and Adjustments section of this manual).
3. Lubricate as shown in the Maintenance section of this manual.
4. Be sure that all nuts, bolts and screws are securely fastened. Inspect moving parts for damage, breakage and wear. Replace if necessary.
5. Touch up all rusted or chipped paint surfaces; sand lightly before painting.

BATTERY

- Fully charge the battery for storage.
- After a period of time in storage, battery may require recharging.
- To help prevent corrosion and power leakage during long periods of storage, battery cables should be disconnected and battery cleaned thoroughly (see "TO CLEAN BATTERY AND TERMINALS" in the Maintenance section of this manual).
- After cleaning, leave cables disconnected and place cables where they cannot come in contact with battery terminals.
- If battery is removed from tractor for storage, do not store battery directly on concrete or damp surfaces.

ENGINE

FUEL SYSTEM

IMPORTANT: It is important to prevent gum deposits from forming in essential fuel system parts such as carburetor, fuel hose, or tank during storage. Also, alcohol

blended fuels (called gasohol or using ethanol or methanol) can attract moisture which leads to separation and formation of acids during storage. Acidic gas can damage the fuel system of an engine while in storage.

- Empty the fuel tank by starting the engine and letting it run until the fuel lines and carburetor are empty.
- Never use engine or carburetor cleaner products in the fuel tank or permanent damage may occur.
- Use fresh fuel next season.

NOTE: Fuel stabilizer is an acceptable alternative in minimizing the formation of fuel gum deposits during storage. Add stabilizer to gasoline in fuel tank or storage container. Always follow the mix ratio found on stabilizer container. Run engine at least 10 minutes after adding stabilizer to allow the stabilizer to reach the carburetor. Do not empty the gas tank and carburetor if using fuel stabilizer.

ENGINE OIL

Drain oil (with engine warm) and replace with clean engine oil. (See "ENGINE" in the Maintenance section of this manual).

CYLINDER(S)

1. Remove spark plug(s).
2. Pour one ounce of oil through spark plug hole(s) into cylinder(s).
3. Turn ignition key to "START" position for a few seconds to distribute oil.
4. Replace with new spark plug(s).

OTHER

- Do not store gasoline from one season to another.
- Replace your gasoline can if your can starts to rust. Rust and/or dirt in your gasoline will cause problems.
- If possible, store your tractor indoors and cover it to give protection from dust and dirt.
- Cover your tractor with a suitable protective cover that does not retain moisture. Do not use plastic. Plastic cannot breathe which allows condensation to form and will cause your tractor to rust.

IMPORTANT: Never cover tractor while engine and exhaust areas are still warm.

TROUBLESHOOTING CHART:

See appropriate section in manual unless directed to Sears service center

PROBLEM	CAUSE	CORRECTION
Will not start	<ol style="list-style-type: none">1. Out of fuel.2. Engine not "CHOKED" properly.3. Engine flooded. 4. Bad spark plug.5. Dirty air filter.6. Dirty fuel filter.7. Water in fuel. 8. Loose or damaged wiring.9. Carburetor out of adjustment. 10. Engine valves out of adjustment.	<ol style="list-style-type: none">1. Fill fuel tank.2. See "TO START ENGINE" in Operation section.3. Wait several minutes before attempting to start.4. Replace spark plug.5. Clean/replace air filter.6. Replace fuel filter.7. Empty fuel tank and carburetor, refill tank with fresh gasoline and replace fuel filter.8. Check all wiring.9. See "To Adjust Carburetor" in Service and Adjustments section.10. Contact a Sears or other qualified service center.
Hard to start	<ol style="list-style-type: none">1. Dirty air filter.2. Bad spark plug.3. Weak or dead battery.4. Dirty fuel filter.5. Stale or dirty fuel. 6. Loose or damaged wiring.7. Carburetor out of adjustment. 8. Engine valves out of adjustment.	<ol style="list-style-type: none">1. Clean/replace air filter.2. Replace spark plug.3. Recharge or replace battery.4. Replace fuel filter.5. Empty fuel tank and refill tank with fresh, clean gasoline.6. Check all wiring.7. See "To Adjust Carburetor" in Service and Adjustments section.8. Contact a Sears or other qualified service center.
Engine will not turn over	<ol style="list-style-type: none">1. Clutch/brake pedal not depressed.2. Attachment clutch is engaged.3. Weak or dead battery.4. Blown fuse.5. Corroded battery terminals.6. Loose or damaged wiring.7. Faulty ignition switch.8. Faulty solenoid or starter. 9. Faulty operator presence switch(es).	<ol style="list-style-type: none">1. Depress clutch/brake pedal.2. Disengage attachment clutch.3. Recharge or replace battery.4. Replace fuse.5. Clean battery terminals.6. Check all wiring.7. Check/replace ignition switch.8. Check/replace solenoid or starter.9. Contact a Sears or other qualified service center.
Engine clicks but will not start	<ol style="list-style-type: none">1. Weak or dead battery.2. Corroded battery terminals.3. Loose or damaged wiring.4. Faulty solenoid or starter.	<ol style="list-style-type: none">1. Recharge or replace battery.2. Clean battery terminals.3. Check all wiring.4. Check/replace solenoid or starter.

TROUBLESHOOTING CHART:

See appropriate section in manual unless directed to Sears service center

PROBLEM	CAUSE	CORRECTION
Loss of power	<ol style="list-style-type: none"> Cutting too much grass/too fast. Throttle in "CHOKE" position. Build-up of grass, leaves and trash under mower. Dirty air filter. Low oil level/dirty oil. Faulty spark plug. Dirty fuel filter. Stale or dirty fuel. Water in fuel. Spark plug wire loose. Dirty engine air screen/fins. Dirty/clogged muffler. Loose or damaged wiring. Carburetor out of adjustment. Engine valves out of adjustment. 	<ol style="list-style-type: none"> Raise cutting height/reduce speed. Adjust throttle control. Clean underside of mower housing. Clean/replace air filter. Check oil level/change oil. Clean and regap or change spark plug. Replace fuel filter. Empty fuel tank and refill tank with fresh, clean gasoline. Empty fuel tank and carburetor, refill tank with fresh gasoline and replace fuel filter. Connect and tighten spark plug wire. Clean engine air screen/fins. Clean/replace muffler. Check all wiring. See "To Adjust Carburetor" in Service and Adjustments section. Contact a Sears or other qualified service center.
Excessive vibration	<ol style="list-style-type: none"> Worn, bent or loose blade. Bent blade mandrel. Loose/damaged part(s). 	<ol style="list-style-type: none"> Replace blade. Tighten blade bolt. Contact a Sears or other qualified service center. Tighten loose part(s). Replace damaged parts.
Engine continues to run when operator leaves seat with attachment clutch engaged	<ol style="list-style-type: none"> Faulty operator-safety presence control system. 	<ol style="list-style-type: none"> Check wiring, switches and connections. If not corrected, contact Sears or other qualified service center.
Poor cut - uneven	<ol style="list-style-type: none"> Worn, bent or loose blade. Mower deck not level. Buildup of grass, leaves, and trash under mower. Bent blade mandrel. Clogged mower deck vent holes from buildup of grass, leaves, and trash around mandrels. 	<ol style="list-style-type: none"> Replace blade. Tighten blade bolt. Level mower deck. Clean underside of mower housing. Contact a Sears or other qualified service center. Clean around mandrels to open vent holes.

TROUBLESHOOTING CHART:

See appropriate section in manual unless directed to Sears service center

PROBLEM	CAUSE	CORRECTION
Mower blades will not rotate	<ol style="list-style-type: none">1. Obstruction in clutch mechanism.2. Worn/damaged mower drive belt.3. Frozen idler pulley.4. Frozen blade mandrel.	<ol style="list-style-type: none">1. Remove obstruction.2. Replace mower drive belt.3. Replace idler pulley.4. Contact a Sears or other qualified service center.
Poor grass discharge	<ol style="list-style-type: none">1. Engine speed too slow.2. Travel speed too fast.3. Wet grass.4. Mower deck not level.5. Low/uneven tire air pressure.6. Worn, bent or loose blade.7. Buildup of grass, leaves and trash under mower.8. Mower drive belt worn.9. Blades improperly installed.10. Improper blades used.11. Clogged mower deck vent holes from buildup of grass, leaves, and trash around mandrels.	<ol style="list-style-type: none">1. Place throttle control in "FAST" position.2. Shift to slower speed.3. Allow grass to dry before mowing.4. Level mower deck.5. Check tires for proper air pressure.6. Replace/sharpen blade. Tighten blade bolt.7. Clean underside of mower housing.8. Replace mower drive belt.9. Reinstall blades sharp edge down.10. Replace with blades listed in this manual.11. Clean around mandrels to open vent holes.
Headlight(s) not working (if so equipped)	<ol style="list-style-type: none">1. Switch is "OFF".2. Bulb(s) or lamp(s) burned out.3. Faulty light switch.4. Loose or damaged wiring.5. Blown fuse.	<ol style="list-style-type: none">1. Turn switch "ON".2. Replace bulb(s) or lamp(s).3. Check/replace light switch.4. Check wiring and connections.5. Replace fuse.
Battery will not charge	<ol style="list-style-type: none">1. Bad battery cell(s).2. Poor cable connections.3. Faulty regulator (if so equipped).4. Faulty alternator.	<ol style="list-style-type: none">1. Replace battery.2. Check/clean all connections.3. Replace regulator.4. Replace alternator.
Engine "backfires" when turning engine "OFF"	<ol style="list-style-type: none">1. Engine throttle control not set at "SLOW" position for 30 seconds before stopping engine.	<ol style="list-style-type: none">1. Move throttle control to "SLOW" position and allow to idle for 30 seconds before stopping engine.

TRACTOR - - MODEL NUMBER 917.273631

SCHEMATIC

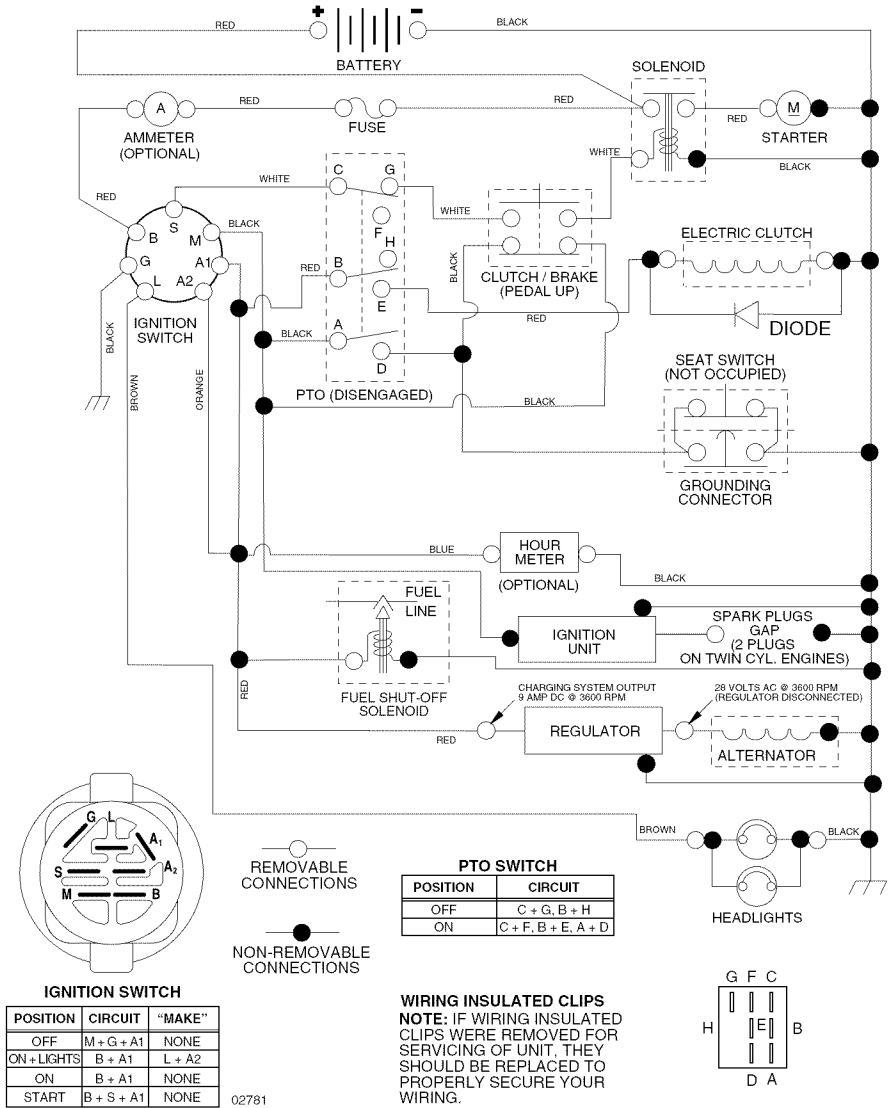

REPAIR PARTS

TRACTOR - - MODEL NUMBER 917.273631

ELECTRICAL

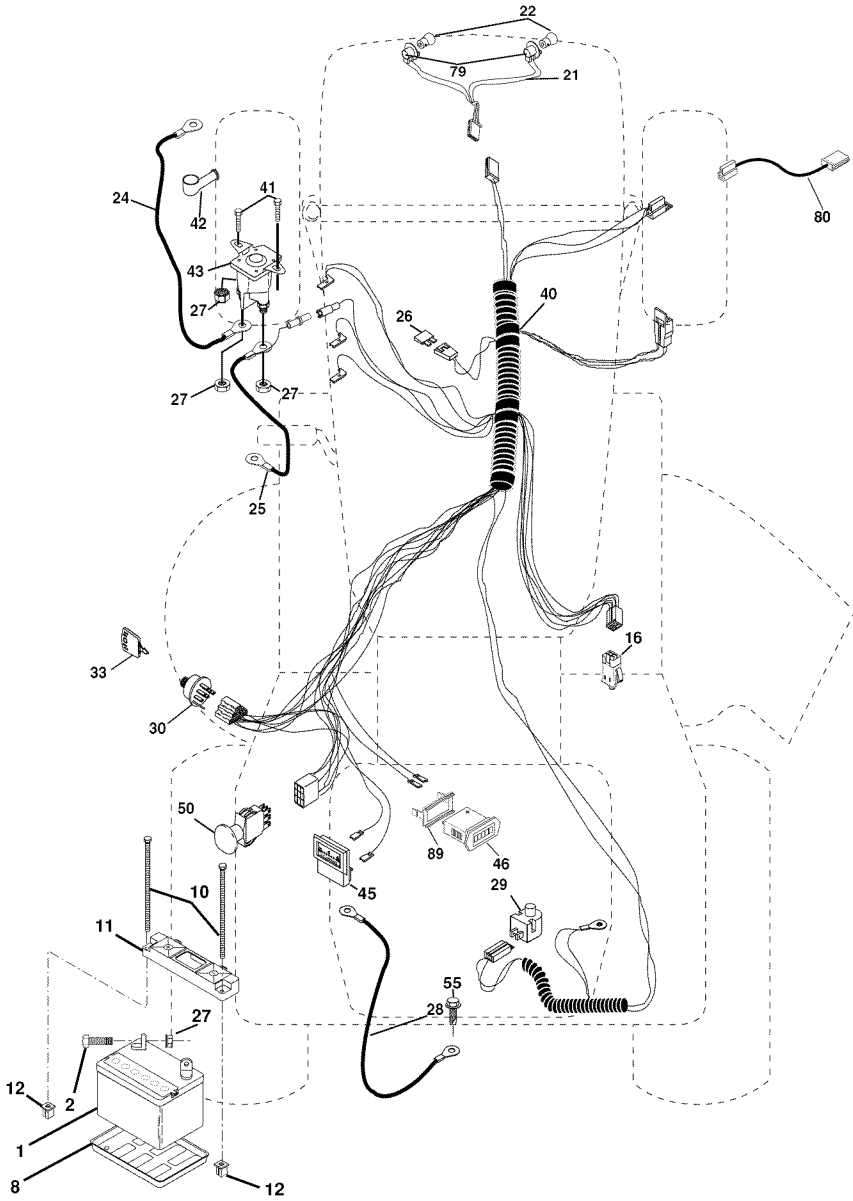

KEY NO.	PART NO.	DESCRIPTION
1	163465	Battery
2	74760412	Bolt, Hex 1/4-20 x 3/4
8	7603J	Tray, Battery
10	145211	Bolt, Battery, Front 1/4-20 x 7-1/2
11	150109	Holddown, Battery, Front
12	145769	Nut, Push, Nylon, Battery, Front 1/4
16	176138	Switch, Interlock
21	175688	Harness, Light
22	4152J	Bulb Light #1156
24	8860R	Cable Starter
25	146148	Cable
26	175158	Fuse
27	73510400	Nut, Hex, Keps 1/4-20 unc
28	145491	Cable, Ground
29	121305X	Switch, Seat
30	175566	Switch, Ignition
33	140403	Key
40	188031	Harness, Ignition
41	17720408	Screw Thd Cut 1/4-20 x 1/2
42	131563	Cover Terminal
43	178861	Soloid w/brass plunger
45	122822X	Ammeter
46	169635	Hourmeter
50	174652	Switch, PTO
55	17490508	Screw, Thd. Roll. 5/16-18 x 1/2
79	175242	Socket Asm Bulb Twistlock
80	146685	Harness Clutch EXV
89	169639	Bracket Snap-In Hourmeter

NOTE: All component dimensions given in U. S. inches 1 inch = 25.4 mm

TRACTOR - - MODEL NUMBER 917.273631
CHASSIS AND ENCLOSURES

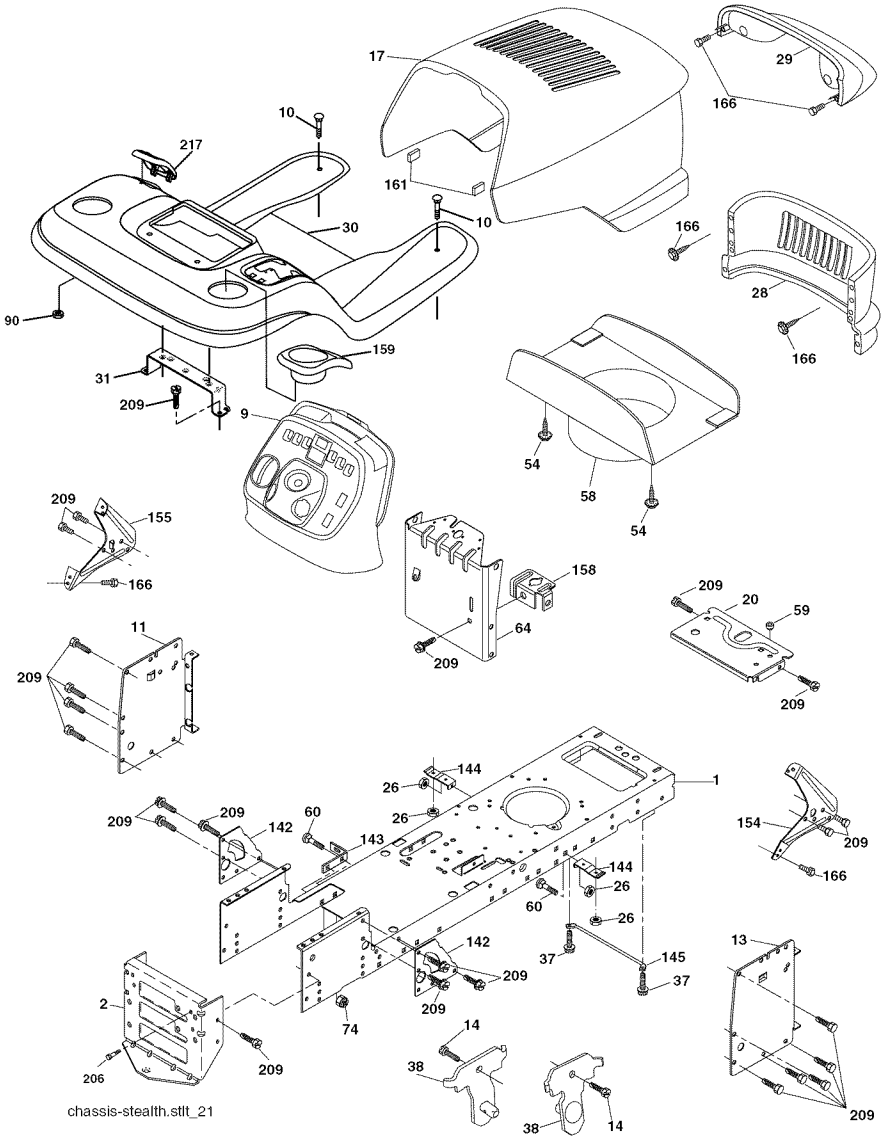

chassis-stealth.stlt_21

TRACTOR - - MODEL NUMBER 917.273631
CHASSIS AND ENCLOSURES

KEY NO.	PART NO.	DESCRIPTION
1	174619	Chassis
2	176554	Drawbar
9	161566X428	Dash
10	72140608	Bolt RDHD SQNK 3/8-16 x 1
11	167203	Panel, Dash, LH
13	188702X010	Panel, Dash, RH
14	17490608	Screw Thdrol 3/8-16 x 1/2
17	175260X615	Hood Assembly
20	162026	Plate Battery
26	STD541437	Locknut, Hex, with Insert 3/8-16 unc
28	174515X615	Grille
29	161840	Lens Bar
30	179131X615	Fender/Footrest
31	139976	Bracket, Fender/Support
37	17490508	Screw, Thdrol. 5/16-18 x 1/2 TYT
38	175710	Bracket Asm Pivot Mower Rear
54	161464	Screw 8-18 x 7/8
58	175351	Duct Hood
59	187495	Bushing
60	STD533707	Bolt Rdhd Sqnk 3/8-16 unc x 3/4
64	174997	Dash Lower
74	STD541437	Nut Crownlock 3/8-16 unc
90	124346X	Nut Self Thrd Wshd 1/4 Zinc
142	175702	Plate Reinforcement
143	186689	Bracket Swaybar Chassis
144	175582	Bracket Footrest
145	156524	Rod Pivot Chassis/Hood
154	161897	Bracket Dash Rh
155	161900	Bracket Dash Lh
158	162037	Parking Brake Bkrt
159	179950X428	Cupholder
161	164655	Bumper
166	171875	Screw HWHDH:-Lo. #13-16 x 3/4
206	170165	Bolt Shoulder 5/16-18
209	17000612	Screw Hexwsh Thdr 3/8-16 x 3/4
211	145212	Nut Hexflange Lock
217	179132X428	Console Fuel Window

NOTE: All component dimensions given in U.S. inches
1 inch = 25.4 mm

TRACTOR - - MODEL NUMBER 917.273631

GROUND DRIVE

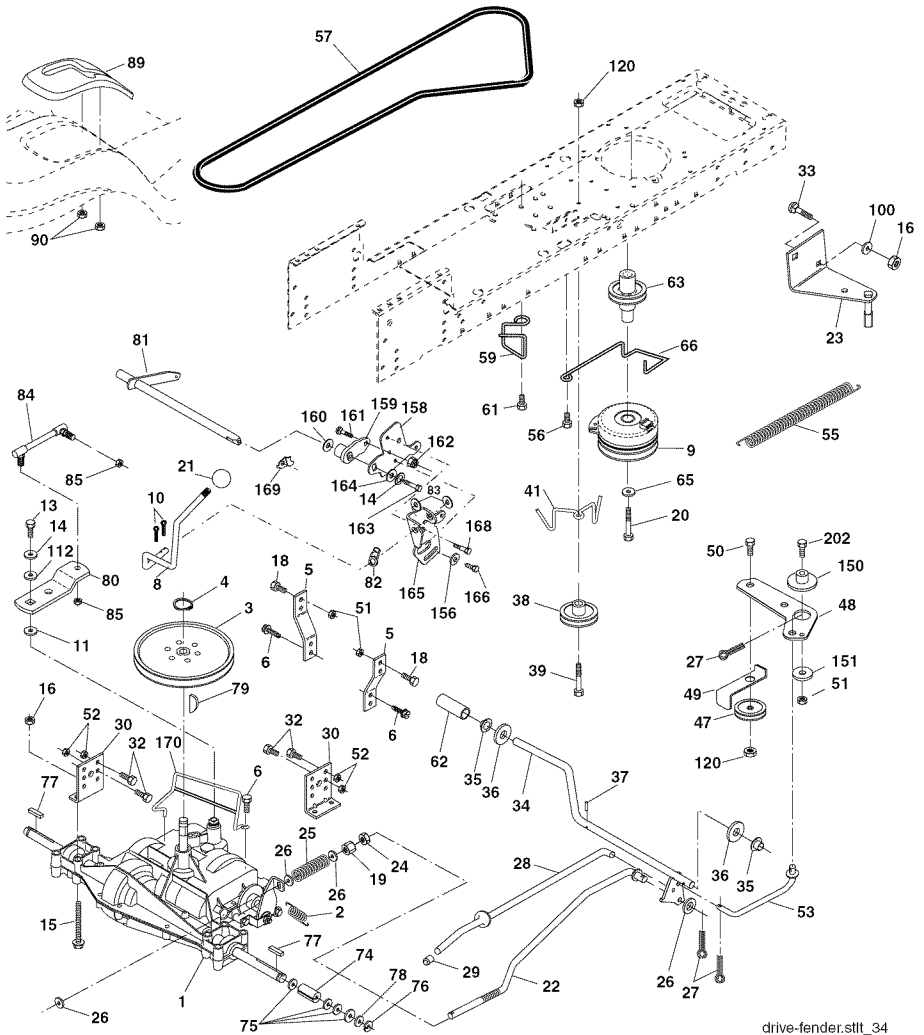

drive-fender.stlt_34

TRACTOR - - MODEL NUMBER 917.273631

GROUND DRIVE

KEY PART			KEY PART		
NO.	NO.	DESCRIPTION	NO.	NO.	DESCRIPTION
1	- - - - -	Transaxle Dana D4360-180 (See Breakdown)	56	17060620	Screw 3/8-16 x 1-1/4
2	146682	Spring, Return, Brake	57	160855	V-Belt, Ground Drive
3	123666X	Pulley, Transaxle	59	169691	Keeper, Belt, Center Span
4	12000028	Ring, Retainer	61	17120614	Screw 3/8-16 x .875
5	121520X	Strap, Torque	62	123533X	Cover, Pedal
6	17000512	Screw 5/16-18 x 3/4	63	175414	Pulley, Engine
8	165866	Rod Shifter Fender STLT	65	STD551143	Washer
9	160889	Clutch	66	154778	Keeper, Belt, Engine, Fool Proof
10	STD561210	Pin, Cotter	74	109502X	Spacer, Axle
11	105701X	Washer, Shift Plate	75	121749X	Washer 25/32 x 1-1/4 x 16 Ga.
13	74550412	Bolt 1/4-28 UNF W/Patch Gr. 8	76	STD581075	E-Ring
14	10040400	Washer Lock Hvy Helical	77	123583X	Key, Square 2.0 x .1845/1865
15	74490544	Bolt Hex FLGHD 5/16-18 Gr. 5	78	121748X	Washer 25/32 x 1-5/8 x 16 Ga.
16	STD541431	Nut Lock Hx W/Ins 5/16-18 unc	79	STD580025	Key Woodruff
18	STD523710	Bolt Fin Hex 3/8-16 unc x 1 Gr. 5	80	160783	Arm, Shift
19	STD541437	Nut	81	165593	Shaft Asm Cross
20	150280	Bolt 7/16-20 x 4 -1/4	82	165711	Spring, Torsion
21	106933X	Knob	83	19171216	Washer 17/32 x 3/4 x 16 Ga.
22	130804	Rod, Brake	84	169149	Link Transaxle
23	171258	Bracket Anti-Rotation	85	150360	Nut, Nylock
24	STD541237	Nut	89	158391X428	Console, Shift, STLT
25	106888X	Spring, Brake Rod	90	124346X	Nut, Self-Thding, Wsh Hd 1/4
26	STD551037	Washer	100	19111016	Washer 11/32 x 5/8 x 16 Ga.
27	STD561210	Pin	112	19091210	Washer 9/32 x 3/4 x 10 Ga.
28	175765	Rod, Parking Brake	120	73900600	Nut Lock Flg. 3/8-16 unc
29	124236X	Cap, Parking Brake	150	175456	Spacer Retainer
30	169592	Bracket, Transaxle	151	19133210	Washer 13/32 x 2 x 10 Ga.
32	STD523107	Bolt	156	166002	Washer Srted 5/16 ID x 1.125
33	72140506	Bolt 5/16-18 unc x 3/4	158	165589	Bracket Shift Mount
34	175578	Shaft Assembly, Foot Pedal	159	183900	Hub Shift
35	120183X	Bearing, Nylon	160	19292016	Washer
36	STD551062	Washer	161	72140406	Bolt Rdhd Sqnk 1/4-20 x 3/4 Gr.5
37	STD571810	Roll Pin	162	73680400	Nut Crownlock 1/4-20 unc
38	179114	Pulley, Composite, Flat	163	74780416	Bolt Hex Fin 1/4-20Unc x 1 Gr. 5
39	72110622	Bolt Rdhd 3/8-16 unc x 2-3/4	164	19091010	Washer
41	175556	Keeper, Belt, Idler	165	165623	Bracket Pivot Lever
47	127783	Pulley, Idler, V-Groove, Plastic	166	17490510	Screw 5/16-18 x 5/8 TT Yellow
48	154407	Bellcrank Clutch Grnd Drv Stl	168	165492	Bolt Shoulder 5/16-18 x .561
49	123205X	Retainer, Belt	169	165580	Plate Fastening Lt
50	72110612	Bolt	170	178394	Keeper Belt Transaxle
51	STD541437	Nut Crown Lock 3/8-16 unc	202	72110614	Bolt Carr. SH 3/8-16 x 1-3/4 Gr. 5
52	STD541431	Nut Crown Lock 5/16-18 unc			
53	105710X	Link, Clutch			
55	105709X	Spring, Clutch Return			

NOTE: All component dimensions given in U.S. inches
1 inch = 25.4 mm

TRACTOR - - MODEL NUMBER 917.273631

STEERING

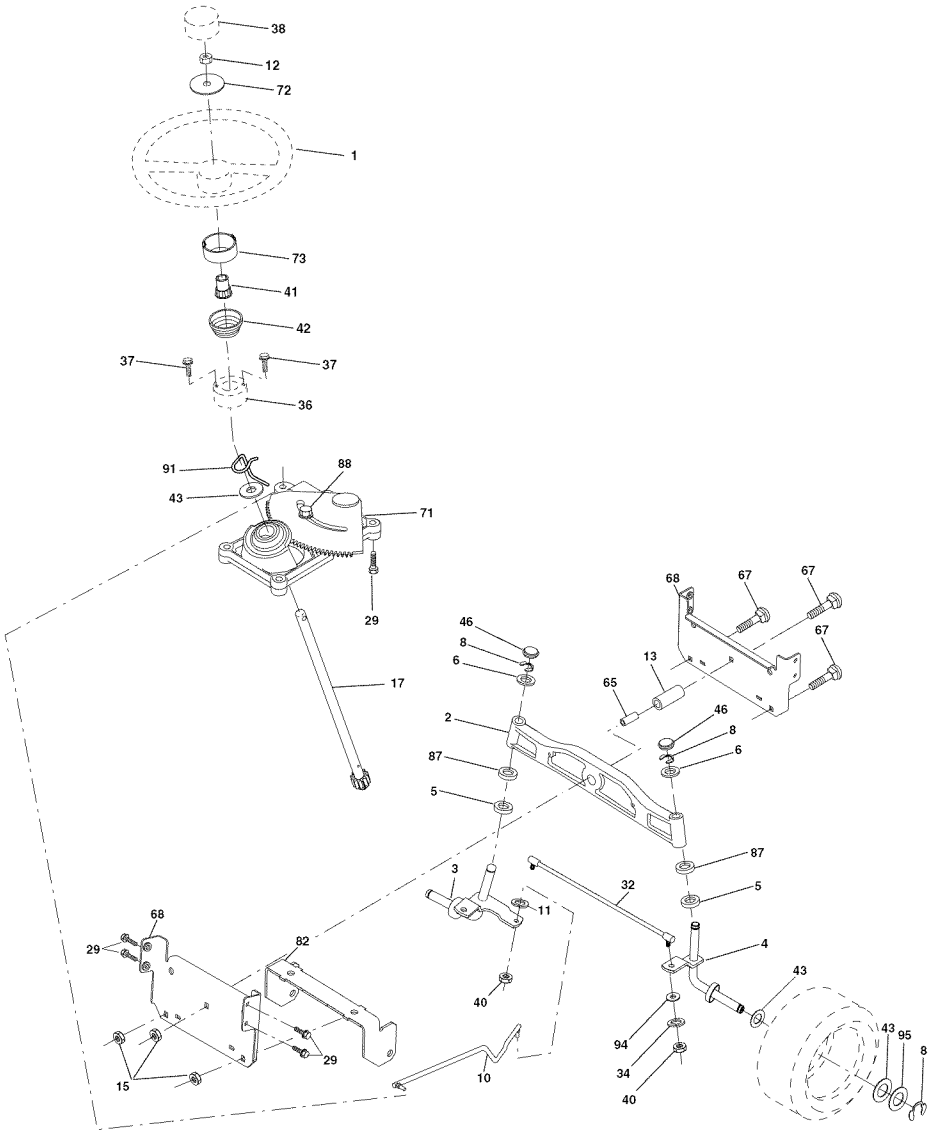

steering_stealth_prem_7

TRACTOR - - MODEL NUMBER 917.273631

STEERING

KEY NO.	PART NO.	DESCRIPTION
1	159944X428	Wheel Steering
2	184706	Axle Asm
3	169840	Spindle Asm LH
4	169839	Spindle Asm RH
5	6266H	Bearing Race Thrust Harden
6	121748X	Washer 25/32 x 1-5/8 x 16 Ga.
8	12000029	Ring Klip #t5304-75
10	175121	Link Drag
11	STD551137	Washer Lock Hvy Hlcl Spr 3/8
12	73940800	Nut Hex Jam Toplock 1/2-20 unf
13	136518	Spacer Bearing Axle Front
15	145212	Nut Hex Flange Lock
17	177883	Shaft Asm. Steering
29	17000612	Screw 3/8-16 x 3/4
32	171888	Rod Tie
34	10040500	Washer Lock 5/16
36	155105	Bushing Strg
37	152927	Screw
38	159946X428	Insert Cap Strg Wh
40	73540500	Crownlock Nut 5/16-24 unf
41	159945	Adaptor Wheel Strg
42	163888X428	Boot Steering
43	121749X	Washer 25/32 1 1/4 x 16 Ga.
46	184946X505	Cap Spindle
65	160367	Spacer Brace Axle
67	72110618	Bolt Rdhd Sqnk 3/8-16 x 2-1/4
68	169827	Axle, Brace
71	175146	Steering Asm.
72	19182411	Washer 9/16 ID x 1-1/2 OD 11 Ga.
73	160135X428	Extension Steering
82	169835	Bracket Susp. Chassis Front
87	173966	Washer Flat .781 x 1-1/2 x .15
88	175118	Bolt Shoulder 7/16-20 unc
91	175553	Clip Steering
94	19111216	Washer 11/32 x 3/4 x 16 Ga.
95	188967	Washer Hardened

NOTE: All component dimensions given in U.S. inches
1 inch = 25.4 mm

TRACTOR - - MODEL NUMBER 917.273631

ENGINE

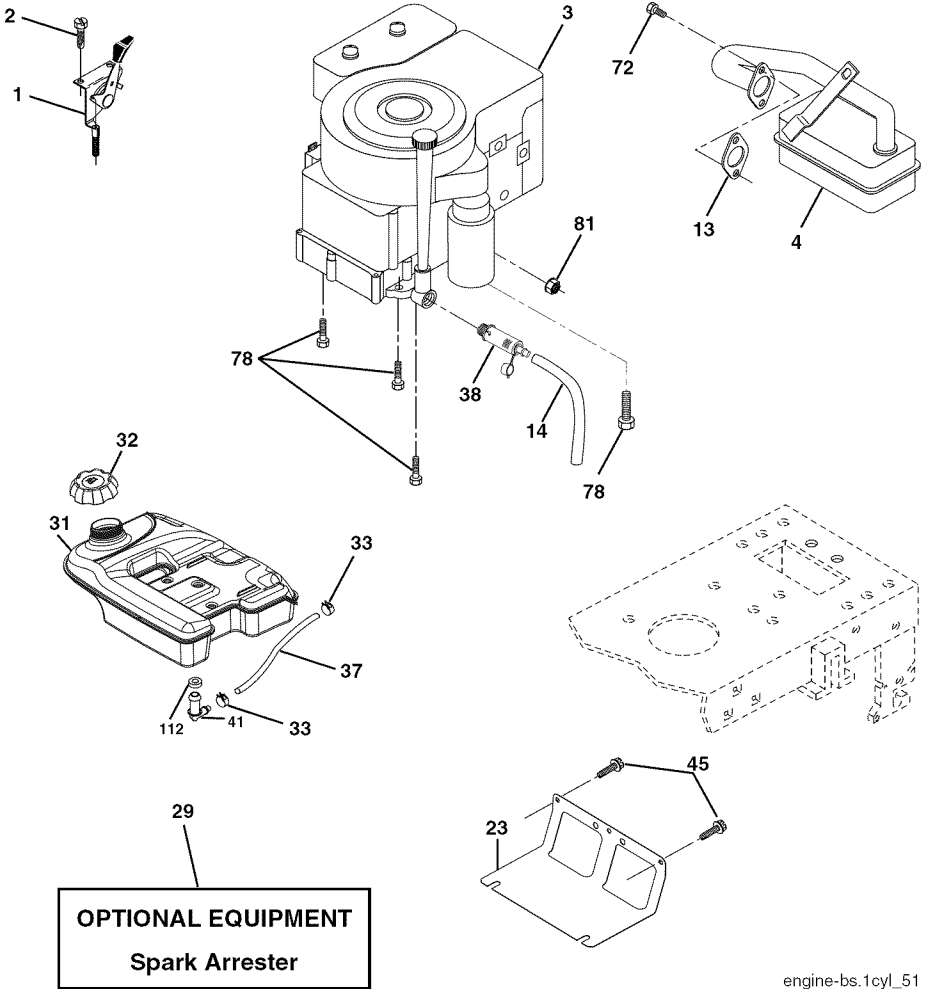

KEY NO.	PART NO.	DESCRIPTION
1	176636X505	Control Throttle
2	171875	Screw Hwhd Hi-Lo #13-16 x 3/4
3	- - - - -	Engine, Briggs Model 31P777-0348-E1 (See Breakdown)
4	137352	Muffler
13	165291	Muffler Gasket
14	148456	Tube Drain oil
23	169837	Shield Heat
29	137180	Kit Spark Arrestor (Flat Scrn)
31	179022	Tank Fuel 4.0 Rear
32	179124X428	Cap Asm Fuel
33	123487X	Clamp Hose Black
37	8543R	Line Fuel
38	181654	Plug Drain Oil Easy
41	139277	Stem Tank Fuel
45	17000612	Screw Hexwsh Thdr 3/8-16 x 3/4
72	183906	Screw 5/16-18 x 1
78	17060620	Screw 3/8-16 x 1-1/4
81	73510400	Nut Keps Hex 1/4-20 unc
112	3645J	Bushing

NOTE: All component dimensions given in U.S. inches
1 inch = 25.4 mm

TRACTOR - - MODEL NUMBER 917.273631

SEAT ASSEMBLY

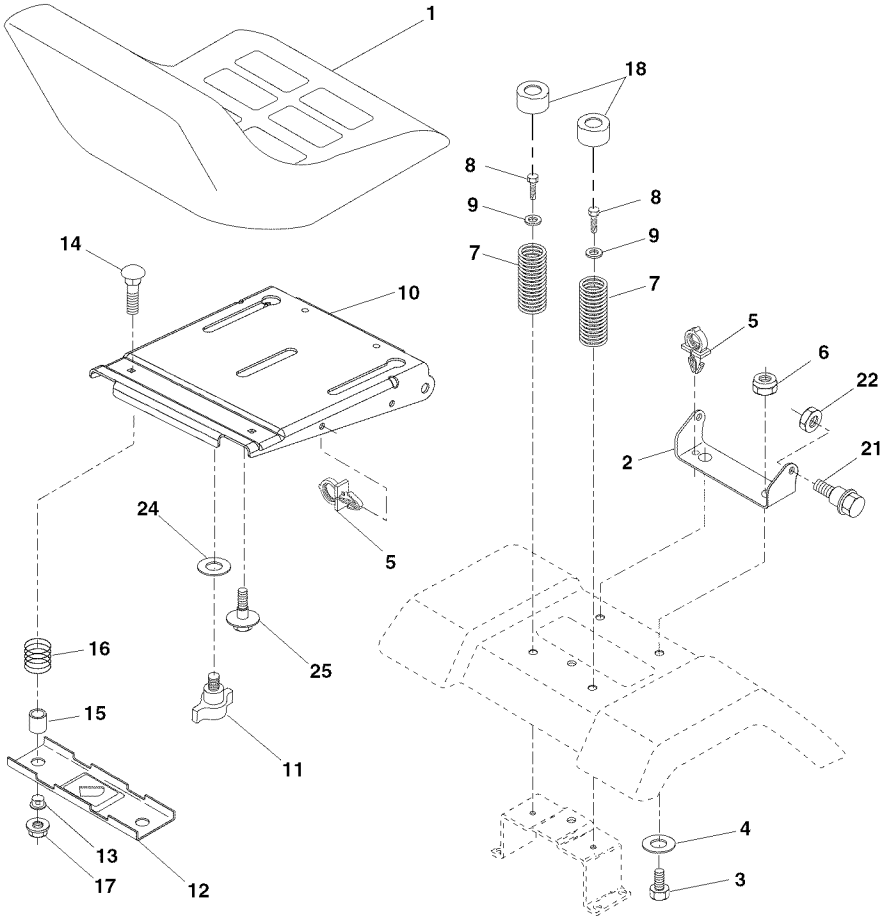

seat_ft.knob_14

KEY NO.	PART NO.	DESCRIPTION
1	180598	Seat
2	180166	Bracket Pivot Seat
3	STD523710	Bolt Fin Hex 3/8-16 unc x 1
4	19131610	Washer 13/32 x 1 x 10 Ga.
5	145006	Clip Push-In
6	STD541437	Nut Hex w/Ins. 3/8-16 unc
7	124181X	Spring Seat Cprsn
8	17000616	Screw 3/8-16 x 1-1/2
9	19131614	Washer 13/32 x 1 x 14 Ga.
10	180186	Pan Seat
11	166369	Knob Seat Adj. Wingnut
12	121246X	Bracket Mounting Switch

KEY NO.	PART NO.	DESCRIPTION
13	121248X	Bushing Snap Blk Nyl 50 Id
14	72050412	Bolt Rdhd Sqnk 1/4-20 x 1-1/2
15	121249X	Spacer Split 28x .88 Zinc
16	123740X	Spring Cprsn Plate 1.310 Ga.
17	123976X	Nut Lock 1/4 Lge Flg Gr. 5 Zinc
18	124238X	Cap Spring Seat
21	171852	Bolt Shoulder 5/16-18 unc
22	STD541431	Nut Hex Lock W/Ins 5/16-18
24	19171912	Washer 17/32 x 1-3/16 x 12 Ga.
25	127018X	Bolt Shoulder 5/16-18 x 62

NOTE: All component dimensions given in U.S. inches
1 inch = 25.4 mm

TRACTOR - - MODEL NUMBER 917.273631

DECALS

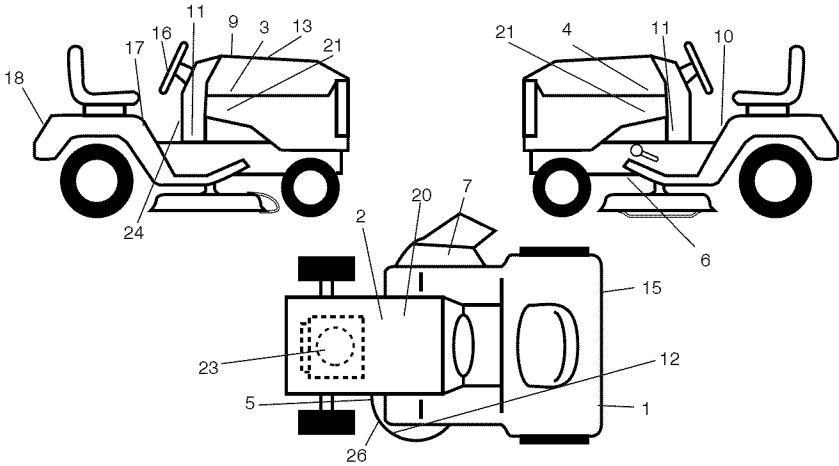

KEY PART NO. NO.

KEY PART NO.	NO.	DESCRIPTION
1	187407	Reflector, LH
2	138047	Decal, Battery, Diehard, Sears
3	186242	Decal, Hood RH
4	186243	Decal, Hood LH
5	160396	Decal, Deck Sch.
6	146046	Decal, V-Belt, Drive Schematic
7	179128	Decal, Deck "B" "42"
9	191053	Decal, Replacement Hood
10	156439	Decal, Fender, Danger
11	189088	Decal, Panel, Dash
12	172331	Decal, Mower, Heavy-Duty
13	133644	Decal, Replacement Parts
15	187408	Decal, Reflector, RH

KEY PART NO. NO.

KEY PART NO.	NO.	DESCRIPTION
16	164065	Decal, Steering Wheel
17	156368	Decal, Fender, Operator Instructions
18	186572	Decal, Fender
20	149516	Decal, Battery
21	186331	Decal, Hood, Side Panel
23	189020	Decal, Engine
24	164096	Decal, Dash
26	181470	Decal, Deck level
--	184310X428	Pad, Footrest, ST/LT, LH
--	184311X428	Pad, Footrest, ST/LT, RH
--	191054	Manual, Owner's, English
--	191055	Manual, Owner's, Spanish

WHEELS & TIRES

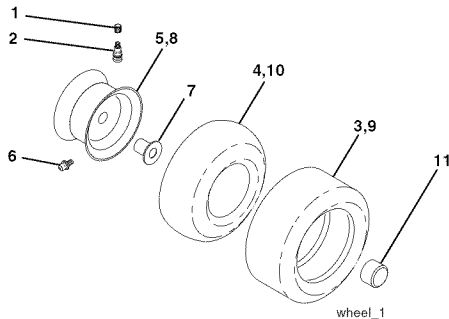

KEY PART NO. NO.

KEY PART NO.	NO.	DESCRIPTION
1	59192	Cap Valve Tire
2	65139	Stem Valve
3	106222X	Tire F Ts 15 x 6 0 - 6 Service
4	59904	Tube Front (Service Item Only)
5	106732X624	Rim Asm 6" front Service
6	278H	Fitting Grease (Front Wheel Only)
7	9040H	Bearing Flange (Front Wheel Only)
8	106108X624	Rim Asm 8" rear Service
9	122082X	Tire R Ts 20 x 10-8 C Service
10	7152J	Tube Rear (Service Item Only)
11	104757X428	Cap Axle
--	144334	Sealant, Tire (10 oz. Tube)

NOTE: All component dimensions given in U.S. inches
1 inch = 25.4 mm

TRACTOR - - MODEL NUMBER 917.273631
LIFT ASSEMBLY

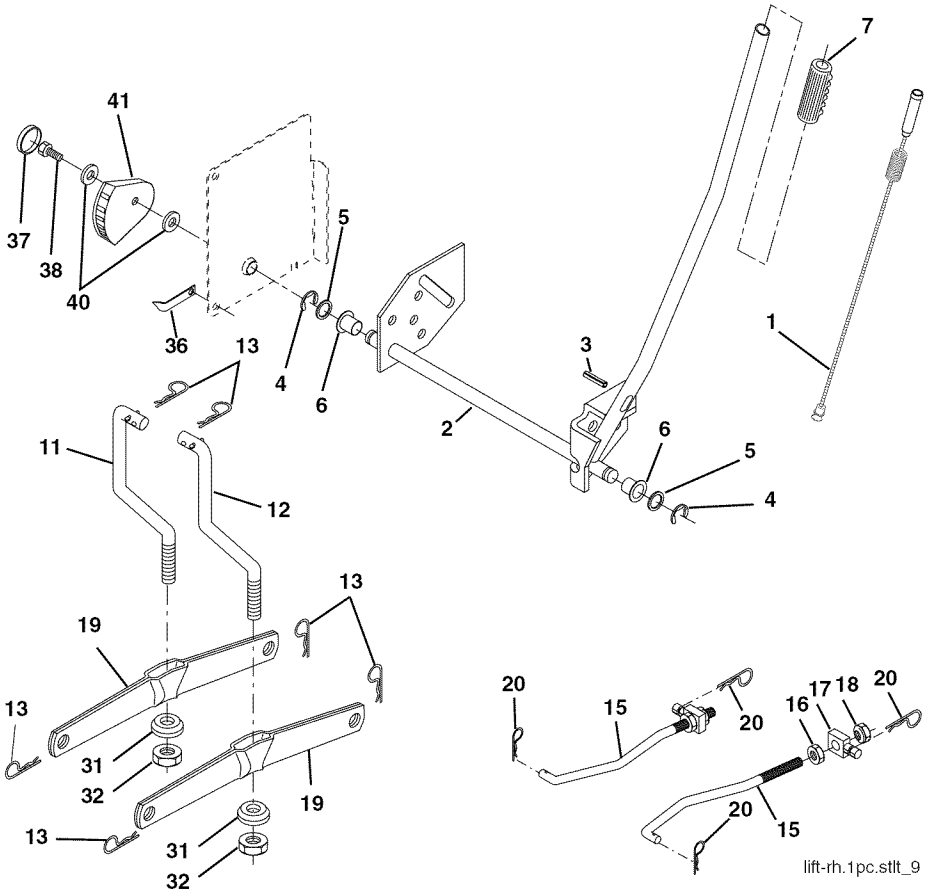

lift-rh.1pc.stlt_9

LIFT ASSEMBLY **TRACTOR - - MODEL NUMBER 917.273631**

KEY PART NO.	PART NO.	DESCRIPTION
1	179504	Plunger Assembly
2	159476	Shaft Assembly, Lift
3	178981	Pin, Groove
4	12000002	E-Ring
5	19211621	Washer 21/32 x 1 x 21 Ga.
6	120183X	Bearing, Nylon
7	175830	Grip, Handle, Fluted
11	139865	Link, Lift, L.H.
12	139866	Link, Lift, R.H.
13	STD624008	Retainer Spring
15	173288	Link, Front
16	73350800	Nut, Hex, Jam 1/2-13 unc
17	175689	Trunnion
18	73800800	Locknut, Hex, with Washer Insert 1/2-13 unc
19	139888	Arm, Suspension, Rear
20	163552	Retainer Spring
31	169865	Bearing, Pvt, Lift
32	73540600	Nut, Crownlock 3/8-24
36	155097	Pointer Height Indicator
37	123935X	Plug Hole
38	17060516	Screw 5/16-18 x 1
40	19112410	Washer 11/32 x 1-1/2 10 Ga.
41	155098	Indicator Height

NOTE: All component dimensions given in U.S. inches
1 inch = 25.4 mm

TRACTOR -- MODEL NUMBER 917.273631
 MOWER DECK

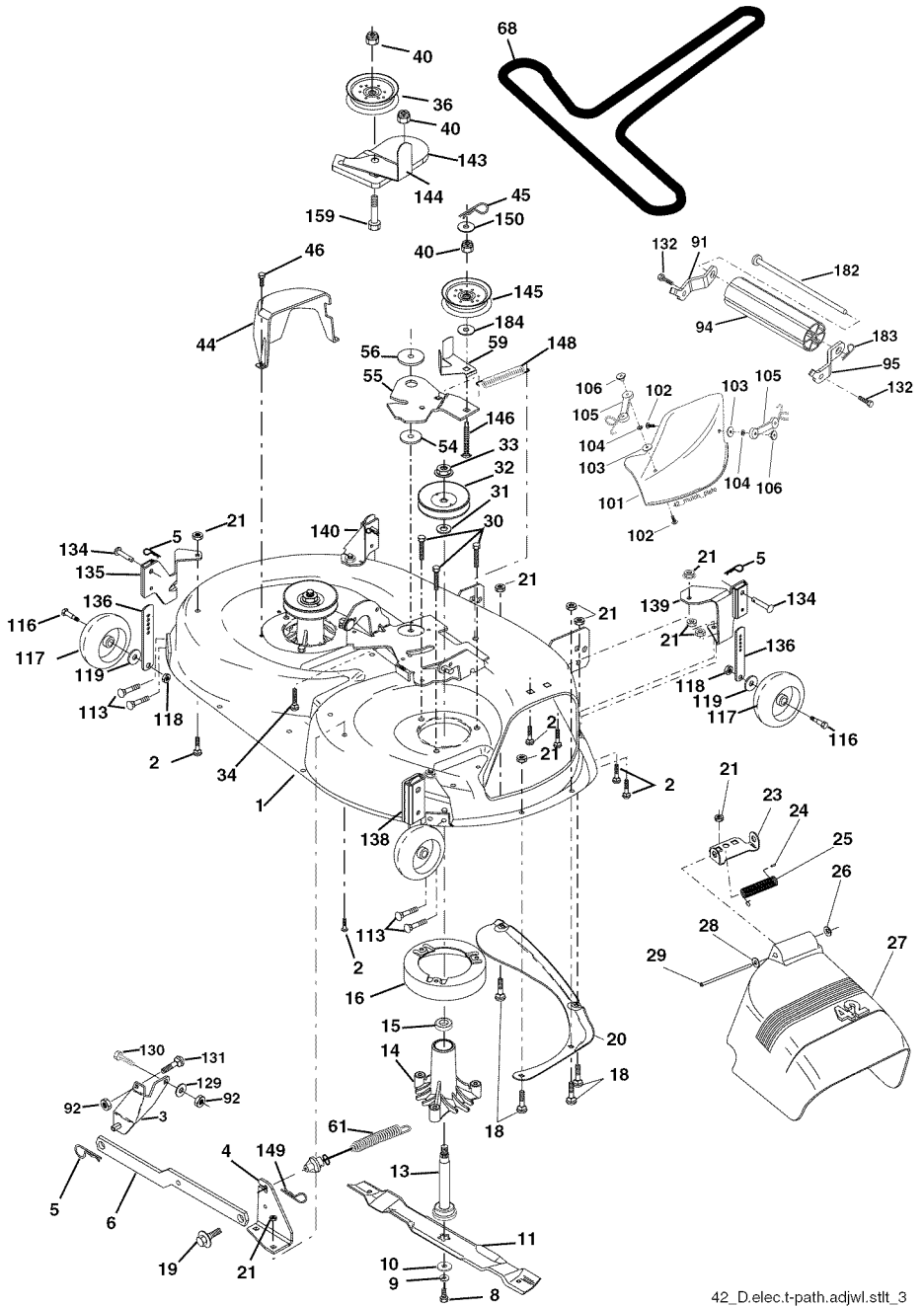

42_D_elec.t-path.adjwl.stlt_3

TRACTOR - - MODEL NUMBER 917.273631

MOWER DECK

KEY NO.	PART NO.	DESCRIPTION	KEY NO.	PART NO.	DESCRIPTION
1	182032	Mower Housing	95	180533	Bracket Roller Nose RH
2	STD533107	Bolt	101	136420	Cover Mulching 42" Black
3	138017	Bracket Assembly,Sway Bar, Fr.	102	71081010	Screw Truss Hd Phil10-24 x 5/8
4	165460	Bracket Sway Bar 38/42"	103	19061216	Washer #10
5	STD624008	Retainer Spring	104	STD551110	Washer Lock
6	178024	Bar Sway Deck	105	160793	Latch Asm Bagger
8	850857	Bolt, Hex 3/8-24 x 1.25 Gr. 8	106	2029J	Nut Weld
9	STD551137	Washer, Lock	113	17060512	Screw 5/16-18 x 3/4
10	140296	Washer, Hardened (The following blades are available)	116	4898H	Bolt, Shoulder
11	134149	Blade, 42" Mulching STD (For mulching mowers only)	117	165746	Wheel, Gauge
--	139775	Blade, 42" Mulching Premium (For better wear when mulching)	118	73930600	Nut, Crownlock 3/8-1
--	138971	Blade, 42" Hi-Lift (For bagging or discharge)	119	19121414	Washer 13/32 x 7/8 x 14 Ga.
13	137645	Shaft Assembly, Mandrel, Vented (Incl. Key Number 6)	129	19131312	Washer 13/32 x 13/16 x 12 Ga.
14	128774	Housing, Mandrel, Vented	130	STD523710	Bolt, Fin Hex 3/8-16 unc x 1 Gr. 5
15	110485X	Bearing, Ball, Mandrel	131	STD533710	Bolt Rdhd Sqnc 3/8-16 unc x 1
16	174493	Stripper, Mower Deck	132	17000612	Screw 3/8-16 x 3/4
18	72140505	Bolt, Carriage 5/16-18 x 5/8	134	156941	Pin Head Rivet
19	132827	Bolt, Shoulder	135	159765	Bracket Asm. Wheel Gauge Rear LH
20	159770	Baffle, Vortex	136	155986	Bar Adj. Gauge Wheel
21	STD541431	Nut, Crownlock 5/16-18 unc	138	159763	Bracket Asm. Wheel Gauge Rear RH
23	177563	Bracket, Deflector	139	159767	Bracket Asm. Wheel Gauge Front RH
24	105304X	Cap, Sleeve	140	159768	Bracket Asm. Wheel Gauge Front LH
25	123713X	Spring, Torsion, Deflector	143	157109	Bracket Arm Idler 42"
26	110452X	Nut, Push	144	158634	Keeper Belt 42" Clutch Cable
27	130968X428	Shield, Deflector	145	165888	Pulley Idler Flat
28	19111016	Washer 11/32 x 5/8 x 16 Ga.	146	171977	Bolt Carriage Idler
29	131491	Rod, Hinge	148	169022	Spring Return Idler
30	173984	Screw Thdrol Rolling Wsh Hd	149	165898	Retainer Spring Yellow Zinc
31	187690	Washer, Spacer	150	19091210	Washer 9/32 x 3/4 x 10 Ga.
32	153535	Pulley, Mandrel	152	169676	Cable Clutch 42"
33	178342	Nut, Toplock, Flanged	158	17720408	Screw Hex Thd Cut 1/4-20 x 5/8
34	72110612	Bolt Carr Sh. 3/8-16 x 1-1/2 Gr. 5	159	STD533717	Bolt Rdhd Sqnc 3/8-16 unc x 1-3/4
36	131494	Pulley, Idler, Flat	182	179126	Rod Roller Nose
40	73900600	Nut, Lock Flg. 3/8-16 unc	183	194209	Pin Cotter 7/16 Bow Tie Lock
44	140088	Guard, Mandrel, L.H.	184	19131410	Washer 3/8
45	STD624003	Retainer	185	188234	Head Asm Cable Clutch
46	137729	Screw, Thd. Roll 1/4-20 x 5/8	--	130794	Mandrel Assembly (Includes housing, shaft and shaft hardware only-pulley not included)
54	178515	Washer, Hardened	--	181542	Replacement Mower, Complete (Std. Deck-Order separately mulch cover, gauge wheels and nose roller components key nos. 101 - 106, 5, 116 - 119, 134, 136 and 91, 94, 95, 132, 182, 183)
55	155046	Arm, Idler			
56	165723	Spacer, Retainer			
59	141043	Guard, Tuv Idler (94)			
61	174882	Spring Ext Elect Clutch			
67	149846	Knob Custom Oval			
68	174883	V-Belt			
91	180532	Bracket Roller Nose LH			
92	STD541437	Locknut, Hex W/Wsh 3/8-16 unc			
94	132264	Roller Nose			

NOTE: All component dimensions given in U. S. inches 1 inch = 25.4 mm

TRACTOR - - MODEL NUMBER 917.273631
 DANA TRANSAXLE--MODEL NUMBER 4360 EMD

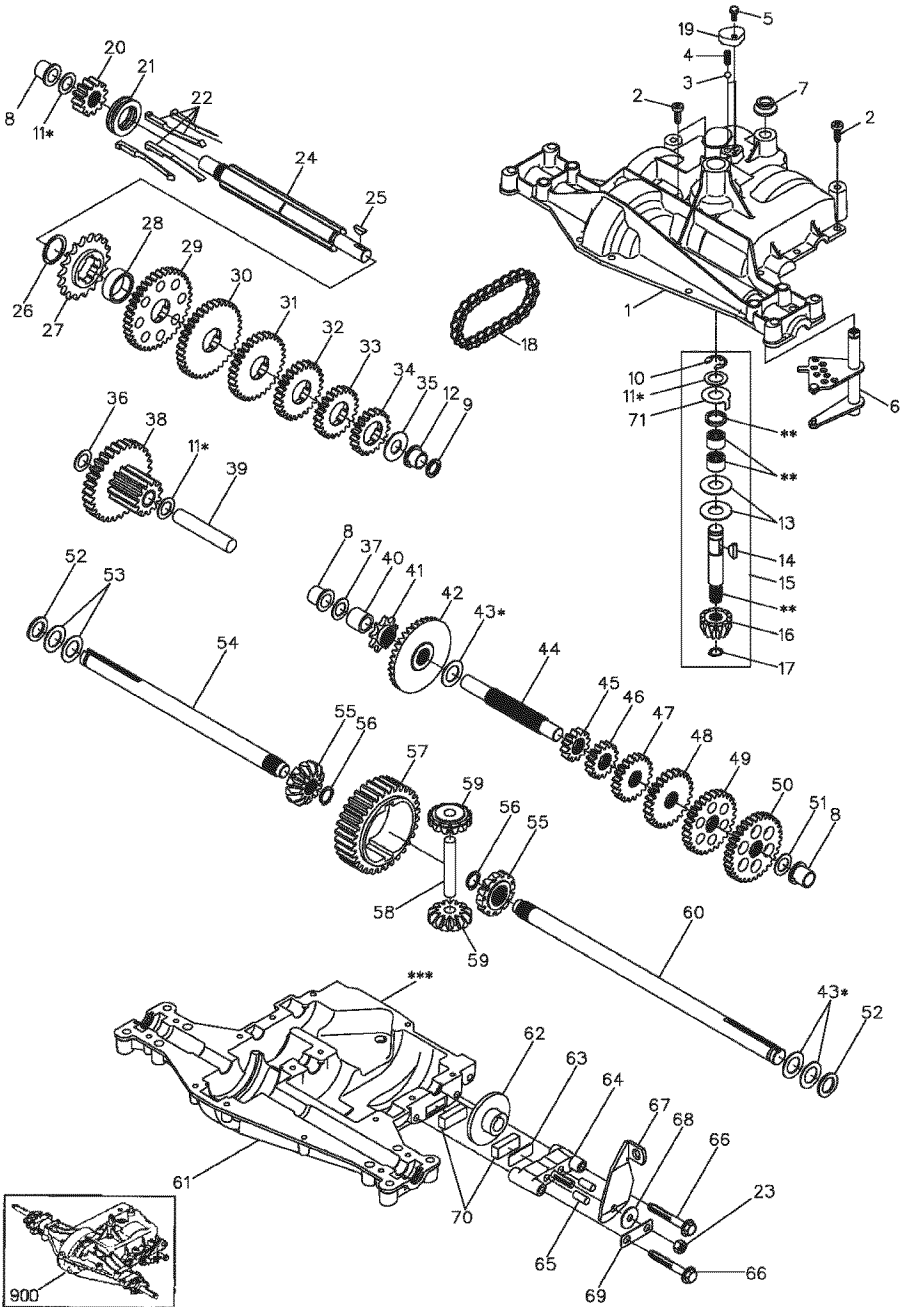

TRACTOR - - MODEL NUMBER 917.273631
DANA TRANSAXLE--MODEL NUMBER 4360 EMD

KEY NO.	PART NO.	DESCRIPTION	KEY NO.	PART NO.	DESCRIPTION
1	190972	Housing, Upper	41	105928X	Sprocket, 9T
2	2274J	Screw, Tapping, 1/4-20 X .734	42	190986	Gear, Bevel, 36T
3	190973	Ball, Detent	43	134394*	Assy, Kit, Shim, .750 Shaft
4	190974	Spring, Detent	44	120473X	Shaft, Drive
5	190975	Screw, Tapping, No. 10-24 X .482	45	142678	Gear, Spur, 12T
6	190977	Assy, Kit, Shifter	46	143697	Gear, Spur, 15T
7	190978	V-Ring	47	124641X	Gear, Spur, 20T
8	148266	Bearing, Flange	48	106589X	Gear, Spur, 25T
9	148269	Seal, Oil	49	120408X	Gear, Spur, 28T
10	2225J	Ring, Retaining	50	105937X	Gear, Spur, 31T
11	134793*	Assy, Kit, Shim, .625 Shaft	51	2226J	Washer, Plain, .632 X 1.00 X .060
12	148268	Bearing, Flange	52	134401	Washer, Neoprene
13	120415X	Washer, Plain, .632 X 1.38 X .046	53	2264J	Washer, Plain, .758 X 1.25 X .031
14	142674	Key, Woodruff, No. 606	54	160946	Axle, LH
15	190980	Assy, Kit, Input Shaft	55	190987	Gear, Miter, 12T, Splined
16	190981	Pinion, Bevel, 12T	56	160948	Ring, Retaining
17	105909X	Ring, Retaining	57	110071X	Gear, Spur, 32T
18	105910X	Chain, 24 Pitches	58	120952X	Shaft, Cross
19	190982	Cover, Detent	59	190988	Gear, Miter, 12T, Idler
20	160943	Gear, Spur, 12T	60	160950	Axle, RH
21	138246	Collar, Clutch	61	190990	Housing, Lower
22	190983	Assy, Kit, Clutch Keys	62	19992	Disc, Brake
23	73810500	Nut, Lock, 5/16-24	63	108989X	Spacer, Brake Puck
24	190984	Shaft, Intermediate	64	160952	Jaw, Brake
25	2244J	Key, Woodruff, No. 61	65	120954X	Pin, Dowel
26	105916X	Ring, Retaining	66	160953	Screw, Tapping, 5/16-18 X 2.35
27	120470X	Sprocket, 18T	67	138244	Lever, Actuating
28	110070X	Spacer, 1.131 X 1.45 X .494	68	108996X	Washer, Plain, .321 X 1.00 X .055
29	142677	Gear, Spur, 37T	69	160954	Bracket, Anti-Rotation
30	142681	Gear, Spur, 35T	70	120951X	Puck, Friction
31	124644X	Gear, Spur, 30T	71	190993	Washer, Anti Rotation
32	108980X	Gear, Spur, 25T	72	120416X	Grease
33	120406X	Gear, Spur, 22T	900	189115	Transaxle, Complete
34	134796	Gear, Spur, 19T			
35	105925X	Washer, Plain, .640 X 1.37 X .061	*		Use in various combinations to maintain proper clearances.
36	2228J	Washer, Plain, .632 X 1.00 X .046	**		Order Key No. 15.
37	3413J	Washer, Plain, .632 X 1.00 X .010	***		Silicone Sealant to be applied between Upper and Lower Housings (use Loctite Ultra Gray Silicone 5699 or equivalent).
38	190985	Assy, Gear, Comb., 12T & 30T			
39	124639X	Shaft, Idler			
40	120472X	Spacer, .633 X .87 X .755			

NOTE: All component dimensions given in U.S. inches
1 inch = 25.4 mm

TRACTOR - - MODEL NUMBER 917.273631
BRIGGS & STRATTON ENGINE-MODEL NUMBER 31P777, TYPE NUMBER 0348-E1

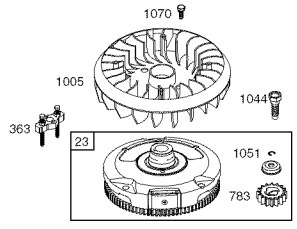
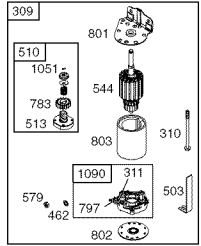
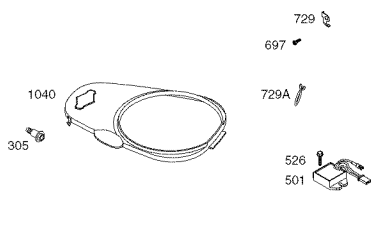
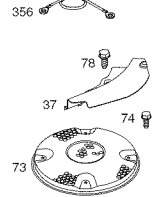
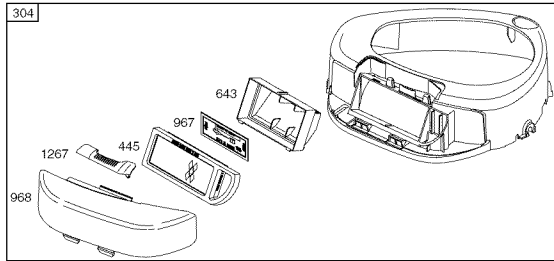
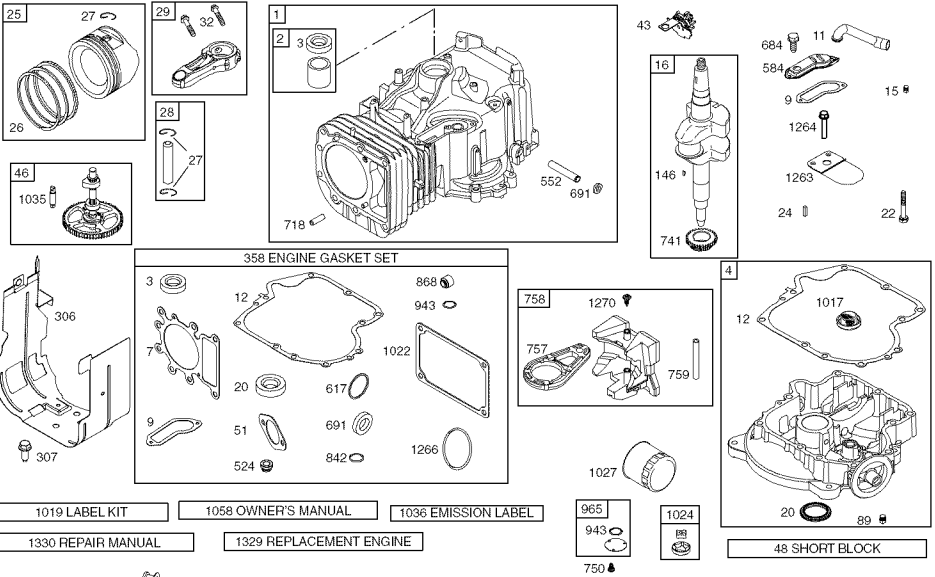

TRACTOR - - MODEL NUMBER 917.273631
BRIGGS & STRATTON ENGINE-MODEL NUMBER 31P777, TYPE NUMBER 0348-E1

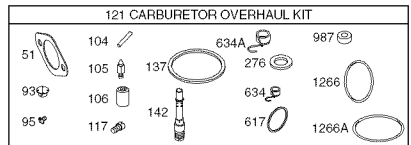
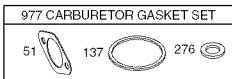
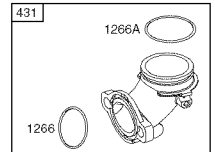
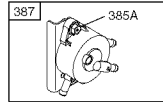
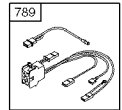
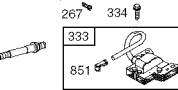
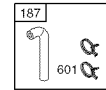
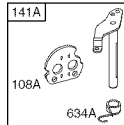
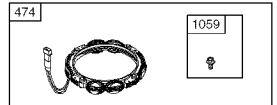
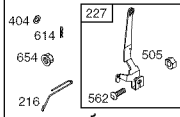
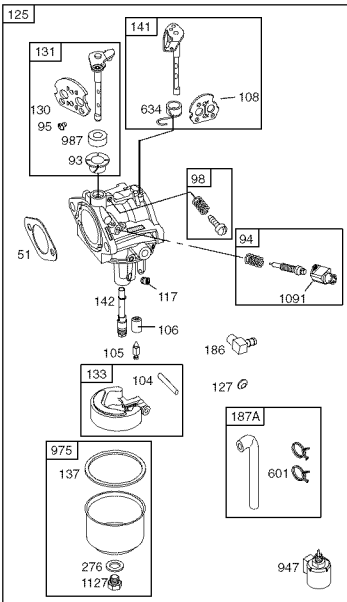
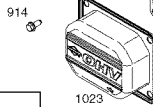
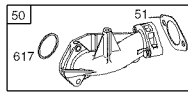
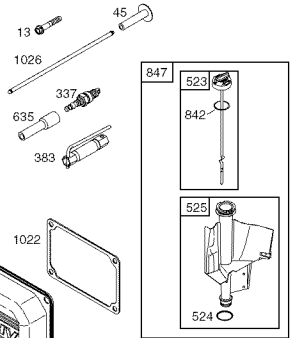
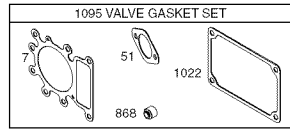
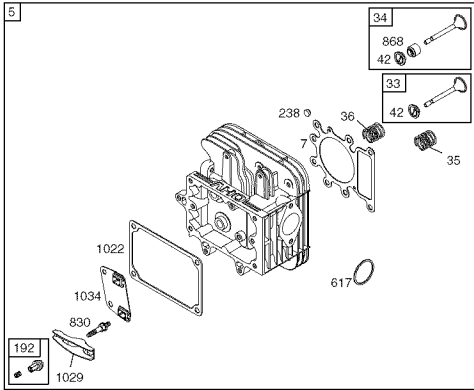

TRACTOR - - MODEL NUMBER 917.273631
BRIGGS & STRATTON ENGINE-MODEL NUMBER 31P777, TYPE NUMBER 0348-E1

KEY NO.	PART NO.	DESCRIPTION	KEY NO.	PART NO.	DESCRIPTION
1	697174	Cylinder Assembly	108	690464	Valve-Choke (Manual Choke)
2	399265	Kit-Bushing/Seal (MagnetoSide)	108A	692344	Valve-Choke (Choke A Matic)
3	391086	Seal-Oil (Magneto Side)	117	694352	Ø Jet-Main (Standard)
4	697188	Sump-Engine	118	697228	Jet-Main (High Altitude)
5	698147	Head-Cylinder	121	697241	Kit-Carburetor Overhaul
7	699168	+ Gasket-Cylinder Head	125	698445	Carburetor
9	697109	• Gasket-Breather	127	695005	Plug-Welch
11	697113	Tube-Breather	130	691750	Valve-Throttle
12	697110	• Gasket-Crankcase	131	494379	Kit-Throttle Shaft
13	690360	Screw (Cylinder Head)	133	494381	Floater-Carburetor
15	690946	Plug-Oil Drain	137	281165	Ø‡ Gasket-Floater Bowl
16	697127	Crankshaft	141	495097	Kit-Choke Shaft (Manual Choke)
20	690947	• Seal-Oil (PTO Side)	141A	495931	Kit-Choke Shaft (Choke A Matic)
22	692125	Screw (Crankcase CoverSump)	142	697140	Ø Nozzle-Carburetor
23	693556	Flywheel	146	691639	Key-Timing
24	222698	Key-Flywheel	186	698174	Connector-Hose
25	699052	Piston Assembly (Standard)	187	697098	Line-Fuel
	699054	Piston Assembly (.020" Oversize)	187A	698417	Line-Fuel
26	699051	Ring Set (Standard)	188	691693	Screw (Control Bracket)
	697559	Ring Set (.020" Oversize)	192	691986	Adjuster-Rocker Arm
27	698469	Lock-Piston Pin	202	691841	Link-Mechanical Governor
28	697099	Pin-Piston	209	692208	Spring-Governor
29	697126	Rod-Connecting (Standard)	216	691840	Link-Choke
	697263	Rod-Connecting (.020" Undersize)	222	694042	Bracket-Control
32	692852	Screw (Connecting Rod)	227	691374	Lever-Governor Control
33	695760	Valve-Exhaust	232	691842	Spring-Governor
34	695761	Valve-Intake	238	691843	Cap-Valve
35	691279	Spring-Valve (Intake)	240	691035	Filter-Fuel
36	691279	Spring-Valve (Exhaust)	265	691024	Clamp-Casing
37	697352	Guard-Flywheel	267	695134	Screw (Casing Clamp)
42	691752	Keeper-Valve	276	692255	Ø‡ Washer-Sealing
43	691968	Slinger-Governor/Oil	304	699829	Housing-Blower
45	690564	Tappet-Valve	305	697102	Screw (Blower Housing)
46	698492	Camshaft	305A	697103	Screw (Blower Housing)
48	697762	Short Block	306	697107	Shield-Cylinder
50	690193	Manifold-Intake	307	691003	Screw (Cylinder Shield)
51	692137	•Ø‡+ Gasket-Intake	309	693551	Motor-Starter
53	690227	Stud (Carburetor)	310	690323	Bolt (Starter Motor)
54	691148	Screw (Intake Manifold)	311	497608	Brush Set
73	697133	Screen-Rotating	333	492341	Armature-Magneto
74	697897	Screw (Rotating Screen)	334	691061	Screw (Magneto Armature)
78	691003	Screw (Flywheel Guard)	337	691043	Plug-Spark
89	690283	Plug-Oil	356	697089	Wire-Stop
93	690602	Ø Bushing-Throttle Shaft	358	697191	Gasket Set-Engine
94	498030	Kit-Idle Mixture	363	19203	Flywheel Puller
95	691636	Screw (Throttle Valve)	•		Included in Engine Gasket Set, Key. No. 358
98	495800	Kit-Idle Speed	Ø		Included in Carburetor Overhaul Kit, Key. No. 121
104	690525	Ø Pin-Floater Hinge	‡		Included in Carburetor Gasket Set, Key. No. 977
105	231855	Ø Valve-Floater Needle	+		Included in Valve Gasket Set, Key. No. 1095
106	691780	Ø Seat-Inlet			

NOTE: All component dimensions given in U.S. inches
1 inch = 25.4 mm

TRACTOR - - MODEL NUMBER 917.273631
BRIGGS & STRATTON ENGINE-MODEL NUMBER 31P777, TYPE NUMBER 0348-E1

KEY NO.	PART NO.	DESCRIPTION	KEY NO.	PART NO.	DESCRIPTION
383	89838	Wrench-Spark Plug	868	690968 *	Seal-Valve
385	694476	Screw (Fuel Pump)	914	690960	Screw (Rocker Cover)
385A	690297	Screw (Fuel Pump)	918	697091	Line-Vacuum
387	697090	Pump-Fuel	943	690589 •	Seal-O Ring (Oil Pump Cover)
404	691691	Washer (Governor Crank)	947	694393	Solenoid-Fuel
431	697122	Elbow-Intake	965	499613	Cover-Oil Pump
445	697153	Filter-Air Cleaner Cartridge	967	697015	Filter-Pre Cleaner
462	691261	Washer (Starter Cable)	968	699848	Cover-Air Cleaner
474	696459	Alternator	975	495933	Bowl-Float
501	691188	Regulator	977	690192	Gasket Set-Carburetor
503	691532	Strap-Starter	987	691326 Ø	Seal-Throttle Shaft
505	691251	Nut (Governor Control Lever)	1005	699043	Fan-Flywheel
510	693699	Drive-Starter	1017	690770	Screen-Oil Pump
513	692024	Clutch-Drive	1019	697143	Kit-Label
523	697086	Dipstick	1022	272475 *	Gasket-Rocker Cover
524	691032 •	Seal-Dipstick Tube	1023	692492	Cover-Rocker Arm
525	697085	Tube-Dipstick	1024	499054	Pump-Oil
526	697088	Screw (Regulator)	1026	692003	Rod-Push (Intake)
544	692034	Starter-Armature	--	692011	Rod-Push (Exhaust)
552	697144	Bushing-Governor Crank	1027	696854	Filter-Oil
562	691119	Bolt (Governor Control Lever)	1029	691751	Arm-Rocker
579	691029	Nut (Starter Cable)	1034	690822	Guide-Push Rod
584	697112	Cover-Breather Passage	1035	693784	Shaft-Pump
601	95162	Clamp-Hose	1036	695700	Label-Emission
614	691620	Pin-Cotter	1040	699852	Plate-Trim
616	692012	Crank-Governor	1044	698139	Screw (Flywheel)
617	692138 Ø •	Seal-O Ring (Intake Manifold)	1051	691265	Ring-Retaining
634	690801 Ø	Spring/Seal Assembly (Manual Choke)	1058	275038	Owner's Manual
634A	690802 Ø	Spring/Seal Assembly (Choke A Matic)	1059	698516	Kit-Screw/Washer
635	691909	Boot-Spark Plug	1070	690372	Screw (Flywheel Fan)
643	698401	Retainer-Air Filter	1090	691293	Retainer-Brush
654	690958	Nut (Carburetor)	1091	691333	Cap-Limiter
684	697157	Screw (Breather Passage Cover)	1095	690190	Gasket Set-Valve
691	692407 •	Seal-Governor Shaft	1119	691183	Screw (Alternator)
697	690372	Screw (Drive Cap)	1127	691657	Screw (Float Bowl)
718	690959	Pin-Locating	1263	697124	Reed-Breather
729	691224	Clip-Wire	1264	697104	Screw (Breather Reed)
729A	694123	Clip-Wire	1266	691917 •Ø	Seal-O Ring (Intake Elbow)
741	697128	Gear-Timing	1266A	697123 Ø	Seal-O Ring (Intake Elbow)
750	691033	Screw (Oil Pump Cover)	1267	697424	Latch-Blower Housing
757	697607	Link-Counterweight	1270	697156	Plug-AVS Counterweight
758	697134	Counterweight	1329	31Q777-0036	Replacement Engine
759	697392	Pin-Counterweight	1330	272147	Repair Manual
783	693713	Gear-Pinion	•		Included in Engine Gasket Set, Key. No. 358
789	698329	Harness-Wiring	Ø		Included in Carburetor Overhaul Kit, Key. No. 121
797	693167	Nut (Brush Retainer)	‡		Included in Carburetor Gasket Set, Key. No. 977
801	691283	Cap-Drive	+		Included in Valve Gasket Set, Key. No. 1095
802	691286	Cap-End			
803	693757	Housing-Starter			
830	691095	Stud (Rocker Arm)			
842	691031 •	Seal-O Ring (Dipstick Tube)			
847	697087	Dipstick/Tube Assembly			
851	692424	Terminal-Spark Plug			

NOTE: All component dimensions given in U.S. inches
1 inch = 25.4 mm

SERVICE NOTES

SUGGESTED GUIDE FOR SIGHTING SLOPES FOR SAFE OPERATION

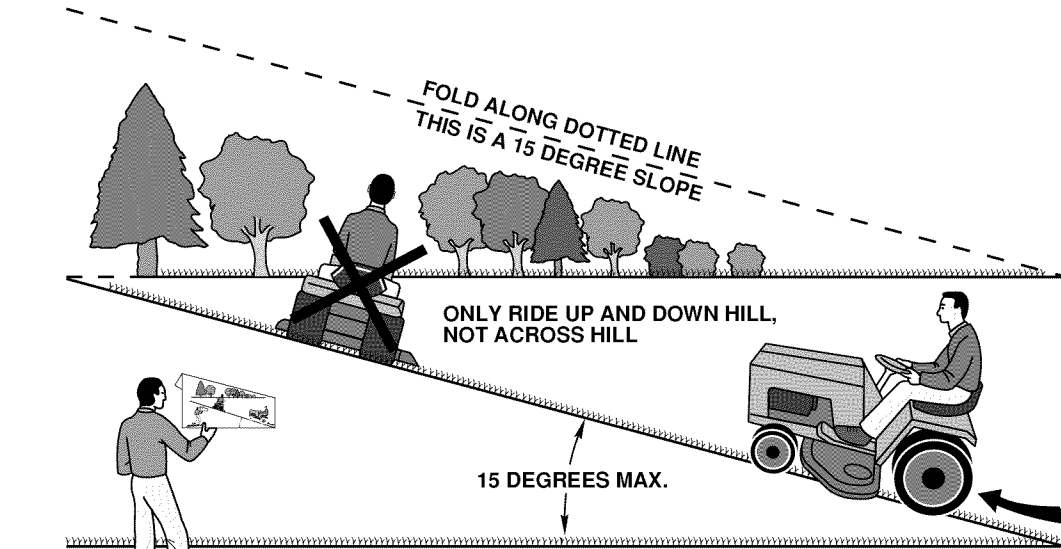

WARNING: To avoid serious injury, operate your tractor up and down the face of slopes, never across the face. Do not mow slopes greater than 15 degrees. Make turns gradually to prevent tipping or loss of control. Exercise extreme caution when changing direction on slopes.

1. Fold this page along dotted line indicated above.
2. Hold page before you so that its left edge is vertically parallel to a tree trunk or other upright structure.
3. Sight across the fold in the direction of hill slope you want to measure.
4. Compare the angle of the fold with the slope of the hill.

Get it fixed, at your home or ours!

Your Home

For repair – **in your home** – of **all** major brand appliances, lawn and garden equipment, or heating and cooling systems, **no matter who made it, no matter who sold it!**

For the replacement parts, accessories and owner's manuals that you need to do-it-yourself.

For Sears professional installation of home appliances and items like garage door openers and water heaters.

1-800-4-MY-HOME[®] Anytime, day or night
(1-800-469-4663) (U.S.A. and Canada)
www.sears.com **www.sears.ca**

Our Home

For repair of carry-in products like vacuums, lawn equipment, and electronics, call or go on-line for the nearest **Sears Parts and Repair Center.**

1-800-488-1222 Anytime, day or night (U.S.A. only)
www.sears.com

To purchase a protection agreement (U.S.A.) or maintenance agreement (Canada) on a product serviced by Sears:

1-800-827-6655 (U.S.A.) **1-800-361-6665** (Canada)

Para pedir servicio de reparación a domicilio, y para ordenar piezas:

1-888-SU-HOGARSM
(1-888-784-6427)

Au Canada pour service en français:

1-800-LE-FOYER^{MC}
(1-800-533-6937)
www.sears.ca

SEARS

02410

© Sears, Roebuck and Co.

© Registered Trademark / TM Trademark / SM Service Mark of Sears, Roebuck and Co.

© Marca Registrada / TM Marca de Fábrica / SM Marca de Servicio de Sears, Roebuck and Co.

^{MC} Marque de commerce / ^{MD} Marque déposée de Sears, Roebuck and Co.