

Pedestal Installation Instructions

Instructions d'installation du socle

Instrucciones de instalación del pedestal

Components

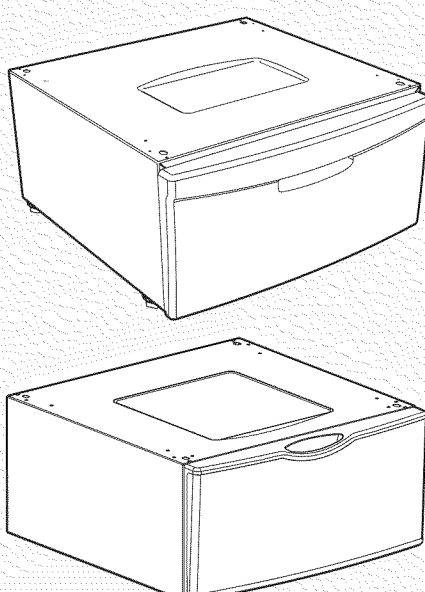

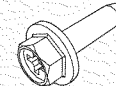

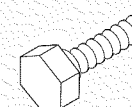
X4 **A**  6002-001313

X4 **B**  DC60-40017A

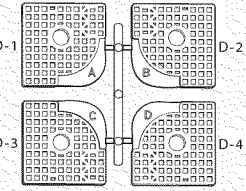
X4 **C**  DC60-60044A

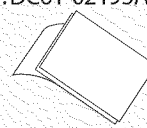
X1 **D**  D-1: DC61-01811A GUIDE-LEG (A)
D-2: DC61-01812A GUIDE-LEG (B)
D-3: DC61-02194A GUIDE-LEG (C)
D-4: DC61-02195A GUIDE-LEG (D)

X4 **E**  0203-002150

X4 **F**  DC61-01813B

X5 **G** 

Tools

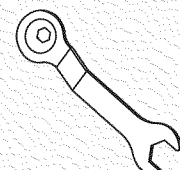

Wrench
Supplied with Washing
Machine or General Wrench
(9/16inch or 14mm)

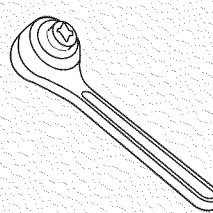

Socket Wrench
[11/16 inch, or 17mm]

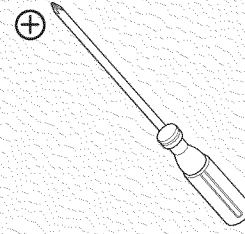

Phillips Screwdriver

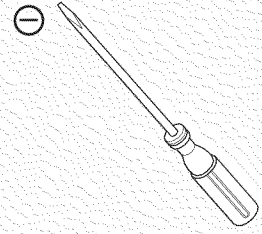

Flat Screwdriver

- ▶ The entire assembly procedures are followed as described below.
Assemble a riser and washer (or dryer) → remove shipping bolts → instal a washer (or dryer).
While installing a riser, keep the shipping blots tightened securely.
- ▶ Les procédures complètes d'assemblage doivent être exécutées dans cet ordre :
Assemblage d'un réhausseur et d'un lave-linge (ou sèche-linge) → retrait des vis de transport → installation d'un lave-linge (ou sèche-linge).
Lors de l'installation d'un réhausseur, laissez les vis de transport bien serrées.
- ▶ Los procedimientos de armado se siguen según se describe a continuación.
Monte una tubería vertical y una lavadora (o secadora) → quite los tornillos de transporte → instale una lavadora (o secadora).
Mantenga los tornillos de transporte bien ajustados al instalar una tubería vertical.

Code No. : DC68-02436A-05

- 1 -

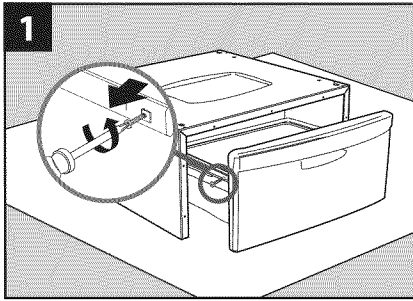

- Remove the screw with a Phillips screwdriver and the drawer.
- Retirez la vis à l'aide d'un tournevis Phillips puis retirez le tiroir.
- Quite el tornillo con un destornillador Phillips y saque el cajón.

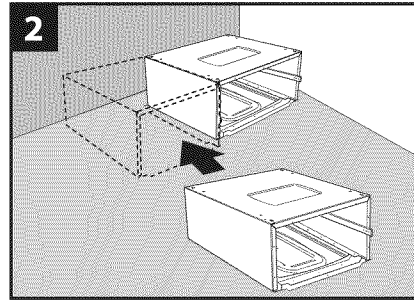

- Clean the floor for the installation and put the pedestal on the edge of the floor.
- Nettoyez l'endroit où l'appareil sera installé et placez-y le socle.
- Limpie el suelo donde va hacer la instalación y ponga el pedestal en su ubicación final.

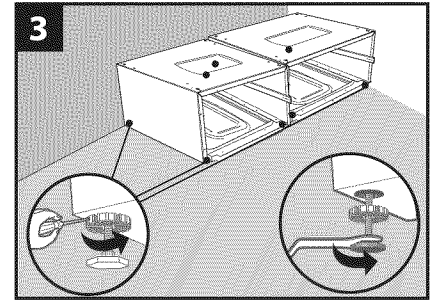

- (A) Level it with a wrench and (b) tighten up the lock nut with a flat screw driver.
- (A) Mettez-le à niveau à l'aide d'une clé anglaise puis (b) serrez l'écrou de blocage à l'aide d'un tournevis plat.
- (A) Nivelar con una llave inglesa y (b) ajustar las contratuercas con un destornillador de punta plana.

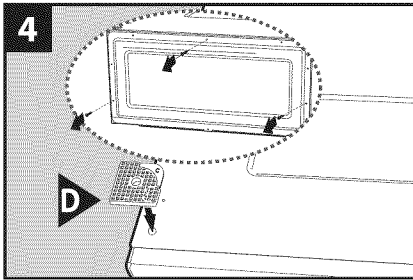

- Remove the screws (3ea) on the back panel.
- Retirez les vis (3ea) de l'écran noir.
- Quite los tornillos (3 ea) del panel posterior.

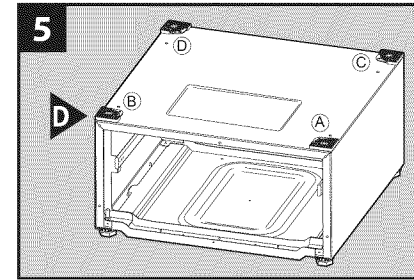

- Snap the guide-leg into the hole on the frame.
- Enfoncez le pied de guidage dans le trou prévu dans le cadre.
- Encaje la pata guía en el orificio del marco.

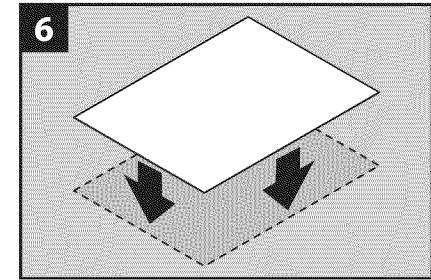

- Put a soft pad (cardboard) on the floor to prevent scratches during installation.
- Pendant l'installation, protégez le sol des griffures, par exemple avec un carton.
- Ponga algo blando (un cartón) en el suelo para evitar rayaduras durante la instalación.

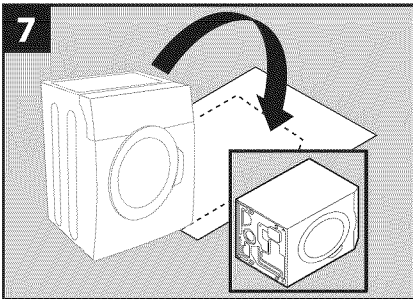

- Put Washer/Dryer on the soft pad.
- ▲ For the pedestal installation, the shipping bolts at the back of the washer shall not be removed. Remove them after putting the unit back to its upright position (at Step 10).
- Placez le lave-linge/sèche-linge sur la protection.
- ▲ Pour l'installation du socle, les vis de transport situées à l'arrière du lave-linge ne doivent pas être retirées. Ne les enlevez qu'une fois que l'appareil est replacé en position verticale (à l'étape 10).
- Coloque la lavadora o secadora sobre el cartón.
- ▲ Para la instalación del pedestal, los tornillos de transporte de la parte posterior de la lavadora no se deben quitar. Qúitelos después de poner la parte posterior de la unidad en su posición vertical (en el paso 10).

- Installation for Dryer, go to step 7a.
- Pour l'installation du séchoir, reportez-vous à l'étape 7a.
- Instalación de la secadora, ir al paso 7a.

- Installation for Washer, go to step 7b.
- Pour l'installation du lave-linge, reportez-vous à l'étape 7b.
- Instalación de la lavadora, ir al paso 7b.

Dryer / Nouvelle sècheuse Secadora

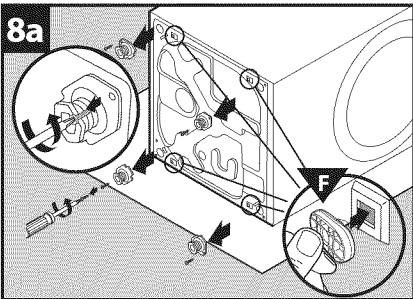

- Remove the leg assemblies (4ea) and snap the Bracket-screw into the holes (4ea).
- Retirez les piètements (4ea) et enfoncez les caches carrés dans les orifices (4ea).
- Quite los montajes de las patas (4ea) y encaje los tapones cuadrados en sus orificios (4ea).

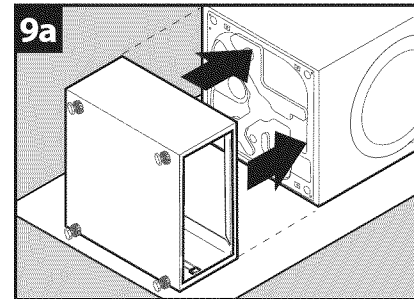

- Put the pedestal on the bottom.
- Placez le socle en bas.
- Ponga el pedestal en la parte inferior.

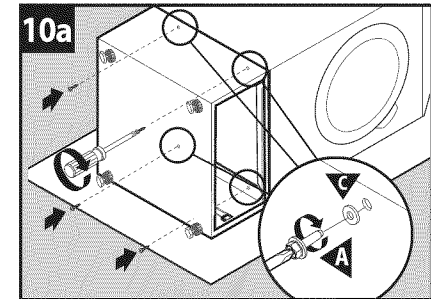

- Secure them with screws (4ea). Go to Step 10.
- Fixez-les à l'aide de vis (4ea). Passez à l'étape 10.
- Asegúrelo con los tornillos (4ea). Vaya al paso 10.

Washer /Laveuse/ Lavadora

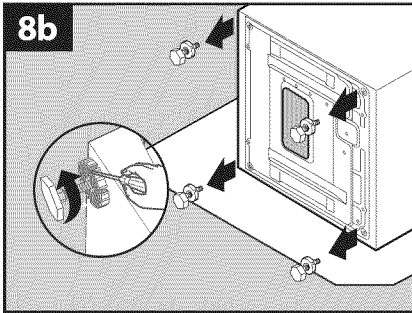

- Remove the leg assemblies (4ea).
- Otez les piètements (4ea).
- Quite los montajes de las patas (4ea).

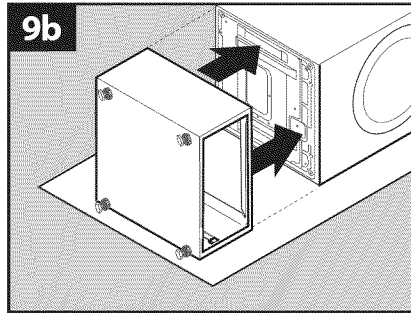

- Put the pedestal on the bottom.
- Placez le socle en bas.
- Ponga el pedestal en la parte inferior.

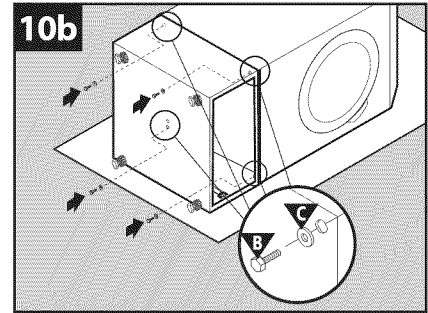

⚠ Caution / Attention / Precaución

- Make sure to tighten up all the bolts between the washer and the pedestal until you cannot be tightened up anymore.
→ **Use a socket wrench.**
- Veillez à serrer à fond tous les boulons entre le lave-linge et le support.
→ **Utilisez une clé à douille.**
- Asegúrese de ajustar bien todos los pernos entre la lavadora y el pedestal hasta que no se los pueda ajustar más.
→ **Use una llave de cubo.**

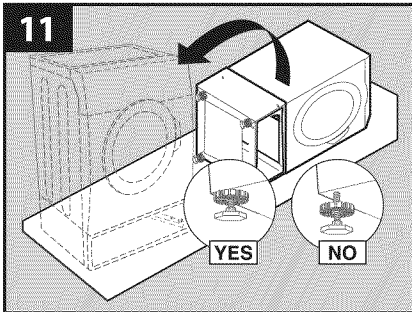

- Put the assembled unit back to upright position.
- Remplacez l'appareil en position verticale.
- Ponga la parte posterior de la unidad ensamblada en posición vertical.

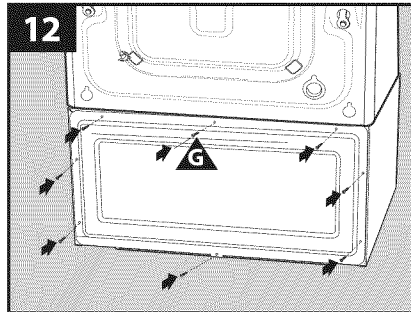

- Screw up (8ea) the back panel.
- ⚠ Make sure all the screws are completely fastened to prevent buzzing noise during unit operation.
- Fixez le panneau arrière à l'aide de vis (8ea).
- ⚠ Assurez-vous que toutes les vis sont correctement serrées afin d'éviter tout bourdonnement pendant le fonctionnement.
- Atornille (8ea) el panel posterior.
- ⚠ Asegúrese de que todos los tornillos estén bien apretados para evitar ruidos de zumbidos durante el funcionamiento.

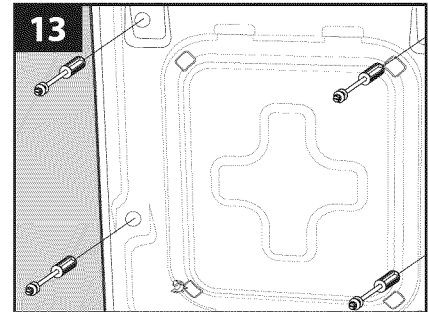

- Remove the Shipping bolts of washing machine
- Retirez les vis de transport du lave-linge.
- Quite los tornillos de transporte de la lavadora.

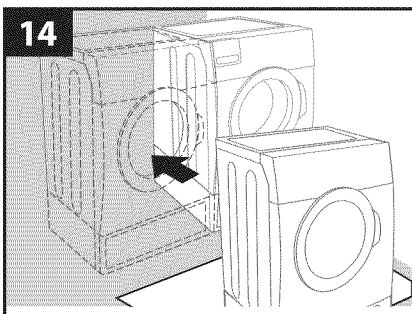

- Put the assembled units to the installation sites.
- Posez les appareils assemblés à leur place définitive.
- Ponga las unidades ensambladas en el lugar de instalación.

Tips for Wooden Panel Floor and Vibration Test / Conseils pour les sols en bois et Test de vibration / Consejos para los suelos de paneles de madera y test de vibraciones

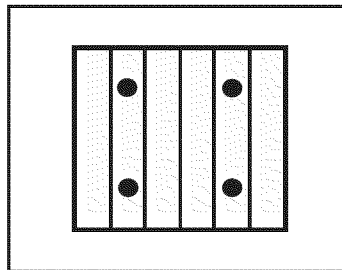

- Put the legs on the same floor panels and keep them away from the floor lines.
- Placez les pieds sur les mêmes panneaux de parquet, entre les rainures.
- Ponga las patas sobre los mismos paneles del suelo y apártelas de las líneas del suelo.

- Test-1.
- Put it into the Spin cycle and check its vibration.
 - Mettez-le en cycle Essorage et contrôlez ses vibrations.
 - Seleccione el ciclo Spin (Centrifugado) y verifique si hay vibraciones.
- Test-2.
- If there is too much vibration, repeat the above.
 - S'il y a trop de vibrations, répétez les opérations ci-dessus.
 - Si hay demasiadas vibraciones, repita los pasos anteriores.

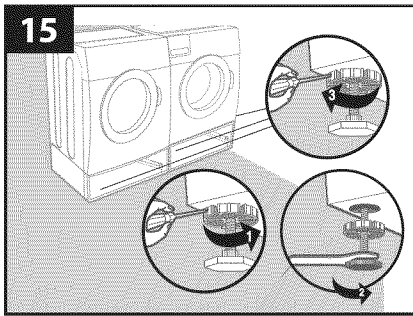

- Check leveling and when needed, do additional leveling.
- Vérifiez qu'ils sont à niveau.
- Controle el nivel y, si es necesario, haga los ajustes precisos..

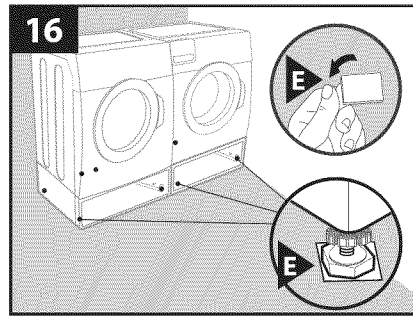

- Peel out the double-face tape. Attach it under the all legs.
- Décollez la bande autocollante double face. Collez-la sous tous les pieds.
- Pele una cinta de doble cara. Péguela bajo todas las patas.

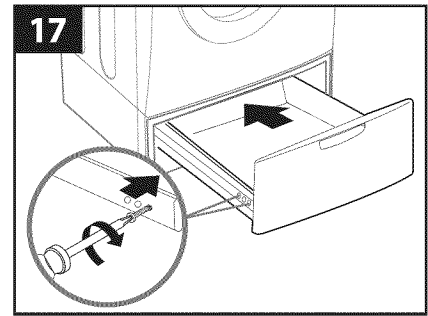

- Slide the drawer back in and secure them with screws in step 1.
- Remplacez le tiroir.
- Vuelva a poner el cajón.

Notice/Aviso/Avis

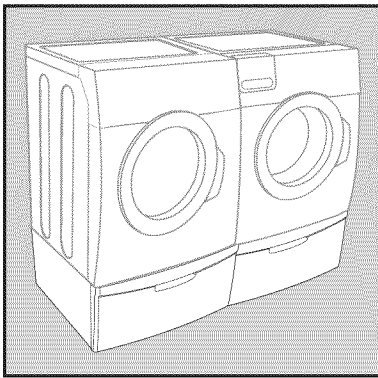

Notice:

Vibration is a normal result of unbalanced/extreme load conditions and should diminish as the machine automatically compensates for the unbalanced load. Do not attempt to manipulate or adjust the machine as it is going through this process.

Aviso:

La vibración es el resultado normal de las condiciones en las que la carga está desequilibrada o es excesiva, y deberá disminuir a medida que la máquina compensa automáticamente la carga desequilibrada. No trate de manipular o ajustar la máquina durante este proceso.

Avis:

Lorsqu'une charge est mal équilibrée ou très importante, il est normal que l'appareil vibre et cette vibration devrait diminuer au fur et à mesure que l'appareil compense automatiquement pour la charge mal équilibrée. Ne pas tenter de manipuler ou de régler l'appareil pendant que ce processus est en cours.

Warranty

SAMSUNG LAUNDRY PEDESTAL LIMITED WARRANTY TO ORIGINAL PURCHASER

This SAMSUNG brand product, as supplied and distributed by SAMSUNG ELECTRONICS AMERICA, INC.

(SAMSUNG) and delivered new, in the original carton to the original consumer purchaser, is warranted by SAMSUNG against manufacturing defects in materials and workmanship for a limited warranty period of:

One (1) Year All Parts and Labor

This limited warranty begins on the original date of purchase, and is valid only on products purchased and used in the United States. To receive warranty service, the purchaser must contact SAMSUNG for problem determination and service procedures. Warranty service can only be performed by a SAMSUNG authorized service center. The original dated bill of sale must be presented upon request as proof of purchase to SAMSUNG or SAMSUNG's authorized service center. SAMSUNG will provide in-home service during the warranty period at no charge, subject to availability within the contiguous United States.

In-home service is not available in all areas.

To receive in-home service, product must be unobstructed and accessible to the service agent. If service is not available, SAMSUNG may elect to provide transportation of the product to and from an authorized service center.

SAMSUNG will repair, replace, or refund this product at our option and at no charge as stipulated herein, with new or reconditioned parts or products if found to be defective during the limited warranty period specified above. All replaced parts and products become the property of SAMSUNG and must be returned to SAMSUNG. Replacement parts and products assume the remaining original warranty, or ninety (90) days, whichever is longer. This limited warranty covers manufacturing defects in materials and workmanship encountered in normal, noncommercial use of this product and shall not apply to the following: damage that occurs in shipment; delivery and installation; applications and uses for which this product was not intended; altered product or serial numbers; cosmetic damage or exterior finish; accidents, abuse, neglect, fire, water, lightning, or other acts of nature or God; use of products, equipment, systems, utilities, services, parts, supplies, accessories, applications, installations, repairs, external wiring or connectors not supplied or authorized by SAMSUNG that damage this product or result in service problems; incorrect electrical line voltage, fluctuations and surges; customer adjustments and failure to follow operating instructions, maintenance and environmental instructions that are covered and prescribed in the instruction book; product removal and reinstallation; problems caused by pest infestations. This limited warranty does not cover problems resulting from electric current, voltage or supply, light bulbs, house fuses, house wiring, cost of a service call for instructions, or fixing installation errors. SAMSUNG does not warrant uninterrupted or error-free operation of the product.

EXCEPT AS SET FORTH HEREIN, THERE ARE NO WARRANTIES ON THIS PRODUCT EITHER EXPRESS OR IMPLIED, AND SAMSUNG DISCLAIMS ALL WARRANTIES INCLUDING, BUT NOT LIMITED TO, ANY IMPLIED WARRANTIES OF MERCHANTABILITY, INFRINGEMENT OR FITNESS FOR A PARTICULAR PURPOSE. NO WARRANTY OR GUARANTEE GIVEN BY ANY PERSON, FIRM, OR CORPORATION WITH RESPECT TO THIS PRODUCT SHALL BE BINDING ON SAMSUNG. SAMSUNG SHALL NOT BE LIABLE FOR LOSS OF REVENUE OR PROFITS, FAILURE TO REALIZE SAVINGS OR OTHER BENEFITS, OR ANY OTHER SPECIAL, INCIDENTAL OR CONSEQUENTIAL DAMAGES CAUSED BY THE USE, MISUSE, OR INABILITY TO USE THIS PRODUCT, REGARDLESS OF THE LEGAL THEORY ON WHICH THE CLAIM IS BASED, AND EVEN IF SAMSUNG HAS BEEN ADVISED OF THE POSSIBILITY OF SUCH DAMAGES. NOR SHALL RECOVERY OF ANY KIND AGAINST SAMSUNG BE GREATER IN AMOUNT THAN THE PURCHASE PRICE OF THE PRODUCT SOLD BY SAMSUNG AND CAUSING THE ALLEGED DAMAGE. WITHOUT LIMITING THE FOREGOING, PURCHASER ASSUMES ALL RISK AND LIABILITY FOR LOSS, DAMAGE, OR INJURY TO PURCHASER AND PURCHASER'S PROPERTY AND TO OTHERS AND THEIR PROPERTY ARISING OUT OF THE USE, MISUSE, OR INABILITY TO USE THIS PRODUCT. THIS LIMITED WARRANTY SHALL NOT EXTEND TO ANYONE OTHER THAN THE ORIGINAL PURCHASER OF THIS PRODUCT, IS NONTRANSFERABLE AND STATES YOUR EXCLUSIVE REMEDY.

Some states do not allow limitations on how long an implied warranty lasts, or the exclusion or limitation of incidental or consequential damages, so the above limitations or exclusions may not apply to you. This warranty gives you specific rights, and you may also have other rights, which vary from state to state.

To obtain warranty service, please contact SAMSUNG at:

SAMSUNG ELECTRONICS AMERICA, INC. – CONSUMER ELECTRONICS CUSTOMER SERVICE 400 Valley Road, Suite 201, Mt. Arlington, NJ 07856

1-800-SAMSUNG (1-800-726-7864)

www.samsung.com