

Use & Care Guide

Model No.

153.331010 25 U.S. Gal (94.6 Litres)
For installation at elevations from 0-3,500 ft. (0-1,067m).

153.331000 HA 25 U.S. Gal (94.6 Litres)
For installation at elevations from 3,501 - 6,500 ft. (1,067 - 1,981m).



Kenmore Elite®

Hybrid Gas Water Heater

For potable water heating only.
Not suitable for space heating.
Not for use in mobile homes.

INSTALLER: Affix these instructions to or near the water heater.

OWNER: Retain these instructions for future reference.

FOR YOUR SAFETY: An odorant is added to the gas used by this water heater.

IMPORTANT: For installations above 3,500 feet above sea level, verify the proper high altitude water heater model is installed or the proper circuit board has been ordered and installed. See High Altitude section of manual for further details.

P/N 320169-001 (0611)

Sears Brands Management Corporation,
Hoffman Estates, IL 60179 U.S.A.
www.kenmore.com
www.sears.com




WARNING: If the information in these instructions is not followed exactly, a fire or explosion may result causing property damage, personal injury or death.





- Do not store or use gasoline or other flammable vapors and liquids in the vicinity of this or any other appliance.
- **WHAT TO DO IF YOU SMELL GAS:**
 - Do not try to light any appliance.
 - Do not touch any electrical switch; do not use any phone in your building.
 - Immediately call your gas supplier from a neighbor's phone. Follow the gas supplier's instructions.
 - If you cannot reach your gas supplier, call the fire department.
- Installation and service must be performed by a qualified installer, service agency or the gas supplier.

SAFE INSTALLATION, USE AND SERVICE

Your safety and the safety of others is extremely important in the installation, use and servicing of this water heater.

Many safety-related messages and instructions have been provided in this manual and on your own water heater to warn you and others of a potential injury hazard. Read and obey all safety messages and instructions throughout this manual. It is very important that the meaning of each safety message is understood by you and others who install, use or service this water heater.

	<p>This is the safety alert symbol. It is used to alert you to potential personal injury hazards. Obey all safety messages that follow this symbol to avoid possible injury or death.</p>
---	---

	<p>DANGER indicates an imminently hazardous situation which, if not avoided, will result in injury or death.</p>
	<p>WARNING indicates a potentially hazardous situation which, if not avoided, could result in injury or death.</p>
	<p>CAUTION indicates a potentially hazardous situation which, if not avoided, could result in minor or moderate injury.</p>
	<p>CAUTION used without the safety alert symbol indicates a potentially hazardous situation which, if not avoided, could result in property damage.</p>

All safety messages will generally tell you about the type of hazard, what can happen if you do not follow the safety message and how to avoid the risk of injury.


The California Safe Drinking Water and Toxic Enforcement Act requires the Governor of California to publish a list of substances known to the State of California to cause cancer, birth defects, or other reproductive harm, and requires businesses to warn of potential exposure to such substances.


- **WARNING:** This product contains a chemical known to the State of California to cause cancer, birth defects, or other reproductive harm.
- This appliance can cause low-level exposure to some of the substances listed in the act.

IMPORTANT DEFINITIONS

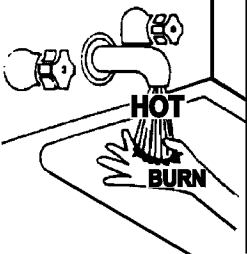
- **Qualified Installer or Service Agency:** Installation and service of this water heater requires ability equivalent to that of a Qualified Agency (as defined by ANSI below) in the field involved. Installation skills such as plumbing, air supply, venting, gas supply, electrical supply are required in addition to electrical testing skills when performing service.
- **ANSI Z223.1 2006 Sec. 3.3.83:** “Qualified Agency” - “Any individual, firm, corporation or company that either in person or through a representative is engaged in and is responsible for (a) the installation, testing or replacement of gas piping or (b) the connection, installation, testing, repair or servicing of appliances and equipment; that is experienced in such work; that is familiar with all precautions required; and that has complied with all the requirements of the authority having jurisdiction.”
- **Gas Supplier:** The Natural Gas or Propane Utility or service who supplies gas for utilization by the gas burning appliances within this application. The gas supplier typically has responsibility for the inspection and code approval of gas piping up to and including the Natural Gas meter or Propane storage tank of a building.

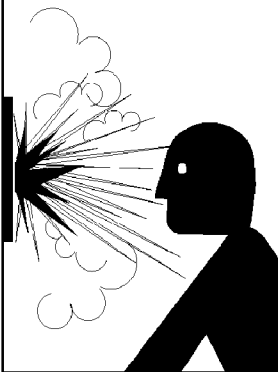
GENERAL SAFETY



	⚠ WARNING
	<p>Read and understand instruction manual and safety messages before installing, operating or servicing this water heater.</p> <p>Failure to follow instructions and safety messages could result in death or serious injury.</p> <p>Instruction manual must remain with water heater.</p>

	⚠ WARNING
	Fire Hazard <p>For continued protection against risk of fire:</p> <ul style="list-style-type: none">• Do not install water heater on carpeted floor.• Do not operate water heater if flood damaged.

⚠ DANGER	<p>Water temperature over 125°F (52°C) can cause severe burns instantly resulting in severe injury or death.</p> <p>Children, the elderly, and the physically or mentally disabled are at highest risk for scald injury.</p> <p>Feel water before bathing or showering.</p> <p>Temperature limiting valves are available.</p> <p>Read instruction manual for safe temperature setting.</p>
-----------------	--



	⚠ WARNING
	Explosion Hazard <ul style="list-style-type: none">• Overheated water can cause water tank explosion.• Properly sized temperature and pressure relief valve must be installed in opening provided.

⚠ WARNING	
Fire or Explosion Hazard	
<ul style="list-style-type: none">• Do not store or use gasoline or other flammable vapors and liquids in the vicinity of this or any other appliance.• Avoid all ignition sources if you smell gas.• Do not expose water heater control to excessive gas pressure.• Use only gas shown on rating plate.• Maintain required clearances to combustibles.• Keep ignition sources away from faucets after extended period of non-use.	
	<p>Read instruction manual before installing, using or servicing water heater.</p>
	

GENERAL SAFETY

CAUTION

Improper Installation, use and service may result in property damage.

- Do not operate water heater if flood damaged.
- Inspect anode rods regularly, replace when significantly depleted.
- Install in location with drainage.
- Fill tank with water before operation.
- Properly sized thermal expansion tanks are required on all closed water systems.

Refer to this manual for installation and service.

⚠ WARNING

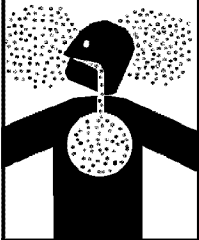


- Before servicing the water heater, make sure the water heater is unplugged from the electrical supply.
- Label all wires prior to disconnection when servicing controls. Wiring error can cause improper and dangerous operation. Verify proper operation after servicing.
- Failure to do this could result in death, serious bodily injury, or property damage.

⚠ WARNING

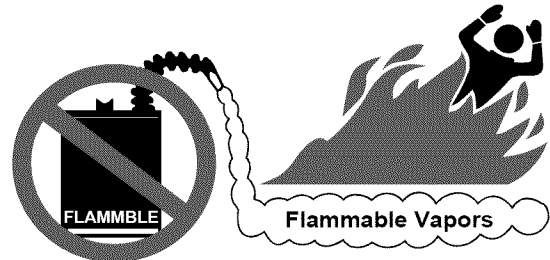
Breathing Hazard - Carbon Monoxide Gas

- Install vent system in accordance with codes.
- Do not operate water heater if flood damaged.
- Standard model is fitted for operation at altitudes up to 3,500 ft. (1,067m). High Altitude model is suitable for altitudes between 3,501 to 6,500 ft. (1,067m and 1,981m). Specific accessory kits are required for installations above 6,500 ft. (1,981m).
- Do not operate if soot buildup is present.
- Do not obstruct water heater air intake with insulating jacket.
- Do not place chemical vapor emitting products near water heater.
- Gas and carbon monoxide detectors are available.
- No vent damper installation is compatible with this power vented water heater.
- Do not elevate the condensate hose on the bottom of the water heater above the bracket attached to the side of the unit. This must be true for the entire length of the hose including the exit into an appropriate drain.
- Condensate lines must be free and clear of debris and must not allow back flow through the hose. The condensate lines must be able to flow freely to an appropriate drain.
- Do not allow condensate lines to become crimped closed.
- Analyze the entire vent system to make sure that condensate will not become trapped in a section of vent pipe and therefore reduce the open cross sectional area of the vent.



Breathing carbon monoxide can cause brain damage or death. Always read and understand instruction manual.

⚠ DANGER



⚠ Vapors from flammable liquids may explode and catch fire causing death or severe burns.

Do not use or store flammable products such as gasoline, solvents or adhesives in the same room or area near the water heater.

Keep flammable products:

1. far away from heater,
2. in approved containers,
3. tightly closed and
4. out of children's reach.

Water heater has a main burner and spark generator. The spark generator:

1. can be triggered at any time and
2. the spark will ignite flammable vapors.

Vapors:

1. cannot be seen,
2. are heavier than air,
3. go a long way on the floor and
4. can be carried from other rooms to the electrodes by air currents.

Installation: Do not install the water heater where flammable products will be stored or used. It must be installed a minimum of 18 in. (45cm) above the floor if installed in a residential garage. This will reduce, but not eliminate, the risk of flammable vapors being ignited by the main burner or spark igniter.

TABLE OF CONTENTS

SAFE INSTALLATION, USE AND SERVICE	2	OPERATING INSTRUCTIONS	34
GENERAL SAFETY	3	Display Panel	34
PRODUCT WARRANTY	6	Wiring Diagram	36
INTRODUCTION	8	Lighting Instructions	37
Get To Know Your Water Heater - Gas Models	9	Temperature Regulation	38
INSTALLATION CONSIDERATIONS	10	Unique Hybrid Features	39
Rough In Dimensions	10	Temperature Regulation	41
Water Piping - Mixing Valve Usage	12	Constant Output Temperature Control	42
Facts To Consider About Location	13	Start Up Conditions	42
Handle Installation	14	Operational Conditions	42
Earthquake Zones	15	MAINTENANCE	43
Combustion Air And Ventilation	17	Housekeeping	43
Appliances In Unconfined Spaces	17	Venting System Inspection	43
Appliances In Confined Spaces	17	Flood Damage	43
Chemical Vapor Corrosion	19	Anode Rod Inspection	43
Water Piping	19	Anode Rod Replacement	44
Closed Water Systems	19	Temperature-pressure Relief Valve Operation	44
Thermal Expansion	19	Motors	44
Hard Water	20	Snow Accumulation	45
Temperature-pressure Relief Valve	20	Cleaning The Inlet Water Filter	45
Gas Piping	22	Cleaning The Heat Engine	45
Sediment Traps	22	Flushing The Heat Exchanger (Lime Build-up)	45
Gas Line Purging	23	Draining The Tank	46
High Altitude Installations	23	Fault Indication And Error Codes	46
Flooding/freezing	23	Diagnostic Display	47
Filling The Water Heater	23	TROUBLESHOOTING	52
Venting	24	Service	54
Vent Pipe Techniques	24	Leakage Checkpoints	54
Planning The Vent System	25	Replacement Parts	55
Installation Of Vent System	26	Parts Identification	57
Vent Terminal Installation, Sidewall	26	Notes	58
Installation Of Vent System, Sidewall	27		
Installation Of Vertical Vent System	28		
Vent Pipe Preparation	28		
Connection To Vent Pipe	31		
Condensate	31		
US. Power Vent	32		
Electrical Connections	33		
Calibration	33		

Fill out and keep with water heater.

IMPORTANT INFORMATION

Model Number _____

Serial Number _____

Installation Information:

Date Installed _____

Company's Name _____

Street or P.O. Box _____

City, State, and Zip Code _____

Phone Number _____ Plumber's Name _____

PRODUCT WARRANTY

Kenmore Elite® Hybrid Gas Water Heater Warranty

For six years from the date of purchase, if this water heater is installed and operated in a single-family home in accordance with the owner's manual instructions and all local applicable plumbing codes, Sears will:

1. Supply free water heater parts for those that are defective in material or workmanship.
2. Supply a free water heater for one that develops a tank leak. See notes below also.

For the second through sixth year from the purchase date, you must pay the labor cost for installation of parts or water heater.

For commercial, institutional, industrial or residential use by two or more families, the above limited warranty is only for one year.

If governmental regulations prohibit Sears from furnishing a comparable model replacement water heater under this warranty, Sears will furnish a new water heater of comparable output as permitted by such governmental regulations; however, the Owner will be charged for the additional cost associated with the changes made to comply with such governmental regulations.

Replacements furnished under this warranty do not carry a new warranty and are only covered by the unexpired portion of the original warranty.

CONDITIONS AND EXCEPTIONS

This warranty shall apply only when the water heater is installed and operated in accordance with 1) all local fire codes and plumbing codes, ordinances, and regulations. 2) the printed instructions provided with it, 3) good industry practices, and 4) proper safety practices such as but not limited to a properly sized drain pan if installed in an area where leakage from connections of the tank would result in damage to the area adjacent to the heater. In addition, a new temperature and pressure relief valve, certified by the Canadian Standards Association must have been properly installed and piped to the nearest drain.

This warranty shall apply only when the heater is:

- not subjected to excessive water pressure fluctuations and not subject to an operating pressure greater than 150 P.S.I.
- filled with potable water, free to circulate at all times and with the tank free of damaging water sediment or scale deposits.
- used in a non-corrosive and non-contaminated atmosphere.
- sized in accordance with proper sizing techniques for residential water heaters.
- bearing a rating plate which has not been altered, defaced or removed.
- used in an open system or in a closed system with a properly sized and installed thermal expansion tank.
- fired at the factory rated input using the fuel stated on the face of the rating plate.
- operated with the inner and outer doors in place.
- maintained in accordance with the instructions printed in the manual included with the heater.
- used in a water supply with less than 12 grains per gallon (200 mg/L) of hardness, is not acidic or otherwise impure.

Problems resulting from scale formation are not covered by the warranty.

Any accident to the water heater or any part thereof (including freezing, fire, floods, or lightning), any misuse, abuse, or alteration of it, any operation of it in a modified form, or any attempt to repair tank leaks or parts, will void this warranty.

1-YEAR EXCLUSIVE KENMORE LABOR WARRANTY

For the first year from the date of purchase, Sears will, free of charge, supply and install new water heater parts for defective ones or a new water heater for one that develops a leak.

WARRANTY SERVICE

To obtain warranty service, call 1-800-4-MY-HOME® (1-800-469-4663).

This warranty applies only while this product is in use in the United States.

This warranty gives you specific legal rights, and you may have other rights which vary from state to state.

SEARS BRANDS MANAGEMENT CORPORATION, Hoffman Estates, IL 60179

The price of your water heater does not include a free checkup service call. On water heater installations arranged by Sears, Sears warrants the installation.

A charge will be made on service calls due to poor or incomplete installation. These include:

- a. Adjusting thermostat
- b. Condensation
- c. Leaks in pipes or fittings

Master Protection Agreements

Congratulations on making a smart purchase. Your new Kenmore® product is designed and manufactured for years of dependable operation. But like all products, it may require preventive maintenance or repair from time to time. That's when having a Master Protection Agreement can save you money and aggravation.

The Master Protection Agreement also helps extend the life of your new product. Here's what the Agreement* includes:

- **Parts and labor** needed to help keep products operating properly **under normal use**, not just defects. Our coverage goes **well beyond the product warranty**. No deductibles, no functional failure excluded from coverage - **real protection**.
- **Expert service** by a force of more than **10,000 authorized Sears service technicians**, which means someone you can trust will be working on your product.
- **Unlimited service calls and nationwide service**, as often as you want us, whenever you want us.
- **"No-lemon"** guarantee – replacement of your covered product if four or more product failures occur within twelve months.
- **Product replacement** if your covered product can't be fixed.
- **Annual Preventive Maintenance Check** at your request – no extra charge.
- **Fast help by phone** - we call it **Rapid Resolution** - phone support from a Sears representative on all products. Think of us as a "talking owner's manual."
- **Power surge protection** against electrical damage due to power fluctuations.

- **\$250 Food Loss Protection** annually for any food spoilage that is the result of mechanical failure of any covered refrigerator or freezer.
- **Rental reimbursement** if repair of your covered product takes longer than promised.
- **10% discount** off the regular price of any non-covered repair service and related installed parts.

Once you purchase the Agreement, a simple phone call is all that it takes for you to schedule service. You can call anytime day or night, or schedule a service appointment online. The Master Protection Agreement is a risk free purchase. If you cancel for any reason during the product warranty period, we will provide a full refund. Or, a prorated refund anytime after the product warranty period expires. Purchase your Master Protection Agreement today!

Some limitations and exclusions apply. For prices and additional information in the U.S.A. call 1-800-827-6655.

*** Coverage in Canada varies on some items. For full details, call Sears Canada at 1-800-361-6665.**

Sears Installation Service

For Sears professional installation of home appliances, garage door openers, water heaters, and other major home items, in the U.S.A. or Canada call **1-800-4-MY-HOME®**.

INTRODUCTION

Thank You for purchasing this water heater. Properly installed and maintained, it should give you years of trouble free service.

Abbreviations Found In This Instruction Manual:

- CSA - Canadian Standards Association
- ANSI - American National Standards Institute
- NFPA - National Fire Protection Association
- ASME - American Society of Mechanical Engineers
- GAMA - Gas Appliance Manufacturer's Association
- UL - Underwriters Laboratories Inc.

This gas-fired water heater is design certified by CSA International under American National Standard/CSA Standard for Gas Water Heaters ANSI Z21.10.3 • CSA 4.3 (current edition).

PREPARING FOR THE INSTALLATION

1. Read the "General Safety" section, of this manual first and then the entire manual carefully. If you don't follow the safety rules, the water heater will not operate properly. It could cause DEATH, SERIOUS BODILY INJURY AND/OR PROPERTY DAMAGE.

This manual contains instructions for the installation, operation, and maintenance of the gas-fired water heater. You must read and be aware of the warnings placed throughout the manual. All warnings and all instructions are essential to the proper operation of the water heater and your safety. Since we cannot put everything on the first few pages, **READ THE ENTIRE MANUAL BEFORE ATTEMPTING TO INSTALL OR OPERATE THE WATER HEATER.**

2. The installation must conform with these instructions and the local code authority having jurisdiction. In the absence of local codes, the installation must comply with the current editions of the **National Fuel Gas Code, ANSI Z223.1/NFPA 54** and the **National Electrical Code, NFPA 70**. Documents are available from:

Canadian Standards Association,
5060 Spectrum Way,
Mississauga, Ontario, Canada
L4W 5N6

NFPA documents are also available from:
National Fire Protection Association,
1 Batterymarch Park,
Quincy, MA 02269.

3. The water heater when installed must be grounded in accordance with the local codes, or in the absence of local codes: the National Electrical Code (NFPA 70).
4. If after reading this manual you have any questions or do not understand any portion of the instructions, call the local gas utility or the manufacturer whose name appears on the rating plate.

5. Carefully plan the place where you are going to put the water heater. Correct combustion, vent action, and vent pipe installation are very important in preventing death from possible carbon monoxide poisoning and fires (see Figures 1 and 3). Examine the location to ensure the water heater complies with the "Facts to Consider About Location" section in this manual.
6. For California installation this water heater must be braced, anchored, or strapped to avoid falling or moving during an earthquake. See instructions for correct installation procedures. Instructions may be obtained from California Office of the State Architect, 1102 Q Street, Suite 5100, Sacramento, CA 95811.
7. Massachusetts Code requires this water heater to be installed in accordance with Massachusetts 248-CMR 2.00: State Plumbing Code and 248-CMR 5.00, See page 11.
8. Complies with SCAQMD rule #1146 and districts having equivalent NOx requirements.
9. Complies with California's legislation AB1953 and Vermont's legislation Act 193 requirement of a weighted average maximum of 0.25% lead.

GET TO KNOW YOUR WATER HEATER - GAS MODELS

- A Mixing Valve***
- B Hot Water Outlet (Tempered)***
- C Pipe Insulation***
- D Inlet Water Shutoff Valve***
- E Cold Water Inlet***
- F Expansion Tank***
- G Vent Termination Elbow**
- H Access Door (Heat Engine)
- I Earthquake Strap***
- J Power Cord*
- K Main Manual Gas Shutoff Valve***
- L Gas Supply***
- M Sediment Pocket***
- N Condensate Tube
- O Drain Pan***
- P Drain Valve
- Q Heat Engine Hose - Cold In
- R Casing Door (Plastic)
- S Display Enclosure (Plastic)
- T Heat Engine Hose - Hot Out

- U Side Casing (Plastic)
- V Top Casing Enclosure (Plastic)
- W Exhaust Elbow Assembly
- X T&P Relief Valve
- Y Anode
- Z Inlet Dip Tube

* CAUTION HARNESS HAS 120 VAC. IN OPERATION.

** See "Planning the Vent System," "Installation of Vent System" and "Condensate" for more information.

*** These items not included.

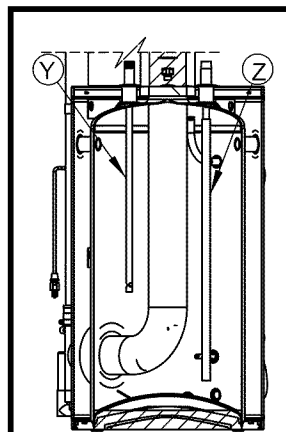
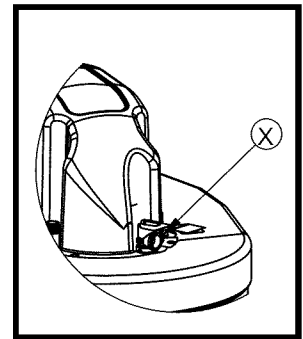
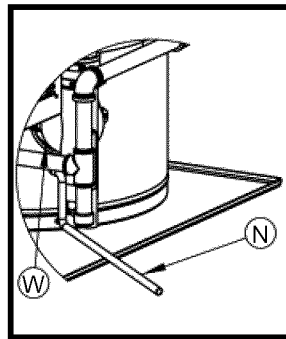
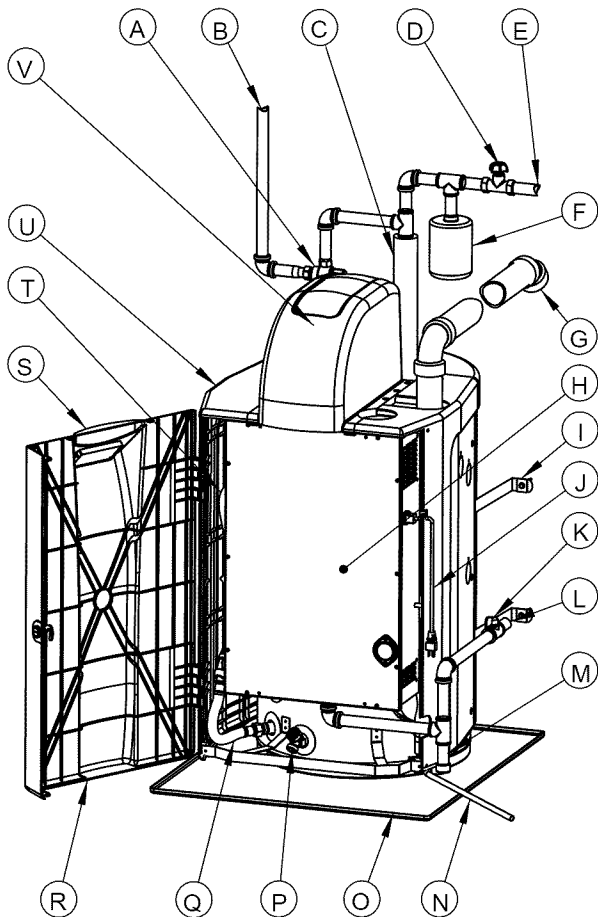


FIGURE 1

INSTALLATION CONSIDERATIONS

ROUGH IN DIMENSIONS

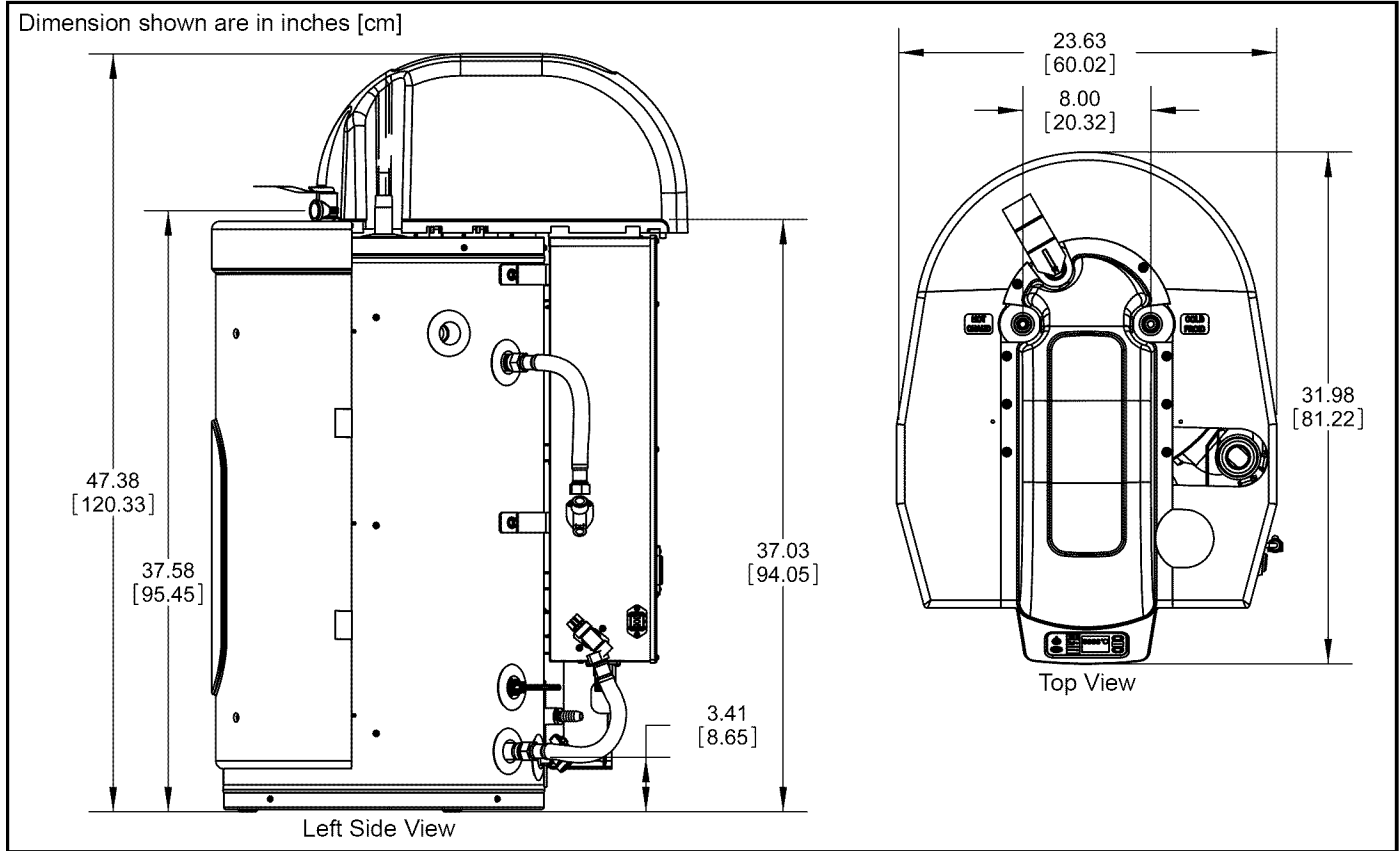


FIGURE 2

Capacity, Gas and Electrical Characteristics

Model	Approx. Capacity		Input BTU/hr	Gas Type	Gas Supply Pressure		Manifold Pressure in. WC (kPa)	Electrical Characteristics	
	U.S. Gals.	Litres			Max. in. WC (kPa)	Min. in. WC (kPa)		Volts/Hz	Amperes
153.331010	25	94.6	100,000	Nat.	14.0 (3.49)	5.0 (1.25)	4.2 (1.05)	120/60	2.5
153.331000 HA	25	94.6	100,000	Nat.	14.0 (3.49)	5.0 (1.25)	4.2 (1.05)	120/60	2.5

Minimum gas supply pressure must be maintained under both load and no load (dynamic and static) conditions.

Manifold Pressure is preset on the gas valve by the manufacturer; **DO NOT ATTEMPT TO ADJUST!**

Thermal efficiency is 90%.

If the hardness of your water supply is more than of 12 grains per gallon (200 mg/L), if your water supply is acidic or otherwise impure, the water supply must be treated with approved methods.

Minimum Clearance To Combustibles						Service Clearance		Test Pressure P.S.I.
Top	Front	Vent	Back	Sides	Floor	Front	Sides	
0	0	0	0	0	0	21" (53.3 cm)	12" (30.5 cm)	300

This appliance must be installed in accordance with local codes or, in the absence of local codes, the "National Fuel Gas Code" ANSI Z223.1/NFPA 54.

Not for installation in a Manufactured Home (Mobile Home).

This water heater is suitable for water (potable) heating only.

This water heater is suitable for installation in a closet or alcove.

INSTALLATION REQUIREMENTS FOR THE COMMONWEALTH OF MASSACHUSETTS

For all side wall terminated, horizontally vented power vent, gas fueled water heaters installed in every dwelling, building or structure used in whole or in part for residential purposes, including those owned or operated by the Commonwealth and where the side wall exhaust vent termination is less than seven (7) feet above finished grade in the area of the venting, including but not limited to decks and porches, the following requirements shall be satisfied:

INSTALLATION OF CARBON MONOXIDE DETECTORS At the time of installation of the side wall horizontal vented gas fueled equipment, the installing plumber or gasfitter shall observe that a hard wired carbon monoxide detector with an alarm and battery back-up is installed on the floor level where the gas equipment is to be installed. In addition, the installing plumber or gasfitter shall observe that a battery operated or hard wired carbon monoxide detector with an alarm is installed on each additional level of the dwelling, building or structure served by the sidewall horizontal vented gas fueled equipment. It shall be the responsibility of the property owner to secure the services of qualified licensed professionals for the installation of hard wired carbon monoxide detectors.

In the event that the side wall horizontally vented gas fueled equipment is installed in a crawl space or an attic, the hard wired carbon monoxide detector with alarm and battery back-up may be installed on the next adjacent floor level.

In the event that the requirements of this subdivision can not be met at the time of completion of installation, the owner shall have a period of thirty (30) days to comply with the above requirements provided that during said thirty (30) day period, a battery operated carbon monoxide detector with an alarm shall be installed.

APPROVED CARBON MONOXIDE DETECTORS Each carbon monoxide detector as required in accordance with the above provisions shall comply with NFPA 720 and be ANSI/UL 2034 listed and CSA certified.

SIGNAGE A metal or plastic identification plate shall be permanently mounted to the exterior of the building at a minimum height of eight (8) feet above grade directly in line with the exhaust vent terminal for the horizontally vented gas fueled heating appliance or equipment. The sign shall read, in print size no less than one-half (1/2) inch in size, **“GAS VENT DIRECTLY BELOW. KEEP CLEAR OF ALL OBSTRUCTIONS.”**

INSPECTION The state or local gas inspector of the side wall horizontally vented gas fueled equipment shall not approve the installation unless, upon inspection, the inspector observes carbon monoxide detectors and signage installed in accordance with the provisions of 248 CMR 5.08(2)(a) 1 through 4.

EXEMPTIONS: The following equipment is exempt from 248 CMR 5.08(2)(a)1 through 4:

1. The equipment listed in Chapter 10 entitled “Equipment Not Required To Be Vented” in the most current edition of NFPA 54 as adopted by the Board; and
2. Product Approved side wall horizontally vented gas fueled equipment installed in a room or structure separate from the dwelling, building, or structure used in whole or in part for residential purposes.

MANUFACTURER REQUIREMENTS - GAS EQUIPMENT VENTING SYSTEM PROVIDED When the manufacturer of Product Approved side wall horizontally vented gas equipment provides a venting system design or venting system components with the equipment, the instructions provided by the manufacturer for installation of the equipment and the venting system shall include:

1. Detailed instructions for the installation of the venting system design or the venting system components; and
2. A complete parts list for the venting system design or venting system.

MANUFACTURER REQUIREMENTS - GAS EQUIPMENT VENTING SYSTEM NOT PROVIDED When the manufacturer of a Product Approved side wall horizontally vented gas fueled equipment does not provide the parts for venting the flue gases, but identifies “special venting systems,” the following requirements shall be satisfied by the manufacturer:

1. The referenced “special venting system” instructions shall be included with the appliance or equipment installation instructions; and
2. The “special venting systems” shall be Product Approved by the Board, and the instructions for that system shall include a parts list and detailed installation instructions.

A copy of all installation instructions for all Product Approved side wall horizontally vented gas fueled equipment, all venting instructions, all parts lists for venting instructions, and/or all venting design instructions shall remain with the appliance or equipment at the completion of the installation.

WATER PIPING - MIXING VALVE USAGE

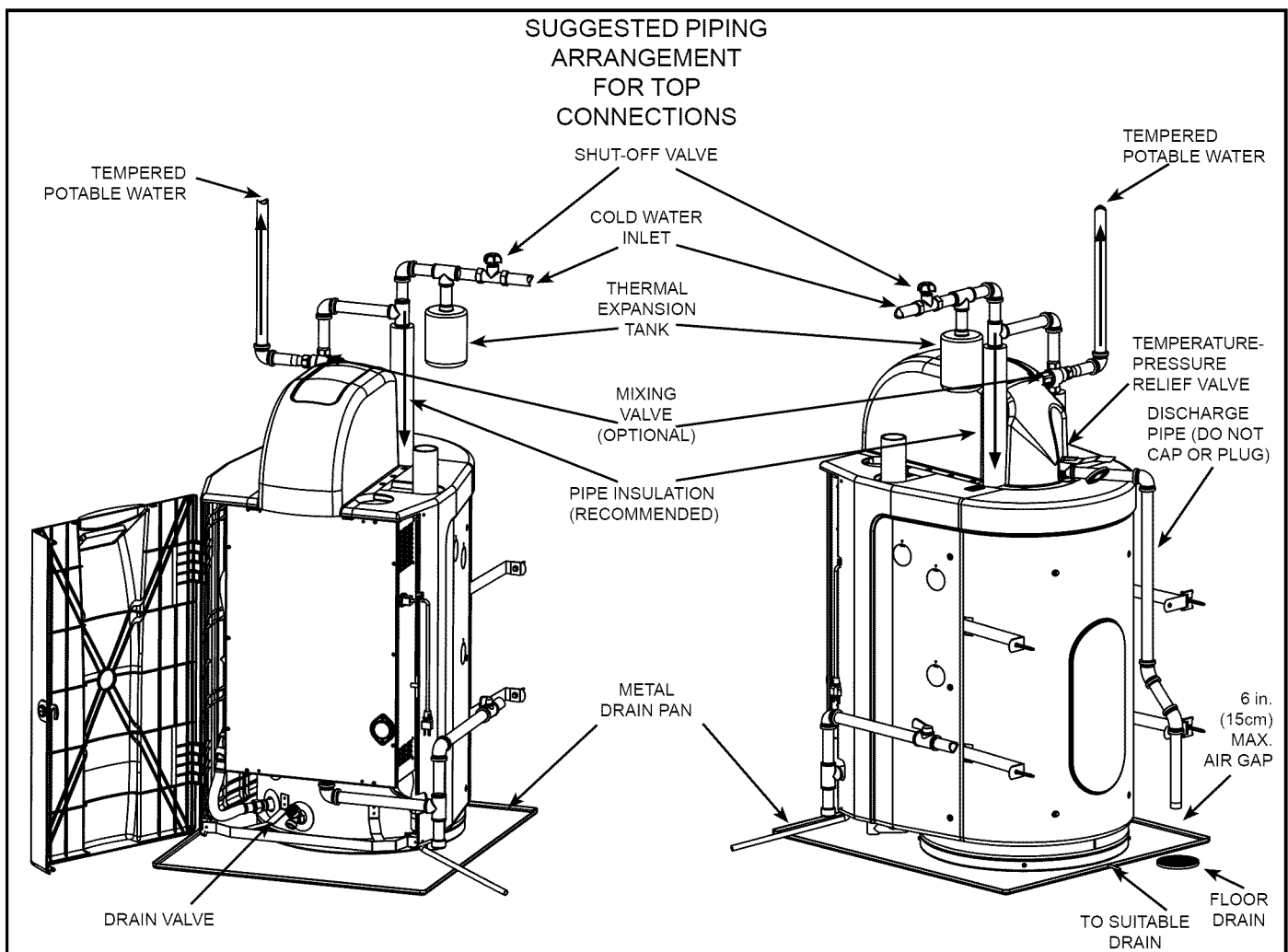


FIGURE 3

This appliance has been design certified as complying with ANSI Z21.10.3/CSA 4.3 (latest revision) for water heaters and is considered suitable for:

Water (Potable) Heating: All models are considered suitable for water (potable) heating.

The Hybrid water heater is a unique design that combines the technology of both the storage tank and tankless type water heaters. A tankless water heater ensures a fixed constant outlet water temperature. This is achieved by modulating the water flow to ensure that this temperature is maintained. In the Hybrid the water supply is heated as it flows through the heat exchanger over the burners similar to the tankless water heaters. The heated water is then stored in the top of the storage tank.

The tank outlet water temperature will be within a maximum of 5°F (2.8°C) of the display set-point when the unit ends the call for heat.

If required by local codes or if a higher fixed temperature is required, a mixing valve can be installed as shown on Figure3.

Please note the following:

The system should be installed only with piping that is suitable for potable (drinkable) water such as copper,

CPVC, PEX or polybutylene. **DO NOT** use PVC water piping.

DO NOT use any pumps, valves, or fittings that are not compatible with potable water.

DO NOT use valves that may cause excessive restriction to water flow. Use full flow ball or gate valves only.

DO NOT use any lead based solder in potable water lines. Use appropriate tin-antimony or other equivalent material.

DO NOT tamper with the gas control/thermostat, igniter or temperature and pressure relief valve. Only qualified service technicians should service these components.

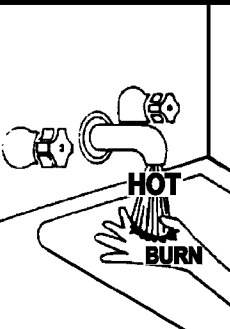
DO NOT use with piping that has been treated with chromates, boiler seal, or other chemicals.

DO NOT add any chemicals to the system piping which will contaminate the potable water supply.

HOT WATER CAN SCALD:

Water heaters are intended to produce hot water. Water heated to a temperature which will satisfy space heating, clothes washing, dish washing, and other sanitizing needs can scald and permanently injure you upon contact. Some people are more likely to be permanently injured by hot water than others. These include the elderly, children, and the physically or developmentally disabled. If anyone

using hot water from this heater fits into one of these groups or if there is a local code or state law requiring a certain temperature water at the hot water tap, then you must take special precautions. In addition to using the lowest possible temperature setting that satisfies your hot water needs, a means such as a Mixing Valve should be used at the hot water taps used by these people or at the water heater (see Figure 3). Mixing valves are available at plumbing supply or hardware stores. Consult a Qualified Installer or Service Agency. Follow the mixing valve manufacturer's instructions for installation of the valves. Before changing the factory setting on the thermostat, read the "Temperature Regulation" section in this manual.

⚠ DANGER	<p>Water temperature over 125°F (52°C) can cause severe burns instantly resulting in severe injury or death.</p> <p>Children, the elderly, and the physically or mentally disabled are at highest risk for scald injury.</p> <p>Feel water before bathing or showering.</p> <p>Temperature limiting valves are available.</p> <p>Read instruction manual for safe temperature setting.</p>
	

FACTS TO CONSIDER ABOUT LOCATION

Carefully choose an indoor location for the new water heater, because the placement is a very important consideration for the safety of the occupants in the building and for the most economical use of the appliance. **This water heater is not for use in manufactured (mobile) homes or outdoor installation.**

Whether replacing an old water heater or putting the water heater in a new location, the following critical points must be observed:

1. Select a location indoors as close as practical to the vent terminal or location to which the water heater vent piping is going to be connected, and as centralized with the water piping system as possible.
2. A pressure-reducing valve and/or an expansion tank may be required for installations where the water pressure is high. The pressure-reducing valve should be located on the supply to the entire house in order to maintain equal hot and cold water pressure.
3. Selected location must provide adequate clearances for servicing and proper operation of the water heater.
4. Avoid locations that could cause the water heater to freeze from outside air.
5. Selected location must provide access to a properly grounded electrical branch circuit. A dedicated circuit is preferred. Do not use a GFI outlet.

Important: Do not use an extension cord to connect the water heater to an electrical outlet.

Important: The electrical controls used inside the gas

control of this water heater are polarity sensitive. Ensure the electrical supply is connected correctly in the receptacle box. Failure to connect correctly will prevent the unit from functioning properly.

CAUTION
Property Damage Hazard
<ul style="list-style-type: none"> • All water heaters eventually leak. • Do not install without adequate drainage.

Installation of the water heater must be accomplished in such a manner that if the tank or any connections should leak, the flow will not cause damage to the structure. For this reason, it is not advisable to install the water heater in an attic or upper floor. When such locations cannot be avoided, a suitable metal drain pan should be installed under the water heater. Drain pans are available at your local hardware store. Such a drain pan must have a clearance of at least 1.0 in. (2.5cm) greater than any point on the water heater's outer jacket and must be piped to an adequate drain. The pan must not restrict combustion air flow. See Figure 1.

Water heater life depends upon water quality, water pressure and the environment in which the water heater is installed. Water heaters are sometimes installed in locations where leakage may result in property damage, even with the use of a drain pan piped to a drain. However, unanticipated damage can be reduced or prevented by a leak detector or water shut-off device used in conjunction with a piped drain pan. These devices are highly recommended and are available from some plumbing supply wholesalers and retailers, and detect and react to leakage in various ways:

- Sensors mounted in the drain pan that trigger an alarm or turn off the incoming water to the water heater when leakage is detected.
- Sensors mounted in the drain pan that turn off the water supply to the entire building when water is detected in the drain pan.
- Water supply shut-off devices that activate based on the water pressure differential between the cold water and hot water pipes connected to the water heater.
- Devices that will turn off the gas supply to a gas water heater while at the same time shutting off its water supply.

AVOID AREAS WHERE FLAMMABLE LIQUIDS (VAPORS) ARE LIKELY TO BE PRESENT OR STORED (GARAGES, STORAGE AND UTILITY AREAS, ETC.): Flammable liquids (such as gasoline, solvents, propane (LP or butane, etc.) and other substances (such as adhesives, etc.)) emit flammable vapors which can be ignited by a gas water heater's igniter or main burner. The resulting flashback and fire can cause death or serious burns to anyone in the area.

Also, the water heater must be located and/or protected so

it is not subject to physical damage by a moving vehicle.

! WARNING

Fire or Explosion Hazard

- Do not store or use gasoline or other flammable vapors and liquids in the vicinity of this or any other appliance.
- Avoid all ignition sources if you smell gas.
- Do not expose water heater control to excessive gas pressure.
- Use only gas shown on rating plate.
- Maintain required clearances to combustibles.
- Keep ignition sources away from faucets after extended period of non-use.

Read instruction manual before installing, using or servicing water heater.

HANDLE INSTALLATION

For ease of handling and carrying, plugs are provided in the side of the shroud that can be removed and pipe handles inserted (see Figure 4).

- Remove plastic plugs from shroud side panels.
- Screw a short length of 3/4" NPT pipe into the sides of the water heater.
- Use the handles to move the water heater to the desired location.
- Remove the handles.
- Reinstall the plastic plugs in the shroud side panels.

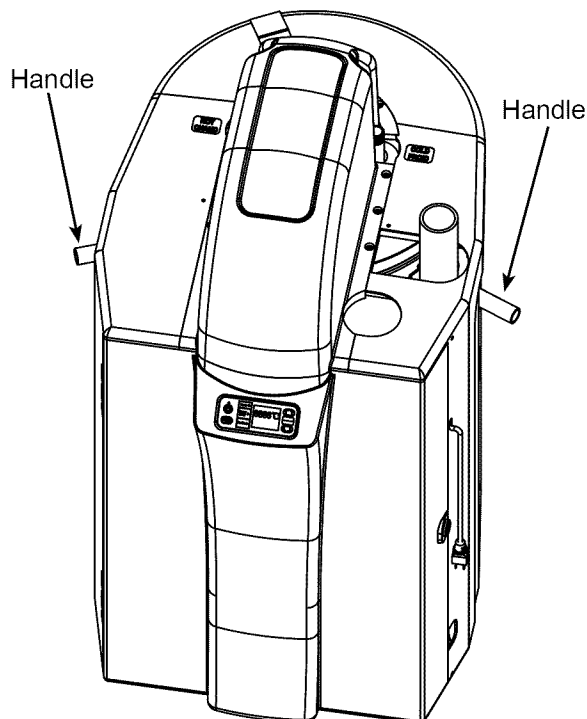


FIGURE 4

! DANGER

! Vapors from flammable liquids may explode and catch fire causing death or severe burns.

Do not use or store flammable products such as gasoline, solvents or adhesives in the same room or area near the water heater.

Keep flammable products:

1. far away from heater,
2. in approved containers,
3. tightly closed and
4. out of children's reach.

Water heater has a main burner and spark generator. The spark generator:

1. can be triggered at any time and
2. the spark will ignite flammable vapors.

Vapors:

1. cannot be seen,
2. are heavier than air,
3. go a long way on the floor and
4. can be carried from other rooms to the the electrodes by air currents.

Installation: Do not install the water heater where flammable products will be stored or used.

! WARNING

Fire Hazard

For continued protection against risk of fire:

- Do not install water heater on carpeted floor.
- Do not operate water heater if flood damaged.

This water heater must not be installed directly on carpeting. Carpeting must be protected by metal or wood panel beneath the appliance extending beyond the full width and depth of the appliance by at least 3in. (7.6cm) in any direction, or if the appliance is installed in an alcove or closet, the entire floor must be covered by the panel. Failure to heed this warning may result in a fire hazard.

! WARNING

Fire or Explosion Hazard

Read instruction manual before installing, using or servicing water heater.

- Improper use may result in fire or explosion.
- Maintain required clearances to combustibles.

When installing the heater, consideration must be given to proper location. Location selected should be as close to the wall as practicable and as centralized with the water piping system as possible.

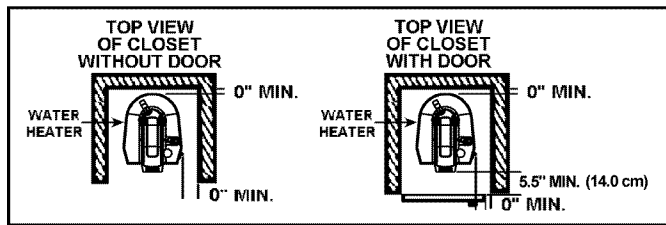


FIGURE 5

Minimum clearances between the water heater and combustible construction are 0 in. at the sides and rear, 0 in. (0cm) from the front and 2 in. (5.08cm) from the top (see Figure 5). If clearances stated on the heater differ from these distances, install water heater according to clearances stated on the heater.

Adequate top clearance of 24 in. (61cm) for servicing this appliance, such as changing the anodes etc., should be considered before installation.

A minimum front clearance of 20 in. (51cm) and 10 in. (26cm) of side clearance must be allowed for access to replaceable parts.

EARTHQUAKE ZONES

In Earthquake Zones the water heater must be braced, anchored, or strapped to avoid moving during an earthquake. Contact local utilities for code requirements in your area. Follow the manufacturer's instructions for installing the braces. Be sure to wear protective goggles and gloves when handling any kind of sheet metal product.

Tabs have been provided on each side of the rear portion of the shroud. The top and bottom of each tab must be cut and gently bent "inwards" thus allowing the straps to exit the shroud (see Figure 9).

In order to access the tabs and install the earthquake straps it is necessary to remove the top, front and side panels of the shroud as follows (see Figures 6 - 8):

Door opening

1. Unlock the door by rotating the lock counter-clockwise with a wide, slot screwdriver.
2. Release the top and bottom door pins by prying the pins out, using a small screwdriver.
3. Open the door (the door remains fastened to the left side panel).

Remove the top casing (front).

1. Use a screwdriver to remove the six screws securing the top casing.
2. Lift up and remove casing top (front).

Remove the right side panel

1. Use a screwdriver to remove the screw from the bottom, front of the right side panel.
2. Remove the three screws from the right side panel towards the rear of the unit.
3. Remove the screw from the top of the unit.
4. Push the panel back and lift out.

Remove the left side panel

1. Use a screwdriver to remove the screw from the bottom, front of the left side panel.
2. Remove the three screws from the left side panel towards the rear of the unit.
3. Remove the screw from the top of the unit.
4. Push the panel back and lift out.

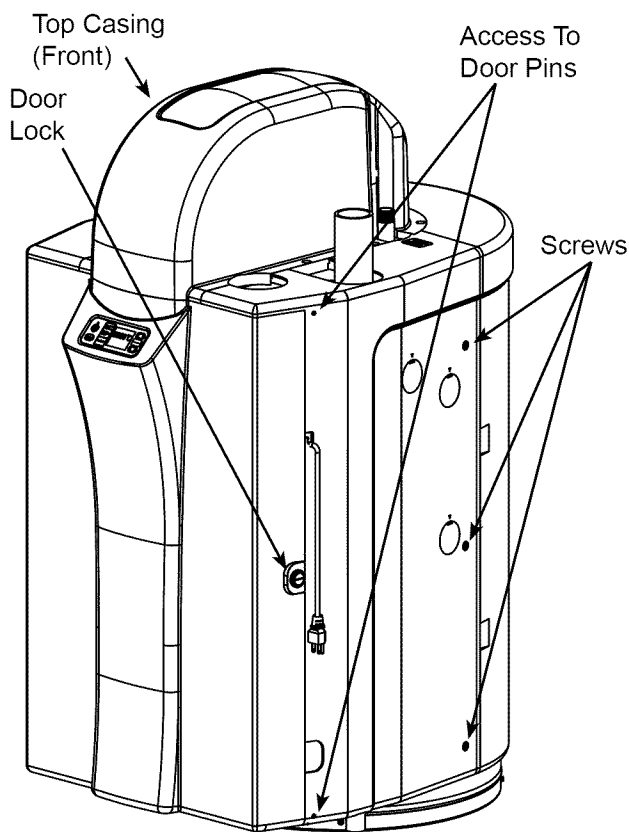


FIGURE 6

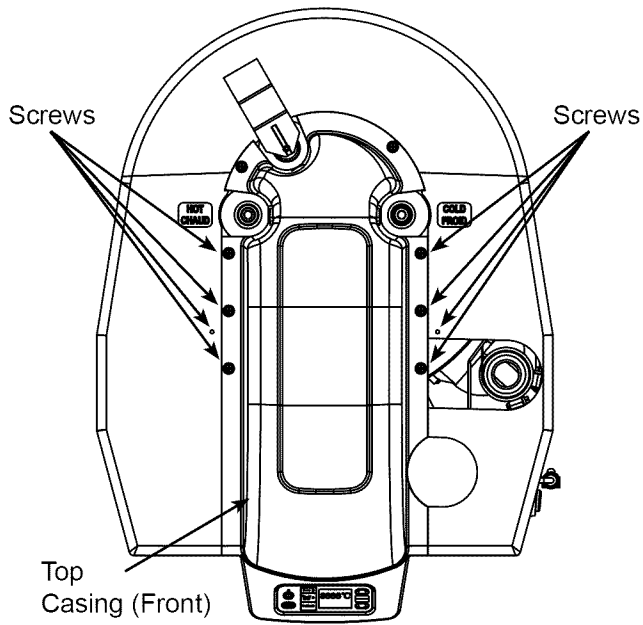


FIGURE 7

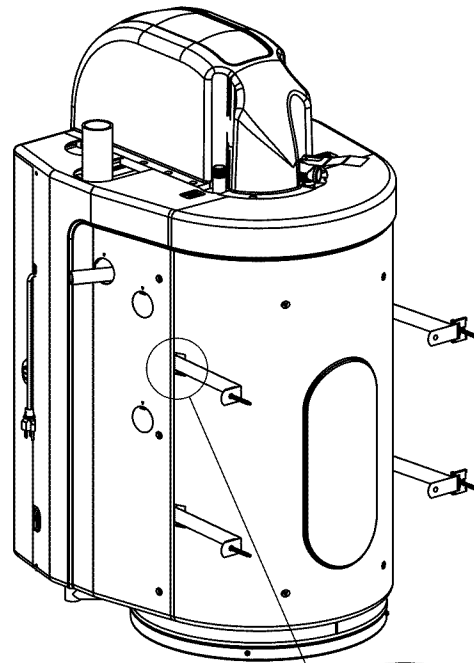


FIGURE 9

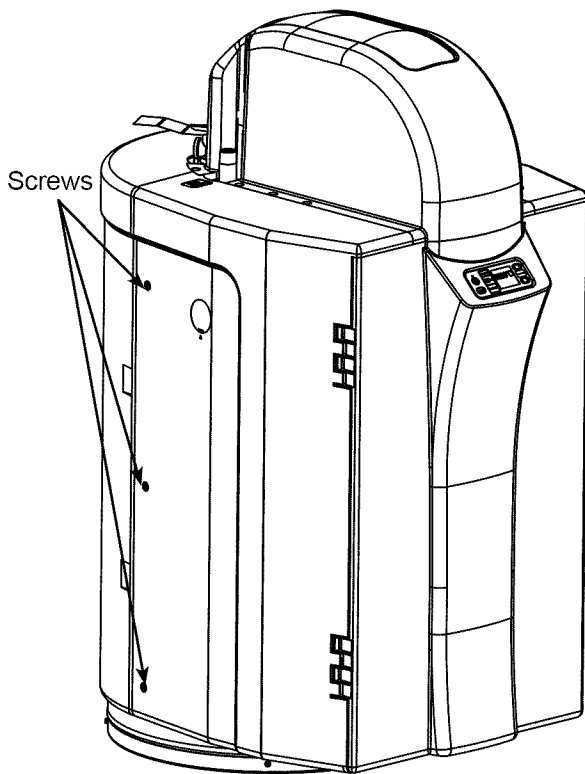


FIGURE 8

After the heater has been positioned and the earthquake straps have been installed, re-assemble the shroud in the reverse order.

COMBUSTION AIR AND VENTILATION

A gas water heater cannot operate properly without the correct amount of air for combustion. Do not install in a confined area such as a closet, unless you provide air as shown in the “Facts to Consider About Location” section. Never obstruct the flow of ventilation air. If you have any doubts or questions at all, call your gas supplier. Failure to provide the proper amount of combustion air can result in a fire or explosion and cause death, serious bodily injury, or property damage.

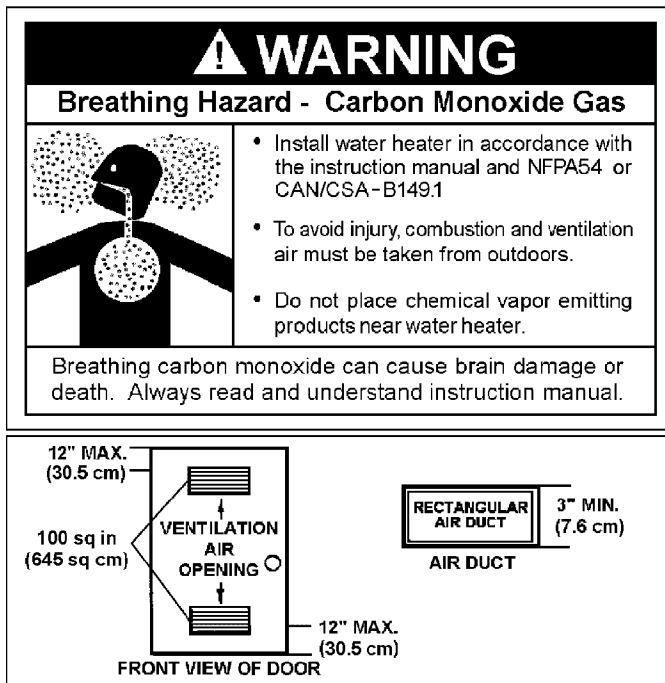


FIGURE 10

If this water heater will be used in beauty shops, barber shops, cleaning establishments, or self-service laundries with dry cleaning equipment, it is imperative that the water heater(s) be installed so that all air for combustion and ventilation is taken from outdoors.

Note: Vent length should be long enough that the outside air will not freeze the water heater.

Propellants of aerosol sprays and volatile compounds, (cleaners, chlorine based chemicals, refrigerants, etc.) in addition to being highly flammable in many cases, will also react to form corrosive hydrochloric acid when exposed to the combustion products of the water heater. The results can be hazardous, and also cause product failure.

APPLIANCES IN UNCONFINED SPACES

UNCONFINED SPACE is space whose volume is not less than 50 cubic feet per 1,000 Btu per hour (4.8 cubic meters per kW) of the aggregate input rating of all appliances installed in that space. Rooms communicating directly with the space in which the appliances are installed, through openings not furnished with doors, are considered a part of the unconfined space.

In unconfined spaces in buildings, infiltration may be adequate to provide air for combustion, ventilation and dilution of flue gases. However, in buildings of tight construction (for example, weather stripping, heavily insulated, caulked, vapor barrier, etc.), additional air may need to be provided using the methods described in “Appliances in Confined Space” that follows.”

APPLIANCES IN CONFINED SPACES

CONFINED SPACE is a space whose volume is less than 50 cubic feet per 1,000 Btu per hour (4.8m³ per kW) of the aggregate input rating of all appliances installed in that space.

When drawing combustion air from inside a building to a confined space, such a space should be provided with two permanent openings. ONE WITHIN 12 in. (30cm) OF THE ENCLOSURE TOP AND ONE WITHIN 12 in. (30cm) OF THE ENCLOSURE BOTTOM. Each opening should have a free area of 1 square inch per 1000 Btu/hr (22 cm²/kW) of the total input of all appliances in the enclosure, but not less than 100 square in. (645 cm²).

If the confined space is within a building, air for combustion and ventilation must be obtained from outdoors. When directly communicating with the outdoors or communicating through vertical ducts, two permanent openings, located in the above manner, should be provided. Each opening should have a free area of not less than 1 square inch per 4000 Btu/hr (5.5 cm²/kW) of total input of all appliances in the enclosure. If horizontal ducts are used, each opening should have a free area of not less than 1 square inch per 2000 Btu/hr (11 cm²/kW) of the total input of all appliances in the enclosure.

A. ALL AIR FROM INSIDE BUILDINGS: (See Figures 10 & 11)

The confined space should be provided with two permanent openings communicating directly with an additional room(s) of sufficient volume so that the combined volume of all spaces meets the criteria for an unconfined space. The total input of all gas utilization equipment installed in the combined space should be considered in making this determination. Each opening should have a minimum free area of 1 square inch per 1,000 Btu per hour (22 cm²/kW) of the total input rating of all gas utilization equipment in the confined space, but not less than 100 square in. (645 cm²). One opening should commence within 12 in. (30cm) of the top and one commencing within 12 in. (30cm) of the bottom of the enclosures.

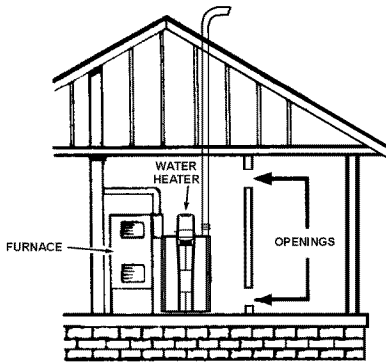


FIGURE 11

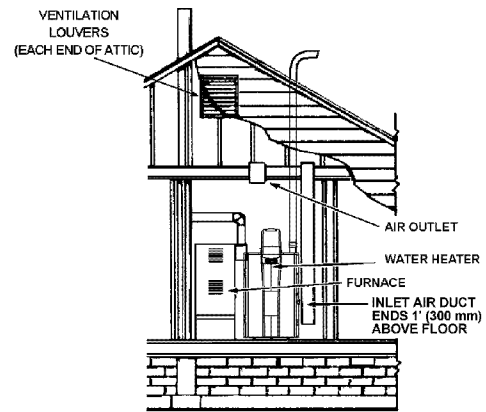


FIGURE 13

B. ALL AIR FROM OUTDOORS: (See Figures 12, 13 and 14)

The confined space should be provided with two permanent openings, one commencing within 12 in. (30cm) of the top and one commencing within 12 in. (30cm) from the bottom of the enclosure. The openings should communicate directly, or by ducts, with the outdoors or spaces (crawl or attic) that freely communicate with the outdoors.

1. When directly communicating with the outdoors, each opening should have a minimum free area of 1 square inch per 4,000 Btu per hour (5.5 cm²/kW) of total input rating of all equipment in the enclosure (see Figure 12).

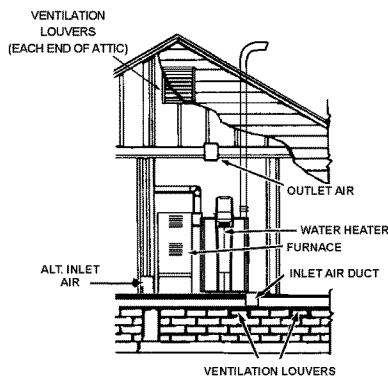


FIGURE 12

4. When ducts are used, they should be of the same cross-sectional area as the free area of the openings to which they connect. The minimum short side dimension of rectangular air ducts should not be less than 3 in. (7.6cm) (see Figure 14).

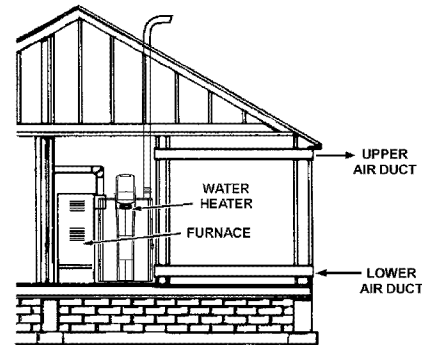


FIGURE 14

5. Alternatively a single permanent opening may be used when communicating directly with the outdoors, or with spaces that freely communicate with the outdoors. The opening should have a minimum free area of 1 square inch per 3,000 BTU per hour (7.3 cm²/kW) of total input rating of all equipment in enclosure (see Figure 15).

2. When communicating with the outdoors through vertical ducts, each opening should have a minimum free area of 1 square inch per 4,000 Btu per hour (5.5 cm²/kW) of total input rating of all equipment in the enclosure (see Figure 13).
3. When communicating with the outdoors through horizontal ducts, each opening should have a minimum free area of 1 square inch per 2,000 Btu per hour (11 cm²/kW) of total input rating of all equipment in the enclosure (see Figure 14).

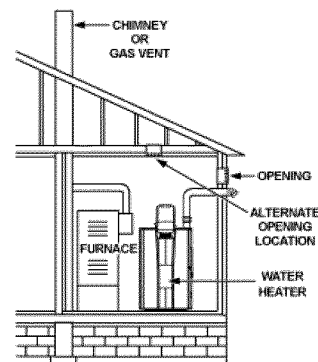


FIGURE 15

6. Louvers and Grilles: In calculating free area, consideration should be given to the blocking effect of louvers, grilles or screens protecting openings. Screens used should not be smaller than 1/4 in. (0.64cm) mesh. If the free area through a design of louver or grille is known, it should be used in calculating the size opening required to provide the free area specified. If the design and free area is not known, it may be assumed that wood louvers will be 20-25 percent free area and metal louvers and grilles will have 60-75 percent free area. Louvers and grilles should be fixed in the open position or interlocked with the equipment so that they are opened automatically during equipment operation.

7. Special Conditions Created by Mechanical Exhausting or Fireplaces: operation of exhaust fans, ventilation systems, clothes dryers or fireplaces may create conditions requiring special attention to avoid unsatisfactory operation of installed gas utilization equipment.

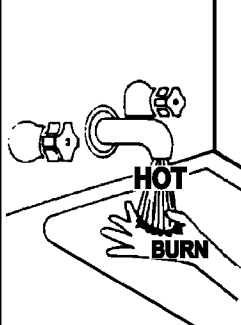
CHEMICAL VAPOR CORROSION

CORROSION OF THE FLUEWAYS AND VENT SYSTEM MAY OCCUR IF AIR FOR COMBUSTION CONTAINS CERTAIN CHEMICAL VAPORS. SUCH CORROSION MAY RESULT IN FAILURE AND RISK OF ASPHYXIATION.

Spray can propellants, cleaning solvents, refrigerator and air conditioning refrigerants, swimming pool chemicals, calcium and sodium chloride (water softener salt), waxes, and process chemicals are typical compounds which are potentially corrosive.

Do not store products of this sort near the heater. Also, air which is brought in contact with the heater should not contain any of these chemicals. If necessary, uncontaminated air should be obtained from remote or outside sources.

WATER PIPING

	<p>! DANGER Water temperature over 125°F (52°C) can cause severe burns instantly resulting in severe injury or death.</p> <p>Children, the elderly, and the physically or mentally disabled are at highest risk for scald injury.</p> <p>Feel water before bathing or showering.</p> <p>Temperature limiting valves are available.</p> <p>Read instruction manual for safe temperature setting.</p>
---	--

HOT WATER CAN SCALD:

Water heaters are intended to produce hot water. Water heated to a temperature which will satisfy space heating, clothes washing, dish washing, cleaning and other sanitizing needs can scald and permanently injure you upon contact. Some people are more likely to be permanently injured by hot water than others. These include the elderly, children, the physically or developmentally disabled. If anyone using hot water fits into one of these groups or if there is a local code or state law requiring a certain temperature water at the hot water tap, then you must take special precautions. In addition to using the lowest possible temperature setting that satisfies your hot water needs, a means such as a mixing valve, should be used at the hot water taps used by these people or at the water heater (see Figure 3). Valves for reducing point of use temperature by mixing cold and hot water are also available:

Consult a Qualified Installer or Service Agency. Follow manufacturer's instructions for installation of the valves. Before changing the factory setting on the thermostat, read the "Temperature Regulation" section in this manual.

<p>! WARNING</p> <p>Toxic Chemical Hazard</p> <p>• Do not connect to non-potable water system.</p>
--

This water heater should not be connected to any heating systems or component(s) used with a non-potable water heating appliance.

All piping components connected to this unit should be suitable for use with potable water.

Toxic chemicals, such as those used for boiler treatment should not be introduced into this system.

When the system requires water for space heating at temperatures higher than required for domestic water purposes, a mixing valve must be installed. Please refer to Figure 3 for suggested piping arrangement.

CLOSED WATER SYSTEMS

Water supply systems may, because of code requirements or such conditions as high line pressure, among others, have installed devices such as pressure reducing valves, check valves, and back flow preventers. Devices such as these cause the water system to be a closed system.

THERMAL EXPANSION

As water is heated, it expands (thermal expansion). In a closed system, the volume of water will increase. As the volume of water increases, there will be a corresponding increase in water pressure due to thermal expansion. Thermal expansion can cause premature tank failure

(leakage). This type of failure is not covered under the limited warranty. Thermal expansion can also cause intermittent temperature-pressure relief valve operation: water discharged from the valve due to excessive pressure build up. The temperature-pressure relief valve is not intended for the constant relief of thermal expansion. This condition is not covered under the limited warranty.

A properly-sized thermal expansion tank should be installed on all closed systems to control the harmful effects of thermal expansion. Contact a plumbing service agency or your retail supplier regarding the installation of a thermal expansion tank.

CAUTION
Property Damage Hazard
<p>Avoid water heater damage:</p> <ul style="list-style-type: none"> • Install thermal expansion tank if necessary. • Do not apply heat to water fittings. • Contact qualified installer or service agency.

NOTE: If using copper tubing, solder tubing to an adapter before attaching the adapter to the water heater connections. Do not solder the water lines directly to the water heater connections. It will harm the dip tube and damage the tank.

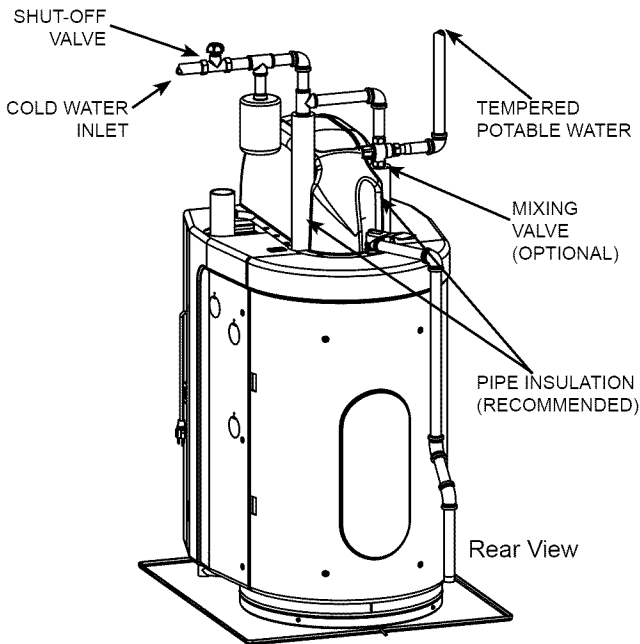


FIGURE 16

NOTE: To protect against untimely corrosion of hot and cold water fittings, it is strongly recommended that di-electric unions or couplings be installed on this water heater when connected to copper pipe (see Figure 3 also).

Figures 3 and 16 show the typical attachment of the water piping to the water heater. The water heater is equipped with 3/4" NPT water connections.

HARD WATER

We highly recommend installing water filtering system or a water softener before the water heater system. If you are installing a water filtering system use a 5 micron filter to reduce particles that can potentially cause nuisance shutdown problems and prolong the maintenance of the water heater's inlet filter. A water softener can affect the life of the anode installed in this water heater. Refer to "Anode Rod Inspection" section in this manual.

Clean the filter on the water inlet as frequently as required by the quality of your local water. Refer to "Cleaning The Inlet Water Filter" section of this manual. One additional filter is supplied with your water heater.

TEMPERATURE-PRESSURE RELIEF VALVE

	WARNING
	Explosion Hazard
	<ul style="list-style-type: none"> • Temperature-pressure relief valve must comply with ANSI Z21.22- CSA 4.4 and ASME code. • Properly sized temperature-relief valve must be installed in opening provided. • Can result in overheating and excessive tank pressure. • Can cause serious injury or death.

This heater is provided with a properly certified combination temperature - pressure relief valve by the manufacturer.

The valve is certified by a nationally recognized testing laboratory that maintains periodic inspection of production of listed equipment of materials as meeting the requirements for Relief Valves for Hot Water Supply Systems, ANSI Z21.22 • CSA 4.4, and the code requirements of ASME.

If replaced, the valve must meet the requirements of local codes, but not less than a combination temperature and pressure relief valve certified as indicated in the above paragraph.

The valve must be marked with a maximum set pressure not to exceed the marked hydrostatic working pressure of the water heater (150 psi = 1,035 kPa) and a discharge capacity not less than the water heater Btu/hr input rate as shown on the water heater's rating plate.

For safe operation of the water heater, the relief valve must not be removed from its designated opening nor plugged.

The temperature-pressure relief valve must be installed directly into the fitting of the water heater designed for the relief valve. Must terminate a maximum of 6 in. (15cm) above a floor drain or external to the building. In cold climates, it is recommended that the discharge pipe be terminated at an adequate drain inside the building. Be certain that no contact is made with any live electrical part. The discharge opening must not be blocked or reduced in size under any circumstances. Excessive length, over 30 ft. (9.14m), or use of more than four elbows can cause restriction and reduce the discharge capacity of the valve (see Figure 3).

No valve or other obstruction is to be placed between the relief valve and the tank. Do not connect tubing directly to discharge drain unless a 6 in. (15cm) air gap is provided. To prevent bodily injury, hazard to life, or property damage, the relief valve must be allowed to discharge water in quantities should circumstances demand. If the discharge pipe is not connected to a drain or other suitable means, the water flow may cause property damage.

The temperature-pressure relief valve must be manually operated at least once a year, (see Figure 17). Caution should be taken to ensure that (1) no one is in front of or around the outlet of the temperature-pressure relief valve discharge line, and (2) the water manually discharged will not cause any bodily injury or property damage because the water may be extremely hot.

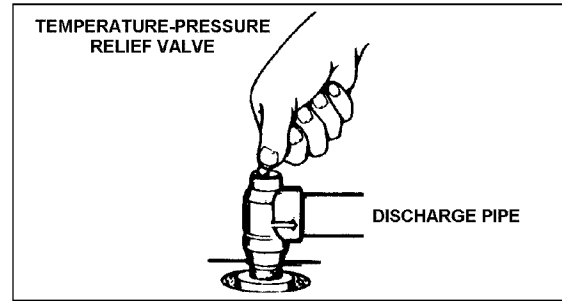


FIGURE 17

If after manually operating the valve, it fails to completely reset and continues to release water, immediately close the cold water inlet to the water heater, follow the draining instructions, and replace the temperature-pressure relief valve with a new one.

T&P Valve and Pipe Insulation (if supplied)

Remove insulation for T&P valve and pipe connections from carton.

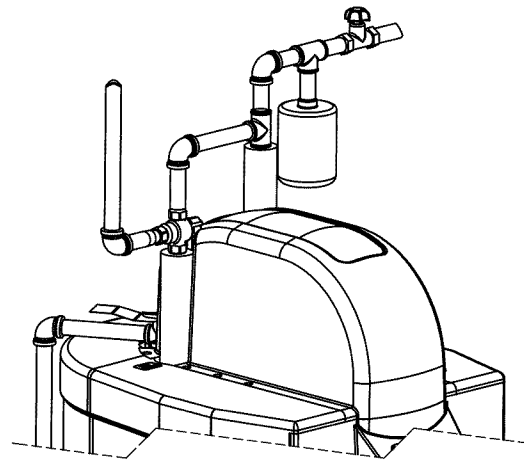


FIGURE 18

Fit pipe insulation over the incoming cold water line and the hot water line. Make sure that the insulation is against the top cover of the heater. Fit T&P valve insulation over valve. Make sure that the insulation does not interfere with the lever of the T&P valve.

Secure all insulation using tape.

CAUTION
Water Damage Hazard
<ul style="list-style-type: none"> • Temperature-pressure relief valve discharge pipe must terminate at adequate drain.

The Discharge Pipe:

- Shall not be smaller in size than the outlet pipe size of the valve, or have any reducing couplings or other restrictions.
- Shall not be plugged or blocked.
- Shall be of material listed for hot water distribution.
- Shall be installed so as to allow complete drainage of both the temperature-pressure relief valve, and the discharge pipe.
- Shall terminate a maximum of 6 in. (15cm) above a floor drain or external to the building. In cold climates, it is recommended that the discharge line be terminated at an adequate drain inside the building.
- Shall not have any valve between the relief valve and tank.

⚠ DANGER	<p>Water temperature over 125°F (52°C) can cause severe burns instantly resulting in severe injury or death.</p> <p>Children, the elderly, and the physically or mentally disabled are at highest risk for scald injury.</p> <p>Feel water before bathing or showering.</p> <p>Temperature limiting valves are available.</p> <p>Read instruction manual for safe temperature setting.</p>

GAS PIPING



Make sure gas supplied is same type listed on model rating plate. The inlet gas pressure must not exceed 14 in. WC (3.5 kPa) for natural and propane gas (L.P.). The minimum inlet gas pressure shown on rating plate is that which will permit firing at rated input.

All gas piping must comply with local codes and ordinances or with the National Fuel Gas Code (ANSI Z223.1/ NFPA-54). Copper or brass tubing and fittings (except tin lined copper tubing) should not be used.

If the gas control valve is subjected to pressures exceeding 1/2 psi (3.5 kPa), the damage to the gas control valve could result in a fire or explosion from leaking gas.

If the main gas line shut-off serving all gas appliances is used, also turn "off" the gas at each appliance. Leave all gas appliances shut "off" until the water heater installation is complete.

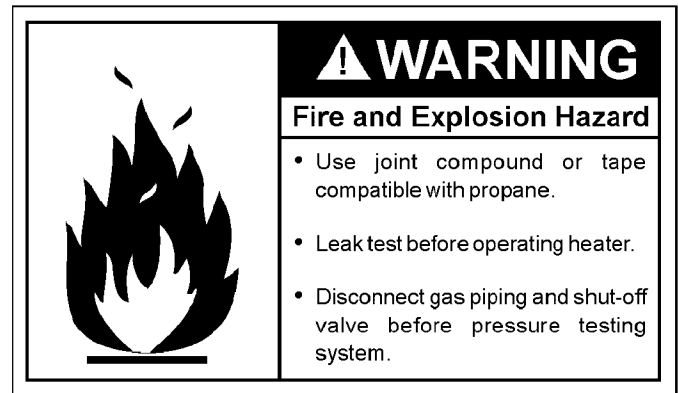
A gas line of sufficient size must be run to the water heater. Consult the current edition of National Fuel Gas Code (ANSI Z223.1/NFPA 54) and your gas supplier concerning pipe size.

There must be:

- A readily accessible manual shut off valve in the gas supply line serving the water heater, and
- A drip leg (sediment trap) ahead of the gas control valve to help prevent dirt and foreign materials from entering the gas control valve.
- A ground joint union or equivalent between the shut off valve and control valve to permit servicing of the unit.

The appliance and its gas connections must be leak tested before placing the appliance in operation. Use a leak test solution, not a match or open flame.

NOTE: An alternate location for the gas line entry is possible. Drill a suitable hole centered on the crosshairs on the left side panel.



Use pipe joint compound or Teflon tape marked as being resistant to the action of petroleum [Propane (L.P.)] gases.

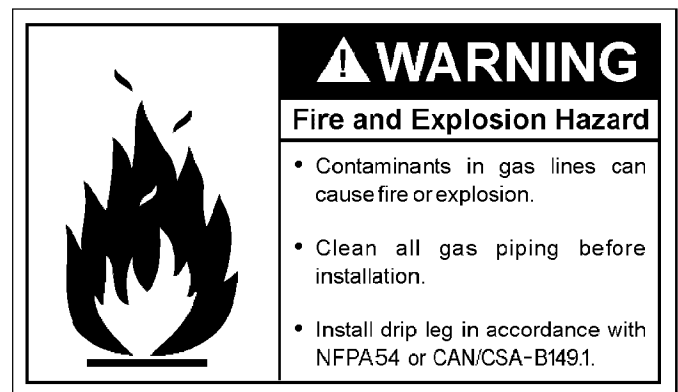
The appliance and its gas connection must be leak tested before placing the appliance in operation.

The appliance and its individual shut-off valve must be disconnected from the gas supply piping system during any pressure testing of the system at test pressures in excess of 1/2 psi (3.5 kPa).

It shall be isolated from the gas supply piping system by closing its individual manual shut-off valve during the pressure testing, the gas supply piping system at test pressures equal to or less than 1/2 psi (3.5 kPa) is considered isolated.

IMPORTANT: MAKE SURE THE GAS LINE IS PIPED WITH HARD PIPE. AVOID FLEX LINE CONSTRUCTION FOR GAS DUE TO POSSIBLE GAS FLOW PROBLEMS.

SEDIMENT TRAPS



A sediment trap shall be installed as close to the gas inlet of the water heater as practical at the time of water heater installation. The sediment trap shall be either a tee fitting with a capped nipple in the bottom outlet or other device recognized as an effective sediment trap.

Contaminants in the gas lines may cause improper operation of the gas control valve that may result in fire or explosion. Before attaching the gas line be sure that all gas pipe is clean on the inside. To trap any dirt or foreign material in the gas supply line, a drip leg (sometimes called

a sediment trap) must be incorporated in the piping. The drip leg must be readily accessible. Install in accordance with the "Gas Piping" section. Refer to the current edition of the National Fuel Gas Code (ANSI Z223.1/NFPA 54).

GAS LINE PURGING

Air may be present in the gas lines and could prevent the burner from lighting on initial start-up. The gas lines should be purged of air by a qualified service technician after installation of the gas piping system.

HIGH ALTITUDE INSTALLATIONS

WARNING

Breathing Hazard - Carbon Monoxide Gas

- Special consideration must be taken with installations above 3,500 ft. (1,067m).
- Please contact a qualified service agent to obtain proper setup and instructions before lighting.
- Failure to implement the proper setup will result in improper and inefficient operation of the appliance resulting in production of increased levels of carbon monoxide gas in excess of the safe limits which could result in serious personal injury or death.

Breathing carbon monoxide can cause brain damage or death. Always read and understand instruction manual.

Standard model is set at the factory to operate at altitudes from sea level to 3,500 feet (1,067m) only. High altitude model is set at the factory to operate at altitudes from 3,501 feet (1,067m) to 6,500 feet (1,981m) above sea level only.

Accessory kits are available to allow the heaters to operate at altitudes higher than 6,500 feet (1,981m). These accessory kits are listed in the table below. Instructions for installing these accessories are include in the kits.

Altitude ft (m)	Kit #
6,501 - 8,500 (1,981 - 2,591)	9007440005
8,501 - 11,000 (2,591 - 3,352)	9007441005

WARNING: THESE HIGH EFFICIENCY WATER HEATERS ARE CERTIFIED FOR USE AT SPECIFIC ALTITUDE RANGES. FOR USE AT ALTITUDES OVER 3,500 FEET (1,067M) OR 6,500 FEET (1,981M) THE PRIMARY CONTROL BOARD (PCB) MUST BE CHANGED. USE THE APPROPRIATE ACCESSORY KIT NUMBER FOR ALTITUDES SHOWN IN THE ABOVE CHART.

FLOODING/FREEZING

If this water heater has been exposed to flooding, freezing, fire or any unusual condition, do not put it into operation until it has been inspected and approved by a qualified service technician. These conditions can result in unseen internal damage and are not subject to warranty coverage.

FILLING THE WATER HEATER

CAUTION

Property Damage Hazard

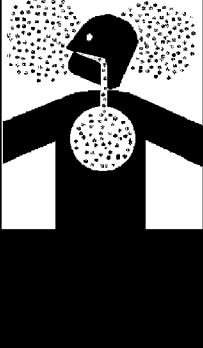
- Avoid water heater damage.
- Fill tank with water before operating.

Never use this water heater unless it is completely full of water. To prevent damage to the tank, the tank must be filled with water. Open the nearest hot water faucet to allow air to escape. Water must flow from the hot water faucet before turning "ON" gas to the water heater.

To fill the water heater with water:

1. Close the water heater drain valve by turning the handle to the right (clockwise). The drain valve is on the lower front of the water heater.
2. Open the cold water supply valve to the water heater tank. **NOTE: The cold water supply valve must be left open when the water heater is in use.**
3. To insure complete filling of the tank, allow air to exit by opening the nearest hot water faucet. Allow water to run until a constant flow is obtained. This will let air out of the water heater and the piping.
4. Check all water piping and connections for leaks. Repair as needed.

VENTING

⚠ WARNING	
Breathing Hazard - Carbon Monoxide Gas	
	<ul style="list-style-type: none"> • Install vent system in accordance with codes. • Do not operate water heater if flood damaged. • Install water heater in accordance with the instruction manual. • Do not operate if soot buildup. • Do not obstruct water heater air intake with insulating jacket. • Do not place chemical vapor emitting products near water heater. • Gas and carbon monoxide detectors are available. • Never operate the heater unless it is vented to the outdoors and has adequate air supply to avoid risks of improper operation, fire, explosion or asphyxiation. • Analyze the entire vent system to make sure that condensate will not become trapped in a section of vent pipe and therefore reduce the open cross sectional area of the vent.
<p>Breathing carbon monoxide can cause brain damage or death. Always read and understand instruction manual.</p>	

The first step is to determine where the vent pipe will terminate (see Figures 24, 27 & 31). The vent may terminate through a sidewall as shown in Figure 24 or through the roof as shown in Figure 27.

Important: The vent system must terminate so that proper clearances are maintained as cited in local codes or the current edition of the National Fuel Gas Code, (ANSI Z223.1, 12.9.1 through 12.9.4) and as listed below:

- Vent Termination must extend a minimum of 18 in. (46cm) above roof or 18 in. (46cm) above the anticipated snow level to prevent blockage of the vent termination, as shown in Figures 24 and 27.

Instructions on proper installation through a sidewall are provided in Figure 31.

Plan the vent system layout so that proper clearances are maintained from plumbing and wiring.

Vent pipes serving power vented appliances are classified by building codes as “vent connectors”. Required clearances from combustible materials must be provided in accordance with information in this manual under “Facts to Consider About Location” and with the National Fuel Gas Code and local codes.

VENT PIPE TECHNIQUES

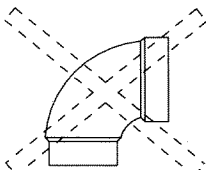
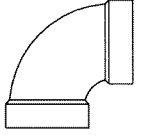
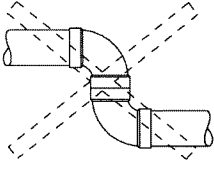
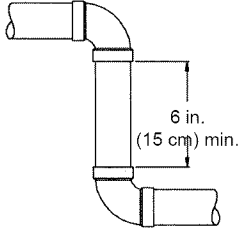
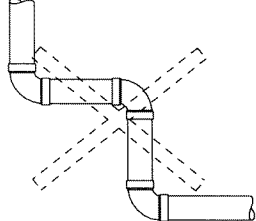
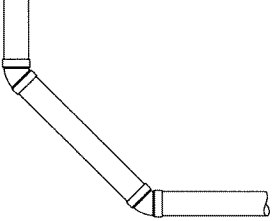
NOT RECOMMENDED:	PREFERRED PRACTICE:
 <p style="text-align: center;">STREET ELBOW</p>	 <p style="text-align: center;">NORMAL ELBOW</p>
 <p style="text-align: center;">BACK TO BACK ELBOWS</p>	 <p style="text-align: center;">6 in. (15 cm) min.</p>
 <p style="text-align: center;">90° SHORT SWEEP ELBOW (MORE RESTRICTIVE)</p>	 <p style="text-align: center;">90° LONG SWEEP ELBOW (LESS RESTRICTIVE)</p>

FIGURE 19

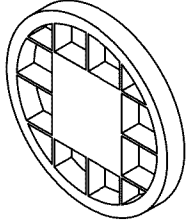
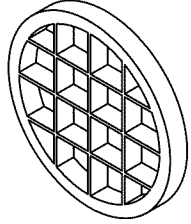
 <p style="text-align: center;">VENT LENGTH LESS THAN OR EQUAL TO 20 EQUIVALENT FEET (6.1m) USE THIS RODENT SCREEN.</p>	 <p style="text-align: center;">VENT LENGTH GREATER THAN 20 EQUIVALENT FEET (6.1m) USE THIS RODENT SCREEN.</p>
---	---

FIGURE 20

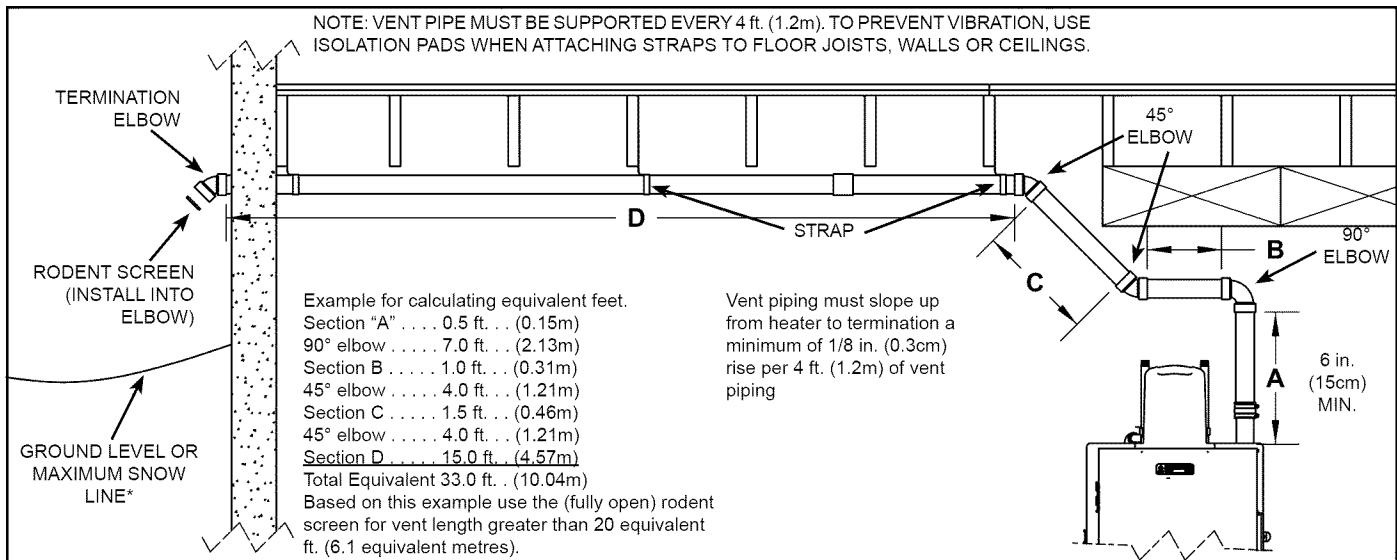


FIGURE 21

PLANNING THE VENT SYSTEM

Plan the route of the vent system from the exhaust elbow to the planned location of the vent terminal.

1. Layout total vent system to use a minimum of vent pipe and elbows. Refer to Figure 21.
2. This water heater is capable of venting flue gases a minimum distance of 10 ft. (0.3m), a maximum distance equivalent to 50 ft. (15.2m) of 2 in. pipe or 100 ft. (30.5m) of 3 in. pipe. The use of elbows reduces the maximum distance (see Figure 19 and Table 1).

NOTE: The lengths of pipe listed are exclusive of the termination. The termination elbow, with an installed rodent screen, is required and uses the equivalent of 7 ft. (2.1m) of vent pipe length. Therefore, the remainder of the vent system must not exceed the lengths listed.

NOTE: Do NOT use Cellcore venting (PVC outer layer, foamcore-type material for middle layer, and then PVC inside layer).

Number of 90° Elbows	Maximum vent length for 2 in. pipe ft. (m)		Maximum vent length for 3 in. pipe ft. (m)	
	Short Radius Elbow	Long Radius Elbow	Short Radius Elbow	Long Radius Elbow
1	43 (13.1)	45 (13.7)	93 (28.4)	95 (28.9)
2	36 (10.9)	40 (12.2)	86 (26.2)	90 (27.4)
3	29 (8.8)	35 (10.6)	79 (24.0)	85 (25.9)
4	22 (6.7)	30 (9.1)	72 (21.9)	80 (24.4)
5	15 (4.5)	25 (7.6)	65 (19.8)	75 (22.8)

TABLE 1

3. The exhaust elbow assembly comes with a straight section of 2 in. pipe installed. To continue the vent system, a rubber coupling must be attached. The venting must extend 6 in. (15cm) vertically from the top of the heater before installing an elbow.

If using 2 inch vent pipe:

Install the rubber coupling and gear clamps (supplied) at the end of the section of vent pipe installed on the heater. Continue building the vent system, or connect the existing vent system to the coupling. The total vent system must not exceed the lengths discussed above, where each (short radius) elbow is equal to 7 equivalent feet (2.1m) of straight pipe. The 2 in. elbow and appropriate rodent screen (determined by the equivalent feet of vent length) supplied in the vent kit must be used as the vent termination (see Figure 20).

If using 3 inch vent pipe:

Install the rubber reducing coupling (2 in. to 3 in.) and gear clamps (supplied) at the end of the section of vent pipe installed on the heater. Continue building the vent system, or connect the existing vent system to the coupling. The total system must not exceed the equivalent pipe lengths discussed above where each (long radius) elbow is equal to 5 ft. (1.5m) of 3 in. diameter straight vent pipe. The 3 in. elbow and stainless steel rodent screen supplied in the vent kit must be used as the vent termination.

NOTE: This unit can be vented with PVC pipe materials (DWV ASTM-D2665; Schedule 40, 80, 120 ASTM-D1785; or SDR Series ASTM-D2241), CPVC pipe materials (CPVC41 ASTM-D2846; Schedule 40, 80 ASTM-F441; or SDR Series ASTM-F442), ABS pipe materials (Schedule 40 DWV ASTM-D2661). The fittings, other than the TERMINATION should be equivalent to PVC-DWV fittings meeting ASTM D-2665 (Use CPVC fittings, ASTM F-438 for CPVC pipe and fittings, ASTM D-2661/3311 for ABS pipe). If CPVC or ABS pipe and fittings are used, then proper cement must be used for all joints, including joining the pipe to Termination (PVC Material). If local codes do not allow the use of the PVC termination when a material other than PVC is used for venting, then an equivalent fitting of that material may be substituted if the screen in the

PVC terminal is removed and inserted into the new fitting.

This water heater is supplied with a 45 degree termination elbow that is a special fitting that must be used with the appliance.

PVC Materials should use ASTM D-2564 Grade Cement; CPVC Materials should use ASTM F-493 Grade Cement and ABS Materials should use ASTM D-2235 Grade Cement.

If the water heater is being installed as a replacement for an existing power vented heater in pre-existing venting, a thorough inspection of existing venting system must be performed prior to any installation work. Verify that correct material as detailed above has been used, and that the minimum or maximum vent lengths and terminal location as detailed in this manual have been met. Carefully inspect the entire venting system for any signs of cracks or fractures, particularly at joints between elbows and other fittings and straight runs of vent pipe. Check system for signs of sagging or other stresses in joints as a result of misalignment of any components in the system. If any of these conditions are found, they must be corrected in accordance with the venting instructions in this manual before completing installation and putting the water heater into service.

NOTE: (A.) For water heaters in locations with high ambient temperatures (above 100°F (38°C)) it is recommended that CPVC or ABS pipe and fittings be used. (B.) A 22.5 degree elbow (2 in. vent pipe) or a 45 degree elbow (3 in. vent pipe) with an installed screen VENT TERMINAL must be used in all cases.

4. There will be some installations where condensate will be formed in the horizontal runs of the vent system. This condensate will run into the condensate trap. The water heater is shipped with a condensate tube that attaches to the condensate trap. No other tee or fitting is required. Refer to the section titled "Condensate".

INSTALLATION OF VENT SYSTEM

Before beginning installation of piping system thoroughly read the "Vent Pipe Preparation" section of this manual.

If you are installing your system so that it vents through roof, please refer to the section titled "Installation Of Vertical Vent System".

Ensure the vent length is long enough that the outside air will not cause the water heater to freeze.

VENT TERMINAL INSTALLATION, SIDEWALL

CAUTION

Vent terminals supplied with heater must be used.

NOTE: BEFORE BEGINNING INSTALLATION OF ANY VENT PIPE READ THE VENT PIPE MANUFACTURER'S INSTALLATION INSTRUCTIONS.

1. After the points of termination have been determined, install the vent terminal by using the cover plate as a template to mark the hole for the vent pipe to pass through the wall. **BEWARE OF CONCEALED WIRING AND PIPING INSIDE THE WALL.**
2. If the Vent Terminal is being installed on the outside of a finished wall, it may be easier to mark both the inside and outside wall. Align the holes by drilling a hole through the center of the template from the inside through to the outside. The template can now be positioned on the outside wall using the drilled hole as a centering point for the template.
3. A) MASONRY SIDEWALLS
Chisel an opening approximately 1/2 in. (1.3cm) larger than the marked circle.
B) WOODEN SIDEWALLS
Drill a pilot hole approximately 1/4 in. (0.64cm) outside of the marked circle. This pilot hole is used as a starting point for a saws-all or sabre saw blade. Cut around the marked circle staying approximately 1/4 in. (0.64cm) outside of the line. (This will allow the vent to easily slide through the opening. The resulting gap will be covered up by the Vent Terminal cover plate.) Repeat this step on inside wall if necessary.
4. Cut a length of vent pipe about 3.5 in. (9cm) longer than the wall thickness at the opening.
5. Glue the vent terminal to the section of the pipe.
6. Slide the wall plate over pipe to stop against the vent terminal.
7. Place a bead of caulking (not supplied) around the gap between the pipe and the wall. Place some of the caulking on the back of the plate to hold it against the wall after installation.
8. If the vent pipe is installed up to the wall, with a coupling on the end against the wall opening, the pipe with the vent terminal can be prepared for gluing before inserting through the wall. Slide the pipe through the wall and insert into coupling on the other side of the wall, making sure that the vent terminal ends up pointed in the correct position (see Figure 22).

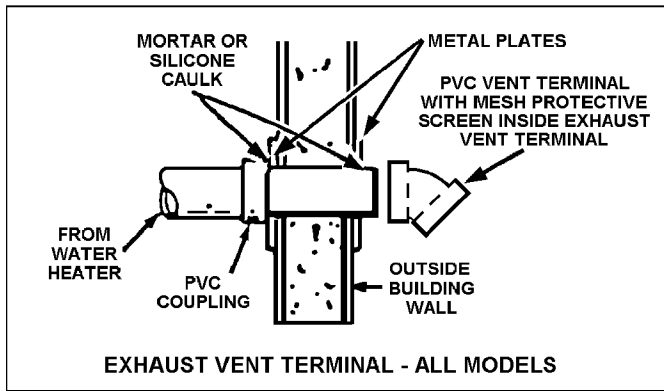


FIGURE 22

INSTALLATION OF VENT SYSTEM, SIDEWALL

With the route of the venting system and selection of materials completed, as discussed in the section of this manual titled "Planning The Vent System", the through-the-wall vent terminal in place and the first section of piping, up to first elbow, installed at the rubber coupling, it is time to complete the installation of the venting system for the sidewall installation.

Before completing the installation of the venting system be sure to read the sections of this manual discussing the proper method of cutting and cementing PVC pipe and fittings in the "Vent Pipe Preparation" section.

It is recommended that the completion of the venting system start at the rubber coupling and run to the coupling on the inside wall of the vent terminal (see Figure 23).

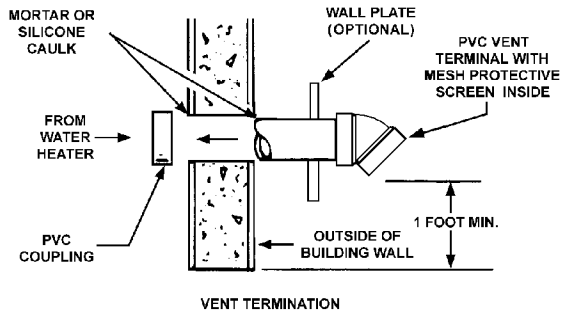


FIGURE 23

The vent system piping should be supported every 5 ft. (1.5m) of vertical run and every 3 ft. (91cm) of horizontal run. All piping and fittings must be joined by the proper procedures as described under "Vent Pipe Preparation".

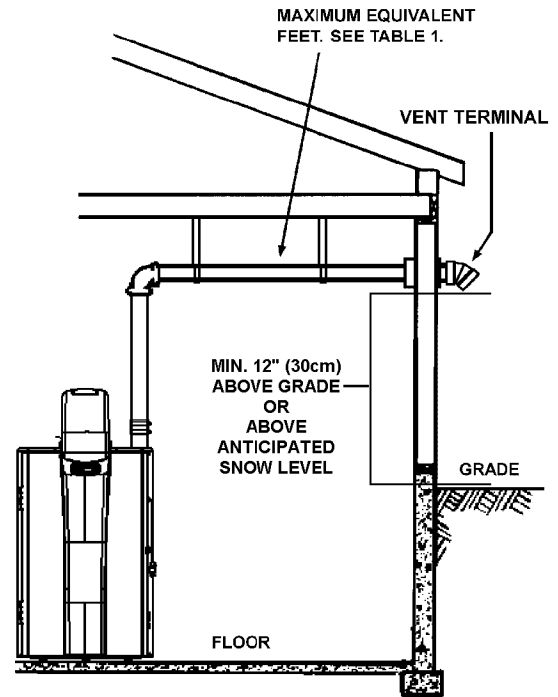


FIGURE 24

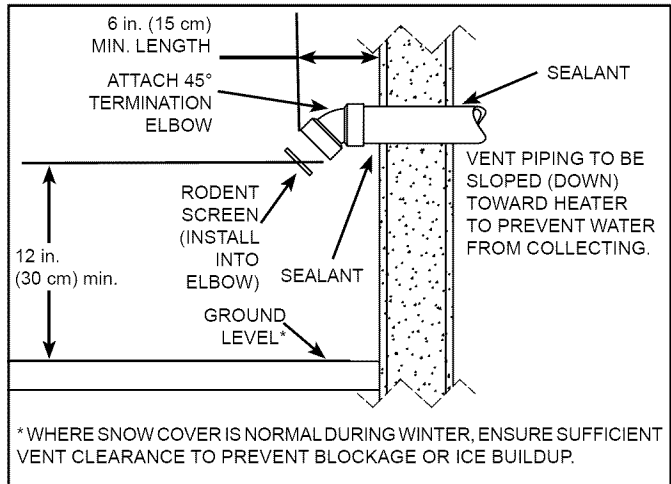


FIGURE 25

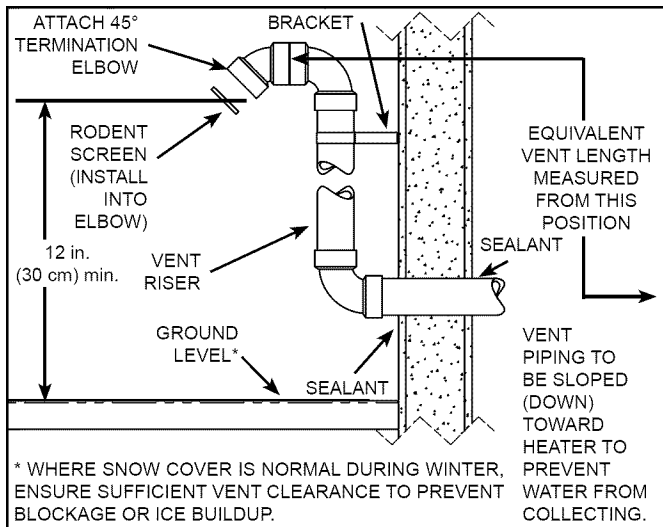


FIGURE 26

INSTALLATION OF VERTICAL VENT SYSTEM

A proper flashing or “BOOT” should be used to seal the pipe where it exits the roof. The total vent system should not exceed the equivalent feet of pipe as listed in Table 1.

Provide support for all pipe protruding through the roof. All piping should be properly secured. The vent system piping should be supported every 5 ft. (1.5m) of vertical run and every 3 ft. (91cm) of horizontal run. All piping and fittings must be joined by the proper procedures as described under “Vent Pipe Preparation”.

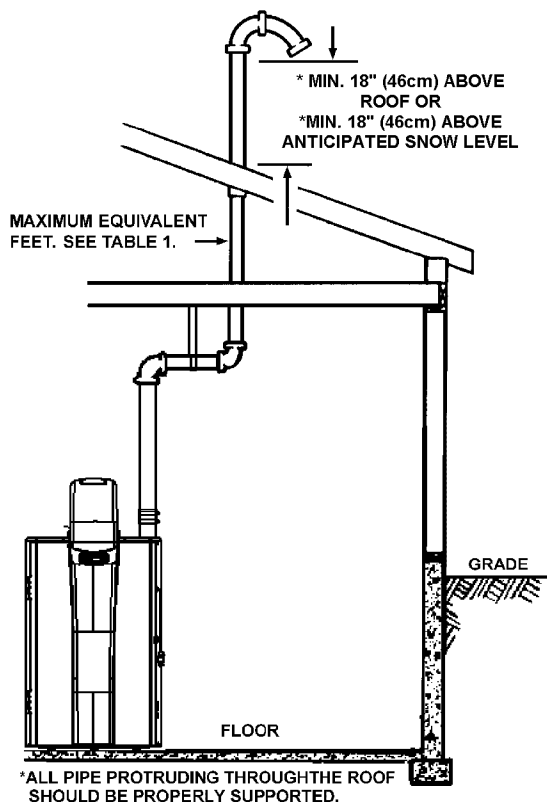


FIGURE 27

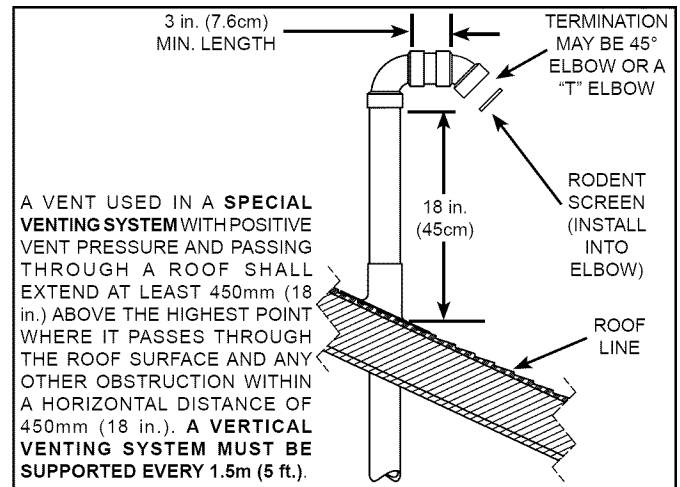


FIGURE 28



VENT PIPE PREPARATION

1. INITIAL PREPARATION.

- A. Make sure the solvent cement you are planning to use is designed for the specific application you are attempting.
- B. Know the physical and chemical characteristics and limitations of the PVC and CPVC piping materials that you are about to use.
- C. Know the reputation of your manufacturer and their products.
- D. Know your own qualifications or those of your contractor. The solvent welding technique of joining PVC and CPVC pipe is a specialized skill just as any other pipe fitting technique.
- E. Closely supervise the installation and inspect the finished job before start-up.
- F. Contact the manufacturer, supplier, or competent consulting agency if you have any questions about the application or installation of PVC and CPVC pipe.
- G. Take the time and effort to do a professional job. Shortcuts will only cause you problems and delays in start-up. By far, the majority of failures in PVC and CPVC systems are the result of shortcuts and/or improper joining techniques.

2. SELECTION OF MATERIALS.

- Cutting Device - Saw or Pipe Cutter.
- Deburring Tool, Knife, File, or Beveling Machine (2 in. and above).
- Brush - Pure Bristle.
- Rag - Cotton (Not Synthetic).
- Primer and Cleaner.
- Solvent Cement - PVC for PVC Components and CPVC for CPVC Components.
- Containers - Metal or Glass to hold Primer and Cement. Select the type of PVC or CPVC materials to be used on the basis of their application with respect to chemical resistance, pressure rating, temperature characteristics, etc.
- Insertion Tool - Helpful for larger diameter pipe and fittings 6 in. (15cm) and above.

⚠ WARNING	
Fire or Explosion Hazard	
<ul style="list-style-type: none"> • Do not store or use gasoline or other flammable vapors and liquids in the vicinity of this or any other appliance. • Avoid all ignition sources if you smell gas. • Do not expose water heater control to excessive gas pressure. • Use only gas shown on rating plate. • Maintain required clearances to combustibles. • Keep ignition sources away from faucets after extended period of non-use. 	
	<p>Read instruction manual before installing, using or servicing water heater.</p> 

APPLICATORS

Select a suitable pure bristle type paint brush. Use a proper width brush or roller to apply the primer and cement (see chart below). Speedy application of cement is important due to its fast drying characteristics. **IMPORTANT NOTE:** A dauber type applicator should only be used on pipe sizes 2 in. and below. For larger diameter pipe, a brush or roller must be used.

RECOMMENDED BRUSH* SIZE FOR PRIMER AND CEMENT APPLICATIONS	
Nominal Pipe (IPS)	Size Brush Width
2	1.5 in. (3.8cm)
3	1.5"-2.5 in. (3.8cm - 6.4cm)

*USE ONLY NATURAL BRISTLE

3. MAKING THE JOINT.

A. Cutting

Pipe must be squarely cut to allow for the proper interfacing of the pipe end and the fitting socket bottom. This can be accomplished with a miter box saw or wheel type cutter. Wheel type cutters are not generally recommended for larger diameters since they tend to flare the corner of the pipe end. If this type of cutter is used, the flare on the end must be completely removed.


NOTE: Power saws should be specifically designed to cut plastic pipe.

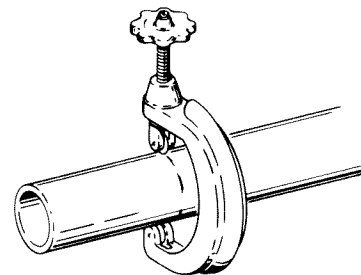
PRIMER

It is recommended that Tetrahydrofuran (THF) be used to prepare the surfaces of pipe and fittings for solvent welding. Do not use water, rags, gasoline or any other substitutes for cleaning PVC or CPVC surfaces. A chemical cleaner such as MEK may be used.

CEMENT

The cement should be a bodied cement of approximately 500 to 1600 centipoise viscosity containing 10-20% (by weight) virgin PVC material solvated with tetrahydrofuran (THF). Small quantities of dimethyl formamide (DMF) may be included to act as a retarding agent to extend curing time. Select the proper cement; Schedule 40 cement should be used for Schedule 40 pipe. Never use all-purpose cements, commercial glues and adhesives or ABS cement to join PVC or CPVC pipe and fittings.

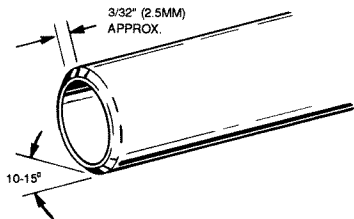
⚠ WARNING	
Fire Hazard	
	<ul style="list-style-type: none"> • Primers and cements are extremely flammable, and must not be stored or used near heat or open flame. • Also, use only in a well ventilated area.



STEP A

B. Deburring

Use a knife, plastic pipe deburring tool, or file to remove burrs from the end of small diameter pipe. Be sure to remove all burrs from around the inside as well as the outside of the pipe. A slight chamfer (bevel) of about 10°-15° should be added to the end to permit easier insertion of the pipe into the end of the fitting. Failure to chamfer the edge of the pipe may remove cement from the fitting socket, causing the joint to leak.



STEP B

C. Test dry fit of the joint

Tapered fitting sockets are designed so that an interfaced fit should occur when the pipe is inserted about 1/3 to 2/3 of the way into the socket. Occasionally, when pipe fitting dimensions are at the tolerance extremes, it will be possible to fully insert dry pipe to the bottom of the fitting socket. When this happens, a sufficient quantity of cement must be applied to the joint to fill the gap between the pipe and fitting. The gap must be filled to obtain a strong, leak-free joint.

D. Inspection, cleaning, priming

Visually inspect the inside of the pipe and fitting sockets and remove all dirt, grease or moisture with a clean dry rag. If wiping fails to clean the surfaces, a chemical cleaner must be used. Check for possible damage such as splits or cracks and replace if necessary.

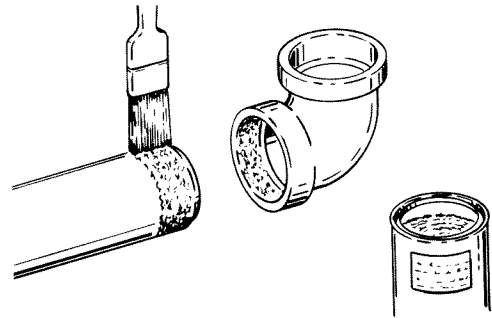
Depth-of-entry

Marking the depth of entry is a way to check if the pipe has reached the bottom of the fitting socket in Step F. Measure the fitting depth and mark this distance on the pipe O.D. You may want to add several inches to the distance and make a second mark as the primer and cement will most likely destroy your first one.

Apply primer to the surface of the pipe and fitting socket with a natural bristle brush. This process softens and prepares the PVC or CPVC for the solvent cementing step. Move quickly and without hesitation to the cementing procedure while the surfaces are still wet with primer.

E. Application of solvent cement

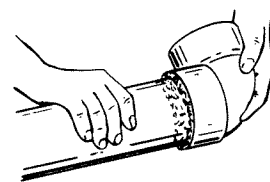
- Apply the solvent cement evenly and quickly around the outside of the pipe at a width a little greater than the depth of the fitting socket.
- Apply a light coat of cement evenly around the inside of the fitting socket. Avoid puddling.
- Apply a second coat of cement to the pipe end.



STEP E

F. Joint assembly

Working quickly, insert the pipe into the fitting socket bottom and give the pipe or fitting a 1/4 turn to evenly distribute the cement. Do not continue to rotate the pipe after it has hit the bottom of the fitting socket. A good joint will have sufficient cement to make a bead all the way around the outside of the fitting hub. The fitting will have a tendency to slide back while the cement is still wet so hold the joint together for about 15 seconds.

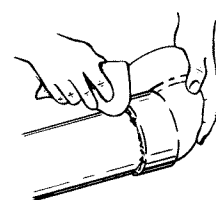


STEP F

G. Cleanup and joint movement

Remove all excess cement from around the pipe and fitting with a dry cotton rag. This must be done while the cement is still soft.

The joint should not be disturbed immediately after the cementing procedure, and sufficient time should be allowed for proper curing of the joint. Exact drying time is difficult to predict because it depends on variables such as temperature, humidity and cement integrity. For more specific information, you should contact your solvent cement manufacturer.



STEP G

CONNECTION TO VENT PIPE

The vent system connects to the vent pipe with an elbow or rubber coupling. This coupling includes gear clamps. These connections must be properly seated and tightened to prevent the leakage of flue gases into the installation area.

With 2 in. venting the straight rubber adapter is used for the connection to the vent pipe. With 3 in. venting a transition adapter is required to change from the 2 in. vent pipe to the 3 in. vent size.

Clean and lightly sand the end of the vent piping that will connect to the rubber coupling.

Loosen the upper clamp on the rubber adapter and insert the sanded end of the vent pipe and tighten the gear clamp.

NOTE: Do not glue or seal in the rubber coupling. Check the venting system to ensure that there is no stress on the connection or the vent pipe which will create a twisting or bending.

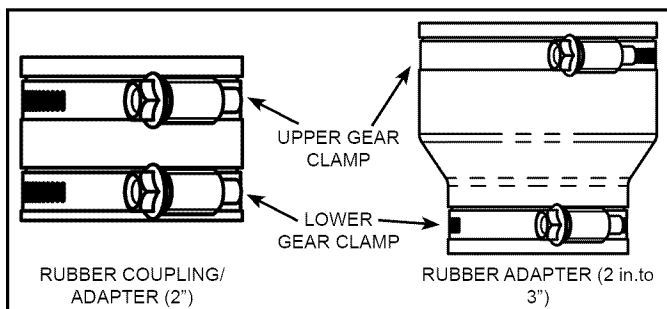


FIGURE 29

CONDENSATE

This water heater is a condensing unit and requires a drain to be located in close proximity to allow the condensate to drain safely. The condensate drains from the unit at the exhaust tee located at the bottom of the unit (see Figure 30). Condensate from this water heater is mildly acidic. Please note that some local codes require that condensate is treated by using a pH neutralizing filter prior to disposal.

Caution must be used to ensure that the drain is free and clear of debris and will not allow backflow through the condensate tube. Consideration must be given to avoid freezing of the condensate lines which could result in excessive build up of condensate inside the water heater. Waterproof heat tape may be required to prevent freezing of the condensate lines. Please ensure that the outlet of the condensate drain does not create a slippery condition which could lead to personal injury.

To operate properly and prevent exhaust gases from escaping through the condensate trap, the trap must

contain some water. Before being started for the first time, water must be added to the trap. Remove the condensate tube (if installed) and add water to the trap through the hole for the condensate tube until it flows from the hole. (Re)install the condensate tube.

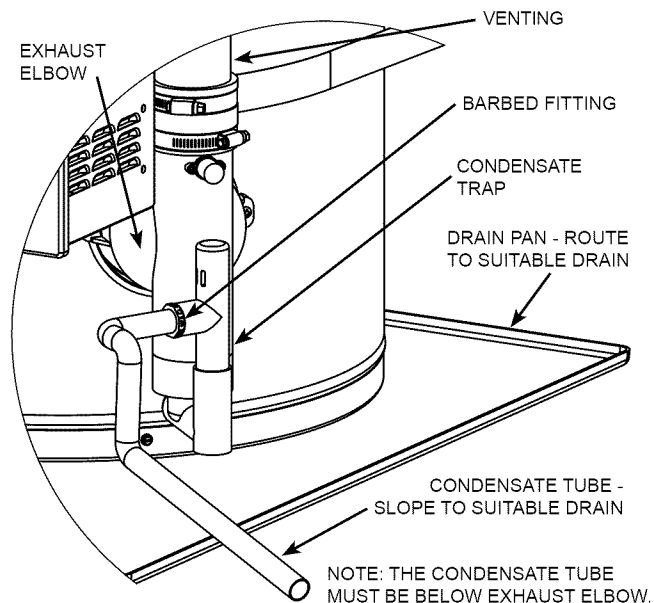


FIGURE 30

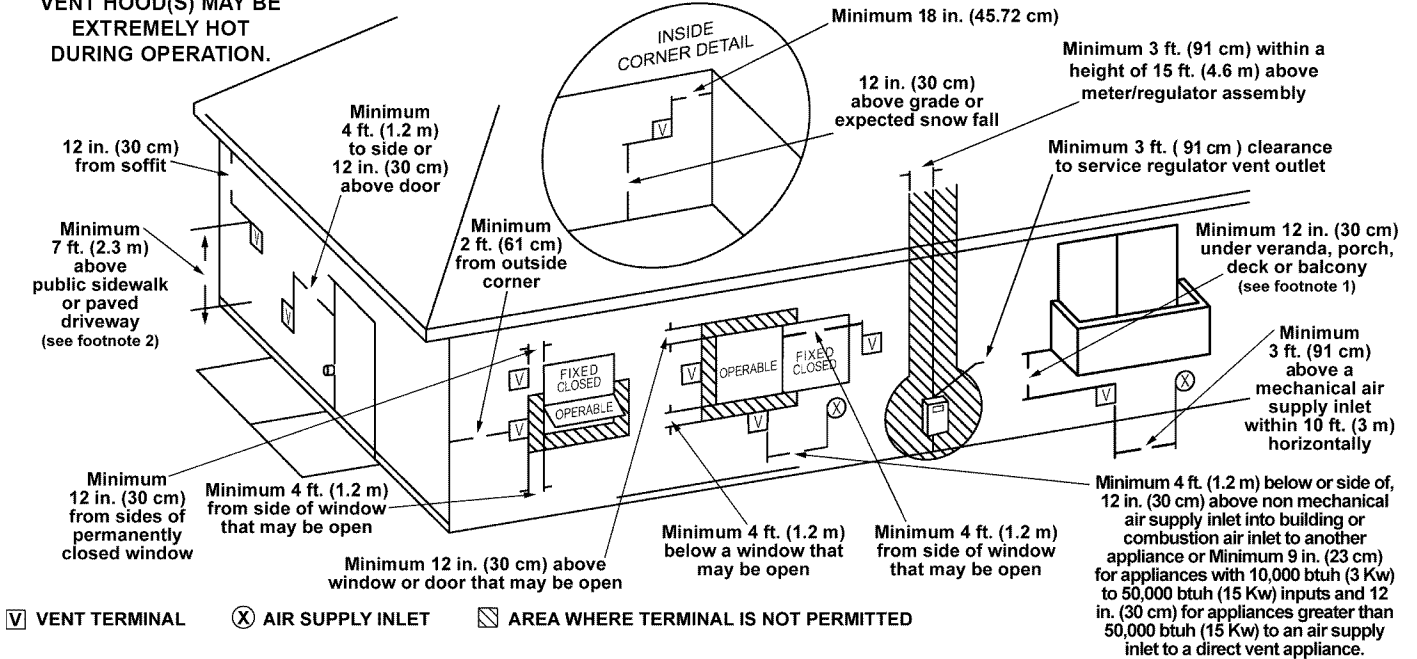
CONDENSATION WARNING:
THIS WATER HEATER IS A CONDENSING UNIT AND REQUIRES A DRAIN TO BE LOCATED IN CLOSE PROXIMITY TO ALLOW CONDENSATE TO DRAIN SAFELY. THE CONDENSATE DRAINS FROM UNIT AT THE EXHAUST ELBOW LOCATED AT BOTTOM OF UNIT.

NOTE: IT IS IMPORTANT THAT THE CONDENSATE TUBE NOT BE ELEVATED ABOVE THE CONDENSATE TRAP OUTLET (SEE FIGURE 30). CONDENSATE BUILD-UP WILL BLOCK THE EXHAUST OUTLET, WHICH WILL CAUSE IMPROPER OPERATION. WITH SOME INSTALLATIONS IT IS RECOMMENDED TO INSTALL A CONDENSATE PUMP.

NOTE: Barbed fitting not required if hard piping is used to drain condensate.

U.S. POWER VENT

⚠ WARNING
VENT HOOD(S) MAY BE
EXTREMELY HOT
DURING OPERATION.



V VENT TERMINAL
 X AIR SUPPLY INLET
 / / / / AREA WHERE TERMINAL IS NOT PERMITTED

1. Permitted only if veranda, porch, deck or balcony is fully opened on a minimum of two sides beneath the floor.
2. A vent shall not terminate above a sidewalk or paved driveway that is located between two single family dwellings and serves both dwellings.

FIGURE 31

⚠ CAUTION

TO PREVENT EXHAUSTING PRODUCTS FROM CIRCULATING TO THE AIR INTAKE IN WINDY/COLD AREAS, THE MAXIMUM PRACTICAL DISTANCE BETWEEN THESE TWO TERMINALS IS RECOMMENDED.

ELECTRICAL CONNECTIONS

The water heater must be connected to a properly grounded electrical branch circuit. A dedicated circuit is preferred. Do not use a GFI outlet.

Refer to the rating plate attached to the water heater to determine the electrical requirements for the heater. Ensure the circuit provided is correct for these requirements.

Important: Do not use an extension cord to connect the water heater to an electrical outlet.

Important: The electrical controls used inside the gas control of this water heater are polarity sensitive. Ensure the electrical supply is connected correctly in the receptacle box. Failure to connect correctly will prevent the unit from functioning properly.

When all the water, gas and venting connections have been correctly made, fill the tank as directed in the section "FILLING THE WATER HEATER".

When the tank has been filled, connect the electrical power and proceed with starting the water heater as directed in the "CALIBRATION" section.

CALIBRATION

The water heater must be calibrated as follows before being put into service. The Calibration Procedure examines and measures certain details of your installation and automatically sets some control parameters. Before starting the Calibration Procedure, the heater must be properly installed and connected to the water piping and the vent system. Ensure all panels, covers and doors are in place.

This procedure assumes that the heater is installed with DIP switch 4 in the calibration (ON) position (see Figure 32).

To calibrate the heater:

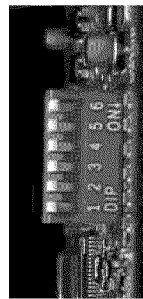
1. Plug the power cord into a 120Vac/60Hz outlet.
2. Press the ON/OFF Button to turn on the heater and initiate the Calibration Procedure. This is an automatic process that will last approximately six minutes. The display will show 120°F during the calibration procedure.
3. Once the unit has ignited turn open a nearby hot water faucet.

Important: To avoid a possible "end of call-for-heat" (and consequent interruption of the Calibration Procedure), a continuous water draw from the heater is recommended during the calibration.

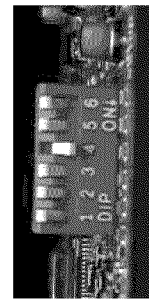
4. Do not interrupt this procedure once it has started. After a successful calibration the heater will go into standby mode and the display will show 105°F (factory default). During the calibration if the "call-for-heat" ends, the calibration was not completed and the E36 error message will be shown on the display. If this occurs, unplug the power cord and repeat steps 1 and 2.

To put the heater into service after a successful calibration:

1. Close the hot water faucet.
2. Unplug the power cord from the 120Vac/60Hz outlet
3. Open (plastic) front door of the heater and remove the service cap of the heat engine (Parts Identification Item 14.) The DIP switches are located on the PCB which is mounted on the right-hand side of the heat engine.
4. Set DIP switch 4 in the normal (OFF) position (see Figure 32).
5. Reinstall the service cap on the heat engine, close and latch the front door of the heater.
6. Plug the power cord into the 120Vac/60Hz outlet.
7. Press the Standby Button to turn on the heater and start the unit.



DIP Switch 4
in normal mode
("OFF").



DIP Switch 4
in calibration mode
("ON").

FIGURE 32

The E36 "calibration error" occurs in the following situations:

- Calibration switch (DIP switch 4) is in the calibrate (ON) position and an "end call-for-heat" occurs before the Calibration Procedure is finished.
- Calibration switch (DIP switch 4) is in the calibrate (ON) position there is no "call-for-heat" within 6 minutes of turning on the power.
- Calibration switch (DIP switch 4) is in the calibrate (ON) position and the unit is calibrated but the DIP switch is not set to the normal (OFF) within 6 minutes after the Calibration Procedure is finished.
- Calibration switch (DIP switch 4) is in the normal (OFF) position and the unit is not calibrated and 1 minute (or more) passes after turning on the power.

If an E36 error message is displayed:

1. Unplug the power cord from 120Vac/60Hz outlet.
2. Open front door of the heater and remove the service cap of the heat engine.
3. Check that (or set) DIP switch 4 is in the calibrate (ON) position.
4. Generate a 5 minute (minimum) water draw from the heater.
5. Repeat the calibration procedure.

NOTE: If changes are made to the vent system or the heater is re-located, the Calibration Procedure must be repeated.

OPERATING INSTRUCTIONS

DISPLAY PANEL

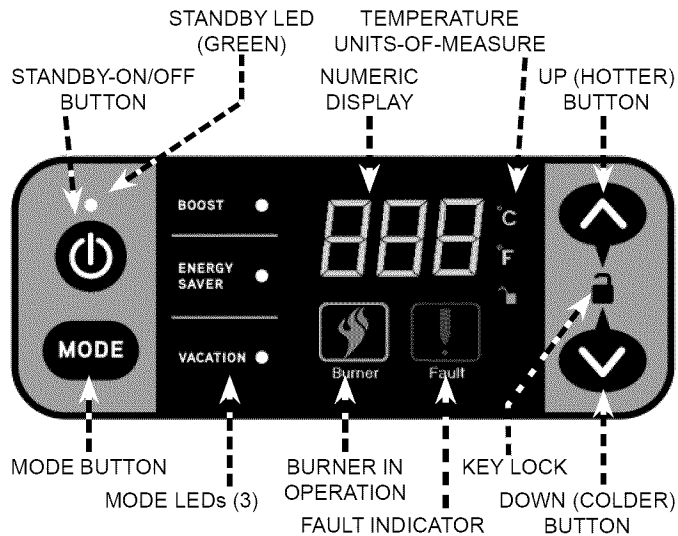


FIGURE 33

Changing the Standby Status

When the Standby Button is pressed, the Status changes to normal operation and all the LEDs on the display will light up for a period of 1 second to verify operation. The button can toggle the status between Normal operation and Standby.

Key Lock

NOTE: This is a tamper resistant feature.

The Key Lock is considered "On" or "Off":

- Key Lock is turned "On" after one minute without a key press by the user.
- Key Lock can then be turned "Off" for one minute by simultaneously pressing the "Up" Button and the "Down" Button for three seconds.

When the keys are locked, the Temperature Set-point cannot be increased and the Operating Mode cannot be changed. The set-point may be decreased while the keys are locked.

The On/Off Button is not affected by the Key Lock feature. All other buttons are "locked" when the Key Lock is "On".

The "Key Lock" icon will be displayed if the water heater is either in the lock or unlock condition. The Icon is composed of 3 components, the base, a locked and an unlocked arc.

Operating Modes

Operating modes are:

Boost (for peak demand), Energy Saver and Vacation. Three LEDs are used to indicate the Operating Mode.

Vacation Mode: Yellow LED

Energy Saver Mode: Green LED

Boost Mode: Orange LED

The Operating Modes have the following characteristics:

Vacation mode:

- Fixed temperature setting of 90°F (32°C)

Energy Saver mode:

- Temperature range from 100°F to 135°F (38°C to 57°C) in increments of 1°F or 1°C

Boost mode:

- Temperature ranges from 140°F to 158°F (60°C to 70°C) in increments of 1°F or 1°C

Switching between operating modes is done by pressing the "Mode" Button when the Key Lock is "Off". When a mode is active, the corresponding LED is turned on. Pressing the "Mode" button will cycle between the three possible modes of operation.

Numeric Display

Numeric information such as temperature set-point, maintenance codes and error codes are displayed using a large yellow LED display.

Up and Down Buttons

Two buttons (with “Up” and “Down” arrows) are used for adjusting the data on the display. Other secondary functions such as turning the Key Lock “Off”, are described in other sections.

Temperature Set-point change

Two buttons (with “Up” and “Down” arrows) are used to adjust the desired temperature set-point.

When the Temperature Set-point is displayed and the Key Lock Is “Off”, pressing the Up Button will increase the set-point and pressing the Down button will decrease the set-point.

NOTE: The Temperature Set-point cannot be adjusted beyond the limits of the current Mode selected.

Burner in Operation

When the burners are in operation and flame is detected by the flame sensor, the flame symbol is illuminated.

Switching Between Units of Measure

Switching between temperature units of measure (°F/°C). Two yellow LEDs will be used to light up the current unit mode, °F or °C. To switch units of measure, simultaneously press the “Mode” button and the “Up” button.

Fault Indication

A red fault LED (lighting a large red exclamation point) should be present on the display panel.

Diagnostic mode

By simultaneously pressing the “Mode” and “down arrow” buttons for 3 seconds the unit will allow access to the diagnostic mode.

FOR YOUR SAFETY READ BEFORE LIGHTING



WARNING: If you do not follow these instructions exactly, a fire or explosion may result causing property damage, personal injury or loss of life.



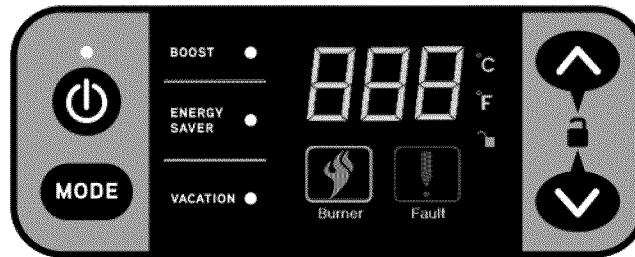
BEFORE LIGHTING: ENTIRE SYSTEM MUST BE FILLED WITH WATER AND AIR PURGED FROM ALL LINES

- A. This appliance does not have a pilot. It is equipped with an ignition device which automatically lights the burner. Do NOT try to light the burner by hand.
- B. BEFORE OPERATING smell all around the appliance area for gas. Be sure to smell next to the floor because some gas is heavier than air and will settle on the floor.
- C. If you cannot reach your gas supplier, call the fire department.
- C. Do not use this appliance if any part has been under water. Immediately contact a qualified installer or service agency to replace a flooded water heater. Do not attempt to repair the unit! It must be replaced!

WHAT TO DO IF YOU SMELL GAS

- Do not try to light any appliance.
- Do not touch any electric switch; do not use any phone in your building.
- Immediately call your gas supplier from a neighbor's phone. Follow the gas supplier's instructions.

OPERATING INSTRUCTIONS



1. **STOP!** Read the safety information above on this label.
2. Ensure tank is filled with water and the gas line is connected.
3. This appliance is equipped with a device which automatically lights the burner. DO NOT TRY TO LIGHT THE BURNER BY HAND.
4. Wait five (5) minutes to clear out any gas. If you smell gas, **STOP!** Follow "B" in the safety information above on this label. If you don't smell gas:
5. Turn on all electrical power to the appliance.
6. If the green light above the stand-by button is flashing, press the stand-by button. If the green light is turned off then the water heater will automatically light the burners.
7. Set the display to the desired setting. CAUTION: Hotter water increases the risk of scald injury. Consult the instruction manual before changing temperature.
8. If the appliance will not operate, follow the instructions "TO TURN OFF GAS TO APPLIANCE" and call your technician or gas supplier.



DANGER: Hotter water increases the risk of scald injury. Consult the instruction manual before changing temperature.

TO TURN OFF GAS TO APPLIANCE

1. Press the ON/OFF button to set the heater in standby mode (display OFF and power LED ON).
2. Unplug the heater from 120Vac/60Hz outlet if service is to be performed..

TEMPERATURE REGULATION

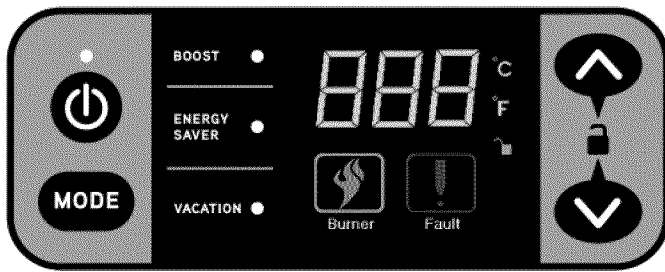


FIGURE 35

It is recommended that lower water temperatures be used to avoid the risk of scalding. It is further recommended, in all cases, that the water temperatures be set for the lowest temperature which satisfies your hot water needs. This will also provide the most energy efficient operation of the water heater.

	<p>⚠ DANGER Water temperature over 125°F (52°C) can cause severe burns instantly resulting in severe injury or death.</p> <p>Children, the elderly, and the physically or mentally disabled are at highest risk for scald injury.</p> <p>Feel water before bathing or showering.</p> <p>Temperature limiting valves are available.</p> <p>Read instruction manual for safe temperature setting.</p>
--	--

HOT WATER CAN SCALD: Water heaters are intended to produce hot water. Water heated to a temperature which will satisfy space heating, clothes washing, dish washing, and other sanitizing needs can scald and permanently injure you upon contact. Some people are more likely to be permanently injured by hot water than others. These include the elderly, children, the infirm, or physically/mentally handicapped. If anyone using hot water from this heater fits into one of these groups or if there is a local code or state law requiring a certain temperature water at the hot water tap, then you must take special precautions. In addition to using the lowest possible temperature setting that satisfies your hot water needs, a means such as a mixing valve, should be used at the hot water taps used by these people or at the water heater. Mixing valves are available at plumbing supply or hardware stores (see Figure 3). Follow manufacturer's instructions for installation of the valves. Before changing the factory setting on the thermostat, read the "Temperature Regulation" section in this manual.

Never allow small children to use a hot water tap, or to draw their own bath water. Never leave a child or handicapped person unattended in a bathtub or shower.

The water heater should be located in an area where the general public does not have access. If a suitable area is not available, a cover should be installed over the thermostat to prevent tampering. The water temperature setting was factory set at the lowest temperature;

THIS WATER HEATER IS EQUIPPED WITH AN ADJUSTABLE THERMOSTAT TO CONTROL WATER TEMPERATURE. HOT WATER TEMPERATURES REQUIRED FOR AUTOMATIC DISHWASHER AND LAUNDRY USE CAN CAUSE SCALDBURNS RESULTING IN SERIOUS PERSONAL INJURY AND/OR DEATH. THE TEMPERATURE AT WHICH INJURY OCCURS VARIES WITH THE PERSON'S AGE AND THE TIME OF THE EXPOSURE. THE SLOWER RESPONSE TIME OF CHILDREN, AGED OR DISABLED PERSONS INCREASES THE HAZARDS TO THEM. NEVER ALLOW SMALL CHILDREN TO USE A HOT WATER TAP, OR TO DRAW THEIR OWN BATH WATER. NEVER LEAVE A CHILD OR DISABLED PERSON UNATTENDED IN A BATHTUB OR SHOWER.

THE WATER HEATER SHOULD BE LOCATED IN AN AREA WHERE THE GENERAL PUBLIC DOES NOT HAVE ACCESS TO SET TEMPERATURES.

SETTING THE WATER HEATER TEMPERATURE AT 120°F (49°C) WILL REDUCE THE RISK OF SCALDS. Some states require settings at specific lower temperatures.

The water temperature is controlled using the Temperature Control on the Display at the front of the unit (see Figure 3). This control utilizes a temperature probe to determine the tank temperature. The primary temperature probe is located at the bottom of the tank.

The temperature may be adjusted from 90°F (32°C) to 158°F (70°C). The thermostat was adjusted to 105°F (40°C) before the heater was shipped from the factory. It is recommended that lower water temperature be used to avoid the risk of scalding. It is further recommended, in all cases, that the water temperature be set for the lowest temperature which satisfies your hot water needs. This will also provide the most energy efficient operation of the water heater and minimize scale formation.

Valves for reducing the point-of-use temperature by mixing cold and hot water are available (see Figure 3). Also available are inexpensive devices that attach to faucets to limit hot water temperatures. Contact a licensed plumber or the local plumbing authority.

The table below shows the approximate time-to-burn relationship for normal adult skin. Short repeated heating cycles caused by small hot water uses can cause temperatures at the point of use to exceed the thermostat setting by up to 20°F (11°C). If you experience this type of use, you should consider using lower temperature settings to reduce scald hazards.

Water Temperature	Time for 1st Degree Burn (Less Severe Burns)	Time for Permanent Burns 2nd & 3rd Degree (Most Severe Burns)
110°F (44°C)	(normal shower temp.)	
116°F (47°C)	(pain threshold)	
116°F (47°C)	35 minutes	45 minutes
122°F (50°C)	1 minute	5 minutes
131°F (55°C)	5 seconds	25 seconds
140°F (60°C)	2 seconds	5 seconds
149°F (65°C)	1 second	2 seconds
154°F (68°C)	instantaneous	1 second

(U.S. Government Memorandum, C.P.S.C., Peter L. Armstrong, Sept. 15,1978)

TABLE 2

Setting Desired Temperatures

1. Set the key lock to the “Off” position
2. Select the desired mode button (vacation, energy saver or boost)
3. Using the arrow buttons select the desired temperature

Key Lock

NOTE: This is a tamper resistant feature.

The Key Lock is considered “On” or “Off”:

- Key Lock is turned “On” one minute after the unit has been plugged in.
- Key Lock can then be turned “Off” for one minute by simultaneously pressing the “Up” Button and the “Down” Button for three seconds.

When the keys are locked, the Temperature Set-point cannot be increased or decreased, and the Operating Mode cannot be changed.

The On/Off Button is not affected by the Key Lock feature. All other buttons are “locked” when the Key Lock is “On”.

A lock or unlock LED icon will display the condition. The Icon will be composed of 3 components, the base, a locked and an unlocked arc.

Operating Mode Selection

Operation modes are: Boost (peak demand), Energy Saver and Vacation.

Initial conditions after starting-up the control is determined by evaluation of the stored set-point.

Vacation Mode is selected if the Temperature Set-point value is less than 100°F (38°C). Boost Mode is selected if the Temperature Set-point value is greater than or equal to 140°F (60°C). Energy Saver Mode is selected for all other Temperature set-point values.

Three LED’s are used to indicate the Operating Mode Selection

- Vacation Mode: Yellow LED
- Energy Saver Mode: Green LED
- Boost Mode: Orange LED

The Operating Modes have the following characteristics:

Vacation mode:

- Fixed temperature setting of 90°F (32°C)

Energy Saver mode:

- Temperature range from 100°F to 135°F (38°C to 57°C) in increments of 1°F or 1°C

Boost mode:

- Temperature range from 140°F to 158°F (60°C to 70°C) in increments of 1°F or 1°C

Switching between operation modes is done by pressing the “Mode” Button when the Key Lock is “Off”. When a mode is active, the corresponding LED is turned on. Pressing the “Mode” button will cycle between the three possible modes of operation.

Each time the “Mode” Button is changed by the user, the controller display is to respond with the following actions:

1. The Temperature Set-point changes to the lowest temperature for the respective mode (e.g. 100°F (38°C) for “Energy Saver” and 140°F (60°C) for “Boost” mode) and is communicated to the master device.
2. The LED corresponding to the new mode is turned on.

UNIQUE HYBRID FEATURES

Temperature Measurement

Temperature Probes

The water heater has support for three independent temperature probes:

1. Water Inlet Temperature Probe
The water inlet temperature probe contains a thermistor and measures the temperature of the water entering the heat engine enclosure.
2. Water Outlet Temperature Probe
The water outlet temperature probe contains a thermistor and measures the temperature of the water leaving the heat engine enclosure. This supply of (hot) water is delivered to the top of the storage tank in close proximity to the outlet fitting.
3. Tank Temperature Probe
The tank probe contains a thermistor and measures the temperature of the water in the storage tank at a specific location between the top and the bottom of the tank.

Water Circulation Pump

A circulation pump is integrated into the heat engine for the Hybrid application. The pump serves to push water through the heat engine at a rate that supports optimum recovery time and maximum heat output.

The control provides 120Vac, 60Hz line power to the pump to enable operation.

Water Flow Measurement

1. Water Flow Sensor

The Water Flow Sensor uses a sensor for the detection of the water flow. When water flows, the sensor rotates and a transistor is switched on and off, producing a pulsing signal with a frequency related to flow rate.

2. Water Flow Detection

Flow detection is an on/off indication of whether there is sufficient flow through the heat exchanger for normal heating.

3. If the water is less than 0.58 gal/min (2.2 l/min) the unit stops and will start again when the flow is above 0.72 gal/min (2.7 l/min).

Water Flow Restriction Valve

A motorized valve is placed in series with the circulation pump and the heat exchanger of the heat engine. This valve serves to limit the amount of flow through the heat engine such that a variable rate of flow can be achieved from the fixed-speed pump.

Gas Delivery Safety String

The release of gas into the combustion chamber is of critical importance to the safe operation of the heater. The control is a combination of hardware and software that measure and ensure the gas is released only when appropriate for combustion. The term “safety string” applies to those devices or components that directly control the power applied to the gas valves as well as the gas valves themselves. The components are:

- main gas valve solenoid,
- stage 1 and 2 gas valve solenoids,
- exhaust vent High Temperature Switch,
- energy cut out (ECO) Switch.

High Temperature Switch

The water heater is designed for plastic vent piping typically used in high efficiency appliances. To ensure the water heater will not release exhaust gasses at temperatures that would cause the vent piping to melt, a bimetallic switch is mounted on the assembly. The switch used is a normally-closed switch which will open when the temperature reaches the maximum design temperature for the venting used. This switch should reset to the closed position when the vent pipe temperature cools sufficiently.

- Opening Temperature is approximately 165°F (74°C) +/- 5°F (2.8°C).
- Closing Temperature is approximately 135°F (57°C) +/- 5°F (2.8°C).

The power for the main gas valve is to be routed through the High Temperature Switch causing the main gas valve to be de-energized immediately when the switch opens. The status of the High Temperature Switch should be continually monitored by the controller. If an open is detected, the control should declare a fault and respond according to the fault. The fault is a continuous lockout.

Energy Cut Out (ECO) Switch

The heat exchanger of the heat engine is equipped with a surface-mounted bimetallic switch which opens when the water temperature exceeds the safe operating temperature for the water heater.

- Opening Temperature is 185°F +/-9°F (85°C +/-5°C)
- Closing Temperature is 149°F +/-6°F (65°C +/-3°C)

The power from the main gas valve is to be routed through the ECO Switch causing the main gas valve to be immediately de-energized when the switch opens.

The status of the ECO Switch should be continually monitored by the controller. If an open switch is detected, the control should declare a fault and respond according to the fault. This will be a continuous lockout.

Blocked (Exhaust Gas) Outlet Detection

If the exhaust air passage is obstructed, the control is to enter a fault state and initiate a controlled shut down. This is an overall safety feature of the control system.

Igniter

The control has an integrated direct spark ignition, which can turn on, by means of a relay. This feature is integrated onto the controller board.

By default, the control will allow for three ignition tries. If ignition cannot be achieved, the control will end ignition attempts, prevent any more heating cycles and display the E28 error message (soft lockout) to the user.

Flame Sensor

An active flame is sensed through a flame sensor located in the burner assembly in the region of the burners flame. The flame sense input will be monitored by the control and respond to the presence of the flame.

Combustion Chamber Temperature Protection (High-Limit Fuse)

If the temperature increases over 287.6°F (142°C) the High-Limit Fuse will melt. This action disconnects the power supply controller. The High-Limit Fuse must be replaced.

Line Voltage Monitor

The control monitors the line voltage provided to the system. If the line voltage is too low, the system components may not operate properly. For diagnostic purposes, the display panel should indicate that the cause was power-related.

- If line power is below 102Vac, the water heater will enter the fault state and initiate a controlled shut-down. The fault will automatically clear if the voltage is restored to 102Vac or above.
- If line power is above 132Vac, the water heater will enter the fault state and initiate a controlled shut-down. The fault will automatically clear if the voltage is restored to 132Vac or below.

TEMPERATURE REGULATION

Temperature regulation is the process by which the controller determines when the water heater is to heat water as well as when to stop the heating process. This section defines how the water heater is to regulate the temperature.

Temperature Units of Measure

The water heater control will display the temperatures in either °C or °F (as per selected unit of measure). The main temperature unit is °C and all the calculations, within the control system, are done using temperature values in °C. The display has the capability to perform a conversion from °C to °F. The resulting temperatures in °F will be rounded off to the nearest degree.

Temperature Set-point

The adjustable temperature set-point is used to determine the desired outlet temperature of the water heater.

The water outlet of the heat engine feeds the outlet of the storage tank although some mixing does occur with the water at the top of the storage tank. For this reason, the temperature of water delivered is considered equivalent to the heat engine output temperature.

This value is to be set within the acceptable range of 90°F (32°C) and 158°F (70°C) when selecting the operating modes.

As a safety measure, the control is to ensure that the set-point cannot be adjusted outside of this range.

If the water flow is turned off and then is turned on, the controller remembers and automatically resets to the last temperature.

If a power outage occurs or the unit is energized/de-energized by the STANDBY symbol for re-booting, the controller resets to the last temperature setting.

After clearing a continuous lockout error code the unit will always go back to the factory default temp setting and mode.

Storage Tank Set-point

The control is required to maintain a storage tank set-point differential temperature.

Storage Tank Call For Heat

The storage tank call for heat is generated when the tank thermistor temperature drops below the storage tank set-point minus the fixed storage tank differential.

At the end of a call for heat the tank thermistor's temperature is equal to or greater than the storage tank set-point.

Temperature Control Modes

The temperature control functions can operate under one of the pre-defined user-selected control modes. The temperature control mode serves to limit the range of the (heat engine) temperature set-point and the storage tank differential.

Please reference the Operating Mode Selection for details of how the set-point and differentials are adjusted for the different modes. In brief, three modes are provided: Vacation Mode, Energy Saver Mode, and Boost Mode.

The temperature control mode will be maintained after a power loss. Upon restoring power, the temperature set-point is set to the last temperature.

The default setting is 105°F (41°C) in the Energy Saver Mode.

Outlet Temperature Limit Control

Your water heater is designed to provide a constant outlet water temperature. The water heater takes into account dynamic conditions of the heat engine such as the inlet water temperature, flow rate, gas flow adjustment, etc and establishes the optimum performance.

The control will end the call for heat if the outlet thermistor temperature exceeds the set-point by a fixed amount.

The call for heat may be restored if the outlet thermistor temperature drops below the set-point by 5.4°F (3°C) or more.

Inlet Temperature Limit Control

To add protection to the system, an over-temperature comparison is made on the inlet water temperature.

The water heater will end the call for heat if the inlet thermistor temperature is above the set-point.

The call for heat may be restored if the inlet thermistor temperature drops below the set-point.

CONSTANT OUTPUT TEMPERATURE CONTROL

While the temperature regulation in the previous section describes the features of temperature monitoring and regulation, your water heater goes beyond the on/off control implied there and implements a gas, air and water flow modulation scheme to provide a constant water delivery temperature from the heat engine for the duration of the call for heat.

Heat Needed during Normal Operation

The amount of heat needed is based on the amount of water flowing through the heater and the amount of temperature rise that needs to be generated to meet your demands. The system will calculate the amount of heat needed.

The temperature regulation will prevent the inlet temperature from reaching the temperature set-point.

Detection of Failure to Maintain Desired Constant Temperature

This check can be used to detect a failure of the stage 2 gas valve. In this case, an insufficient amount of heat would be applied. This check can also serve to diagnose failures or mis-wiring of the water flow restriction valve. If the valve fails to restrict the flow of water, the system may not be able to sufficiently heat the water passing through the heat engine.

A failure to maintain the desired constant temperature is determined by the outlet water temperature remaining 15 degrees lower than the set-point for one minute while the flame is established. If this condition is detected while in the heating state for normal modes, an Alert message is provided to the display panel.

START UP CONDITIONS

Smoke/Odor

It is not uncommon to experience a small amount of smoke and odor during the initial start-up. This is due to burning off of oil from metal parts, and will disappear in a short while.

Strange Sounds

Possible noises due to expansion and contraction of some metal parts during periods of heat-up and cool-down do not necessarily represent harmful or dangerous conditions.

Condensation causes sizzling and popping within the burner area during heating and cooling periods and should be considered normal. See "CONDENSATE" section.

OPERATIONAL CONDITIONS

Smelly Water

In each water heater there is installed at least one anode rod (see parts section) for corrosion protection of the tank. Certain water conditions will cause a reaction between this rod and the water. The most common complaint associated with the anode rod is one of a "rotten egg smell" in the hot water. The smell is a result of four factors which must all be present for the odor to develop:

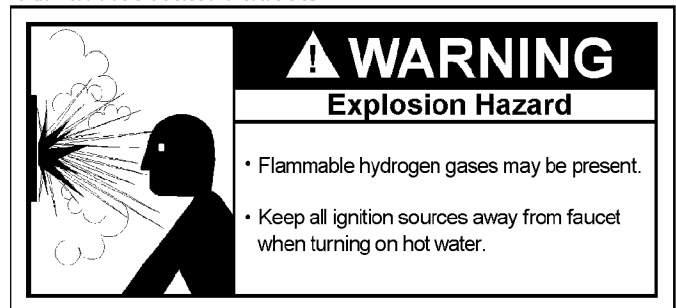
- A concentration of sulfate in the supply water.
- Little or no dissolved oxygen in the water.
- A sulfate reducing bacteria which has accumulated within the water heater (this harmless bacteria is nontoxic to humans).
- An excess of active hydrogen in the tank. This is caused by the corrosion protective action of the anode.

Smelly water may be eliminated or reduced in some water heater models by replacing the anode(s) with one of less active material, and then chlorinating the water heater tank and all water lines. Contact Sears Service for further information concerning an Anode Replacement Kit and this chlorination treatment.

If the smelly water persists after the anode replacement and chlorination treatment, we can only suggest that chlorination or aeration of the water supply be considered to eliminate the water problem.

Do not remove the anode leaving the tank unprotected. By doing so, all warranty on the water heater tank is voided.

"Air" In Hot Water Faucets



HYDROGEN GAS: Hydrogen gas can be produced in a hot water system that has not been used for a long period of time (generally two weeks or more). Hydrogen gas is extremely flammable and explosive. To prevent the possibility of injury under these conditions, we recommend the hot water faucet, located farthest away, be opened for several minutes before any electrical appliances which are connected to the hot water system are used (such as a dishwasher or washing machine). If hydrogen gas is present, there will probably be an unusual sound similar to air escaping through the pipe as the hot water faucet is opened. There must be no smoking or open flame near the faucet at the time it is open.

MAINTENANCE

HOUSEKEEPING

Vacuum around base of water heater for dust, dirt, and lint on a regular basis.

VENTING SYSTEM INSPECTION

At least once a year a visual inspection should be made of the venting system. You should look for:

1. Obstructions which could cause improper venting. The combustion and ventilation air flow must not be obstructed.
2. Damage or deterioration which could cause improper venting or leakage of combustion products.

Be sure the vent piping is properly connected to prevent escape of dangerous flue gasses which could cause deadly asphyxiation.


Obstructions and deteriorated vent systems may present serious health risk or asphyxiation.

Chemical vapor corrosion of the flue and vent system may occur if air for combustion contains certain chemical vapors. Spray can propellants, cleaning solvents, refrigerator and air conditioner refrigerants, swimming pool chemicals, calcium and sodium chloride, waxes, bleach and process chemicals are typical compounds which are potentially corrosive.

If after inspection of the vent system you found sooting or deterioration, something is wrong. Call the local gas utility to correct the problem and clean or replace the flue and venting before resuming operation of the water heater.

FLOOD DAMAGE

Flood damage to a water heater may not be readily visible or immediately detectable. However, over a period of time a flooded water heater will create dangerous conditions which can cause **DEATH, SERIOUS BODILY INJURY, OR PROPERTY DAMAGE**. Contact a qualified installer or service agency to replace a flooded water heater. Do not attempt to repair the unit! It must be replaced!

	⚠ DANGER
	Fire and Explosion Hazard <ul style="list-style-type: none">• Do not obstruct combustion air openings at the bottom of the water heater.• Do not use or store flammable vapor products such as gasoline, solvents or adhesives in the same room or area near water heater or other appliance.• Can cause serious injury or death.

INSTALLED IN SUITABLE AREA: To insure sufficient ventilation and combustion air supply, proper clearances from the water heater must be maintained. See "Facts to Consider About Location" section. Combustible materials such as clothing, cleaning materials, or flammable liquids, etc. must not be placed against or adjacent to the water heater which can cause a fire.

ANODE ROD INSPECTION

CAUTION
Property Damage Hazard
<ul style="list-style-type: none">• Avoid water heater damage.• Inspection and replacement of anode rod required.

Each water heater contains at least one anode rod, which will slowly deplete (due to electrolysis) prolonging the life of the water heater by protecting the glass-lined tank from corrosion. Adverse water quality, hotter water temperatures, high hot water usage, hydronic heating devices, and water softening methods can increase the rate of anode rod depletion. Once the anode rod is depleted, the tank will start to corrode, eventually developing a leak. Certain water conditions will cause a reaction between the anode rod and the water. The most common complaint associated with the anode rod is a "rotten egg smell" produced from the presence of hydrogen sulfide gas dissolved in the water.

Important: Do not remove this rod permanently as it will void any warranties. A special anode rod (Kit # 9006291005) may be available if water odor or discoloration occurs (see "Replacement Parts").

NOTE: The water supply system may require special filtration equipment from a water conditioning company to successfully eliminate all water odor problems. The anode rod should be inspected after 3 years of use and annually thereafter until the condition of the anode rod dictates its replacement.

NOTE: Artificially softened water requires the anode rod to be inspected annually.

The following are typical (but not all) signs of a depleted anode rod:

- The majority of the rods diameter is less than 3/8".
- Significant sections of the support wire (approx. 1/3 or more of the anode rod's length) are visible.

If the anode rod show signs of either or both it should be replaced.

NOTE: Whether re-installing or replacing the anode rod, check for any leaks and immediately correct if found.

1. Disconnect the electrical power to the water heater.
2. Close the shutoff valve on the cold-water line.
3. Follow the instructions in the "Draining The Tank" section in the Operating Manual to drain approximately 5 gallons (20 litres) of water from the tank.
4. Close the drain valve.
5. Disconnect the hot-water piping from the Hot Water Outlet Nipple/Anode.
6. Remove the Hot Water Outlet Nipple/Anode.

ANODE ROD REPLACEMENT

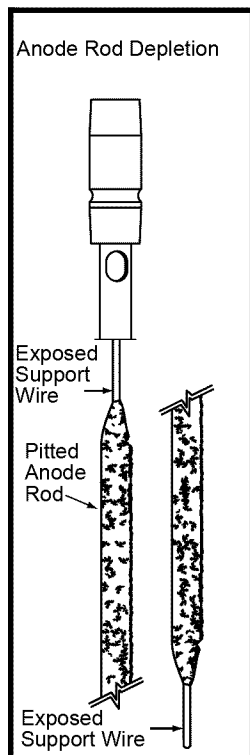


FIGURE 36

- If it is necessary to replace the anode rod, refer to the detailed instructions that are supplied with the replacement anode.
- See the "Parts Reference Illustration" for anode rod location.

- See the "Parts Reference Illustration" for anode rod location.

Else:

- Re-install the Hot Water Outlet Nipple/Anode.
- Reconnect the hot-water piping to the Hot Water Outlet Nipple/Anode.
- Open the shutoff valve on the cold-water line.
- Fill the tank following the instructions in the "Filling The Water Heater".
- Check for leaks and repair as required.
- Reconnect the electrical power to the water heater.
- Restart the water heater following the "Lighting Instructions".

TEMPERATURE-PRESSURE RELIEF VALVE OPERATION

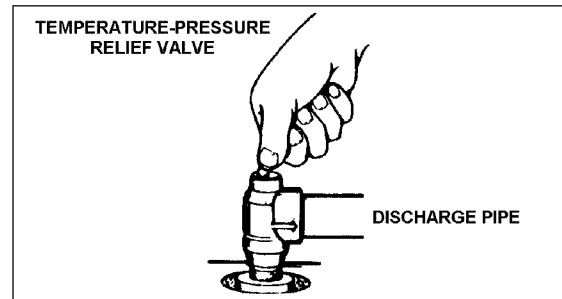
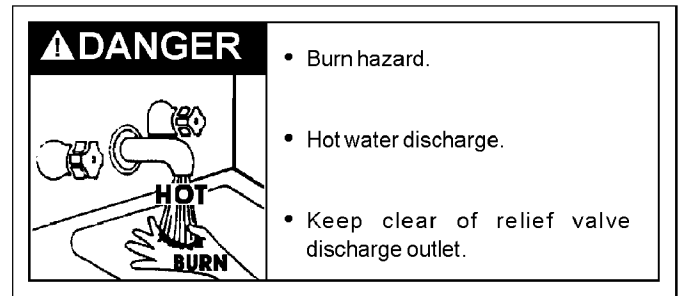


FIGURE 37

The temperature-pressure relief valve lever must be operated at least once a year to ensure that the water ways are clear. When checking the temperature-pressure relief valve operation, make sure that:

1. No one is in front of or around the outlet of the temperature-pressure relief valve discharge line.
2. The water discharge will not cause any property damage, as the water may be extremely hot.
3. A discharge line is connected to this valve, directing the flow of hot water from the valve to a proper placement for disposal.

If water does not flow freely when the lever is in the open position, replacement of the valve is required. Turn off the cold water inlet heater and call a qualified service man.

If after manually operating the valve (see Figure 37), it fails to completely reset and continues to release water, immediately close the cold water inlet to the water heater, follow the draining instructions, and replace the temperature-pressure relief valve with a new one.

If the temperature-pressure relief valve on the appliance weeps or discharges periodically, this may be due to thermal expansion. You may have a check valve installed in the water line or a water meter with a check valve. Consult your local water supplier or a qualified service agency for further information. Do not plug the temperature-pressure relief valve.

MOTORS

Motors are permanently lubricated and do not need periodic lubrication. Keep fan and motor free of dust and dirt by cleaning annually.

SNOW ACCUMULATION

Keep the area around flue terminal free of snow and ice. The appliance will not function properly if the intake air or exhaust is impeded (blocked or partially blocked) by obstructions.

CLEANING THE INLET WATER FILTER

The water inlet filter must be cleaned on a regular basis. The frequency of this cleaning is dependent on the quality of your local water supply. You will need to prepare a pan or shallow basin to collect some of the draining water. The water inlet filter is located inside the door on the left-hand side of the heat engine. To clean the inlet filter:

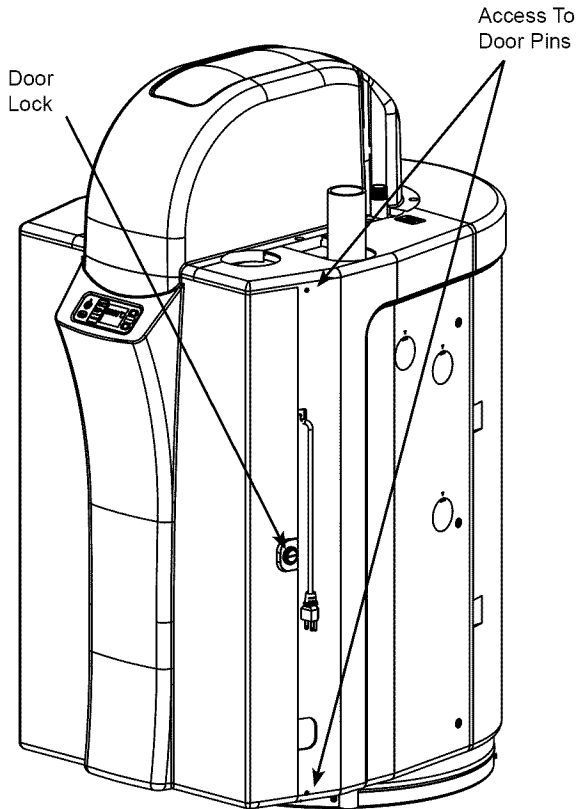


FIGURE 38

Remove the filter:

- Disconnect the electrical power to the water heater.
- Close the shutoff valve on the cold-water line.
- Unlock the door by rotating the side lock counter-clockwise with a wide, slot screwdriver.
- Pop the top and bottom door pins by pushing the pins out, using a small screwdriver. Open the door.
- Open a nearby hot water faucet for 30 to 60 seconds to depressurize the water tank.
- Put on a pair of rubber gloves and close the shut-off valve on the water inlet fitting.
- Position the basin to catch any water that could drain.
- Unscrew the filter and clean by rinsing it under a faucet and scrubbing with a brush if required.

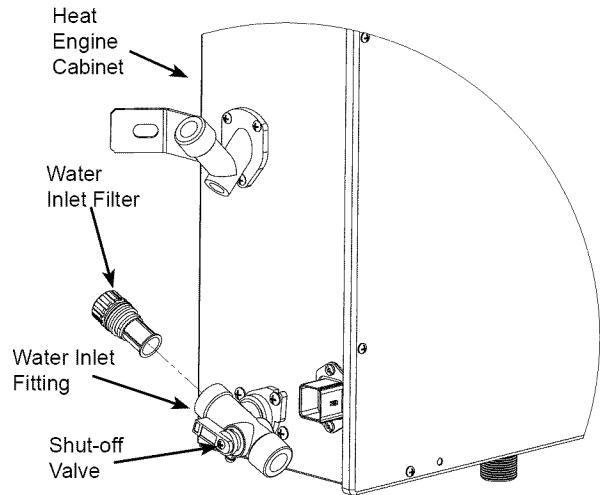


FIGURE 39

Install the filter:

- Install the clean filter.
- Open the shut-off valve on the water inlet fitting and remove the rubber gloves.
- Remove and empty the basin.
- Open the shutoff valve on the cold-water line.
- Close and lock the door.
- Reconnect the electrical power to the water heater.
- Restart the water heater following the "Lighting Instructions".

CLEANING THE HEAT ENGINE

It is imperative that the control compartment burner and circulating air passageways of the appliance is kept clean.

- Turn off and disconnect the electrical power. Allow to cool.
- Remove and clean the water inlet filter. See "Cleaning The Inlet Water Filter" section.
- Remove the front panel.
- Use a low air pressure to remove dust from the main burner, heat exchanger, and blower. Do not use a wet cloth or spray cleaners on the burners.

NOTE: Do not use volatile substances such as benzene and thinners. They may ignite or fade the paint.

FLUSHING THE HEAT EXCHANGER (LIME BUILD-UP)

The heat exchanger must be cleaned on a regular basis to reduce lime build-up. The frequency of this cleaning is dependent on the quality of your local water supply. Failure to flush the appliance will cause damage to the heat exchanger. Damage caused by lime build-up is not covered by the unit's warranty.

- Disconnect electrical power to the water heater.
- Close the shutoff valves on both the hot water and cold water lines.
- Drain the tank using the instructions in the "Draining The Tank" section.

- Disconnect the hoses joining the tank and the heat engine (upper hose is water outlet and lower hose is water inlet) at the heat engine fittings.
- Connect a length of hose (not provided) to each of the fittings. (Note: A GHT (garden hose thread) to 3/4" NPT adaptor may be required.)

5 gallon pail of virgin, food grade, white vinegar (or virgin, food grade, citric acid).

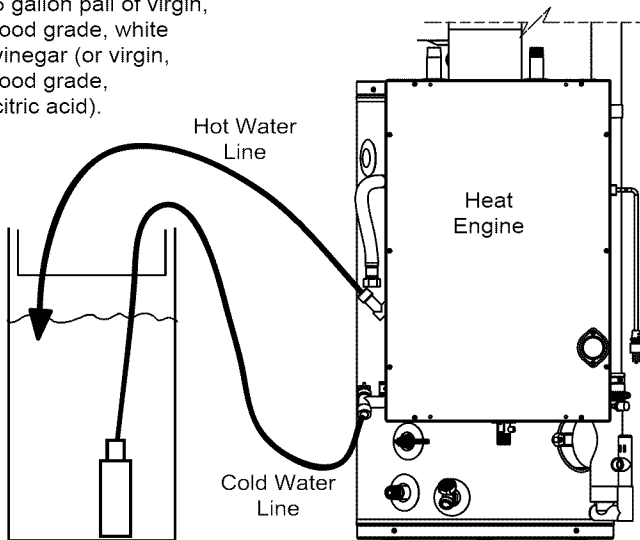


FIGURE 40

- Connect a pump to the hose running to the heat engine water inlet (lower fitting). We recommend a submersible utility pump for the circulating pump. (Note: If a submersible pump is not used, connect a hose from the circulating pump to the cleaning solution.)
- Pour approximately 4 gallons (15 litres) of virgin, food grade, white vinegar or citric acid into a 5 gallon or greater pail.
- Place the "intake" and "output" hoses into the pail of cleaning solution. If a submersible utility pump is used, place the pump into the pail of cleaning solution.
- Plug in the circulating pump.
- Connect the electrical power to the water heater and run the heat engine.
- Operate the heat engine to circulate the cleaning solution through the system for at least 45 minutes. (Note: Lower the temperature below 104°F (40°C) or to vacation mode.) Warning: cleaning solution will become hot very quickly.
- Disconnect electrical power to the water heater.
- Remove the pail of cleaning solution and replace it with a pail of clean water.
- Rinse the cleaning solution from the water heater as follows:
 - Connect the electrical power to the water heater and run the heat engine.
 - Allow the clean water to flow through the heat engine for 5 minutes.
 - Disconnect electrical power to the water heater and circulating pump.
 - Disconnect hoses from heat engine and circulating pump, draining the cleaning solution into the pail.
 - Reconnect the original hoses to the heat engine.

- Remove the in-line filter at the cold water inlet and clean out any residue. Assemble the filter back into the unit.
- Open the shutoff valves on both the hot water and cold water lines.
- Fill the tank with water.
- Connect the electrical power to the water heater.
- Restart water heater following lighting instructions.

DRAINING THE TANK

	<ul style="list-style-type: none"> • Burn hazard. • Hot water discharge. • Keep hands clear of drain valve discharge.
--	--

The water heater should be drained if being shut down during freezing temperatures. Also periodic draining and cleaning of sediment from the tank may be necessary.

1. Set the power switch to the "OFF" position.
2. OPEN a nearby hot water faucet and let the water run until it is no longer hot.
3. CLOSE the cold water inlet valve to the water heater.
4. Connect a hose to the drain valve and terminate to an adequate drain.
5. OPEN the water heater drain valve to allow for tank draining. **NOTE: If the water heater is going to be shut down and drained for an extended period, the drain valve should be left open with hose connected allowing water to terminate to an adequate drain.**
6. CLOSE the drain valve.
7. Follow instructions in the "Filling The Water Heater" section.
8. Follow the lighting instructions on the label or see "Lighting Instructions" in this manual to restart the water heater.

FAULT INDICATION AND ERROR CODES

A red fault LED (lighting a large red exclamation point) should be present on the display panel if a fault condition exists.

A history of the last 9 error codes along with the current error code is stored in memory and can be accessed via the diagnostic mode. If the current error code is zero, "E00" shall be displayed (see Table 3).

DIAGNOSTIC DISPLAY

By simultaneously pressing the “Mode” and “down arrow” buttons for 3 seconds the unit will allow access to the diagnostic mode.

In diagnostic mode, using the up/down arrow allows for cycling between diagnostic codes. The numeric display will show the diagnostic code for 1 second, followed by the actual measurement displayed for 3 seconds. For example, H01 - 105 represents the diagnostic code of “H01” and the value of “105” is the inlet water temperature measurement. The display will continue to show the diagnostic code and the measurement value unless the up or down arrows are pressed to switch to the next item (see Table 3). If no buttons are pressed for 30 seconds the unit will revert back to operation mode where the set-point temperature is displayed.

Diagnostic Code	Description	Code and Measurement Display Format	Units (Example of)	Displayed characters (Example of)	Meaning	Remarks
H01	Inlet Water Temperature	H01 – xxx	°C or °F	041 or 105	41°C or 105°F	°C LED or °F LED turned ON
H02	Heat engine outlet water temperature	H02 – xxx	°C or °F	041 or 105	41°C or 105°F	°C LED or °F LED turned ON
H03	Storage tank temperature	H03 – xxx	°C or °F	041 or 105	41°C or 105°F	°C LED or °F LED turned ON
H04	Heat engine water flow rate	H04 – xxx	litres/minute	056	5.6 litres/minute (1.48 Gallons/minute)	1 litre = 0.264 Gallons 1 gallon = 3.78 litres
H05	Fan Speed	H05 - __x – xxx	rpm	006_511	6511 rpm	rpm=rotations per minute
H06	Fan Current	H06 - __x – xxx	mA	001_456	1456 mA (1.456A)	mA=milliamperers
H07	Proportional Valve Current	H07 – xxx	mA	178	178 mA	mA=milliamperers
H08	Total Heating Time	H08 – xxx – xxx	hours	001_234	1234 hours (51.41 days)	
H09	Total Cycles	H09 – xxx – xxx	heating cycles	000_459	459 heating cycles	
H10	Heat Engine Rated Output	H10 – xxx	KBtu/hour	100	100 KBtu/hour	
H11	Current Error Code (See Fault Code Table)	H11 – xxx	N/A	E00	Proper operation - No error	
H12 – H20	Error Code History, From the Most Recent to the Least Recent (See Fault Code Table)	Hxx – xxx	N/A	E28	Ignition failure	The most recent error corresponds to H12 and the least recent to H20
H21	Software Release Number (CWHCB)	H21 – xxx – xxx	N/A	002_025	Software release number 2.25	For the main controller board
H22	Software Release Number (UIM)	H22 – xxx – xxx	N/A	002_009	Software release number 2.09	For the display board
H23	Configuration File Number	H23 – xxx – xxx	N/A	000_006	Configuration file number 6	

TABLE 3

If an error code is displayed, or odd behavior of the unit occurs, the first corrective action should be to “Cycle the Power”: Unplug the 120Vac power cord and after 5 seconds plug it in again. If this doesn’t clear the fault, proceed with the “Remedy” in the following table (Table 4). The remedies for each fault code are put in logical order, so proceed one by one, starting with #1.

If wire harness checking is required, examine the integrity of wires themselves, the connector housings, the integrity of the terminals as well as condition of the crimps.

Fault Code Displayed	Description	Cause	Lockout type	Remedy
E01, E02	Invalid Rated KBtu/Model Type.	Control detects that the configuration selected is not defined or the configuration has never been set.	Continuous	Change the Control Board.
E03, E04, E05, E06	Main Valve Relay Out Of Sequence.	Control detects that a relay used to enable the Main Valve has failed in either the open or closed position.	Soft	Change the Control Board.
E07	Flame Detected.	Flame detected when no flame was expected.	Soft	1. Check the Flame Sensor. 2. Check the flame wire harness. 3. Change the Control Board.
E08	ECO Switch is open.	Control detects that the ECO Switch is open, preventing power to the Main Valve.	Continuous	1. Check inlet water filter. 2. Measure the water temperature. ECO Switch open temperature is $85\pm 5^{\circ}\text{C}$ ($185\pm 14^{\circ}\text{F}$) and close temperature is $65\pm 5^{\circ}\text{C}$ ($149\pm 14^{\circ}\text{F}$). 3. Check the ECO Switch. 4. Check the ECO wire harness. 5. Change the Control Board.
E09	High Temperature Switch open.	Control detects that the High Temperature Switch is open, preventing power to the Main Valve.	Continuous	1. Measure the exhaust gas temperature. High Temperature Switch open temperature is $74\pm 2.8^{\circ}\text{C}$ ($165\pm 5^{\circ}\text{F}$) and close temperature is $57\pm 2.8^{\circ}\text{C}$ ($135\pm 5^{\circ}\text{F}$). 2. Check the switch. 3. Check the High Temperature Switch wire harness. 4. Change the Control Board.
E10	120Vac too high.	120Vac > Overvoltage Limit.	Auto Reset	Nominal voltage is 120Vac. Overvoltage limit is 132Vac, Undervoltage limit is 102Vac. 1. Check the power cord. 2. Check the wall outlet. 3. Measure the voltage at the board connector J7 between pin 1 and pin 3. If the voltage is between limits, change the Control Board.
E11	120Vac too low.	120Vac < Undervoltage Limit.		

TABLE 4

Fault Code Displayed	Description	Cause	Lockout type	Remedy
E12	Blower Current abnormal.	Blower Current meets requirements for a completely blocked flue.	Soft	<ol style="list-style-type: none"> 1. Check the venting system. If the venting system is clear, recalibrate the unit. 2. Check the blower wire harness. 3. Change the blower. 4. Change the Control Board.
E13		Blower Current meets requirements for a partially blocked flue.		
E14		Blower Current meets requirements for a non-heating blocked flue evaluation.		
E15	Blower speed abnormal.	Blower speed is 200RPM below the target speed for 20 seconds.	Soft	<ol style="list-style-type: none"> 1. Check the blower wire harness. 2. Change the blower. 3. Change the Control Board.
E16		Blower speed is 500RPM above the target speed for 6 seconds.		
E17		Machine starts or normal combustion, but Blower speed = 0 for 3 sec.		
E18		Have Blower's output signal but the Blower speed = 0 for 400ms.		
E19		Blower speed stuck > 3000 rpm	Soft	
E20	Proportional valve (PV) current unusual.	Proportional valve Current < Minimum.	Soft	<ol style="list-style-type: none"> 1. Check the proportional gas valve wire harness. 2. Change the Control Board. 3. Change the gas valve assembly.
E21		Proportional valve Current > Maximum.		
E22	Outlet Temperature Probe is Open circuit.	Outlet Temperature is < minimum defined temperature.	Soft	<ol style="list-style-type: none"> 1. Check temperature probes wire harness. 2. Replace temperature probe. 3. Change the Control Board.
E23	Outlet Temperature Probe is Short circuit.	Outlet Temperature is > maximum defined temperature.		
E24	Inlet Temperature Probe is Open circuit.	Inlet Temperature is < minimum defined temperature.		
E25	Inlet Temperature Probe is Short circuit.	Inlet Temperature is > maximum defined temperature.		
E26	Tank Temperature Probe is Open circuit.	Tank Temperature is < minimum defined temperature.		
E27	Tank Temperature Probe is Short circuit.	Tank Temperature is > maximum defined temperature.		

TABLE 4

Fault Code Displayed	Description	Cause	Lockout type	Remedy
E28	Ignition failure.	After a failure to detect the flame during ignition, the control will retry the specified number of times. After the maximum failed attempts, this fault is declared.	Soft	<ol style="list-style-type: none"> 1. Check the igniter wire harness. 2. Check igniter 120Vac voltage supply during the ignition time. 3. Check the ignition rod. If it looks dirty clean it using isopropyl alcohol and a clean cloth. 4. Check the high voltage wiring connection between igniter and igniter rod for proper contact.
E30	Blower Error.	Locked Rotor.	Soft	<ol style="list-style-type: none"> 1. Check the venting system. 2. Check the blower wire harness. 3. Change the blower. 4. Change the Control Board.
E33	Water Flow Valve Closed.	The water valve did not open when attempting to establish flow.	Soft	<ol style="list-style-type: none"> 1. Check the water valve wire harness. 2. Change the Control Board. 3. Change the water valve.
E34	Proportional Valve (PV) Response Too Slow.	The closed loop control of the proportional valve is not functioning properly (control error) or the valve is responding slowly (valve failure).	Soft	Check the proportional gas valve wire harness, change the Control Board, change the gas valve assembly
E35	Repeated Flame Loss Fault.	Low Gas Inlet Pressure. Low Water Flow Rate	Soft	<ol style="list-style-type: none"> 1. Clean or change the water filter. 2. Check the Flame Sensor wire harness. 3. Check line gas pressure. If it is above 5" WC check the Flame Sensor and if it looks dirty, clean it up using isopropyl alcohol and a clean cloth. 4. Change the Flame Sensor. 5. Change the Control Board.
E36	Calibration error.	Calibration sequence incomplete because end of "call-for-heat" during the calibration time, or calibration sequence not initiated because of lack of "call-for-heat", or the unit has been never calibrated or Calibration is successful but DIP switch 4 not set to "normal".	Soft	<ol style="list-style-type: none"> 1. Unplug the power cord, check the DIP switch 4 position and put it in ON position. 2. Increase the set point so that a "call-for-heat" occurs. 3. Drain the tank in order to lower the water temperature so that a "call-for-heat" is generated. 4. Set DIP switch 4 to OFF position. 5. Recalibrate the unit. 6. Change the Control Board.

TABLE 4

Fault Code Displayed	Description	Cause	Lockout type	Remedy
E37	No Water Flow.	The heater could not start because the water flow was not established. This can be caused by an air bubble or a blockage in the heat engine water passage, a failed flow sensor or a failed circulation pump.	Soft	<ol style="list-style-type: none"> 1. Check the water inlet on the heat engine. 2. Make a water draw during first 60 seconds after putting the unit in ON mode (to evacuate possible air from the heat engine water passage). 3. Check wire harness for pump, water valve and water flow sensor. 4. Check the pump 120Vac voltage supply (the pump shall be energized during the heating mode). 5. Clean or change the water filter. 6. Change Control Board. 7. Change pump. 8. Change water valve.
E99	Board Failure.	An internal diagnostic check on the board has failed.	Soft	Change the Control Board.

TABLE 4

Lockout types:

Continuous. Needs "Cycle the Power" or service to restart.

Soft. Will try to automatically recover and restart after 20 minutes.

Auto Reset. Will automatically restart when voltage returns to acceptable parameters.

TROUBLESHOOTING

These guidelines should be utilized by a qualified service agent.

Problem	Possible Cause(s)	What to do
NOT ENOUGH HOT WATER	STANDBY button turned off.	Press switch to turn heater on.
	No power at outlet.	Repair service to outlet.
	Error Code being displayed	Refer to "FAULT INDICATION AND ERROR CODES" section and Table 4 or call service agency or dealer.
	Set point set too low.	Adjust Set point higher.
	Heater undersized.	Reduce hot water use.
	Low gas pressure	Contact dealer.
	Incoming water is unusually cold.	Allow more time for heater to reheat.
	Leaking hot water pipes or fixtures.	Have plumber check and repair leaks.
CONDENSATION	Water on the floor under heater.	See CONDENSATE section.
WATER LEAKS	Improperly sealed, hot or cold supply connections, relief valve, drain valve or thermostat threads.	Check for leaks. See Figure 41.
	Leakage from other appliances or water lines.	Inspect other appliances near water heater.
	Condensation of flue products.	Refer to CONDENSATE section.
LEAKING T&P	Thermal expansion in closed water system.	Install thermal expansion tank (Do not plug T&P valve).
	Improperly sealed valve.	Check relief valve for proper operation (Do not plug T&P valve).
HOT WATER ODORS (refer to "Smelly Water" and "Anode Rod Inspection" sections)	High sulfate or mineral content in water supply.	Drain and flush heater thoroughly then refill.
	Bacteria in water supply.	Chlorinate water supply.
HOT WATER TOO HOT	Thermostat set too high.	Refer to TEMPERATURE REGULATION section.
WATER HEATER SOUNDS	Condensation dripping on burner.	Refer to CONDENSATION above.
SOOTING	Improper combustion.	Refer to Air Requirements.
BURNER WILL NOT STAY LIT-GOES OUT AFTER 4-5 SECONDS	Low Water Flow Rate	Clean or change the water filter.
	Damaged Flame Sensor (Error code E35)	Replace Flame Sensor
VENT GAS ODORS	Lack of air supply.	Shut off water heater immediately and contact a qualified service agency to determine cause.
	Improperly installed vent piping.	
	Downdraft	
	Poor Combustion	
WHEN THE TAP IS OPENED, THERE IS NO HOT WATER OR THE HOT WATER TURNS COLD AND STAYS COLD.	a. There is a problem with a single-control faucet. b. The unit display is an error code. c. Water heater disconnected from electrical power.	a. Draw water from the "hot" faucet for 1-2 minutes. b. Refer to error code list. c. Check electrical power connections.
THE WATER IS NOT HOT ENOUGH.	The temperature is set too low.	a. Check unit's temperature setting. b. Check for cross plumbing between cold and hot water lines.
THE WATER IS TOO HOT.	The temperature set too high.	Check unit's temperature setting.

TABLE 5

Problem	Possible Cause(s)	What to do
CANNOT OPEN DOOR.	Door pins locked in place.	a. Ensure the door lock is unlocked b. Ensure the top and bottom door pins are released by using a small screwdriver to pry the pins in the direction of the door opening.

TABLE 5

SERVICE

If a condition persists or you are uncertain about the operation of the water heater, contact Sears Product Repair Services at 1-800-4-MY-HOME (1-800-469-4663).

LEAKAGE CHECKPOINTS

Use this guide to check a "Leaking" water heater. Many suspected "Leakers" are not leaking tanks. Often the source of the water can be found and corrected.

If you are not thoroughly familiar with gas codes, your water heater, and safety practices, contact your gas supplier or qualified installer to check the water heater.

Read this manual first. Then before checking the water heater make sure the gas supply has been turned "OFF", and never turn the gas "ON" before the tank is completely full of water.

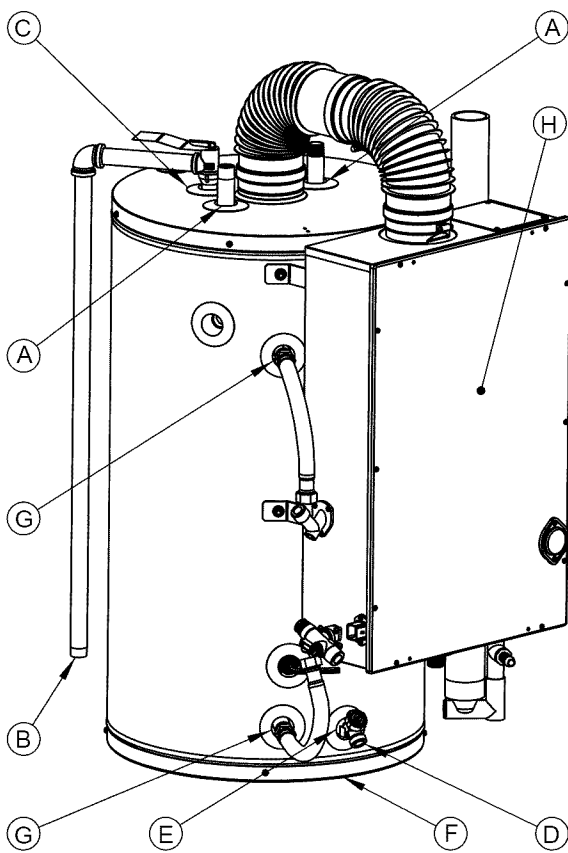
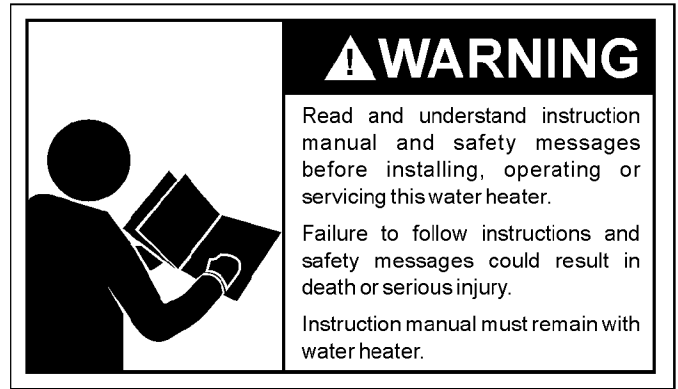


FIGURE 41



Never use this water heater unless it is completely filled with water. To prevent damage to the tank, the tank must be filled with water. Water must flow from the hot water faucet before turning "ON" gas to the water heater.

- A. *Condensation may be seen on pipes in humid weather or pipe connections may be leaking.
- B. Small amounts of water from temperature-pressure relief valve may be due to thermal expansion or high water pressure in your area.
- C. *The temperature-pressure relief valve may be leaking at the tank fitting.
- D. Water from a drain valve may be due to the valve being slightly opened.
- E. *The drain valve may be leaking at the tank fitting.
- F. Water in the water heater bottom or on the floor may be from condensation, loose connections, or the relief valve. DO NOT replace the water heater until a full inspection of all possible water sources is made and necessary corrective steps taken.
- G. *The hose from the tank to the heat engine may be leaking at the tank fitting.
- H. *The fittings at the circulation pump may be leaking.

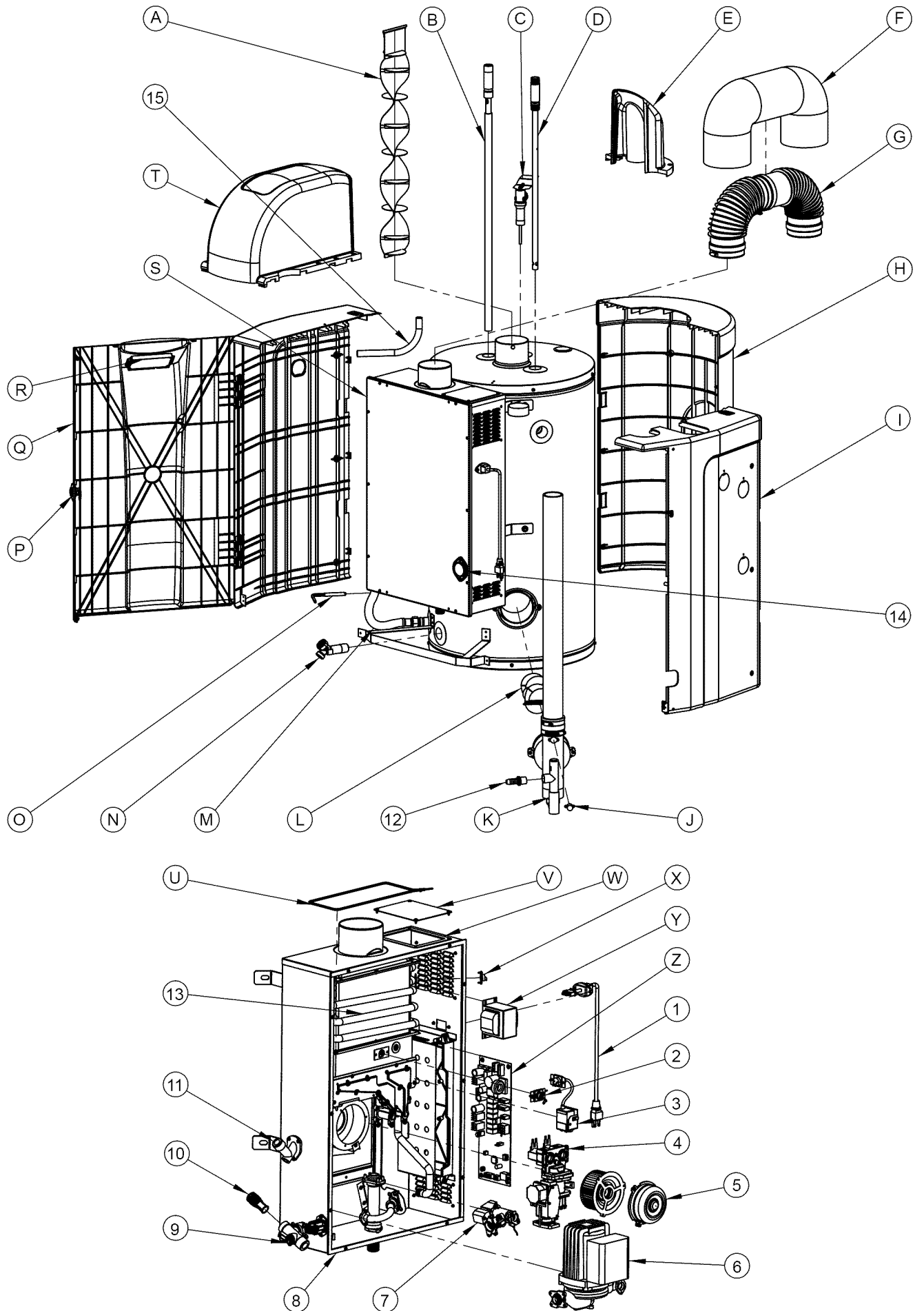
Leakage from other appliances, water lines, or ground seepage should also be checked.

- * To check where threaded portions enter the tank, insert cotton swab between jacket opening and fitting. If cotton is wet, follow "Draining The Tank" section instructions in the "Maintenance" section and then remove fitting. Put pipe dope or teflon tape on the threads and replace. Then follow the instructions in "Filling the Water Heater" section.

REPLACEMENT PARTS

ITEM #	DESCRIPTION	153.331010	153.331000 HA
		KIT #	KIT #
2	Flame sensor (w/ bracket and gasket)	9007428015	9007428015
3	Ignitor (w/ spark generator, bracket and gasket)	9007429015	9007429015
4	Gas valve	9007207005	9007207005
5	Blower motor assembly	9007430005	9007430005
6	Circulation pump assembly	9007173005	9007173005
7	Water valve assembly	9007424005	9007424005
10	Inlet water filter	9007971005	9007971005
13	Heat exchanger	9007577005	9007577005
15	Diptube J 3/4" (return)	9007208005	9007208005
B	Anode/AL/NIP/HT (w/ Hot water outlet nipple)	9006291005	9006291005
B	Anode/MG/NIP/HT (w/ Hot water outlet nipple)	9004333005	9004333005
B	Anode/KA-90/NIP/HT (w/ Hot water outlet nipple)	9008027005	9008027005
C	T&P relief valve	9003741005	9003741005
D	NIP/DIP/TBO/HT (w/ Cold water inlet nipple)	9007178005	9007178005
J	High Temperature Switch	9007211015	9007211015
K	Drain/trap assembly-condensate	9007205005	9007205005
M	12" Hose (braided)	9007176005	9007176005
N	Drain valve	9000058015	9000058015
O	Tank thermistor (probe)	9007177005	9007177005
R	Display subassembly (w/ Bilingual label) (English/French)	9007426005	9007426005
R	Display subassembly (w/ English label)	9007425005	9007425005
S	Heat engine assembly	9007206005	9008028005
U	High-Limit Fuse	9007210015	9007210015
X	ECO Switch	9007179015	9007179015
Y	Transformer	9007209005	9007209005
Z	Control board assembly (PCB assembly w/ base) (0 - 3,500 ft (0 - 1,067 m))	9007175005	N/A
Z	Control board assembly (PCB assembly w/ base) (3,501 - 6,500 ft (1,067 - 1,981m))	N/A	9007439005
Z	Control board assembly (PCB assembly w/ base) (6,501 - 8,500 ft (1,981 - 2,591m))	9007440005	9007440005
Z	Control board assembly (PCB assembly w/ base) (8,501 - 11,000 ft (2,591 - 3,352m))	9007441005	9007441005
*	Inlet/outlet thermistor (Temp sensor)*	9007174005	9007174005
*	PCB fuse*	9007427015	9007427015
*	Transformer fuse*	9007431015	9007431015

* Not shown in exploded view.



PARTS IDENTIFICATION

ITEM #	DESCRIPTION
A	Baffle, Flue
B	Anode/MG/NIP/HT (w/ Hot water outlet nipple)
C	T&P relief valve
D	NIP/DIP/TBO/HT (w/ Cold water inlet nipple)
E	Cover, Back-flue gas return
F	Top insulation
G	Flue gas return duct assembly
H	Shroud, back-tank assembly
I	Shroud, right side-tank assembly
J	High Temperature Switch
K	Drain/trap assembly-condensate
L	Baffle, Exhaust
M	12" Hose (braided)
N	Drain valve
O	Tank thermistor (probe)
P	Front door lock (Hook cam)
Q	Shroud, right side-tank assembly & door
R	Display subassembly
S	Heat engine assy
T	Cover, front-flue gas return
U	High-Limit Fuse
V	Air inlet cover (Direct vent)
W	Air inlet cover gasket (Direct vent)
X	ECO Switch
Y	Transformer
Z	Control board assembly (w/ Base)
1	Power cord assembly
2	Flame sensor
3	Ignitor (spark generator)
4	Gas valve
5	Blower motor assembly
6	Circulation pump assembly
7	Water valve assembly
8	Front cover gasket
9	Water inlet fitting
10	Inlet water filter
11	Return fitting (flange)
12	Barbed fitting
13	Heat exchanger
14	Service cap
15	Diptube J 3/4" (return)

NOTES

NOTES

Get it fixed, at your home or ours!

Your Home

For troubleshooting, product manuals and expert advice:



www.managemylife.com

For repair – **in your home** – of **all** major brand appliances, lawn and garden equipment, or heating and cooling systems, **no matter who made it, no matter who sold it!**

For the replacement parts, accessories and owner's manuals that you need to do-it-yourself.

For Sears professional installation of home appliances and items like garage door openers and water heaters.

1-800-4-MY-HOME[®] (1-800-469-4663)

Call anytime, day or night (U.S.A. and Canada)

www.sears.com www.sears.ca

Our Home

For repair of carry-in items like vacuums, lawn equipment, and electronics, call anytime for the location of your nearest

Sears Parts & Repair Service Center

1-800-488-1222 (U.S.A.) **1-800-469-4663** (Canada)

www.sears.com www.sears.ca

To purchase a protection agreement on a product serviced by Sears:

1-800-827-6655 (U.S.A.) **1-800-361-6665** (Canada)

Para pedir servicio de reparación a domicilio, y para ordenar piezas:

1-888-SU-HOGAR[®]

(1-888-784-6427)

www.sears.com

Au Canada pour service en français:

1-800-LE-FOYER^{MC}

(1-800-533-6937)

www.sears.ca

The Sears logo, featuring the word "Sears" in a large, stylized, serif font with a shadow effect.