

SEARS**USE & CARE
MANUAL****STOCK NO.
89969****KNOW YOUR UNIT**

Read this booklet so you will be able to enjoy all the features in your Kenmore Micro/Convection Oven.

Record in space provided below the Model No. and the Serial No. found on the label on the inner left side of control panel.

Model No. _____

Serial No. _____

Retain this information for future reference.

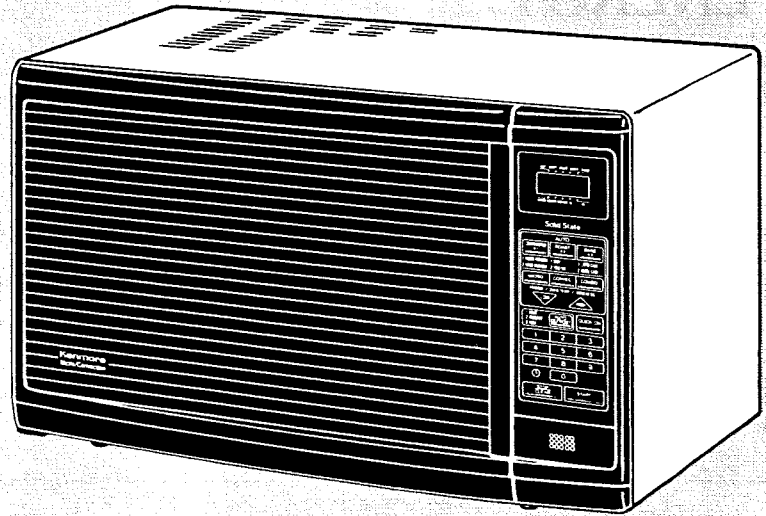
**Kenmore[®]****MICRO/CONVECTION
OVEN****Use and Care**

YOUR SAFETY FIRST

The Sears Kenmore Microwave/Convection Oven, though simple to use, is not a toy. Respect it as an electric cooking appliance. Become familiar with microwave energy, its uses and limitations.

PRECAUTIONS TO AVOID POSSIBLE EXPOSURE TO EXCESSIVE MICROWAVE ENERGY

- (a) DO NOT ATTEMPT to operate this oven with the door open since open-door operation can result in harmful exposure to microwave energy. It is important not to defeat or tamper with the safety interlocks.
- (b) DO NOT PLACE any object between the oven front face and the door or allow soil or cleaner residue to accumulate on sealing surfaces.
- (c) DO NOT OPERATE the oven if it is damaged. It is particularly important that the oven door close properly and that there is no damage to the:
 - (1) DOOR (bent)
 - (2) HINGES AND LATCHES (broken or loosened)
 - (3) DOOR SEALS AND SEALING SURFACES
- (d) THE OVEN SHOULD NOT BE ADJUSTED OR REPAIRED BY ANYONE EXCEPT PROPERLY QUALIFIED SERVICE PERSONNEL.

IMPORTANT-FOR PROPER AND SAFE USE OF YOUR OVEN

- **The oven should not be run without the metal turntable and turntable roller rest in place.**
- Food must be placed on the center of the metal turntable.
- When a browning dish is used, the browning dish bottom must be at least 3/16in. above metal turntable. Carefully read and follow the instructions for the browning dish.
- The oven should be thoroughly checked by a trained service technician, should it be dropped or damaged, before it is operated again.
- The oven has several built-in safety switches to make sure the power remains off when the door is open. DO NOT try to defeat these switches.
- Before using for the first time, operate the oven without food on convection cooking mode for 20 minutes at 450°F. This will allow the oil that is used for rust protection to be burned off.
- When cooking popcorn, follow popcorn package directions and see "Questions and Answers" found on page 21.
- When heating packaged microwave foods, always place them on a microwave proof dish. For example, microwave french fries.

DON'TS

- DO NOT attempt to operate this oven with the door open.
- DO NOT run the oven empty without food in it.
- DO NOT use metal baking pan for microwave or micro/convection combination cooking.
- DO NOT store burnable material, such as food, in your microwave/convection oven.
- DO NOT heat any types of baby bottles or baby food. Uneven heating may occur and possibly cause personal injury.
- DO NOT heat small-necked containers, such as syrup bottles, in the microwave oven.
- DO NOT deep-fat fry in your microwave. This is not a safe procedure in the confined cavity.
- DO NOT attempt to do home canning in your microwave. It is impossible to be sure all areas of the jar have reached boiling temperature for the proper processing time.
- DO NOT use this microwave/convection oven for commercial purposes. This Sears Kenmore Microwave/Convection Oven is made for household use only.

IMPORTANT SAFETY INSTRUCTIONS

When using electrical appliances basic safety precautions should be followed, including the following:

WARNING – To reduce the risk of burns, electric shock, fire, injury to persons or exposure to excessive microwave energy:

1. Read all instructions before using the appliance.
2. Read and follow the specific "PRECAUTIONS TO AVOID POSSIBLE EXPOSURE TO EXCESSIVE MICROWAVE ENERGY" found on page 2.
3. As with most cooking appliances, close supervision is necessary to reduce the risk of a fire in the oven cavity.
NOTE: If a fire should start:
 - * KEEP THE OVEN DOOR CLOSED
 - * TURN THE OVEN OFF
 - * AND DISCONNECT THE POWER CORD OR SHUT OFF POWER AT THE FUSE OR CIRCUIT BREAKER PANEL.
 - a. Do NOT grossly overcook foods. As many grossly overcooked foods will cause fires in the oven cavity, carefully attend the oven; especially, if paper, plastic, or other combustibles are placed inside the oven.
 - b. Do NOT use the cavity for storage purposes. Do not store cooking utensils, or combustible items such as paper products, bread, cookies, etc. inside the oven because if lightning strikes the power lines it may cause the oven to turn ON.
 - c. Do NOT use wire twist-ties in the oven. Be sure to inspect purchased items for wire twist-ties and remove them before the item is placed in the oven.
4. This appliance must be grounded. Connect only to properly grounded outlet. See "GROUNDING INSTRUCTIONS" found on page 5.
5. Install or locate this appliance only in accordance with the provided installation instructions.
6. Some products such as whole eggs, water with oil or fat, sealed containers and closed glass jars for example may explode and should not be heated in this oven.

7. Use this appliance only for its intended use as described in this manual. Do not use corrosive chemicals or vapors in this appliance. This type of oven is specifically designed to heat or cook food. It is not designed for industrial or laboratory use.
8. As with any appliance, close supervision is necessary when used by children.
9. Do not operate this appliance if it has a damaged cord or plug, if it is not working properly or if it has been damaged or dropped.
10. This appliance should be serviced only by qualified service personnel. Contact nearest authorized service facility for examination, repair or adjustment.
11. Do not cover or block any openings on the appliance.
12. Do not store or use this appliance outdoors. Do not use this product near water — for example, near a kitchen sink, in a wet basement, or near a swimming pool, and the like.
13. Do not immerse cord or plug in water.
14. Keep cord away from heated surfaces.
15. Do not let cord hang over edge of table or counter.
16. When cleaning surfaces of door and oven that comes together on closing the door, use only mild, non-abrasive soaps or detergents applied with a sponge or soft cloth. (See "Care and Cleaning" instructions on page 22.)
17. Do not use paper products when appliance is operated in the convection or micro/convection combination mode.
18. Do not store any materials, other than manufacturer's recommended accessories, in this oven when not in use.
19. Do not cover racks or any other part of the oven with metal foil. This will cause overheating of the oven.

SAVE THESE INSTRUCTIONS

SAFETY CERTIFICATION

The Sears Kenmore Microwave/Convection Oven is designed and thoroughly tested to meet exacting safety standards. It meets UL and FCC requirements and complies with safety performance standards of the U.S. Department of Health and Human Services.

TABLE OF CONTENTS

General Instructions

■ Location of Model Number Label	4
■ IMPORTANT-Electrical Grounding Instructions	5
■ Installation	5
■ Setting "Time of Day"	5
■ Names of Oven Parts	6
■ Oven Control Panel	7

User Instructions

■ Recall and Change of Settings	8
■ Regular Timer	8
■ Child Lock-Out	8

Detailed Directions

■ <u>Microwave Cooking</u>	8-12
● Quick-Start Cooking	8-9
● "Hi-Power"/"Multi-Power" Cooking	10
● Cooking Guide for Multi-Power Settings/Wattage of Output Power	10
● Automatic Defrosting	11
● Multi-Stage Cooking	12
■ <u>Convection Cooking</u>	13-19
● Convection Cooking with Automatic Preheat	14
● Micro/Convection Combination Cooking	15
● Automatic Cooking	16-18
● Convenience	16
● Roast	17
● Bake	18
● Multi-Stage Cooking	19
Specifications/Wattage/Cavity Size	19
Questions and Answers	20-21
Care and Cleaning	22
Oven Utensils Guide	22
Before Calling for Service	23
Sears Service	23
Sears Warranty	Back Cover

SEARS KENMORE MICROWAVE/CONVECTION OVEN USE AND CARE MANUAL- MICROWAVE/CONVECTION OVEN USE INSTRUCTIONS

Advice on the use and care of Sears appliances is always available at your nearest Sears store. When seeking information, be sure you have the complete model number which is located on the plastic label. See below for its location.

MODEL NUMBER

To make a request for service, information or replacement of parts, Sears will require the complete model number of your microwave/convection oven. The number is on the inner left side of the control panel. (You must open the door to see the number).

The number will look like this: 564.8000000.

* KENMORE is a registered trademark of Sears, Roebuck and Co..

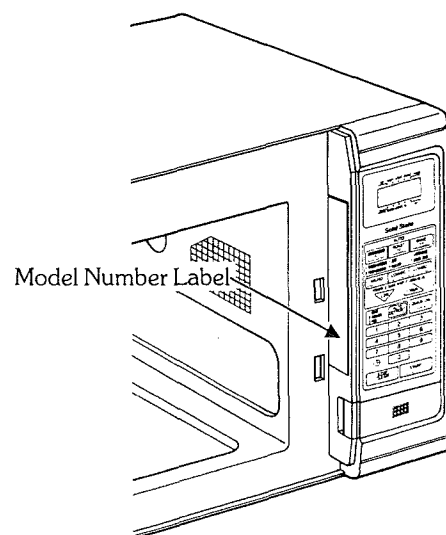

IMPORTANT – ELECTRICAL GROUNDING INSTRUCTIONS

This appliance must be grounded. In the event of an electrical short circuit, grounding reduces the risk of electric shock by providing an escape wire for the electric current. This appliance is equipped with a cord having a grounding wire with a grounding plug. The plug must be plugged into an outlet that is properly installed and grounded.

WARNING – Improper use of the grounding plug can result in a risk of electric shock.

Consult a qualified electrician or Sears Service Department if the grounding instructions are not completely understood, or if doubt exists as to whether the appliance is properly grounded.

A short power-supply cord is provided to reduce the risks resulting from becoming entangled in or tripping over a longer cord.

Longer cord sets or extension cords are available and may be used if care is exercised in their use.

If a long cord or extension cord is used, (1) the marked electrical rating of the cord set or extension cord should be at least as great as the electrical rating of the appliance*, (2) the extension cord must be a grounding-type 3 wire cord, and (3) the longer cord should be arranged so that it will not drape over the countertop or tabletop where it can be pulled on by children or tripped over accidentally. The electrical power cord must be kept dry and must not be pinched or crushed in any way.

***NOTE:** This oven draws a 13.5-ampere electrical current on 120 volts.

PROPERLY POLARIZED AND GROUNDED OUTLET

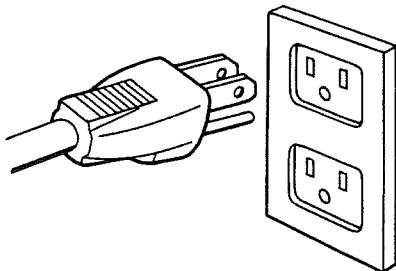

Three-Pronged (Grounding) Plug

INSTALLATION

Install your oven by following these four simple steps:

Step 1: Remove all packing material and accessories.

Step 2: Place the oven in the level location of your choice, but make sure there is at least 4 inches of space on the top of the oven and 5 inches of space on the both sides of the oven for proper ventilation.

Top of the oven should be kept clear and the plastic feet must be kept on the oven so there is air flow ventilation. The exhaust vents are at the top of the oven. **“DO NOT place any objects such as books, papers, or cooking accessories over the top of the exhaust vents.” Blocking the vents can damage the oven.**

Step 3: Plug your oven into a Standard 120 volt/60 Hz household outlet. Be sure the electrical circuits is at least 15 amperes and that your microwave/convection oven is the only appliance on the circuit.

Step 4: When your microwave/convection oven is plugged in for the first time or when power resumes after a power interruption, the numbers in the display window will show “0:00” plus the hours and minutes that have elapsed since the oven was plugged in or the power was restored. This means that the TIME OF DAY clock must be set. Refer to “Setting Time of Day” below.

NOTE: If your oven does not operate properly, unplug the oven from the 120 volt/60 Hz household outlet and then plug it back in.

This unit is not designed for 50 Hz or any circuit other than a 120 volt/60 Hz AC circuit.

This oven is not designed for a built-in use.

Allow 4 inches of space on the top of the oven and 5 inches of space on both sides of oven.

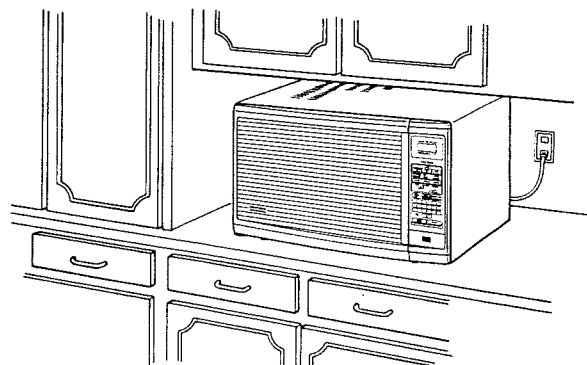

SETTING TIME OF DAY

- Touch STOP/CLEAR.
- Touch “⌚” TIME OF DAY PAD.
- Touch numbers indicating the correct time.
- Touch “⌚” TIME OF DAY PAD.

NAMES OF OVEN PARTS

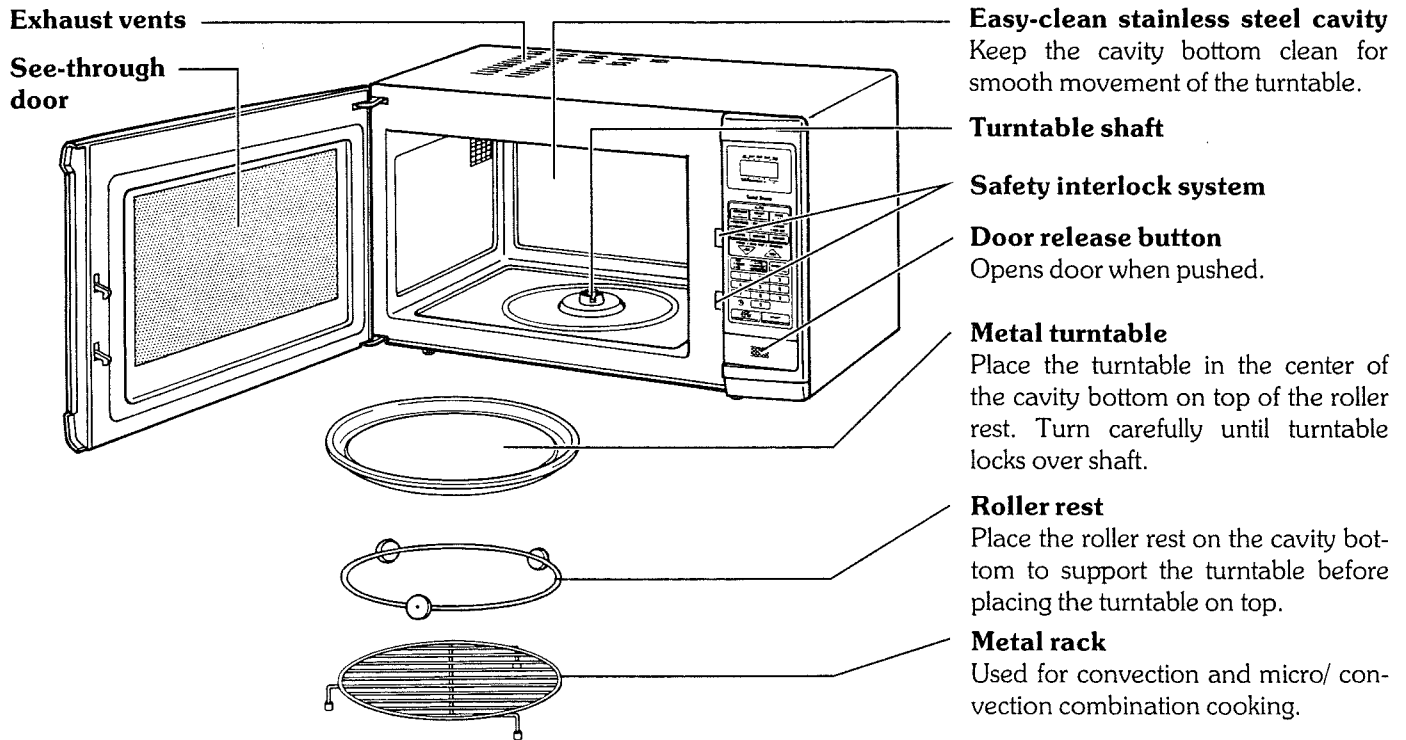

Remove your Sears Kenmore Microwave/Convection Oven and all items from the shipping carton. Your oven will be packed with the following items:

Metal Turntable	1 each
Roller Rest	1 each
Metal Rack	1 each
Use & Care Manual	1 each
Cookbook	1 each
"Easy Use Chart" Card	1 each

Metal Turntable

1. Place metal turntable on roller rest securely. **Do not operate the oven without the metal turntable.**
2. Only use the metal turntable specifically designed for this oven. Do not substitute any other metal turntable.
3. If metal turntable is hot, allow to cool before cleaning or placing in water.
4. Metal turntable can turn in either direction.
5. If food or utensil on metal turntable touches oven walls causing the turntable to stop moving, the turntable will automatically rotate in opposite direction. This is normal.
6. Do not cook directly on metal turntable when performing microwave cooking. Always place food in a microproof dish, or on a rack set in a microproof dish. For micro/convection combination cooking, place meats and poultry on a microproof and heatproof rack set in a microproof and heatproof dish. Place dish on metal turntable.

Metal Rack

1. The metal rack may get hot during cooking. Pot holders may be needed to remove rack after cooking.
2. Do not use browning dishes on metal rack.
3. To prevent magnetron failure:
 - Do not use foil or metal containers directly on the metal rack when using the microwave or micro/convection combination cooking.
 - Do not place the metal rack directly on the floor of the oven. Always place rack on the turntable.

OVEN CONTROL PANEL

Indicator Lights — Micro, Combo, Convec and Auto Defrost lights indicate which cooking operation is being used.

Display Window — Used to show:

- Time of Day
- Cooking Time
- Microwave Cooking Power Level
- Oven Temperature
- Auto Cook (A1-1 – A3-2)
- Auto Defrost (dEF1,dEF2,dEF3)
- Weight of Food (pound,ounce)
- Doneness (H, L)
- End, PAUS (Pause)

It also functions as countdown timer or temperature indicator when cooking.

Micro — Used in setting Microwave Cooking mode.

Convec — Used in setting Convection Cooking mode.

Auto Defrost Selection — Used in setting Auto Defrost feature.

Time of Day Pad — Used in setting Time of Day and Child Lock-Out.

Stop/Clear — Used to stop oven during cooking and clear all entries except Time of Day.

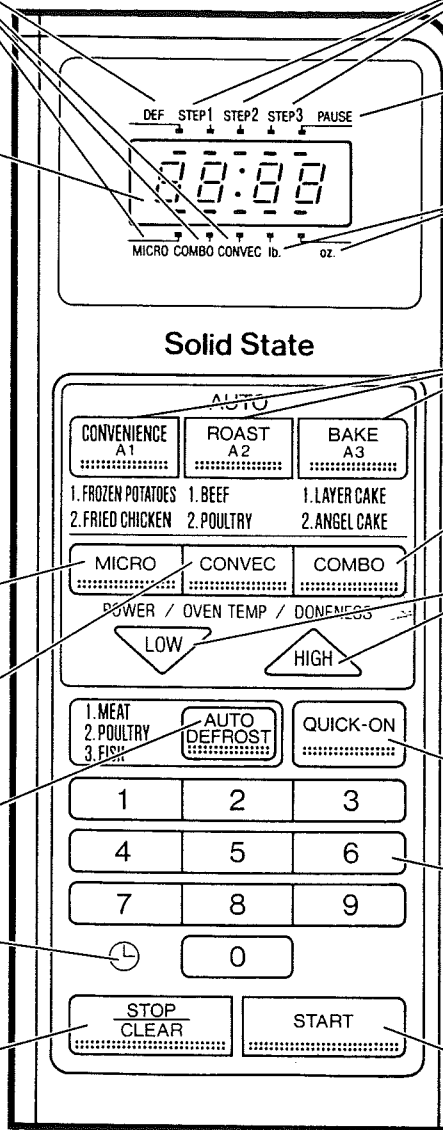

Step Lights — When cooking stages are set, lights will go on indicating the stage in which your oven is cooking.

Pause Light — Shows oven will pause between the stages in Auto Defrost and Auto Cook.

Weight Lights — When Convenience, Roast or Auto Defrost is set, light will flash to let you know to enter the weight of the food.

Auto Cook — Used in setting Auto Cook feature.

Combo — Used in setting Micro/Convection Combination Cooking mode.

Low/High Pads — Used to select Doneness (Auto Cook), power levels (Microwave Cooking), and temperature (Convection and Micro/Convection Combination Cooking).

Quick On — Used in setting quick start cooking at HI Power.

Numbers — Used to enter the Time of Day, Cooking Times, Recipe Number of Auto Course, and Weight of Food.

Start — Starts the Oven.

NOTE: A “beep” tone sounds when a “pad” on the control panel is touched, to indicate a setting has been entered.

RECALL AND CHANGE OF SETTINGS

To recall (check) a setting while the oven is operating, follow the directions below.

- To recall TIME OF DAY while the oven is running, touch “⊖” PAD. It will show momentarily in the display window.
- To check the cooking power level during microwave cooking, touch MICRO.
- To check the oven temperature during convection or micro/convection combination cooking, touch the pad that indicates which cooking operation is being used.

To change a setting, follow the directions below.

- To change a setting BEFORE you start the oven, touch STOP/CLEAR once and reset your desired sequence. To clear AFTER you have started the oven, touch STOP/CLEAR twice and reset desired sequence.

REGULAR TIMER

Your oven also has a timer that can be used for non-cooking functions. When used as a regular timer, the oven is not running. The timer is simply counting down in seconds.

For detailed instructions on using this timer, see below.

To use the Regular Timer feature:

1. Touch STOP/CLEAR.
2. Touch MICRO.
3. Continue holding “” PAD until “P 0” appears in display window.
4. Touch the numbers for the amount of time desired.
5. Touch START. The time will begin counting down in the display window with no cooking or heating in the oven. A tone will sound and the word “End” will show in the display window for 2 seconds when the time is over.

CHILD LOCK-OUT

Your oven has a “Child Lock-Out” feature to prevent a playful or accidental running of the oven by a child.

After this feature is set, the display will return to the Time of Day.

The oven cannot be programmed to cook even though the pads for a cooking function may be touched accidentally after this feature is set. The display window will show “E”. To correct, touch STOP/CLEAR then the display window will return to the Time of Day.

For setting this Child Lock-Out feature, see below.

To set:

1. Touch STOP/CLEAR.
2. Touch “⊖” TIME OF DAY PAD.
3. Touch “9” four times.
4. Touch START.
(Time of Day will return to the display window.)

To cancel:

1. Touch STOP/CLEAR.
2. Touch “⊖” TIME OF DAY PAD.
3. Touch “7” four times.
4. Touch START.
(Time of Day will return to the display window.)

QUICK-START COOKING (HI-power only)

This feature was designed for simple setting of the oven with convenience cooking and/or reheating in mind. To set, simply touch the “QUICK-ON” pad, and touch a number pad from 1 to 9. The oven starts instantly.

1. Touch STOP/CLEAR. Place food in oven, then close the door.



2. Touch QUICK-ON.

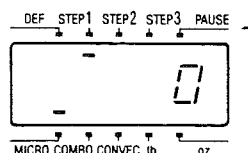
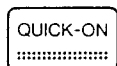

3. Touch a number (single digit, 1 – 9) for desired

cooking time in minutes.

The oven will begin to cook on HI-power.

EXAMPLE: To set 1 minute, touch “1.”

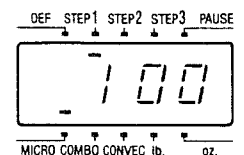
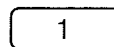

NOTE: To stir or rearrange food during cooking, simply open the door; stir or rearrange and close the door.

Touch “START”.

The oven will automatically continue to count down the remaining amount of time left in the display window.

QUICK-START REHEATING GUIDE

This guide shows the food items and some special notes for reheating with "Quick-start" feature.

Food	Amount	Time	Special Notes
BEVERAGES			
Water Based	1 cup	1-2 min	Heat uncovered. Use 6 to 8-ounce cup.
	2 cups	3-4 min	
Milk Based	1 cup	2 min	
	2 cups	3 min	
Broth-based soups	10 ³ / ₄ -oz. can	3-4 min	Use 1½-quart casserole. Cover.
Cream-based soups	10 ³ / ₄ -oz. can	4-5 min	Use 1½-quart casserole. Cover.
Sandwich	1-2	1 min	Place on paper plate or towels.
Cooked pizza, 10 inches cut in 8 portions	2 wedges 4 wedges whole	2 min 2-3 min 4-5 min	Place on paper towels or paper plate or leave in uncovered cardboard box, points toward center.
Casseroles	1 qt. (4 cups)	5-7 min	Cover. Stir once.
MEAT			
Sliced thin	3-5 oz.	1 min	Heat on microproof plate, covered with waxed paper.
Sliced thick	½"-1" thick	2 min	Place in microproof dish. Cover. Stir halfway through cooking time.
Barbecued beef, chili, stews, hash, etc.	16-oz. can	4-5 min	
Hamburgers, Meat loaf slices, Sausage patties	1 serving 2 servings 4 servings	1 min 2-3 min 4-5 min	Place on microproof plate. Cover with paper towel. Turn over once.
POULTRY			
Chicken pieces	1	1 min	Heat on microproof plate. Cover with waxed paper. If fried, cover with paper towel.
	2	1-2 min	
	4	2-3 min	
	6	4-6 min	
Creamed chicken	10½-oz. can	3-4 min	Cover. Stir once.
Chicken, turkey, sliced	3-5 oz.	1-2 min	Heat on microproof plate. Cover with waxed paper.
SEAFOOD			
Shrimp, crab, or scallops in sauce, frozen	6½ oz.	4-6 min	Pierce pouch and place on microproof plate. Flex pouch to mix halfway through cooking time.
Seafood or fish casseroles, frozen	16 oz.	5-7 min	Remove from package to 1-quart microproof casserole. Cover. Stir once during cooking.
SIDE DISHES			
Rice, Pasta	¾ cup	1 min	Heat in microproof casserole, covered tightly with plastic wrap.
	1-2 cups	2 min	
Vegetables, frozen in pouch	10-12 oz.	5-8 min	Pierce pouch. Place on microproof plate. Flex halfway through cooking time to mix.
Mashed potatoes, instant	4 servings (3½-oz. packet)	5-7 min	Follow package directions. Reduce liquid by 1 tablespoon.
Canned vegetables	8 oz.	1-2 min	Use 4-cup microproof casserole, covered. Stir once.
	15 oz.	2-3 min	
	17 oz.	3-4 min	
Pudding and pie filling mix	¾ oz.	6-7 min	Follow package directions. Stir once. Use 4-cup glass measure.

“HI-POWER”/“MULTI-POWER” COOKING

“HI” gives the highest cooking power possible with your oven. It is the recommended setting for cooking foods with high moisture content or for cooking foods that need fast cooking to maintain their natural flavor and texture. Many foods need slower cooking (at less than full power) in order to give you the best results. In addition to “HI” there are ten multi-power settings. The cookbook tells you which power setting is recommended for the food being cooked.

1. Touch STOP/CLEAR. Place food in oven, then close the door.



2. Touch MICRO.

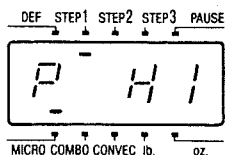
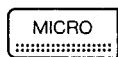

3. Touch “” PAD for desired cooking power level.
EXAMPLE: To set power level 80, touch “” PAD twice.

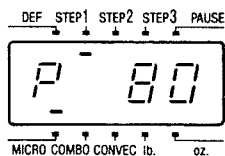
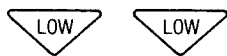

NOTE: When using the LOW/HIGH PADS to change power levels you can touch them once, or twice, etc., or you can touch and hold the pad. The display window will show the power levels changing automatically.

It is not necessary to touch “” PAD when cooking with the highest power (“HI”). To set “HI-POWER” cooking, skip step 3 above.

4. Touch numbers for desired cooking time.
EXAMPLE: To set 3-1/2 minutes, touch “3”, “3” and “0.”

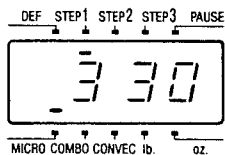
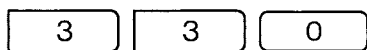

Remember, the timer is a digital clock that is divided into 60 seconds. Therefore, 1/2 minute is equal to 30 seconds. Touch 30 and not 50 (as with a calculator) to indicate 1/2.

NOTE: Although we recommend entering the power level first when setting the microwave oven, you can enter the time first and then enter the power level.

5. Touch START.



COOKING GUIDE FOR “MULTI-POWER” SETTINGS

The “Multi-Power” feature lets you cook at the best power level for the food being cooked.

POWER LEVEL	POWER SETTINGS	EXAMPLES	MICROWAVE OUTPUT POWER*
10	WARM	● Softening cream cheese	180 watts
20	LOW	● Softening chocolate ● Heating breads, rolls, tacos	250 watts
30	DEFROST	● Thawing meat, poultry, and seafood ● Completing the cooking cycle of casseroles, stews, and some sauces	320 watts
40	BRAISE	● Cooking less tender cuts of meat in liquid or slow cooking dishes	390 watts
50	SIMMER	● Cooking stews and soups after bringing to a boil	465 watts
60	BAKE	● Cooking scrambled eggs	535 watts
70	ROAST	● Cooking rump roast, ham, veal, and lamb	605 watts
80	REHEAT	● Reheating precooked or prepared food quickly	675 watts
90	SAUTÉ	● Cooking onions, celery and green peppers quickly	745 watts
100 (HI)	MAX POWER	● Cooking poultry, fish, vegetables, and most casseroles ● Preheating the browning dish; boiling water	815 watts

*Approximate watts as measured by IEC-705 Test Procedure.

FAST DEFROST

Your oven is equipped with an Auto Defrost system which is the best defrost method for this oven.

FAST DEFROST is explained in order to show other defrosting possibilities.

To speed up the defrosting of dense food items over 1 lb., start on “HI” then reduce to the 30 (DEFROST) setting.

1. Microwave on “HI” for 1-2 minutes per pound of dense food items.
2. Then Microwave on 30 (DEFROST) for 3 minutes per pound or until food is thawed. Defrosting time will be greatly reduced.

AUTOMATIC DEFROSTING

Three automatic defrosting courses are preset in the oven. The "Auto Defrost" feature provides you with the best defrosting method for most frozen foods. Refer to cookbook for detailed instructions.

1. Touch STOP/CLEAR. Place food in oven, then close the door.



2. Touch AUTO DEFROST.

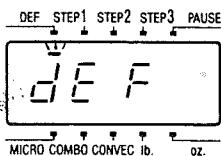

3. Touch number (single digit 1-3) to select the appropriate defrosting course.

EXAMPLE: To select MEAT, touch "1."

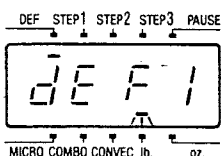
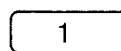

4. Enter the weight of your food in decimal increments from 0.1 pounds to 12.9 pounds.

EXAMPLE: To set 2 pounds, touch "2" and then "0."

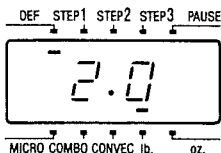

Remember to convert ounces to tenths of a pound. For example, to defrost 2 pounds 8 ounces, touch number keys "2" and "5" for 2.5 pounds.

NOTE: It is not necessary to enter the food weight when defrosting one pound of food. Unless changed, the Auto Defrost feature is automatically set for one pound.

5. Touch START.



6. At the pause, follow the cookbook instructions for separating, rearranging, covering and turning over.

NOTE: If the oven door is not opened during the pause time segment, the oven will restart automatically after 5 minutes. Because turning, separating, etc. are usually necessary for proper defrosting and cooking, follow steps 1 thru 7 for best results.

7. After turning over, separating the food, etc., touch START.

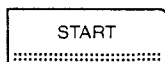

AUTO DEFROST COURSE CHART

COURSE #	FOOD	BASE Q'TY	DEFROST TIME PER BASE Q'TY	AMOUNT
DEFROST 1 (DEF 1) MEAT	BEEF, LAMB, PORK, VEAL, VARIETY MEAT	1 lb	9 min.	0.1 to 3.2 lbs.
			13 min.	3.3 to 9.9 lbs.
DEFROST 2 (DEF 2) POULTRY	CHICKEN, CORNISH HENS, DUCKLING, TURKEY	1 lb	14-1/4 min.	0.1 to 6.7 lbs.
			9-1/4 min.	6.8 to 12.9 lbs.
DEFROST 3 (DEF 3) FISH	FISH, SEAFOOD	1 lb	13-1/2 min.	0.1 to 9.9 lbs.

AUTO DEFROST INSTRUCTIONS

- The benefit of the Auto Defrost feature is automatic setting and control of defrosting, but just like conventional defrosting, you must check the food during the defrosting time.
To check the food "Pause" is preset in the Auto Defrost cycle.
Turn over, separate or rearrange food items per cookbook instructions when the word "PAUS" appears in the display window.
- For best results, remove fish/seafood/meat/poultry from its original paper or plastic packaging (wrapper). Otherwise, the packaging will hold steam and juices close to the food which can cause the outer surface of the food to cook.
- When it is difficult to remove the wrap from the food, defrost the wrapped food for about a quarter of the total defrost time. The total defrost time will be displayed at the beginning of the defrost cycle. Remove the food from the oven and remove the wrap from the food.
- Place food in a shallow microproof baking dish or microwave roasting rack to catch drippings.
- Food should still be somewhat icy in the center when removed from the oven.
- Standing time is included in the Auto Defrost courses.

IMPORTANT NOTE: The defrost power setting (power level 30 DEFROST) should not be confused with this "Auto Defrost" feature. The defrost cooking level is a low-energy setting used to cook foods that need slow, gentle cooking. Also use the defrost cooking level to thaw small ground beef patties, bacon and bread items.

MULTI-STAGE COOKING

Multi-stage cooking allows you to set the oven to cook in one stage at a certain power level for a chosen time and then in a second and a third stage at a different power level for a chosen time.

First Stage (30 minutes, Power level "HI")

1. Touch STOP/CLEAR. Place food in oven, then close the door.



2. Touch MICRO.

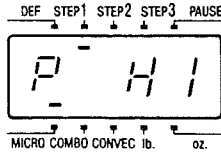

3. Set 30 minutes by touching "3" then "0" three times.

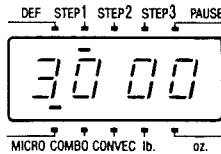
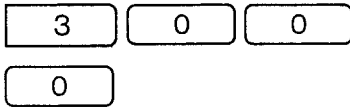

The first stage has been set.

Second Stage (60 minutes, Power level 50 "SIMMER")

4. Touch MICRO.

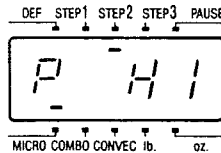

5. To set power level 50, touch and HOLD "LOW" PAD until "P 50" appears in the display window.

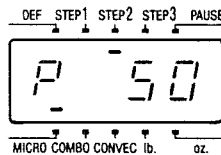

6. To set 60 minutes, touch "6" then "0" three times.

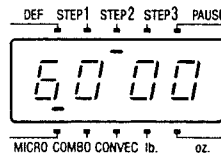
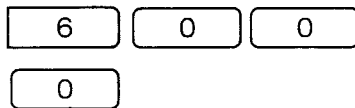

The second stage has been set.

Third Stage (15 minutes, Power level 20 "LOW")

7. Touch MICRO.

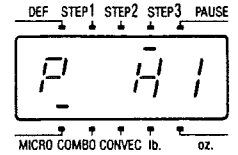

8. To set power level 20, touch and HOLD "LOW" PAD until "P 20" appears in the display window.

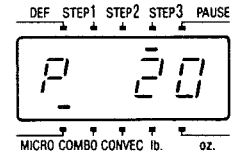

9. To set 15 minutes, touch "1", "5" then "0" twice.

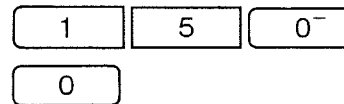

The third stage has been set.

10. Touch START for three stage cooking.



MULTI-STAGE COOKING WITH AUTO DEFROST

If you want to cook after using the Auto Defrost cycle, first set the Auto Defrost, then follow the instructions above numbered 2-10. The cooking process can be set for up to four stages when Auto Defrost is set as the first stage.

CONVECTION COOKING

The convection cooking will be best used for items like soufflés, breads, pizza, and also for meat and fish.

No special techniques are required to adapt your favorite oven recipes to convection cooking. Because convection cooking has increased efficiency due to the fan-circulated hot air, you may need to decrease conventional cooking temperatures by 25°F. This is the only difference between conventional and convection cooking.

When baking cakes, cookies, breads, rolls or other baked foods, most recipes call for preheating. Preheat the empty oven just as you do the conventional oven. However, heavier dense foods such as meats, casseroles, poultry can be started without preheating.

All heatproof cookware or metal utensils may be used in convection cooking.

Since various foods benefit from the use of the rack in addition to the turntable, we have made recommendations below. The foods listed can be placed directly on the metal rack with a heatproof plate placed below to catch the drippings.

Metal Turntable	Beef Roast, Leg of Lamb, Whole Chicken, Pie, Biscuits, Cookies, Soufflé
Metal Rack (on turntable)	Steak, Hamburger Patty, Pork Chops, Chicken Pieces

Metal Turntable

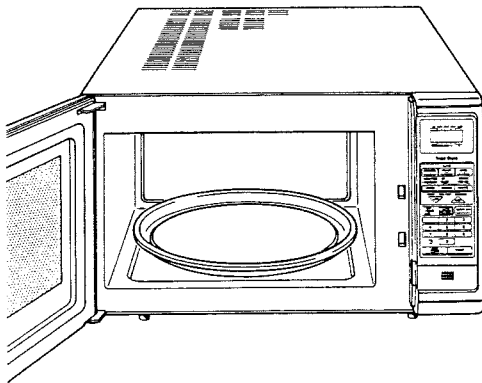

Metal Rack (on turntable)

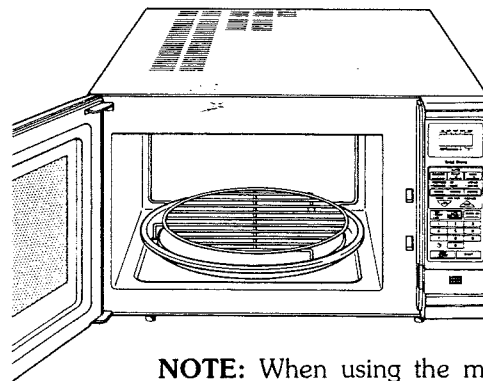

NOTE: When using the metal rack always place the rack on the turntable.

BAKING PAN/METAL UTENSILS

Any Pizza Pan with less than a 12-inch diameter can be used with this oven.

METAL UTENSILS should only be used in convection cooking. Metal utensils should be placed on the metal turntable or metal rack. Never use metal utensils for microwave or micro/convection combination cooking.

CONVECTION COOKING WITH AUTOMATIC PREHEAT



An Automatic preheating temperature of 350°F for convection cooking has been preset into the oven. Other temperatures can be set in 25 degree increments.

To use Automatic Preheat

1. Touch STOP/CLEAR.
2. Touch CONVEC.
3. Touch START.

The oven will automatically start preheating to 350°F.*

To set a temperature different than 350°F.

1. Touch STOP/CLEAR.
2. Touch CONVEC.
3. Touch “” or “” PAD to select desired temperature.
4. Touch START.*

EXAMPLE: To preheat the oven to 400°F and to set cooking time.

1. Touch STOP/CLEAR.



2. Touch CONVEC.

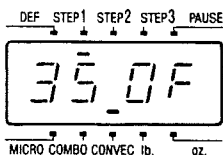

3. Touch “” PAD twice or touch and HOLD until 400F appears in the display window.

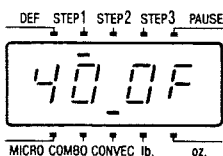

4. Touch CONVEC.



5. Set the convection cooking time by touching the corresponding numbers.

EXAMPLE: To set 45 minutes, touch “4”, “5”, and “0” twice.

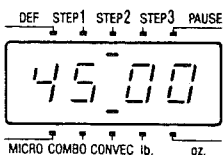
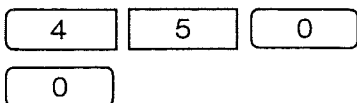

The temperature selected in the preheat stage (first stage) will be maintained in the convection cooking stage (second stage). However, if a third stage is used and a temperature other than 350°F is desired, the oven temperature must be set for this third stage.

6. Touch START.*



After the oven reaches the preheat temperature a “beep” tone will sound. The oven is now preheated.

7. Open oven door. “PAUS” appears in display window. Place food in oven. Close door. Touch START again.

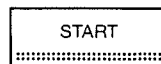



TIPS

- Place the food inside the preheated oven quickly. If the door is open left too long, the heated air will escape and the temperature will drop.
- When preheating is completed, a pulsating “beep” tone will sound until oven door is opened or 30 minutes have elapsed.
- Use pot holders whenever removing food, turntable, rack, etc. from the oven.

WARNING: The temperature in the oven is quite high.

Always use pot holders. Never remove items from oven or touch walls, turntable, etc. with bare hands.

- **REMEMBER:** The oven temperature of 350°F is preset into the oven. It is not necessary to touch “” or “” PAD unless a different oven temperature is desired.

* While the oven preheats, the temperature appears in the display window in 25°F increments. Until the oven temperature reaches 225°F, the display window shows 200F.

MICRO/CONVECTION COMBINATION COOKING

With the Micro/Convection Combination, cooking is done by both microwave and hot air, this combination cooking provides you with the speed of microwaving and the browning capabilities of convection cooking.

To use Micro/Convection Combination Cooking:

1. Touch STOP/CLEAR.



2. Touch COMBO.

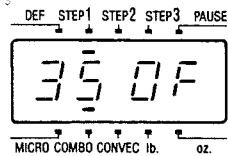
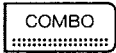

3. Set the desired oven temperature, if different than the preset 350°F.

EXAMPLE: To set 275°F, touch and HOLD " " PAD until 275F appears in display window.

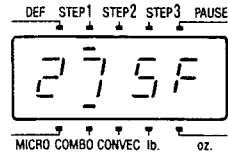

4. Set the desired cooking time by touching the corresponding numbers.

EXAMPLE: To set 16 minutes and 30 seconds, touch numbers "1", "6", "3" and "0."

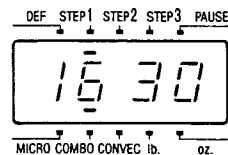
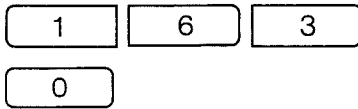

5. Touch START.





NOTE: If you wish to preheat the oven for Micro/Convection Combination Cooking, follow the steps given in the EXAMPLE for preheating and convection cooking on page 14 (1 – 3). For step 4 touch COMBO. Set the combination cooking time the same as you would for the convection cooking time. Touch START.

TIPS

- Place the food inside the preheated oven quickly. While the door is left open, the heated air will escape and the temperature will drop.
- Use pot holders whenever removing food, turntable, rack, etc. from the oven.

WARNING: The temperature in the oven is quite high.

Always use pot holders. Never remove items from oven or touch walls, turntable, etc. with bare hands.

- **REMEMBER:** The oven temperature of 350°F is preset into the oven. It is not necessary to touch " " or " " PAD unless a different oven temperature is desired.

AUTOMATIC COOKING

The oven contains 3 preset courses: CONVENIENCE, ROAST and BAKE. Each course has 2 recipes preset into the oven for cooking, roasting or baking in these categories. The times, temperatures and power levels for these recipes cannot be changed. However, “” and “” PADS can be used to control doneness of a particular recipe. For the CONVENIENCE and ROAST courses, the weight of the food needs to be entered.

CONVENIENCE

Foods and instructions for use with this feature are listed in the Convenience Course Chart below.

CONVENIENCE COURSE CHART

RECIPE #	FOOD	SPECIAL NOTES	AMOUNT
RECIPE 1 FROZEN POTATOES	French Fries, Tater Tots, Potato Patties	Place on metal pizza baking pan.	1 to 24 oz.
	Crinkle Cut French Fries	Place on metal pizza baking pan. Use HIGH “” Doneness setting.	
RECIPE 2 FRIED CHICKEN	Frozen Fried Chicken, regular-size pieces and snack-size pieces (nuggets, chunks, patties, “wingettes”, etc.)	Place on metal pizza baking pan or 9-inch baking dish. For unusually large regular-size pieces, use HIGH “” Doneness setting.	1 to 24 oz.

To use a recipe in the Convenience Course, follow these steps:

1. Touch STOP/CLEAR.



2. Touch CONVENIENCE. “A1” appears in the display window.

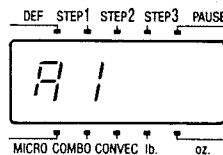

3. Touch number for recipe desired.

EXAMPLE: To heat Frozen Fried Chicken, touch “2.” “A1-2” appears in the display window and the light above “oz.” will flash.

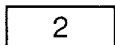

4. Enter the weight of the food.

EXAMPLE: To enter 12 ounces, touch “1” then “2.” “12” will appear in the display window and the light above “oz.” will stop flashing and remain on.

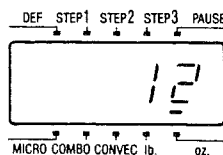

REMEMBER: Convert pounds to ounces.

EXAMPLE: 1 pound equals 16 ounces, 1-1/2 pounds equals 24 ounces.

5. If you want to select your favorite doneness, touch the “” or “” PAD. This will decrease or increase the time, as indicated.

EXAMPLE: For very large size pieces of Fried Chicken, touch “.” “H” appears in the display window.

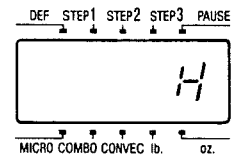

NOTE: Medium doneness is set automatically, unless you touch the “” or “” PAD.

6. Touch START.



AUTOMATIC COOKING (Continued)

ROAST

Foods and instructions for use with this feature are listed in the Roast Course Chart below.

ROAST COURSE CHART

RECIPE #	FOOD	SELECT PADS	AT PAUSE	SPECIAL NOTES	STANDING TIME
RECIPE 1 BEEF	BEEF Rib, Rump, Tenderloin Rare Medium Well-done	LOW NO HIGH	Turn over.	Use a microproof and heatproof roasting rack.	10-20 min.
RECIPE 2 POULTRY	CHICKEN Whole, 2-4 lbs.	NO	Turn over.	Place chicken breast-side down on microproof and heatproof roasting rack.	10-20 min.
	Pieces	NO	Turn over.	Use metal rack. Use a microproof and heatproof dish with trivet. Start skin-side down.	
	CORNISH HENS	NO	Turn over.	Place hens breast-side down on microproof and heatproof roasting rack.	5-10 min.
	DUCKLING	Whole, 4-6 lbs.	NO	Turn over.	Place duckling breast-side down on microproof and heatproof roasting rack.
TURKEY	Whole, over 8 lbs.	NO	Turn over.	Place turkey breast-side down on microproof and heatproof roasting rack.	10-20 min.
	Breast, 3-4 lbs.	HIGH	Turn over.	Place turkey skin-side down on microproof and heatproof roasting rack.	10-20 min.
	Parts	HIGH	Turn over.	Use metal rack. Use a microproof and heatproof dish with trivet. Start skin-side down.	5-10 min.

NOTE: For BEEF, minimum weight is 1 lb., maximum weight is 5.9 lbs.
For POULTRY, minimum weight is 1 lb., maximum weight is 12.9 lbs.

To use a recipe in the Roast Course, follow these steps:

1. Touch STOP/CLEAR.

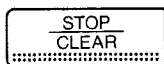

2. Touch ROAST. "A2" will appear in the display window.

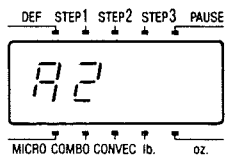
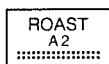

3. Touch number for recipe desired.

EXAMPLE: To cook Beef touch "1." "A2-1" appears in display window and the light above "lb." will flash.

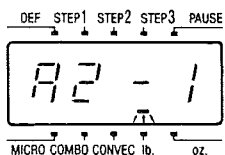
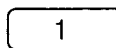

4. Enter the weight of the food.

EXAMPLE: To enter 4-1/2 pounds, touch "4" and then "5." "4.5" appears in display window and the light above "lb." will stop flashing and remain on.

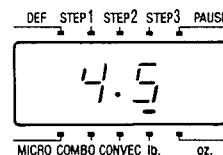
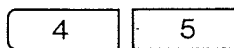

5. To select rare or well-done, touch "LOW" or "HIGH" PAD.

EXAMPLE: For rare beef, touch "LOW." "L" appears in display window.

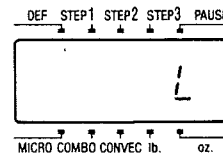

NOTE: Medium doneness is set automatically unless you touch the "LOW" or "HIGH" PAD.

6. Touch START.

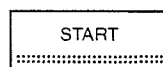





IMPORTANT: Only tenths of a pound can be entered so 1.75 lbs. would be entered as 1.8 lbs. Whole pounds are shown to the left of the decimal point, tenths of a pound are shown to the right of the decimal point.

AUTOMATIC COOKING (Continued)

BAKE

Foods and instructions for use with this feature are listed in the Bake Course Chart below.

BAKE COURSE CHART

RECIPE #	COURSE FOODS		SPECIAL NOTES
RECIPE 1 LAYER CAKE	LAYER CAKE	Layer cake mixes: yellow, white, chocolate, flavored, etc.	Follow package directions. Do one layer at a time. Use turntable. Use 8 or 9-inch metal or glass cake pan. The LOW “  ” or HIGH “  ” PAD can be used to decrease or increase bake time.
RECIPE 2 ANGEL CAKE	ANGEL FOOD CAKE	Angel Food Cake mix, regular or flavored.	Follow package directions. Use turntable. Use 10-inch tube pan.
	BUNDT*CAKE (12-cup BUNDT*pan)	Use cake mix especially for 12-cup BUNDT* pan or follow recipe on layer cake package for 12-cup BUNDT* pan.	Follow package directions. Use turntable. Use metal 12-cup BUNDT* cake pan**. For microproof/heatproof 12-cup BUNDT* pan, use HIGH “  ” doneness setting. The LOW “  ” or HIGH “  ” PAD can be used to decrease or increase bake time.

* BUNDT is a Registered Trademark of Northland Aluminum Products, Inc., Minneapolis, Minnesota, USA.

** Place a microproof and heatproof dish or plate between metal BUNDT* pan and turntable.

To use a recipe in the Bake Course, follow these steps:

1. Touch STOP/CLEAR.



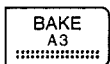

2. Touch BAKE. “A3” appears in display window.



3. Touch number for recipe desired.

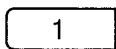

EXAMPLE: To cook a layer cake, touch “1.” “A3-1” appears in display window.

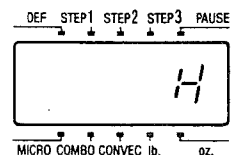

4. If you need to select doneness, touch “” or “” PAD.

EXAMPLE: To bake a BUNDT* cake with microproof/heatproof 12-cup BUNDT* pan, touch “” PAD. “H” appears in display window.



NOTE: Medium doneness is set automatically, unless you touch the “” or “” PAD.

5. Touch START.



MULTI-STAGE COOKING

In three-stage cooking, different modes of cooking can be combined for sequential cooking. For example, to bake a casserole, preheating is the 1st stage, Convection Cooking is the 2nd stage and Micro/Convection Combination Cooking is the 3rd stage.

First Stage

1. Touch STOP/CLEAR.

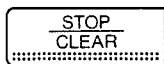

2. Touch CONVEC.

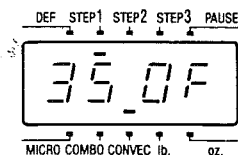

NOTE: Since the oven temperature is 350°F in this case, the temperature need not be entered since this temperature is preset in the oven.

Second Stage

3. Touch CONVEC.



4. Set the desired time for 2nd stage cooking.
EXAMPLE: Enter 25 minutes, by touching numbers “2”, “5”, “0” and “0.” “2500” will show in the display window.

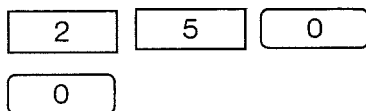

Third Stage

5. Touch COMBO.

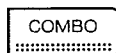

6. Set the desired time for 3rd stage cooking.

EXAMPLE: Enter 6 minutes, by touching numbers “6”, “0” and “0.” “600” will show in the display window.

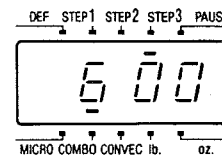
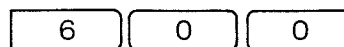

NOTE: During convection cooking, the oven keeps the same temperature in second stage as for preheating. If, however, the third stage is used, and a temperature other than 350°F is desired, the oven temperature must be set in third stage.

7. Touch START.



When the temperature reaches 350°F, “350F” shows in the display window and a “beep” tone will sound to indicate that the preheating time is over.

8. The “beep” sound stops when the door is opened. Place the food in the oven and close the door quickly. The word “PAUS” flashes in the display window.

9. Touch START.



The 25 minutes will now count down and the next stage will start automatically.

IMPORTANT: Since oven gets hot during cooking, use pot holders to remove food, turntable, rack, etc. from oven cavity.

SPECIFICATIONS

POWER SOURCE	: 120V/60Hz only
POWER CONSUMPTION	: Microwave 1550W, Convection 1550W
OUTPUT POWER	: Microwave 815W (IEC-705 Test Procedure), Convection 1500W
OUTER DIMENSIONS	: 23-1/2" (W) × 18-1/8" (D) × 15-3/16" (H)
CAVITY DIMENSIONS	: 15-3/4" (W) × 15-1/8" (D) × 9-7/16" (H)
CAVITY VOLUME	: 1.3 Cu.Ft.
NET WEIGHT	: 55 lbs.

NOTE: This oven is made for use only in U.S.A.

QUESTIONS AND ANSWERS

OPERATION

Q. What is wrong when the oven light will not glow during cooking or when the oven door is open?

A. *There may be several reasons why the oven light will not glow. Perhaps:*

- *Door is not closed and locked. Push door firmly to be sure that door is locked properly.*
 - *The light bulb has burned out.*
-

Q. Why does steam come out of the air exhaust vent?

A. *Steam is normally produced during cooking. The microwave/convection oven has been designed to vent this steam out of the top vent.*

Q. Why does the oven not work or stop during cooking?

A. *Objects that block the exhaust vents cause the oven thermostat to shut off the oven power until the interior components have cooled.*

DO NOT PLACE ANY OBJECTS SUCH AS BOOKS, PAPER, OR COOKING ACCESSORIES OVER THE TOP OF THE EXHAUST VENTS.

Q. Will the microwave oven be damaged if it operates empty?

A. *Yes. Never run it empty or without the metal turntable for microwave or micro/convection combination cooking.*

Q. Does microwave energy pass through the viewing screen in the door?

A. *No. The metal screen bounces the energy back into the oven cavity. The holes (or ports) are made to allow light to pass through. They do not let microwave energy pass through.*

Q. Why does smoke come out of the exhaust vent at the top of the oven?

A. *It is normal for smoke to come out of the vent during convection cooking.*

Also smoke can be produced when food is over-cooked. The smoke will then come out through the vent.

Keeping the oven clean will reduce smoking during convection cooking.

Q. Why does it sometimes take so long to preheat?

A. *When the oven door is opened during preheating, hot air will escape from the oven and the oven temperature will drop, making the preheating time longer. Avoid opening the oven door during preheating, convection cooking or micro/convection combination cooking, whenever possible.*

Q. Is the moisture accumulation on the top and/or sides of the oven door normal when cooking using the micro/convection combination method?

A. *Yes, when foods with high moisture content are cooked, water beads may form on the top and/or sides of the oven door, but will dissipate after use.*

Q. Why does my oven show time counting down in the display window but no cooking is occurring?

A. *The microcomputer in your oven has caused this. Simply unplug the oven and then plug it back in.*

Q. When the oven is plugged into a wall outlet for the first time, it might not work properly. What is wrong?

A. *Only when the oven is plugged in for the first time or when power resumes after a power interruption, the microcomputer used in the oven control assembly may temporarily become scrambled and fail to function as programmed.*

Unplug the oven from the 120-volt household outlet and then plug it back in. The microcomputer will be reset for proper function thereafter.

Q. Why does the turntable sometimes rotate clockwise or counterclockwise?

A. *The turntable will rotate clockwise or counterclockwise. This is normal.*

If the food or utensil on the turntable touches oven walls, causing the turntable to stop moving, the turntable will automatically rotate in opposite direction.

Q. Why is there noise coming from the turntable when the oven is turned on?

A. *This noise occurs when the roller rest and oven bottom are dirty.*

Frequent cleaning of these parts should eliminate or reduce the noise.

QUESTIONS AND ANSWERS (Continued)

FOODS

Q. What is wrong when baked foods have a hard, dry, brown spot?

A. A hard, dry, brown spot shows overcooking. Shorten the cooking or reheating time.

Q. Why do eggs sometimes pop?

A. When baking, frying or poaching eggs, the yolk may pop due to steam build-up inside the yolk membrane. To prevent this, simply pierce the yolk with a toothpick before cooking it.

CAUTION: Never cook eggs in the shell.

Q. Why are scrambled eggs sometimes a little dry after cooking?

A. Eggs dry out if they are overcooked. Though the same recipe is used each time, one may need to vary the cooking time for one of these reasons:

- Eggs vary in size.
 - Eggs are at room temperature one time and at refrigerator temperature another time.
 - The shapes of utensils vary, thereby making it necessary to vary the cooking time.
 - Eggs continue cooking during standing time.
-

Q. Is it possible to pop corn in a microwave oven?

A. Yes, if using one of the two methods described below.

- (1) Microwave-popping devices designed specifically for this type of microwave cooking or
- (2) Prepackaged commercial microwave popcorn that contains specific times and power outputs needed for an acceptable final product.

NOTE: In this method, pop prepackaged commercial microwave popcorn on the metal rack. We recommend cooking popcorn of 3.5 oz. bag size for three minutes or less. Packaged popcorn cooked over three minutes may show darkened areas inside the bag. For other popcorn bag sizes, follow popcorn package directions. **DO NOT POP DIRECTLY ON THE METAL TURNTABLE TO AVOID POOR COOKING.**

FOLLOW EXACT DIRECTIONS GIVEN BY EACH MANUFACTURER FOR THEIR POPCORN POPPING PRODUCT AND DO NOT LEAVE THE OVEN UNATTENDED WHILE THE CORN IS BEING POPPED.

IF CORN FAILS TO POP AFTER THE SUGGESTED TIMES, DISCONTINUE COOKING.

OVERCOOKING COULD RESULT IN AN OVEN FIRE.

CAUTION: NEVER USE A BROWN PAPER BAG FOR POPPING CORN.

Q. What is wrong when three potatoes bake thoroughly and the fourth one is still not cooked?

A. The fourth potato may be slightly heavier than the others and should be cooked 30 to 60 seconds longer.

Remember to allow space around each potato when baking. Also, for more even cooking, put potatoes in a circle.

Q. Why do baked apples sometimes burst during cooking?

A. The peeling has not been removed from the top half of each apple to allow for expansion of the interior of the apple during cooking. As in regular cooking methods, the interior of the apple expands during the cooking process.

Q. How are boil-overs avoided?

A. When cooking foods that tend to boil over, use a larger utensil than usual for cooking. If you open the oven door or touch STOP/CLEAR, the food will stop boiling. (Remember to touch START again after closing the door to restart the cooking cycle.)

Q. Why is a standing time recommended after microwave cooking is over?

A. Standing time allows foods to continue cooking evenly throughout for a few moments after the actual microwave oven cooking cycle. The amount of standing time depends upon the density of the food.

Q. Why is an additional time required for cooking food stored in refrigerator?

A. As in conventional cooking, the initial temperature of food affects total cooking time. More time is needed to cook food just taken out of a refrigerator versus food at a room temperature.

CARE AND CLEANING

- The oven should be turned off and cooled before cleaning.
- The oven cavity is made of stainless steel and should be cleaned with a detergent such as fantastik®, Soft Scrub® or MR. Clean®. After convection cooking in particular, the interior of the oven may be stained with spattered oil. It is recommended that the oven be cleaned each time after use before the oil spatters harden and become difficult to remove. Do not use rough or scratchy pads or cleaners.
- For best performance and safety, the inner door panel and the oven front frame should be free of food or grease build-up. Wipe both often with a mild detergent. Then rinse and wipe dry. **Never use rough powders or pads.**
- If the control panel becomes wet, clean with a soft dry cloth. Do not use harsh detergents or abrasives on control panel. Avoid the use of excess water. When cleaning the control panel, leave oven door open to prevent oven from accidentally turning on. After cleaning the control panel, touch STOP/CLEAR. This will clear any entries that might have been entered accidentally while cleaning the panel.

REMOVABLE PARTS

- It is occasionally necessary to remove the metal turntable for cleaning. Wipe up spillovers with paper towel or cloth before removal of the metal turntable.
NOTE: When metal turntable is removed for cleaning, water or food particles should not be allowed to spill into the opening in the center of the oven bottom.
- Metal turntable and metal rack should be washed in warm water with a mild detergent and a soft cloth. Once they are clean, rinse well, and dry with a soft cloth. Never use rough cleaning powders, steel wool or rough cleaning pads.
NOTE: Cool metal turntable and metal rack completely before washing.
- The roller rest and oven cavity bottom should be cleaned regularly to avoid excessive noise. Simply wipe the oven bottom surface with mild detergent water and dry. The roller rest may be washed in warm water with a mild detergent and a soft cloth.

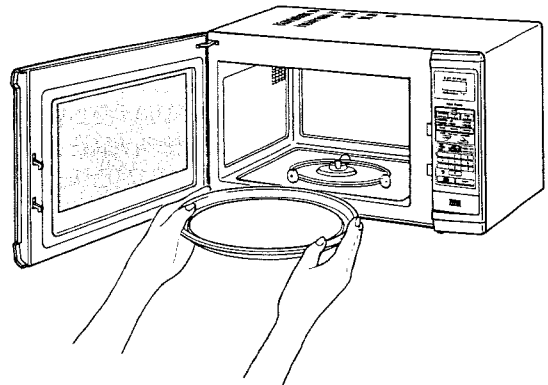
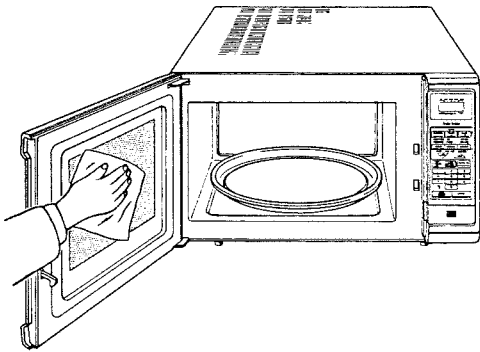

OVEN UTENSILS GUIDE

A variety of utensils and materials may be used for cooking in your microwave/convection oven. For your safety and to prevent damaging utensils and your oven, choose appropriate utensils and materials for each cooking method. The list below is a general guide for you to select utensils and materials.

Material	Utensils	Microwave Cooking	Micro/Convection Combination Cooking	Convection Cooking
Ceramic & Glass	Corning Ware	YES	YES	YES
	Heat resistant Glassware	YES	YES	YES
	Glassware with metal decoration	NO	NO	NO
	Lead Glass	NO	NO	NO
China	Without metal decoration	YES	YES	YES
Pottery	Without metal glaze	YES	YES	YES
Plastic	Regular Oven Heat-proof Ware	YES	YES	YES
	Plastic Wrap	YES	NO	NO
Metal	Metal Baking Pan	NO	NO	YES
	Aluminum Foil	*YES	YES	YES
Paper	Cups, Plates, Towels	YES	NO	NO
Waxed Paper		YES	NO	NO
Wood		NO	NO	NO

YES: Utensils to use
NO: Utensils to avoid

NOTE: *Aluminum Foil
For shielding purposes can be used when microwave cooking. See Cookbook for shielding techniques.

BEFORE CALLING FOR SERVICE

You can often correct operating problems yourself. If your micro/convection oven fails to work properly, locate the operating problem in the chart below and try the solutions marked for each problem.

If the micro/convection oven still does not work properly, contact the nearest Sears Service Center. Sears Service Centers are fully equipped to handle your service requirements.

PROBLEM

Oven Will Not Start	X	X	X								
"Err" display				X							
Arcing or Sparking					X	X					
Incorrect Time of Day							X				
Unevenly Cooked Foods					X			X	X	X	
Overcooked Foods										X	
Undercooked Foods					X				X	X	X
Improper Defrosting					X			X		X	

SOLUTION

- Is power cord plugged in? _____
- Is door closed? _____
- Cooking time not set. _____
- Touch STOP/CLEAR. _____
- Use approved cookware only. _____
- Do not operate with oven empty. _____
- Check to see that oven ventilation ports are not restricted. _____
- Use correct time/cooking power level. _____
- Completely defrost food. _____
- Turn or stir food. _____
- Reset time of day. _____

SEARS SERVICE

"WE SERVICE WHAT WE SELL"

"We Service What We Sell" is our assurance to you that you can depend on Sears for service because Sears service is nationwide.

Your Kenmore Microwave/Convection Oven has added value when you consider that Sears has a service unit near you, staffed by Sears Trained Technicians – professional technicians specifically trained on Kenmore Microwave/Convection Ovens, having the parts, tools and equipment to insure that we meet our pledge to you – "We Service What We Sell!"

TO FURTHER ADD TO THE VALUE OF YOUR MICROWAVE/CONVECTION OVEN, BUY A SEARS MAINTENANCE AGREEMENT.

Sears Microwave/Convection Ovens are designed, manufactured, and tested for years of dependable operation. Yet any modern appliance may require service from time to time. A Sears Maintenance Agreement is more than an extension of the Warranty.

It provides complete protection from unexpected repair bills and undue inconvenience. It assures you of maximum efficiency from your Microwave/Convection Oven.

Here's a comparative Warranty and Maintenance Agreement chart showing you the benefits of a Sears Microwave/Convection Oven Maintenance Agreement.

YEARS OF OWNERSHIP COVERAGE	1st Yr.	2nd Yr. thru 5th Yr.
1. Replacement of defective parts other than magnetron	W	MA
2. Replacement of magnetron	W	W
3. Annual preventative maintenance check at your request	MA	MA

W-WARRANTY

MA-MAINTENANCE AGREEMENT

Contact your Sears salesperson or local Sears Service Center today and purchase a Sears Maintenance Agreement.

SEARS

**USE & CARE
MANUAL**

**STOCK NO.
89969**

Kenmore[®]

**MICRO/CONVECTION
OVEN**

WARRANTY

**FULL ONE YEAR WARRANTY ON
MICROWAVE/CONVECTION OVEN**

FOR ONE YEAR FROM THE DATE OF PURCHASE, IF THIS KENMORE MICROWAVE/CONVECTION OVEN FAILS DUE TO A DEFECT IN MATERIAL OR WORKMANSHIP, SEARS WILL REPAIR IT, FREE OF CHARGE.

FULL FIVE YEAR WARRANTY ON THE MAGNETRON

FOR FIVE YEARS FROM THE DATE OF PURCHASE, IF THE MAGNETRON IN THIS KENMORE MICROWAVE/CONVECTION OVEN FAILS DUE TO A DEFECT IN MATERIAL OR WORKMANSHIP, SEARS WILL REPAIR IT, FREE OF CHARGE.

THE ABOVE WARRANTY COVERAGE APPLIES ONLY TO MICROWAVE/CONVECTION OVENS WHICH ARE USED FOR PRIVATE HOUSEHOLD PURPOSES.

**WARRANTY SERVICE IS AVAILABLE BY SIMPLY
CONTACTING THE NEAREST SEARS STORE OR SERVICE
CENTER IN THE UNITED STATES.**

THIS WARRANTY APPLIES ONLY WHILE THIS PRODUCT IS IN USE IN THE UNITED STATES.

THIS WARRANTY GIVES YOU SPECIFIC LEGAL RIGHTS, AND YOU MAY ALSO HAVE OTHER RIGHTS WHICH VARY FROM STATE TO STATE.

**SEARS, ROEBUCK AND CO.,
DEPT. 731CR-W, SEARS TOWER, CHICAGO, IL. 60684**