

**TOSHIBA**  
Leading Innovation >>>

# Owner's Manual

Integrated High Definition  
LCD Television

**46VX700U**

**55VX700U**

For an overview of steps for setting up your new TV, see page 11.

Note: To display a High Definition picture, the TV must be receiving a High Definition signal (such as an over-the-air High Definition TV broadcast, a High Definition digital cable program, or a High Definition digital satellite program). For details, please contact your TV antenna installer, cable provider, or satellite provider.

© 2010 TOSHIBA CORPORATION  
All Rights Reserved

## Owner's Record

The model number and serial number are on the back and side of your TV. Record these numbers in the spaces below. Refer to these numbers whenever you communicate with your Toshiba dealer about this TV.  
[www.tacp.toshiba.com/customersupport](http://www.tacp.toshiba.com/customersupport)

Model number: \_\_\_\_\_

Serial number: \_\_\_\_\_



TDM VX1A00174300

## Dear Customer,

Thank you for purchasing this Toshiba LCD TV. This manual will help you use the many exciting features of your new LCD TV. **Before operating your LCD TV, please read this manual completely**, and keep it nearby for future reference.

### Safety Precautions

**WARNING: TO REDUCE THE RISK OF FIRE OR ELECTRIC SHOCK, DO NOT EXPOSE THIS APPLIANCE TO RAIN OR MOISTURE.**

|  |  |   |
|--|--|---|
|   | <b>WARNING</b><br>RISK OF ELECTRIC SHOCK<br>DO NOT OPEN. |  |
| <b>WARNING: TO REDUCE THE RISK OF ELECTRIC SHOCK, DO NOT REMOVE COVER (OR BACK). NO USER-SERVICEABLE PARTS INSIDE. REFER SERVICING TO QUALIFIED SERVICE PERSONNEL.</b> |  |   |

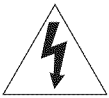

The lightning flash with arrowhead symbol, within an equilateral triangle, is intended to alert the user to the presence of uninsulated "dangerous voltage" within the product's enclosure that may be of sufficient magnitude to constitute a risk of electric shock to persons.

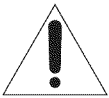

The exclamation point within an equilateral triangle is intended to alert the user to the presence of important operating and maintenance (servicing) instructions in the literature accompanying the appliance.

### WARNING

To prevent injury, this apparatus must be securely attached to the floor/wall in accordance with the installation instructions. See item 25 on p. 4 and instructions on p. 5.

**WARNING:** If you decide to wall mount this television, always use a UL Listed wall bracket appropriate for the size and weight of this television. The use of any wall bracket other than a UL Listed wall bracket appropriate for the size and weight of this television for wall mounting this television could result in serious bodily injury and/or property damage. See "Removing the Pedestal Stand" (p. 5).

### NOTE TO CATV INSTALLERS

This is a reminder to call the CATV system installer's attention to Article 820-40 of the U.S. NEC, which provides guidelines for proper grounding and, in particular, specifies that the cable ground shall be connected to the grounding system of the building, as close to the point of cable entry as practical. For additional antenna grounding information, see items 32 and 33 on p. 4.

## CHILD SAFETY:

It Makes A Difference How and Where You Use Your Flat Panel Display

**Congratulations on your purchase! As you enjoy your new product, please keep these safety tips in mind:**

### The Issue

The home theater entertainment experience is a growing trend and larger flat panel displays are popular purchases. However, flat panel displays are not always supported on the proper stands or installed according to the manufacturer's recommendations.

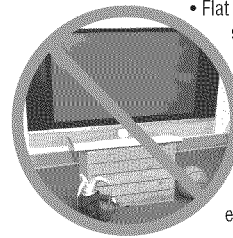

- Flat panel displays that are inappropriately situated on dressers, bookcases, shelves, desks, speakers, chests or carts may fall over and cause injury.

### TOSHIBA Cares!

- The consumer electronics industry is committed to making home entertainment enjoyable and safe.

### Tune Into Safety

- One size does NOT fit all. Follow the manufacturer's recommendations for the safe installation and use of your flat panel display.
- Carefully read and understand all enclosed instructions for proper use of this product.
- Don't allow children to climb on or play with furniture and television sets.
- Don't place flat panel displays on furniture that can easily be used as steps, such as a chest of drawers.
- Remember that children can become excited while watching a program, especially on a "larger than life" flat panel display. Care should be taken to place or install the display where it cannot be pushed, pulled over, or knocked down.
- Care should be taken to route all cords and cables connected to the flat panel display so that they cannot be pulled or grabbed by curious children.

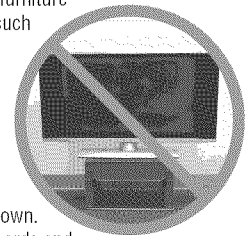



### Wall Mounting: If you decide to wall mount your flat panel display, always:

- Use a mount that has been recommended by the display manufacturer and/or listed by an independent laboratory (such as UL, CSA, ETL).
- Follow all instructions supplied by the display and wall mount manufacturers.
- If you have any doubts about your ability to safely install your flat panel display, contact your retailer about professional installation.
- Make sure that the wall where you are mounting the display is appropriate. Some wall mounts are not designed to be mounted to walls with steel studs or old cinder block construction. If you are unsure, contact a professional installer.
- A minimum of two people are required for installation. Flat panel displays can be heavy.

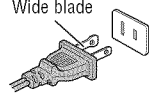
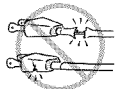

[www.CE.org/safety](http://www.CE.org/safety)

## Important Safety Instructions

- 1) **Read these instructions.**
  - 2) **Keep these instructions.**
  - 3) **Heed all warnings.**
  - 4) **Follow all instructions.**
- 
- 5) **Do not use this apparatus near water.**
- 
- 6) **Clean only with dry cloth.**
- 
- 7) **Do not block any ventilation openings.** Install in accordance with the manufacturer's instructions.
- 
- 8) **Do not install near any heat sources** such as radiators, heat registers, stoves, or other apparatus (including amplifiers) that produce heat.
- 
- 9) **Do not defeat the safety purpose of the polarized or grounding type plug.** A polarized plug has two blades with one wider than the other. A grounding type plug has two blades and a third grounding prong. The wide blade or the third prong are provided for your safety. If the provided plug does not fit into your outlet, consult an electrician for replacement of the obsolete outlet.  

- 
- 10) **Protect the power cord** from being walked on or pinched, particularly at plugs, convenience receptacles, and the point where they exit from the apparatus.  

- 
- 11) **Only use attachments/accessories specified by the manufacturer.**
- 
- 12) **Use only with the cart, stand, tripod, bracket, or table specified by the manufacturer, or sold with the apparatus.** When a cart is used, use caution when moving the cart/apparatus combination to avoid injury from tip-over.  

- 
- 13) **Unplug this apparatus during lightning storms or when unused for long periods of time.**
- 
- 14) **Refer all servicing to qualified service personnel.** Servicing is required when the apparatus has been damaged in any way, such as power-supply cord or plug is damaged, liquid has been spilled or objects have fallen into the apparatus, the apparatus has been exposed to rain or moisture, does not operate normally, or has been dropped.

## Additional Safety Precautions

- 14a) **CAUTION:** If the TV is dropped and the cabinet or enclosure surface has been damaged or the TV does not operate normally, take the following precautions:
  - ALWAYS turn off the TV and unplug the power cord to avoid possible electric shock or fire.
  - NEVER allow your body to come in contact with any broken glass or liquid from the damaged television. The LCD panel inside the TV contains glass and a toxic liquid. If the liquid comes in contact with your mouth or eyes, or your skin is cut by broken glass, rinse the affected area thoroughly with water and consult your doctor.





- ALWAYS contact a service technician to inspect the TV any time it has been damaged or dropped.

- 15) **CAUTION:**
    - To reduce the risk of electric shock, do not use the polarized plug with an extension cord, receptacle, or other outlet unless the blades can be inserted completely to prevent blade exposure.
    - To prevent electric shock, match wide blade of plug to wide slot; fully insert.
- 
- 16) **CAUTION:**  
Do not let children swallow the product or play with the plastic bag. Keep the product and the plastic bag out of the reach of children.
- 
- 17) **CAUTION:**  
Do not let water or other liquids come into contact with the product, as it may result in damage.
- 
- 18) **WARNING:**
    - To prevent the spread of fire, keep candles or other open flames away from this product at all times.
    - Keep the product away from direct sunlight, fire or a heat source such as a heater. This may reduce the product lifetime or result in fire.

## Installation, Care, and Service

### Installation

Follow these recommendations and precautions and heed all warnings when installing your TV:

- 19)  **WARNING: NEVER expose batteries to excessive heat such as sunshine, fire or the like.**
- 
- 20) ALWAYS plug the product into an outlet that is located in such a manner that it can be easily unplugged in case the product requires service.
- 
- 21) NEVER route the product's power cord inside a wall or similar enclosed area.
- 
- 22) Never modify this equipment. Changes or modifications may void: a) the warranty, and b) the user's authority to operate this equipment under the rules of the Federal Communications Commission.
- 
- 23)  **DANGER: RISK OF SERIOUS PERSONAL INJURY, DEATH, OR EQUIPMENT DAMAGE!**  
Never place the TV on an unstable cart, stand, or table. The TV may fall, causing serious personal injury, death, or serious damage to the TV.  

- 
- 24) To avoid damage to this product, never place or store the TV in direct sunlight; hot, humid areas; or areas subject to excessive dust or vibration.

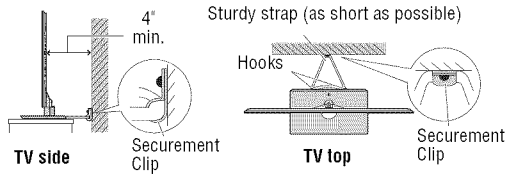
- 25) Always place the TV on the floor or a sturdy, level, stable surface that can support the weight of the unit. In order to maintain stability and prevent the TV falling over, secure the TV with a sturdy strap from the hooks on the rear of the TV pedestal to a wall stud, pillar, or other immovable structure. Make sure the strap is tight, secure, and parallel to the floor.



- 26) The apparatus shall not be exposed to dripping or splashing, and that no objects filled with liquids, such as vases, shall be placed on the apparatus.

- 27) Never block or cover the slots or openings in the TV cabinet back, bottom, and sides. Never place the TV:

- on a bed, sofa, rug, or similar surface;
- too close to drapes, curtains, or walls; or
- in a confined space such as a bookcase, built-in cabinet, or any other place with poor ventilation.

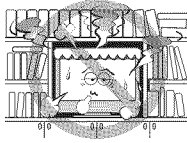

The slots and openings are provided to protect the TV from overheating and to help maintain reliable operation of the TV. Leave a space of at least 4 (four) inches around the TV.

- 28) Always place the back of the television at least 4 (four) inches away from any vertical surface (such as a wall) to allow proper ventilation.

- 29) Never allow anything to rest on or roll over the power cord, and never place the TV where the power cord is subject to wear or abuse.

- 30) Never overload wall outlets and extension cords.

- 31) Always operate this equipment from a 120 VAC, 60 Hz power source only.

- 32) Always make sure the antenna system is properly grounded to provide adequate protection against voltage surges and built-up static charges (see Section 810 of the National Electric Code).

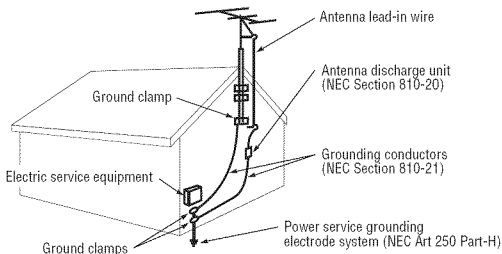

- 33)  **DANGER: RISK OF SERIOUS PERSONAL INJURY OR DEATH!**

- Use extreme care to make sure you are never in a position where your body (or any item you are in contact with, such as a ladder or screwdriver) can accidentally touch overhead power lines. Never locate the antenna near overhead power lines or other electrical circuits.
- Never attempt to install any of the following during lightning activity: a) an antenna system; or b) cables, wires, or any home theater component connected to an antenna or phone system.

## Care

For better performance and safer operation of your TOSHIBA TV, follow these recommendations and precautions:

- 34) If you use the TV in a room whose temperature is 32 °F (0 °C) or below, the picture brightness may vary until the LCD warms up. This is not a sign of malfunction.

- 35) Always unplug the TV before cleaning. When cleaning your TV, please first remove any dirt or dust from the surface. Gently wipe the cabinet and the display panel surface (the TV screen) with a dry, soft cloth only (cotton, flannel, etc.). The enclosed cleaning cloth is for cabinet cleaning. Harsh rubbing or use of a dirty or stiff cloth will scratch the TV surface. Avoid contact with alcohol, thinner, benzene, acidic or alkaline solvent cleaners, abrasive cleaners, or chemical cloths, which may damage the TV surface. Never spray volatile compounds such as insecticide on the TV surface. Such products may damage or discolor the TV.

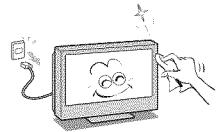

- 36) Never hit, press, or place anything on the back cover. These actions will damage internal parts.

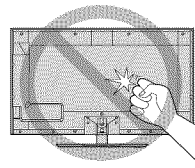

- 37)  **WARNING: RISK OF ELECTRIC SHOCK!** 

Never spill liquids or push objects of any kind into the TV cabinet slots.

- 38) While it is thundering, do not touch the connecting cables or apparatus.

- 39) For added protection of your TV from lightning and power surges, always unplug the power cord and disconnect the antenna from the TV if you leave the TV unattended or unused for long periods of time.

- 40) ALWAYS unplug the TV to completely disconnect from mains power. When the TV is turned off using the on/off switch, it is not completely disconnected from power and a minute amount of current is still consumed.

- 41) During normal use, the TV may make occasional snapping or popping sounds. This is normal, especially when the unit is being turned on or off. If these sounds become frequent or continuous, unplug the power cord and contact a Toshiba Authorized Service Center.



- 42)  **WARNING: RISK OF SERIOUS PERSONAL INJURY OR EQUIPMENT DAMAGE!**

Never strike the screen with a sharp or heavy object.



- 43) • The LCD screen of this product can be damaged by ultraviolet radiation from the sun. When selecting a location for the television, avoid locations where the screen may be exposed to direct sunlight, such as in front of a window.
- Never touch, press, or place anything on the LCD screen. These actions will damage the LCD screen. If you need to clean the LCD screen, follow the instructions in item 35 on p. 4.

## Service

- 44)  **WARNING: RISK OF ELECTRIC SHOCK!** 
- Never attempt to service the TV yourself. Opening and removing the covers may expose you to dangerous voltage or other hazards. Failure to follow this WARNING may result in death or serious injury. Refer all servicing not specified in this manual to a Toshiba Authorized Service Center.

- 45) If you have the TV serviced:
- Ask the service technician to use only replacement parts specified by the manufacturer.
  - Upon completion of service, ask the service technician to perform routine safety checks to determine that the TV is in safe operating condition.

## Choosing a location for your LCD TV

### To Display your LCD TV on the included Pedestal Stand:

Observe the following safety precautions:

- 1) Read and Follow the pedestal assembly instructions included with the pedestal.
 

**CAUTION:** Before beginning pedestal assembly, carefully lay the front of the LCD Panel face down on a flat, cushioned surface such as a quilt or blanket. Leave the bottom of the unit protruding over the edge of the surface and assemble the pedestal as indicated below.

**Note:** Extreme care should always be used when attaching the pedestal stand to avoid damage to the LCD panel.
- 2) Place the TV on a sturdy, level surface that can support the weight of the TV.
- 3) Be sure to secure the TV to a wall stud, pillar, surface, or other immovable structure. To secure the TV in this manner: (1) attach the provided securement clip to an immovable structure, then (2) pass a sturdy strap

through the securement clip and attach each end to the hooks located on the back of the TV. Be sure to leave at least 4 inches between the TV and the wall or similar structure for ventilation. See item 25, p. 4 for additional details.

### To Display your LCD TV using a Wall Bracket:

If you decide to wall mount your LCD TV, always use a UL Listed wall bracket appropriate for the size and weight of the LCD TV (see p. 2) :

#### CAUTION:

1. Two people are required for installation.
2. Never use the screws attached to the TV.
3. To install a wall-mount from another manufacturer, use the enclosed SPACERS.
  - 1) Unplug and remove any cables and/or other component connectors from the rear of the TV.
  - 2) Carefully lay the front of the unit face down on a flat, cushioned surface such as a quilt or blanket.
  - 3) Follow the instructions provided with your wall bracket. Before proceeding, make sure the appropriate bracket(s) are attached to the wall and the back of the TV as described in the instructions provided with the wall bracket.
  - 4) Make sure to place the spacers provided with the TV between the bracket and the back of the TV.
  - 5) Always use the screws supplied or recommended by the wall mount manufacturer.

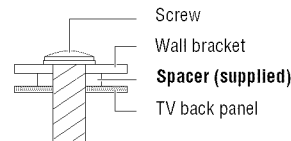
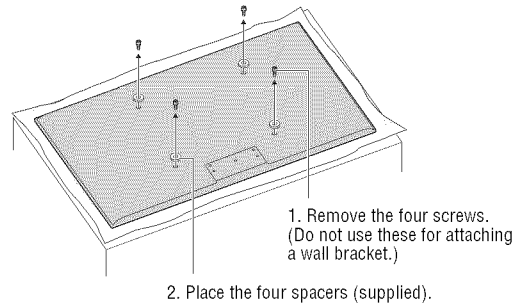

### Removing the Pedestal Stand

- 1) Carefully lay the front of the unit face down on a flat, cushioned surface such as a quilt or blanket. Leave the stand protruding over the edge of the surface.
 

**Note:** Extreme care should always be used when removing the pedestal stand to avoid damage to the LCD panel.
- 2) Remove the five screws.
- 3) Once you have removed all five screws holding the pedestal stand in place, remove the pedestal stand from the TV by sliding the pedestal stand away from the TV.

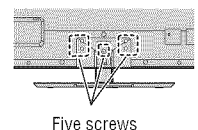

## **USA - Federal Communications Commission Statement**

### **FCC Compliance Statement**

This **Toshiba television models 46VX700U and 55VX700U** comply with Part 15 of the FCC Rules.

Operation is subject to the following two conditions:

- (1) This device may not cause harmful interference, and
- (2) This device must accept any interference received, including interference that may cause undesired operation.

The party responsible for compliance to these rules is:

Toshiba America Consumer Products, L.L.C.

82 Totowa Rd. Wayne, NJ 07470.

Ph: 1-800-631-3811

**Interference:** *This equipment has been tested and found to comply with the limits for a Class B digital device, pursuant to Part 15 of the FCC Rules. These limits are designed to provide reasonable protection against harmful interference in a residential installation.*

*This equipment generates, uses and can radiate radio frequency energy and, if not installed and used in accordance with the instructions, may cause harmful interference to radio communications. However, there is no guarantee that interference will not occur in a particular installation. If this equipment does cause harmful interference to radio or television reception, which can be determined by turning the equipment off and on, the user is encouraged to try to correct the interference by one of the following measures:*

- Reorient or relocate the receiving antenna.
- Increase the separation between the equipment and receiver.
- Connect the equipment into an outlet on a circuit different from that to which the receiver is connected.
- Consult the dealer or an experienced radio/TV technician for help.

### **Wireless Radio**

For product available in the USA/Canada market, only channel 1–11 can be operated. Selection of other channels is not possible.

The device could automatically discontinue transmission in case of absence of information to transmit, or operational failure. Note that this is not intended to prohibit transmission of control or signaling information or the use of repetitive codes where required by the technology.

If this device is going to be operated in 5.15–5.25GHz frequency range, then it is restricted in indoor environment only.

**Important:** *Any changes or modifications not expressly approved by the party responsible for compliance could void the user's authority to operate this equipment.*

*This device and its antenna(s) must not be co-located or operating in conjunction with any other antenna or transmitter.*

**FCC Radiation Exposure Statement:** *This equipment complies with FCC radiation exposure limits set forth for an uncontrolled environment. This equipment should be installed and operated with minimum distance 20cm between the radiator & your body.*

## **Canada - Industry Canada Statement**

This device complies with RSS-210.

Operation is subject to the following two conditions:

- (1) This device may not cause harmful interference, and
- (2) This device must accept any interference received, including interference that may cause undesired operation of the device.

This device and its antenna(s) must not be co-located or operating in conjunction with any other antenna or transmitter.

### **Wireless Radio**

For product available in the USA/Canada market, only channel 1–11 can be operated. Selection of other channels is not possible.

The device could automatically discontinue transmission in case of absence of information to transmit, or operational failure. Note that this is not intended to prohibit transmission of control or signaling information or the use of repetitive codes where required by the technology.

**Important:** *Any changes or modifications not expressly approved by the party responsible for compliance could void the user's authority to operate this equipment.*

### **IMPORTANT NOTE:**

**IC Radiation Exposure Statement:** *This equipment complies with IC RSS-102 radiation exposure limits set forth for an uncontrolled environment. This equipment should be installed and operated with minimum distance 20cm between the radiator & your body.*

## ENERGY STAR® User Information

ENERGY STAR User Information Statement: the factory default settings of this television meet ENERGY STAR® requirements. Enabling or changing certain features and functionality (e.g. Picture Settings, Auto Brightness Setting) may increase energy consumption, possibly beyond the limits required for ENERGY STAR qualification.

To ensure your television is operating at optimal energy efficiency, select [Home] mode during initial activation. To return to [Home] mode settings, select [AutoView] picture mode, and set the Auto Brightness Setting to [On] mode. [AutoView] mode is recommended for normal home use. For more information, see p. 48.



ENERGY STAR® qualified TV. Products that earn the ENERGY STAR prevent green house gas emissions by meeting strict guidelines set by the U.S. Environmental Protection Agency. ENERGY STAR and the ENERGY STAR mark are registered U.S. marks.

## Important notes about your LCD TV

The following symptoms are technical limitations of LCD Display technology and are not an indication of malfunction; therefore, Toshiba is not responsible for perceived issues resulting from these symptoms.

- 1) An afterimage (ghost) may appear on the screen if a fixed, non-moving image is displayed for a long period of time. The afterimage is not permanent and will disappear in a short period of time.
- 2) The LCD panel contained in this TV is manufactured using an extremely high level of precision technology; however, there may be an occasional pixel (dot of light) that does not operate properly (does not light, remains constantly lit, etc.). This is a structural property of LCD technology, is not a sign of malfunction, and is not covered under your warranty. Such pixels are not visible when the picture is viewed from a normal viewing distance.

**Note:** Interactive video games that involve shooting a "gun" type of joystick at an on-screen target may not work with this TV.

## Trademark Information

-  Manufactured under license from Dolby Laboratories.  
 Dolby and the double-D symbol are trademarks of Dolby Laboratories.
-  Audyssey EQ is based on the award-winning Audyssey MultEQ technology. It is the first-ever room equalization solution that can achieve optimum sound for a large listening area and it is featured in many high end home theater products. Audyssey EQ is used in the TV tuning process to calculate an equalization solution that corrects time and frequency response problems in TV systems. This results in clear, rich sound with more intelligible dialog.
- Manufactured under license from Audyssey Laboratories. U. S. and foreign patents pending. Audyssey EQ is a registered trademark of Audyssey Laboratories.
-  HDMI, the HDMI Logo, and High-Definition Multimedia Interface are trademarks or registered trademarks of HDMI Licensing LLC in the United States and other countries.
- INSTAPORT™ and INSTAPORT logo are trademarks of Silicon Image, Inc. in the United States and other countries.
- MPEG Layer-3 audio coding technology licensed from Fraunhofer IIS and Thomson.
-  SDHC Logo is a trademark.
- DLNA®, DLNA® Certification Logo and DLNA CERTIFIED™ are registered trademarks, trademarks, service marks, or certification marks of the Digital Living Network Alliance.
- VUDU is a trademark of VUDU, Inc .
- YouTube and the YouTube Logo are trademarks of Google Inc. in the United States and Canada.
- Netflix is a registered trademark of Netflix, Inc.
- This product contains NetFront Browser of ACCESS CO., LTD.
-  ACCESS™ ACCESS, the ACCESS logo and NetFront are trademarks or registered trademarks of ACCESS CO., LTD. in the United States, Japan and other countries.  
 NetFront™ © 2010 ACCESS CO., LTD. All rights reserved.  
This software is based in part on the work of the Independent JPEG Group.
- This product contains Adobe® Flash® Player software under license from Adobe Systems Incorporated. Copyright © 1995-2009 Adobe Systems Incorporated. All rights reserved. Adobe and Flash are trademarks of Adobe Systems Incorporated.
- This product contains the GStreamer Plugins copyrighted by Fluendo S.A.
- This product contains technology subject to certain intellectual property rights of Microsoft. Use or distribution of this technology outside of this product is prohibited without the appropriate license(s) from Microsoft.
- This product includes technology owned by Microsoft Corporation and can not be used or distributed without a license from Microsoft Licensing, GP.

- THIS PRODUCT IS LICENSED UNDER THE AVC PATENT PORTFOLIO LICENSE FOR THE PERSONAL AND NON-COMMERCIAL USE OF A CONSUMER TO (i) ENCODE VIDEO IN COMPLIANCE WITH THE AVC STANDARD (“AVC VIDEO”) AND/OR (ii) DECODE AVC VIDEO THAT WAS ENCODED BY A CONSUMER ENGAGED IN A PERSONAL AND NON-COMMERCIAL ACTIVITY AND/OR WAS OBTAINED FROM A VIDEO PROVIDER LICENSED TO PROVIDE AVC VIDEO. NO LICENSE IS GRANTED OR SHALL BE IMPLIED FOR ANY OTHER USE. ADDITIONAL INFORMATION MAY BE OBTAINED FROM MPEG LA, L. L. C. SEE [HTTP://WWW.MPEGLA.COM](http://www.mpegla.com)
- THIS PRODUCT IS LICENSED UNDER THE VC-1 PATENT PORTFOLIO LICENSE FOR THE PERSONAL AND NON-COMMERCIAL USE OF A CONSUMER TO (i) ENCODE VIDEO IN COMPLIANCE WITH THE VC-1 STANDARD (“VC-1 VIDEO”) AND/OR (ii) DECODE VC-1 VIDEO THAT WAS ENCODED BY A CONSUMER ENGAGED IN A PERSONAL AND NON-COMMERCIAL ACTIVITY AND/OR WAS OBTAINED FROM A VIDEO PROVIDER LICENSED TO PROVIDE VC-1 VIDEO. NO LICENSE IS GRANTED OR SHALL BE IMPLIED FOR ANY OTHER USE. ADDITIONAL INFORMATION MAY BE OBTAINED FROM MPEG LA, L. L. C. SEE [HTTP://WWW.MPEGLA.COM](http://www.mpegla.com)
- THIS PRODUCT IS LICENSED UNDER THE MPEG-4 VISUAL PATENT PORTFOLIO LICENSE FOR THE PERSONAL AND NON-COMMERCIAL USE OF A CONSUMER FOR (i) ENCODING VIDEO IN COMPLIANCE WITH THE MPEG-4 VISUAL STANDARD (“MPEG-4 VIDEO”) AND/OR (ii) DECODING MPEG-4 VIDEO THAT WAS ENCODED BY A CONSUMER ENGAGED IN A PERSONAL AND NON-COMMERCIAL ACTIVITY AND/OR WAS OBTAINED FROM A VIDEO PROVIDER LICENSED BY MPEG LA TO PROVIDE MPEG-4 VIDEO. NO LICENSE IS GRANTED OR SHALL BE IMPLIED FOR ANY OTHER USE. ADDITIONAL INFORMATION INCLUDING THAT RELATING TO PROMOTIONAL, INTERNAL AND COMMERCIAL USES AND LICENSING MAY BE OBTAINED FROM MPEG LA, L. L. C. SEE [HTTP://WWW.MPEGLA.COM](http://www.mpegla.com)



# Contents

|   |           |   |           |
|---|-----------|---|-----------|
| <b>Important Safety Instructions</b> . . . . .                                  | <b>3</b>  | Setting the PIN code . . . . .                                  | 35        |
| <b>Installation, Care, and Service</b> . . . . .                                | <b>3</b>  | Entering a new PIN code . . . . .                               | 35        |
| <b>Choosing a location for your LCD TV</b> . . . . .                            | <b>5</b>  | Changing or deleting your PIN code . . . . .                    | 35        |
| <b>Chapter 1: Introduction</b> . . . . .  | <b>11</b> | Forgotten PIN code . . . . .                                    | 35        |
| Features . . . . .  | 11        | Using parental controls . . . . .                               | 35        |
| Overview of installation, setup, and use . . . . .                              | 11        | Blocking TV programs and movies by rating<br>(V-Chip) . . . . . | 35        |
| Front panel controls . . . . .  | 12        | Downloading an additional rating system . . . . .               | 36        |
| Back panel connections . . . . .  | 12        | Displaying ratings . . . . .                                    | 37        |
| Bundling the cables . . . . .   | 13        | Unlocking programs . . . . .                                    | 37        |
| <b>Chapter 2: Connecting your TV</b> . . . . .                                  | <b>14</b> | Locking specific channels . . . . .                             | 37        |
| Overview of cable types . . . . .   | 14        | Locking video input . . . . .                                   | 37        |
| About the illustrations . . . . .   | 14        | Setting a time limit for games . . . . .                        | 38        |
| Connecting to Satellite dish, Antenna, or Cable TV . . . . .                    | 15        | Locking the control panel . . . . .                             | 38        |
| Connecting an HDMI® or DVI device to<br>the HDMI input . . . . .                | 16        | Using REGZA-LINK® . . . . .                                     | 38        |
| Connecting a VCR or DVD player with ColorStream®<br>(component video) . . . . . | 17        | Controlling REGZA-LINK® playback devices . . . . .              | 38        |
| Connecting remote IR devices . . . . .  | 18        | REGZA-LINK® input source selection . . . . .                    | 39        |
| Connecting a digital audio system . . . . .                                     | 19        | Adjusting the amplifier's audio . . . . .                       | 39        |
| Using the TV remote and REGZA-LINK® to control<br>other devices . . . . .       | 20        | Other REGZA-LINK® functions . . . . .                           | 39        |
| Connecting a HDMI audio system . . . . .  | 20        | Connecting a Toshiba PC compatible to<br>REGZA-LINK® . . . . .  | 40        |
| Connecting a PC . . . . .   | 21        | Using the HDMI® settings feature . . . . .                      | 40        |
| Connecting to a home network . . . . .  | 22        | Setting the HDMI® audio mode . . . . .                          | 41        |
| <b>Chapter 3: Using the remote control</b> . . . . .                            | <b>23</b> | Viewing the HDMI® signal information . . . . .                  | 41        |
| Controlling other devices . . . . .   | 23        | Using your PC with the TV . . . . .                             | 41        |
| Installing batteries . . . . .  | 23        | Adjusting the image . . . . .                                   | 41        |
| The remote's buttons . . . . .  | 24        | Setting the PC audio . . . . .                                  | 41        |
| <b>Chapter 4: Initial Setup and Menu</b> . . . . .                              | <b>25</b> | Setting the timer to turn on the TV . . . . .                   | 42        |
| Initial Setup . . . . .   | 25        | Setting the sleep timer . . . . .                               | 42        |
| Navigating the menu system . . . . .  | 26        | Setting Automatic Power Down . . . . .                          | 43        |
| Main menu layout . . . . .  | 27        | Setting No Signal Power Down . . . . .                          | 43        |
| Quick menu . . . . .  | 27        | Setting Blue Screen . . . . .                                   | 43        |
| <b>Chapter 5: Setting up your TV</b> . . . . .                                  | <b>28</b> | Adjusting POWER LED's Dimmer . . . . .                          | 43        |
| Changing Initial settings . . . . .   | 28        | Displaying TV status information . . . . .                      | 44        |
| Menu language . . . . .   | 28        | Viewing support information . . . . .                           | 44        |
| Local Time Setting . . . . .  | 28        | Resetting to Factory Defaults . . . . .                         | 44        |
| Location . . . . .  | 28        | Power failure . . . . .   | 44        |
| Smart Sound Equalizer . . . . .   | 28        | <b>Chapter 7: Picture and sound controls</b> . . . . .          | <b>45</b> |
| ANT/CABLE IN . . . . .  | 28        | Selecting the picture size . . . . .                            | 45        |
| Storing channels in memory (optional) . . . . .                                 | 28        | Scrolling the picture . . . . .                                 | 47        |
| Auto Tuning . . . . .   | 28        | Using the Auto Aspect feature . . . . .                         | 47        |
| Manual Tuning . . . . .   | 29        | Using the 4:3 Stretch . . . . .                                 | 47        |
| Skipping channels . . . . .   | 29        | Freezing the picture . . . . .                                  | 47        |
| Skipping video inputs . . . . .   | 29        | Adjusting the picture . . . . .                                 | 48        |
| Labeling video inputs . . . . .   | 30        | Selecting the picture mode . . . . .                            | 48        |
| Configuring shared inputs . . . . .   | 30        | Adjusting the picture quality . . . . .                         | 48        |
| Setting the Auto Input feature . . . . .  | 30        | Using the advanced picture settings features . . . . .          | 49        |
| <b>Chapter 6: Basic features</b> . . . . .                                      | <b>31</b> | Resolution+™ . . . . .  | 49        |
| Tuning channels . . . . .   | 31        | Dynamic Contrast . . . . .                                      | 49        |
| Setting the Channel Tuning Mode . . . . .                                       | 31        | DynaLight™ . . . . .  | 49        |
| Tuning to the next programmed channel . . . . .                                 | 31        | Static Gamma . . . . .  | 49        |
| Tuning to a specific channel<br>(programmed or unprogrammed) . . . . .          | 31        | Film Stabilization . . . . .                                    | 49        |
| Using the Channel Browser™ . . . . .  | 31        | ClearFrame 120™ feature . . . . .                               | 49        |
| Using Channel Return . . . . .  | 33        | MPEG NR . . . . .   | 50        |
| Using SurfLock™ . . . . .   | 33        | DNR . . . . .   | 50        |
| Selecting the video input to view . . . . .                                     | 33        | Smart Sensor . . . . .  | 50        |
| Using closed captions . . . . .   | 34        | Backlight Adjustment Pro . . . . .                              | 50        |
| Analog CC mode . . . . .  | 34        | Room Lighting . . . . .   | 50        |
| Digital CC settings . . . . .   | 34        | ColorMaster™ . . . . .  | 51        |
|   |           | Base Color Adjustment . . . . .                                 | 51        |
|   |           | Color temperature . . . . .                                     | 51        |
|   |           | Resetting to the factory default . . . . .                      | 51        |
|   |           | Expert Picture Settings . . . . .                               | 51        |
|   |           | Test Pattern . . . . .  | 51        |

|  |           |
|--|-----------|
| RGB Filter   | 51        |
| White Balance  | 51        |
| Resetting to the factory default                                   | 52        |
| Viewing the TV's brightness  | 52        |
| Locking the picture settings                                       | 52        |
| Adjusting the audio  | 53        |
| Muting the sound   | 53        |
| Selecting stereo/SAP broadcasts                                    | 53        |
| Adjusting the audio balance  | 53        |
| Selecting the optical audio output format                          | 53        |
| Using the Dolby® Digital Dynamic Range Control feature             | 54        |
| Using Dolby® Volume  | 54        |
| Using advanced sound features                                      | 54        |
| Using surround sound   | 54        |
| <b>Chapter 8: Advanced features</b>                                | <b>55</b> |
| Using your home network  | 55        |
| Setting up the Network   | 56        |
| Wireless Setup   | 56        |
| Advanced Network Setup   | 58        |
| Network Connection Test  | 59        |
| Using the software keyboard  | 60        |
| Performing a Software Upgrade                                      | 60        |
| Viewing the Software Licenses                                      | 60        |
| Using the NET TV™ feature  | 61        |
| NET TV menu  | 61        |
| Netflix  | 61        |
| VUDU™  | 62        |
| YouTube™   | 62        |
| Yahoo! TV Widgets  | 65        |
| Setting up the Media Renderer feature                              | 66        |
| Using the Media Player   | 68        |
| Media Player Specifications  | 68        |
| Basic operation  | 68        |
| Viewing Movie files  | 70        |
| Playing Music file   | 71        |
| Viewing Photo files  | 73        |
| Using the Photo Frame feature                                      | 74        |
| <b>Chapter 9: Troubleshooting</b>                                  | <b>76</b> |
| General troubleshooting  | 76        |
| LED indications  | 78        |
| <b>Chapter 10: Appendix</b>  | <b>79</b> |
| Specifications   | 79        |
| Acceptable signal formats for PC IN and HDMI terminals             | 80        |
| PC IN signal formats   | 80        |
| HDMI signal formats  | 81        |
| Remote control functional key chart                                | 82        |
| Operating other devices  | 85        |
| Programming the remote to operate other devices                    | 85        |
| Device code setup  | 85        |
| Searching for a device code  | 86        |
| Locking the volume keys  | 86        |
| Clearing the remote's programming                                  | 86        |
| Resetting to the factory default                                   | 86        |
| Operating TV with combination buttons                              | 87        |
| Remote control codes   | 88        |
| Limited United States Warranty for LCD Televisions                 | 94        |
| Limited Canadian Warranty for Toshiba Brand Flat Panel Televisions | 95        |
| <b>Index</b>   | <b>98</b> |

# Chapter 1: Introduction

## Features

- **Integrated digital tuning (8VSB ATSC and QAM)** eliminates the need for a separate digital converter set-top box (in most cases).
- **1080p output resolution.**
- **Four HDMI®** digital, High-Definition Multimedia Interfaces with 1080p input support (☞ p. 16).
- **HDMI capabilities**
  - ARC (Audio Return Channel)** enables the audio signal of the TV to be sent to the AV amplifier via the HDMI cable.
  - Content Type** adjusts the picture quality automatically for HDMI input content.
  - HDMI INSTAPORT™** technology reduces lag time when switching HDMI sources.
  - RGB Range** feature adjusts RGB full range signal automatically.
- **REGZA-LINK®** allows control of external devices from the TV remote via HDMI connection (☞ p. 38).
- **ColorStream® HD** high-resolution component video input.
- **Digital Audio Out** optical audio connection with Dolby® Digital optical output format (☞ p. 53).
- **PC IN (Analog RGB)** computer terminal (☞ p. 21).
- **IR IN/OUT** IR OUT is for controlling infrared remote-controlled devices through the TV. IR IN is for connecting to IR OUT on other devices (☞ p. 18).
- **Built-in WLAN** Allows the television to access your home wireless network without an external Dual Band WLAN Adapter.
- **Yahoo! TV Widgets** are Internet applications designed to run on your TV (☞ p. 65).
- **ColorMaster™** lets you adjust the TV's standard colors (☞ p. 51).
- **ClearFrame 120™** 120 Hz anti-blur feature (☞ p. 49).
- **Resolution+™** enhances the picture's quality (☞ p. 49).
- **AutoView™** lets you automatically adjust picture settings based on ambient light conditions and input signal content (☞ p. 48).
- **Dolby® Volume** eliminates inconsistent TV volume when changing channels or viewing commercials (☞ p. 54).
- **Media Player** lets you view photo files and play music or movie files (☞ p. 68).



ENERGY STAR® qualified

## Overview of installation, setup, and use

Follow these steps to set up your TV and begin using its many exciting features.

- 1 To choose a location for the TV:
  - Read "Important notes about your LCD TV" (☞ p. 7).
  - Place the TV in a proper location (☞ p. 2–5).
- 2 Do not plug in any power cords until AFTER you have connected all cables and devices to your TV.
- 3 BEFORE connecting cables or devices to the TV, learn the functions of the TV's connections and controls (☞ p. 12).
- 4 Connect your other electronic device(s) to the TV (☞ p. 14–22).
- 5 See "Chapter 3: Using the remote control" (☞ p. 23) for an overview of the buttons on the remote control, install the batteries and prepare to operate your other device(s).
- 6 AFTER connecting all cables and devices, plug in the power cords for your TV and other devices. When you turn on the TV, the Initial Setup menu appears.
- 7 See "Chapter 4: Initial Setup and Menu" for a quick overview of navigating the TV's menu system (☞ p. 25).
- 8 Program channels into the TV's channel memory (☞ p. 28).
- 9 See Chapters 6, 7 and 8, for details on using the TV's features.
- 10 For help, refer to the Troubleshooting Guide, on Chapter 9.
- 11 See Chapter 10, for technical specifications and warranty information.

## Front panel controls

Examples show Model 46VX700U.

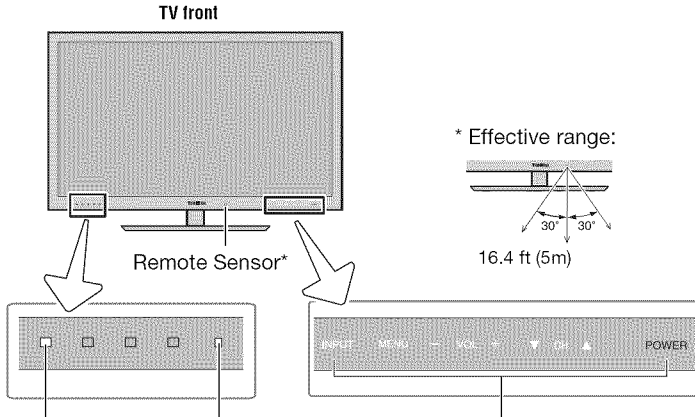

**On Timer LED**  
See p. 42.

**Smart Sensor**  
This sensor will detect the ambient light and color conditions (☞ p. 50).

**Touch Sensor**  
See “LED indications” (☞ p. 78).

### Touch key function:

- First touch: these only light up.
- Second touch: these are available.
- **POWER** – To turn the TV on and off.
- **▲ ▼** – To change the channel. When a menu is onscreen, these keys function as up/down menu navigation buttons.
- **+ -** – To adjust the volume level. When a menu is onscreen, these keys function as left/right menu navigation buttons.
- **MENU** – To access the menu. When a menu is onscreen, the MENU key on the TV’s control panel functions as the **RETURN** button.
- **INPUT** – To change the source you are viewing. When a menu is onscreen, the INPUT key on the TV’s control panel functions as the **OK** button.

## Back panel connections

For an explanation of cable types and connections, see p. 14–22.

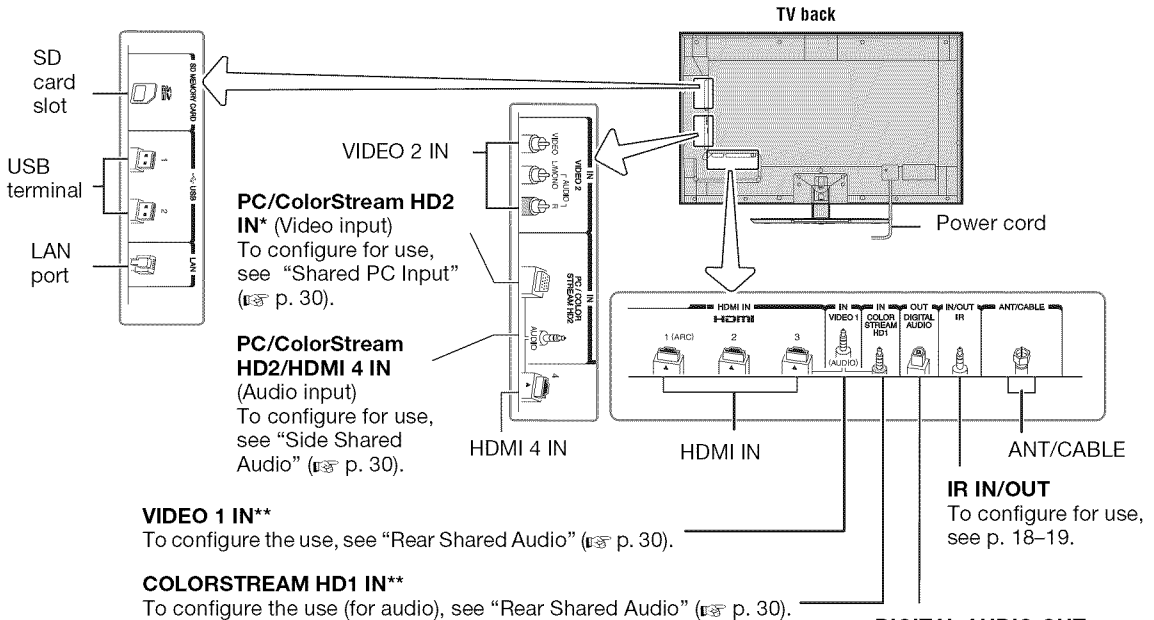

**VIDEO 1 IN\*\***  
To configure the use, see “Rear Shared Audio” (☞ p. 30).

**COLORSTREAM HD1 IN\*\***  
To configure the use (for audio), see “Rear Shared Audio” (☞ p. 30).

**IR IN/OUT**  
To configure for use, see p. 18–19.

**DIGITAL AUDIO OUT**  
See “Connecting a digital audio system” (☞ p. 19).

\* To use this input, an appropriate adapter (not supplied) is necessary.

\*\* To use these inputs, an appropriate adapter (supplied) is necessary.

## Bundling the cables

Install the cable clamps, and put the cables in these.

### Stand type

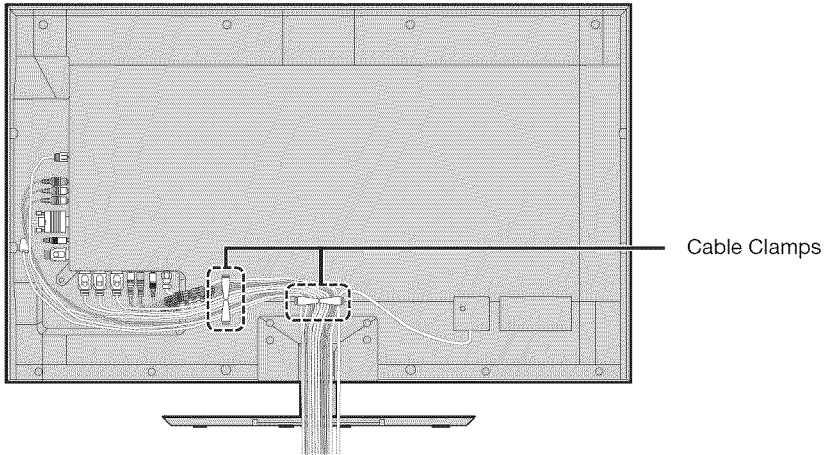

### Wall Mount type

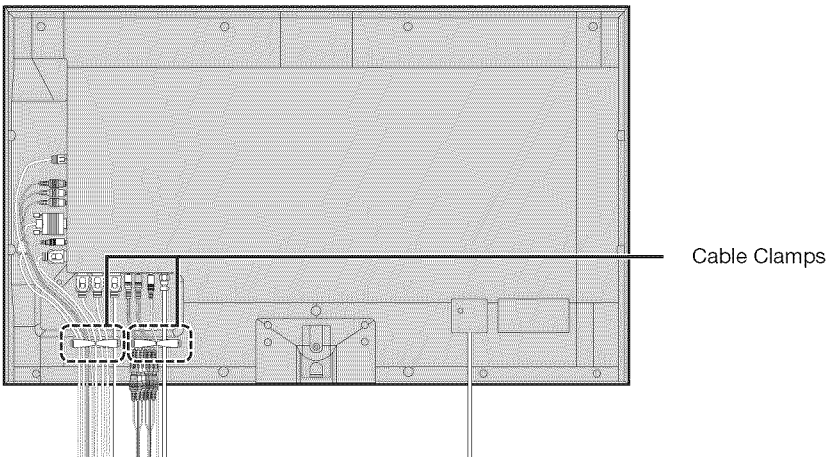

# Chapter 2: Connecting your TV

## Overview of cable types

Before purchasing cables, know the connector types your devices require. You can purchase cables from most stores that sell audio/video devices.

### Coaxial cable (F-type)



(F-type) Connects your antenna, cable TV service, or cable converter box on your TV.

### Standard A/V cables (composite video)

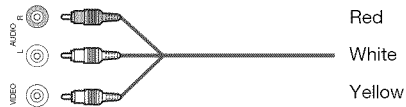

Use with video devices with analog audio and composite video output. These cables (and the related inputs on your TV) are often color-coded.

### Component video cables

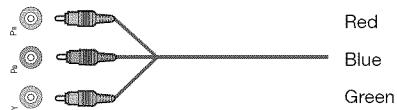

Use with video devices with component video output. Separate audio cables are required. (ColorStream® is Toshiba's brand.)

**Note:** Component video cables provide better picture quality than composite video cable.

### HDMI® cable (HDMI)



Use with devices with an HDMI output. An HDMI cable delivers digital audio and video in its native format. Separate audio cables are not required (see p. 16, 20–21).

**Note:** HDMI cables provide the best audio and picture quality.

### Dual-wand IR blaster cable



Use with video devices with infrared remote control. You can use this cable with the TV's IR pass-through feature (see p. 18).

To obtain IR blaster cables:  
Visit <http://ceaccessories.toshiba.com/>.

### Optical audio cable



Connects receivers with Dolby Digital or PCM (pulse-code modulation) optical audio input to the TV's **DIGITAL AUDIO OUT** terminal (see p. 19).

### Analog RGB (15-pin) computer cable

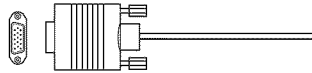

Connects a PC to the TV's **PC IN** terminal (see p. 21).

**Note:** Separate audio cables are required.

### Standard/Crossover LAN cable

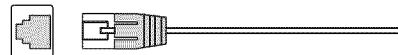

Standard LAN cable is used to connect the TV to your home network (see p. 22).

Crossover LAN cable is used to connect the TV directly to a PC (see p. 22).

## About the illustrations

**Note:** The connection illustrations shown are representative of typical device connections only. The input/output terminals on your devices may differ. See each device's owner's manual.

## Connecting to Satellite dish, Antenna, or Cable TV

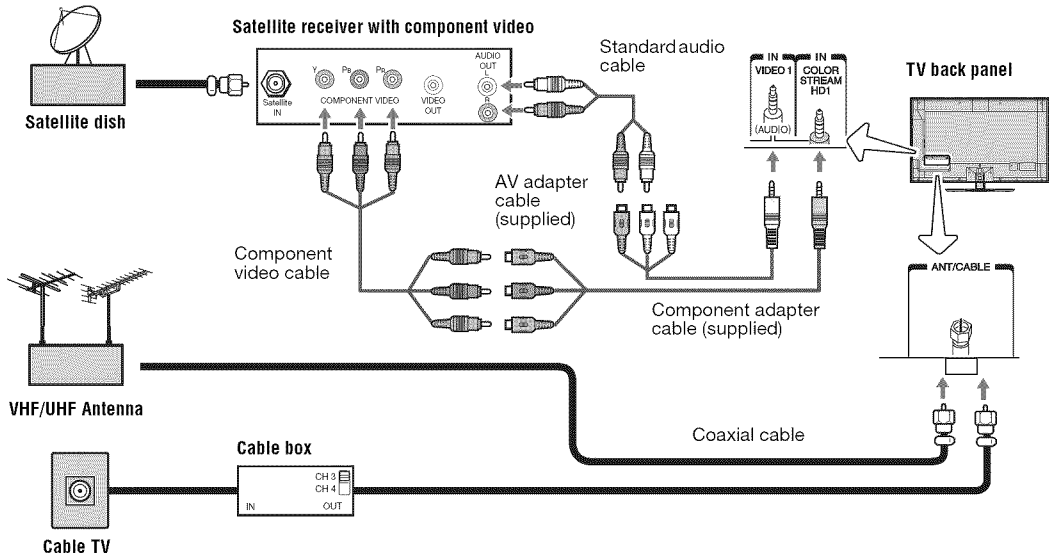

### You will need:

- Coaxial cables
- AV adapter cable (supplied)
- Standard audio cable
- Component adapter cable (supplied)
- Component video cable

### To view satellite programs using the component video connections:

Turn on the satellite receiver. Press **(INPUT)** and **▲** or **▼** to select the **ColorStream HD1**. Use the satellite receiver's controls to change channels.

### To view the antenna or cable signal:

Press **(INPUT)** and **▲** or **▼** to select the **ANT/CABLE**.

### To view basic and premium cable channels:

Turn on the cable box. Press **(INPUT)** and **▲** or **▼** to select the **ANT/CABLE**. Tune the TV to channel 3 or 4 (the channel the cable box output is set to). Use the cable box's controls to change channels.

The unauthorized recording, use, distribution, or revision of television programs, videotapes, DVDs, and other materials is prohibited under the Copyright Laws of the United States and other countries, and may subject you to civil and criminal liability.

## Connecting an HDMI® or DVI device to the HDMI input

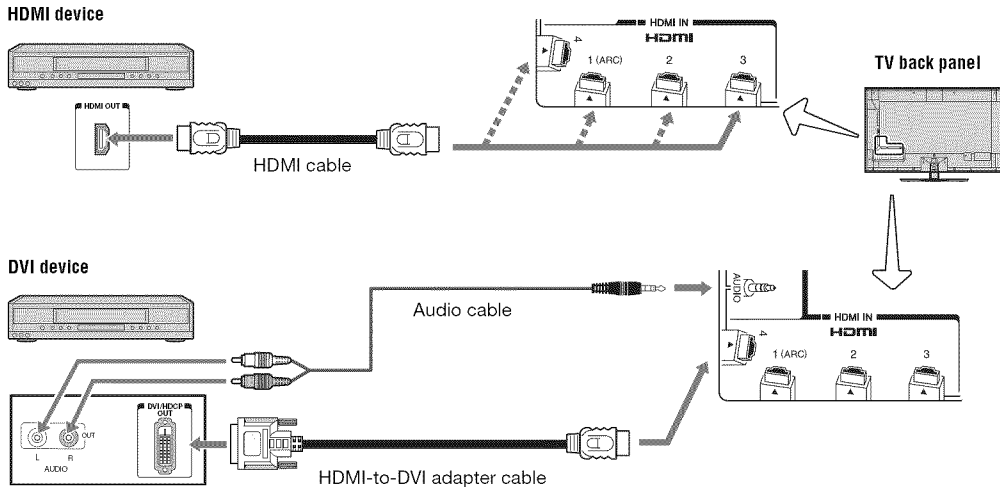

The HDMI input on your TV receives digital audio and uncompressed digital video from an HDMI source device, or uncompressed digital video from a DVI (Digital Visual Interface) source device.

This input is designed to accept HDCP (High-Bandwidth Digital-Content Protection) program material in digital form from EIA/CEA-861-D compliant[1] consumer electronic devices (such as a set-top box or DVD player with HDMI or DVI output). Supported signal formats: VGA, SVGA, XGA, WXGA, SXGA, 480i (60Hz), 480p (60Hz), 720p (60Hz), 1080i (60Hz), 1080p (24Hz/60Hz). For signal specifications, see p. 81.

Supported Audio format: Linear PCM, sampling rate 32/44.1/48 kHz.

**Note:**

- To connect a PC to the HDMI input, see p. 21.
- Some legacy HDMI sources may not work properly with your HDMI TV, due to the adoption of new standards. Try the HDMI setting to Off (p. 40).

**To connect an HDMI device, you will need:**

- one HDMI cable per HDMI device
  - Recommendation: For proper operation, use an HDMI cable with the HDMI Logo (**HDMI**).
  - To display an 1080p/60 Hz signal format, you need a High Speed HDMI cable. Conventional HDMI/DVI cable may not work properly.
  - HDMI cable transfers video and audio. Separate analog audio cables are not required.
  - See “Setting the HDMI audio mode” (p. 41).

**To view the HDMI device video:**

Press (INPUT) and ▲ or ▼ to select the **HDMI 1**, **HDMI 2**, **HDMI 3** or **HDMI 4**.

**Note:** To program the TV remote control to operate other devices, see p. 85.

**To connect a DVI device, you will need:**

- One HDMI-to-DVI adapter cable
  - For proper operation, the length of an HDMI-to-DVI adapter cable must not exceed 9.8 ft (3m). Recommended length: 6.6 ft (2m).
- One 3.5mm Stereo to RCA Y-Cable
  - Analog audio for HDMI is only available on HDMI 3 and HDMI 4. Configuration is needed. See p. 30, 41.
  - An HDMI-to-DVI adapter cable transfers video only. Separate analog audio cables are required.

**Note:** To ensure that the HDMI or DVI device is reset properly:

- To turn on electronic components, **turn on the TV first** and then the HDMI or DVI device.
- To turn off electronic components, **turn off the HDMI or DVI device first** and then the TV.

[1] EIA/CEA-861-D compliance covers the transmission of uncompressed digital video with high-bandwidth digital content protection, which is being standardized for reception of high-definition video signals. Because this is an evolving technology, it is possible that some devices may not operate properly with the TV



## Connecting a VCR or DVD player with ColorStream® (component video)

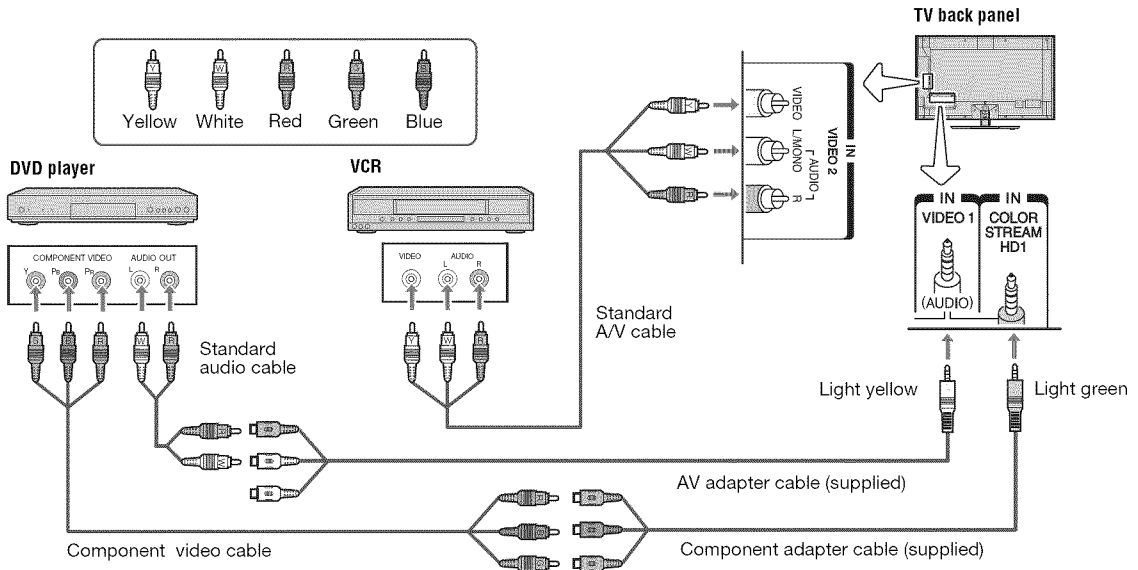

### You will need:

- Standard A/V cable
- AV adapter cable (supplied)
- Standard audio cable
- Component adapter cable (supplied)
- Component video cable
  - You can connect the component video cables from the DVD player to the **ColorStream HD1** terminal on the TV. Separate audio cables are required. You can use the **ColorStream HD1** terminal to display Progressive (480p, 720p, 1080p) and Interlaced (480i, 1080i). Check the owner's manual of the DVD player in order to determine the best output signal available (1080p 24 Hz/30 Hz/50 Hz/25 Hz are not supported).
  - If your DVD player does not have component video, connect a composite video cable to **VIDEO 2** on the side panel. If your DVD player has HDMI video, see p. 16.

### To view the DVD player:

Turn on the DVD player. Press **(INPUT)** and **▲** or **▼** to select **ColorStream HD1**. Audio configuration is needed. See "Rear Shared Audio" (p. 30), and select **ColorStream HD1**.

### To view the VCR or view and record antenna channels:

Turn on the VCR. Tune the VCR to the channel you want to watch. Press **(INPUT)** and **▲** or **▼** to select **Video 2**.

**Note:** To program the TV remote control to operate other devices, see p. 85.

The unauthorized recording, use, distribution, or revision of television programs, videotapes, DVDs, and other materials is prohibited under the Copyright Laws of the United States and other countries, and may subject you to civil and criminal liability.

## Connecting remote IR devices

### Using the IR OUT terminal

You can use the TV's IR OUT terminal to remotely operate many infrared remote-controlled devices enclosed in an entertainment center or similar cabinet.

#### You will need:

- Dual-wand IR blaster cable (see p. 14)
- Other cables as required to connect the device(s) to the TV (see p. 15, 16 and 17)

#### To set the IR OUT mode:

- 1 **MENU** > **PREFERENCES** > **IR Control**.
- 2 Press **◀** or **▶** to select **Out**.

#### To connect the IR blaster cable:

- 1 Locate the infrared sensor on the front of your device. This sensor is marked on some devices.\*
- 2 Align one of the IR blaster cable's wands about 1 inch away from the infrared sensor on the front of the device and attach it using double-sided mounting tape. If you have a second device, attach the second wand in a similar manner.

**Note:** If you do not have a second device, coil the second wand with a rubber band and leave it behind the TV.

- 3 Plug the IR blaster cable's plug into the TV's **IR OUT** terminal.

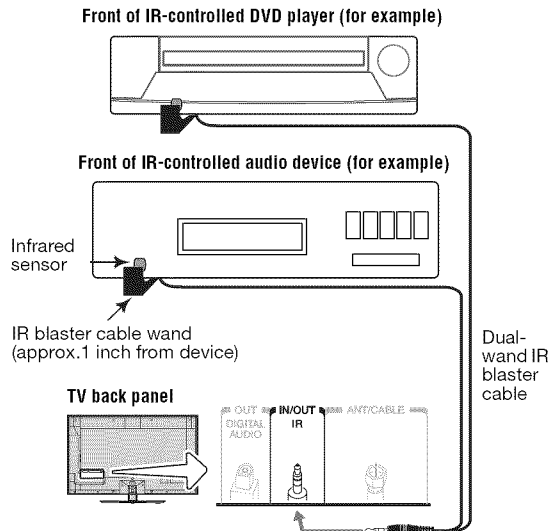

#### To control the device(s):

Point either the device's remote control or the TV remote control (that you previously programmed to operate the device; see Chapter 3) toward the front of the TV and press the button for the desired function. The signal passes from the remote control through the TV to the device via the IR blaster cable.

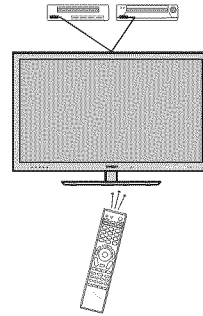

#### Note:

- To program the remote control to operate the device(s), see "Programming the remote to operate other devices" (see p. 85).
- The IR pass-through feature does not support all IR-controlled devices. Satisfactory quality may not be attainable with certain devices.

#### \*If you cannot locate the device's infrared sensor:

- 1 Turn off the device.
- 2 Starting at the device's lower-left corner, place the end of the device's remote control (with the infrared emitter) so it touches the front of the device. Press **POWER**. (Do not use the TV's remote control for this step.)
- 3 If the device turns on, the sensor is located where the remote control touched the device.
- 4 If the device does not turn on, move the remote control slightly to the right and press **POWER** again.
- 5 Repeat the previous steps if necessary.

### Using the IR IN terminal

For additional control options for your home theater system, you can connect an IR receiver/repeater control system (not included) to the TV's IR IN terminal.

**You will need:**

- IR cable

To set the IR IN mode:

- 1 **MENU** > **PREFERENCES** > **IR Control**.
- 2 Press **◀** or **▶** to select **IN**.

Back of IR receiver/repeater control system (not included)

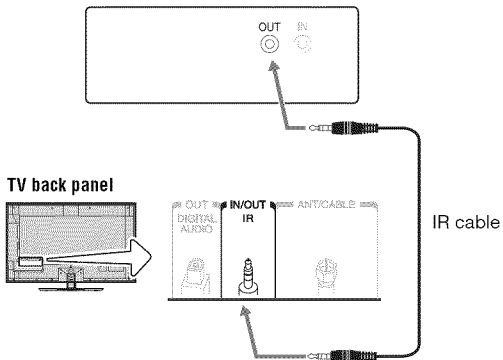

To operate the TV with this connection, point the Toshiba TV remote control toward the front of the IR receiver/repeater control system.

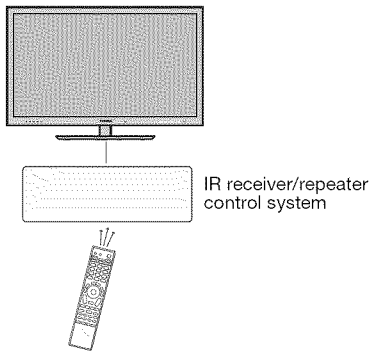

**To view the HDMI device video:**

Press **(INPUT)** and **▲** or **▼** to select the **HDMI 1**, **HDMI 2**, **HDMI 3** or **HDMI 4**.

**Note:** To program the TV remote control to operate other devices, see p. 85.

**To connect a DVI device, you will need:**

- One HDMI-to-DVI adapter cable

### Connecting a digital audio system

The TV's **DIGITAL AUDIO OUT** terminal outputs a Dolby® Digital or 2-channel down-mixed PCM (pulse-code modulation) signal for use with an external Dolby Digital decoder or other external audio system with optical audio input.

**You will need:**

- Optical audio cable (Use an optical audio cable that has the larger TosLink connector, not the smaller mini-optical connector.)

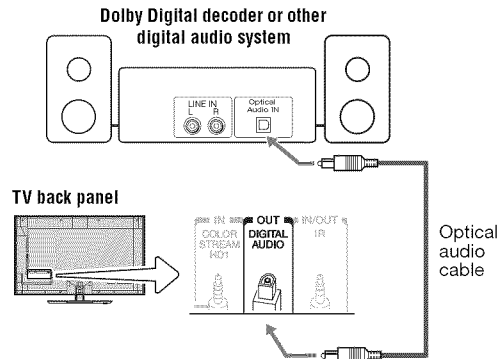

**Before controlling the audio:**

- See "Selecting the optical audio output format" (p. 53).

**Note:**

- Some audio systems may not be compatible with Dolby Digital bitstream signals. Older audio systems that are not compatible with standard optical out signals may not work properly, creating a high noise level that may damage speakers or headphones. **THIS DAMAGE IS NOT COVERED BY YOUR WARRANTY.**
- The **DIGITAL AUDIO OUT** terminal may not output some digital audio sources because of copy restrictions.
- The Dolby Digital format is available in the following situations:
  - When tuned to a digital RF channel.
  - When DLNA Certified products or VUDU is used.

Manufactured under license from Dolby Laboratories. Dolby, and the double-D symbol are trademarks of Dolby Laboratories.

## Using the TV remote and REGZA-LINK® to control other devices

To control the basic functions of connected audio/video devices using the TV's remote control, connect a REGZA-LINK® compatible audio receiver or playback device. The REGZA-LINK® feature uses the CEC technology as regulated by the HDMI standard.

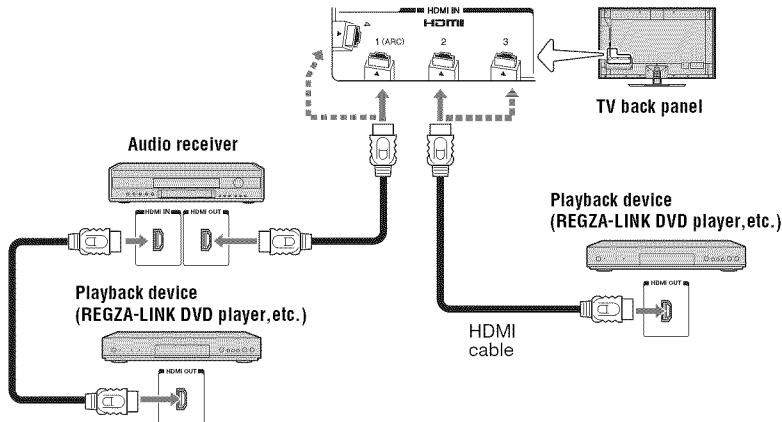

To connect an audio receiver and playback devices, you will need:

- HDMI cables (see p. 14)

**Note:**

- If several devices are connected, the REGZA-LINK® feature may not operate properly.
- For proper operation, it is recommended that you use HDMI cables with the HDMI Logo (**HDMI**).

**Before controlling the devices:**

- For an explanation of setup and operations, see "Using REGZA-LINK®" (see p. 38).
- Configure the connected devices. See each device's operation manual.

**Note:** This feature is limited to models incorporating Toshiba's REGZA-LINK. However, Toshiba is not liable for those operations. See the individual instruction manuals for compatibility information.

**When using an external AV amplifier:**

Picture and sound may not be properly synchronized. In this case, adjust the delay time of sound on the AV amplifier.

**Note:** Control range of the delay time differs according to the device you use.

## Connecting a HDMI audio system

If your HDMI amplifier supports ARC, audio from the TV can be sent to the amplifier over the existing HDMI cable.

**You will need:**

- HDMI cable

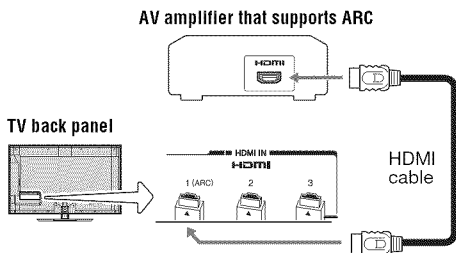

**HDMI's ARC (Audio Return Channel) feature**

This feature enables the audio signal of the TV to be sent to the AV amplifier via the HDMI cable. It will not be necessary to connect a cable from the audio output of the TV to the audio input of the AV amplifier to reproduce the audio received from the tuner of the TV through the AV amplifier.

## Connecting a PC

You can watch your PC's display on the TV and hear the sound from the TV's speakers.

### Connecting to the TV's PC IN terminal

You will need:

- Analog RGB (15-pin) computer cable
- PC audio cable

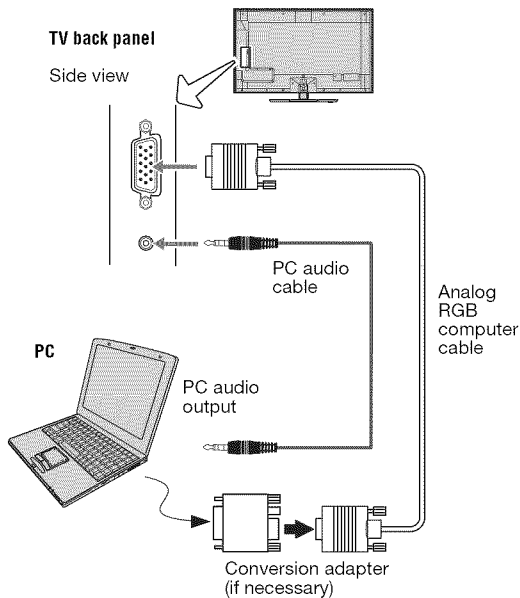

**Before using the PC:**

See "Using your PC with the TV" (p. 41).

**To use a PC:**

- Set the monitor output resolution on the PC before connecting it to the TV.
- Supported signal formats: VGA, SVGA, XGA, WXGA, SXGA. For signal specifications, see p. 80.

**Note:**

- The PC audio input terminal on the TV is shared with the HDMI 4 and ColorStream HD2 terminal. To configure for use, see "Setting the PC audio" (p. 41).
- Some PC models cannot be connected to this TV.
- If the PC has a compatible mini D-sub 15-pin terminal, an adapter is not required.
- Depending on the DVD's title and the PC's specifications, some scenes may be skipped or you may not be able to pause during multi-angle scenes.

Signal names for mini D-sub 15-pin connector

| Pin No. | Signal name | Pin No. | Signal name | Pin No. | Signal name |
|---------|-------------|---------|-------------|---------|-------------|
| 1       | R           | 6       | Ground      | 11      | NC          |
| 2       | G           | 7       | Ground      | 12      | NC          |
| 3       | B           | 8       | Ground      | 13      | H-sync      |
| 4       | NC *        | 9       | NC          | 14      | V-sync      |
| 5       | NC          | 10      | Ground      | 15      | NC          |

\* NC=Not connected

### Connection to the TV's HDMI terminal

You will need:

If your PC has no HDMI terminal:

- Adapter cable
- Analog audio cable

If your PC has HDMI or DVI terminal:

- HDMI cable or HDMI-to-DVI adapter cable

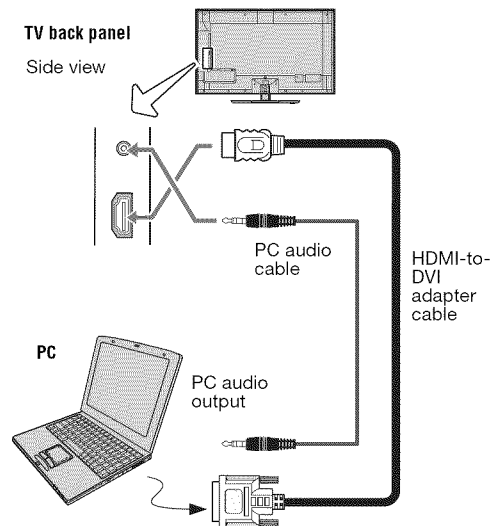

Supported signal formats: VGA, SVGA, XGA, WXGA, SXGA, 480i (60Hz), 480p (60Hz), 720p (60Hz), 1080i (60Hz), 1080p (24Hz/60Hz). For signal specifications, see p. 81.

**Note:**

- The edges of the images may be hidden.
- The PC audio input terminal on the TV is shared with the HDMI 4 and ColorStream HD2 terminal. To configure for use, see "Setting the PC audio" (p. 41).

## Connecting to a home network

The LAN port allows your Toshiba TV to connect to your home network.

You can use this home network to access photo, movie and music files that are stored on a DLNA CERTIFIED™ Server and play them on your TV.

### Connecting the TV directly to a PC without an Internet connection

You will need:

- Crossover LAN cable

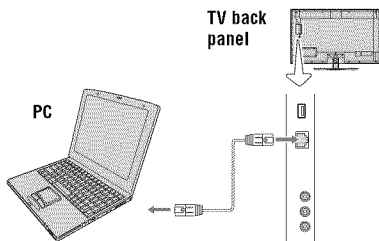

### Connecting the TV to a home network without an Internet connection

You will need:

- Standard LAN cables
- Router with Hub

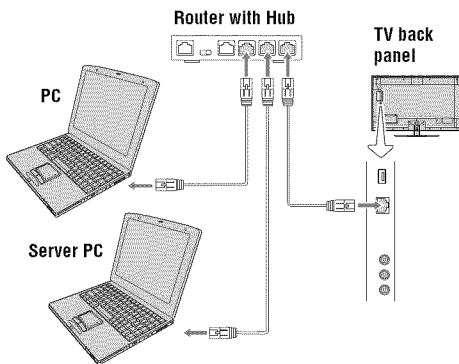

### Connecting the TV to a home network with an Internet connection - Wired

You will need:

- Coaxial or telephone cable (depending on your modem type)
- Standard LAN cables
- Router with Hub
- Modem (DSL or cable)

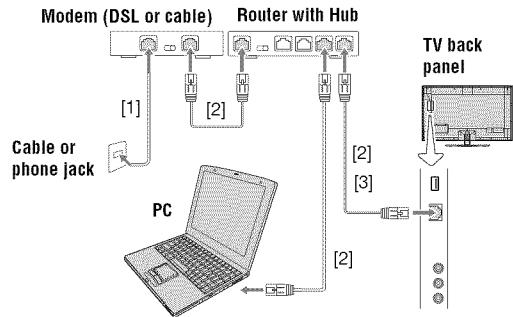

- [1] Coaxial or telephone cable (depending on your modem type)
- [2] Standard LAN cable
- [3] Do NOT connect a phone jack directly to the TV's LAN port.

### Connecting the TV to a home network with an Internet connection - Wireless

You will need:

- Coaxial or telephone cable (depending on your modem type)
- Standard LAN cables
- Wireless LAN access point
- Modem (DSL or cable)

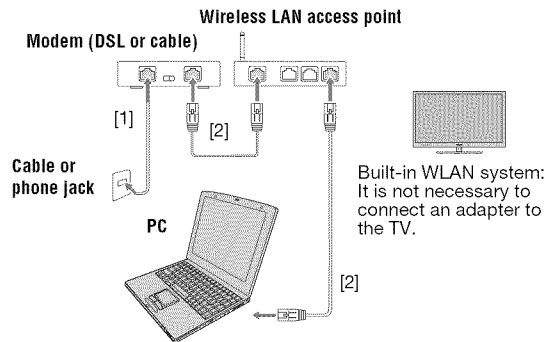

The transmission speed over the wireless LAN and the distance over which wireless LAN can reach may vary depending on surrounding electromagnetic environment, obstacles, access point design and configuration, and client design and software/hardware configurations. The actual transmission speed will be lower than the theoretical maximum speed.

- [1] Coaxial or telephone cable (depending on your modem type)
- [2] Standard LAN cable

# Chapter 3: Using the remote control

## Controlling other devices

The TV's remote control can operate other devices such as cable converter boxes, satellite receivers, VCRs, DVD players, and HTIBs (home theater in a box).

### Toshiba device:

The remote is programmed to operate these devices (Ⓜ p. 85).

### Non-Toshiba device or a Toshiba device that the remote control is not programmed to operate:

Program the remote (Ⓜ p. 85).

## Installing batteries

- 1 Slide off the cover.

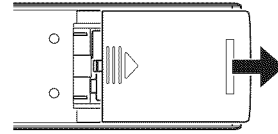

- 2 Install two AA size carbon zinc batteries.

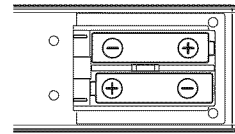

- 3 Slide on the cover.

**Caution:** Do not expose batteries to excessive heat such as sunshine, fire or the like.

### Note:

- Every time you change the batteries, you must reprogram the remote.
- Dispose of batteries in a designated disposal area.
- Always consider the environment when disposing of batteries. Always follow applicable laws and regulations.
- If the remote does not operate correctly, or if the operating range becomes reduced, replace the batteries.
- Always replace both batteries with new ones. Never mix battery types or use new and used batteries together.
- Always remove batteries from the remote if they are dead or if the remote control is not being used for an extended period of time. This prevents battery acid from leaking into the battery compartment.

## The remote's buttons

The buttons described in this section operate the TV only.

For the REGZA-LINK functions, see "Using REGZA-LINK®" (p. 38).

For a complete list of the remote's functions, see "Remote control functional key chart" (p. 82–84).

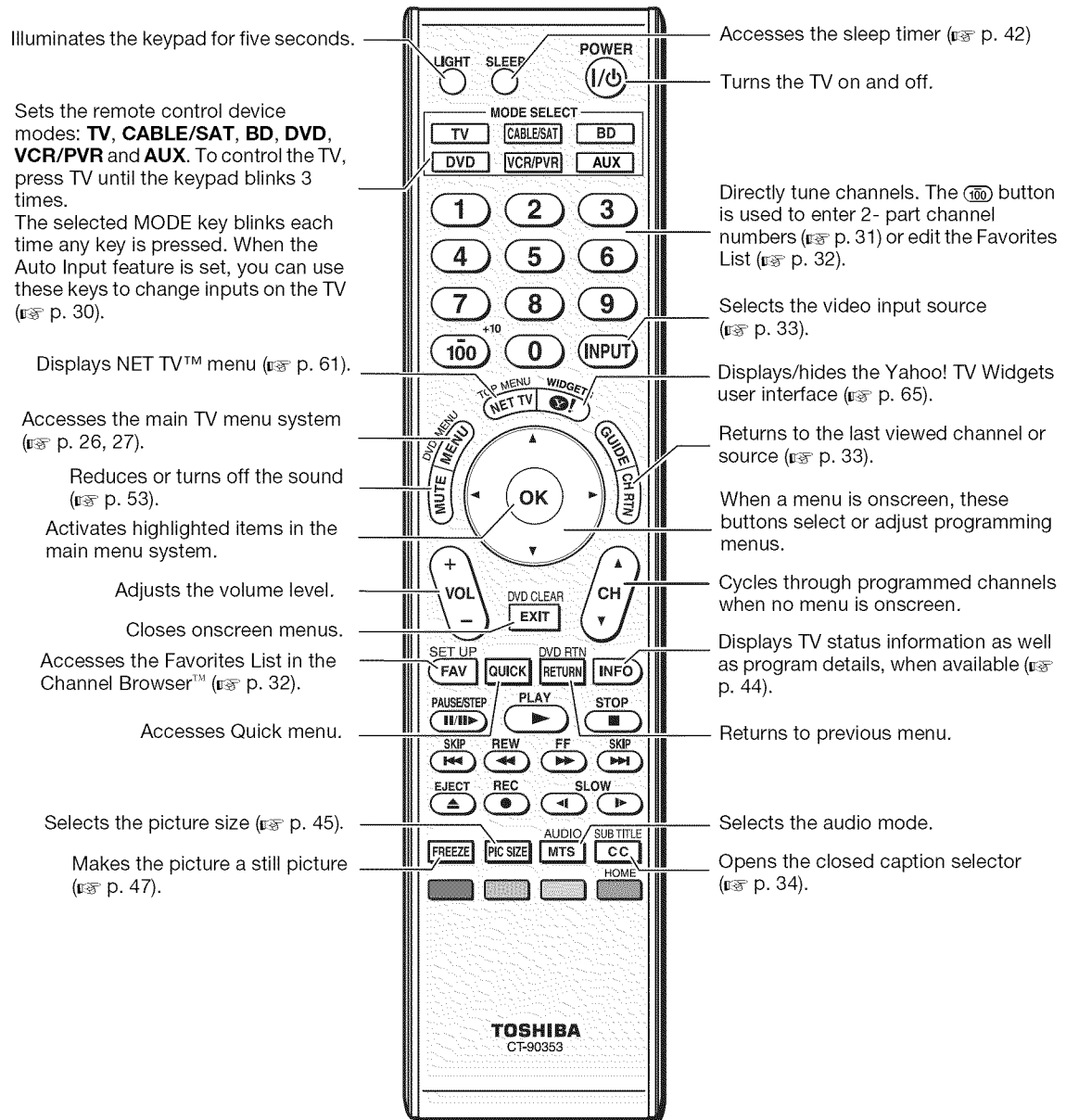

**Note:** The error message "NOT AVAILABLE" may appear if you press a key for a function that is not available.



# Chapter 4: Initial Setup and Menu

## Initial Setup

When you first turn on or reset the TV, the Initial Setup window will appear.

### Note:

- You can stop the Initial Setup by pressing **EXIT**. However, if you do not finish the Initial Setup, the Initial Setup screen will appear every time you turn on your TV. To finish, see “Changing Initial settings” (p. 28).
- EXIT** does not work until **Menu Language/Time Zone/Location** have been set.

### 1 Menu Language



Select a language. Press **OK**.

### 2 Time Zone

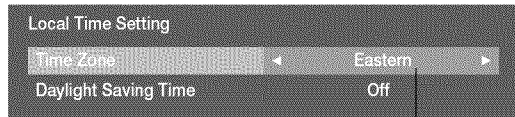

Set a time zone.

### 3 Daylight Saving Time



Select **On** or **Off**. Press **OK**.

### 4 Location

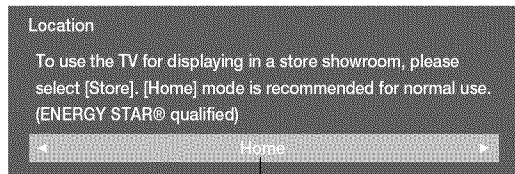

Select **Home** for normal home use. Press **OK**.

### 5 TV Mounting

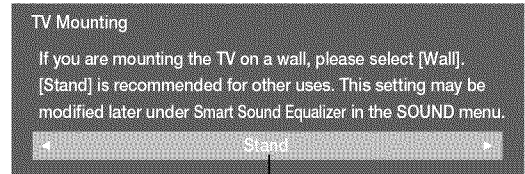

Select **Stand** or **Wall**. Press **OK**.

### 6 ANT/CABLE

If you select **Antenna**:

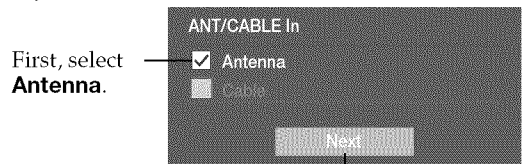

First, select **Antenna**.

Second, select **Next**. Press **OK**.

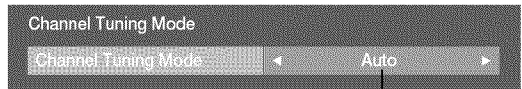

Select **Auto**, **Digital**, or **Standard** (see “Setting the Channel Tuning Mode” on p. 31). Press **OK**.

If you select **Cable**:

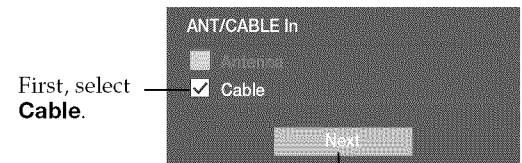

First, select **Cable**.

Second, select **Next**. Press **OK**.

**Note:** If you do not want to scan channels, you do not need to make a selection for **ANT/CABLE**. Select **Next** and press **OK** to skip this step.

## 7 Start Scan

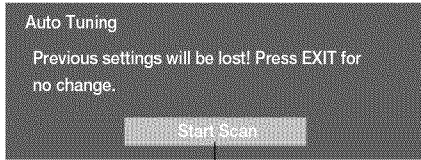

Press **OK**.

**Note:** If you want to stop scanning, press **EXIT** while scanning.

- After scanning completes, a channel list screen (such as the one below) appears.

| Auto Tuning (Antenna)      |  |      |        |
|----------------------------|--|------|--------|
| Antenna Channels Found: 14 |  |      |        |
| Ch.                        |  | Type | RF Ch. |
| 2                          |  | ATV  | 2      |
| 4-1                        |  | DTV  | 4      |
| 4-2                        |  | DTV  | 4      |
| 6                          |  | ATV  | 6      |
| 11                         |  | ATV  | 11     |
| 13                         |  | ATV  | 13     |
| 18                         |  | ATV  | 18     |
| 31                         |  | ATV  | 31     |

### If channels are not found after scanning:

- Check the antenna / cable connections, and scan again.
- Connect the TV to the antenna or cable box directly and scan again.

- 1 **MENU** > **SETUP** > **Quick Setup** > **OK**.
  - 2 A confirmation message appears. Press **◀** or **▶** to select **Yes**. Press **OK**.
  - 3 Set up to step 6.
    - If you selected **Antenna** in the previous setting, select **Cable**.
    - If you selected **Cable** in the previous setting, select **Antenna**.
  - 4 Scan again.
- Refer to information on [www.tacp.toshiba.com/customersupport](http://www.tacp.toshiba.com/customersupport).

## Navigating the menu system



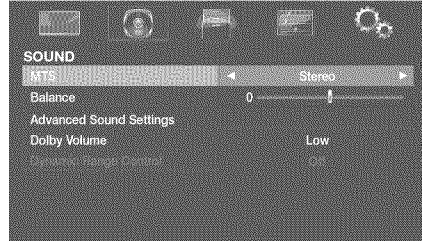

- To open the main menu, press **MENU** on the remote control or TV control panel.



- Press **▲**, **▼**, **◀** or **▶** on the remote control or TV control panel to navigate and make selections.
- To select a menu option, press **OK**. To return to the previous menu page, press **RETURN**.
- To close a menu instantly, press **MENU** or **EXIT**.
- All menus will close automatically if you do not make a selection within 60 seconds.



## Main menu layout

To open the main menus (illustrated below), press  on the remote control or TV control panel.

| Icon  | Item  | Page               |
|---|---|--------------------|
|    | Picture Mode  | 48                 |
|   | Reset   | 48                 |
|   | Backlight   | 48                 |
|   | Contrast  | 48                 |
|   | Brightness  | 48                 |
|   | Color   | 48                 |
|   | Tint  | 48                 |
|   | Sharpness   | 48                 |
|   | Advanced Picture Settings   | 49                 |
|   | Expert Picture Settings   | 51                 |
|   | Control Visualization   | 52                 |
|   | TheaterLock   | 52                 |
|   |  | MTS                |
| Balance   |   | 53                 |
| Advanced Sound Settings   |   | 54                 |
| Dolby Volume  |   | 54                 |
| Dynamic Range Control   |   | 54                 |
|   | Widgets   | 65                 |
|   | NET TV  | 61                 |
|   | Media Player  | 68                 |
|   | Channel Browser   | 31                 |
|   | Favorites Browser   | 32                 |
|   | On Timer  | 42                 |
|  | Sleep Timer   | 42                 |
|   | REGZA-LINK Setup  | 40                 |
|   | Network Setup   | 56                 |
|   | Netflix Setup   | 62                 |
|   | VUDU Deactivation   | 62                 |
|   | Media Renderer Setup  | 66                 |
|   | Photo Frame Setup   | 74                 |
|   | Channel Browser Setup   | 31                 |
|   | PIN Setting   | 35                 |
|   | Parental Control and Locks  | 35                 |
|   | Display Settings  | 41, 47             |
|   | AV Connection   | 29, 30, 40, 41, 53 |
|   | Auto Input  | 30                 |
|   | IR Control  | 18                 |
|   | Energy Saving Settings  | 43                 |
| Blue Screen   | 43  |                    |

| Icon  | Item                     | Page               |
|---|--------------------------|--------------------|
|  | HDMI Information Display | 41                 |
|   | POWER LED Dimmer         | 43                 |
|   | Menu Language            | 28                 |
|   | ANT/CABLE In             | 28                 |
|   | Auto Tuning              | 28                 |
|   | Manual Tuning            | 29                 |
|   | TV Settings              | 28, 29, 31, 34, 37 |
|   | Quick Setup              | 28                 |
|   | Location                 | 28                 |
|   | Software Upgrade         | 60                 |
| Software Licences   | 60                       |                    |
| System Information  | 44                       |                    |
| Reset TV  | 44                       |                    |

## Quick menu

Quick menu helps you access some options quickly. Press  to display the Quick menu and press  or  to select the option.

**Note:** Quick menu items are different depending on the current mode.

| Quick menu Item           | Page       |
|---------------------------|------------|
| PICTURE                   | 45–52      |
| Picture Mode              | 48         |
| Picture Size              | 45         |
| Photo Frame               | 74         |
| Sort                      | 70, 72, 73 |
| Repeat                    | 70, 72, 73 |
| SOUND                     | 53–54      |
| Background Music          | 73         |
| Speakers                  | 39         |
| Channel Browser           | 31         |
| Media Player              | 68         |
| REGZA-LINK Player Control | 39         |
| Sleep Timer               | 42         |
| Interval Time             | 73         |
| Device Information        | 69         |
| Wireless Information      | 58         |

# Chapter 5: Setting up your TV

How to navigate the menu:

**MENU** > Main menu > Submenu > **OK**

| Format      | Description  |
|-------------|--|
| <b>MENU</b> | Press the <b>MENU</b> button.  |
| > Main menu | Press <b>◀</b> or <b>▶</b> to select a menu icon ( <b>PICTURE, SOUND, APPLICATIONS, PREFERENCES, SETUP</b> ) |
| > Submenu   | Press <b>▲</b> or <b>▼</b> to select a desired menu.   |
| > <b>OK</b> | Press the <b>OK</b> button   |

## Changing Initial settings

From Quick Setup:

- 1 **MENU** > **SETUP** > **Quick Setup** > **OK**.
- 2 A confirmation message appears. Press **◀** or **▶** to select **Yes**. Press **OK**.
- 3 To change settings, see “Initial Setup” (p. 25).

From individual setting:

## Menu language

You can choose from three different languages (**English, Français** and **Español**) for menus and messages

- 1 **MENU** > **SETUP** > **Menu Language**.
- 2 Press **◀** or **▶** to select your preferred language. Press **EXIT**.

## Local Time Setting

This setting allows you to specify the correct time zone for your region.

- 1 **MENU** > **SETUP** > **TV Settings** > **OK**.
- 2 Press **▲** or **▼** to select **Local Time Setting**. Press **OK**.
- 3 Select an option:
  - **Time Zone**
  - **Daylight Saving Time**
- 4 Press **◀** or **▶** to set your desire time zone or to select **On** to activate **Daylight Saving Time**. Press **EXIT**.

## Location

You can select Home or Store for the TV location. For normal home use, select Home.

- 1 **MENU** > **SETUP** > **Location**.
- 2 Press **◀** or **▶** to select **Home**. Press **EXIT**.

## Smart Sound Equalizer

You can adjust the sound for the TV installation.

- 1 **MENU** > **SOUND** > **Advanced Sound Settings** > **OK**.
- 2 Press **▲** or **▼** to select **Smart Sound Equalizer**. Press **OK**.
- 3 Highlight **TV Mounting**. Select **Stand** or **Wall**.
- 4 If you want to adjust the equalizer, press the **RED** button.
- 5 Press **▲**, **▼**, **◀** or **▶** to adjust.
- 6 Press **EXIT** to fix the adjustment.  
To cancel the selection or adjustment, select **Cancel** on the screen. Press **OK**.  
To revert the selection or adjustment to the factory default, select **Reset** on the screen. Press **OK**.

## ANT/CABLE IN

This setting configures the antenna input source for the ANT/CABLE terminal.

- 1 **MENU** > **SETUP** > **ANT/CABLE In**.
- 2 Press **◀** or **▶** to select the input source (**Antenna** or **Cable**) for the **ANT/CABLE** input. Press **EXIT**.

## Storing channels in memory (optional)

To make your TV stops only on the channels you want when you press **▲** or **▼** on the remote control or the control panel, store those channels in the TV's memory.

## Auto Tuning

**Note:** You must set up the antenna/cable input source first. See “Initial Setup” (p. 25).

You can set up the TV to detect all active channels in your area and store them in its memory. Then you can manually store or skip individual channels from memory.

| Option  | Description  |
|---------|--|
| Cable   | <b>Note:</b> If you select Cable, auto tuning deletes previously stored channels from memory.<br>This setup requires some time, but you do not need to repeat the setup unless your cable TV service's lineup changes significantly. |
| Antenna | Auto tuning retains stored channels and stores newly found channels into memory.<br>To skip an antenna source channel from memory, set the channel to be skipped. See "Skipping channels".   |

**Note:** To tune to channels not stored in memory, use buttons 0–9 and (100) on the remote control.

- 1 **MENU** > **SETUP** > **Auto Tuning** > (OK).  
A confirmation screen appears.
- 2 Press (OK) to start Auto Tuning or **EXIT** to abort.  
The TV cycles through all the channels, and stores all active channels in memory.  
To view the programmed channels, press (CH+) or (CH-).

## Manual Tuning

After storing channels in memory, you can manually enter channels if the physical channel is known.

- 1 **MENU** > **SETUP** > **Manual Tuning** > (OK).
- 2 Use buttons 0–9 on the remote control to enter the channel number (for example, 56) and press (OK).
- 3 Press (OK) to start Manual Tuning.

The channels found are listed at the bottom of the screen.

| Type | Description     |
|------|-----------------|
| ATV  | Analog channel. |
| DTV  | Digital channel |

## Skipping channels

To prevent a channel from being viewed, you can set it to be skipped.

- 1 **MENU** > **SETUP** > **TV Settings** > (OK).
- 2 Press **▲** or **▼** to select **Channel Options**. Press (OK).  
The list of channels appears.

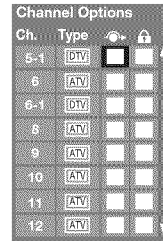

- 3 Press **▲** or **▼** to select a channel to skip. Press (OK).  
The box is selected. To clear the selection, press (OK).

**Note:** You cannot tune to skipped channels using (CH+) or (CH-). Use buttons 0–9 and (100) on the remote control.

## Skipping video inputs

You can set video inputs to be skipped over when selecting inputs in the Input selection window.

To turn on skip:

- 1 **MENU** > **PREFERENCES** > **AV Connection** > (OK).
- 2 Press **▲** or **▼** to select **Input Labeling**. Press (OK).
- 3 Press **▲** or **▼** to select the item you want to be skipped. Press the **RED** button to turn on **Skip**.

To turn off skip:

- 1 **MENU** > **PREFERENCES** > **AV Connection** > (OK).
- 2 Press **▲** or **▼** to select **Input Labeling**. Press (OK).
- 3 Press **▲** or **▼** to select the skipped item. Press the **RED** button to turn off **Skip**.

## Labeling video inputs

The input labels are shown in the input selector, and in the Channel Browser and banner displays. You can label video inputs according to the devices you have connected to the TV.

- 1 **MENU** > **PREFERENCES** > **AV Connection** > **OK**.
- 2 Press **▲** or **▼** to select **Input Labeling**. Press **OK**.
- 3 Press **▲** or **▼** to select the item you want to label. Press **◀** or **▶** to select **--**, **Amplifier**, **Cable**, **DVD**, **Game**, **PC**, **Recorder**, **Satellite** or **VCR**, or press the **GREEN** button to select **User Input**.

**Note:** When *User Input* is selected by pressing the **GREEN** button, the *Software Keyboard* window will appear. Input the desired characters (10 characters or fewer) by using the *Software Keyboard* (see p. 60) or using the number buttons for a number input. To save your settings, press the **BLUE** button.

- 4 Repeat step 3 for other video inputs.

## Configuring shared inputs

### Rear Shared Audio

- 1 **MENU** > **PREFERENCES** > **AV Connection** > **OK**.
- 2 Press **▲** or **▼** to select **Rear Shared Audio**.
- 3 Press **◀** or **▶** to select **ColorStream HD1**, **Video 1**, or **HDMI 3**.

### Side Shared Audio

- 1 **MENU** > **PREFERENCES** > **AV Connection** > **OK**.
- 2 Press **▲** or **▼** to select **Side Shared Audio**.
- 3 Press **◀** or **▶** to select **PC (ColorStream HD2)** or **HDMI 4**.

### Shared PC Input

- 1 **MENU** > **PREFERENCES** > **AV Connection** > **OK**.
- 2 Press **▲** or **▼** to select **Shared PC Input**.
- 3 Press **◀** or **▶** to select **PC** or **ColorStream HD2**.

## Setting the Auto Input feature

You can change TV inputs using the **MODE SELECT** buttons on the remote control: **TV**, **CABLE/SAT**, **BD**, **DVD**, **VCR/PVR**, **AUX**. After setting an input for a specific **MODE SELECT** button, the TV automatically switches to the input when you press and hold the **MODE SELECT** button for 2 seconds and release it. Auto Input settings options for each **MODE SELECT** button:

| Mode      | Inputs   |
|-----------|--|
| TV        | ANT/CABLE  |
| CABLE/SAT | ANT/CABLE, Video 1, Video 2, ColorStream HD1, HDMI 1, HDMI 2, HDMI 3, HDMI 4, PC (ColorStream HD2) |
| BD        | Video 1, Video 2, ColorStream HD1, HDMI 1, HDMI 2, HDMI 3, HDMI 4, PC (ColorStream HD2)            |
| DVD       | Video 1, Video 2, ColorStream HD1, HDMI 1, HDMI 2, HDMI 3, HDMI 4, PC (ColorStream HD2)            |
| VCR/PVR   | ANT/CABLE, Video 1, Video 2, ColorStream HD1, HDMI 1, HDMI 2, HDMI 3, HDMI 4, PC (ColorStream HD2) |
| AUX       | Video 1, Video 2, ColorStream HD1, HDMI 1, HDMI 2, HDMI 3, HDMI 4, PC (ColorStream HD2)            |

**Note:** The TV mode select button will be restricted to the *ANT/CABLE* input.

### To set Auto Input:

- 1 **MENU** > **PREFERENCES** > **Auto Input** > **OK**
- 2 Set **Enable Auto Input** to **On**.
- 3 Press **▲** or **▼** to select the mode you want to set.
- 4 Press **◀** or **▶** to select an input source for that mode.
- 5 Repeat the procedure for other modes.

### To turn off Auto Input:

Select **Off** in step 2.

### To reset Auto Input:

Select **Reset**. Press **OK**.

# Chapter 6: Basic features

## Tuning channels

### Setting the Channel Tuning Mode

You can select how tuning is handled for analog and digital channels when the TV is in Antenna mode.

**Note:** To use this feature, **ANT/CABLE In** must be set to **Antenna** (see p. 28).

- 1 **MENU** > **SETUP** > **TV Settings** > **OK**.
- 2 Press **▲** or **▼** to highlight **Channel Tuning Mode**.

| Mode           | Description  |
|----------------|--|
| Standard       | You can tune both analog and digital channels normally.  |
| Auto (default) | Digital channels have priority when manually entering a channel number using the 0-9 buttons on the remote. To tune analog channels, use <b>▲</b> / <b>▼</b> if available. |
| Digital        | You can only tune digital channels.  |

- 3 Press **◀** or **▶** to select a mode. Press **EXIT**.

**Note:** The Channel Options screen and the Channel Browser ANT/CABLE List update when you change the mode. The History List clears, but the Favorites List is saved.

### Tuning to the next programmed channel

Press **▲** or **▼** on the remote control or TV control panel.

**Note:** This feature does not work unless you store channels in the TV's channel memory (see p. 28).

### Tuning to a specific channel (programmed or unprogrammed)

| Channel | Description   |
|---------|---|
| Analog  | Press the 0-9 buttons on the remote control. (For example, to select channel 125, press 1, 2, 5.) Press <b>OK</b> .   |
| Digital | Press the 0-9 buttons on the remote control to enter the major channel number. Press the dash ( <b>100</b> ) button. Enter the sub-channel number. (For example, to select digital channel 125-1, press 1, 2, 5, -, 1.) Press <b>OK</b> . |

## Using the Channel Browser™

The Channel Browser™ is a helpful navigational interface for all of your channels and inputs.

Features:

- Navigate the contents of all of your inputs.
- Keep a list of your favorite channels.
- Keep a history of the last 32 channels or inputs viewed.
- Quickly surf and tune your recently viewed channels/inputs from the Channel Browser™ History List.
- Surf via Browse mode (to immediately tune channels as you highlight them in the Channel Browser™) or Select mode (to surf channels in the Channel Browser™ before you select one to tune).
- Quickly change inputs from the Inputs List.
- Quickly select REGZA-LINK® devices from the REGZA-LINK List.

To set up the Channel Browser™:

- 1 **MENU** > **PREFERENCES** > **Channel Browser Setup** > **OK**.
  - 2 Press **▼** or **▲** to highlight **Navigation**.
  - 3 Press **◀** or **▶** to select **Select Mode** or **Browser Mode**.
  - 4 Select a list.
    - **History List**
    - **ANT/CABLE List**
    - **Inputs List**
    - **Favorites List**
    - **REGZA-LINK List**
- Note:**
- History List will be cleared every time the TV is powered off.
  - REGZA-LINK List will be automatically not available and set to off when **Enable REGZA-LINK** is set to **Off** (see p. 40).
- 5 Select **On** or **Off**.
  - 6 To return to factory defaults, highlight **Reset** and press **OK**.

To open the Channel Browser™:

- **MENU** > **APPLICATIONS** > **Channel Browser** > **OK**.
- Press **QUICK**, and select **Channel Browser**.
- Press **FAV**.

### Elements of the Channel Browser™

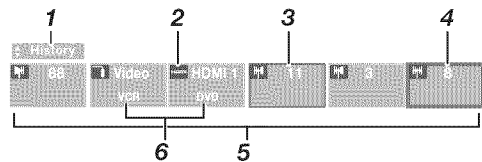

- 1 Current list (**History**, **ANT/CABLE**, **Inputs**, **Favorites**, or **REGZA-LINK**)
- 2 Input type
- 3 Channel or input currently being viewed
- 4 Channel or input that is currently highlighted in the browser
- 5 Channels stored in the current list
- 6 Inputs or channels labels

#### To toggle among the available lists:

- 1 Open the Channel Browser™.
- 2 Press ▲ or ▼.

#### Note:

- The **History List** opens by default. After selecting another list, the Channel Browser™ will open in the last selected list.
- If all lists are turned off, **[FAV]** will not display the Channel Browser™. If **Favorites List** is turned off, pressing **[FAV]** will not display the Favorites Browser.
- Pressing **[FAV]** opens the Channel Browser™ Favorites list regardless of the last selected list in the Channel Browser™.

#### To tune to a channel or input in Browse mode:

- 1 Highlight an item. The TV tunes to the channel or input.
- 2 Press **[EXIT]** to close the Channel Browser™.

#### To tune to a channel or input in Select mode:

- 1 Highlight the item you want to be tuned.
- 2 Press **[OK]**.
- 3 Press **[EXIT]** to close the Channel Browser™.

### Favorites Browser

You can quickly create a favorite channels/inputs list that is integrated into the Channel Browser™.

#### To add a favorite channel or input:

- 1 Tune to the channel or input.
- 2 Press and hold **[FAV]** for 3 seconds.

**Note:** Additions are added to the beginning of the Favorites list on the left side of the Channel Browser™.

#### To delete a favorite channel or input:

- 1 Press **[FAV]**. The Favorites Browser list appears.
- 2 Select a channel or input by pressing ◀ or ▶.
- 3 Press and hold **[100]** for 3 seconds.

### Adding and clearing channels and inputs in the History List

#### Adding channels to the History List:

As a channel or input is tuned, the Channel Browser™ adds it to the History List and displays it on the right side of the Channel Browser™.

Previously tuned channels and inputs shift to the left. Press ◀ to surf back through the previously tuned channels and inputs.

The Channel Browser™ stores these channels:

- Channels that are tuned using the numeric buttons on the remote control.
- Channels that are tuned for at least 5 seconds using **[100]** or **[101]**.

#### To clear channels from the History List:

- Reconfigure the **ANT/CABLE** input.
- Turn off the TV.



## Using Channel Return

You can switch between two channels without entering a channel number each time. This feature also works for external inputs.

- 1 Select the first channel you want to view.
- 2 Select a second channel using the Channel Number buttons (and the dash (100) button if needed).
- 3 Each time you press **CH RTN**, the TV switches back and forth between the last two channels that were tuned.

## Using SurfLock™

The SurfLock™ feature temporarily memorizes one channel to the **CH RTN** button, so you can return to it quickly, but one time only, from any other channel with **CH RTN**. This feature also works for external inputs.

To memorize a channel to the **CH RTN** button:

- 1 Tune the channel you want to program into the **CH RTN** button.
- 2 Press and hold **CH RTN** for about 2 seconds until the message “Memorized” appears. The channel has been programmed to the **CH RTN** button.
- 3 You can then change channels repeatedly, and when you press **CH RTN**, the memorized channel will be tuned.

After pressing **CH RTN** and then changing channels again, the memory is cleared and the button functions as Channel Return.

## Selecting the video input to view

To select the video input to view:

- 1 Press **INPUT** on the remote control or TV control panel.
- 2 Change the input:
  - Press 0–8.
  - Repeatedly press **▲** or **▼**. Press **OK**.
  - Repeatedly press **INPUT**.

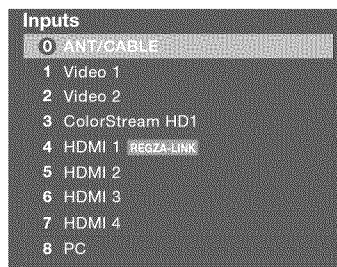

### Note:

- You can label the video input sources according to the specific devices you have connected to the TV (see “Labeling video inputs” on p. 30).
- You can skip sources (see “Skipping video inputs” on p. 29).
- Inputs that are set to skip will be not available and will be skipped over when selecting inputs by repeatedly pressing **INPUT** or **▲** or **▼**. They are only available by using direct number entry.
- If one or more REGZA-LINK® devices are connected to an HDMI input, the REGZA-LINK® icon appears in the input selector. In this case, the label (see p. 30) will not appear in the input selector.
- When the Auto Input feature is set, you can select a video input source in the remote control by pressing and holding the corresponding MODE SELECT button for 2 seconds (see p. 30).

To select a REGZA-LINK® device:

- 1 Press **▲** or **▼** to select a HDMI input.
- 2 Press **▶**. The list of REGZA-LINK® devices for that input appears.
- 3 If the input has multiple REGZA-LINK® devices, use **▲** or **▼** to select a device.
- 4 Press **OK**.

## Using closed captions

To turn on the closed caption mode:

- 1 **MENU** > **SETUP** > **TV Settings** > **OK**.
- 2 Press **▼** or **▲** to select **Closed Captions Settings**. Press **OK**.
- 3 Press **▼** or **▲** to select **Closed Captions**.
- 4 Press **◀** or **▶** to select **On**.

**Note:** If **Closed Captions** is set to **Off**, **Analog CC Mode** and **Digital CC Settings** will be not available.

## Analog CC mode

The closed caption mode has two options:

| Mode     | Description  |
|----------|--|
| Captions | Displays the dialogue, narration, and sound effects of TV programs and videos that are closed captioned (usually marked "CC" in program guides). |
| Text     | Displays information not related to the current program, such as weather or stock data (when provided by individual stations).                   |

To view captions or text:

- 1 **MENU** > **SETUP** > **TV Settings** > **OK**.
- 2 Press **▼** or **▲** to select **Closed Captions Settings**. Press **OK**.
- 3 Press **▼** or **▲** to select **Analog CC Mode**.
  - To view captions: Press **◀** or **▶** to highlight **CC1**, **CC2**, **CC3**, or **CC4**.



**Note:** If the program or video you selected is not closed captioned, no captions display.

- To view text: Press **◀** or **▶** to highlight **T1**, **T2**, **T3**, or **T4**.

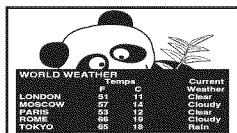

**Note:** If text is not available in your area, a black rectangle may appear on screen. You can set the **Closed Captions Settings** to **Off**.

**Note:** A closed caption signal may not display when a videotape is dubbed, signal reception is weak, or signal reception is non-standard.

## Digital CC settings

You can customize the closed caption display characteristics.

**Note:**

- This settings is available for digital channels only.
- You cannot set the **Caption Text** and **Background** as the same color.

| Mode                    | Description  |
|-------------------------|--|
| Caption Size            | Auto, Small, Standard, Large   |
| Caption Text Type       | Auto, Default, Mono w. Serif, Prop. w. Serif, Mono w/o Serif, Prop. w/o Serif, Casual, Cursive, Small Capitals |
| Caption Text Edge       | Auto, None, Raised, Depressed, Uniform, Left Drop Shadow, Right Drop shadow                                    |
| Caption Text Color      | Auto, Black, White, Red, Green, Blue, Yellow, Magenta, Cyan  |
| Text Foreground Opacity | Auto, Transparent, Translucent, Flashing, Solid  |
| Background Color        | Auto, Black, White, Red, Green, Blue, Yellow, Magenta, Cyan  |
| Text Background Opacity | Auto, Transparent, Translucent, Flashing, Solid  |
| Caption Text Edge Color | Auto, Black, White, Red, Green, Blue, Yellow, Magenta, Cyan  |

To customize the closed captions:

- 1 **MENU** > **SETUP** > **TV Settings** > **OK**.
- 2 Press **▼** or **▲** to select **Closed Captions Settings**. Press **OK**.
- 3 Press **▲** or **▼** to select **Digital CC Settings**. Press **OK**.
- 4 Press **▲** or **▼** to select a characteristic. Press **◀** or **▶** to select the format for that characteristic.

## Using the Closed Caption button

If you press **CC** when an analog channel is tuned or from an external input (480i signal from the video input):

- The CC bar will appear and will display CC1-4, T1-4, and Off as the options.

If you press **CC** when a digital channel is tuned:

- The CC bar will appear and will display the available caption options (available languages) for that channel or service.

## Setting the PIN code

A PIN code is necessary for some menus.

**Note:** *Parental Control and Locks* menu is grayed out if no PIN has been set.

### Entering a new PIN code

- 1 **MENU** > **PREFERENCES** > **PIN Setting** > **OK**.
- 2 Press the number buttons to enter a 4-digit number. Confirm the code.

**Note:** *PIN code cannot be set to "0000".*

### Changing or deleting your PIN code

- 1 **MENU** > **PREFERENCES** > **PIN Setting** > **OK**.
- 2 Press the number buttons to enter your 4-digit PIN code.
- 3 Select **Change PIN** or **Delete PIN**. Press **OK**.

**Note:**

- *PIN code cannot be set to "0000".*
- *If you delete the PIN code, the settings of **Parental Controls and Locks** are reset.*

### Forgotten PIN code

- 1 **MENU** > **PREFERENCES** > **PIN Setting** > **OK**.
- 2 Press **INFO** 4 times within 5 seconds. The code clears.
- 3 Enter a new PIN code.

## Using parental controls

### Blocking TV programs and movies by rating (V-Chip)

Some TV programs and movies include signals that classify the content of the program (violence, sex, dialogue, language). The V-Chip feature in this TV detects the signals and blocks the programs according to the ratings you select.

**Note:** *The V-Chip feature in this TV supports the U.S. V-Chip system only.*

- 1 **MENU** > **PREFERENCES** > **Parental Control and Locks** > **OK**.
- 2 Enter your 4-digit PIN code.
- 3 Press **▲** or **▼** to highlight **Enable Rating Blocking**.
- 4 Press **◀** or **▶** to select **On**.
- 5 Press **▼** to select **Edit Rating Limits**. Press **OK**. The **Edit Rating Limits** screen appears.
- 6 Press **▲**, **▼**, **◀** or **▶**.
- 7 Press **OK** to select a level of blocking. A box with an "X" indicates a rating that will be blocked. As you highlight a rating, the rating's definition appears at the bottom of the screen.

**Note:** *This feature will be not available if PIN code is not set.*

## Downloading an additional rating system

In the future, an additional rating system may become available for use in selectively blocking TV programs and movies.

**Note:** The currently tuned station must be receiving a digital signal before an additional rating system can be downloaded.

- 1 **MENU** > **PREFERENCES** > **Parental Control and Locks** > **OK**.
- 2 Enter your 4-digit PIN code. The **Parental Control and Locks** screen appears.
- 3 Press **▲** or **▼** to highlight **Enable Rating Blocking**.
- 4 Press **◀** or **▶** to select **On**.
- 5 Press **▼** to select **Edit Rating Limits**. Press **OK**. The **Edit Rating Limits** screen appears.
- 6 Select **Alt RS**. Press **OK**. The **Edit Alternate Ratings** screen appears.

**Note:**

- The **Alt RS** button is only available if an additional rating system is currently available.
- The download may require several minutes.
- The information displayed in the **Alternate Ratings** screen depends on the configuration of the additional rating system available at the time of download.

- 7 Press **▲**, **▼**, **◀** or **▶**.
- 8 Press **OK** to select a level of blocking. A box with an "X" indicates a rating that will be blocked.

**Note:**

- You can only download the additional rating system once. You cannot download updates if they become available.
- The additional rating system is not designed, transmitted, or controlled by the TV or Toshiba, nor is the availability of an additional rating system determined or controlled by Toshiba. Similarly, the rating of programs in an additional rating system is not determined, transmitted, or controlled by the TV or Toshiba.
- The additional rating system is an evolving technology; therefore, availability, content, and format may vary.

## Rating system

| Independent rating system for broadcasters |  |
|--|--|
| Ratings                                    | Description and Content themes   |
| TV-MA                                      | Mature Audience Only (This program is specifically designed to be viewed by adults and therefore may be unsuitable for children under 17.)<br><b>L</b> ) Crude or indecent language <b>S</b> ) Explicit sexual activity <b>V</b> ) Graphic violence  |
| TV-14                                      | Parents Strongly Cautioned (This program contains some material that many parents would find unsuitable for children under 14 years of age.)<br><b>D</b> ) Intensely suggestive dialogue <b>L</b> ) Strong, coarse language <b>S</b> ) Intense sexual situations <b>V</b> ) Intense violence |
| TV-PG                                      | Parental Guidance Suggested (This program contains material parents may find unsuitable for younger children.)<br><b>D</b> ) Some suggestive dialogue <b>L</b> ) Infrequent coarse language <b>S</b> ) Some sexual situations <b>V</b> ) Moderate violence                                   |
| TV-G                                       | General Audience (Most parents would find this program suitable for all ages.)   |
| TV-Y7, TV-Y7FV                             | Directed to Older Children (This program is designed for children age 7 and above. Note: Programs in which fantasy violence may be more intense or more combative than other programs in this category are designated TV-Y7FV.)  |
| TV-Y                                       | All Children (This program is designed to be appropriate for all children.)  |

| Independent rating system for movies |   |
|--------------------------------------|---|
| Ratings                              | Description and Content themes  |
| X                                    | X-rated (For adults only)   |
| NC-17                                | Not intended for anyone 17 and under  |
| R                                    | Restricted (Under 17 requires accompanying parent or adult)                           |
| PG-13                                | Parents Strongly Cautioned (Some material may be inappropriate for children under 13) |
| PG                                   | Parental Guidance Suggested (Some material may not be suitable for children)          |
| G                                    | General Audience (Appropriate for all ages)   |

**Note:**

- If you place an "X" in the box next to "Rated None", programs rated "None" or "Not Rated" will be blocked; Programs that do not provide any rating information will not be blocked.

## Displaying ratings

To display the rating of the program you are watching, press **INFO** on the remote control.

| Indication in the INFO screen | Description                        |
|-------------------------------|------------------------------------|
| NONE                          | The program is rated None.         |
| (No rating appears)           | No rating information is provided. |

## Unlocking programs

If you try to tune the TV to a program that exceeds the rating limits you set, the TV will enter program lock mode and a warning message will appear onscreen. Follow the instructions to temporarily unlock the program.

## Locking specific channels

A channel that is configured as Locked cannot be viewed unless the PIN code is entered first (see "Setting the PIN code" on p. 35).

- 1 **MENU** > **SETUP** > **TV Settings** > **OK**.
- 2 Press **▲** or **▼** to select **Channel Options**. Press **OK**. The list of channels appears.

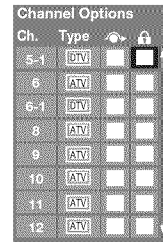

- 3 Press **▶** and then **▲** or **▼** to select a channel in the lock column, then press **OK**.
- 4 You must enter your PIN code to access locked channels.  
*Note: If the PIN code is not yet set, a warning appears.*
- 5 The box is selected. To clear the selection, press **OK**.

## Locking video input







You can lock video inputs and channels 3 and 4. You cannot view the input sources or channels until you unlock the inputs by entering the PIN code.

- 1 **MENU** > **PREFERENCES** > **Parental Control and Locks** > **OK**.
- 2 Enter your 4-digit PIN code.
- 3 Press **▲** or **▼** to highlight **Input Lock**.
- 4 Press **◀** or **▶** to select **Video**, **Video+** or **Off**.

| Mode   | Description   |
|--------|---|
| Video  | Locks Video 1, Video 2, ColorStream HD1, ColorStream HD2, HDMI 1, HDMI 2, HDMI 3, HDMI 4 and PC.  |
| Video+ | Locks Video 1, Video 2, ColorStream HD1, ColorStream HD2, HDMI 1, HDMI 2, HDMI 3, HDMI 4, PC and channels 3 and 4.<br>• Select <b>Video+</b> if you play video tapes via the ANT/CABLE input. |
| Off    | Unlocks all video inputs and channels 3 and 4.  |

## Setting a time limit for games

You can use the GameTimer® to set a time limit for playing a video game. When the time expires, the TV locks all external inputs.

- 1  > **PREFERENCES** > **Parental Control and Locks** > .
- 2 Enter your 4-digit PIN code.
- 3 Press  or  to select **GameTimer**.
- 4 Press  or  to select **30**, **60**, **90**, or **120** minutes.
- 5 To cancel the timer, select **Off**.

To deactivate the Input Lock once the GameTimer® has activated it:







Set the **Input Lock** to **Off** ( “Locking video input” on p. 37).

### Note:

- A message appears when 10 minutes, 3 minutes, and 1 minute remain.
- If the TV loses power with time remaining, the TV will enter Input Lock mode when power is restored (as if the GameTimer had been activated). You must deactivate the Input Lock ( “Locking video input”).

## Locking the control panel

You can lock the control panel to prevent your settings from being changed accidentally (by children, for example). When **Panel Lock** is set to **On**, none of the controls on the control panel operate except **POWER**.

- 1  > **PREFERENCES** > **Parental Control and Locks** > .
- 2 Enter your 4-digit PIN code.
- 3 Press  or  to select **Panel Lock**.
- 4 Press  or  to select **On**.

**Note:** When **Panel Lock** is set to **On**, “Not Available” screen appears when the buttons on the TV control panel are pressed. If the **POWER** button is pressed, the TV turns off and you must use the remote control to turn it on.

To unlock the control panel:

Select **Off** in step 4 above.

## Using REGZA-LINK®











This feature uses CEC technology and allows you to control Toshiba REGZA-LINK® compatible devices from the TV remote control via HDMI connection. When **Enable REGZA-LINK** in the **REGZA-LINK Setup** menu is set to **On**, the following REGZA-LINK® functions are enabled.

## Controlling REGZA-LINK® playback devices

With your TV’s remote control, you can control the connected REGZA-LINK playback device (DVD player, etc.) you are watching.

### Available remote control key functions:

Before using these key functions, set the MODE SELECT switch on the remote control to **TV**.

| Button  | Description                                    |
|---|--|
|    | Begins playback.                               |
|    | Stops playback.                                |
|    | Pauses the picture during play or record mode. |
|    | Skips forward.                                 |
|    | Skips backward.                                |
|   | Fast-forwards.                                 |
|  | Rewinds / reverses.                            |
|  | Navigates contents menu, etc.                  |
|  | Enters contents menu, etc.                     |
|  | Returns to the previous menu.                  |
|  | Closes the menu.                               |
| RED,<br>GREEN,<br>YELLOW,<br>BLUE   | Controls various operations                    |

**Note:** These functions depend on the connected devices.

REGZA-LINK® Player Control menu functions:

- 1 Press **QUICK** to open the Quick menu.
- 2 Select **REGZA-LINK Player Control**. Press **OK**.
- 3 Press **▲** or **▼** to select the item you want to control and press **OK**.

| Item          | Description   |
|---------------|---|
| Power         | Turns the selected device on and off.                 |
| Root Menu     | Accesses the selected device's top menu.              |
| Contents Menu | Accesses the contents list when you press <b>OK</b> . |
| Setup Menu    | Accesses the DVD player's setup menu.                 |
| Top Menu      | Accesses the DVD's top menu during playback.          |
| DVD Menu      | Accesses the DVD's menu during playback.              |

**Note:**

- These functions depend on the connected devices.
- The **REGZA-LINK Player Control** item is not available under these conditions:
  - A non-HDMI input is selected.
  - The **Enable REGZA-LINK** item is set to **Off**.
  - The connected REGZA-LINK device is not a playback or recording device.

## REGZA-LINK® input source selection

If a REGZA-LINK® device with HDMI switching capability (e.g. an amplifier) is connected to the HDMI input, you can select another REGZA-LINK® device that is connected to the master HDMI device. Use **INPUT** on the remote control or the control panel (p. 33).

## Adjusting the amplifier's audio

Using the TV's remote control, you can adjust or mute the sound volume of your amplifier. First, set the MODE SELECT switch on the remote control to **TV**.

- **VOL** adjust the volume level.
- **MUTE** turns off the sound.

1 **MENU** > **PREFERENCES** > **REGZA-LINK Setup** > **OK**.

2 Press **▲** or **▼** to highlight **Speaker Preference**.

3 Press **◀** or **▶** to select **Amplifier**.

**Note:** Confirm that a connected REGZA-LINK® device (such as DVD player, etc.) is selected for the Amplifier input source.

**Note:**

- You can also use this function when the amplifier is connected to the TV's **DIGITAL AUDIO OUT** terminal (not HDMI connection). Select a digital audio input mode on the amplifier.
- These functions depend on the device connected.

## Other REGZA-LINK® functions

When **Enable REGZA-LINK** and all items in the **REGZA-LINK Setup** menu are set to **On**, the following functions will be enabled.

| Item               | Description  |
|--------------------|--|
| TV Auto Power      | If a REGZA-LINK® device is turned on, the TV turns on automatically.   |
| Auto Standby       | If the TV is turned off, the TV will send a message to turn off all of the REGZA-LINK devices connected to the TV.   |
| Amplifier Control  | If Amplifier Control is set to <b>On</b> , you can adjust the sound volume or turn off the sound using the remote control.   |
| Speaker Preference | From this item, you can set your audio output preference to the TV speakers or the amplifier. When this item is set to <b>Amplifier</b> , the remote control can be used to adjust or mute the volume of the audio. This item will be not available and set to <b>TV Speakers</b> automatically unless a REGZA-LINK® compatible audio receiver is connected. |

**Note:** When you turn on the amplifier, change its input source, or adjust the sound volume, the sound will be output from the amplifier's speakers even if **TV Speakers** has been selected. Turn the TV off and on again to output the sound from the TV speakers.

To set the REGZA-LINK® Setup:

- 1 **MENU** > **PREFERENCES** > **REGZA-LINK Setup** > **OK**.
- 2 Press **▲** or **▼** to highlight **Enable REGZA-LINK**.
- 3 Press **◀** or **▶** to select **On**.  
**Note:** If you set **Enable REGZA-LINK** to **Off**, the other items under **REGZA-LINK Setup** will be grayed out.
- 4 Press **▲** or **▼** to select a **REGZA-LINK** setup item. Press **◀** or **▶** to select **On** or the desired mode.
  - TV Auto Power: On/Off
  - Auto Standby: On/Off
  - Amplifier Control: On/Off
  - Speaker Preference: TV Speakers/ Amplifier

## Connecting a Toshiba PC compatible to REGZA-LINK®

This feature automatically sets suitable widescreen formats and picture preferences when the TV is connected to a Toshiba PC compatible with REGZA-LINK®.

**Note:** This feature depends on the equipment connected.

## Using the HDMI® settings feature

**Note:** If some HDMI legacy sources do not work properly with your HDMI TV, set the following options (Content Type and INSTAPORT™) to **Off**. Adjusting these settings should allow your HDMI legacy source to operate properly with your TV.

| Mode (default setting)  | Description   |
|-------------------------|---|
| Enable Content Type: On | Adjusts the picture quality automatically by the content of "Contents type" included in the HDMI input.<br><b>Note:</b> When Picture Mode is set to <b>AutoView</b> , this feature is available.                                |
| INSTAPORT™: On          | Reduces the lag time when switching HDMI sources.   |
| RGB Range: Auto         | Adjusts RGB full range signal automatically.<br>When <b>Limited</b> is selected, RGB output signal is output in the range from 16 to 235. When <b>Full</b> is selected, RGB output signal is output in the range from 0 to 255. |

The HDMI settings (Content Type and RGB Range) need proper HDMI source devices. If your HDMI source device does not support these features, the TV may not work properly when these features are enabled.

**Note:** If your HDMI connection is capable of 1080p and/or your TV is capable of refresh rates greater than 60 Hz, you will need a High Speed HDMI® cable. Conventional HDMI/DVI cables may not work properly with this mode.

- 1 Select the appropriate HDMI input mode (HDMI 1, HDMI 2, HDMI 3, or HDMI 4).
- 2 **MENU** > **PREFERENCES** > **AV Connection** > **OK**.
- 3 Press **▲** or **▼** to select **HDMI Settings**.
- 4 Press **▲** or **▼** to select an item.
- 5 Press **◀** or **▶** to select a setting.



## Setting the HDMI® audio mode

- 1 **MENU** > **PREFERENCES** > **AV Connection** > **OK**.
- 2 Press **▲** or **▼** to select **HDMI 3 Audio** or **HDMI 4 Audio**.
- 3 Press **◀** or **▶** to select **Auto**, **Digital** or **Analog**.

| Mode    | Description   |
|---------|---|
| Auto    | When viewing the HDMI 3 input or HDMI 4 input, if digital audio from the HDMI input is available, it will be output. If not, the TV detects and outputs analog audio from each Audio input. |
| Digital | When viewing the HDMI 3 input or HDMI 4 input, digital audio from the HDMI input will be output.  |
| Analog  | When viewing the HDMI 3 input or HDMI 4 input, analog audio from each input will be output.   |

### Note:

- **HDMI 3 Audio** is set to **Digital** when **Rear Shared Audio** is set to **ColorStream HD1** or **Video 1** (p. 30).
- **HDMI 4 Audio** is set to **Digital** when **Side Shared Audio** is set to **PC** or **ColorStream HD2** (p. 30).

## Viewing the HDMI® signal information

- 1 **MENU** > **PREFERENCES** > **HDMI Information Display**.
- 2 Press **◀** or **▶** to select **On**. Press **INFO**. Normal banner and signal information banner appears.

### Note:

- Signal information banner will appear when this feature is set to **On** and you watch HDMI input.
- If you press **INFO** when this feature is set to **Off**, only normal banner will appear.
- When Content type is No Data, this is not displayed.

## Using your PC with the TV

### Adjusting the image

If the edges of the picture are hidden, readjust the **Horizontal Position** and **Vertical Position**. If the picture is affected by interference, readjust the **Clock Phase** and **Sampling Clock**.

- 1 Select PC input mode (p. 33) “Selecting the video input to view” on p. 33).
- 2 **MENU** > **PREFERENCES** > **Display Settings** > **OK**.
- 3 Press **▲** or **▼** to select **PC Settings**. Press **OK**.  
**Note:** If a PC is not connected or there is no PC input signal, this menu will be not available.
- 4 Press **▲** or **▼** to select the item.
- 5 Press **◀** or **▶** to make adjustments.

**Note:** The screen is disrupted momentarily when adjusting the PC settings. This is not a sign of malfunction.

| Mode                | Description   | Adjustment range              |
|---------------------|---|-------------------------------|
| Horizontal Position | Moves the picture left/right.   | within $\pm 10$ from center.* |
| Vertical Position   | Moves the picture up/down.  | within $\pm 10$ from center.* |
| Clock Phase         | Helps to reduce noise and sharpen the picture.                              | within $\pm 15$ from center.  |
| Sampling Clock      | Helps to reduce noise and minimize periodic vertical stripes on the screen. | within $\pm 5$ from center.   |

\* The default settings and /or adjustment ranges vary depending on the input signal format.

### To reset PC Settings:

Select **Reset**. Press **OK**.

## Setting the PC audio

You can output sound from your PC when connecting using the AUDIO IN terminal and PC audio cable.

- 1 **MENU** > **PREFERENCES** > **AV Connection** > **OK**.
- 2 Press **▲** or **▼** to select **Side Shared Audio**.
- 3 Press **◀** or **▶** to select **PC**.

### Note:

- To select PC, set **Shared PC Input** to **PC**.
- Setting **Side Shared Audio** to **PC** forces **HDMI 4 Audio** to **Digital** mode.

## Setting the timer to turn on the TV

You can set the on timer to turn on the TV to a preset channel or input at a preset time.

To activate the timer:

- 1 **MENU** > **APPLICATIONS** > **On Timer** > **OK**.
- 2 Press **▲** or **▼** to select **Enable On Timer**.
- 3 Press **◀** or **▶** to select **On**.

**Note:** If the Enable On Timer is set to **Off**, other menus under On Timer cannot be changed.

To set the timer:

- 1 **MENU** > **APPLICATIONS** > **On Timer** > **OK**.
- 2 Set these options to your preferences:

| Item                | Description   |
|---------------------|---|
| On Timer LED        | A state of On Timer LED while On Timer is set to On.<br><b>On:</b> Turns on the LED.<br><b>Off:</b> Turns off the LED.                                      |
| Input               | Video input source.   |
| Channel             | Channel to view.  |
| Volume              | Volume level.   |
| Time until Power On | Amount of time from now when you want the TV to turn on.<br>minimum= 00:10, maximum= 12:00<br>• Press <b>◀</b> or <b>▶</b> .<br>• Press the number buttons. |

- 3 Select **Done**. Press **OK**.

**Note:**

- When the On Timer LED is set to On, the LED lights to green (☞ "LED indications" on p. 78).
- If you do not operate the TV for 1 hour after it is powered on by the On Timer feature, the TV turns off.

To cancel the timer:

- 1 **MENU** > **APPLICATIONS** > **On Timer** > **OK**.
- 2 Press **▲** or **▼** to select **Enable On Timer**.
- 3 Press **◀** or **▶** to select **Off**.

## Setting the sleep timer

You can set the TV to turn off after a specific amount of time (maximum = 12 hours).

Using the remote control:

- 1 Press **SLEEP**.
- 2 Set the time until the TV turns off.
  - Repeatedly press **SLEEP** to increase the time.
  - Press **▲** or **▼** to increase or decrease the time.

Using the onscreen menus:

- 1 **MENU** > **APPLICATIONS** > **Sleep Timer**.
- 2 Enter the time until the TV turns off.
  - Press the number buttons.
  - Press **▲** or **▼** to increase or decrease the time.

**Note:** When a power failure occurs, the sleep timer setting may be cleared.

To display the time remaining until the TV turns off:  
Press **SLEEP**.

To cancel the sleep timer:

Press **SLEEP** repeatedly or press **▲** or **▼** until it is set to 0 minutes.

## Setting Automatic Power Down

The TV can be configured to automatically turn itself off after 4 hours, if you do not operate the TV either from the remote control or the TV control panel.

- 1 **MENU** > **PREFERENCES** > **Energy Saving Settings**  
> **OK**.
- 2 Press **▲** or **▼** to select **Automatic Power Down**.
- 3 Press **◀** or **▶** to select **On**. Press **EXIT**.

### Note:

- 1 minute before switching to standby, a warning message will appear.
- When the following features are set, the feature that is set for the nearest time will function.
  - Automatic Power Down
  - Sleep Timer
  - Photo Frame/Auto Power Off
  - Auto shutdown after 1 hour of inactivity (after power-on by On Timer)
  - No signal auto power off (after 15 minute of no signal)

## Setting No Signal Power Down

The TV will automatically turn itself off after 15 minutes when no signal is detected.

You can change each input's setting to Off: ANT/CABLE, Video 1, Video 2, ColorStream HD1, ColorStream HD2, HDMI 1, HDMI 2, HDMI 3, HDMI 4, PC

- 1 **MENU** > **PREFERENCES** > **Energy Saving Settings**.  
Press **OK**.
- 2 Press **▲** or **▼** to select **No Signal Power Down**.  
Press **OK**.
- 3 Press **▲** or **▼** to highlight the item you want to change.
- 4 Press **◀** or **▶** to select **Off**. Press **EXIT**.

### Note:

- Default setting for each input is **On**.
- A warning message will appear 1 minute before turning off.

## Setting Blue Screen

When Blue Screen is set to On, the screen will turn blue and the sound will be muted when no signal is received.

- 1 **MENU** > **PREFERENCES** > **Blue Screen**.
- 2 Press **◀** or **▶** to select **On**. Press **EXIT**.

*Note:* Some external inputs may not mute the sound.

## Adjusting POWER LED's Dimmer

You can turn down the POWER LED's brightness.

- 1 **MENU** > **PREFERENCES** > **POWER LED Dimmer**.
- 2 Press **◀** or **▶** to select **On**. Press **EXIT**.

## Displaying TV status information

To display TV status information:

Press **INFO**.

The following information will display (if applicable):

- Current input (**ANT/CABLE**, **Video**, etc.)
- If ANT/CABLE is the current input, either “CABLE” (for cable TV) or “ANT” (for over-the-air broadcasts).
- Channel number (if in **ANT/CABLE** mode)
- Input label (if set)
- Digital signal strength indicator (bar graph in lower right corner of box; for ATSC signal only)
- Stereo, Mono or SAP audio status (when HDMI input mode, PCM)
- Video resolution
- Aspect ratio of incoming video signal (4:3 or 16:9)
- V-Chip rating status
- GameTimer (if set)

To close the screen:

Press **INFO** again.

The following additional information (only available for **ANT/CABLE** input) will display for off air digital channels (if applicable):

- Title
- Duration
- Detailed description

To display next program information for digital channels, press **INFO** again. Pressing **INFO** a third time will remove the entire banner.



**Note:** The location of the banner can be moved to the top or bottom of the screen by pressing **▲** or **▼** while the **INFO** display is onscreen. The last position will be stored to memory.

## Viewing support information

- 1 **MENU** > **SETUP** > **System Information**.
- 2 Press **OK** to display support information containing Web/Customer service numbers for US, Canada and Mexico.

## Resetting to Factory Defaults

You can reset all settings and channels.

**Note:** By upgrading, the factory default values may be changed.

- 1 **MENU** > **SETUP** > **Reset TV** > **OK**.
- 2 Enter your PIN code (if PIN code has been set).
- 3 A confirmation screen appears. Select **Yes**, and press **OK**. The TV will turn off automatically.

To cancel the reset:

Press **◀** or **▶** to select **No**. Press **OK**.

## Power failure

If the power is cut off while you are viewing the TV, the Last Mode Memory feature automatically turns on the TV when the power is restored.

# Chapter 7: Picture and sound controls

## Selecting the picture size

You can view many program formats in several picture sizes—**Native**, **4:3**, **Full**, **TheaterWide 1**, **TheaterWide 2**, **TheaterWide 3**, **Normal**, and **Dot by Dot**.

**Note:** The picture size illustrations are examples only. The format of the image (in any of the picture sizes) depends on the format of the signal you are currently watching. Select the picture size that displays the current program the way that looks best to you.

You can save separate picture size preferences for each input on your TV.

To select the picture size:

- 1 Press **PIC SIZE**.
- 2 While the **Picture Size** screen is open, do one of the following:
  - Repeatedly press **PIC SIZE**.
  - Press the corresponding number button.
  - Press **▲** or **▼** and **OK**.

**Note:** Some picture sizes may not be available depending on the signal format being received.

Using these functions to change the picture size (i.e., changing the height/ width ratio) for any purpose other than your private viewing may be prohibited under the Copyright Laws of the United States and other countries, and may subject you to civil and criminal liability.

**Note:** If you select a TheaterWide® picture size, the top and bottom edges of the picture (including subtitles or captions) may be hidden. To view these edges, adjust the **Picture Position** (↕ "Scrolling the picture" on p. 47) or try viewing the program in **4:3** or **Full**.

Picture Size

**Native**  
(for 480i (HDMI), 480p (HDMI), 720p, 1080i, and 1080p signal programs)

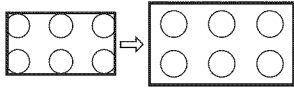

- If receiving a 1080i, 1080p, 720p, 480i (HDMI), or 480p (HDMI) signal program, the video is scaled to display the entire picture within the borders of the screen (i.e. no overscanning).
- This is especially useful for external HD sources such as DVHS movies, Video Games or PC graphics.
- None of the picture is hidden.

**Note:**

- This mode is supported only for HDMI (1080i, 1080p, 720p, 480i, and 480p), ColorStream® (1080i and 720p), and ANT/CABLE (digital) inputs (1080i, 1080p, and 720p).
- Depending on the input signal, the picture's border may be hidden, displayed in black, or noisy.

**4:3**

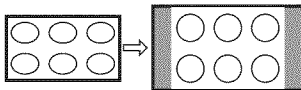
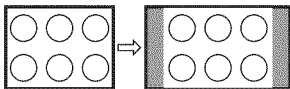

Some program formats will display with sidebars and/or bars at the top and bottom.

**Full**  
(for 16:9 [480i, 480p] source programs only)

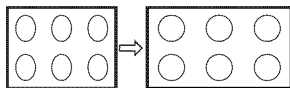

If receiving a squeezed 4:3 format program, the picture is stretched wider to fill the width of the screen but not stretched taller.

(for 1080i, 1080p, and 720p program sources)

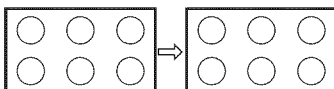

The edges of the picture may be hidden.

Picture Size

**TheaterWide 1**  
(for 4:3 format programs)

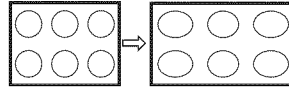

The center of the picture remains close to its original proportion, but the left and right edges are stretched wider to fill the screen.

**TheaterWide 2**  
(for letter box programs)

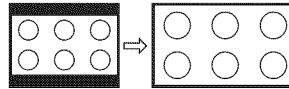

The picture's top and bottom edges may be hidden\*.

**TheaterWide 3**  
(for letter box programs with subtitles)

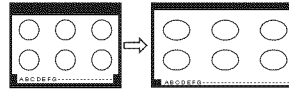

The picture's top and bottom edges are hidden\*.

**Normal**  
(for VGA, SVGA, XGA, WXGA, and SXGA sources and Photo files)

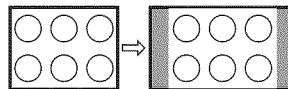

This size is a non-stretched display. Some input signal formats will display with sidebars and/or bars at the top and bottom.

**Dot by Dot**  
(for VGA, SVGA, XGA, WXGA, and SXGA sources and Photo files)

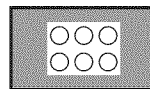

"Dot by Dot" is a non-scaling display. Depending on the input signal format, the picture is displayed with sidebars and/or bars at the top and bottom. (Example: VGA input source)

\* To view the hidden areas (such as subtitles or captions), see "Scrolling the picture" (p. 47).

## Scrolling the picture

If the edges of the picture are hidden, you can adjust the image's position.

**Note:** You can adjust the picture position when the picture size is set to **TheaterWide 2** or **TheaterWide 3**.

- 1 **MENU** > **PREFERENCES** > **Display Settings** > **OK**.
- 2 Press **▲** or **▼** to select **Picture Position**. Press **OK**.
- 3 Press **▲** or **▼** to select **Vertical Position**.
- 4 Press **◀** or **▶** to make the appropriate adjustments. The adjustment range is from **-5** to **+10**.

## Using the Auto Aspect feature

When this feature is set to **On**, the TV will automatically select the picture size when one of the following input sources is received:

- A 480i, 480p, 720p, 1080i digital signal from the **ANT/CABLE** input
- A 480i signal from the **ColorStream HD** or **Video** input
- A 480i, 480p, 720p, 1080i, 1080p, or VGA (60/72/75 Hz) signal from the **HDMI 1/2/3/4** input

**Note:** The auto aspect ratio feature is not applicable to the **PC** input.

- 1 **MENU** > **PREFERENCES** > **Display Settings** > **OK**.
- 2 Press **▲** or **▼** to select **Auto Aspect**.
- 3 Press **◀** or **▶** to select **On**. Press **EXIT**.

## Using the 4:3 Stretch

When 4:3 Stretch is activated, the TV displays 4:3 programs as full-screen picture.

**Note:** This feature is available when **Auto Aspect** is set to **On**.

- 1 **MENU** > **PREFERENCES** > **Display Settings** > **OK**.
- 2 Press **▲** or **▼** to select **4:3 Stretch**.
- 3 Press **◀** or **▶** to select **On**. Press **EXIT**.

## Freezing the picture

- 1 When viewing the TV, press **FREEZE** to make the picture a still picture.
- 2 To return to a moving picture, press **FREEZE** again.

**Note:**

- After 15 minutes, the TV returns to a moving picture.
- When **NET TV** feature is used, this is not available.

Using the **FREEZE** function for any purpose other than your private viewing may be prohibited under the Copyright Laws of the United States and other countries, and may subject you to civil and criminal liability.

## Adjusting the picture

### Selecting the picture mode

You can select your desired picture settings from the following modes, as described below.

| Mode      | Description   |
|-----------|---|
| AutoView™ | Automatically adjusts picture settings based on ambient light conditions and input signal content.                        |
| Sports    | Bright and dynamic picture.   |
| Standard  | Standard picture settings.  |
| Movie 1   | Lower contrast for darkened room.   |
| Movie 2   |   |
| Game      | Designed for playing a video game requiring split-second timing between the screen display and input from the controller. |
| PC        | Designed for viewing of PC tables and documents.  |

**Note:**

- **PC** mode is available for HDMI and PC inputs only (not displayed for other input sources).
- **Game** mode cannot be turned on when the **ANT/CABLE** input is selected.

1 **[MENU]** > **PICTURE** > **Picture Mode**.

2 Press **◀** or **▶** to select a mode. Press **[EXIT]**.

**Note:** The picture mode you select affects the current input only. You can select a different picture mode for each input.

### Adjusting the picture quality

The picture quality you adjusted under the picture mode is saved to the picture mode of same name.

| Selection  | Pressing <b>◀</b> | Pressing <b>▶</b> |
|------------|-------------------|-------------------|
| Backlight* | darker            | lighter           |
| Contrast   | lower             | higher            |
| Brightness | darker            | lighter           |
| Color      | paler             | deeper            |
| Tint       | reddish           | greenish          |
| Sharpness  | softer            | sharper           |

\* Backlight: Adjusts the brightness of the entire screen. When in video mode and no signal is input, this selection is set to 0. (Settings are stored in memory.)

**Note:** Some menus cannot be adjusted in any of the following cases.

- **AutoView** is selected.
- **TheaterLock** is set to **On**.

#### To adjust the picture quality:

1 **[MENU]** > **PICTURE** > the setting you would like to adjust (**Backlight**, **Contrast**, **Brightness**, **Color**, **Tint**, or **Sharpness**).

2 Press **◀** or **▶** to adjust the setting. Press **[EXIT]**.

**Note:** The picture setting that you adjusted affects the current input only. You can adjust the picture quality separately for each input.

#### To reset to the factory defaults:

1 Select the picture mode you want to reset.

2 **[MENU]** > **PICTURE** > **Reset** > **[OK]**. A confirmation screen appears.

3 Press **◀** or **▶** to select **Yes**. Press **[OK]**.



## Using the advanced picture settings features

**Note:** Some of the Advanced Picture Settings features will not be available for adjustment when the Picture Mode is set to **AutoView**.

### Resolution+™

The Resolution+™ feature lets you adjust the levels for your desired picture settings and achieve a sharper picture.

To set Resolution+:

- 1 **MENU** > **PICTURE** > **Advanced Picture Settings** > **OK**.
- 2 Press **▲** or **▼** to select **Resolution+**. Press **OK**.
- 3 Press **◀** or **▶** to select **On**.
- 4 Press **▲** or **▼** to highlight **Level**. Press **◀** or **▶** to select either **1**, **2**, **3**, **4**, or **5** and press **OK**.

**Note:**

- When the Picture Mode is set to **AutoView**, the level range is from -2 to +2.
- If the Picture Mode is set to **Game** or **PC**, Resolution+ is not available.
- This feature may not work properly depending on the content.
- Noise may appear on the image depending on the device connected to the TV (e.g. a device with a specific enhancer function).

### Dynamic Contrast

Dynamic Contrast detects changes in picture quality that affect the appearance of your contrast settings and then automatically adjusts the video.

- 1 **MENU** > **PICTURE** > **Advanced Picture Settings** > **OK**.
- 2 Press **▲** or **▼** to select **Dynamic Contrast**.
- 3 Press **◀** or **▶** to adjust the level. Press **OK**. The adjustment range is from **0** to **10**.

**Note:** When the Picture Mode is set to **AutoView**, the level range is from -5 to +5.

### DynaLight™

The DynaLight™ feature automatically strengthens the black coloring of dark areas in the video according to the level of darkness.

- 1 **MENU** > **PICTURE** > **Advanced Picture Settings** > **OK**.
- 2 Press **▲** or **▼** to select **DynaLight**.
- 3 Press **◀** or **▶** to select **On** or **Off**. Press **EXIT**.

### Static Gamma

The static gamma feature lets you adjust the levels of black in the picture.

To adjust the static gamma settings:

- 1 **MENU** > **PICTURE** > **Advanced Picture Settings** > **OK**.
- 2 Press **▲** or **▼** to select **Static Gamma**.
- 3 Press **◀** or **▶** to adjust the level. Press **OK**. The adjustment range is within  $\pm 15$  from center.

### Film Stabilization

This feature helps to eliminate video shaking.

- 1 **MENU** > **PICTURE** > **Advanced Picture Settings** > **OK**.
- 2 Press **▲** or **▼** to select **Film Stabilization**.
- 3 Press **◀** or **▶** to select **Smooth**, **Standard** or **Off**. Press **EXIT**.

**Note:**

- If the Picture Mode is set to **Game** or **PC**, this feature will be set to **Off** automatically and grayed out.
- If the Picture Mode is set to **AutoView**, select **Auto**, **Smooth**, **Standard** or **Off**.

### ClearFrame 120™ feature

The ClearFrame 120 Hz anti-blur technology doubles the frame rate from 60 frames per second to 120 frames per second, virtually eliminating motion blur without adding flicker or reducing image brightness.

- 1 **MENU** > **PICTURE** > **Advanced Picture Settings** > **OK**.
- 2 Press **▲** or **▼** to select **ClearFrame 120**.
- 3 Press **◀** or **▶** to select **On**. Press **EXIT**.

**Note:** If the Picture Mode is set to **Game**, this feature is not available.

## MPEG NR

The MPEG noise reduction feature allows you to reduce visible interference caused by MPEG compression.

- 1 **MENU** > **PICTURE** > **Advanced Picture Settings** > **OK**.
- 2 Press **▲** or **▼** to select **Noise Reduction**. Press **OK**.
- 3 Press **▲** or **▼** to highlight **MPEG NR**.
- 4 Press **◀** or **▶** to select either **Low**, **Middle**, **High** or **Off**. Press **OK**.

**Note:** If the Picture Mode is set to **Game** or **PC**, this feature is not available.

## DNR

DNR lets you soften the screen representation of a weak signal to reduce the noise effect.

- 1 **MENU** > **PICTURE** > **Advanced Picture Settings** > **OK**.
- 2 Press **▲** or **▼** to select **Noise Reduction**. Press **OK**.
- 3 Press **▲** or **▼** to select **DNR**.
- 4 Press **◀** or **▶** to select **Low**, **Middle**, **High**, **Auto** or **Off**. Press **OK**.

**Note:**

- If the Picture Mode is set to **Game** or **PC**, this feature is not available.
- The differences may not always be noticeable. For the best result, use lower settings, as picture quality can be lost if the setting is too high.

## Smart Sensor

When the Auto Brightness function of Smart Sensor is set to **On**, the TV optimizes the backlighting levels to suit ambient light conditions.

- 1 **MENU** > **PICTURE** > **Advanced Picture Settings** > **OK**.
- 2 Press **▲** or **▼** to select **Smart Sensor Settings**. Press **OK**.
- 3 Press **▲** or **▼** to select **Auto Brightness Setting**.
- 4 Press **◀** or **▶** to select **On** or **Off**. Press **OK**.

**Note:** When the Picture Mode is set to **AutoView**, this feature is automatically set to **On** and will be not available.

## Backlight Adjustment Pro

This feature adjusts the backlight so that it can change to match the ambient light conditions.

- 1 **MENU** > **PICTURE** > **Advanced Picture Settings** > **OK**.
- 2 Press **▲** or **▼** to select **Smart Sensor Settings**. Press **OK**.
- 3 Press **▲** or **▼** to select **Backlight Adjustment Pro**. Press **OK**. The Backlight Control Level screen appears.
- 4 Press **OK** to display the adjustment window. Press **◀** or **▶** to select the point. Press **▲** or **▼** to adjust the level. The adjustment range is from **0** to **100**.

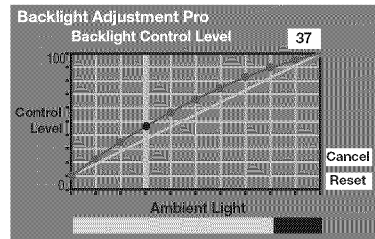

- 5 Press **OK** to fix the adjustment. To cancel the adjustment when selecting a point, select **Cancel** on the screen. To reset the adjustments of all points to the factory defaults, select **Reset** on the screen. Press **OK**.

**Note:** If the **Auto Brightness Setting** is set to **Off**, this feature will be not available.

## Room Lighting

This feature adjusts the picture color according to the room lighting.

**Note:** When Picture Mode is set to **AutoView**, this feature will be available.

- 1 **MENU** > **PICTURE** > **Advanced Picture Settings** > **OK**.
- 2 Press **▲** or **▼** to select **Smart Sensor Settings**. Press **OK**.
- 3 Press **▲** or **▼** to select **Room Lighting**.
- 4 Press **◀** or **▶** to select **Auto**, **Incandescent**, or **Fluorescent**. Press **EXIT**.

| Mode         | Description   |
|--------------|---|
| Auto         | Smart Sensor detects incandescent and fluorescent room light automatically. |
| Incandescent | Picture color will be warmer.   |
| Fluorescent  | Picture color will be cooler.   |

## ColorMaster™

The ColorMaster™ feature allows you to adjust standard colors.

- 1 **MENU** > **PICTURE** > **Advanced Picture Settings** > **OK**.
- 2 Press **▲** or **▼** to select **ColorMaster**, press **◀** or **▶** to select **On**. Press **EXIT**.

## Base Color Adjustment

When ColorMaster™ is set to **On**, the list of base colors appears. You can select a base color to adjust.

- 1 **MENU** > **PICTURE** > **Advanced Picture Settings** > **OK**.
- 2 Press **▲** or **▼** to select **Base Color Adjustment**. Press **OK**. The **Base Color Adjustment** screen appears.
- 3 Press **▲** or **▼** to select a color. Press **▶**.
- 4 Press **◀** or **▶** to select **Hue**, **Saturation**, or **Brightness**.
- 5 Press **▲** or **▼** to adjust the setting.
- 6 Repeat steps 3 through 5 to adjust other colors. To reset the adjustments to the factory defaults, select **Reset** on the screen. Press **OK**.

## Color temperature

- 1 **MENU** > **PICTURE** > **Advanced Picture Settings** > **OK**.
- 2 Press **▲** or **▼** to select **Color Temperature**. Press **OK**.
- 3 Press **▲** or **▼** to select **Color Temperature**.
- 4 Press **◀** or **▶** to adjust the level. The adjustment range is 0 (warm) to 10 (cool). Press **EXIT**.

**Note:** When the Picture Mode is set to **AutoView**, the adjustment range is -5 to +5.

## Resetting to the factory default

- 1 **MENU** > **PICTURE** > **Advanced Picture Settings** > **OK**.
- 2 Press **▲** or **▼** to select **Reset**. Press **OK**. A confirmation screen appears.
- 3 Select **Yes**. Press **OK**.

## Expert Picture Settings

**Note:** This feature is available when the Picture Mode is set to **Standard**, **Movie 1**, or **Movie 2**. This feature is not available when using Media Player or NET TV feature.

### Test Pattern

When the test pattern is on screen, you can navigate in the Picture submenus without removing the image. When you move to a non-Picture menu, or close the menus, regular video will be restored.

- 1 **MENU** > **PICTURE** > **Expert Picture Settings** > **OK**.
- 2 Select **Test Pattern**.
- 3 Press **◀** or **▶** to select **On**.
- 4 Press **EXIT** to close.

### RGB Filter

This feature individually enables or disables the red, green, and blue components of the picture to allow for more accurate adjustment of each color.

- 1 **MENU** > **PICTURE** > **Expert Picture Settings** > **OK**.
- 2 Press **▲** or **▼** to select **RGB Filter**. Press **OK**.
- 3 Press **▲** or **▼** to select **Red**, **Green** or **Blue** to adjust.
- 4 Press **◀** or **▶** to select **On**.
- 5 Press **▼** to select **Color** or **Tint**, press **◀** or **▶** to adjust. Press **EXIT**.

**Note:** It is not possible to turn off all three colors simultaneously.

### White Balance

#### Window Display

This feature displays the Window Pattern to adjust the white balance with a measuring device.

- 1 **MENU** > **PICTURE** > **Expert Picture Settings** > **OK**.
- 2 Press **▲** or **▼** to select **White Balance**. Press **OK**.
- 3 Press **▲** or **▼** to select **Window Display**.
- 4 Press **◀** or **▶** to select **On**.
- 5 Press **EXIT** to close.

## Setting Type

You can select a way of the white balance's setting.

- 1 **MENU** > **PICTURE** > **Expert Picture Settings** > **OK**.
- 2 Press **▲** or **▼** to select **White Balance**. Press **OK**.
- 3 Press **▲** or **▼** to select **Setting Type**.
- 4 Press **◀** or **▶** to select **2P** or **10P**.

When 2P is selected:

- 1 Press **▼** to select **2P White Balance**.
- 2 Press **▲** or **▼** to select **Red-Offset**, **Green-Offset**, **Blue-Offset**, **Red-Gain**, **Green-Gain**, or **Blue-Gain**. Press **◀** or **▶** to adjust.

When 10P is selected:

- 1 Press **▼** to select **10P White Balance**.
- 2 Press **▲** or **▼** to select **IRE** (White level), **Red**, **Green**, or **Blue**. Press **◀** or **▶** to adjust.

## Copy to All Inputs

This feature copies White Balance on the current input to all other inputs. Individual settings that are not allowed for a specific input will not be copied.

- 1 **MENU** > **PICTURE** > **Expert Picture Settings** > **OK**.
- 2 Press **▲** or **▼** to select **White Balance**. Press **OK**.
- 3 Press **▲** or **▼** to select **Copy to All Inputs**. Press **OK**. A confirmation screen appears.
- 4 Select **Yes**. Press **OK**.

## Resetting to the factory default

- 1 **MENU** > **PICTURE** > **Expert Picture Settings** > **OK**.
- 2 Press **▲** or **▼** to select **Reset**. Press **OK**. A confirmation screen appears.
- 3 Select **Yes**. Press **OK**.

## Viewing the TV's brightness

- 1 **MENU** > **PICTURE** > **Control Visualization** > **OK**. The screen appears.

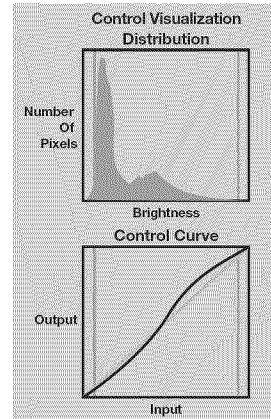

- 2 Press **EXIT** to close.

**Note:** After 10 minutes, the screen closes.

## Locking the picture settings

The TheaterLock™ feature lets you lock items in the **PICTURE** menu that affect the picture's display. These items cannot be modified when the **TheaterLock** is set to **On**.

- 1 **MENU** > **PICTURE** > **TheaterLock**.
- 2 Press **◀** or **▶** to select **On**. Press **EXIT**.

## Adjusting the audio

### Muting the sound

Press **MUTE** to partially reduce (1/2 Mute) or turn off (Mute) the sound. Each time you press **MUTE**, the mute mode changes in this order:



If the closed caption mode is set to **Off** when you select MUTE mode, the closed caption feature becomes active if the TV program is closed-captioned. To mute the audio without activating the closed captioning, press **VOI** to set the volume to 0.

**Note:** If you modify items in the **SOUND** menu while Mute is active, the Mute is cancelled.

### Selecting stereo/SAP broadcasts

The MTS (multi-channel TV sound) feature is only available for analog signals on the **ANT/CABLE** input. When the TV receives a stereo or SAP (second audio program) broadcast, the word STEREO or SAP appears onscreen when **INFO** is pressed.

To listen on stereo sound:

- 1 **MENU** > **SOUND** > **MTS**.
- 2 Press **◀** or **▶** to select **Stereo**. Press **EXIT**.

**Note:**

- You can typically leave the TV in **Stereo** mode because it outputs the type of sound being broadcast (stereo or monaural).
- If the sound is noisy, select **Mono**.

To listen to a second audio program on an analog station (if available):

If provided by individual analog stations, you can transmit a second audio program containing another language, music, or other audio information. For example, you hear the other language instead of the program's normal audio.

- 1 **MENU** > **SOUND** > **MTS**.
- 2 Press **◀** or **▶** to select **SAP**. Press **EXIT**.

**Note:** If there is no sound in **SAP** mode, select **Stereo**.

### Using the MTS button

If you press **MTS** when an analog channel is tuned:

- The Analog Audio bar will appear and will display Stereo, SAP, Mono as the options.

If you press **MTS** when a digital channel is tuned:

- The Digital Audio bar will appear and will offer different audio choices for the digital channel.

If you press **MTS** when an external input is selected:

- No Audio bar is displayed.

### Adjusting the audio balance

You can adjust the audio balance.

- 1 **MENU** > **SOUND** > **Balance**.
- 2 Press **◀** or **▶** to adjust. Press **EXIT**.

### Selecting the optical audio output format

You can select the optical audio output format when you connect a Dolby Digital decoder or other digital audio system to the TV's **DIGITAL AUDIO OUT** terminal.

- 1 Tune to a digital source on the **ANT/CABLE** input.
- 2 **MENU** > **PREFERENCES** > **AV Connection** > **OK**.
- 3 Press **▲** or **▼** to select **Digital Audio Output**.
- 4 Press **◀** or **▶** to select **Auto** or **PCM**. Press **EXIT**.

| Option | Description  |
|--------|--|
| Auto   | Outputs Dolby Digital to the digital audio output if it is being broadcast, otherwise outputs PCM. |
| PCM    | Outputs PCM format to the digital audio output socket.   |

## Using the Dolby® Digital Dynamic Range Control feature

You can further compress Dolby Digital and Dolby Digital Plus dynamic range so you can switch from digital to analog broadcasts at the same dynamic range.

- 1 **MENU** > **SOUND** > **Dynamic Range Control**.
- 2 Press ◀ or ▶ to select **On**.

### Note:

- This feature is available when the Dolby Digital or the Dolby Digital Plus is input to TV in the following situations:
  - When tuned to a digital RF channel.
  - When DLNA Certified products or VUDU is used.
- This feature is not available when **Dolby Volume** is set to **Low** or **High**.
- This feature will also affect the **Digital Audio Output** when the optical audio output format is set to **PCM**.

## Using Dolby® Volume

This feature provides a consistent sound volume regardless of programs, channels or input sources.

- 1 **MENU** > **SOUND** > **Dolby Volume**.
- 2 Press ◀ or ▶ to select **Low**, **High** or **Off**.

### Note:

- If **Dynamic Range Control** is set to **On**, this feature will be not available.
- This feature does not affect the audio signal output from the **DIGITAL AUDIO OUT**.

## Using advanced sound features

### Using surround sound

Smart Sound Equalizer, Surround, Voice Enhancement, and Dynamic Bass Boost help to create a thrilling surround sound experience with deep, rich bass from stereo sound sources. Your TV's audio will sound fuller, richer, and wider.

**Note:** Surround features are only available for **Stereo** mode (☞ "Selecting stereo/SAP broadcasts" on p. 53).

- 1 **MENU** > **SOUND** > **Advanced Sound Settings** > **OK**.
- 2 Press ▼ or ▲ to highlight the feature to adjust. Press ◀ or ▶ to adjust the item.

| Mode                  | Description  |
|-----------------------|--|
| Smart Sound Equalizer | Selects a TV Mounting mode ( <b>Stand</b> or <b>Wall</b> ), and adjusts equalizer (☞ p. 28).   |
| Surround              | Selects a mode ( <b>Spatial</b> , <b>Cinema</b> , or <b>Off</b> ).<br><b>Spatial:</b> reproduces an expansive and deep sound<br><b>Cinema:</b> delivers realistic sound similar to what you would experience in a movie theater. |
| Voice Enhancement     | Turns the vocal emphasis effect <b>On</b> or <b>Off</b> .  |
| Dynamic Bass Boost    | Selects a bass expansion level ( <b>Off</b> , <b>Low</b> , or <b>High</b> ).   |

# Chapter 8: Advanced features

## Using your home network

- This TV is a DLNA CERTIFIED™ Player and Renderer. This TV can play digital content stored on a DLNA CERTIFIED™ product with server function. If you want to use this TV as a DLNA CERTIFIED™ Player or Renderer, you will have to configure the network settings on your TV (☞ p. 22).
- If you want to use your home network with an Internet connection, you will have to configure the network settings on your TV (☞ p. 22). Change the network settings if necessary (☞ “Setting up the Network” on p. 56).

### If you use Internet services, see the following note before using it.

Third party internet services are not provided by Toshiba, may change or be discontinued at any time and may be subject to third party restrictions. Toshiba makes no warranties, representations, or assurances about the content, availability or functionality of third party content or services. Third party internet services may require the creation of a separate account through a computer with internet access, and payment of one-time and/or recurring charges.

### When you enjoy Internet services by wireless:

#### **Wireless LAN and your Health:**

*Wireless LAN products, like other radio devices, emit radio frequency electromagnetic energy. The level of energy emitted by Wireless LAN devices however is far much less than the electromagnetic energy emitted by wireless devices like for example mobile phones.*

*Because Wireless LAN products operate within the guidelines found in radio frequency safety standards and recommendations, TOSHIBA believes Wireless LAN is safe for use by consumers. These standards and recommendations reflect the consensus of the scientific community and result from deliberations of panels and committees of scientists who continually review and interpret the extensive research literature.*

*In some situations or environments, the use of Wireless LAN may be restricted by the proprietor of the building or responsible representatives of the organization. Such restriction may apply in environment where the risk of interference to other devices or services is perceived or identified as harmful.*

*If you are uncertain of the policy that applies on the use of wireless devices in a specific organization or environment, you are encouraged to ask for authorization to use the Wireless LAN device prior to turning on the equipment.*

#### **Using under wireless LAN environment:**

- It is recommended to use IEEE 802.11a or IEEE 802.11n on 5 GHz for audio and SD video streaming.
- It is recommended to use IEEE 802.11n on 5 GHz for HD video streaming.
- It is recommended that the encoding rate of video content be 20 Mbps or less.
- It is not recommended to use 2.4 GHz for audio and video streaming.
- Content playback may be interrupted by surrounding various interference.

## Setting up the Network

You can select the Network Type.

- 1 **MENU** > **PREFERENCES** > **Network Setup** > **OK**.
- 2 Press **▲** or **▼** to highlight **Network Type**.
- 3 Press **◀** or **▶** to select **Wired** or **Wireless**.
- 4 If you select **Wired**, see “Advanced Network Setup” (p. 58).  
If you select **Wireless**, see the next section.

## Wireless Setup

### Note:

- Continued connection to AP (Access Point) is not guaranteed. The connection may be lost while watching TV.

There are 3 methods for wireless setup:

#### • Easy Setup (WPS)

If AP supports WPS, this can be used.

- WPS is a standard designed to execute connection of wireless LAN equipment and setup of security easily. WPS will automatically configure all wireless settings.

#### • Assisted Setup (setup by using AP's notification information)

Network Name, Authentication, and Encryption are decided based on information from AP. You manually set the Security Key.

#### • Manual Setup (to input all settings)

## Easy Setup using PBC (Push Button Configuration)

- 1 **MENU** > **PREFERENCES** > **Network Setup** > **OK**.
- 2 Press **▲** or **▼** to select **Wireless Setup**. Press **OK**.
- 3 Press **▲** or **▼** to select **Easy Setup**. Press **OK**.
- 4 Press **◀** or **▶** to select **PBC**.
- 5 Press **▼** to select **Start Scan**. Press **OK**.
- 6 Following the onscreen instruction, push the appropriate button on your AP.
- 7 When a screen reporting that the setup succeeded appears, press **OK**.

### To cancel searching for the AP:

Press **RETURN** while searching for the AP. A message will appear. Press **◀** or **▶** to select **Yes**. Press **OK**.

## Easy Setup using PIN (Personal Identification Number)

- 1 **MENU** > **PREFERENCES** > **Network Setup** > **OK**.
- 2 Press **▲** or **▼** to select **Wireless Setup**. Press **OK**.
- 3 Press **▲** or **▼** to select **Easy Setup**. Press **OK**.
- 4 Press **◀** or **▶** to select **PIN**.
- 5 Press **▼** to select **Start Scan**. Press **OK**.
- 6 Scan screen appears. Enter the PIN displayed on this screen into your PC or AP.
- 7 Press **▲** or **▼** to select the desired AP. Press **OK**.  
**Note:** Check the MAC address on the label or in the manual of the AP and select an AP.
- 8 When a screen reporting that the setup succeeded appears, press **OK**.

### To cancel searching for the AP:

Press **RETURN** while searching for the AP. A message will appear. Press **◀** or **▶** to select **Yes**. Press **OK**.

## Assisted Setup

- 1 **MENU** > **PREFERENCES** > **Network Setup** > **OK**.
- 2 Press **▲** or **▼** to select **Wireless Setup**. Press **OK**.
- 3 Press **▲** or **▼** to select **Assisted Setup**. Press **OK**.
- 4 Press **▲** or **▼** to select the desired AP. Press **OK**.  
**Note:** Check the MAC address on the label or in the manual of the AP and select an AP.
- 5 Select **Security Key**. Press **OK**. The Software Keyboard appears.
- 6 Input the Security Key by using the Software Keyboard (p. 60). To save your setting, press the **BLUE** button.  
**Note:** The Security Key must adhere to these conditions:  
-TKIP/AES: 8-63 ASCII or 64 Hex characters  
-WEP: 5 or 13 ASCII or 10 or 26 Hex characters
- 7 Press **▲** or **▼** to highlight Key ID. Press **◀** or **▶** to select 1, 2, 3 or 4.  
**Note:** When **Encryption** is set to **WEP**, this option is available.
- 8 Select **Done**. Press **OK**.  
**Note:** If **Network Name** is not displayed, see step 4 and 5 in **Manual Setup** (in the next section) to set **Network Name** before pressing **Done**.

**Note:** Settings are not saved if **RETURN** is pressed before **Done** is selected.



## Manual Setup

- 1 **MENU** > **PREFERENCES** > **Network Setup** > **OK**.
- 2 Press **▲** or **▼** to select **Wireless Setup**. Press **OK**.
- 3 Press **▲** or **▼** to select **Manual Setup**. Press **OK**.
- 4 Press **▲** or **▼** to select **Network Name**. Press **OK**. The Software Keyboard window appears.
- 5 Input the Network Name by using the Software Keyboard (p. 60). To save your setting, press the **BLUE** button.
- 6 Press **▲** or **▼** to highlight **Authentication**. Press **◀** or **▶** to select **Open System, Shared Key, WPA-PSK** or **WPA2-PSK**.
- 7 Press **▲** or **▼** to highlight **Encryption**. Press **◀** or **▶** to select **None, WEP, TKIP** or **AES**.

**Note:**

- Certain encryption types are only compatible with specific authentication types.
  - When Authentication is Open System, only WEP or None are compatible.
  - When Authentication is Shared Key, only WEP is compatible.
  - When Authentication is WPA-PSK or WPA2-PSK, only TKIP or AES are compatible.
- When incompatible Authentication/Encryption pairings are attempted, a warning message will be displayed, and no connection attempt will be made until the incompatibility is resolved.

- 8 Press **▲** or **▼** to select **Security Key**. Press **OK**. The Software Keyboard window appears.
- 9 Input the Security Key by using the Software Keyboard (p. 60). To save your setting, press the **BLUE** button.

**Note:** This item is grayed out when **Encryption** is **None**.

- 10 Press **▲** or **▼** to highlight Key ID. Press **◀** or **▶** to select 1, 2, 3 or 4.

**Note:** When **Encryption** is set to **WEP**, this option is available.

- 11 Select **Done**. Press **OK**.

**Note:** When **Encryption** is **None**, a message will appear. Press **◀** or **▶** to select **Yes** and press **OK**.

**Note:** Settings are not saved if **RETURN** is pressed before **Done** is selected.

## Enhanced 11n

When Enhanced 11n is set to On, these features are available.

- Dual Channel (40MHz)
- GF (Green Field)

**Note:** In addition, some 11n's option feature become effective.

- 1 **MENU** > **PREFERENCES** > **Network Setup** > **OK**.
- 2 Press **▲** or **▼** to select **Wireless Setup**. Press **OK**.
- 3 Press **▲** or **▼** to highlight **Enhanced 11n**. Press **◀** or **▶** to select **On**.

## Wireless Information

The settings configured in **Wireless Setup** can be confirmed.

**Note:** When **Network Type** is **Wireless**, this menu is available from the Quick menu.

- 1 Press **Quick** to open the Quick menu.
- 2 Press **▲** or **▼** to select **Wireless Information**. Press **OK**.
- 3 When the AP connection succeeds, a Wireless Information screen will appear.

**Note:** Press the **RED** button to check the availability of surrounding APs.

| Item            | Description  |
|-----------------|--|
| Status          | <b>Connected</b> is displayed when the TV is connected to the AP.<br><b>Disconnected</b> is displayed when the TV is disconnected to the AP. |
| Signal          | Connection signal strength with AP ( <b>STRONG/MEDIUM/WEAK</b> )   |
| Speed           | The link speed with AP   |
| Mode            | Working mode (11a, 11b, 11g, 11n)  |
| Channel         | A channel in use (1-165)   |
| Network Name    | SSID set   |
| Authentication  | Authentication set   |
| Encryption      | Encryption set   |
| Security Key    | Security Key set   |
| AP MAC Address  | The AP's MAC address is displayed when the TV is connected to AP.  |
| TV MAC Address  | The TV's MAC address   |
| DHCP            | <b>Enabled</b> is displayed when you use DHCP.<br><b>Disabled</b> is displayed when you do not use DHCP.                                     |
| IP Address      | The TV's IP address  |
| Subnet Mask     | Value of the Subnet Mask   |
| Default Gateway | Default GATEWAY's address  |
| DNS             | DNS's address  |

**Note:** Even if AP for IEEE 802.11n is used when **Encryption** is set to **WEP** or **TKIP**, the **Speed** value might be low. We recommend that the **Encryption** setting to be changed to **AES** (Under manual setup).

## Advanced Network Setup

### Note:

- When the DHCP function of the router connected with this TV is On, you can set **Auto Setup** to On or Off. (Usually set it to **On**.)
- When the DHCP function of the router is Off, set **Auto Setup** to **Off**, and manually set IP Address or DNS Address.

## IP Address Setup

### Auto Setup:

- 1 **MENU** > **PREFERENCES** > **Network Setup** > **OK**.
- 2 Press **▲** or **▼** to select **Advanced Network Setup**. Press **OK**.
- 3 Press **▲** or **▼** to select **IP Address Setup**. Press **OK**.
- 4 Select **Auto Setup**. Press **◀** or **▶** to select **On**.

**Note:** Other items will be grayed out when **Auto Setup** is set to **On**.

### Manual Setup:

- 1 **MENU** > **PREFERENCES** > **Network Setup** > **OK**.
- 2 Press **▲** or **▼** to select **Advanced Network Setup**. Press **OK**.
- 3 Press **▲** or **▼** to select **IP Address Setup**. Press **OK**.
- 4 Select **Auto Setup**. Press **◀** or **▶** to select **Off**.
- 5 Press **▲** or **▼** to highlight **IP Address**.
- 6 Press **◀** or **▶** to highlight the field you want to change, and then use the number buttons to input the IP address. To save the setting, press **OK**.

### Note:

- IP address field numbers must be between 0 and 255. If you input an incompatible number and press **OK**, the field number will reset to the previous value.
- 7 Press **▲** or **▼** to highlight **Subnet Mask**, and edit in the same way as IP Address.
  - 8 Press **▲** or **▼** to highlight **Default Gateway**, and edit in the same way as IP Address.

**Note:** If you manually set the IP address, you must not use the same IP address for any other device. The IP address you use should be a private address. If you do not know the correct values to use, please contact your network administrator or internet service provider.

## DNS Setup

**Note:** When the DHCP function of the router connected to this TV is Off, set **Auto Setup** to **Off**, and manually set the DNS address(es). Your internet service provider should have provided these to you.

Auto setup:

- 1 **MENU** > **PREFERENCES** > **Network Setup** > **OK**.
- 2 Press **▲** or **▼** to select **Advanced Network Setup**. Press **OK**.
- 3 Press **▲** or **▼** to select **DNS Setup**. Press **OK**.
- 4 Select **Auto Setup**. Press **◀** or **▶** to select **On**.

**Note:** Other items will be grayed out when **Auto Setup** is set to **On**.

Manual setup:

- 1 **MENU** > **PREFERENCES** > **Network Setup** > **OK**.
- 2 Press **▲** or **▼** to select **Advanced Network Setup**. Press **OK**.
- 3 Press **▲** or **▼** to select **DNS Setup**. Press **OK**.
- 4 Select **Auto Setup**. Press **◀** or **▶** to select **Off**.
- 5 Press **▲** or **▼** to highlight **Primary DNS Address**.
- 6 Press **◀** or **▶** to highlight the field you want to change, and then use the number buttons to input the Primary DNS Address. To save the setting, press **OK**.

**Note:**

- DNS address field numbers must be between 0 and 255. If you input an incompatible number and press **OK**, the field number will reset to the previous value.

- 7 Press **▲** or **▼** to highlight **Secondary DNS Address**, and edit in the same way as Primary DNS Address.

**MAC Address**

You can view the fixed MAC address for the TV, if one is installed.

- 1 **MENU** > **PREFERENCES** > **Network Setup** > **OK**.
- 2 Press **▲** or **▼** to select **Advanced Network Setup**. Press **OK**.
- 3 Press **▲** or **▼** to select **MAC Address**. Press **OK**.

**Network Connection Test**

This function checks Internet connectivity.

- 1 **MENU** > **PREFERENCES** > **Network Setup** > **OK**.
- 2 Press **▲** or **▼** to select **Network Connection Test**. Press **OK**.

**Note:** A message will appear to indicate if the connection was successful or if it could not be completed.

**Note:** The result of Network Connection Test does not always guarantee the connection. Depending on the situation, some Internet features may not be available.

**To cancel the Network Connection Test:**

Press **EXIT** while searching for the Internet connection.

## Using the software keyboard

You can enter text by using the Software Keyboard. The Software Keyboard window will appear when you press **OK** on a field that accepts character input.

**Note:** In the NET TV feature, software keyboard depends on each internet service.

To enter text using the software keyboard:

- 1 Highlight the desired character in the onscreen software keyboard.
- 2 Press **OK**.
- 3 Repeat steps 1 and 2 until you have entered all desired text.
- 4 Press the **BLUE** button to close the software keyboard and return to the previous screen.

**Note:** If **RETURN** is pressed, changes are not saved and the software keyboard window is closed.

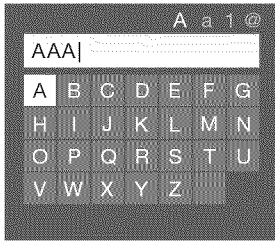

Input operation on the remote control:

| Button                  | Description  |
|-------------------------|--|
| <b>OK</b>               | Inputs the selected character.   |
| 0-9                     | Inputs the number directly.  |
| ▲ ▼ ◀ ▶                 | Moves the character highlight.   |
| <b>REW</b> ◀▶ <b>FF</b> | Moves the cursor.  |
| <b>SKIP</b> ◀▶          | Moves the cursor to the head of a character string.                        |
| <b>SKIP</b> ▶▶          | Moves the cursor to the end of a character string.                         |
| <b>RED</b>              | Deletes 1 character to the left of the cursor.                             |
| <b>GREEN</b>            | Cycles through upper case, lower case, numbers, and symbols, if available. |
| <b>YELLOW</b>           | Chooses an accented version of the current letter, if applicable.          |
| <b>BLUE</b>             | Saves changes and closes the Software Keyboard window.                     |
| <b>RETURN</b>           | Closes the Software Keyboard window without saving changes.                |

## Performing a Software Upgrade

TOSHIBA may offer upgrades for the TV's software in the future. The TV's software is upgraded via the Network.

**Before downloading software:**

Configure your TV to connect to the Internet.

**Note:**

- You will not be able to use the TV set while the upgrade is being performed.
- Do not turn off the TV during upgrading.

1 **MENU** > **SETUP** > **Software Upgrade** > **OK**.

2 **Network Upgrade** is displayed. Press **OK**.

**Note:** If the network is not available, a warning message will appear.

3 The TV software upgrade will start when download succeeds.

## Viewing the Software Licences

The Licenses for the software used in this TV are available for viewing.

1 **MENU** > **SETUP** > **Software Licences** > **OK**.

A screen will appear displaying all the licensing information required for the television's software.

## Using the NET TV™ feature

**Note:**

- You need to connect to the Internet before using this feature (see p. 22).
- Services that can be used vary from country to country.
- When VGA, SVGA, XGA, WXGA, or SXGA is used, this feature is not available.
- On rare occasions, ColorStream 480i or 1080i signals from some video devices may not be correctly displayed on the TV.
- After turning on the TV this feature may not be available for a few minutes while the system is booting up.

## NET TV menu

- 1 Press **NET TV**.  
(From the Menu: **MENU** > **APPLICATIONS** > **NET TV** > **OK**.)
- 2 Press **◀** or **▶** to select an icon. Press **OK**.

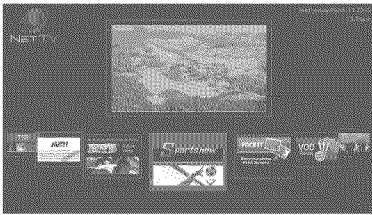

**Note:**

- When you access the NET TV menu for the first time, a welcome screen appears (see "Guided Setup" below). After setup is complete, this feature is available.
- If the Picture Mode is set to **Game** or **PC**, this feature is not available.
- The closed caption feature is not displayed while this feature is being used.
- If the display of the date and time is wrong, turn off the TV, and turn it on again.
- NET TV menu items may change in the upgrade process.

## Guided Setup

The first time you use Yahoo! TV Widgets this step-by-step wizard begins with the Welcome Screen.

- 1 Select **Let's get started!**  
If you select **Exit Setup** now, this step will resume the next time you press **OK**.

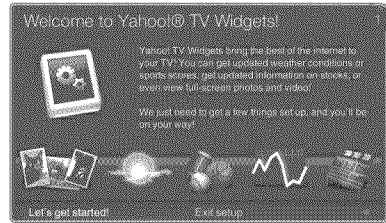

- 2 Follow the onscreen instructions.

**After completing the Guided Setup:**

- When you press **NET TV** or select **NET TV** from the Menu, the NET TV menu is displayed.
- When you press **OK** or select **Widgets** from the Menu, the TV Widgets user interface is displayed.

## Netflix

### Watching movies with Netflix

- 1 Press **NET TV**.  
(From the Menu: **MENU** > **APPLICATIONS** > **NET TV** > **OK**.)
- 2 Press **◀** or **▶** to select Netflix icon. Press **OK**.
- 3 If you are not a Netflix member:  
Select **no - start my FREE trial**.  
Visit <http://www.netflix.com/toshiba> from your PC. Sign up to create your account, then select **I'm now a member**.

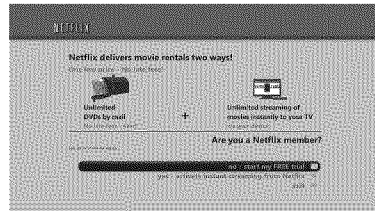

If you are a Netflix member:

Select **Yes - activate instant streaming from Netflix**.

- 4 Read the instructions displayed on the TV screen, and visit <http://www.netflix.com/activate> on your PC.  
Sign in to your Netflix account, if necessary.

Enter the activation code displayed on the TV screen.

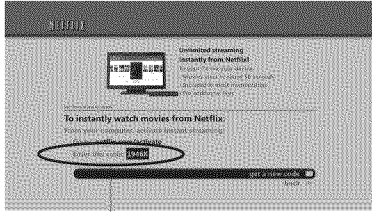

Activation code

- To add movies and TV episodes to your Instant Queue, visit <http://www.netflix.com> on your PC. Sign in to your account, and then select **Watch Instantly**.

After having activated Netflix player and prepared Instant Queue, movies and TV episodes in your Instant Queue appear on the TV screen. Select your desired one using the remote control.

**Note:**

- Resolution of video streamed from Netflix varies depending on communication speed or bit-rate of each content, etc.
- Screens and messages may change in the upgrade process.

**Control Netflix streaming video on the remote control:**

| Button      | Description  |
|-------------|--|
| PLAY        | To start playing movie.<br>To pause playback while in PLAY mode.   |
| STOP        | To stop playing and return to a list of movie titles.  |
| PAUSE/STEP  | To pause playing movie.  |
|             | To pause playing and open a list of scenes. Pressing further proceeds to the previous/next scene.                            |
|             | To stop playing and return to a list of movie titles.  |
| FF          | To pause play and open a list of scenes. Fast forward play starts.   |
| REW         | To pause play and open a list of scenes. Fast reverse play starts.   |
| HOME (BLUE) | To stop playing and return to Home menu.   |
|             | To pause playing of Trick play screen while in PLAY mode.<br>To start playing the movie if you are in the Trick play screen. |

**To confirm the Netflix ESN (Electronic Serial Number):**

- > **PREFERENCES** > **Netflix Setup** > .
- Press or to select **ESN**. Press . Netflix ESN is displayed.

**To deactivate your device:**

- > **PREFERENCES** > **Netflix Setup** > .
- Press or to select **Deactivation**. Press .
- Press or to select **Yes**. Press .

**VUDU™**

VUDU™ is an on-demand service that offers high-definition movies on the Web.

- Press .  
(From the Menu: > **APPLICATIONS** > **NET TV** > .)
- Press or to select **VUDU**. Press .

**Note:** Use of VUDU requires a working broadband internet connection (1 to 2 Mbps for SD video, 2.25 to 4.5 Mbps for HD video and 4.5 to 9 Mbps for HDX video).

**To deactivate your device:**

- > **PREFERENCES** > **VUDU Deactivation** > .
- Press or to select **Yes**. Press .

**YouTube™**

YouTube is a video-sharing service managed by YouTube, LLC. This TV allows you to view YouTube content.

- Press .  
(From the Menu: > **APPLICATIONS** > **NET TV** > .)
- Press or to select **YouTube**. Press .
- Press , , or to select the file you want to view. Press .

**To close YouTube:**

Press **EXIT**.

**Note:**

- YouTube contents have been independently managed by YouTube, LLC.
- Not all YouTube contents that can be accessed by computer may be viewed with this TV.
- This TV may not be able to do some operations that computer can do.
- Depending on network environment and the use situation, content may be difficult to view.

- Though the same volume value, an actual volume might be greatly different depending on contents.
- This TV might take time during start-up and the playback of contents.
- Content that the user may feel is improper or offensive may be included in the contents of YouTube.
- We do not assume any responsibility for contents that YouTube offers.
- If you have any questions about YouTube contents, please contact YouTube, LLC.
- The content of service and the screen that can be used may be changed without a previous notice.
- You cannot post videos to YouTube from this TV. Please use a PC to post videos.
- Not all contents can be viewed normally when you access websites other than YouTube XL through this TV.

### To use Function menu:

- 1 Press the **BLUE** button while displaying YouTube. The Function menu screen appears.
- 2 Press ◀ or ▶ to select the desired icon. Press **OK**.

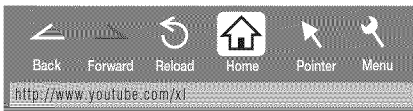

| Item             | Description   |
|------------------|---|
| Back             | Returns to the previous page.   |
| Forward          | Moves to the forward page.  |
| Reload/<br>Abort | Updates the displayed page./<br>Aborts update<br>( X is displayed while reading, and ↺ is displayed in other case.) |
| Home             | Returns to the top page of YouTube.   |
| Pointer          | Switches the pointer On/Off or drag mode.   |
| Menu             | Switches the frame or sets various settings (refer p. 63-64).   |

### Switching the pointer

The tool that operates the screen can be changed to the pointer or the drag mode.

**Note:** When **Pointer: OFF** is selected and ▲, ▼, ◀ or ▶ is pressed, the highlight moves to linked areas.

#### To use the Pointer: ON:

- 1 From the Function menu, press ◀ or ▶ to select **Pointer**. Press **OK**.
- 2 Press ▲ or ▼ to select **Pointer: ON**. Press **OK**.
  - appears.
- 3 Press ▲, ▼, ◀ or ▶ to the place where changes to . Press **OK**.

#### To use the Drag Mode:

- 1 From the Function menu, press ◀ or ▶ to select **Pointer**. Press **OK**.
- 2 Press ▲ or ▼ to select **Pointer: ON**. Press **OK**.
- 3 Press the **BLUE** button.
- 4 Press ◀ or ▶ to select **Pointer**. Press **OK**.
- 5 Press ▲ or ▼ to select **Drag Mode**. Press **OK**.
  - appears.
- 6 Press **OK**.
  - changes to .
- 7 Press ▲, ▼, ◀ or ▶ to move the selected item in the desired place.

### Switching the frame

- 1 From the Function menu, press ◀ or ▶ to select **Menu**. Press **OK**.
- 2 Press ◀ or ▶ to select **Page Tasks**.
- 3 Select **Switch Frames**. Press **OK**.

### Setting the view feature

- 1 From the Function menu, press ◀ or ▶ to select **Menu**. Press **OK**.
- 2 Press ◀ or ▶ to select **View**.
- 3 Press ▲ or ▼ to select the desired item. Press **OK**.
- 4 Press ▲ or ▼ to select the desired setting. Press **OK**.

| Item                | Settings   |
|---------------------|--|
| Display Mode        | <b>Normal:</b> Displays YouTube page with the size as it is.<br><b>Just-Fit Rendering:</b> Displays YouTube page by a size that the width was adjusted to be suitable for this TV. |
| Text Size           | Changes the font size of the screen. Select from <b>Largest, Large, Medium, Small</b> or <b>Smallest</b> .<br><b>Note:</b> This font size is effective only for the page.          |
| Advanced Settings   | See the next column.   |
| Page Information    | Displays the information of the page you are viewing.  |
| Server Certificates | Displays the server certification.   |

#### If you select Advanced Settings:

- 1 Press ▲, ▼, ◀ or ▶ to select items. Press **OK**. The box is selected. To clear the selection, press **OK**.
- 2 Press ▲, ▼, ◀ or ▶ to select OK field. Press **OK**.

| Item                 | Description  |
|----------------------|--|
| Image                | Sets display / non-display of images.  |
| Table                | Sets effect / non-effect of tables.  |
| CSS                  | Sets effect / non-effect of CSS.   |
| Japanese hyphenation | Sets effect / non-effect of the Japanese hyphenation.  |
| Pop-up window        | Sets effect / non-effect of pop-up windows.  |
| Animation            | Sets display / non-display of animations.  |
| JavaScript           | Sets effect / non-effect of JavaScript.  |
| Word wrap            | Sets effect / non-effect of Word Wrap. If Word Wrap is enabled, a word not finished at the end of line is shifted to the next line.  |
| Rapid-Render         | Sets effect / non-effect of Rapid-Render. If Rapid-Render is enabled, text and links are displayed first, then images and tables, etc. are displayed. The highlight can be moved with the text and the link displayed. |

### Setting other features

- 1 From the Function menu, press ◀ or ▶ to select **Menu**. Press **OK**.
- 2 Press ◀ or ▶ to select **Settings**.
- 3 Press ▲ or ▼ to select the desired item. Press **OK**.
- 4 Press ▲ or ▼ to select the desired setting. Press **OK**.

| Item                | Settings   |
|---------------------|--|
| Security            | When jumping from a protected page to an unprotected page, the message is displayed when the check is applied to <b>Notify of secure/non-secure page changes</b> .<br>Apply the check to select SSL version from <b>SSL Version to use (SSL2.0, SSL3.0, TSL1.0)</b> .<br>A content confirmation of the certification and a setting effect / non-effect can be done in <b>Root Certificates</b> and <b>CA Certificates</b> (see next column). |
| Cookies             | <b>Accept all:</b> Cookie is received, and it records in this TV.<br><b>Reject all:</b> Cookie is not received.<br><b>Prompt before accepting:</b> When Cookie is received, a message window will be displayed.  |
| Delete Cookies      | Deletes all recorded Cookies.  |
| Cache               | <b>Use cache:</b> When the check is applied to this, cache is used.<br><b>Delete All Cache Data:</b> Deletes all the cache preserved in the television.  |
| Browser Information | Displays the information on a browser.   |

#### Note:

- Cookies are technical information left in TV memory by visited web sites that identify you to the web sites on future visits.
- Cache is a memory system used to shorten the display time of revisited web pages by checking the past data (cookies) stored in the TV on the first visit to a web page.

#### To confirm Root Certificates or CA Certificates:

- 1 Select **Security** in step 3 above.
- 2 Press ▲, ▼, ◀ or ▶ to select **Root Certificates** or **CA Certificates**. Press **OK**.
- 3 Press ▲ or ▼ to select the desired certificate:
  - When **OK** is pressed, a detailed information screen appears.
  - When the **BLUE** button is pressed, **Disable** or **Enable** bar appears. It changes whenever **BLUE** button is pressed.
- 4 Press **RETURN**.



## Yahoo! TV Widgets

Yahoo! TV Widgets provide an integrated Internet and TV experience powered by the Yahoo! Connected TV platform. Yahoo! TV Widgets allow you to:

- Track your stocks and stay current with financial news.
- Share photos with friends and family.
- Watch your favorite web videos.

- 1 Press . (From the Menu: **MENU** > **APPLICATIONS** > **Widgets** > **OK**.)

The **Dock** is the horizontal list of snippets appearing at the bottom of your TV screen.

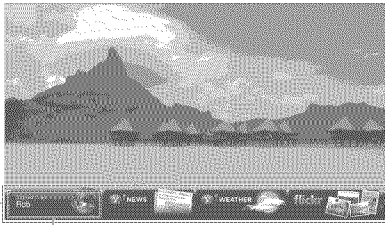

A **snippet** is a shortcut which launches a TV Widget.

- 2 Focus is located in the leftmost region (the highlighted snippet). The dock scrolls snippets under this focal point. Press **◀** or **▶** to focus on a snippet. Press **OK** to select a snippet.
- 3 The TV Widget sidebar appears. Press **▲** or **▼** to select a menu item. Press **OK**.

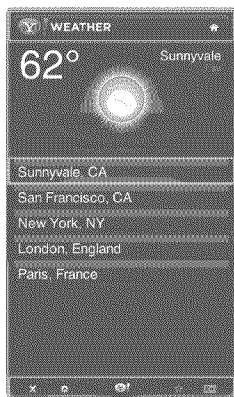

The TV Widget logo and Home button

The currently focused button is highlighted.

The sidebar's bottom toolbar includes four color-coded buttons that map to the colored keys on the remote control.

| Button | Description  |
|--------|--|
| RED    | Closes the widget.   |
| GREEN  | Changes the widget's settings.                               |
| YELLOW | Adds or deletes a snippet.                                   |
| BLUE   | Resizes the video to fit onscreen, or to make it fullscreen. |

**To close Yahoo! TV Widgets:**

Press **EXIT**.

### Note:

- To use Yahoo! TV Widgets you must first complete the "Guided Setup" (see p. 61).
- If the Picture Mode is set to **Game** or **PC**, this feature is not available.
- The closed caption feature is not displayed while this feature is being used.

## Using the Profile Widget

- The **Profile Widget** configures your user profile.
- You can set up multiple profiles for multiple users.
- Each profile maintains its own list of TV Widgets.
- The **Switch Profile** menu allows you to switch to a different user profile.
- The **Profile Settings** menu allows you to customize and protect your profile.
- The **System Settings** menu allows you to change your **Location**, **Repeat the Tutorial**, and **Restore Factory Settings**, which deletes all profiles and TV Widget settings (not TV settings). The **Location** and **Restore Factory Settings** menus turn off the TV to apply the changes, and then turn on the TV again.
- The **Administrative Controls** menu allows you to set the **Screen Saver** timeout, create the **Owner PIN**, and to **Create a Profile**.
- The **Sign in to Yahoo!** menu allows you to personalize your experience using your Yahoo! ID.
- Visit <http://www.yahoo.com> to create a Yahoo! ID.

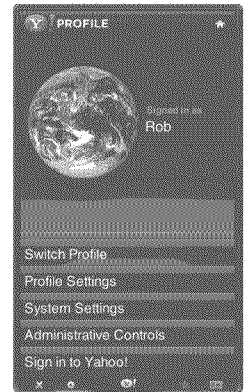

## Using the Widget Gallery

- The **Widget Gallery** allows you to browse and discover new TV Widgets.
- The featured TV Widgets are highlighted in the display case at the top of the sidebar.
- You can also browse available TV Widgets by category.
- To install a widget, select **Add Widget to My Profile** and press **OK**.
- The **Owner PIN** is needed to install widgets for profiles that have been protected through the **Limit Profile** indicator under the **Profile Widget** → **Profile Settings** menu.
- Refer to the **Profile Widget** → **Administrative Controls** menu to set the **Owner PIN**.

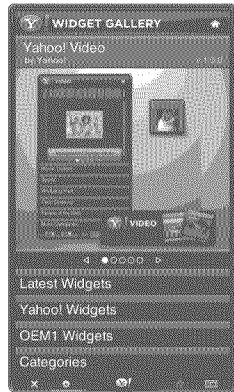

## Using other Yahoo! Widgets

- The **Yahoo! News Widget** provides the latest headline news for business, entertainment, politics, sports, top stories, and many other categories.
- The **Yahoo! Weather Widget** provides updates on your local and favorite weather locations.
- View the latest stock news with the **Yahoo! Finance Widget**.
- The **flickr Widget** enables slideshows of family and friends' photos on your TV.

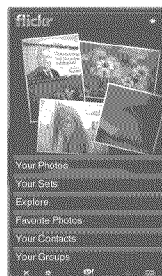

## Setting up the Media Renderer feature

Term meaning:

- DMS: DLNA CERTIFIED™ Server
- DMR: DLNA CERTIFIED™ Renderer
- DMC: DLNA CERTIFIED™ Controller

The TV can be configured as a DMR. When operating as a DMR, the TV displays contents provided by a DMS. The selection of the media is done by the DMC. The TV can play photo, movie, or audio files when operating as a DMR.

### Installation

You can configure the DMR settings individually, or use Installation mode to be prompted for each setting in order.

- 1 **MENU** > **PREFERENCES** > **Media Renderer Setup** > **OK**.
- 2 Press **▲** or **▼** to select **Installation**. Press **OK**.
- 3 Press **◀** or **▶** to select **On**. Press **OK**.
- 4 If you want to change the device name as a Renderer, highlight the Device Name field and press **OK**. The Software Keyboard screen appears.
- 5 Input the Device Name by using the Software Keyboard (p. 60). To save your setting, press the **BLUE** button.
 

*Note: The Device Name can be up to 127 characters long.*
- 6 Select **Done**. Press **OK**.
- 7 If you want to change the password, press **◀** or **▶** to select **Yes**. Press **OK**.
- 8 Change the password by using the Software Keyboard (p. 60). Press the **BLUE** button.
 

*Note: The Web Password can be up to 15 characters long.*
- 9 Select **Done**. Press **OK**.
- 10 If you want to limit access from unexpected DMCs, press **◀** or **▶** to select **On**. Press **OK**.
- 11 If you want to proceed with registration of DMCs, press **◀** or **▶** to select **Yes**. Press **OK**.
- 12 Press **▲** or **▼** to select the item you want to accept. Press **OK**. The box is selected. To clear the selection, press **OK**.
- 13 Press **▶** to select **Done**. Press **OK**.
- 14 Press **◀** or **▶** to adjust to the desired volume. Press **OK**.

## Media Renderer

- 1 **MENU** > **PREFERENCES** > **Media Renderer Setup** > **OK**.
- 2 Press **▲** or **▼** to highlight **Media Renderer**. Press **◀** or **▶** to select **On** or **Off**.

## Device Name Setup

The device name as a DMR can be changed. The set device name can be confirmed from the DMC.

- 1 **MENU** > **PREFERENCES** > **Media Renderer Setup** > **OK**.
- 2 Press **▲** or **▼** to select **Device Name Setup**. Press **OK**.
- 3 Select the Device Name field. Press **OK**. The Software Keyboard screen appears.
- 4 Input the Device Name by using the Software Keyboard (☞ p. 60). To save your setting, press the **BLUE** button.
 

**Note:** The Device Name can be up to 127 characters long.
- 5 Select **Done**. Press **OK**.

## Web Password Setup

This setup sets a necessary password for the DMC's accessing a built-in Web page of a DMR.

- 1 **MENU** > **PREFERENCES** > **Media Renderer Setup** > **OK**.
- 2 Press **▲** or **▼** to select **Web Password Setup**. Press **OK**.
- 3 Select the Password field. Press **OK**. The Software Keyboard screen appears.
- 4 Change the password by using the Software Keyboard (☞ p. 60). Press the **BLUE** button.
 

**Note:**

  - The Web Password can be up to 15 characters long.
  - Only the password can be changed. User ID cannot be changed.
- 5 Select **Done**. Press **OK**.

**Note:**

- Some DMC can view or modify the device name of the DMR.
- Depending on the TV's state, the device name may not be set from Web page.
- Confirm the DMCs instruction manual for the way of accessing Web pages.

## Media Controller Setup

You can limit which DMC can control this TV.

If Access Control is enabled, only those DMCs with a check will be allowed to control the TV.

- 1 **MENU** > **PREFERENCES** > **Media Renderer Setup** > **OK**.
- 2 Press **▲** or **▼** to select **Media Controller Setup**. Press **OK**.
- 3 Press **▲** or **▼** to highlight **Access Control**. Press **◀** or **▶** to select **On**.
- 4 Press **▲** or **▼** to select **Select Media Controller**. Press **OK**.
- 5 Press **▲** or **▼** to select the item you want to accept. Press **OK**.  
The box is selected. To clear the selection, press **OK**.
- 6 Press **▶** to select **Done**. Press **OK**.

**Note:**

- You can select up to 8 DMC devices.
- If you would not like to limit the DMCs for this TV, set **Access Control** to **Off**.
- Devices other than DMC may be displayed in the list. Confirm the MAC address of DMC and set it.

## Maximum Volume Setup

This feature allows you to set the maximum volume of the TV when it receives volume operation commands from a DMC.

- 1 **MENU** > **PREFERENCES** > **Media Renderer Setup** > **OK**.
- 2 Press **▲** or **▼** to highlight **Maximum Volume Setup**. Press **◀** or **▶** to adjust to the desired volume.

**Note:**

- The TV's remote control can set volume regardless of the value of Maximum Volume Setup.
- When DMR playback is ended, the TV volume will return to the value in effect when DMR playback was started.

## Using the Media Player

This TV allows you to enjoy photos, movies or music files stored on a USB device or SD Memory Card. Moreover, you can also play photos, movies or music files from your PC by connecting the TV to your home network. There are two ways to play contents.

Term meaning:

- DMP: DLNA CERTIFIED™ Player
- DMS: DLNA CERTIFIED™ Server
- DMR: DLNA CERTIFIED™ Renderer
- DMC: DLNA CERTIFIED™ Controller

- DMP: The TV can control and play a content on a DMS.
  - DMS is a device which has a server function to DMP or DMR.
- DMR: The TV can play content on a DMS. The playback is controlled by a DMC.
  - DMC is a device which can command the TV to display contents.

**Note:**

- Do not insert/remove USB device or SD Memory Card while in use.
- **MENU** is not available during playback.
- When you want to use your TV as DMR, set **Media Renderer** to **On** (☞ “Media Renderer” on p. 67).

## Media Player Specifications

### Device

USB device:  
USB Mass Storage Class devices (MSC)

**Note:**

- Connectivity is not guaranteed for all devices.
- Incorrect behavior may occur with a USB HUB connection.

SD Memory Card:  
SD Memory Card: up to 2GB  
SD High Capacity Memory Card (SDHC): 4 - 32GB

**Note:** Use only the specified SD memory cards.

DLNA CERTIFIED™ Server:  
Your PC (for example)

### Supported file system

FAT12, FAT16 and FAT32

You must obtain any required permission from copyright owners to download or use copyrighted content. Toshiba cannot and does not grant such permission.

## Basic operation

### Using Media Player with USB and SD Memory Card

When Auto Start is enabled, you will be asked if you want to start the Media Player whenever a USB or SD device is inserted. If Auto Start is disabled (or if you want to connect to a DMS on the network), you must manually start the Media Player from the menu.

To change the Auto Start setting:

- 1 **MENU** > **APPLICATIONS** > **Media Player** > **OK**.
- 2 Press **▲** or **▼** to select **Setup**. Press **OK**.
- 3 Press **▲** or **▼** to highlight **USB/SD Auto Start**. Press **◀** or **▶** to select **On** or **Off**.

Auto Start:

- 1 Insert USB device into the **USB** terminal or SD Memory Card into the **SD card slot** on the right side of the TV. A prompt appears.
- 2 Press **◀** or **▶** to select **Yes**. Press **OK**.
- 3 Press **▲** or **▼** to select **Photo**, **Movie** or **Music**. Press **OK**. The thumbnail view appears.
- 4 Press **▲** or **▼** to select USB device or SD Memory Card if the selection screen appears.

**Note:** If **Auto Start** is set to **Off**, you can start the Media Player manually.

Manual Start:

- 1 Insert USB device into the **USB** terminal or SD Memory Card into the **SD card slot** on the right side of the TV.
- 2 **MENU** > **APPLICATIONS** > **Media Player** > **OK**.
- 3 Press **▲** or **▼** to select **Photo**, **Movie** or **Music**. Press **OK**. The thumbnail appears.
- 4 Press **▲** or **▼** to select USB device or SD Memory Card if the selection screen appears.

To select a file in the list of contents:

- 1 Press **▲**, **▼**, **◀** or **▶** to select a file or folder.
- 2 Press **OK** to move to the next layer, or press **RETURN** to return to the previous layer.

To close the Media Player:

Press **EXIT**. The TV will return to the last-viewed channel or video input.

### Using Media Player with DLNA CERTIFIED™ Server

You need to configure a home network before using this feature (see p. 22).

- 1 **MENU** > **APPLICATIONS** > **Media Player** > **OK**.
- 2 Press **▲** or **▼** to select **Photo**, **Movie**, or **Music**. Press **OK**. The thumbnail (for Photo) or list of files (for Movie and Music) appear.
- 3 If there is more than one media server on the network, a list of all media servers will be displayed. Select the server you want to use, and press **OK**. Press **▲** or **▼** to select DMS if the selection window is displayed.

To select a file in the list of contents:

- 1 Press **▲**, **▼**, **◀** or **▶** to select a file or folder.
- 2 Press **OK** to move to the next layer, or press **RETURN** to return to the previous layer.

To close the Media Player:

Press **EXIT**. The TV will return to the last-viewed channel or video input.

To display the device information:

- 1 Press **QUICK** to open the Quick menu in list mode or Multi View mode.
- 2 Press **▲** or **▼** to select **Device Information**.

### Setting DLNA CERTIFIED™ Server waking up

You only need to complete the Media Server Setup if you wish to use the "Wake-on-LAN" feature.

- 1 **MENU** > **APPLICATIONS** > **Media Player** > **OK**.
- 2 Press **▲** or **▼** to select **Setup**. Press **OK**.
- 3 Press **▲** or **▼** to select **Media Server Setup**. Press **OK**. The list that contains the currently active DMSs and the registered DMSs appears.
- 4 Press **▲** or **▼** to select the desired device. Press **OK**. The box is selected. To clear the selection, press **OK**.
- 5 Press **▶** to select **Done**. Press **OK**.

**Note:**

- The setting is not saved when **RETURN** is pressed before **Done** is pressed.
- Up to 8 DMSs can be selected.
- Even if the device checked is powered off, it will be displayed but grayed out in the Select Device window. When **OK** is pressed on a highlighted grayed out item, a confirmation of Wake-on-LAN is displayed. The TV tries to wake up the DMS if **Yes** is pressed. The Server will start if it supports Wake-on-LAN feature.
- Depending on the hardware/software configuration of the Media Server, it may not start even if Wake-on-LAN is sent.
- When some DMSs are connected, it may take time until the list is displayed. The list may be refreshed by the following operation.
  - The device selection window is closed once and it is displayed again.
  - The **RED** button is pressed.

## Viewing Movie files

### Basic Playback:

- 1 Select a file (⏏ “To select a file in the list of contents” on p. 68). Press **OK** or **PLAY** to begin playback.

**Note:**

- When you highlight the file without pressing **OK**, the content is played on a preview screen. When **OK** is pressed, it is played in the full screen mode.
- Depending on the file size, it may take some time to start playback.

- 2 Press **STOP** to stop playback.
- 3 If playback finishes before **STOP** is pressed, the screen returns to the list.

**Note:** When the repeat mode is set to **All**, the next file will start playing automatically.

### To pause playback:

Press **PAUSE/STEP** during playback.  
To resume normal playback, press **PLAY**.

**Note:**

- You can move to the desired replay position by pressing **◀** or **▶** during PAUSE.
- PAUSE or operations during PAUSE may not be able to operate depending on contents, DMC or DMS.

### To play in fast reverse or fast forward directions:

Press **REW** or **FF** during playback. Each time you press **REW** or **FF**, the playback speed changes.

- **REW**: Fast reverse playback
- **FF**: Fast forward playback

### To locate a specific file:

Press **SKIP** or **SKIP** repeatedly to access the desired file.

- **SKIP**: Playback starts from the beginning of the current file. When you press this button twice quickly, playback starts from the beginning of the previous file.
- **SKIP**: To locate subsequent files.

**Note:**

- If the previous or next file is not compatible, it is skipped automatically.
- When the TV is used as a DMR, this feature is not available.
- These features may not be able to be operated depending on the contents, DMC or DMS.

### To select a language:

If subtitle or audio information is available in the video file, you can select it.

- 1 Press **CC** during playback.
- 2 Press **▲** or **▼** to select **Subtitle** or **Audio**.
- 3 Press **◀** or **▶** to select your preferred language.

### To set the repeat mode:

- 1 Press **QUICK**. The current repeat setting appears.
- 2 Press **◀** or **▶** to select **Off**, **All** or **1**.
- 3 Press **RETURN**. The setting is effective until the TV is turned off.

| Mode | Description   |
|------|---|
| Off  | The content is played back only once.                   |
| All  | Contents in the same folder are repeatedly played back. |
| 1    | The same content is repeatedly played back.             |

**Note:** When the TV is used as a DMR, this feature is not available.

### To sort the folders and files:

- 1 Press **QUICK** to open the Quick menu in list mode.
- 2 Press **▲** or **▼** to select **Sort**.
- 3 Press **◀** or **▶** to select **File Name(Title)**, **New** or **Old** to set the sorting rule.

| Item                           | Description   |
|--------------------------------|---|
| File Name (USB or SD card)     | File Name (Title)--File sorting rules:<br>1. Unicode priority   |
| Title (DLNA CERTIFIED™ Server) | 2. (0, 1, ..., 9), capital alphabet (A, B, ..., Z), small alphabet (a, b, ..., z), Chinese<br>3. Increasing order |
| New                            | From new to old according to the date and time when the contents were updated.                                    |
| Old                            | From old to new according to the date and time when the contents were updated.                                    |

**Note:** Sorting may not be supported by the DMS you are connected to.

To display the file status information:

- 1 Press during playback. The information will be displayed on the bottom of the screen.
- 2 Press again to hide the information.

**Note:** The information may not be correctly displayed depending on contents, DMC or DMS.

To use AVCHD device:

If the selected device includes AVCHD contents, the selection screen (Digital Video Camera or other) will appear. If a user selects Digital Video Camera, AVCHD list will appear.

### File specifications:

#### USB or SD card use

File format: MPEG2 PS, MPEG2 TS, AVCHD, MP4  
 Video: MPEG2, MPEG4, H.264  
 Audio: MPEG1-Layer2 / MPEG1-Layer3 / AC3 / LPCM

Maximum number of files: 1000 per folder

#### Content on DLNA CERTIFIED™ Server

File format: MPEG2 PS, MPEG2 TS, AVCHD\*, MP4\*  
 Video: MPEG2(PAL) PAL, MPEG2(TS) PAL, MPEG2(PAL) NTSC, MPEG2(TS) NTSC, H.264\*  
 Audio: LPCM / MPEG1-Layer1 / MPEG1-Layer2 / MPEG2-Layer2 / AC3 / AAC

Maximum number of files: 1000 per folder

\* Some files may not be played.

## Playing Music file

### Basic Playback:

- 1 Select a file (p. 68). Press or to begin playback.

**Note:** Depending on the file size, it takes some time to start playback.

- 2 Press to stop playback. If playback finishes before is pressed, the next file will start playing automatically.

### To pause playback:

Press during playback. To resume normal playback, press .

#### Note:

- You can move to the desired replay position by pressing or during PAUSE.
- PAUSE or operations during PAUSE may not be able to operate depending on contents, DMC or DMS.

### To play in fast reverse or fast forward directions:

Press or during playback. Each time you press or , the playback speed changes.

- : Fast reverse playback
- : Fast forward playback

**Note:** This feature is not controlled by DMC.

### To locate a specific file:

Press or repeatedly to access the desired file.

- : Playback starts from the beginning of the current file. When you press this button twice quickly, playback starts from the beginning of the previous file.
- : To locate subsequent files.

#### Note:

- If the previous or next file is not compatible, it is skipped automatically.
- When the TV is used as a DMR, this feature is not available.

**To set the repeat mode:**

- 1 Press **QUICK**. The current repeat setting appears.
- 2 Press **◀** or **▶** to select **Off**, **All** or **1**.
- 3 Press **RETURN**. The setting is effective until the TV is turned off.

| Mode | Description   |
|------|---|
| Off  | Contents in the same folder are played back once.       |
| All  | Contents in the same folder are repeatedly played back. |
| 1    | The same content is repeatedly played back.             |

**Note:** When the TV is used as a DMR, this feature is not available.

**To sort the folders and files:**

- 1 Press **QUICK** to open the Quick menu in the list mode.
- 2 Press **▲** or **▼** to select **Sort**.
- 3 Press **◀** or **▶** to select **File Name(Title)**, **New** or **Old** to set the sorting rule.

| Item  | Description  |
|---|--|
| File Name (USB or SD card)<br>Title(DLNA CERTIFIED™ Server) | File Name (Title)--File sorting rules:<br>1. Unicode priority<br>2. (0, 1, ..., 9), capital alphabet (A, B, ..., Z), small alphabet (a, b, ..., z), Chinese<br>3. Increasing order |
| New   | From new to old according to the date and time when the contents were updated.   |
| Old   | From old to new according to the date and time when the contents were updated.   |

**Note:** Sorting may not be supported by the DMS you are connected to.

**To display the file status information:**

- 1 Press **INFO** during playback. The information will be displayed on the bottom of the screen.
- 2 Press **INFO** again to hide the information.

**Note:** The information may not be correctly displayed depending on contents, DMC or DMS.

**File specifications:**

**USB or SD card use**

File format: MP3, MP4 (AAC), LPCM  
 Sampling frequency: 32 kHz, 44.1 kHz, 48 kHz  
 Bit rate: from 32 to 320 kbps  
 Maximum number of files: 1000 per folder

**Content on DLNA CERTIFIED™ Server**

File format: MP3, LPCM  
 Sampling frequency: 32 kHz, 44.1 kHz, 48 kHz  
 Bit rate: from 32 to 320 kbps  
 Maximum number of files: 1000 per folder



## Viewing Photo files

### Multi View mode:

This view mode allows you to search for photos in a grid format.

These pictures are displayed using thumbnail data in each image file.

- 1 Press ▲, ▼, ◀ or ▶ to move the highlight in one window.
  - If all of the photos will not fit in one screen, when pressing ◀ at the top left thumbnail, the screen will move to the previous page. Conversely, when pressing ▶ at the bottom right thumbnail, the screen will move to the next page.
- 2 When you select a folder, press (OK) to move to the next layer. Press (RETURN) to move back to the previous layer.
- 3 Press (OK) to view the selected photo in Single View mode.

**Note:** When the TV is used as a DMR, this feature is not available.

### Single View mode:

In this view mode, only files located in the selected directory are displayed. When moving from Multi View mode to the Single View mode, the currently selected photo is displayed.

- 1 On Multi view mode, press ▲, ▼, ◀ or ▶ to select a file. Press (OK).
- 2 Press ◀ or ▶ to view the next file or previous file.

### Note:

- If the previous or next file is not compatible, it will be skipped automatically.
- Single view mode is changed to Multi View mode when (RETURN) is pressed.

### Slideshow mode:

This view allows you to watch a slideshow of the photos. In this mode, only files located in the selected directory will be played.

- 1 To switch to Slideshow mode, press (OK) while in Single View mode. To return to Single View mode, press (OK) again.
- 2 Press ◀ or ▶ to view the next file or previous file.

**Note:** If the previous or next file is not compatible, it is skipped automatically.

**Note:** When the TV is used as a DMR, this feature is not available.

To sort the folders and files:

- 1 Press (QUICK) to open the Quick menu from Multi View mode.
- 2 Press ▲ or ▼ to select **Sort**.
- 3 Press ◀ or ▶ to select **File Name(Title), New** or **Old** to set the sorting rule.

| Item   | Description  |
|--|--|
| File Name (USB or SD card)<br>Title (DLNA CERTIFIED™ Server) | File Name (Title)--File sorting rules:<br>1. Unicode priority<br>2. (0, 1, ..., 9), capital alphabet (A, B, ..., Z), small alphabet (a, b, ..., z), Chinese<br>3. Increasing order |
| New  | From new to old according to the date and time when the contents were updated.   |
| Old  | From old to new according to the date and time when the contents were updated.   |

**Note:** Sorting may not be supported by the DMS you are connected to.

To set the mode settings:

- 1 Press (QUICK) to open the Quick menu while in Single View mode or Slideshow mode.
- 2 Press ▲ or ▼ to select the item (**PICTURE, Picture Size, Interval Time** or **Repeat**).
- 3 Press ◀ or ▶ to adjust the setting.
- 4 Press (RETURN) to return to Single View mode or Slideshow mode.

| Item          | Description  |
|---------------|--|
| Interval Time | Sets a time interval to view photos at your preferred interval (3sec, 5sec, 10sec, 15sec, 30sec, 60sec, or 90sec). |
| Repeat        | Displays photos in the same directory repeatedly. On/Off   |

To set the background Music:

- 1 Press (QUICK) to open the Quick menu while in Slideshow mode.
- 2 Press ▲ or ▼ to select **Background Music**. Press (OK).
- 3 Highlight **Background Music**. Press ◀ or ▶ to select **On**.
- 4 Press ▼ to select **Select Music**. Press (OK).
- 5 Select a music.

### Note:

- The music must be selected from the same media (USB or SD) device or DMS from which the picture files will be played.
- This feature is not available when there is no music that can be selected.

**To rotate the image:**

While viewing the image in Single View mode or Slideshow mode, press ▲ to rotate the image 90 degrees clockwise, press ▼ to rotate the image 90 degrees counterclockwise.

**Note:** When the TV is used as a DMR, this feature is not available.

**To return to the thumbnail:**

Press [RETURN] while in Single View mode or Slide Show mode.

**To display file status information:**

- 1 Press [INFO]. The information will be displayed on the bottom of the screen.
- 2 Press [INFO] again to hide the information.

**Note:** The information may not be correctly displayed depending on contents, DMC or DMS.

**File specifications:**

**USB or SD card use**

Data compatibility: JPEG Exif ver 2.2

File format: JPEG

Maximum viewable resolution:

4096 × 4096 (HW decode)

16384 × 16384 (SW decode)

Maximum photo size: 9 MB

Maximum number of files: 2000 / folder

**Content on DLNA CERTIFIED™ Server**

Data compatibility: JPEG EXIF Ver.1.x or later, JFIF 1.02a

File format: JPEG

Maximum photo resolution: 4096 x 4096

Maximum photo size: 6 MB

Maximum number of files: 2000 per folder

**Using the Photo Frame feature**

This feature allows you to display a photo file stored on the TV.

- Only one photo file can be stored on the TV.
- The photo file can be overwritten with a file from an external device (USB, SD Memory Card, DMS).

- 1 Press [MENU] > **PREFERENCES** > **Photo Frame Setup** > [OK]. The preview screen will appear.
- 2 Press ▶ to select **Start**. Press [OK].

**To open from the Quick menu**

- 1 Press [QUICK] to open the Quick menu.
- 2 Press ▲ or ▼ to select **Photo Frame**. Press [OK] to start **Photo Frame**.

**To close the Photo Frame:**

Press [EXIT].

**Photo Select**

- 1 Press [MENU] > **PREFERENCES** > **Photo Frame Setup** > [OK]. The preview screen will appear.
- 2 Press ▲ or ▼ to select **Photo Select**. Press [OK]. The device selection screen appears.  
**Note:** This screen will not appear when there is only one device connected.
- 3 Press ▲ or ▼ to select the appropriate device. Press [OK].
- 4 Press ▲, ▼, ◀ or ▶ to select the photo you want to copy from the USB storage device or SD card to the TV. Press [OK].

**Photo Edit**

- 1 Press [MENU] > **PREFERENCES** > **Photo Frame Setup** > [OK]. The preview screen appears.
- 2 Press ▲ or ▼ to select **Photo Edit**. Press [OK].
- 3 Press ▲ or ▼ to select **Rotate** or **Delete**.
- 4 Set the following items as required.
  - Rotate - Press [OK] to rotate the image 90° clockwise.
  - Delete - Press [OK], and select **YES**. Press [OK].
- 5 Press [EXIT].

## Auto Power Off

- 1 **MENU** > **PREFERENCES** > **Photo Frame Setup** > **OK**. The preview screen appears.
- 2 Press **▲** or **▼** to highlight **Auto Power Off**.
- 3 Press **◀** or **▶** to select Off, 00:30, 01:00, 02:00, 04:00, 06:00 or 12:00.
  - *If the Photo Frame window is left open, the TV will automatically turn off after the set length of time (maximum 12 hours).*
- 4 Press **EXIT**.

# Chapter 9: Troubleshooting

## General troubleshooting

Before calling a service technician, please check this chapter for a possible cause of the problem and some solutions you can try.

### Black box onscreen

- The closed caption feature is set to one of the Text modes (**T1**, **T2**, **T3**, or **T4**). Set the closed caption feature to **Off** (☞ p. 34).

### TV stops responding to controls

- If the TV stops responding to the remote control or TV control panel and you cannot turn off the TV, press and hold the **POWER** button on the TV control panel for 5 or more seconds to reset the TV.

### Other problems

- If your TV's problem is not addressed in this Troubleshooting section or the recommended solution has not worked, use the Reset Factory Defaults procedure (☞ p. 44).

### TV will not turn on

- Ensure the power cord is plugged in. Press **POWER**.
- Replace the remote control's batteries.
- Try the control panel buttons.

### Picture problems

#### General picture problems

- Check the antenna/cable connections (☞ Chapter 2).
- Press **(INPUT)** on the remote control or the TV and select a valid video input source (☞ p. 33). If no device is connected to a particular input on the TV, no picture appears when you select that particular input source. For device connection details, see Chapter 2.
- Antenna reception may be poor. Use a highly directional outdoor antenna (if applicable).
- The station may have broadcast difficulties. Try another channel.
- Adjust the picture qualities (☞ p. 48).

#### Video Input Selection problems

- If the **Input Selection** window does not appear when you press **(INPUT)** on the remote control or the TV control panel, press **(INPUT)** a second time. The TV displays the next video input source and the **Input Selection** screen.

#### Cannot view external signals or channel 3 or 4

- If you cannot view signals from external devices connected to **VIDEO 1**, **VIDEO 2**, **ColorStream HD1**, **ColorStream HD2**, **HDMI 1**, **HDMI 2**, **HDMI 3**, **HDMI 4**, **PC** or from channels 3 or 4, ensure the **Input Lock** is set to **Off** (☞ p. 37).

#### Poor color or no color

- The station may have broadcast difficulties. Try another channel.
- Check the Input mode when you use Shared Inputs (☞ p. 30).
- Adjust the **Tint** and/or **Color** (☞ p. 48).

#### Poor composite picture

- If the TV is connected to an external A/V device (e.g. DVD player, video game system, set-top box, etc.) try using a **ColorStream** or **HDMI** video connection instead.

#### Picture and sound are out of sync

- As with all products that contain a digital display, this may occur in rare instances, when viewing certain content (e.g. television broadcasts, video games, DVDs). The cause may include, without limitation, video processing within the TV, video processing in an attached gaming system, and video processing or different compression rates used by broadcasters in their programming. Try these procedures:
  - If the TV is connected to an A/V receiver that has a programmable audio delay feature, use this feature to help synchronize the sound to the picture.
  - If the problem occurs only on certain TV channels, inform your local broadcast, cable, or satellite provider.

### Sound problems

- Check the antenna/cable connections (☞ Chapter 2).
- The station may have broadcast difficulties. Try another channel.
- The sound may be muted. Press **VOLUME**.
- If you hear no sound, try setting the **MTS** feature to **Stereo** mode (☞ p. 53).
- If you are not receiving a second audio program from a known SAP source, make sure the **MTS** feature is set to **SAP** mode (☞ p. 53).
- If you hear audio that seems incorrect for the program you are watching (such as music or a foreign language), the SAP mode may be on. Set the **MTS** feature to **Stereo** mode (☞ p. 53).
- If you connect a PC using either the **PC IN** terminal or an **HDMI** terminal, ensure that the **Side Shared Audio** setting is properly set (☞ p. 41).

### Remote control problems

- Ensure the remote control is set to the correct device mode (☞ p. 85).
- Remove all obstructions between the remote control and the TV.
- Replace the remote control's batteries (☞ p. 23).
- Your TV's remote control may not operate certain features on your external device. Refer to the owner's manual for your other device to determine its available features. If your TV remote control does not operate a specific feature on another device, use the remote control that came with the device (☞ p. 88–93).
- If the TV still does not act as expected, use the Reset Factory Defaults procedure (☞ p. 44).

### Channel tuning problems

- Ensure the remote control is set to the correct device mode (☞ p. 85).
- The **Auto Tuning** feature may have erased the channel from memory. Add the channel to the channel memory (☞ p. 28).
- The **Lock** feature may have blocked the channel. Unblock the channel (☞ p. 37).

- If you cannot tune digital channels, check the antenna configuration (☞ p. 28). If the problem persists, clear all channels from the channel list and reprogram channels into memory (☞ p. 28). If the problem persists, use the Reset Factory Defaults procedure (☞ p. 44). See “TV stops responding to controls” and “Other problems” (☞ p. 76).

### Closed caption problems

- If the program or video you selected is not closed-captioned, no captions appear.
- If text is not available, a black rectangle may appear. If this happens, turn off the closed-caption feature (☞ p. 34).
- A closed-caption signal may not display correctly under these circumstances: a) the videotape is dubbed; b) the signal reception is weak; or c) the signal reception is nonstandard (☞ p. 34).

### Rating blocking (V-Chip) problems

- If you forget your PIN code: While the PIN code entering screen is displayed, press **INFO** 4 times within 5 seconds. The old PIN code clears (☞ p. 35).
- The V-Chip feature is available for the U.S. V-Chip system only (☞ p. 35).

### No REGZA-LINK operation

- The REGZA-LINK feature is available for Toshiba REGZA-LINK compatible devices.
- Ensure HDMI cables with the HDMI Logo (**HDMI**) are used.
- When the connected REGZA-LINK device does not work correctly after you changed the device’s settings, turn off your TV and unplug the power cord, then plug and turn on again.
- If several devices are connected, the REGZA-LINK feature may not operate properly.
- Read the instruction manual furnished with the connected REGZA-LINK device.

### HDMI problems

#### For HDMI cables

- Ensure HDMI cables with the HDMI Logo (**HDMI**) are used (☞ p. 14).

#### For Legacy HDMI sources

- Some legacy HDMI sources may not work properly with the latest HDMI TV products due to new standard. Turn off these HDMI settings (Content Type and INSTAPORT™) (☞ p. 40).

### Network problems

#### Cannot connect to the Internet

- Check the modem and its incoming cable/telephone connections (☞ p. 22).
- Confirm your modem’s operation.
- Ensure your IP address is set up correctly.

#### No network connection

- If using a wired network connection, check to ensure the LAN cables are connected properly (☞ p. 22).
- Ensure the modem and router power cords are plugged in and the devices are operating properly.

- Ensure your IP address is set up correctly. See Section (☞ “Setting up the Network”).
- Check to ensure proper operation of other network connected devices.

#### Network Setup fails (Auto)

- Check to ensure the LAN cables are connected properly (☞ p. 22).
- DHCP is not enabled on the router, or no router is present. Refer to your router’s documentation for instructions on enabling DHCP. If you do not have a router, you must manually set up the IP address.
- Internet service is not available. Check your cable/DSL modem or contact your ISP for Internet service issues.

#### Network Setup fails (Manual)

- Ensure the TV IP address is not the same as any other device on the network.  
Example: IP address 192.168.0.100 and IP address 192.168.0.101 are different addresses on the same network.
- Make sure the TV IP address is on the same subnet as the networked PC.  
Example of proper setup: The PC has IP address 192.168.0.100 with Subnet mask 255.255.255.0, the TV has IP address 192.168.0.101 with Subnet mask 255.255.255.0; both are on same subnet.  
Example of improper setup: The PC has IP address 192.168.1.100 with Subnet mask 255.255.255.0, the TV has IP address 192.168.0.101 with Subnet mask 255.255.253.0; they are on different sub-nets.

#### Unstable network connection

- When using a wired home-network connection, unplug the LAN cables, and then reconnect them.
- When using a wireless home-network connection:
  - Remove AC power from the router and the television for 30 seconds.
    - Reconnect AC power to the router.
    - Reconnect AC power to the television and power it ON. After 2 minutes, check connection stability.
  - Connect with LAN cables, if possible, and check connection stability.
  - Repeat the wireless network setup procedure and check connection stability.

#### The DMS name is not displayed

- The LAN cables, if used, are not connected properly (☞ p. 22).
- The WLAN, if used, is not configured properly.
- The network setup on the Server is incorrect. Make sure both the DMS and TV are using the same network type (DHCP/manual) and have compatible network settings.
- Too many DMSs are connected. You cannot connect more than 32 sharing devices at one time.
- The DMS is not turned ON.
- The “server” is not a DMS device.
- Check the firewall and streaming settings on the DMS.

### Wireless network problems

- Check that the router/AP (Access point) power is ON.
- After starting wireless network setup, confirm that the network is configured properly by performing the network connection test (☞ p. 59).
- Check the router/AP’s connection status (☞ p. 58).

(continued)

- If the router/AP does not support PBC or WPS, Easy Setup (PBC) will not work even if the push-button is pressed.
- If available router/AP list is not displayed in Easy Setup (PIN) or Assisted Setup, the power of router/AP may be OFF. Check that it is ON, and then try re-starting the scan for available routers/APs.
- Refer to the router/AP instruction manual.

### NET TV or Widget problems

- If the date and time display on the NET TV menu is wrong, turn off the TV, and turn it on again.
- NET TV or Widgets may not be available after turning the TV on while the system is booting.
- NET TV and Widgets are not available if Game or PC mode is selected on the TV.
- Content delivered by NET TV or Widgets are the responsibility of the Contents Service Provider. Contact the Service Provider to discuss any content issues.

### Media Player problems

- Ensure that the devices (Display and Server) are connected correctly.
- Incorrect behavior may occur when using a USB HUB connection.
- The size of pictures stored in the DMS may be automatically changed by the DMS and improperly displayed. This is a result of the DMS.
- Photo files that were processed and edited by using PC's application software may not be able to be viewed.
- When viewing content that supports two or more formats the display may select one format automatically.
- Copyright protected contents stored in the DMS may not be able to be played on the display.
- Content playback stability may be affected by heavy network traffic.
- Contents originally recorded on a PC may not play correctly.
- Set the media sharing of the DMS correctly, according to the DMS instruction manual.
- Confirm that the contents of either the DMS or the USB storage device are in formats that are supported by this TV (☞ p. 71, 72, or 74).
- Depending on the DMS, access may be limited by the MAC address. Set the server according to the DMS's instruction manual. This TV's MAC Address can be confirmed in the Network Setup portion of the User Menu (☞ p. 59).

#### For DLNA CERTIFIED™ Player

- Depending on the DMS, it may take time to display the list.

#### For DLNA CERTIFIED™ Renderer

- Depending the state of this TV, DMC may not be able to control a DMR playback.
- If DMR playback starts regardless of the user's intention, check the access control of DMS or set **Media Renderer to Off**.

## LED indications

The POWER and On Timer LED lights on the front of the TV indicate the TV's status, as described below.

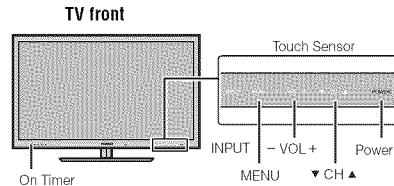

### Touch Sensor (POWER LED)

- **Blue**  
The TV is operating properly.
- **No light**  
The power is off or the TV is in standby.
- **Blue blinks**  
Fan Stopped. Turn off the TV and unplug the power cord. Plug the power cord in again and turn on the TV.
- **Red blinks**  
Power-On Failure. Turn off the TV and unplug the power cord. Plug the power cord in again and turn on the TV.

**Note:** To adjust the brightness of the POWER LED, see "Adjusting POWER LED's Dimmer" (☞ p. 43).

### Touch Sensor (except POWER LED)

- **White**  
Sensor is available.

### On Timer LED

- **Green is ON (solid)**  
On Timer is set.
- **Green blinks (if applicable)**  
Abnormal operation of BUS line. Turn off the TV and unplug the power cord. Plug the power cord in again and turn on the TV.

After trying the solutions, if the problem persists:

- In the U.S., visit TACP Consumer Solutions on the web at [www.tacp.toshiba.com/customersupport/](http://www.tacp.toshiba.com/customersupport/) or call 1-800-631-3811.
- In Canada, locate the nearest Toshiba authorized service depot by directing your web browser to [www.toshiba.ca](http://www.toshiba.ca); click "Home Entertainment," and then click "Support."

# Chapter 10: Appendix

## Specifications

### Note:

- *This model complies with the specifications listed below.*
- *Designs and specifications are subject to change without notice.*
- *This model may not be compatible with features and/or specifications that may be added in the future.*

### Television System

NTSC standard  
ATSC standard (8VSB)  
Digital Cable (64 QAM, 256 QAM; in-the-clear, unencrypted)

### Channel Coverage

VHF: 2 through 13  
UHF: 14 through 69  
Cable TV: Mid band (A-8 through A-1, A through I)  
Super band (J through W)  
Hyper band (AA through ZZ, AAA, BBB)  
Ultra band (65 through 94, 100 through 135)

### Power Source

120 V AC, 60 Hz

### Power Consumption

46VX700U: 1.4 A (rms) (maximum current)  
0.12 W in standby mode  
55VX700U: 1.6 A (rms) (maximum current)  
0.10 W in standby mode

### Audio Power

Main: 10 W + 10 W  
Woofers: 10W

### Speaker Type

Main: Two 1-3/8 × 2-3/4 inches (35 × 70 mm)  
Woofers: 2-1/8 inches (55 mm)

### Video/Audio Terminals

#### VIDEO/AUDIO INPUT:

VIDEO: 1 V(p-p), 75 ohm, negative sync.  
AUDIO: 200 mV(rms) (-20dBFS)

#### ColorStream® (component video) HD INPUT:

VIDEO: Y: 1V(p-p), 75 ohm  
PR: 0.7 V(p-p), 75 ohm  
PB: 0.7 V(p-p), 75 ohm  
Suggested formats: 1080p, 1080i, 720p, 480p, 480i

AUDIO: 200 mV(rms), 22 k ohm or greater

#### HDMI® INPUT:

HDMI compliant  
HDCP compliant

Suggested formats: See table on p. 81.

HDMI Audio: 2-channel Linear-PCM; 32/44.1/48 kHz sampling frequency; 16/20/24 bits per sample

#### DIGITAL AUDIO OUTPUT:

Optical type

#### IR IN/OUT:

3 V(p-p), 3.5 mm mono socket

#### PC INPUT:

15-Pin D-sub Analog RGB

### Dimensions (include foot stand)

46VX700U: Width: 43 inches (1,092 mm)  
Height: 28-15/16 inches (735 mm)  
Depth: 11-11/32 inches (288 mm)  
55VX700U: Width: 50-17/32 inches (1,283 mm)  
Height: 33-9/16 inches (852 mm)  
Depth: 14-1/32 inches (356 mm)

### Mass (weight)

46VX700U: 54.1 lbs (24.5 kg)  
55VX700U: 73.9 lbs (33.5 kg)

### Operating conditions

Temperature: 32°F - 95°F (0°C - 35°C)  
Humidity: 20 - 80% (no moisture condensation)

### Wireless connection

- Standard: IEEE 802.11a/b/g/n
- Host Interface: USB2.0 compatible
- Frequency Range: 5.15–5.35 GHz, 5.47–5.725 GHz, 5.725–5.850 GHz, 2.412–2.462 GHz
- Security: WEP64/128, TKIP, AES, WPA/WPA2-PSK, WPS, None

### Supplied Accessories

- Owner's manual (this book)
- Pedestal assembly installation manual
- Stop/Quick set up guide
- Cleaning cloth's manual
- Remote control with two size "AA" carbon zinc batteries
- Securement Clip  
Use this clip to attach the TV to a wall stud, pillar, or other immovable structure. See item 25 on p. 4 and instructions on p. 5.
- Cleaning cloth (to clean the cabinet and control panel)
- Tool set
- Four Spacers  
Use these to attach a wall bracket. See p. 5.
- Two Cable clamps
- AV adapter cable
- Component adapter cable
- Registration card TACP

## Acceptable signal formats for PC IN and HDMI terminals

### PC IN signal formats

**Note:**

- The PC IN on this TV only accepts signal formats which are compliant with VESA-DMT as in the table below. Since some PCs' input signals which are different from the resolution and frequency described in the table below, these phenomena occur; incorrect display, false format detection, picture position failure, blur, or judder. In this case, set the monitor output format on your PC to conform to any signals in the table below.
- The signals whose vertical frequency are 56 Hz, 70 Hz, 72 Hz, or 75 Hz are converted to 60 Hz signal.
- When you connect a PC to this TV, it is recommended to set the refresh rate of your PC to 60 Hz.
- The PC IN on this TV does not accept the Sync on Green, Composite Sync and Interlace signals.

| Format | Resolution  | V. Frequency | H. Frequency      | Pixel Clock Frequency | VESA Standard (DMT) |
|--------|-------------|--------------|-------------------|-----------------------|---------------------|
| VGA    | 640 × 480   | 59.940/60 Hz | 31.469/31.500 kHz | 25.175/25.200 MHz     | ●                   |
|        |             | 72.809 Hz    | 37.861 kHz        | 31.500 MHz            | ●                   |
|        |             | 75.000 Hz    | 37.500 kHz        | 31.500 MHz            | ●                   |
| SVGA   | 800 × 600   | 56.250 Hz    | 35.156 kHz        | 36.000 MHz            | ●                   |
|        |             | 60.317 Hz    | 37.879 kHz        | 40.000 MHz            | ●                   |
|        |             | 72.188 Hz    | 48.077 kHz        | 50.000 MHz            | ●                   |
|        |             | 75.000 Hz    | 46.875 kHz        | 49.500 MHz            | ●                   |
| XGA    | 1024 × 768  | 60.004 Hz    | 48.363 kHz        | 65.000 MHz            | ●                   |
|        |             | 70.069 Hz    | 56.476 kHz        | 75.000 MHz            | ●                   |
|        |             | 75.029 Hz    | 60.023 kHz        | 78.750 MHz            | ●                   |
| WXGA   | 1280 × 768  | 59.995 Hz    | 47.396 kHz        | 68.250 MHz            | ●                   |
|        |             | 59.870 Hz    | 47.776 kHz        | 79.500 MHz            | ●                   |
|        |             | 74.893 Hz    | 60.289 kHz        | 102.250 MHz           | ●                   |
|        | 1360 × 768  | 60.015 Hz    | 47.712 kHz        | 85.500 MHz            | ●                   |
| SXGA   | 1280 × 1024 | 60.020 Hz    | 63.981 kHz        | 108.000 MHz           | ●                   |
|        |             | 75.025 Hz    | 79.976 kHz        | 135.000 MHz           | ●                   |



## HDMI signal formats

**Note:**

- The HDMI inputs on this TV only accept VGA, SVGA, XGA, WXGA, and SXGA signal formats which are compliant with VESA as in the table below. Since some PCs' and HDMI or DVI devices input signals are different from the resolution and frequency described in the table below, these phenomena occur: incorrect display, false format detection, picture position failure, blur, or judder. In this case, set the monitor output format on your PC, HDMI or DVI device to conform to any signals in the table below.
- The signals whose vertical frequency are 24 Hz, 56 Hz, 70 Hz, 72 Hz, or 75 Hz are converted to 60 Hz signal.
- When you connect a PC to this TV, it is recommended to set the refresh rate of your PC to 60 Hz.

| Format | Resolution   | V. Frequency | H. Frequency      | Pixel Clock Frequency | VESA Standard |
|--------|--------------|--------------|-------------------|-----------------------|---------------|
| VGA    | 640 × 480    | 59.940 Hz    | 31.469 kHz        | 25.175 MHz            | ●             |
|        |              | 72.809 Hz    | 37.861 kHz        | 31.500 MHz            | ●             |
|        |              | 75.000 Hz    | 37.500 kHz        | 31.500 MHz            | ●             |
| SVGA   | 800 × 600    | 56.250 Hz    | 35.156 kHz        | 36.000 MHz            | ●             |
|        |              | 60.317 Hz    | 37.879 kHz        | 40.000 MHz            | ●             |
|        |              | 72.188 Hz    | 48.077 kHz        | 50.000 MHz            | ●             |
|        |              | 75.000 Hz    | 46.875 kHz        | 49.500 MHz            | ●             |
| XGA    | 1024 × 768   | 60.004 Hz    | 48.363 kHz        | 65.000 MHz            | ●             |
|        |              | 70.069 Hz    | 56.476 kHz        | 75.000 MHz            | ●             |
|        |              | 75.029 Hz    | 60.023 kHz        | 78.750 MHz            | ●             |
| WXGA   | 1280 × 768   | 59.995 Hz    | 47.396 kHz        | 68.250 MHz            | ●             |
|        |              | 59.870 Hz    | 47.776 kHz        | 79.500 MHz            | ●             |
|        |              | 74.893 Hz    | 60.289 kHz        | 102.250 MHz           | ●             |
|        | 1360 × 768   | 60.015 Hz    | 47.712 kHz        | 85.500 MHz            | ●             |
| SXGA   | 1280 × 1024  | 60.020 Hz    | 63.981 kHz        | 108.000 MHz           | ●             |
|        |              | 75.000 Hz    | 79.976 kHz        | 135.000 MHz           | ●             |
| 480i   | 720 × 480i   | 59.940/60 Hz | 15.734/15.750 kHz | 27.000/27.027 MHz     |               |
| 480p   | 720 × 480p   | 59.940/60 Hz | 31.469/31.500 kHz | 27.000/27.027 MHz     |               |
| 720p   | 1280 × 720p  | 59.940/60 Hz | 44.955/45.000 kHz | 74.176/74.250 MHz     |               |
| 1080i  | 1920 × 1080i | 59.940/60 Hz | 33.716/33.750 kHz | 74.176/74.250 MHz     |               |
| 1080p  | 1920 × 1080p | 23.976/24 Hz | 26.973/27.000 kHz | 74.176/74.250 MHz     |               |
|        |              | 59.940/60 Hz | 67.433/67.500 kHz | 148.352/148.500 MHz   |               |

## Remote control functional key chart

| REMOTE CONTROL KEY | Toshiba TV                           | CABLE             | SAT (satellite)   | Blu-Ray           | DVD/VCR Combo DVD/DVD-R | VCR    | PVR               | Receiver/AMP | CD    |
|--------------------|--------------------------------------|-------------------|-------------------|-------------------|-------------------------|--------|-------------------|--------------|-------|
| LIGHT              | Lights the remote control keys*1     |                   |                   |                   |                         |        |                   |              |       |
| SLEEP              | (TV) Sleep                           |                   |                   |                   |                         |        |                   |              |       |
| POWER              | Power                                |                   |                   |                   |                         |        |                   |              |       |
| MODE SELECT        | Remote control device mode selection |                   |                   |                   |                         |        |                   |              |       |
| 1                  | 1                                    | 1                 | 1                 | 1                 | 1                       | 1      | 1                 | AV input 1   | 1     |
| 2                  | 2                                    | 2                 | 2                 | 2                 | 2                       | 2      | 2                 | AV input 2   | 2     |
| 3                  | 3                                    | 3                 | 3                 | 3                 | 3                       | 3      | 3                 | AV input 3   | 3     |
| 4                  | 4                                    | 4                 | 4                 | 4                 | 4                       | 4      | 4                 | AV input 4   | 4     |
| 5                  | 5                                    | 5                 | 5                 | 5                 | 5                       | 5      | 5                 | CD           | 5     |
| 6                  | 6                                    | 6                 | 6                 | 6                 | 6                       | 6      | 6                 | Tuner        | 6     |
| 7                  | 7                                    | 7                 | 7                 | 7                 | 7                       | 7      | 7                 | Phono        | 7     |
| 8                  | 8                                    | 8                 | 8                 | 8                 | 8                       | 8      | 8                 | Cassette     | 8     |
| 9                  | 9                                    | 9                 | 9                 | 9                 | 9                       | 9      | 9                 | AUX          | 9     |
| 0                  | 0                                    | 0                 | 0                 | 0                 | 0                       | 0      | 0                 | ---          | 0     |
| - /100/ +10        | – (digital separator)                | ---               | -/--, +10, +100   | -/--, +10, +100   | -/--, +10, +100         | +100   | ---               | ---          | ---   |
| INPUT              | (TV) Input                           |                   |                   |                   |                         |        |                   | Input        | Input |
| ▲ / ▼              | Menu select up/down                  | Cursor up/down    | Cursor up/down    | Cursor up/down    | Cursor up/down          | ---    | Cursor up/down    | ---          | ---   |
| ◀ / ▶              | Menu select left/right               | Cursor left/right | Cursor left/right | Cursor left/right | Cursor left/right       | ---    | Cursor left/right | ---          | ---   |
| OK                 | OK                                   | Select            | Select            | Select            | Select                  | ---    | Select            | ---          | ---   |
| NET TV/ TOP MENU   | NET TV                               | ---               | ---               | Top Menu          | Top Menu                | ---    | ---               | ---          | ---   |
| Y! WIDGETS         | Yahoo! TV Widgets                    | ---               | ---               | ---               | ---                     | ---    | ---               | ---          | ---   |
| Menu/ DVD MENU     | Menu                                 | Menu, Cable Menu  | Menu, Action Menu | DVD Menu, Menu    | DVD Menu, Menu          | ---    | Menu              | Menu         | Menu  |
| MUTE               | Mute                                 | Mute*2            | Mute*2            | Mute*2            | Mute*2                  | Mute*2 | Mute*2            | Mute         | Mute  |
| GUIDE              | Guide                                | Guide             | Guide             | ---               | Guide                   | ---    | Guide             | ---          | ---   |
| CH RTN             | Last channel                         | Last channel      | Last channel      | ---               | ---                     | ---    | ---               | ---          | ---   |

## Chapter 10: Appendix

| REMOTE CONTROL KEY | Toshiba TV            | CABLE                 | SAT (satellite)       | Blu-Ray           | DVD/VCR Combo DVD/DVD-R | VCR                   | PVR                   | Receiver/AMP    | CD             |
|--------------------|-----------------------|-----------------------|-----------------------|-------------------|-------------------------|-----------------------|-----------------------|-----------------|----------------|
| VOL +/-            | Volume up/down        | Volume up/down *2     | Volume up/down *2     | Volume up/down *2 | Volume up/down *2       | Volume up/down *2     | Volume up/down *2     | Volume up/down  | Volume up/down |
| CH▲▼               | Channel up/down       | Channel up/down       | Channel up/down       | ---               | Channel up/down         | Channel up/down       | Channel up/down       | Channel up/down | ---            |
| EXIT/DVD CLEAR     | Exit                  | Exit                  | Exit                  | Clear             | Clear                   | ---                   | Exit                  | ---             | ---            |
| FAV/SET UP         | FAV Browser           | ---                   | ---                   | Setup             | Setup                   | ---                   | ---                   | ---             | ---            |
| QUICK              | Quick Menu            | ---                   | ---                   | ---               | ---                     | ---                   | ---                   | ---             | ---            |
| RETURN/DVD RETURN  | Return                | ---                   | ---                   | Return            | Return, DVD Return      | ---                   | ---                   | ---             | ---            |
| INFO               | (TV) Info             |                       |                       |                   |                         |                       |                       |                 |                |
| PAUSE/STEP         | Pause*3               | Pause                 | Pause                 | Pause             | Pause                   | Pause                 | Pause                 | ---             | Pause          |
| PLAY               | Play*3                | Play                  | Play                  | Play              | Play                    | Play                  | Play                  | ---             | Play           |
| STOP               | Stop*3                | Stop                  | Stop                  | Stop              | Stop                    | Stop                  | Stop                  | ---             | Stop           |
| SKIP ◀◀            | Skip REW/DAY- *3      | ---                   | ---                   | Skip REW          | Skip REW                | ---                   | ---                   | ---             | Skip REW       |
| SKIP ▶▶            | Skip FWD/DAY+ *3      | ---                   | ---                   | Skip FWD          | Skip FWD                | ---                   | ---                   | ---             | Skip FWD       |
| REW                | Rewind*3              | Rewind                | Rewind                | Rewind            | Rewind                  | Rewind                | Rewind                | ---             | Rewind         |
| FF                 | Fast Forward*3        | Fast Forward          | Fast Forward          | Fast Forward      | Fast Forward            | Fast Forward          | Fast Forward          | ---             | Fast Forward   |
| EJECT              | Eject                 | ---                   | ---                   | Open/Close, Eject | Open/Close, Eject       | ---                   | ---                   | ---             | Eject          |
| REC                | Record (Single click) | Record (Single click) | Record (Single click) | ---               | Record (Double click)*4 | Record (Double click) | Record (Double click) | ---             | ---            |
| SLOW/DIR-          | Slow/DIR-             | ---                   | ---                   | Slow REW          | Slow REW                | Slow REW              | Slow REW              | ---             | ---            |
| SLOW/DIR+          | Slow/DIR+             | ---                   | ---                   | Slow FWD          | Slow FWD                | Slow FWD              | Slow FWD              | ---             | ---            |
| FREEZE             | (TV) Freeze           |                       |                       |                   |                         |                       |                       |                 |                |
| PIC SIZE           | (TV) Picture size     |                       |                       |                   |                         |                       |                       |                 |                |
| MTS/AUDIO          | MTS                   | ---                   | ---                   | Audio             | Audio                   | ---                   | ---                   | ---             | ---            |
| CC/SUBTITLE        | C. Caption            | ---                   | ---                   | Subtitle          | Subtitle                | ---                   | ---                   | ---             | ---            |
| RED                | Red                   | ---                   | ---                   | Red               | ---                     | ---                   | ---                   | ---             | ---            |
| GREEN              | Green                 | ---                   | ---                   | Green             | ---                     | ---                   | ---                   | ---             | ---            |
| YELLOW             | Yellow                | ---                   | ---                   | Yellow            | ---                     | ---                   | ---                   | ---             | ---            |

| REMOTE CONTROL KEY | Toshiba TV | CABLE | SAT (satellite) | Blu-Ray | DVD/VCR Combo DVD/DVD-R | VCR | PVR | Receiver/AMP | CD  |
|--------------------|------------|-------|-----------------|---------|-------------------------|-----|-----|--------------|-----|
| BLUE/HOME          | Blue/Home  | ---   | ---             | Blue    | ---                     | --- | --- | ---          | --- |

**Note:**

- “---” = key does not send a signal in that remote control mode.
- \*1 Does not send IR signal.
- \*2 Volume affects the TV by default. When the volume is unlocked, each device has its own volume if its ID has volume data. The AUDIO modes will have their own volume if volume lock is set on TV, CABLE/SAT, VCR/PVR, or DVD mode. See “Locking the volume keys” (p. 86).
- \*3 This function is available for only REGZA-LINK® (p. 38) and Media Player.
- \*4 DVD: REC is only for DVD Recorder, no function is selected for DVD Player.

## Operating other devices

Your TV remote control has one dedicated TV mode and five programmable multi-brand modes: **CABLE/SAT**, **BD**, **DVD**, **VCR/PVR** and **AUX**.

**Note:** To operate a non-Toshiba device or a Toshiba device that the remote control is not preprogrammed to operate, you must program the remote.

| Mode select | Default device mode control (before programming) |
|-------------|--|
| TV          | Toshiba TV                                       |
| CABLE/SAT   | Toshiba Satellite receiver                       |
| BD          | Toshiba BD player                                |
| DVD         | Toshiba DVD                                      |
| VCR/PVR     | Toshiba VCR                                      |
| AUX         | Onkyo Receiver                                   |

| Mode select | Device mode control (after programming) |
|-------------|---|
| TV          | Toshiba TV                              |
| CABLE/SAT   | Multi-brand video/audio devices         |
| BD          |   |
| DVD         |   |
| VCR/PVR     |   |
| AUX         |   |

**Note:** If you cannot program the TV's remote to operate your device or some of its features, use the device's remote or the controls on the device.

## Programming the remote to operate other devices

### Device code setup

- 1 Find the code for your device brand in the remote control device code table (p. 88–93). If multiple codes are listed, try each one separately until you find one that works.
- 2 Press and hold a mode select button (**CABLE/SAT**, **BD**, **DVD**, **VCR/PVR** or **AUX**), until the button blinks 3 times.
- 3 While holding down **INFO**, press the 5-digit code for your device.

| Result       | Meaning      |
|--------------|--------------|
| 2 blinks     | Valid code   |
| 1 long blink | Invalid code |

- 4 Point the remote at the device. Press to test the code.

| Result                       | Meaning  |
|------------------------------|--|
| The device responds.         | Valid code   |
| The device does not respond. | Invalid code<br>Repeat the procedure, using another code |

- 5 When programming is complete, test all necessary keys on the TV's remote that operate your device. If some keys are not operational, repeat the device code setup using another code (if other codes are listed for your device).
- 6 To control the TV, press TV.
- 7 If your VCR does not respond to the codes for your VCR brand, and has a switch labeled VCR1/VCR2, set the switch to the other position. Reprogram the remote control.

**Note:** Every time you change the batteries, you must reprogram the remote.

## Searching for a device code

If you do not know the device code for a particular device, you can view each available code for that device mode and sample the functions to find the code that operates the target device.

- 1 Press a mode select button on the remote.
- 2 While holding down **INFO**, press **8, 5, 0, 0**. The remote control enters program mode.
- 3 Point the remote at the target device and press **POWER**, **1**, **(VOL+)**, **(CH)** or **PLAY**. Some keys are ignored if they are not applicable to a specific device mode.
- 4 If the device responds to the remote control: Press **INFO** to store the device code. The mode select button blinks twice. The remote exits program mode.
- 5 If the device does not respond to the remote control: Press **▲**. Press **POWER**. Repeat this step until the device responds to the remote. Press **INFO**.

**Note:** When a search cycle is completed, the mode select button blinks 3 times. The remote displays each available code again. If no key is pressed within 10 seconds, the remote exits program mode and returns to the previous code.

## Locking the volume keys

By default, the remote's volume keys (**(VOL+)**, **(VOL-)**, and **MUTE**) are locked to the TV device mode.

| State                            | Meaning   |
|----------------------------------|---|
| Locked                           | The remote operates the TV's volume, even when the TV is not the current device mode.   |
| Unlocked                         | The remote operates the volume of the device associated with the current device mode. Each device mode has its own volume (if the device ID has volume data). |
| Locked to a specific device mode | The remote operates the volume of the device associated with the locked mode, even when the locked mode is not the current device mode.                       |

See "Operating other devices" (p. 85).

To lock the remote's volume keys to a specific mode:  
Example: CABLE/SAT mode

- 1 Press CABLE/SAT.
- 2 While holding down the **INFO** button, press **8, 0, 0, 0**.
- 3 Press **(VOL+)**. The CABLE/SAT mode select button blinks 2 times (locked).  
The remote's volume keys now operate the volume of the device associated with the CABLE/SAT mode, even when CABLE/SAT is not the current device mode.

To unlock the remote's volume keys:

- 1 While holding down **INFO**, press **8, 0, 0, 0**.
- 2 Press **(VOL+)**. The CABLE/SAT mode select button blinks 4 times.  
The CABLE/SAT mode is unlocked.

## Clearing the remote's programming

You can clear all programmed remote control features not related to "Device code setup" and reset the volume lock to the TV device mode.

While holding down **INFO**, press **8, 9, 0, 0**. The mode select button blinks 4 times.

## Resetting to the factory default

You can clear changed manufacturing features.

While holding down **INFO**, press **8, 9, 0, 1**. The mode select button blinks 4 times.

## Operating TV with combination buttons

You can directly operate the TV power, input switch, picture size switch and picture mode switch with pressing a combination button while holding down a color button.

| Color button | Combination button    | Behavior/Mode                |
|--------------|-----------------------|------------------------------|
| RED          | SLEEP                 | Power Off                    |
|              | POWER                 | Power On                     |
|              | 1                     | Video 1                      |
|              | 2                     | Video 2                      |
|              | 3                     | ColorStream HD1              |
|              | 4                     | ColorSteram HD 2             |
|              | 5                     | HDMI 1                       |
|              | 6                     | HDMI 2                       |
|              | 7                     | HDMI 3                       |
| GREEN        | 8                     | HDMI 4                       |
|              | 9                     | PC                           |
|              | 1                     | Native (Picture Size)        |
|              | 2                     | 4:3 (Picture Size)           |
|              | 3                     | TheaterWide 1 (Picture Size) |
|              | 4                     | TheaterWide 2 (Picture Size) |
|              | 5                     | TheaterWide 3 (Picture Size) |
|              | 6                     | Full (Picture Size)          |
| 7            | Normal (Picture Size) |                              |
| YELLOW       | 8                     | Dot by Dot (Picture Size)    |
|              | 1                     | AutoView (Picture Mode)      |
|              | 2                     | Sports(Picture Mode)         |
|              | 3                     | Standard (Picture Mode)      |
|              | 4                     | Movie 1 (Picture Mode)       |
|              | 5                     | Store (Picture Mode)         |
|              | 6                     | Game (Picture Mode)          |
| 7            | PC (Picture Mode)     |                              |

## Remote control codes

In some cases, you may not be able to operate your device with the TV remote control. Your device may use a code that is not recognized by the TV remote control. If this happens, use the device's remote control.

### Audio - Amplifier

| Brand             | Code                |
|-------------------|---------------------|
| Anthem            | 42220               |
| Cary Audio Design | 41879               |
| Denon             | 42134               |
| Elan              | 40647               |
| Flextronics       | 41879               |
| Halcro            | 41934               |
| Harman/Kardon     | 40892               |
| Krell             | 41837, 42463        |
| Left Coast        | 40892               |
| Lexicon           | 41802               |
| Marantz           | 40892, 41892, 42138 |
| Mark Levinson     | 42405               |
| McIntosh          | 40251               |
| Optimus           | 40823               |
| Parasound         | 41934               |
| Philips           | 40892               |
| Pioneer           | 40823               |
| Polk Audio        | 40892, 42242        |
| Primare           | 41851               |
| RCA               | 40823               |
| Thule Audio       | 41851               |

### Cable Set Top Box

| Brand        | Code                              |
|--------------|-----------------------------------|
| ADB          | 12254                             |
| Amino        | 11602, 11481, 11822, 12482        |
| AT&T         | 10858                             |
| Bright House | 11376, 11877                      |
| Cable One    | 11376, 11877                      |
| Cablevision  | 11376, 11877, 11006               |
| Charter      | 11376, 11877, 12187               |
| Cisco        | 11877, 10877, 10858, 11982, 12345 |
| Comcast      | 11376, 11877, 11982, 12576        |
| Cox          | 11376, 11877                      |
| Digeo        | 11187, 12187                      |

|                    |   |
|--------------------|---|
| Director           | 10476   |
| General Instrument | 10476   |
| Homecast           | 12301   |
| i3 Micro           | 11602   |
| Insight            | 11376, 11877                                    |
| Jerrold            | 10476   |
| Knology            | 11877   |
| KoolConnect        | 11481   |
| Mediacom           | 11376, 11877                                    |
| Motorola           | 11376, 10476, 11187, 10858, 11982, 12378, 12694 |
| Myrio              | 11602, 11822                                    |
| Pace               | 11376, 11877, 11982                             |
| Panasonic          | 11982   |
| Pioneer            | 11877, 10877                                    |
| RCA                | 11256   |
| RCN                | 12694   |
| Rogers             | 11877   |
| Samsung            | 11877   |
| Scientific Atlanta | 11877, 10877, 10858, 11982, 12345               |
| Sejin              | 11602   |
| Shaw               | 11376   |
| Sony               | 11006   |
| Suddenlink         | 11376, 11877                                    |
| SureWest           | 11481   |
| Thomson            | 11256, 11982                                    |
| Time Warner        | 11376, 11877, 12187                             |
| Tivo               | 12576   |
| Verizon            | 12378   |
| WideOpenWest       | 11877   |

### Cable/PVR Combo

| Brand        | Code                       |
|--------------|----------------------------|
| Amino        | 11822                      |
| Bright House | 11376, 11877               |
| Cable One    | 11376, 11877               |
| Cablevision  | 11376, 11877, 11006        |
| Charter      | 11376, 11877, 12187        |
| Cisco        | 11877, 11982               |
| Comcast      | 11376, 11877, 11982, 12576 |
| Cox          | 11376, 11877               |
| Digeo        | 11187, 12187               |
| Homecast     | 12301                      |
| Insight      | 11376, 11877               |
| Knology      | 11877                      |
| Mediacom     | 11376, 11877               |
| Motorola     | 11376, 11187, 12694        |
| Myrio        | 11822                      |
| Pace         | 11877                      |

|                    |                     |
|--------------------|---------------------|
| Panasonic          | 11982               |
| Pioneer            | 11877               |
| RCA                | 11256               |
| RCN                | 12694               |
| Rogers             | 11877               |
| Samsung            | 11877               |
| Scientific Atlanta | 11877, 11982        |
| Shaw               | 11376               |
| Sony               | 11006               |
| Suddenlink         | 11376, 11877        |
| Thomson            | 11256               |
| Time Warner        | 11376, 11877, 12187 |
| Tivo               | 12576               |
| WideOpenWest       | 11877               |

### Audio - CD

| Brand                 | Code                       |
|-----------------------|----------------------------|
| Aiwa                  | 40157                      |
| Arcam                 | 40157                      |
| Burmester             | 40420                      |
| California Audio Labs | 40029, 40303               |
| Carver                | 40157                      |
| Denon                 | 40034                      |
| DKK                   | 40000                      |
| DMX Electronics       | 40157                      |
| Garrard               | 40420                      |
| Genexxa               | 40032                      |
| Harman/Kardon         | 40157, 40173               |
| Hitachi               | 40032                      |
| JVC                   | 40072                      |
| Kenwood               | 40028                      |
| KLH                   | 41711                      |
| Krell                 | 40157                      |
| Linn                  | 40157                      |
| Magnavox              | 40157                      |
| Marantz               | 40029, 40157               |
| McIntosh              | 40256                      |
| MCS                   | 40029                      |
| Miro                  | 40000                      |
| Mission               | 40157                      |
| MTC                   | 40420                      |
| Myryad                | 40157                      |
| NSM                   | 40157                      |
| Onkyo                 | 41327                      |
| Optimus               | 40000, 40032, 40420, 40468 |
| Panasonic             | 40029, 40303, 40388, 40752 |
| Parasound             | 40420                      |
| Philips               | 40157                      |
| Pioneer               | 41062, 40032, 41087, 40468 |
| Polk Audio            | 40157                      |
| Proceed               | 40420                      |
| Proton                | 40157                      |
| QED                   | 40157                      |



## Chapter 10: Appendix

|                 |   |
|-----------------|---|
| Quad            | 40157                                   |
| Quasar          | 40029                                   |
| RCA             | 41062, 40032,<br>40053, 40420,<br>40468 |
| Realistic       | 40420                                   |
| Rotel           | 40157, 40420                            |
| SAE             | 40157                                   |
| Sansui          | 40157                                   |
| Sonic Frontiers | 40157                                   |
| Sony            | 40490, 40000,<br>40100, 41364,<br>40185 |
| TAG McLaren     | 40157                                   |
| Tascam          | 40420                                   |
| Teac            | 40420                                   |
| Technics        | 40029, 40303                            |
| Victor          | 40072                                   |
| Wards           | 40157, 40053                            |
| Yamaha          | 40490, 41292                            |

### Audio - Accessory

| Brand  | Code                   |
|--------|------------------------|
| B & W  | 42441                  |
| Vizio  | 42454                  |
| Yamaha | 42021, 42116,<br>42458 |
| ZVOX   | 42334                  |

### Audio - Receiver

| Brand                | Code                          |
|----------------------|-------------------------------|
| Aiwa                 | 41405, 40189,<br>41388, 41641 |
| Akai                 | 41512                         |
| Alco                 | 41390                         |
| AMC                  | 41077                         |
| Amphion Media Works  | 41563                         |
| AMW                  | 41563                         |
| Anam                 | 41609                         |
| Apex Digital         | 41257, 41430,<br>41774        |
| Arcam                | 41189, 40189                  |
| Audiotronic          | 41189                         |
| Audiovox             | 41390                         |
| B & K                | 40820                         |
| Bose                 | 41229, 40639,<br>41933        |
| Cambridge Soundworks | 41370                         |
| Carver               | 41189, 40189                  |
| Coby                 | 41389                         |
| Curtis               | 41389                         |
| Daewoo               | 41250                         |
| Denon                | 42857, 41360,<br>42279        |
| Fisher               | 41801                         |
| Gateway              | 41517                         |

|               |   |
|---------------|---|
| Harman/Kardon | 40189, 41304,<br>41306, 42241,<br>42443   |
| Hitachi       | 41801   |
| iHome         | 42435   |
| iLive         | 42013   |
| Insignia      | 41030, 41077,<br>42126, 42169,<br>42175, 42472,<br>42474  |
| Integra       | 41805, 41298,<br>41320  |
| iSymphony     | 42018, 42258,<br>42442  |
| JBL           | 41306   |
| JVC           | 41374, 41495,<br>42040, 42239,<br>42331   |
| Kenwood       | 41313, 41570  |
| KLH           | 41390, 41428  |
| Koss          | 41366, 41497  |
| LG            | 41293, 42197,<br>42284  |
| Linn          | 40189   |
| Liquid Video  | 41497   |
| Magnavox      | 41189, 41269,<br>40189, 41514   |
| Marantz       | 41189, 41269,<br>40189, 41289,<br>42114   |
| McIntosh      | 41289   |
| Micromega     | 41189   |
| Mitsubishi    | 41393   |
| Myryad        | 41189   |
| Nakamichi     | 41313   |
| Norcent       | 41389   |
| Nova          | 41389   |
| Onkyo         | 42674, 41805,<br>40842, 41298,<br>41320, 41531,<br>42451  |
| Optimus       | 41023   |
| Oritron       | 41366, 41497  |
| Panasonic     | 41308, 41518,<br>41275, 41288,<br>41316, 41548,<br>41633, 41763,<br>41764, 42221,<br>42452, 42967 |
| Philips       | 41189, 41269,<br>42311, 40189,<br>41266, 42459  |
| Pioneer       | 41023, 41384,<br>41935  |
| Polaroid      | 41508   |
| Polk Audio    | 40189, 41289,<br>42270  |
| Proscan       | 41254   |
| RCA           | 41023, 41609,<br>41254, 41390,<br>41511, 42041  |
| Rio           | 41869   |

|                    |   |
|--------------------|---|
| Samsung            | 41868, 41295,<br>41304, 41500   |
| Sansui             | 40189   |
| Sanyo              | 41469, 41801  |
| Sherwood           | 41077, 41517,<br>41653, 41905,<br>42169   |
| Sherwood Newcastle | 42169   |
| Sonic Blue         | 41869   |
| Sony               | 41759, 41058,<br>41441, 41258,<br>41622, 41558,<br>41658, 41758,<br>41822, 41858,<br>42172, 42320,<br>42522 |
| Stereophonics      | 41023   |
| Sunfire            | 41313   |
| Teac               | 41390, 41528  |
| Technics           | 41308, 41518,<br>41633  |
| Thorens            | 41189   |
| Toshiba            | 41788   |
| Venturer           | 41390   |
| Vizio              | 41517   |
| Wards              | 40189   |
| Yamaha             | 42061, 40176,<br>40376, 41176,<br>41276, 41331,<br>41375, 41376,<br>41476, 42455,<br>42467, 42471           |
| Zenith             | 41293   |

### Satellite Set Top Box

| Brand              | Code   |
|--------------------|--|
| Bell ExpressVu     | 10775, 11170   |
| Coolsat            | 11806  |
| Crossdigital       | 11109  |
| DirecTV            | 11377, 10392,<br>10566, 10639,<br>11639, 11142,<br>10247, 10749,<br>11749, 10819,<br>11856, 11076,<br>10099, 11109,<br>11414, 11442,<br>11443, 11444,<br>11609 |
| Dish Network       | 10775, 11505,<br>11170, 11775  |
| Dishpro            | 10775, 11505,<br>11775   |
| Echostar           | 10775, 11505,<br>11170, 11775  |
| Expressvu          | 10775, 11775   |
| Fortec Star        | 11821  |
| GE                 | 10566  |
| General Instrument | 10869  |
| GOI                | 10775, 11775   |

|                        |  |
|------------------------|--|
| Hitachi                | 10819  |
| HTS                    | 10775, 11775   |
| Hughes Network Systems | 11142, 10749, 11749, 11442, 11443, 11444                             |
| Humax                  | 11790  |
| Jerrold                | 10869  |
| JVC                    | 10775, 11170, 11775  |
| LG                     | 11226, 11414   |
| Mitsubishi             | 10749  |
| Motorola               | 10869  |
| Next Level             | 10869  |
| Panasonic              | 10247, 10701   |
| Pansat                 | 11807  |
| Philips                | 11142, 10749, 11749, 11076, 10099, 11442                             |
| Proscan                | 10392, 10566   |
| RadioShack             | 10869  |
| RCA                    | 10392, 10566, 10143  |
| Samsung                | 11377, 11276, 11109, 11442, 11609                                    |
| Sonicview              | 12374, 12449   |
| Sony                   | 10639, 11639   |
| Star Choice            | 10869  |
| Tivo                   | 11142, 11442, 11443, 11444   |
| Toshiba                | 10749, 11749, 10790, 11285, 11286, 11287, 11289, 11857, 11858, 10819 |
| Ultrasat               | 11806  |
| Voom                   | 10869  |
| Zenith                 | 11856  |

**SAT/PVR Combo**

| Brand                  | Code  |
|------------------------|---|
| Bell ExpressVu         | 10775, 11170  |
| DirecTV                | 11377, 10392, 10639, 11142, 11076, 10099, 11442, 11443, 11444 |
| Dish Network           | 10775, 11505  |
| Dishpro                | 10775, 11505  |
| Echostar               | 10775, 11505, 11170   |
| Expressvu              | 10775   |
| Hughes Network Systems | 11142, 11442, 11443, 11444                                    |
| JVC                    | 11170   |
| Motorola               | 10869   |
| Philips                | 11142, 11442  |
| Proscan                | 10392   |
| Samsung                | 11442   |
| Sonicview              | 12374, 12449  |

|             |                            |
|-------------|----------------------------|
| Sony        | 10639                      |
| Star Choice | 10869                      |
| Tivo        | 11142, 11442, 11443, 11444 |

**TV**

| Brand   | Code  |
|---------|-------|
| Toshiba | 02724 |

**Video - VCR**

| Brand          | Code                                     |
|----------------|--|
| ABS            | 31972                                    |
| Accurian       | 30000                                    |
| Admiral        | 30048, 30479                             |
| Adventura      | 30000                                    |
| Aiwa           | 30037, 30000                             |
| Alienware      | 31972                                    |
| Allegro        | 30039, 31137                             |
| American High  | 30035                                    |
| Audiovox       | 30037                                    |
| Bell ExpressVu | 31944                                    |
| Bright House   | 32763                                    |
| Broksonic      | 30184, 30479                             |
| Cable One      | 32763                                    |
| Cablevision    | 32763                                    |
| Calix          | 30037                                    |
| Canon          | 30035                                    |
| Carver         | 30081                                    |
| Charter        | 32763                                    |
| CineVision     | 31137                                    |
| Citizen        | 30037                                    |
| Comcast        | 32448, 32763                             |
| Cox            | 32763                                    |
| Craig          | 30037                                    |
| Crosley        | 30081, 30000                             |
| Curtis Mathes  | 30060, 30035, 30162                      |
| CyberPower     | 31972                                    |
| Daewoo         | 30045, 31137                             |
| Dell           | 31972                                    |
| Denon          | 30042                                    |
| DirecTV        | 30739, 32033                             |
| Dish Network   | 31944                                    |
| Dishpro        | 31944                                    |
| Durabrand      | 30039, 30038                             |
| Dynatech       | 30000                                    |
| Echostar       | 31944                                    |
| Electrohome    | 30037, 30043                             |
| Electrohome    | 30037                                    |
| Emerex         | 30032                                    |
| Emerson        | 30037, 30184, 30000, 30043, 30479, 31593 |
| ESA            | 31137                                    |
| Expressvu      | 31944                                    |
| Fuji           | 30035, 30033                             |
| Funai          | 30000, 31593                             |

|                        |   |
|------------------------|---|
| Garrard                | 30000   |
| Gateway                | 31972   |
| GE                     | 30060, 30035  |
| GFM                    | 31593   |
| Go Video               | 30614, 31137  |
| GOI                    | 31944   |
| GoldStar               | 30037, 30038, 31137   |
| Gradiente              | 30000   |
| Harley Davidson        | 30000   |
| Harman/Kardon          | 30081, 30038  |
| Headquarter            | 30046   |
| Hewlett Packard        | 31972   |
| Hitachi                | 30000, 30042  |
| Howard Computers       | 31972   |
| HP                     | 31972   |
| HTS                    | 31944   |
| Hughes Network Systems | 30042   |
| Humax                  | 30739   |
| Hush                   | 31972   |
| iBUYPOWER              | 31972   |
| Insight                | 32763   |
| Instant Replay         | 30035   |
| JVC                    | 30067, 31944  |
| KEC                    | 30037   |
| Kenwood                | 30067, 30038  |
| Kodak                  | 30035, 30037  |
| LG                     | 31037, 31137  |
| Linksys                | 31972   |
| Lloyd's                | 30000   |
| LXI                    | 30037   |
| Magnavox               | 30035, 30039, 30081, 30000, 30563, 31593                      |
| Marantz                | 30035, 30081  |
| Marta                  | 30037   |
| Matsushita             | 30035, 30162  |
| Media Center PC        | 31972   |
| Mediacom               | 32763   |
| MEI                    | 30035   |
| Memorex                | 30035, 30162, 30037, 30048, 30039, 30000, 30046, 30479, 31037 |
| MGA                    | 30043   |
| Microsoft              | 31972   |
| Mind                   | 31972   |
| Minolta                | 30042   |
| Mitsubishi             | 30067, 30043  |
| Motorola               | 30035, 30048, 32763   |
| MTC                    | 30000   |
| Multitech              | 30000   |
| NEC                    | 30067, 30038  |
| Nikko                  | 30037   |
| Niveus Media           | 31972   |

|            |   |
|------------|---|
| Northgate  | 31972   |
| Olympus    | 30035   |
| Optimus    | 31062, 30162, 30037, 30048, 31048               |
| Orion      | 30184, 30479                                    |
| Pace       | 32763   |
| Panasonic  | 31062, 30035, 30162, 30614, 30616               |
| Penney     | 30035, 30037, 30042, 30038                      |
| Pentax     | 30042   |
| Philco     | 30035   |
| Philips    | 30739, 30035, 30081, 30618, 31081, 31181        |
| Pilot      | 30037   |
| Pioneer    | 30067   |
| Polk Audio | 30081   |
| Presidian  | 31593   |
| Proscan    | 30060   |
| Pulsar     | 30039   |
| Quarter    | 30046   |
| Quartz     | 30046   |
| Quasar     | 30035, 30162                                    |
| RadioShack | 30000, 31037                                    |
| Radix      | 30037   |
| Randex     | 30037   |
| RCA        | 30060, 30035, 30042, 30880                      |
| Realistic  | 30035, 30037, 30048, 30000, 30046               |
| ReplayTV   | 30614, 30616                                    |
| Ricavision | 31972   |
| Rio        | 31137   |
| Runco      | 30039   |
| Samsung    | 30045   |
| Sanky      | 30048, 30039                                    |
| Sansui     | 30000, 30067, 30479                             |
| Sanyo      | 30046   |
| Scott      | 30184, 30045, 30043, 30210                      |
| Sears      | 30035, 30037, 30000, 30042, 30046               |
| Sharp      | 30048, 30848                                    |
| Shaw       | 32763   |
| Signature  | 30035   |
| Sonic Blue | 30614, 30616, 31137                             |
| Sony       | 30032, 30035, 30033, 30000, 30636, 31032, 31972 |
| Stack 9    | 31972   |
| STS        | 30042   |
| Suddenlink | 32763   |

|                 |   |
|-----------------|---|
| Sylvania        | 30035, 30081, 30000, 30043, 31593   |
| Symphonic       | 30000, 31593  |
| Systemax        | 31972   |
| Tagar Systems   | 31972   |
| Tashiko         | 30037   |
| Teac            | 30000   |
| Technics        | 30035, 30162  |
| Teknika         | 30035, 30037, 30000   |
| Thomas          | 30000   |
| Time Warner     | 32763   |
| Tivo            | 30739, 30618, 30636, 31996, 32448   |
| Toshiba         | 30045, 30043, 30210, 31008, 31972, 31996                                    |
| Totevision      | 30037   |
| Touch           | 31972   |
| Vector          | 30045   |
| Vector Research | 30038   |
| Video Concepts  | 30045   |
| Videomagic      | 30037   |
| Viewsonic       | 31972   |
| Villain         | 30000   |
| Voodoo          | 31972   |
| Wards           | 30060, 30035, 30048, 30039, 30081, 30033, 30045, 30000, 30042, 30038, 30046 |
| XR-1000         | 30035, 30000  |
| Yamaha          | 30038   |
| Zenith          | 30037, 30039, 30033, 30000, 30479, 31137                                    |
| ZT Group        | 31972   |

**Cable/PVR Combo**

| Brand        | Code         |
|--------------|--------------|
| Bright House | 32763        |
| Cable One    | 32763        |
| Cablevision  | 32763        |
| Charter      | 32763        |
| Comcast      | 32448, 32763 |
| Cox          | 32763        |
| Insight      | 32763        |
| Mediacom     | 32763        |
| Motorola     | 32763        |
| Pace         | 32763        |
| Shaw         | 32763        |
| Suddenlink   | 32763        |
| Time Warner  | 32763        |
| Tivo         | 32448        |

**DVD/VCR Combo**

| Brand      | Code         |
|------------|--------------|
| Accurian   | 30000        |
| Allegro    | 31137        |
| CineVision | 31137        |
| Daewoo     | 31137        |
| Emerson    | 31593        |
| Funai      | 31593        |
| GFM        | 31593        |
| Go Video   | 31137        |
| GoldStar   | 31137        |
| Hitachi    | 30000        |
| LG         | 31137        |
| Magnavox   | 30000, 31593 |
| Presidian  | 31593        |
| RCA        | 30060        |
| Rio        | 31137        |
| Sharp      | 30848        |
| Sylvania   | 30000, 31593 |
| Symphonic  | 30000, 31593 |
| Zenith     | 31137        |

**PVR**

| Brand           | Code         |
|-----------------|--------------|
| ABS             | 31972        |
| Alienware       | 31972        |
| Bell ExpressVu  | 31944        |
| Bright House    | 32763        |
| Cable One       | 32763        |
| Cablevision     | 32763        |
| Charter         | 32763        |
| Comcast         | 32448, 32763 |
| Cox             | 32763        |
| CyberPower      | 31972        |
| Dell            | 31972        |
| DirecTV         | 30739, 32033 |
| Dish Network    | 31944        |
| Dishpro         | 31944        |
| Echostar        | 31944        |
| Expressvu       | 31944        |
| Gateway         | 31972        |
| Go Video        | 30614        |
| GOI             | 31944        |
| Hewlett Packard | 31972        |
| Howard          | 31972        |
| Computers       |              |
| HP              | 31972        |
| HTS             | 31944        |
| Humax           | 30739        |
| Hush            | 31972        |
| iBUYPOWER       | 31972        |
| Insight         | 32763        |
| JVC             | 31944        |
| Linksys         | 31972        |
| Media Center PC | 31972        |
| Mediacom        | 32763        |

## Chapter 10: Appendix

|               |                               |
|---------------|-------------------------------|
| Microsoft     | 31972                         |
| Mind          | 31972                         |
| Motorola      | 32763                         |
| Niveus Media  | 31972                         |
| Northgate     | 31972                         |
| Pace          | 32763                         |
| Panasonic     | 30614, 30616                  |
| Philips       | 30739, 30618                  |
| RCA           | 30880                         |
| ReplayTV      | 30614, 30616                  |
| Shaw          | 32763                         |
| Sonic Blue    | 30614, 30616                  |
| Sony          | 30636, 31972                  |
| Stack 9       | 31972                         |
| Suddenlink    | 32763                         |
| Systemax      | 31972                         |
| Tagar Systems | 31972                         |
| Time Warner   | 32763                         |
| Tivo          | 30739, 30618,<br>30636, 32448 |
| Toshiba       | 31008, 31972,<br>31996        |
| Touch         | 31972                         |
| Viewsonic     | 31972                         |
| Voodoo        | 31972                         |
| ZT Group      | 31972                         |

### SAT/PVR Combo

| Brand          | Code         |
|----------------|--------------|
| Bell ExpressVu | 31944        |
| DirecTV        | 30739, 32033 |
| Dish Network   | 31944        |
| Dishpro        | 31944        |
| Echostar       | 31944        |
| Expressvu      | 31944        |

### Video - DVD

| Brand                 | Code   |
|-----------------------|--|
| Accurian              | 20675, 21416   |
| Akai                  | 20695  |
| Alco                  | 20790  |
| Allegro               | 20869  |
| Apex Digital          | 20672, 20755,<br>20794, 20796,<br>20797, 21004,<br>21020, 21056,<br>21061, 21100,<br>22619 |
| Arrgo                 | 21023  |
| Audiovox              | 20790  |
| Bel Canto Design      | 21571  |
| Blue Parade           | 20571  |
| Broksonic             | 20695  |
| California Audio Labs | 20490  |
| CineVision            | 20869  |
| Citizen               | 20695, 22116   |

|               |  |
|---------------|--|
| Coby          | 21628  |
| Curtis Mathes | 21087  |
| CyberHome     | 20816, 21023,<br>21024, 21502                            |
| Daewoo        | 20784, 20869,<br>21172                                   |
| Denon         | 20490, 20634,<br>21634                                   |
| DigitalMax    | 21738  |
| Disney        | 20675, 21270   |
| Durabrand     | 21023  |
| Electrohome   | 22116  |
| Emerson       | 20675, 20591   |
| Enterprise    | 20591  |
| Fisher        | 20670  |
| Funai         | 20675  |
| Gateway       | 21077, 21158   |
| GE            | 20522  |
| GFM           | 20675  |
| Go Video      | 20741, 20744,<br>20783, 20869,<br>21044, 21075,<br>21158 |
| GoldStar      | 20741, 20869   |
| Grundig       | 20539  |
| Harman/Kardon | 20582, 20702,<br>21229                                   |
| Helios        | 22080, 22192   |
| Hitachi       | 20573, 20664   |
| Hiteker       | 20672  |
| Humax         | 21500, 21588   |
| iLo           | 21348  |
| Insignia      | 20675, 22095   |
| Integra       | 20571, 20627,<br>21634                                   |
| Irradio       | 20646  |
| JBL           | 20702  |
| JVC           | 20623, 20867,<br>21164, 21275,<br>21550                  |
| Kawasaki      | 20790  |
| Kenwood       | 20490, 20534   |
| KLH           | 20790, 21020   |
| LG            | 20741, 20591,<br>20869, 22135                            |
| LiteOn        | 21058, 21158,<br>21416, 21656,<br>21738                  |
| Logitech      | 22639  |
| Magnavox      | 20539, 20503,<br>20675, 20646,<br>21354, 21506           |
| Marantz       | 20539  |
| McIntosh      | 21273  |
| Memorex       | 20695, 21270,<br>22213                                   |
| Microsoft     | 20522  |
| Mitsubishi    | 21521  |
| NAD           | 20741  |
| NexxTech      | 21402  |

|                       |  |
|-----------------------|--|
| Onkyo                 | 20503, 20627,<br>22215   |
| Oppo                  | 20575, 22185   |
| Orion                 | 20503  |
| Panasonic             | 20490, 20503,<br>21579, 21762  |
| Philco                | 20675  |
| Philips               | 22056, 20539,<br>20503, 20675,<br>20646, 21158,<br>21267, 21340,<br>21354, 21506 |
| PianoDisc             | 21024  |
| Pioneer               | 20571, 20631,<br>21512, 21571  |
| Polaroid              | 21020, 21061   |
| Polk Audio            | 20539  |
| Presidian             | 20675, 21738   |
| Proceed               | 20672  |
| Proscan               | 20522  |
| RCA                   | 20522, 20571,<br>20790, 20822,<br>22213  |
| Rio                   | 20869  |
| Rotel                 | 20623  |
| Sampo                 | 20752  |
| Samsung               | 20573, 20490,<br>20820, 21044,<br>21075, 22069,<br>22329, 22369,<br>22489, 22556 |
| Sansui                | 20695  |
| Sanyo                 | 20670, 20695   |
| Schneider             | 20646  |
| Sensory Science       | 21158  |
| Sharp                 | 20675, 20630,<br>20752, 21256  |
| Sherwood              | 21077  |
| Sherwood<br>Newcastle | 21077  |
| Shinsonic             | 20533  |
| Sonic Blue            | 20869  |
| Sony                  | 21633, 20533,<br>20864, 20772,<br>21033, 21070,<br>21431, 21536                  |
| Sylvania              | 20675  |
| Symphonic             | 20675  |
| Teac                  | 20790  |
| Technics              | 20490  |
| Theta Digital         | 20571  |
| Tivo                  | 21503, 21512   |
| Toshiba               | 20503, 20695,<br>21154, 21503,<br>21510, 21588,<br>21608, 22006,<br>22277        |
| Urban Concepts        | 20503  |
| Venturer              | 20790  |
| Vizio                 | 21226  |
| Xbox                  | 20522  |

|        |   |
|--------|---|
| Yamaha | 20490, 20539,<br>20646, 20545,<br>20497, 20817,<br>21416, 22558 |
| Zenith | 20503, 20741,<br>20591, 20869                                   |

### DVD High Definition (Blu-Ray)

| Brand     | Code                   |
|-----------|------------------------|
| Denon     | 52258                  |
| Insignia  | 50675, 52428,<br>52596 |
| Integra   | 52147, 51769           |
| JVC       | 52365                  |
| LG        | 50741, 51602           |
| Magnavox  | 50675                  |
| Marantz   | 52414                  |
| Microsoft | 52083                  |
| NAD       | 52572                  |
| Olevia    | 52331                  |
| Onkyo     | 52147, 51769,<br>51612 |
| Oppo      | 52545                  |
| Panasonic | 51641                  |
| Philips   | 52084, 52434           |
| Pioneer   | 50142, 52442           |
| RCA       | 51769                  |
| Samsung   | 50199                  |
| Sharp     | 52250                  |
| Sony      | 51516                  |
| Sylvania  | 50675                  |
| Toshiba   | 52705                  |
| Viore     | 52553                  |
| Vizio     | 52563                  |
| Xbox      | 52083                  |
| Yamaha    | 52298                  |

### DVD High Definition (HD-DVD)

| Brand   | Code  |
|---------|-------|
| Toshiba | 51769 |

### DVD-R

| Brand        | Code         |
|--------------|--------------|
| Accurian     | 20675, 21416 |
| Apex Digital | 21056        |
| Citizen      | 22116        |
| CyberHome    | 21502        |
| DigitalMax   | 21738        |
| Electrohome  | 22116        |
| Funai        | 20675        |
| Gateway      | 21158        |
| Go Video     | 20741, 21158 |
| Humax        | 21588        |
| iLo          | 21348        |
| Irradio      | 20646        |
| JVC          | 21164, 21275 |

|                 |                               |
|-----------------|-------------------------------|
| LG              | 20741, 22135                  |
| LiteOn          | 21158, 21416,<br>21738        |
| Magnavox        | 20675, 20646,<br>21506        |
| Panasonic       | 20490, 21579                  |
| Philips         | 20646, 21340                  |
| Pioneer         | 20631, 21512                  |
| Presidian       | 21738                         |
| RCA             | 20522                         |
| Samsung         | 20490                         |
| Sanyo           | 20670                         |
| Sensory Science | 21158                         |
| Sharp           | 20675                         |
| Sony            | 21033, 21070,<br>21431, 21536 |
| Sylvania        | 20675                         |
| Toshiba         | 21510, 21588,<br>22277        |
| Zenith          | 20741                         |

|        |              |
|--------|--------------|
| Zenith | 20741, 20869 |
|--------|--------------|

### DVD/VCR Combo

| Brand        | Code                                    |
|--------------|---|
| Accurian     | 20675                                   |
| Allegro      | 20869                                   |
| Apex Digital | 21061                                   |
| Broksonic    | 20695                                   |
| CineVision   | 20869                                   |
| Daewoo       | 20869                                   |
| Emerson      | 20675                                   |
| Funai        | 20675                                   |
| GFM          | 20675                                   |
| Go Video     | 20741, 20744,<br>20869, 21044,<br>21075 |
| GoldStar     | 20741                                   |
| Hitachi      | 20664                                   |
| JVC          | 20867, 21164,<br>21550                  |
| LG           | 20741                                   |
| LiteOn       | 21656                                   |
| Magnavox     | 20675                                   |
| Memorex      | 20695                                   |
| Panasonic    | 21762                                   |
| Philips      | 20675, 21267                            |
| Polaroid     | 21061                                   |
| Presidian    | 20675                                   |
| RCA          | 20522, 20822                            |
| Samsung      | 20820, 21044,<br>21075, 22489           |
| Sansui       | 20695                                   |
| Sanyo        | 20670                                   |
| Sharp        | 20630                                   |
| Sony         | 20864, 21033,<br>21070, 21431           |
| Sylvania     | 20675                                   |
| Symphonic    | 20675                                   |
| Toshiba      | 20503                                   |

## Limited United States Warranty for LCD Televisions

Toshiba America Consumer Products, L.L.C. ("TACP") makes the following limited warranties to original consumers in the United States.

THESE LIMITED WARRANTIES EXTEND TO THE ORIGINAL CONSUMER PURCHASER OR ANY PERSON RECEIVING THIS LCD TELEVISION AS A GIFT FROM THE ORIGINAL CONSUMER PURCHASER AND TO NO OTHER PURCHASER OR TRANSFEREE. LCD TELEVISIONS PURCHASED IN THE U.S.A. AND USED ANYWHERE OUTSIDE OF THE U.S.A., INCLUDING, WITHOUT LIMITATION, CANADA AND MEXICO, ARE NOT COVERED BY THESE WARRANTIES. LCD TELEVISIONS PURCHASED ANYWHERE OUTSIDE OF THE U.S.A., INCLUDING, WITHOUT LIMITATION, CANADA AND MEXICO, AND USED IN THE U.S.A., ARE NOT COVERED BY THESE WARRANTIES.

### Limited One (1) Year Warranty on Parts and Labor

TACP WARRANTS THIS LCD TELEVISION AND ITS PARTS AGAINST DEFECTS IN MATERIALS OR WORKMANSHIP FOR A PERIOD OF ONE (1) YEAR FROM THE DATE OF ORIGINAL RETAIL PURCHASE. DURING THIS PERIOD, TACP WILL, AT TACP'S SOLE DISCRETION, REPAIR OR REPLACE A DEFECTIVE PART/PRODUCT WITH A NEW OR REFURBISHED PART/PRODUCT WITHOUT CHARGE TO YOU FOR PARTS OR LABOR. ANY PART OR PRODUCT REPLACED UNDER THIS LIMITED WARRANTY BECOMES THE PROPERTY OF TACP. IN SOME CASES, YOU MAY BE RESPONSIBLE FOR DELIVERING THE PRODUCT TO A SERVICE CENTER.

### Rental Units

Warranty period begins on the date of the first rental or thirty (30) days after the date of shipment to the rental firm, whichever comes first.

### Limited Warranty for Commercial Units

TACP warrants parts and labor for LCD Televisions that are sold and used for commercial purposes for a period of ninety (90) days after the date of original retail purchase. This warranty is void if the product is exposed to excessive temperature (heat/cold), moisture as outlined in the product's specification listed in the Owner's manual as well as exposure to excessive smoke, dust, or other airborne contaminants. All exclusions outlined in paragraph (4) and (5) under the "Your Responsibilities" section apply to commercial use.

### Your Responsibility

Read the owner's manual thoroughly before operating this LCD Television. Complete and mail the enclosed product registration card or register your LCD Television online at [www.tacp.toshiba.com/register](http://www.tacp.toshiba.com/register). Registration of your LCD Television will enable TACP to contact you in the unlikely event a safety notification is required under the U.S.

Consumer Product Safety Act. Failure to complete and return the product registration card does not diminish your warranty rights.

### THE ABOVE WARRANTIES ARE SUBJECT TO THE FOLLOWING CONDITIONS:

This Limited Warranty is extended only to the original purchaser and only covers product purchased as new.

- (1) A purchase receipt or other proof of the original purchase date is required for Warranty service.
- (2) All warranty servicing of this LCD Television must be performed by an Authorized TACP Service Station.
- (3) The warranties from TACP are effective only if this LCD Television is purchased and operated in the U.S.A. or Puerto Rico.
- (4) Removal and reinstallation of product that is mounted in such a manner as to impede normal service is not covered under these warranties. This includes wall mounts, custom cabinets and other installation methods that do not provide for direct and immediate access to the product for service purposes. Labor service charges for set installation, setup, adjustment of customer controls, and installation or repair of antenna, satellite or cable systems are not covered by this warranty. Reception problems caused by inadequate antenna systems, misaligned satellite dishes or improperly installed cable drops are your responsibility.
- (5) Warranties extend only to defects in materials or workmanship as limited above, and do not extend to any LCD Television or parts that have been lost or discarded by you or to damage to the LCD Television or parts caused by fires, misuse, abuse, accident, Acts of God (such as lightning or fluctuations in electric power), improper installation, improper maintenance, or use in violation of instructions furnished by TACP; use or malfunction through simultaneous use of this LCD Television and connected equipment; or to units that have been modified or had the serial number removed, altered, defaced, or rendered illegible.
- (6) Products purchased "AS-IS" or "With known faults, defects or problems" are not covered by this limited warranty. Product previously owned or registered by a consumer and resold is not covered by this limited warranty.
- (7) Product that is refurbished and resold is not covered under this warranty.

### How to Obtain Warranty Service

If, after following all of the operating instructions in this manual, review the section entitled "Concierge" located on our Customer Support Web site "[www.tacp.toshiba.com/customersupport](http://www.tacp.toshiba.com/customersupport)". If you find that service is needed, follow the instructions provided on the web site or please contact TACP's Consumer Solution Center toll free at 1-800-631-3811. You must present upon request your original bill of sale or other proof of purchase including the serial number for in warranty service.

ALL WARRANTIES IMPLIED BY THE LAW OF ANY STATE OF THE U.S.A., INCLUDING THE IMPLIED WARRANTIES OF MERCHANTABILITY AND FITNESS FOR A PARTICULAR PURPOSE, ARE EXPRESSLY LIMITED TO THE DURATION OF THE LIMITED WARRANTIES SET FORTH ABOVE. WITH THE EXCEPTION OF ANY WARRANTIES IMPLIED BY THE LAW OF ANY STATE OF THE U.S.A. AS HEREBY LIMITED, THE FOREGOING WARRANTY IS EXCLUSIVE AND IN LIEU OF ALL OTHER WARRANTIES, GUARANTEES, AGREEMENTS, AND SIMILAR OBLIGATIONS OF TACP WITH RESPECT TO THE REPAIR OR REPLACEMENT OF ANY PARTS. IN NO EVENT SHALL TACP BE LIABLE FOR CONSEQUENTIAL OR INCIDENTAL DAMAGES (INCLUDING, BUT NOT LIMITED TO, LOST PROFITS, BUSINESS INTERRUPTION, OR MODIFICATION OR ERASURE OF RECORDED DATA CAUSED BY USE, MISUSE OR INABILITY TO USE THIS LCD TELEVISION).

No person, agent, distributor, dealer or company is authorized to change, modify or extend the terms of these warranties in any manner whatsoever. The time within which an action must be commenced to enforce any obligation of TACP arising under the warranty or under any statute, or law of the United States or any state thereof, is hereby limited to ninety (90) days from the date you discover or should have discovered, the defect. This limitation does not apply to implied warranties arising under the law of any state of the U.S.A.

THIS WARRANTY GIVES YOU SPECIFIC LEGAL RIGHTS AND YOU MAY ALSO HAVE OTHER RIGHTS WHICH MAY VARY FROM STATE TO STATE IN THE U.S.A. SOME STATES OF THE U.S.A. DO NOT ALLOW LIMITATIONS ON THE DURATION OF AN IMPLIED WARRANTY, WHEN AN ACTION MAY BE BROUGHT, OR THE EXCLUSION OR LIMITATION OF INCIDENTAL OR CONSEQUENTIAL DAMAGES. THEREFORE, THE ABOVE PROVISIONS MAY NOT APPLY TO YOU UNDER SUCH CIRCUMSTANCES.

## Limited Canadian Warranty for Toshiba Brand Flat Panel Televisions

Toshiba of Canada Limited ("TCL") makes the following limited warranties to original consumers in Canada. THESE LIMITED WARRANTIES EXTEND TO THE ORIGINAL CONSUMER PURCHASER OR ANY PERSON RECEIVING THIS TOSHIBA BRAND FLAT PANEL TELEVISION (the "TELEVISION(S)" or "Television(s)") AS A GIFT FROM THE ORIGINAL CONSUMER PURCHASER AND TO NO OTHER PURCHASER OR TRANSFEREE.

TELEVISIONS PURCHASED IN CANADA, AND USED ANYWHERE OUTSIDE OF CANADA INCLUDING, WITHOUT LIMITATION, THE UNITED STATES AND MEXICO, ARE NOT COVERED BY THESE WARRANTIES.

TELEVISIONS PURCHASED ANYWHERE OUTSIDE OF CANADA, INCLUDING, WITHOUT LIMITATION, THE UNITED STATES AND MEXICO, AND USED IN CANADA, ARE NOT COVERED BY THESE WARRANTIES.

### Limited One (1) Year Warranty on Parts and Labour

TCL warrants the Television and its parts against material defects in materials or workmanship that result in the Television failing for a period of one (1) year after the date of original retail purchase. DURING THIS PERIOD, TCL WILL, AT TCL'S OPTION, REPAIR OR REPLACE A DEFECTIVE PART WITH A NEW OR RECERTIFIED PART WITHOUT CHARGE TO YOU FOR PARTS OR LABOUR.

### Rental Units

The warranty for Television rental units begins with the date of first rental or thirty (30) days from the date of shipment to the rental firm, whichever comes first.

### Your Responsibility

Read the owner's manual thoroughly before operating this LCD Television. Complete and mail the enclosed product registration card or register your LCD Television online at <http://support.toshiba.ca/warranty/>. Registration of your LCD Television will enable TCL to contact you in the unlikely event of a product safety notice. Failure to complete the product registration does not diminish your warranty rights.

THE ABOVE WARRANTIES ARE SUBJECT TO THE FOLLOWING CONDITIONS:

- (1) You must provide your bill of sale or other proof of purchase.
- (2) All warranty servicing of this Television must be performed by a Toshiba Authorized Service Provider (ASP).
- (3) The warranties from TCL are effective only if the Television is (i) purchased as new and unopened from TCL or from TCL's authorized distributors, dealers or resellers ("ADR's") and (ii) located/operated in Canada.
- (4) Removal and reinstallation of product that is mounted in such a manner as to impede normal service is not covered under these warranties. This includes wall

mounts, custom cabinets and other installation methods that do not provide for direct and immediate access to the product for service purposes. Labour charges for set installation, setup, adjustment of customer controls, and installation or repair of antenna systems are not covered by these warranties. Reception problems caused by inadequate antenna systems are your responsibility.

- (5) Warranties extend only to material defects in materials or workmanship as limited above, and do not extend to:
- Service, repairs or replacement made necessary by accident, misuse, abuse, moisture, liquids, dust, dirt, neglect, accident, damage, 24/7 applications, improper installation, improper operation, improper cleaning, improper maintenance, normal wear and tear, screen burn or image retention caused by prolonged display of static images and/or phosphor aging, or any other external cause or event, act or omission outside the control of TCL, including fire, theft, acts of God, alteration, power failures, power surges or power shortages, lightning, other electrical faults, or repairs, modifications or replacements by persons other than those authorized by TCL to service the Television;
  - Replacement of missing, discarded or lost parts, the provision of retrofits, or preventive maintenance;
  - Repair of damage that is cosmetic only or does not affect the Television functionality, such as wear and tear, scratches and dents;
  - Service on Toshiba-branded accessory items (such as accessory items may be covered by their own warranty);
  - Service on third party products or service made necessary by use of incompatible third party products;
  - Service made necessary by the simultaneous use of this Television and connected equipment;
  - Modifications to the Television not approved in writing by TCL, and service made necessary by the use or installation of non-Toshiba modifications to the Television;
  - Service of a Television on which the TOSHIBA label or logo, rating label or serial number have been defaced or removed;
  - Damage to the Television caused by failure to follow the specifications, User manuals or guides as to usage and/or storage.

#### Disclaimer and Limitation of Remedy

TO THE EXTENT NOT PRECLUDED BY LAW, ALL OTHER EXPRESS AND IMPLIED WARRANTIES, CONDITIONS AND REPRESENTATIONS FOR THIS TELEVISION, INCLUDING THE IMPLIED WARRANTIES, CONDITIONS AND REPRESENTATIONS OF MERCHANTABILITY AND FITNESS FOR A PARTICULAR PURPOSE, ARE HEREBY DISCLAIMED AND EXCLUDED. IF THE APPLICABLE LAW, STATUTORY OR OTHERWISE, PRECLUDES THE EXCLUSION OF ANY IMPLIED WARRANTIES, CONDITIONS AND REPRESENTATIONS THEN SUCH IMPLIED WARRANTIES, CONDITIONS AND REPRESENTATIONS ARE OTHERWISE

LIMITED IN DURATION TO THE TERM OF THIS EXPRESS WRITTEN LIMITED WARRANTY. TO THE EXTENT NOT PRECLUDED BY LAW, STATUTORY OR OTHERWISE, THIS WRITTEN WARRANTY SUPERCEDES AND SPECIFICALLY DISCLAIMS ANY OTHER WARRANTY, CONDITION OR REPRESENTATION NOT STATED IN THIS WARRANTY, WHETHER MADE BY TCL, TOSHIBA CORPORATION, THEIR AFFILIATES, ADRs AND ASPs AND WHETHER MADE ORALLY OR IN WRITING (INCLUDING ANY STATEMENT IN ANY BROCHURE, PRESS RELEASE, ANNOUNCEMENT, ADVERTISEMENT, POINT OF SALE DISPLAY, ETC.).

YOU MUST READ AND FOLLOW ALL SET-UP AND USAGE INSTRUCTIONS IN THE APPLICABLE USER GUIDES AND/OR MANUALS. IF YOU FAIL TO DO SO, THIS TELEVISION MAY NOT FUNCTION PROPERLY AND YOU MAY SUFFER DAMAGE. THIS WARRANTY WILL NOT COVER ANY SERVICE THAT IS REQUIRED, IN PART OR IN WHOLE, AS A RESULT OF ANY FAILURE TO FOLLOW THE SET-UP AND USAGE INSTRUCTIONS. THIS WARRANTY DOES NOT APPLY AND SHALL BE VOID AND UNENFORCEABLE IF THE TELEVISION IS OPENED, SERVICED, OR REPAIRED BY PERSONS OTHER THAN THOSE AUTHORIZED BY TCL TO SERVICE OR REPAIR THE TELEVISION.

IF THE TELEVISION FAILS TO WORK AS WARRANTED ABOVE, YOUR SOLE AND EXCLUSIVE REMEDY SHALL BE REPAIR OR REPLACEMENT OF THE DEFECTIVE PART. IN NO EVENT WILL TCL, TOSHIBA CORPORATION, THEIR AFFILIATES, ADRs OR ASPs (THE "RELATED PARTIES") BE LIABLE TO YOU OR ANY THIRD PARTY FOR ANY DAMAGES, MONEY, REIMBURSEMENT, COSTS OR EXPENSES. THIS LIMITATION APPLIES TO DAMAGES, MONEY, REIMBURSEMENT, COSTS OR EXPENSES OF ANY KIND WHATSOEVER INCLUDING ANY DIRECT OR INDIRECT DAMAGES, DAMAGE TO PROPERTY OR PERSON, LOST PROFITS, LOST SAVINGS, INCONVENIENCE OR OTHER SPECIAL, INCIDENTAL, EXEMPLARY OR CONSEQUENTIAL DAMAGES, WHETHER FOR BREACH OF WARRANTY, BREACH OF CONTRACT, TORT (INCLUDING NEGLIGENCE), UNDER A STATUTE OR UNDER ANY OTHER LAW OR FORM OR ACTION, OR WHETHER ARISING OUT OF THE USE OF OR INABILITY TO USE THE TELEVISION, EVEN IF ANY OF THE RELATED PARTIES HAS BEEN ADVISED OF THE POSSIBILITY OF SUCH DAMAGES OR OF ANY CLAIM BY ANY OTHER PARTY.

No person, agent, distributor, dealer or company is authorized to change, modify or extend the terms of these warranties in any manner whatsoever.

#### Arbitration and Dispute Resolution

To the extent not precluded by law, any claim, dispute, controversy or disagreement (whether for breach of warranty, breach of contract, tort (including negligence), under a statute or under any other law or form of action) against any of the Related Parties arising out of, or otherwise relating to: (i) this warranty; (ii) the Television; (iii) any oral or written representations, statements, brochures, press releases,



advertising, announcement, point of sale display, or promotional material relating to the Television; (iv) the relationships that result from this warranty, (the foregoing claims, disputes controversies and disagreements are collectively referred to as the "Dispute"), shall be referred to and resolved by final and binding arbitration (to the exclusion of the courts). To the extent not precluded by law, you agree to waive any right that you may have to commence or participate in any representative or class proceeding against the Related Parties relating to any Dispute. If and where applicable and to the extent not precluded by law, you further agree to opt out of any such representative or class proceedings. Arbitration of any Dispute will be conducted in the forum and in the manner as agreed to between you and TCL. Failing such agreement, the arbitration will be conducted by one arbitrator pursuant to the laws and rules relating to arbitration generally in force in the jurisdiction in which you reside at the time that the Dispute arises. To the extent not precluded by law, no claim, dispute, controversy or disagreement of any other person may be joined or combined with any Dispute by you, without the prior written consent of TCL.

### Critical Applications

The Television you have purchased is not designed for any "critical applications." "Critical applications" means life support systems, medical applications, connections to implanted medical devices, commercial transportation, nuclear facilities or systems or any other applications where Television failure could lead to injury to persons or loss of life or catastrophic property damage.

IF THE CUSTOMER USES THE TELEVISION IN ANY CRITICAL APPLICATION, THE CUSTOMER AND NOT TCL, ITS AFFILIATES, ADRs OR ASPs – ASSUME SOLE AND FULL RESPONSIBILITY FOR SUCH USE. TCL RESERVES THE RIGHT TO REFUSE TO SERVICE ANY TELEVISION USED IN A CRITICAL APPLICATION. TCL, ITS AFFILIATES, ADRs AND ASPs HEREBY DISCLAIM ANY AND ALL LIABILITY, DAMAGES AND CONSEQUENCES ARISING OUT OF THE SERVICE OR REFUSAL TO SERVICE SUCH TELEVISION AND FURTHER DISCLAIM ANY AND ALL LIABILITY, CONSEQUENCES AND DAMAGES THAT MAY ARISE OR RESULT FROM THE USE OF THE TELEVISION IN ANY CRITICAL APPLICATIONS.

### General Provisions

If and to the extent that any provision of this limited warranty should generally be found to be unenforceable, the unenforceable provision shall be severed from the warranty and deemed not to form part of the warranty. The remaining provisions of this warranty shall be and remain valid and enforceable. If and to the extent that any provision of this limited warranty as it relates to any of the Related Parties is found to be invalid or unenforceable in respect of that party (the "Excluded Party"), the Excluded Party shall be deemed to be severed or excluded from the provision, and the provision shall remain valid, enforceable and applicable in respect of the other or remaining Related Parties.

To the extent permitted by law, this limited warranty shall be governed and construed in accordance with the laws of Ontario.

If there is any inconsistency between this limited warranty, on the one hand, and any statement in the packaging of the Television or in any other document enclosed with, or used in the context of the promotion or sale of, the Television, on the other hand, the provisions of this limited warranty shall prevail.

### How to Obtain Warranty Services

If, after following all of the operating instructions in this manual, checked the "Troubleshooting" section, and have visited [www.toshiba.ca/support](http://www.toshiba.ca/support) for additional information, you find that service is needed, please contact TCL Customer Support toll free at 1 800 268-3404.

For at least three (3) years from the date of distribution of the this product, Toshiba will give to anyone who contacts Toshiba Consumer Solutions at (800) 631-3811, for a charge of no more than our cost of physically performing source code distribution, a complete machine-readable copy of the complete corresponding GPL and LGPL source code for the version of the GPL and LGPL code that we distributed to you in this product.

### WMDRM End User Notice

Content owners use Windows Media digital rights management technology (WMDRM) to protect their intellectual property, including copyrights. This device uses WMDRM software to access WMDRM-protected content. If the WMDRM software fails to protect the content, content owners may ask Microsoft to revoke the software's ability to use WMDRM to play or copy protected content. Revocation does not affect unprotected content. When you download licenses for protected content, you agree that Microsoft may include a revocation list with the licenses. Content owners may require you to upgrade WMDRM to access their content. If you decline an upgrade, you will not be able to access content that requires the upgrade.

# Index

## A

|                   |    |
|-------------------|----|
| Auto Aspect ..... | 47 |
| Auto Input .....  | 30 |
| Auto Tuning ..... | 28 |
| AutoView .....    | 48 |

## B

|                                |    |
|--------------------------------|----|
| Backlight .....                | 48 |
| Backlight Adjustment Pro ..... | 50 |
| Base Color Adjustment .....    | 51 |
| Blue Screen .....              | 43 |

## C

|                           |    |
|---------------------------|----|
| Channel Browser™ .....    | 31 |
| Channel lock .....        | 37 |
| Channel Return .....      | 33 |
| Channel Tuning Mode ..... | 31 |
| ClearFrame120™ .....      | 49 |
| Closed Captions .....     | 34 |
| Color Temperature .....   | 51 |
| ColorMaster™ .....        | 51 |

## D

|                             |        |
|-----------------------------|--------|
| Daylight Saving Time .....  | 28     |
| DIGITAL AUDIO OUT .....     | 19, 53 |
| Digital CC Settings .....   | 34     |
| DNR .....                   | 50     |
| Dolby® Volume .....         | 54     |
| DVI connection .....        | 16     |
| DynaLight™ .....            | 49     |
| Dynamic Bass Boost .....    | 54     |
| Dynamic Contrast .....      | 49     |
| Dynamic Range Control ..... | 54     |

## F

|                          |    |
|--------------------------|----|
| Favorites Browser .....  | 32 |
| Film Stabilization ..... | 49 |
| FREEZE .....             | 47 |

## G

|                  |    |
|------------------|----|
| GameTimer® ..... | 38 |
|------------------|----|

## H

|                             |    |
|-----------------------------|----|
| HDMI audio mode .....       | 41 |
| HDMI connection .....       | 16 |
| HDMI settings feature ..... | 40 |

## I

|                     |    |
|---------------------|----|
| Initial Setup ..... | 25 |
| Input Lock .....    | 37 |
| INSTAPOINT™ .....   | 40 |
| IR IN .....         | 19 |
| IR OUT .....        | 18 |

## L

|                      |    |
|----------------------|----|
| Labeling .....       | 30 |
| Language .....       | 28 |
| LED Indication ..... | 78 |

|                |    |
|----------------|----|
| Location ..... | 28 |
|----------------|----|

## M

|                            |    |
|----------------------------|----|
| Manual Tuning .....        | 29 |
| Media Player .....         | 68 |
| Media Renderer Setup ..... | 66 |
| MPEG NR .....              | 50 |
| MTS .....                  | 53 |
| MUTE .....                 | 53 |

## N

|                     |    |
|---------------------|----|
| NET TV™ .....       | 61 |
| Network Setup ..... | 56 |

## O

|                |    |
|----------------|----|
| On Timer ..... | 42 |
|----------------|----|

## P

|                        |    |
|------------------------|----|
| Panel Lock .....       | 38 |
| PC audio .....         | 41 |
| PC connection .....    | 21 |
| PC settings .....      | 41 |
| Picture mode .....     | 48 |
| Picture Position ..... | 47 |
| Picture quality .....  | 48 |
| Picture size .....     | 45 |
| PIN code .....         | 35 |

## R

|                            |    |
|----------------------------|----|
| REGZA-LINK® .....          | 38 |
| Remote control             |    |
| Battery installation ..... | 23 |
| Buttons .....              | 24 |
| Device code table .....    | 88 |
| Functional key chart ..... | 82 |
| Programming .....          | 85 |
| Reset TV .....             | 44 |
| Resolution+™ .....         | 49 |
| RGB Filter .....           | 51 |
| RGB Range .....            | 40 |
| Room Lighting .....        | 50 |

## S

|                             |    |
|-----------------------------|----|
| SAP .....                   | 53 |
| Shared inputs .....         | 30 |
| Sleep Timer .....           | 42 |
| Smart Sensor .....          | 50 |
| Smart Sound Equalizer ..... | 54 |
| Software keyboard .....     | 60 |
| Static Gamma .....          | 49 |
| Stereo sound .....          | 53 |
| Support information .....   | 44 |
| SurfLock™ .....             | 33 |
| Surround .....              | 54 |

## T

|                                 |    |
|---------------------------------|----|
| Test Pattern .....              | 51 |
| TheaterLock™ .....              | 52 |
| TheaterWide® picture size ..... | 45 |

|                             |    |
|-----------------------------|----|
| Time Zone .....             | 28 |
| TV status information ..... | 44 |

## V

|                         |    |
|-------------------------|----|
| V-Chip blocking .....   | 35 |
| Voice Enhancement ..... | 54 |

## W

|                     |    |
|---------------------|----|
| White Balance ..... | 51 |
|---------------------|----|

---

## ***Note***

## **TOSHIBA AMERICA CONSUMER PRODUCTS, L.L.C.**

Corporate Headquarters: 82 TOTOWA ROAD, WAYNE, NJ 07470, U.S.A.  
NATIONAL SERVICE DIVISION: 1420-B TOSHIBA DRIVE, LEBANON, TN 37087, U.S.A.

## **TOSHIBA OF CANADA LTD.**

HEAD OFFICE: 191 McNABB STREET, MARKHAM, ONTARIO, L3R 8H2, CANADA – TEL: (905) 470-5400  
SERVICE CENTERS:  
TORONTO: 191 McNABB STREET, MARKHAM, ONTARIO L3R 8H2, CANADA – TEL: (905) 470- 5400

MANUFACTURED BY

## **TOSHIBA ELECTROMEX, S.A. DE C.V.**

ColorStream, GameTimer and TheaterWide are registered trademarks of Toshiba America Consumer Products, L.L.C.  
AutoView, Channel Browser, ClearFrame, DynaLight, ColorMaster, NET TV, SurfLock and TheaterLock are trademarks of Toshiba America Consumer Products, L.L.C.  
REGZA and REGZA-LINK are registered trademarks of Toshiba Corporation.  
Resolution+ is a trademark of Toshiba Corporation.