



Count on it.

Operator's Manual

**Z593-D Z Master[®] with 52in
or 60in TURBO FORCE[®] Side
Discharge Mower**

Model No. 74264—Serial No. 250000001 and Up

Model No. 74265—Serial No. 250000001 and Up

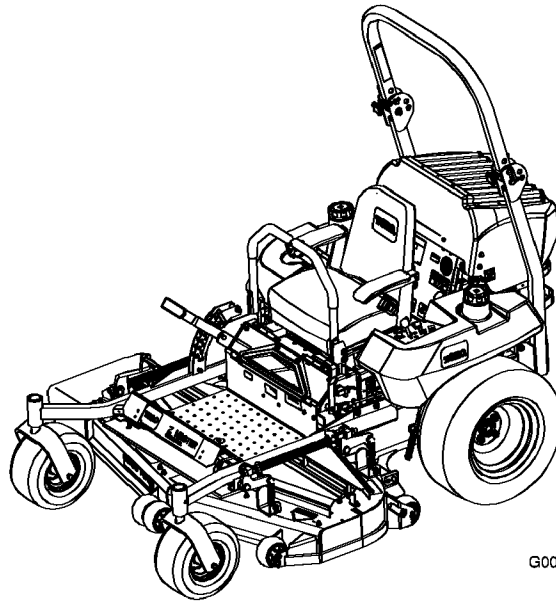

G001093

Warning

CALIFORNIA Proposition 65 Warning

The engine exhaust from this product contains chemicals known to the State of California to cause cancer, birth defects, or other reproductive harm.

Important: This engine is not equipped with a spark arrester muffler. It is a violation of California Public Resource Code Section 4442 to use or operate the engine on any forest-covered, brush-covered, or grass-covered land. Other states or federal areas may have similar laws.

This spark ignition system complies with Canadian ICES-002

The enclosed Engine Owner's Manual is supplied for information regarding the US Environmental Protection Agency (EPA) and the California Emission Control Regulation of emission systems, maintenance, and warranty. Replacements may be ordered through the engine manufacturer.

Introduction

Read this information carefully to learn how to operate and maintain your product properly and to avoid injury and product damage. You are responsible for operating the product properly and safely.

You may contact Toro directly at www.Toro.com for product and accessory information, help finding a dealer, or to register your product.

Whenever you need service, genuine Toro parts, or additional information, contact an Authorized Service Dealer or Toro Customer Service and have the model and serial numbers of your product ready. Figure 1 identifies the location of the model and serial numbers on the product. Write the numbers in the space provided.

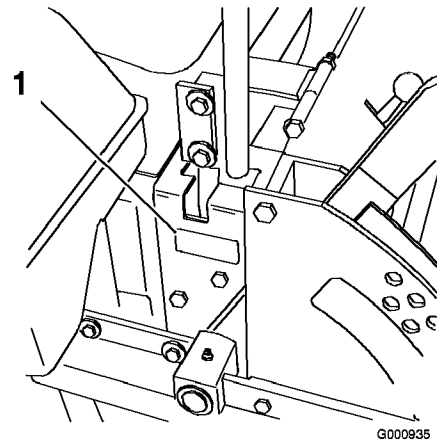

Figure 1

1. Model and serial number location

Model No. _____
Serial No. _____

This manual identifies potential hazards and has safety messages identified by the safety alert symbol (Figure 2), which signals a hazard that may cause serious injury or death if you do not follow the recommended precautions.



Figure 2

1. Safety alert symbol

This manual uses 2 other words to highlight information. **Important** calls attention to special mechanical information and **Note** emphasizes general information worthy of special attention.

Contents

Introduction	2
Safety	4
Safe Operating Practices	4
Slope Chart	7
Safety and Instructional Decals	8
Product Overview	14
Controls	14
Operation.....	15
Adding Fuel	15
Checking the Engine Oil Level	16

Switching the Fuel Tanks	16	Adjusting the Parking Brake	44
Using the Rollover Protection		Belt Maintenance.....	44
System (ROPS).....	16	Inspecting the Belts	44
Think Safety First	18	Replacing the Mower Belt	44
Operating the Parking Brake	18	Replacing the PTO Drive Belt	45
Starting and Stopping the		Replacing the Pump Drive	
Engine	19	Belt	46
Operating the Power Take Off		Replacing and Tensioning the	
(PTO)	21	Alternator Belt.....	46
The Safety Interlock System.....	21	Controls System Maintenance.....	48
Driving Forward or Backward.....	22	Adjusting the Control Handle	
Stopping the Machine.....	22	Neutral Position	48
Adjusting the Height-of-Cut	23	Hydraulic System Maintenance	49
Adjusting the Anti-Scalp		Servicing the Hydraulic	
Rollers.....	23	System.....	49
Adjusting the Flow Baffle.....	24	Setting the Hydraulic Pump	
Positioning the Flow Baffle	24	Neutral Position	51
Positioning the Seat	25	Mower Deck Maintenance	53
Unlatching the Seat.....	26	Leveling the Mower at Three	
Pushing the Machine by Hand.....	26	Positions	53
Using the Side Discharge	26	Servicing the Cutting Blades.....	55
Transporting Machines	27	Replacing the Grass Deflector.....	58
Loading Machines	27	Cleaning.....	58
Operating Tips	28	Cleaning Under the Mower	58
Maintenance.....	30	Waste Disposal.....	58
Recommended Maintenance		Storage.....	59
Schedule(s)	30	Cleaning and Storage	59
Lubrication.....	31	Troubleshooting.....	60
Greasing and Lubrication.....	31	Schematics	63
Greasing the Mower Deck and Belt			
Idlers.....	32		
Engine Maintenance.....	32		
Servicing the Air Cleaner	32		
Servicing the Engine Oil	33		
Fuel System Maintenance	36		
Servicing the Fuel Filters.....	36		
Servicing the Fuel Tank.....	37		
Electrical System Maintenance.....	37		
Servicing the Battery.....	37		
Servicing the Fuses	39		
Drive System Maintenance.....	40		
Adjusting the Tracking.....	40		
Checking the Tire Pressure.....	41		
Checking the Wheel Hub Slotted			
Nut	41		
Adjusting the Caster Pivot			
Bearing.....	42		
Servicing the Gear Box	42		
Cooling System Maintenance	43		
Servicing the Cooling System	43		
Brake Maintenance	44		

Safety

Improper use or maintenance by the operator or owner can result in injury. To reduce the potential for injury, comply with these safety instructions and always pay attention to the safety alert symbol, which means **CAUTION, WARNING, or DANGER**-“personal safety instruction.” Failure to comply with the instruction may result in personal injury or death.

This product is capable of amputating hands and feet and throwing objects. Always follow all safety instructions to avoid serious injury or death.

This product is designed for cutting and recycling grass or, when equipped with a grass bagger, for catching cut grass. Any use for purposes other than these could prove dangerous to user and bystanders.

Safe Operating Practices

The following instructions are from ANSI standard B71.4-2004.

Training

- Read the Operator’s Manual and other training material. If the operator(s) or mechanic(s) can not read English it is the owner’s responsibility to explain this material to them.
- Become familiar with the safe operation of the equipment, operator controls, and safety signs.
- All operators and mechanics should be trained. The owner is responsible for training the users.
- Never let children or untrained people operate or service the equipment. Local regulations may restrict the age of the operator.
- The owner/user can prevent and is responsible for accidents or injuries occurring to himself or herself, other people or property.

Preparation

- Evaluate the terrain to determine what accessories and attachments are needed to properly and safely perform the job. Only use accessories and attachments approved by the manufacturer.
- Wear appropriate clothing including hard hat, safety glasses and hearing protection. Long

hair, loose clothing or jewelry may get tangled in moving parts.

- Inspect the area where the equipment is to be used and remove all objects such as rocks, toys and wire which can be thrown by the machine.
- Use extra care when handling diesel and other fuels. They are flammable and vapors are explosive.
 - Use only an approved container
 - Never refuel or drain the machine indoors.
 - Never remove gas cap or add fuel with engine running. Allow engine to cool before refueling. Do not smoke.
- Check that operator’s presence controls, safety switches and shields are attached and functioning properly. Do not operate unless they are functioning properly.

Operation

- Never run an engine in an enclosed area.
- Only operate in good light, keeping away from holes and hidden hazards.
- Be sure all drives are in neutral and parking brake is engaged before starting engine. Start the engine only from the operator’s position. Use seat belts.
- Never raise mower with the blades running.
- Never operate without the PTO shield, or other guards securely in place. Be sure all interlocks are attached, adjusted properly, and functioning properly.
- Never operate with the discharge deflector raised, removed or altered, unless using a grass catcher.
- Do not change the engine governor setting or overspeed the engine.
- Stop on level ground, lower implements, disengage drives, engage parking brake, shut off engine before leaving the operator’s position for any reason including emptying the catchers or unclogging the chute.
- Stop equipment and inspect blades after striking objects or if an abnormal vibration occurs. Make necessary repairs before resuming operations.

- Keep hands and feet away from the cutting units.
- Never carry passengers and keep pets and bystanders away.
- Be alert, slow down and use caution when making turns. Look behind and to the side before changing directions.
- Slow down and use caution when crossing roads and sidewalks. Stop blades if not mowing.
- Be aware of the mower discharge direction and do not point it at anyone.
- Do not operate the mower under the influence of alcohol or drugs.
- Use extreme care when loading or unloading the machine into a trailer or truck.
- Use care when approaching blind corners, shrubs, trees, or other objects that may obscure vision.

Slope Operation

- Do not mow slopes greater than 15 degrees.
- Do not mow near drop-offs, ditches, steep banks or water. Wheels dropping over edges can cause rollovers, which may result in serious injury, death or drowning.
- Do not mow slopes when grass is wet. Slippery conditions reduce traction and could cause sliding and loss of control.
- Do not make sudden turns or rapid speed changes.
- Use a walk behind mower and/or a hand trimmer near drop-offs, ditches, steep banks or water.
- Reduce speed and use extreme caution on slopes.
- Remove or mark obstacles such as rocks, tree limbs, etc. from the mowing area. Tall grass can hide obstacles.
- Watch for ditches, holes, rocks, dips, and rises that change the operating angle, as rough terrain could overturn the machine.
- Avoid sudden starts when mowing uphill because the mower may tip backwards.
- Be aware that loss of traction may occur going downhill. Weight transfer to the front wheels may cause drive wheels to slip and cause loss of braking and steering.

- Always avoid sudden starting or stopping on a slope. If tires lose traction, disengage the blades and proceed slowly off the slope.
- Follow the manufacturer's recommendations for wheel weights or counterweights to improve stability.
- Use extreme care with grass catchers or other attachments. These can change the stability of the machine and cause loss of control.

Using the Rollover Protection System (ROPS)

- Keep the roll bar in the raised and locked position and use the seat belt when operating the machine.
- Be certain that the seat belt can be released quickly in the event of an emergency.
- Be aware there is no rollover protection when the roll bar is down.
- Check the area to be mowed and never fold the ROPS in areas where there are slopes, drop offs or water.
- Lower the rollbar only when absolutely necessary. Do not wear the seat belt with the roll bar folded down.
- Check carefully for overhead clearances (i.e. branches, doorways, electrical wires) before driving under any objects and do not contact them.

Maintenance and storage

- Disengage drives, lower implement, set parking brake, stop engine and remove key or disconnect spark plug wire. Wait for all movement to stop before adjusting, cleaning or repairing.
- Clean grass and debris from cutting units, drives, mufflers, and engine to help prevent fires. Clean up oil or fuel spillage.
- Let engine cool before storing and do not store near flame.
- Shut off fuel while storing or transporting. Do not store fuel near flames or drain indoors.
- Park machine on level ground. Never allow untrained personnel to service machine.
- Use jack stands to support components when required.

- Carefully release pressure from components with stored energy.
- Disconnect battery or remove spark plug wire before making any repairs. Disconnect the negative terminal first and the positive last. Reconnect positive first and negative last.
- Use care when checking blades. Wrap the blade(s) or wear gloves, and use caution when servicing them. Only replace blades. Never straighten or weld them.
- Keep hands and feet away from moving parts. If possible, do not make adjustments with the engine running.
- Charge batteries in an open well ventilated area, away from spark and flames. Unplug charger before connecting or disconnecting from battery. Wear protective clothing and use insulated tools.
- Keep all parts in good working condition and all hardware tightened. Replace all worn or damaged decals.
- Use only Toro approved attachments. Warranty may be voided if used with unapproved attachments.

Slope Chart

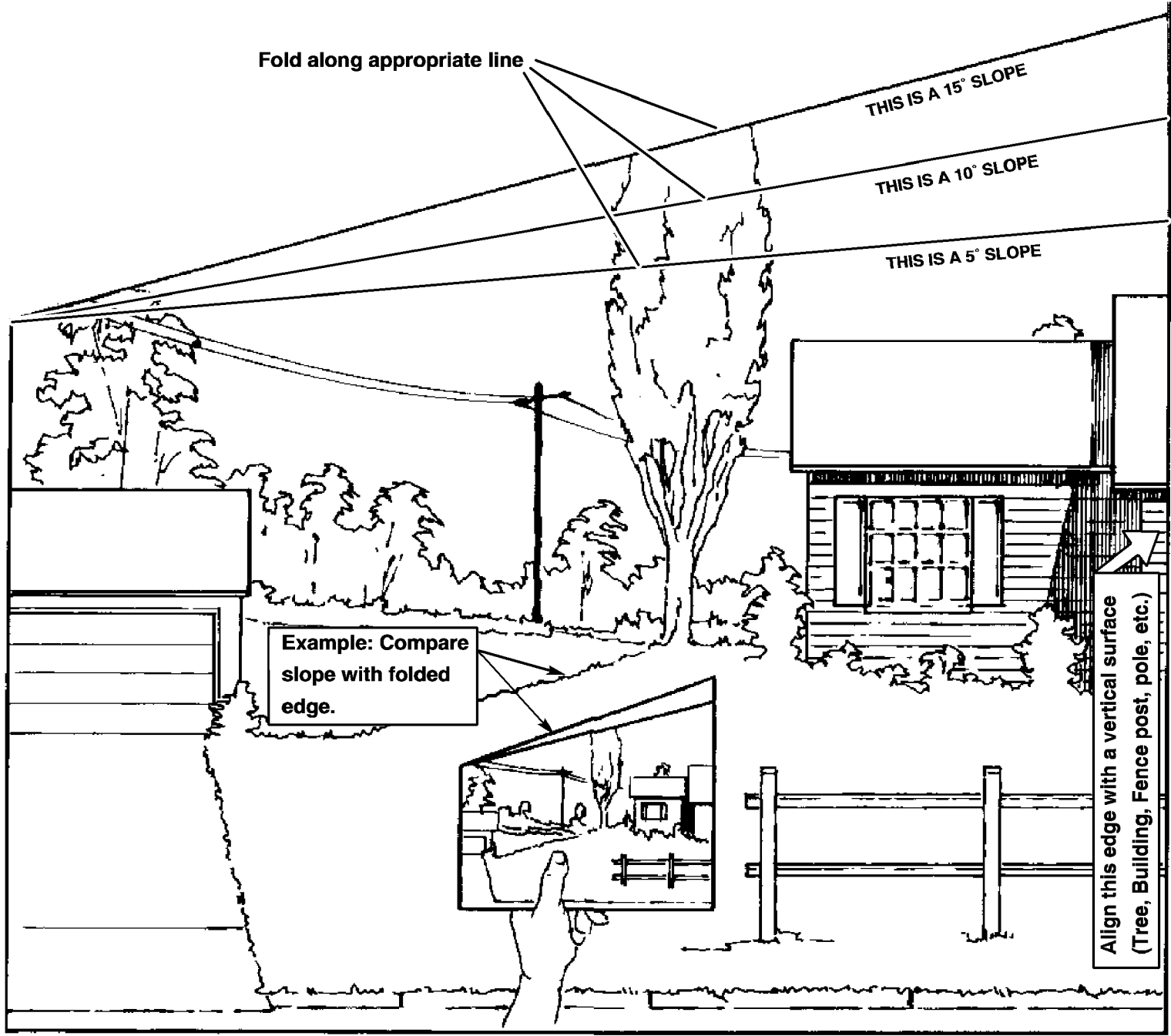

Safety and Instructional Decals



Safety decals and instructions are easily visible to the operator and are located near any area of potential danger. Replace any decal that is damaged or lost.



1-523552



54-9220



1-643253



1
58-6520

1. Grease



43-8480



66-1340



65-2690

⚠ CAUTION
BLADE RETAINING BOLTS MUST BE TORQUED TO 85-110 ft-lbs. CHECK BLADE BOLT TORQUE AFTER STRIKING ANY SOLID OBJECT.
68-8340

68-8340

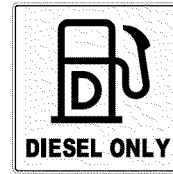

103-1636



98-4387

1. Warning—wear hearing protection.

⚠ DANGER
COVER IS MISSING. DO NOT OPERATE THIS UNIT WHEN COVER IS NOT IN PLACE.
98-5954

98-5954

ANTI-SCALP ROLLER ADJUSTMENT
FOR MAXIMUM DECK FLOTATION, PLACE ROLLERS IN POSITIONS SHOWN.
TURN ENGINE OFF BEFORE MAKING ROLLER ADJUSTMENTS.

- ————— 1.5"/38mm
- ————— 2.0"/51mm
- ————— 2.5"/63mm
- ————— 3.0"/76mm

105-7798

105-7798

⚠ DANGER

- Pick up objects that could be thrown by the blades.
- Never mow when bystanders are in the area.
- Never carry passengers.
- Look behind and to the side before changing directions.
- Stop the engine and remove key before adjusting, servicing or cleaning machine and attachments.



Before leaving the operator's position:

- Stop the engine and disengage the blade.
- Move the levers out to the neutral lock position.
- Set the parking brake.
- Avoid blades unless engine and blades are stopped.



106-7492

106-7492

For replacement manual, send model & serial number to: The Toro Co., 8111 Lyndale Ave. S., Bloomington, MN 55420.

IMPORTANT: Before starting engine clean grass from pump drive belt compartment. Check more often in dry conditions.

⚠ WARNING

To avoid serious injury or death:

- Read and understand the operator's manual before using this machine.
- Do not operate unless trained to safely use this machine.
- Do not operate under the influence of alcohol or drugs.
- Do not operate without shields, guards, and safety devices in place and working.
- Check the function of all safety interlocks daily.
- Do not defeat interlocks.
- Hearing protection is recommended.

106-9989

**GREASE
GRASA** →

107-1613

107-1613

⇐ **DISENGAGE**

↑

↓

⇐ **ENGAGE**

(P) BRAKE

107-1857

107-1857

A-

- Short, light grass
- Dry conditions
- Maximum dispersion

• Césped corto y ligero

• Condiciones secas

• Maxima dispersion

B-

- Bagging setting

• Posicion para usar con bolsa

C-

- Tall, dense grass
- Wet conditions
- Maximum ground speed

• Césped alto y denso

• Condiciones mojadas

• Maxima velocidad

107-1622

107-1622

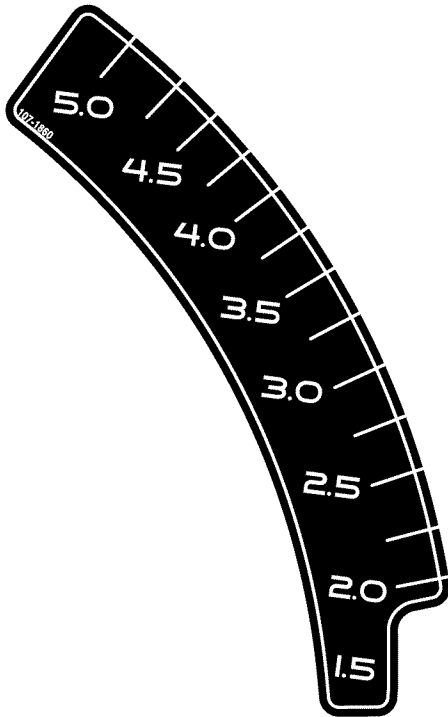

107-1860

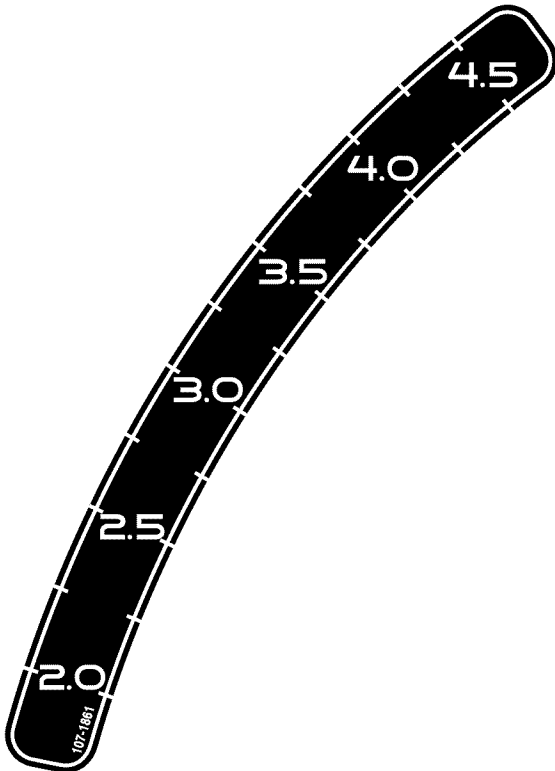

107-1861



107-1864



107-2102

⚠ WARNING

- Operating on wet grass or steep slopes can cause sliding and loss of control.
- Wheels dropping over edges can cause rollovers, which may result in serious injury, death or drowning.
- To avoid loss of control and possibility of rollover:
 - Do NOT operate near drop-offs or near water.
 - Do NOT operate on slopes greater than 15°.
 - Reduce speed and use extreme caution on slopes.
 - Avoid sudden turns or rapid speed changes.
- There is no rollover protection when the roll bar is down.
- Always keep roll bar in the raised and locked position and use seat belt.
- Read and follow rollover protection instructions and warning.

107-2112

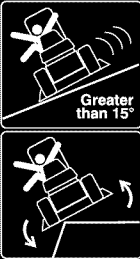

107-2112

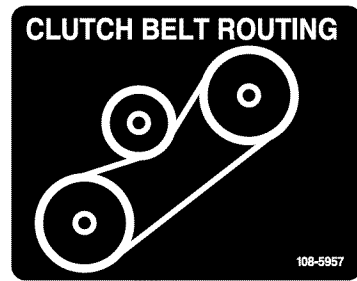

108-5957

TORO Landscape Contractor Equipment

THIS COOLING SYSTEM PROTECTED BY:



Shell DEX-COOL®* Extended Life Antifreeze/Coolant

- Top off with Shell DEX-COOL®* Extended Life Antifreeze/Coolant.
- Suggested change interval is at 4 years or 4,000 hours of service.
- Do not mix with conventional coolants.
- Shell DEX-COOL®* Extended Life Antifreeze/Coolant is available at your local auto parts store.

107-2449

DEX-COOL is a registered trademark of General Motors Corp. 104-2449

107-2449

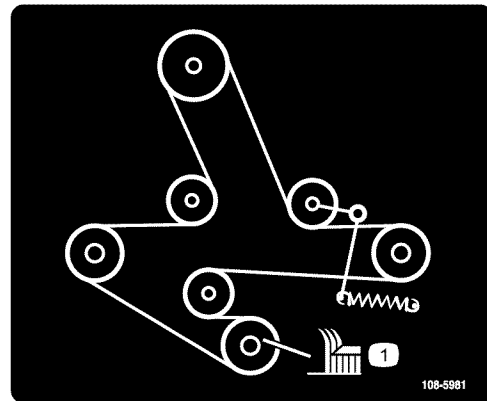

108-5981



110-0305

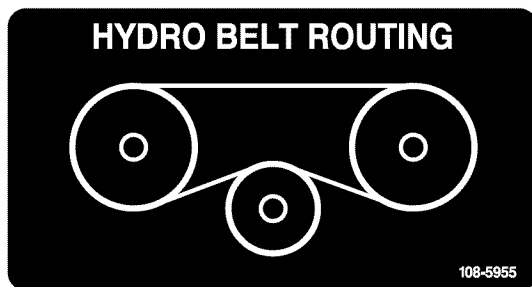

108-5955

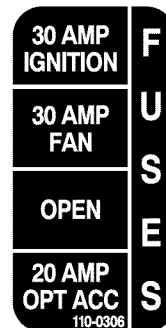

110-0306

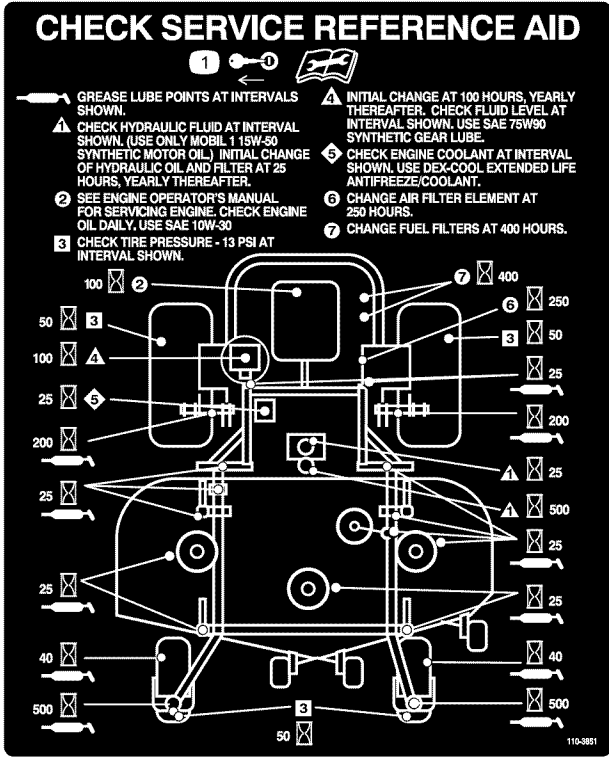

110-3851

1. Remove the ignition key and read the instructions before servicing or performing maintenance.

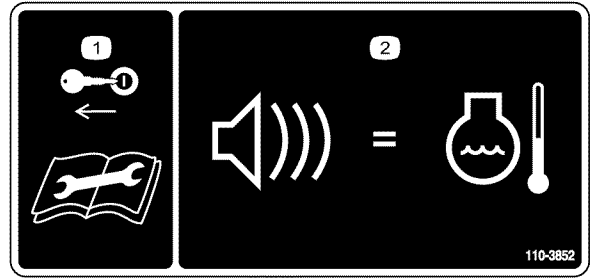

110-3852

1. Remove the ignition key and read the instructions before servicing or performing maintenance.
2. Continuous tone signals the user that engine is overheating.

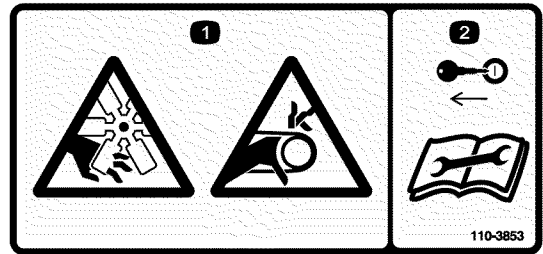

110-3853

1. Cutting/dismemberment hazard, fan and entanglement hazard, belt.
2. Remove the ignition key and read the instructions before servicing or performing maintenance.



Manufacturer's Mark

1. Indicates the blade is identified as a part from the original machine manufacturer.

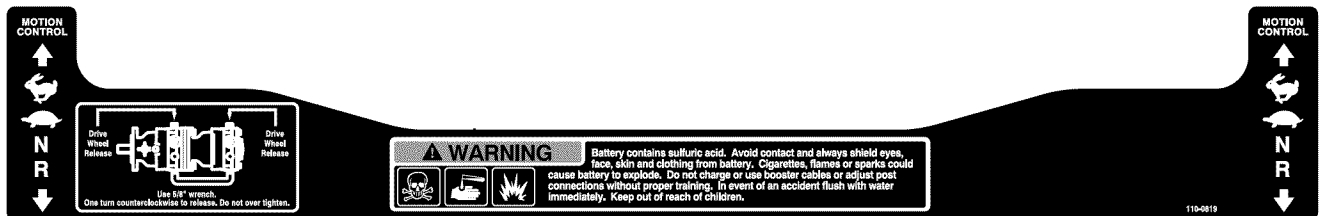

110-0819

Product Overview

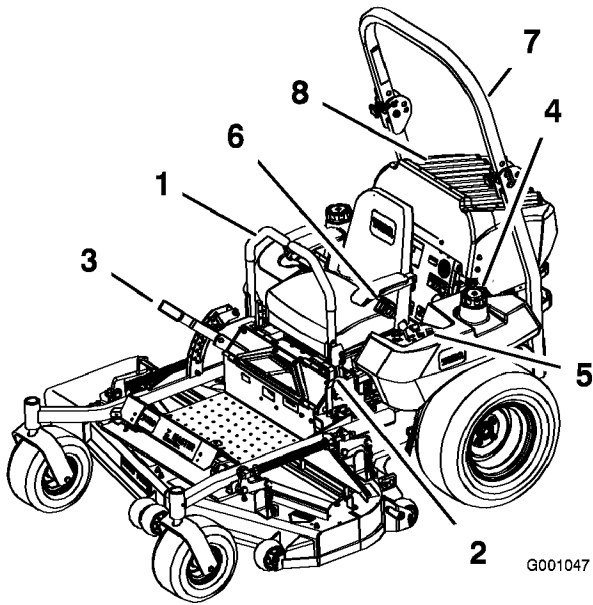

Figure 3

- | | |
|--------------------------|------------------|
| 1. Motion control lever | 5. Controls |
| 2. Parking brake lever | 6. Seat belt |
| 3. Height-of-cut lever | 7. Roll bar |
| 4. Fuel cap (both sides) | 8. Engine screen |

Controls

Become familiar with all the controls before you start the engine and operate the machine (Figure 3 and Figure 4).

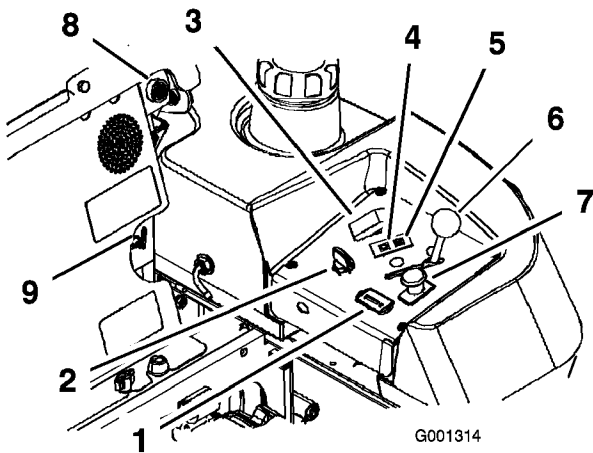

Figure 4

- | | |
|-----------------------------|------------------------|
| 1. Hour meter | 6. Throttle control |
| 2. Ignition switch | 7. PTO Switch |
| 3. Glow plug switch | 8. Audible alarm |
| 4. Glow plug light | 9. Fuel selector valve |
| 5. Engine Temperature light | |

Hour Meter

The hour meter records the number of hours the engine has operated. It operates when the engine is running. Use these times for scheduling regular maintenance (Figure 4).

Glow Plug Light

The glow plug indicator light turns on when the glow plug button is engaged (Figure 4).

Glow Plug Switch

This switch activates the glow plugs and is indicated by the glow plug light. Hold down the glow plug switch for 10 seconds prior to starting.

Temperature Light

The temperature light comes on when the engine is over heating (Figure 4).

Audible Alarm

This machine has an audible alarm that alerts the user to turn off the engine or engine damage can occur from over heating. Refer to Servicing the Cooling System in Cooling System Maintenance, page 43.

Fuel Selector Valve

The fuel selector valve is located behind the seat.

Close the fuel selector valve when transporting or storing mower.

Move the selector valve to the left-hand (LH) or right-hand (RH) position for operation.

Operation

Note: Determine the left and right sides of the machine from the normal operating position.

Adding Fuel

The engine runs on clean, fresh diesel fuel with a minimum octane rating of 40. Purchase fuel in quantities that can be used within 30 days to ensure fuel freshness.

Use summer grade diesel fuel (No. 2-D) at temperatures above 20° F (-7° C) and winter grade diesel fuel (No. 1-D or No. 1-D/2-D blend) below 20° F (-7° C). Use of winter grade diesel fuel at lower temperatures provides lower flash point and pour point characteristics, therefore easing startability and lessening chances of chemical separation of the fuel due to lower temperatures (wax appearance, which may plug filters).

Use of summer grade diesel fuel above 20° F (-7° C) will contribute toward longer life of the pump components.

Important: Do not use kerosene or gasoline instead of diesel fuel. Failure to observe this caution will damage the engine.



Fuel is harmful or fatal if swallowed. Long-term exposure to vapors can cause serious injury and illness.

- Avoid prolonged breathing of vapors.
- Keep face away from nozzle and gas tank or conditioner opening.
- Keep gas away from eyes and skin.



In certain conditions, fuel is extremely flammable and highly explosive. A fire or explosion from fuel can burn you and others and can damage property.

- Fill the fuel tank outdoors, in an open area, when the engine is cold. Wipe up any fuel that spills.
- Never fill the fuel tank inside an enclosed trailer.
- Do not fill the fuel tank completely full. Add fuel to the fuel tank until the level is 1/4 to 1/2 inch (6 to 13 mm) below the bottom of the filler neck. This empty space in the tank allows fuel to expand.
- Never smoke when handling fuel, and stay away from an open flame or where fuel fumes may be ignited by a spark.
- Store fuel in an approved container and keep it out of the reach of children. Never buy more than a 30-day supply of fuel.
- Always place fuel containers on the ground away from your vehicle before filling.
- Do not fill fuel containers inside a vehicle or on a truck or trailer bed because interior carpets or plastic truck bed liners may insulate the container and slow the loss of any static charge.
- When practical, remove gas-powered equipment from the truck or trailer and refuel the equipment with its wheels on the ground.
- If this is not possible, then refuel such equipment on a truck or trailer from a portable container, rather than from a fuel dispenser nozzle.
- If a fuel dispenser nozzle must be used, keep the nozzle in contact with the rim of the fuel tank or container opening at all times until fueling is complete.

Filling the Fuel Tank

1. Shut the engine off and set the parking brake.

2. Clean around each fuel tank cap and remove the cap. Add fuel to both fuel tanks, until the level is 1/4 to 1/2 inch (6 to 13 mm) below the bottom of the filler neck. This space in the tank allows the fuel to expand. Do not fill the fuel tanks completely full.
3. Install fuel tank caps securely. Wipe up any fuel that may have spilled.
4. If possible, fill the fuel tank after each use. This will minimize possible buildup of condensation inside the fuel tank.

Checking the Engine Oil Level

Before you start the engine and use the machine, check the oil level in the engine crankcase; refer to Checking Oil Level in Engine Maintenance, page 32

Switching the Fuel Tanks

Important: Do not run the machine out of fuel.

The fuel selector valve is located behind the left side of the seat.

The unit has two fuel tanks. One tank is on the left side and one on the right side. Each tank connects to the fuel selector valve. From there a common fuel line leads to the engine (Figure 5).

To use the left side fuel tank rotate the fuel selector valve to the LH, lefthand location. To use the right side fuel tank rotate the fuel selector valve to the RH, righthand location (Figure 5)

Close the fuel selector valve before transporting or storing machine.

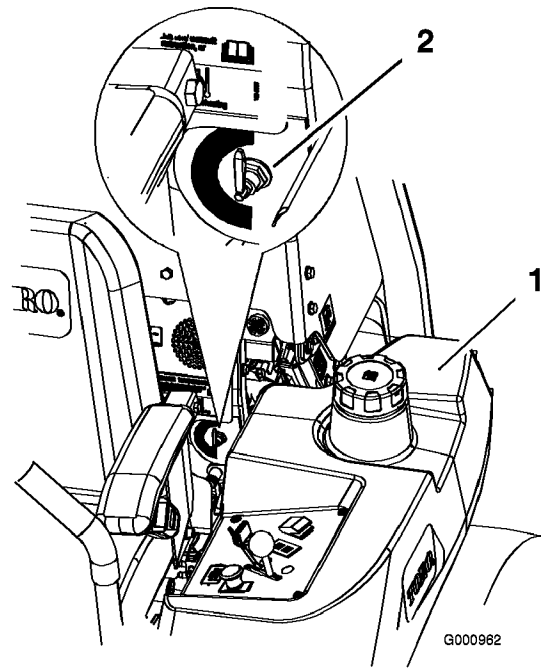

Figure 5

1. Left side fuel tank
2. Fuel selector valve

Using the Rollover Protection System (ROPS)



To avoid injury or death from rollover: keep the roll bar in the raised locked position and use the seat belt.

Ensure that the rear part of the seat is secured with the seat latch.



There is no rollover protection when the roll bar is in the down position.

- Lower the roll bar only when absolutely necessary.
- Do not wear the seat belt when the roll bar is in the down position.
- Drive slowly and carefully.
- Raise the roll bar as soon as clearance permits.
- Check carefully for overhead clearances (i.e. branches, doorways, electrical wires) before driving under any objects and do not contact them.

Important: Lower the roll bar only when absolutely necessary.

1. To lower the roll bar, loosen the front knobs (Figure 8).
2. Remove the hairpin cotter pins and remove the two pins (Figure 7).
3. Lower the the roll bar to the down position. There are two down positions. See Figure 6 for the positions.
4. Install the two pins and secure them with the hairpin cotter pins (Figure 7).

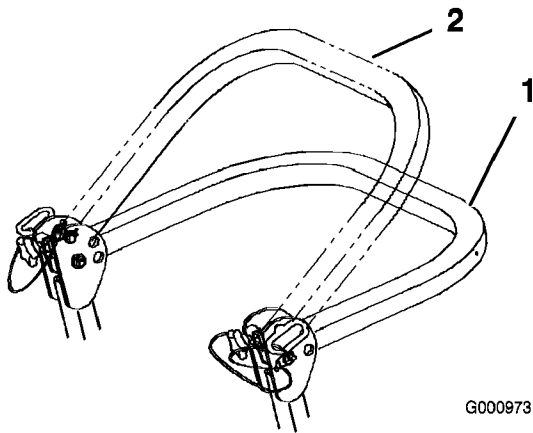

Figure 6

1. Full down position
2. Down position with bagger installed

Important: Ensure that the rear part of the seat is secured with the seat latch.

5. To raise the roll bar, remove the hairpin cotter pins and remove the two pins (Figure 7).
6. Raise the roll bar to the upright position and install the two pins and secure them with the hairpin cotter pins (Figure 7).

Important: Always use the seat belt with the roll bar in the raised position.

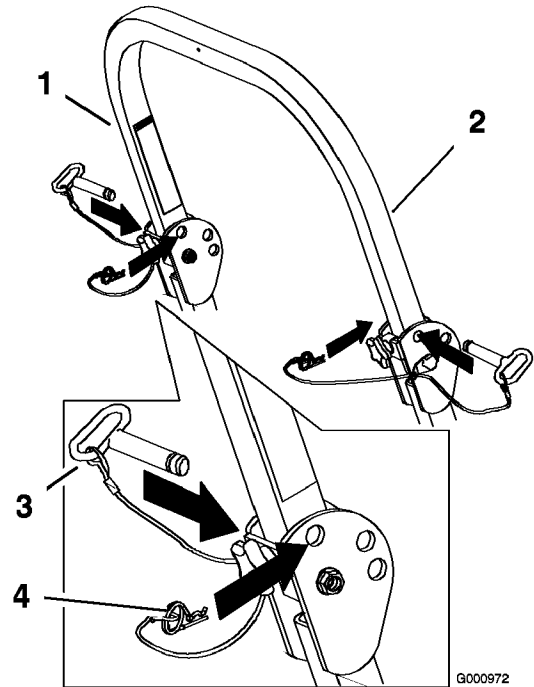

Figure 7

1. Roll bar
2. Raised position
3. Pin
4. Hairpin cotter pin

Important: Tighten the front knobs against the center roll bar ends (Figure 8).

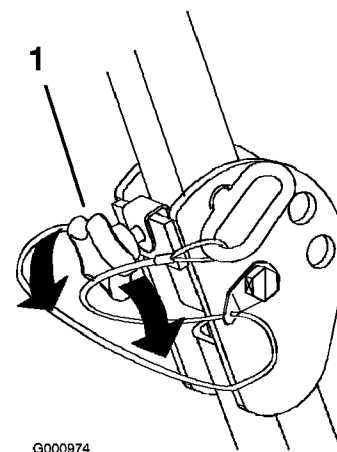

Figure 8

1. Front handle

Think Safety First

Please read all safety instructions and symbols in the safety section. Knowing this information could help you or bystanders avoid injury.



Operating on wet grass or steep slopes can cause sliding and loss of control.

Wheels dropping over edges can cause rollovers, which may result in serious injury, death or drowning.

There is no rollover protection when the roll bar is down.

Always keep the roll bar in the raised and locked position and use the seat belt.

Read and follow the rollover protection instructions and warnings.

To avoid loss of control and possibility of rollover:

- Do not operate near drop-offs or near water.
- Do not operate on slopes greater than 15 degrees.
- Reduce speed and use extreme caution on slopes.
- Avoid sudden turns or rapid speed changes.

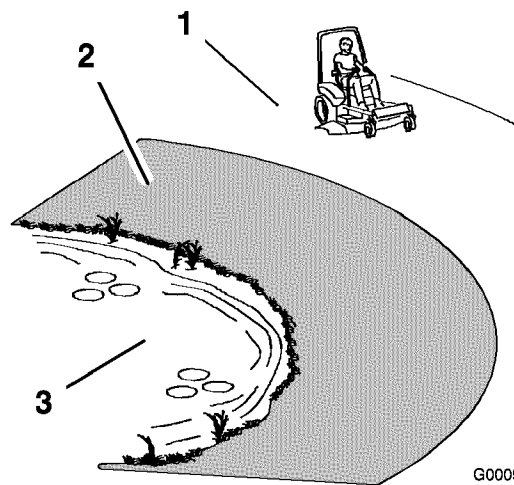

Figure 9

1. Safe Zone-use the Z Master here on slopes less than 15 degrees or flat areas.
2. Use walk behind mower and/or hand trimmer near drop-offs and water.
3. Water



This machine produces sound levels in excess of 85 dBA at the operators ear and can cause hearing loss through extended periods of exposure.

Wear hearing protection when operating this machine.

The use of protective equipment for eyes, ears, feet and head is recommended.

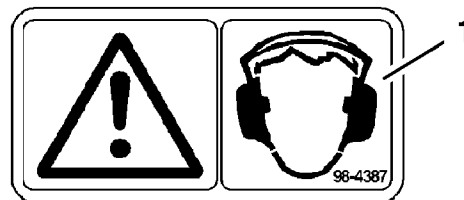

Figure 10

1. Warning— wear hearing protection

Operating the Parking Brake

Always set the parking brake when you stop the machine or leave it unattended.

Setting the Parking Brake

1. Move the motion control levers (Figure 16) out to the neutral lock position.
2. Pull up and back on the parking brake lever to set the parking brake (Figure 11). The parking brake lever should stay firmly in the engaged position.

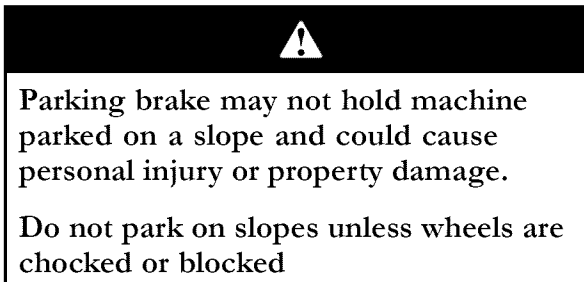

Releasing the Parking Brake

Push forward and down on the parking brake lever to release the parking brake (Figure 11). The parking brake is disengaged and the lever will rest against the brake stop.

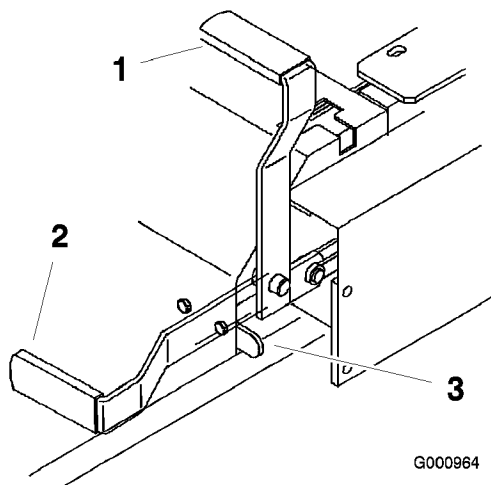

Figure 11

1. Parking brake-ON
2. Parking brake-OFF
3. Brake Stop

Starting and Stopping the Engine

Starting the Engine in Normal Weather

1. Raise the ROPS up and lock into place, sit on the seat and fasten the seat belt.
2. Move the motion controls to the neutral locked position.

3. Set the parking brake; refer to Setting the Parking Brake.
4. Move the PTO (power take off) switch to the off position (Figure 12).
5. Move the throttle lever to the middle position (Figure 14).
6. Turn the ignition key clockwise to the run position (Figure 13).
7. Push the glow plug switch for 10 seconds. The light will turn on.
8. Release the switch after 10 seconds. The light will turn off.

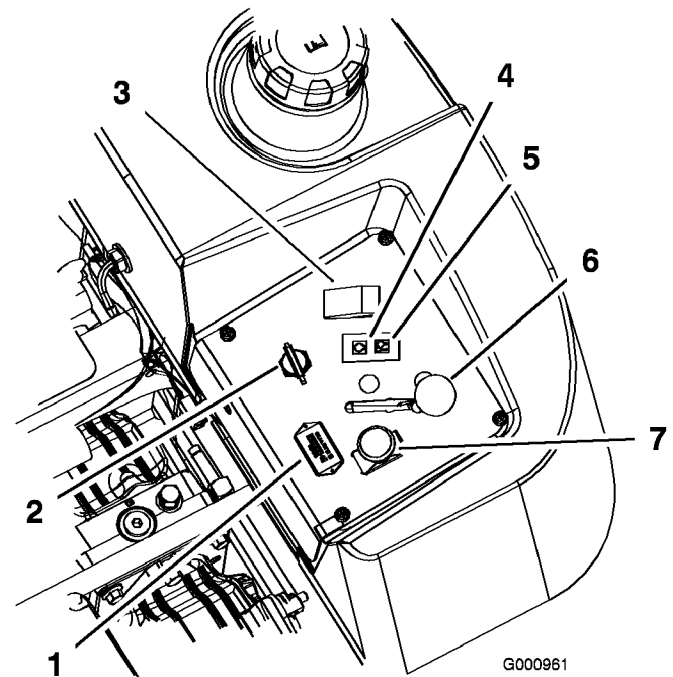

Figure 12

1. Hour meter
2. Ignition switch
3. Glow plug switch
4. Glow plug light
5. Engine Temperature light
6. Throttle control
7. PTO Switch

9. Turn the key to the start position and the glow plug indicator light will come back on. When the engine starts, release the key (Figure 13).

Important: Use starting cycles of no more than 30 seconds per minute to avoid overheating the starter motor.

10. If the engine does not start immediately, move the throttle control to fast and turn the key to the start position.

Note: Additional starting cycles may be required when starting the engine for the first time after the fuel system has been completely without fuel.

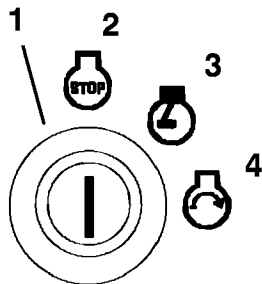

G001063

Figure 13

- | | |
|--------------------|----------|
| 1. Ignition switch | 3. Run |
| 2. Off | 4. Start |

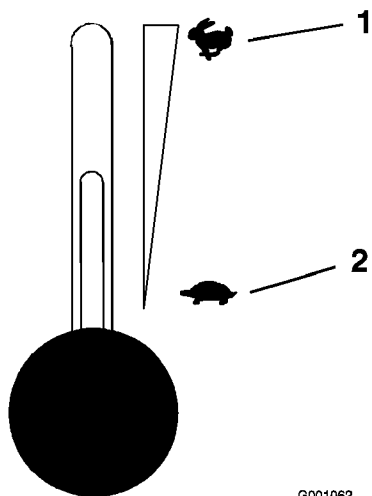

G001062

Figure 14

- | | |
|------------------|------------------|
| 1. Throttle—fast | 2. Throttle—slow |
|------------------|------------------|

Starting the Engine in Cold Weather (Below 23°F or -5°C)

Use the correct engine oil for the starting temperature. Refer to Servicing the Engine Oil in Engine Maintenance, page 32.

1. Start the engine with the throttle in the **Fast** position.
2. Turn the ignition key clockwise to the run position (Figure 13).
3. Push the glow plug switch for 10 to 15 seconds. The light will turn on.

4. Release the switch after 10 to 15 seconds. The light will turn off.
5. Turn the key to the start position and the glow plug indicator light will come back on. When the engine starts, release the key.

Important: Use starting cycles of no more than 30 seconds per minute to avoid overheating the starter motor.

Note: Do not use fuel left over from the summer. Use only fresh winter grade diesel fuel.

Stopping the Engine

1. Disengage the PTO, move the motion control levers to the neutral locked position and set the parking brake (Figure 15).
2. Move the throttle lever midway between the slow and fast positions (Figure 14).
3. Let the engine idle for 60 seconds.
4. Turn the ignition key to the off position (Figure 13). Wait for all moving parts to stop before leaving the operating position.
5. Remove the key to prevent possibility of someone accidentally starting the machine before transporting or storing machine.
6. Close the fuel selector valve before transporting or storing the machine.

Important: Make sure that the fuel selector valve is closed before transporting or storing the machine, as fuel leakage may occur. Set the parking brake before transporting.

Important: Make sure to remove the key as the fuel pump may run and cause the battery to lose charge.



Children or bystanders may be injured if they move or attempt to operate the tractor while it is unattended.

Always remove the ignition key and set the parking brake when leaving the machine unattended, even if just for a few minutes.

Operating the Power Take Off (PTO)

The power take off (PTO) switch starts and stops the mower blades and any powered attachments.

Engaging the PTO

1. If the engine is cold, allow the engine to warm up 5 to 10 minutes before engaging the PTO.
2. While seated in the seat, release the pressure on the traction control levers and place in neutral.
3. Place the throttle in the fast position.

Note: Engaging the PTO with the throttle at the half or less position will cause excessive wear to the drive belts.

4. Pull out on the power take off (PTO) switch to engage it (Figure 15).

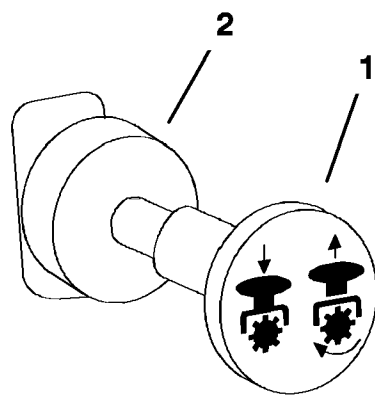

G000937

Figure 15

1. PTO-On 2. PTO-Off

Disengaging the PTO

To disengage, push the PTO switch to the **off** position (Figure 15).

The Safety Interlock System



If safety interlock switches are disconnected or damaged the machine could operate unexpectedly causing personal injury.

- Do not tamper with the interlock switches.
- Check the operation of the interlock switches daily and replace any damaged switches before operating the machine.

Understanding the Safety Interlock System

The safety interlock system is designed to prevent the engine from starting unless:

- You are sitting on the seat.
- The parking brake is engaged.
- The power take off (PTO) is disengaged.
- The motion control levers are in the neutral locked position

The safety interlock system also is designed to stop the engine when the traction controls are moved from the locked position with the parking brake engaged or if you rise from the seat when the PTO is engaged.

Testing the Safety Interlock System

Test the safety interlock system before you use the machine each time. If the safety system does not operate as described below, have an Authorized Service Dealer repair the safety system immediately.

1. Sitting on the seat, engage the parking brake and move the PTO to on. Try starting the engine; the engine should not crank.
2. Sitting on the seat, engage the parking brake and move the PTO to off. Move either motion control lever (out of neutral locked position). Try starting the engine; the engine should not crank. Repeat for other control lever.
3. Sitting on the seat, engage the parking brake, move the PTO switch to off and move the motion control levers to neutral lock position. Now start the engine. While the engine is running, release the parking brake, engage the

PTO and rise slightly from the seat; the engine should stop.

4. Sitting on the seat, engage the parking brake, move the PTO switch to off and move the motion control levers to neutral lock position. Now start the engine. While the engine is running, center either motion control and move (forward or reverse); the engine should stop. Repeat for other motion control.
5. Sitting on the seat, disengage the parking brake, move the PTO switch to off and move the motion control levers to neutral lock position. Try starting the engine; the engine should not crank.

Driving Forward or Backward

The throttle control regulates the engine speed as measured in rpm (revolutions per minute). Place the throttle control in the fast position for best performance. Always operate in the full throttle position when mowing.



Machine can spin very rapidly. Operator may lose control of machine and cause personal injury or damage to machine.

- Use caution when making turns.
- Slow the machine down before making sharp turns.

Driving Forward

1. Release the parking brake; refer to Releasing the Parking Brake in Operation, page 15.
2. Move the levers to the center, un-locked position.
3. To go forward, slowly push the motion control levers forward (Figure 16).

Note: The engine will kill if the traction control levers are moved with the parking brake engaged.

To go straight, apply equal pressure to both motion control levers (Figure 16).

To turn, move the motion control lever toward neutral in the direction you want to turn (Figure 16).

The farther you move the traction control levers in either direction, the faster the machine will move in that direction.

To stop, pull the motion control levers to the neutral position.

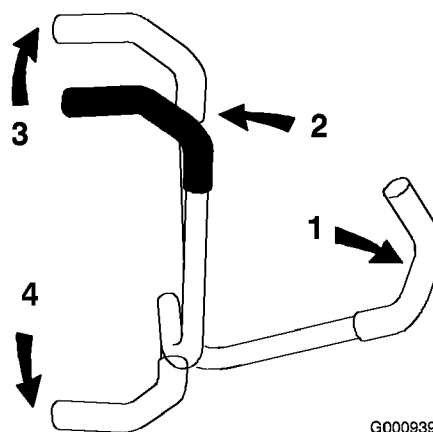

Figure 16

- | | |
|---|-------------|
| 1. Motion control lever-neutral lock position | 3. Forward |
| 2. Center un-lock position | 4. Backward |

Driving Backward

1. Move the levers to the center, un-locked position.
2. To go backward, slowly pull the motion control levers rearward (Figure 16).

To go straight, apply equal pressure to both motion control levers (Figure 16).

To turn, release pressure on the motion control lever toward the direction you want to turn (Figure 16).

To stop, push the motion control levers to the neutral position.

Stopping the Machine

To stop the machine, move the traction control levers to neutral and move to locked position, disengage the power take off (PTO), and turn the ignition key to off.

Set the parking brake when you leave the machine; refer to Setting the Parking Brake in Operation, page 15. Remember to remove the key from the ignition switch.



Children or bystanders may be injured if they move or attempt to operate the tractor while it is unattended.

Always remove the ignition key and set the parking brake when leaving the machine unattended, even if just for a few minutes.

Adjusting the Height-of-Cut

The height-of-cut is adjusted from 1-1/2 to 5 inch (38 to 127 mm) in 1/4 inch (6 mm) increments by relocating the clevis pin into different hole locations.

1. Raise the height-of-cut lever to the transport position (also the 5 inch (127 mm) cutting height position) (Figure 17).
2. To adjust, remove the clevis pin from the height-of-cut bracket (Figure 17).
3. Select a hole in the height-of-cut bracket corresponding to the height-of-cut desired and, insert the clevis pin (Figure 17).
4. Move the lever to the selected height.

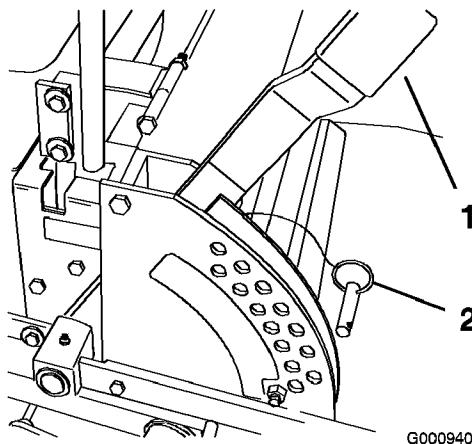

Figure 17

1. Height of cut lever
2. Clevis Pin

1. Disengage the PTO, move the motion control levers to the neutral locked position and set the parking brake.
2. Stop the engine, remove the key, and wait for all moving parts to stop before leaving the operating position.
3. After adjusting the height-of-cut, adjust the rollers by removing the flange nut, bushing, spacer, and bolt (Figure 18 , Figure 19 and Figure 20).

Note: The two middle rollers will not have a spacer (Figure 19).

4. Select a hole so the anti-scalp roller is positioned to the nearest corresponding height-of-cut desired.
5. Install the flange nut bushing, spacer, and bolt. Torque to 40-45 ft-lb (54-61 N•m) (Figure 18 , Figure 19 and Figure 20).
6. Repeat this adjustment on the other anti-scalp rollers.

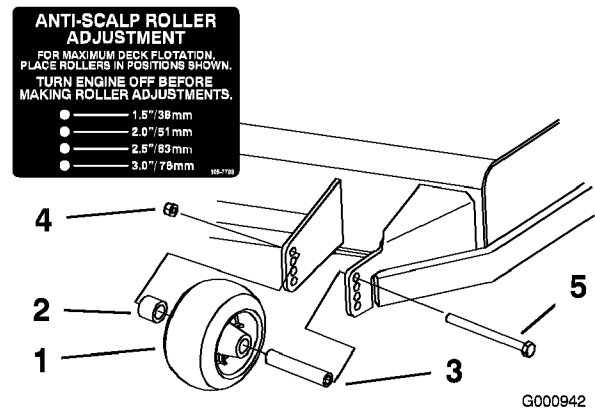

Figure 18

1. Anti-scalp roller
2. Spacer
3. Bushing
4. Flange Nut
5. Bolt

Adjusting the Anti-Scalp Rollers

Whenever you change the height-of-cut, it is recommended to adjust the height of the anti-scalp rollers.

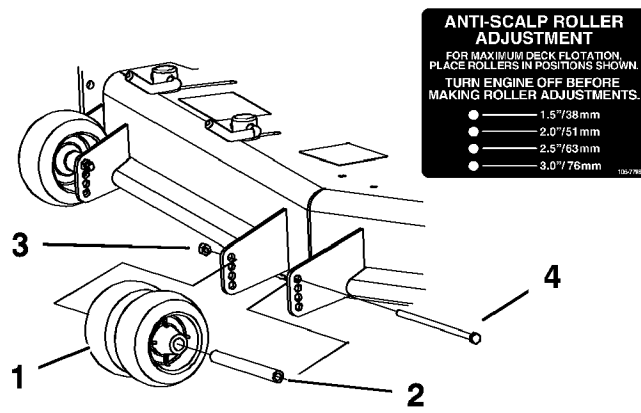

Figure 19

- | | |
|----------------------|---------------|
| 1. Anti-scalp roller | 3. Flange Nut |
| 2. Bushing | 4. Bolt |

- Swing the lever back over to tighten the baffle and cam locks (Figure 21).
- If the cams do not lock the baffle into place or it is too tight, loosen the lever and then rotate the cam lock. Adjust the cam lock until the desired locking pressure is achieved.

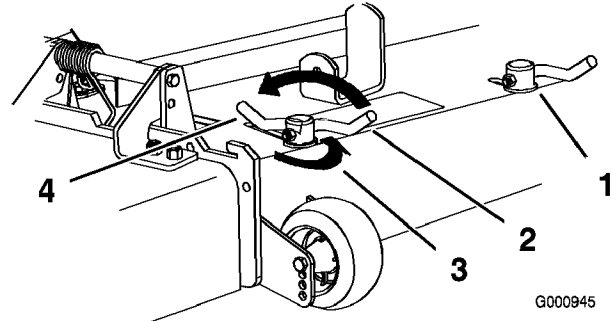

Figure 21

- | | |
|-------------|--|
| 1. Cam lock | 3. Rotate cam to increase or decrease locking pressure |
| 2. Lever | 4. Slot |

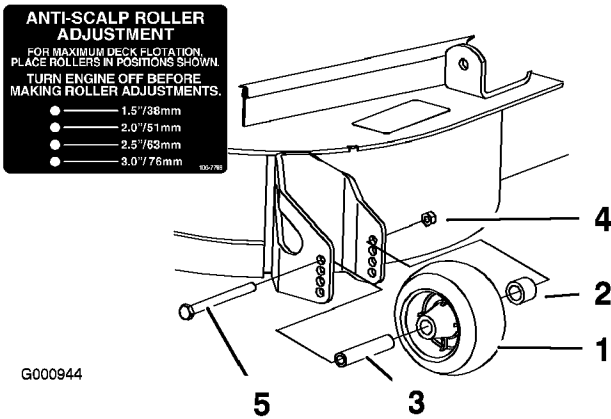

Figure 20

- | | |
|----------------------|---------------|
| 1. Anti-scalp roller | 4. Flange Nut |
| 2. Spacer | 5. Bolt |
| 3. Bushing | |

Adjusting the Flow Baffle

The mower discharge flow can be adjusted for different types of mowing conditions. Position the cam locks and baffle to give the best quality of cut.

- Disengage the PTO, move the motion control levers to the neutral locked position and set the parking brake.
- Stop the engine, remove the key, and wait for all moving parts to stop before leaving the operating position.
- To adjust the cam locks, swing the lever up to loosen the cam lock (Figure 21).
- Adjust the baffle and cam locks in the slots to the desired discharge flow.

Positioning the Flow Baffle

The following figures are only recommendations for use. Adjustments will vary by grass type, moisture content, and height of grass.

Note: If the engine power draws down and the mower ground speed is the same, open up the baffle.

Position A

This is the full rear position. The suggested use for this position is as follows.

- Use for short, light grass mowing conditions.
- Use in dry conditions.
- For smaller grass clippings.
- Propels grass clippings farther away from the mower.

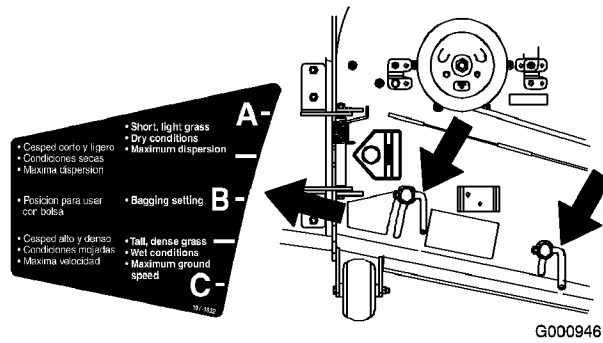

Figure 22

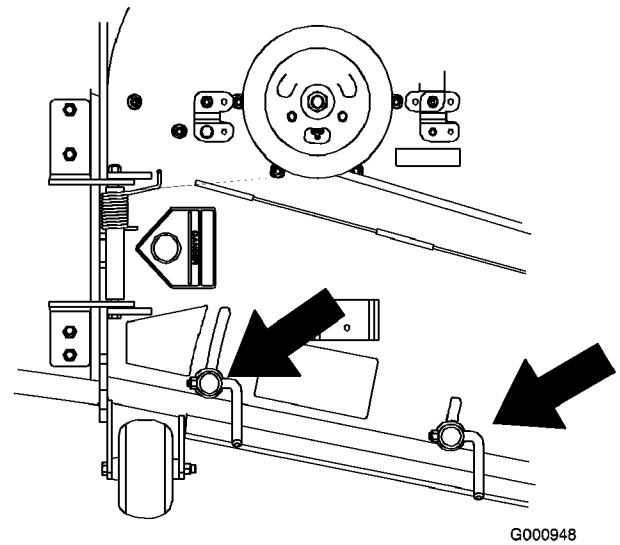

Figure 24

Position B

Use this position when bagging.

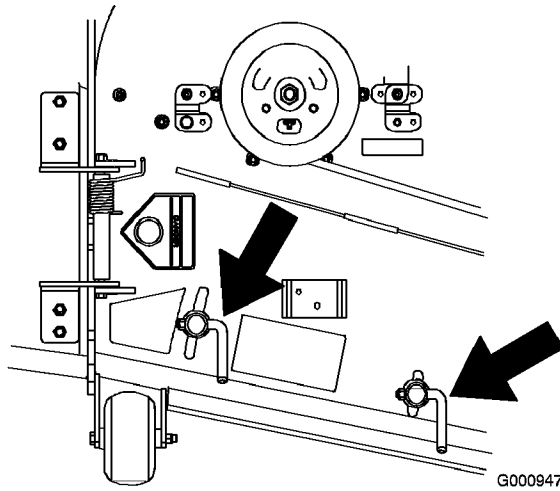

Figure 23

Position C

This is the full open position. The suggested use for this position is as follows.

- Use in tall, dense grass mowing conditions.
- Use in wet conditions.
- Lowers the engine power consumption.
- Allows increased ground speed in heavy conditions.
- This position is similar to the benefits of the Toro SFS mower.

Positioning the Seat

The seat can move forward and backward. Position the seat where you have the best control of the machine and are most comfortable.

Important: To adjust, move the lever sideways to unlock seat (Figure 25).

Slide the seat to the desired position and release lever to lock in position.

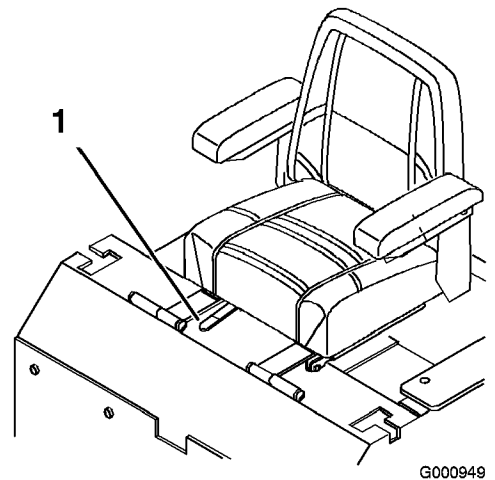

Figure 25

1. Adjustment lever

Unlatching the Seat

Push the seat latch rearward to unlatch the seat. This will allow access to the machine under the seat (Figure 26).

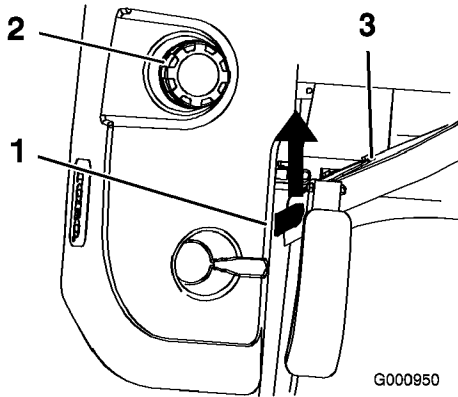

Figure 26

1. Seat latch
2. Fuel cap
3. Seat

The machine will not drive unless by-pass valves are turned in.

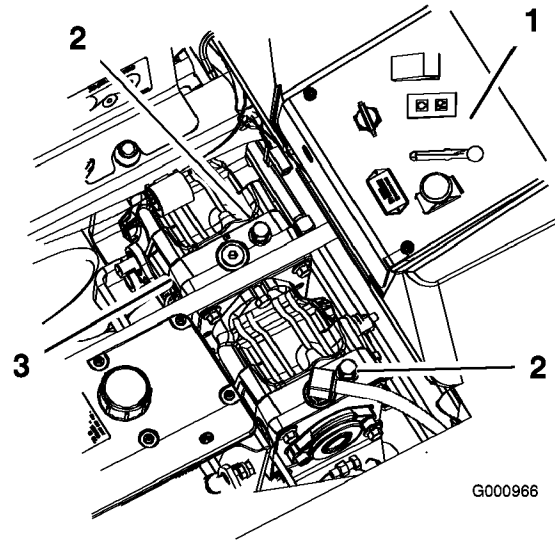

Figure 27

1. Side console controls
2. By-pass valve
3. Hydraulic pumps

Pushing the Machine by Hand

Important: Always push the machine by hand. Never tow the machine because hydraulic damage may occur.

Pushing the Machine

1. Disengage the power take off (PTO) and turn the ignition key to off. Move the levers to neutral locked position and apply parking brake. Remove the key.
2. Rotate the by-pass valves counterclockwise 1 turn to push. This allows hydraulic fluid to by-pass the pump enabling the wheels to turn (Figure 27).

Important: Do not rotate by-pass valves more than 1 turn. This prevents valves from coming out of the body and causing fluid to run out.

3. Disengage parking brake before pushing.

Changing to Machine Operation

Rotate the by-pass valves clockwise 1 turn to operate machine (Figure 27).

Note: Do not over tighten the by-pass valves.

Using the Side Discharge

The mower has a hinged grass deflector that disperses clippings to the side and down toward the turf.



Without the grass deflector, discharge cover, or complete grass catcher assembly mounted in place, you and others are exposed to blade contact and thrown debris. Contact with rotating mower blade(s) and thrown debris will cause injury or death.

- Never remove the grass deflector from the mower because the grass deflector routes material down toward the turf. If the grass deflector is ever damaged, replace it immediately.
- Never put your hands or feet under the mower.
- Never try to clear the discharge area or mower blades unless you move the power take off (PTO) to the off position, rotate the ignition key to off and remove the key.
- Make sure the grass deflector is in the down position.

Transporting Machines

Use a heavy-duty trailer or truck to transport the machine. Ensure that the trailer or truck has all necessary lighting and marking as required by law. Please carefully read all the safety instructions. Knowing this information could help you, your family, pets or bystanders avoid injury.

To transport the machine:

- Lock the brake and block the wheels.
- Securely fasten the machine to the trailer or truck with straps, chains, cable, or ropes.
- Secure a trailer to the towing vehicle with safety chains.



Driving on the street or roadway without turn signals, lights, reflective markings, or a slow moving vehicle emblem is dangerous and can lead to accidents causing personal injury.

Do not drive machine on a public street or roadway.

Loading Machines

Use extreme caution when loading units on trailers or trucks. One full width ramp that is wide enough to extend beyond the rear tires is recommended instead of individual ramps for each side of the unit (Figure 28). The lower rear section of the tractor frame extends back between the rear wheels and serves as a stop for tipping backward. Having a full width ramp provides a surface for the frame members to contact if the unit starts to tip backward. If it is not possible to use one full width ramp, use enough individual ramps to simulate a full width continuous ramp.

The ramp should be long enough so that the angles do not exceed 15 degrees (Figure 28). A steeper angle may cause mower components to get caught as the unit moves from ramp to trailer or truck. Steeper angles may also cause the unit to tip backward. If loading on or near a slope, position the trailer or truck so it is on the down side of the slope and the ramp extends up the slope. This will minimize the ramp angle. The trailer or truck should be as level as possible.

Important: Do Not attempt to turn the unit while on the ramp; you may lose control and drive off the side.

Avoid sudden acceleration when driving up a ramp and sudden deceleration when backing down a ramp. Both maneuvers can cause the unit to tip backward.



Loading a unit onto a trailer or truck increases the possibility of backward tip-over and could cause serious injury or death.

- Use extreme caution when operating a unit on a ramp.
- Use only a single, full width ramp; Do Not use individual ramps for each side of the unit.
- If individual ramps must be used, use enough ramps to create an unbroken ramp surface wider than the unit.
- Do not exceed a 15 degree angle between ramp and ground or between ramp and trailer or truck.
- Avoid sudden acceleration while driving unit up a ramp to avoid tipping backward.
- Avoid sudden deceleration while backing unit down a ramp to avoid tipping backward.

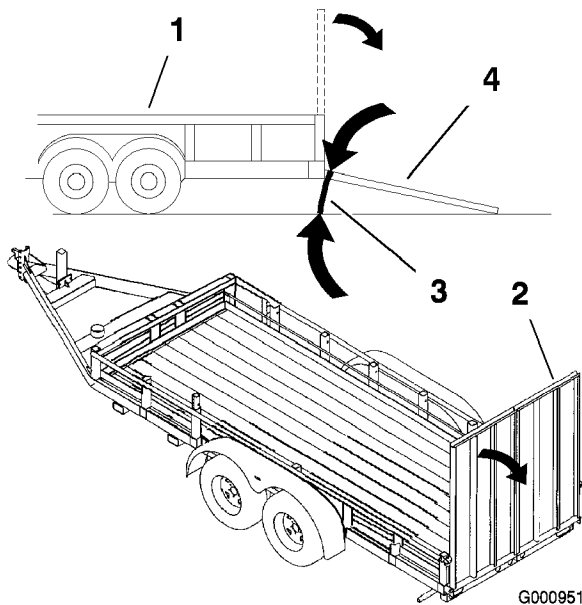

Figure 28

- | | |
|--------------------|--------------------------------|
| 1. Trailer | 3. Not greater than 15 degrees |
| 2. Full width ramp | 4. Full width ramp—side view |

Operating Tips

Fast Throttle Setting

For best mowing and maximum air circulation, operate the engine at the fast throttle position. Air is required to thoroughly cut grass clippings, so do not set the height-of-cut so low as to totally surround the mower by uncut grass. Always try to have one side of the mower free from uncut grass, which allows air to be drawn into the mower.

Cutting a Lawn for the First Time

Cut grass slightly longer than normal to ensure the cutting height of the mower does not scalp any uneven ground. However, the cutting height used in the past is generally the best one to use. When cutting grass longer than six inches tall, you may want to cut the lawn twice to ensure an acceptable quality of cut.

Cut 1/3 of the Grass Blade

It is best to cut only about 1/3 of the grass blade. Cutting more than that is not recommended unless grass is sparse, or it is late fall when grass grows more slowly.

Mowing Direction

Alternate mowing direction to keep the grass standing straight. This also helps disperse clippings which enhances decomposition and fertilization.

Mow at Correct Intervals

Normally, mow every four days. But remember, grass grows at different rates at different times. So to maintain the same cutting height, which is a good practice, mow more often in early spring. As the grass growth rate slows in mid summer, mow less frequently. If you cannot mow for an extended period, first mow at a high cutting height; then mow again two days later at a lower height setting.

Cutting Speed

To improve cut quality, use a slower ground speed in certain conditions.

Avoid Cutting Too Low

If the cutting width of the mower is wider than the mower you previously used, raise the cutting height to ensure that uneven turf is not cut too short.

Long Grass

If the grass is ever allowed to grow slightly longer than normal, or if it contains a high degree of moisture, raise the cutting height higher than usual and cut the grass at this setting. Then cut the grass again using the lower, normal setting.

When Stopping

If the machine's forward motion must be stopped while mowing, a clump of grass clippings may drop onto your lawn. To avoid this, move onto a previously cut area with the blades engaged.

Keep the Underside of the Mower Clean

Clean clippings and dirt from the underside of the mower after each use. If grass and dirt build up inside the mower, cutting quality will eventually become unsatisfactory.

Blade Maintenance

Maintain a sharp blade throughout the cutting season because a sharp blade cuts cleanly without tearing or shredding the grass blades. Tearing and shredding turns grass brown at the edges, which slows growth and increases the chance of disease. Check the cutter blades daily for sharpness, and for any wear or damage. File down any nicks and sharpen the blades as necessary. If a blade is damaged or worn, replace it immediately with a genuine TORO replacement blade.

Maintenance

Recommended Maintenance Schedule(s)

Maintenance Service Interval	Maintenance Procedure
After the first 8 operating hours	<ul style="list-style-type: none"> • Check cooling system level. • Check the hydraulic fluid.
After the first 25 operating hours	<ul style="list-style-type: none"> • Change the hydraulic filter and oil.
After the first 50 operating hours	<ul style="list-style-type: none"> • Change the engine oil. • Change the engine oil filter.
After the first 100 operating hours	<ul style="list-style-type: none"> • Change gear box oil.
Before each use or daily	<ul style="list-style-type: none"> • Check the safety system. • Check the engine oil. • Check cooling system level. • Clean the engine oil cooler. • Check the mower blades. • Clean the mower deck.
Every 25 hours	<ul style="list-style-type: none"> • Grease the mower deck and spindles. • Grease the mower belt idler arm. • Grease the pump belt idler arm. • Grease the drive belt idler arm. • Grease the brake lever. • Check the hydraulic fluid.
Every 50 hours	<ul style="list-style-type: none"> • Check the tire pressure. • Check the PTO drive belt. • Check the pump drive belt. • Check the alternator belt.
Every 100 hours	<ul style="list-style-type: none"> • Change the engine oil. • Check the gear box oil level. • Check the cooling system hoses. • Inspect the belts for cracks and wear. • Check the hydraulic hoses.
Every 150 hours	<ul style="list-style-type: none"> • Lubricate the machine with light oil (Refer to Lubrication).
Every 200 hours	<ul style="list-style-type: none"> • Change the engine oil filter. • Grease the brake pivot.
Every 250 hours	<ul style="list-style-type: none"> • Check and/or replace the air filter (more often in dirty or dusty conditions).
Every 400 hours	<ul style="list-style-type: none"> • Replace the fuel filters.
Every 500 hours	<ul style="list-style-type: none"> • Check the wheel hub slotted nut. • Adjust the caster pivot bearing.
Yearly	<ul style="list-style-type: none"> • Grease the front caster pivots (more often in dirty or dusty conditions). • Change the gear box oil. • Change the engine coolant. • Change the hydraulic filter and oil.

Important: Refer to your engine operator's manual for additional maintenance procedures.



If you leave the key in the ignition switch, someone could accidentally start the engine and seriously injure you or other bystanders.

Remove the key from the ignition and disconnect the wire from the spark plug(s) before you do any maintenance. Set the wire aside so that it does not accidentally contact the spark plug.

Lubrication

Greasing and Lubrication

Lubricate the machine when shown on the Check Service Reference Aid decal (Figure 29). Grease more frequently when operating conditions are extremely dusty or sandy.

Grease Type: General-purpose grease.

How to Grease

1. Disengage the PTO, move the motion control levers to the neutral locked position and set the parking brake.
2. Stop the engine, remove the key, and wait for all moving parts to stop before leaving the operating position.
3. Clean the grease fittings with a rag. Make sure to scrape any paint off the front of the fitting(s).
4. Connect a grease gun to the fitting. Pump grease into the fittings until grease begins to ooze out of the bearings.
5. Wipe up any excess grease.

Greasing the Front Caster Pivots

Lubricate the front caster pivots once a year.

1. Remove the dust cap and adjust the caster pivots. Keep the dust cap off until greasing is done. Refer to Adjusting the Caster Pivot Bearing in Drive System Maintenance, page 40.
2. Remove the hex plug. Thread a grease zerk into the hole.
3. Pump grease into the zerk until it oozes out around the top bearing.
4. Remove the grease zerk in the hole. Install the hex plug and cap.

Where to Add Grease

Lubricate the grease fittings as shown on the Check Service Reference Aid decal (Figure 29).

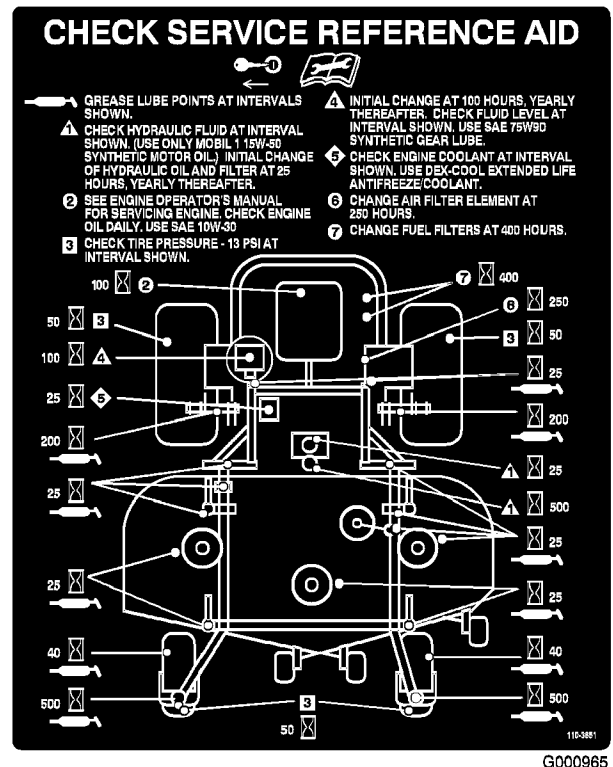

Figure 29

Where to Add Light Oil or Spray Lubrication

Lubricate the machine in the following areas with spray type lubricant or light oil. Lubricate every 150 hours.

- Seat switch actuator.
- Brake handle pivot.
- Brake rod bushings.
- Motion control bronze bushings.

Greasing the Mower Deck and Belt Idlers

The mower deck must be lubricated weekly or every 25 hours. Grease with No. 2 general purpose lithium base or molybdenum base grease.

Important: Make sure cutting unit spindles are full of grease weekly.

1. Disengage the PTO, move the motion control levers to the neutral locked position and set the parking brake.
2. Stop the engine, remove the key, and wait for all moving parts to stop before leaving the operating position.
3. Remove the belt covers.
4. Grease the three spindle bearings under the pulleys until grease comes out the lower seals (Figure 30).
5. Grease the idler arm on the mower deck (Figure 30).
6. Grease the fittings on the push arms (Figure 30).

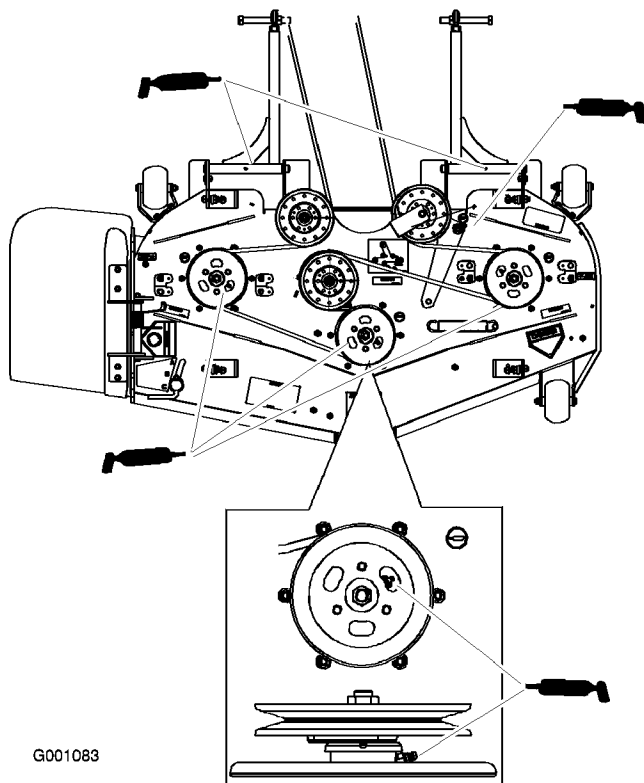

Figure 30

7. Grease the PTO drive belt idler arm (Figure 31).
8. Grease the pump belt idler arm (Figure 31).

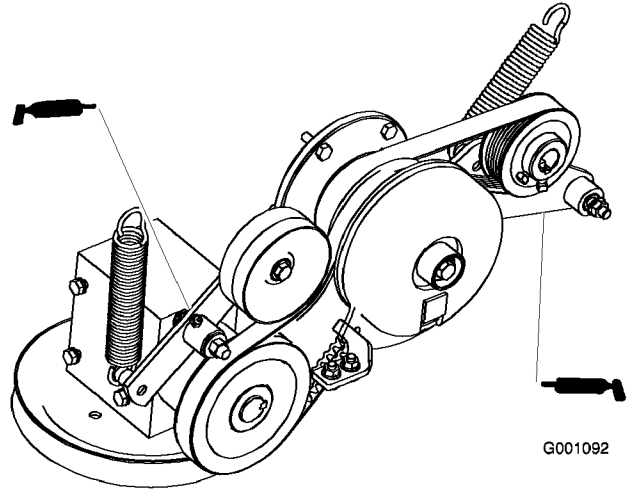

Figure 31

Engine Maintenance

Servicing the Air Cleaner

Air Filter: Check and/or replace after every 250 operating hours or more often in dusty conditions.

Note: Check the filters more frequently if operating conditions are extremely dusty or sandy.

Removing the Air Filter

1. Disengage the PTO, move the motion control levers to the neutral locked position and set the parking brake.
2. Stop the engine, remove the key, and wait for all moving parts to stop before leaving the operating position.
3. Release the latches on the air cleaner and pull the air cleaner cover off of the air cleaner body (Figure 32).
4. Clean the inside of the air cleaner cover with compressed air.
5. Gently slide the filter out of the air cleaner body (Figure 32). Avoid knocking the filter into the side of the body.
6. Inspect the filter for damage by looking into the filter while shining a bright light on the outside of the filter. Holes in the filter will

appear as bright spots. If the filter is damaged discard it.

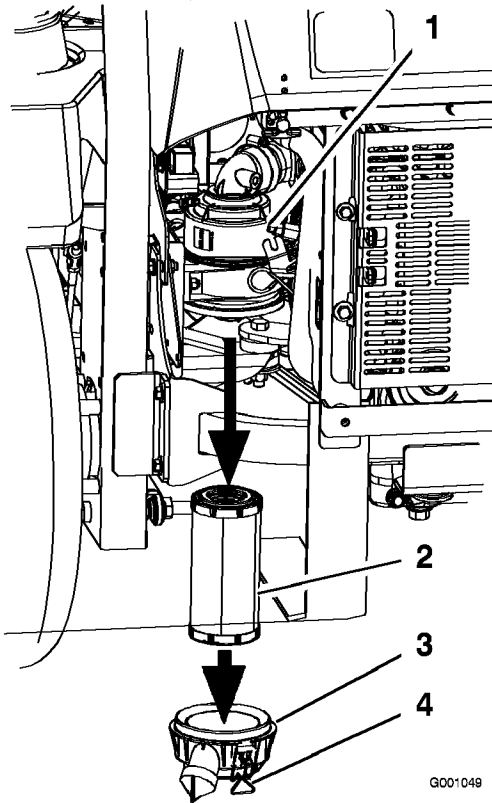

Figure 32

- | | |
|--------------------|----------------------|
| 1. Air filter body | 3. Air cleaner cover |
| 2. Air filter | 4. Latches |

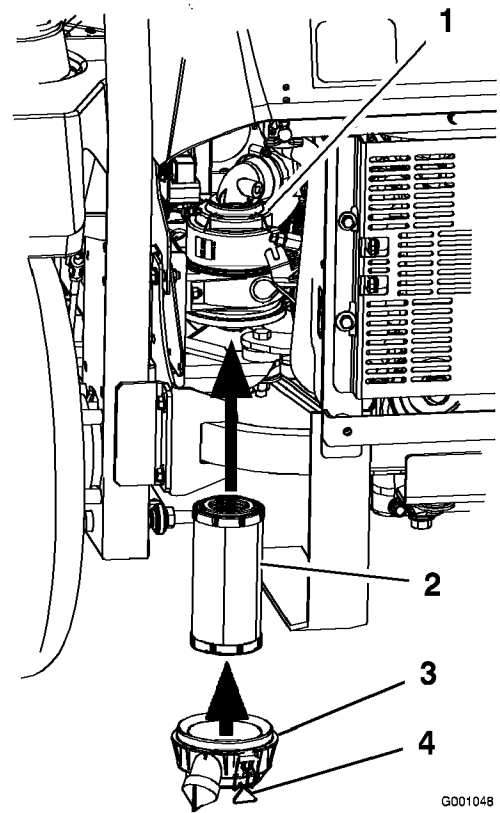

Figure 33

- | | |
|--------------------|----------------------|
| 1. Air filter body | 3. Air cleaner cover |
| 2. Air filter | 4. Latches |

Installing the Air Filter

1. If installing a new filter, check the filter for shipping damage. Do not use a damaged filter.
2. Carefully slide the filter into the filter body (Figure 33). Ensure that it is fully seated by pushing on the outer rim of the filter while installing it.

Important: Do not press on the soft inside area of the filter.

3. Install the air cleaner cover and secure the latches (Figure 33).

Servicing the Engine Oil

Change engine oil:

- Change the engine oil after the first 50 operating hours.
- Change the engine oil after every 100 operating hours.

Oil Type: High-quality detergent oil classified API Service CD or higher for diesel engines. Do not use special additives with recommended oils.

Crankcase Capacity: 3.9 quarts (3.7 liters)

Viscosity: See the table below.

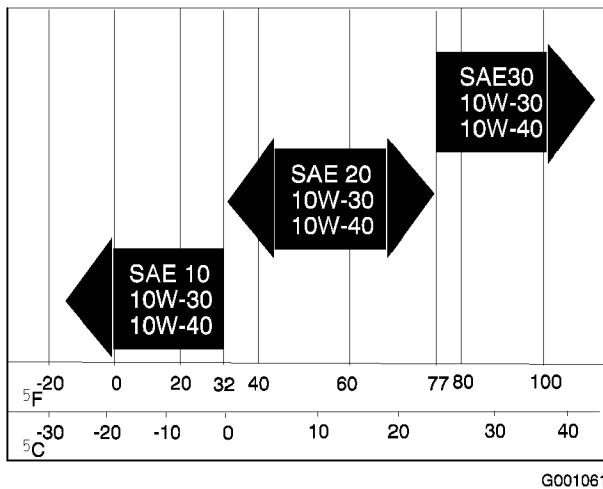

Figure 34

Checking the Engine Oil Level

Note: Check the oil when the engine is cold.

1. Disengage the PTO, move the motion control levers to the neutral locked position and set the parking brake.
2. Stop the engine, remove the key, and wait for all moving parts to stop before leaving the operating position.
3. Clean around the oil dipstick (Figure 35) so dirt cannot fall into the filler hole and damage the engine.
4. Pull the oil dipstick out and wipe the metal end clean (Figure 35).
5. Slide the oil dipstick fully into the filler tube. Pull the dipstick out and look at the metal end (Figure 35). If the oil level is low, slowly pour only enough oil into the fill hole to raise the level to the full mark.

Important: Do not overfill the crankcase with oil because this may cause engine damage. Do not run the engine with oil below the low mark because the engine may be damaged as a result.

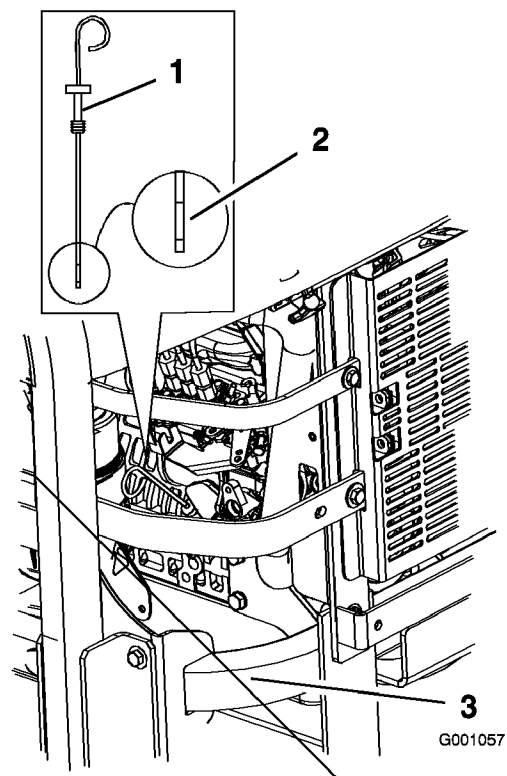

Figure 35

1. Oil dipstick
2. Metal end
3. Rear left side of machine

Changing the Engine Oil

1. Start the engine and let it run for five minutes. This warms the oil so it drains better.
2. Park the machine on a level surface.
3. Disengage the PTO, move the motion control levers to the neutral locked position and set the parking brake.
4. Stop the engine, remove the key, and wait for all moving parts to stop before leaving the operating position.
5. Place a pan below the oil drain. Remove the drain plug and let the oil drain completely (Figure 36).
6. Remove the oil filler cap from the top of the engine (Figure 38). This will help the oil to drain.
7. Install the drain plug and tighten it to 25-1/2 ft-lb (35 N•m).

Note: Dispose of the used oil at a recycling center.

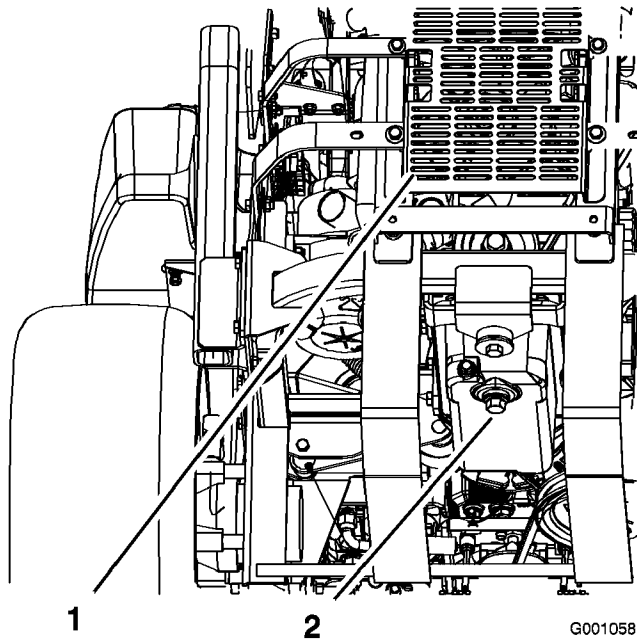

Figure 36

- 1. Back of machine
- 2. Drain plug

Adding Engine Oil

1. Tilt the seat forward and remove the front engine panel (Figure 37).

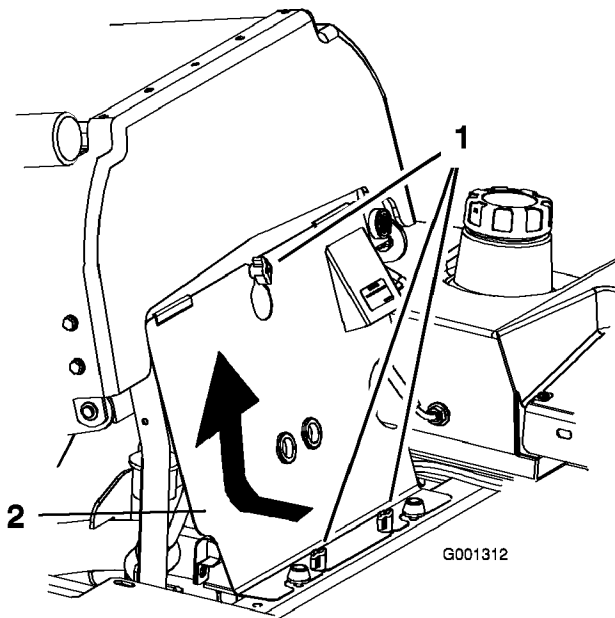

Figure 37

- 1. Knob
- 2. Front engine panel

2. Remove the oil filler cap and the dipstick (Figure 38).

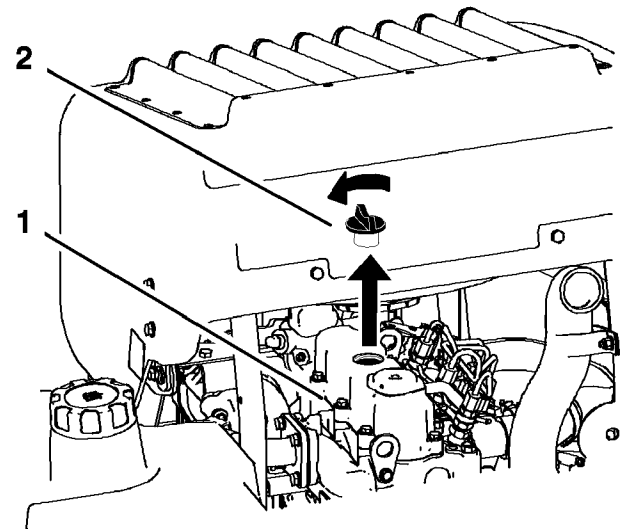

Figure 38

- 1. Engine
- 2. Oil fill cap

3. To add oil to the engine, locate and use a hose and funnel for adding oil (Figure 39).
4. Add oil slowly, checking the level with the dipstick frequently until the level reaches the upper hole on the dipstick. For the correct oil type and viscosity to use in different temperature conditions, refer to Servicing the Engine Oil in Engine Maintenance, page 32,).

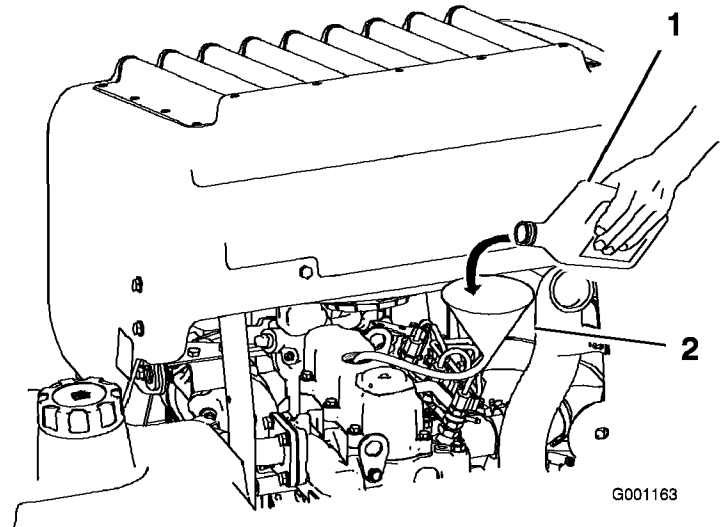
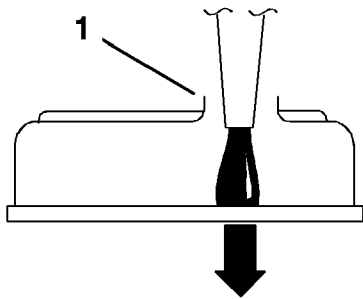

Figure 39

- 1. Engine oil
- 2. Funnel and hose

Important: Add the oil very slowly and do not block the opening of the filler hole (Figure 40). If you add oil too fast or block the hole, the oil could back up and foul the air intakes, causing engine damage.



G000955

Figure 40

1. Note the clearance left in the filler opening.

5. Replace the dipstick and install the front engine panel.
6. Start the engine and run it at idle for 5 minutes.
7. Shut off the engine.
8. Wait 3 minutes and check the oil level.
9. Add oil, if required, to bring the level to the upper hole on the dipstick.
10. Replace the dipstick and , filler cap, and the front engine panel.
11. Check for leaks.

Important: Do not overfill the crankcase with oil because this may cause engine damage.

Changing the Engine Oil Filter

Replace the oil filter after the first 50 operating hours and then every 200 operating hours thereafter.

1. Drain the oil from the engine; refer to Changing the Engine Oil.

Place a drip pan beneath the oil drip tray to receive oil from the oil filter and oil passages in the engine.

2. Turn the filter counterclockwise to remove it (Figure 41 and Figure 42).

Note: Dispose of the oil filter properly. Recycle in accordance with local codes.

3. Before installing the filter, lightly oil the gasket on the filter with fresh, clean oil. Screw the

filter on by hand until the gasket contacts the oil filter adapter. Tighten 1/2 to 3/4 turn more.

4. Add oil; refer to Adding Engine Oil.

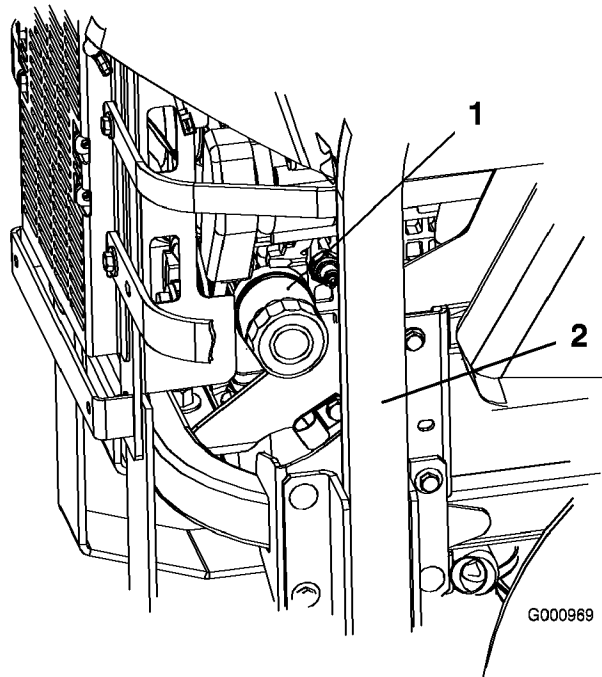

G000969

Figure 41

1. Oil filter
2. Right side of machine

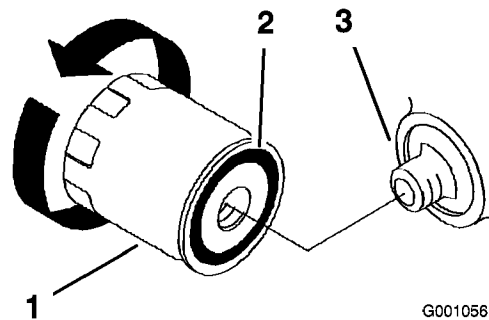

G001056

Figure 42

1. Oil filter
2. Gasket
3. Adapter

Fuel System Maintenance

Servicing the Fuel Filters

Replace the fuel filters after every 400 operating hours or yearly, whichever occurs first, and replace

them more frequently under extremely dusty or dirty conditions.

Replacing the Fuel Filter

Ensure that an Authorized Service Dealer replaces the fuel filter and any components for the fuel system.



Use of improper components can result in system failure, fuel leakage and possible explosion.

- Ensure that an Authorized Service Dealer replace the fuel filter and any components for the fuel system.
- Use only approved fuel lines, hose clamps and fuel filters for high pressure systems.

Servicing the Fuel Tank

Do not attempt to drain the fuel tank. Ensure that an Authorized Service Dealer drains the fuel tank and services any components of the fuel system.

Electrical System Maintenance

Servicing the Battery

Warning

CALIFORNIA
Proposition 65 Warning

Battery posts, terminals, and related accessories contain lead and lead compounds, chemicals known to the State of California to cause cancer and reproductive harm. Wash hands after handling.



Battery electrolyte contains sulfuric acid which is a deadly poison and causes severe burns.

Do not drink electrolyte and avoid contact with skin, eyes or clothing. Wear safety glasses to shield your eyes and rubber gloves to protect your hands.

Removing the Battery



Battery terminals or metal tools could short against metal machine components causing sparks. Sparks can cause the battery gasses to explode, resulting in personal injury.

- When removing or installing the battery, do not allow the battery terminals to touch any metal parts of the machine.
- Do not allow metal tools to short between the battery terminals and metal parts of the machine.



Incorrect battery cable routing could damage the machine and cables causing sparks. Sparks can cause the battery gasses to explode, resulting in personal injury.

- Always Disconnect the negative (black) battery cable before disconnecting the positive (red) cable.
- Always Reconnect the positive (red) battery cable before reconnecting the negative (black) cable.

1. Disengage the PTO, move the motion control levers to the neutral locked position and set the parking brake.
2. Stop the engine, remove the key, and wait for all moving parts to stop before leaving the operating position.
3. Unlatch the seat and tilt the seat up.
4. First disconnect the negative battery cable from the negative (-) battery terminal (Figure 43).

- Slide the red terminal boot off the positive (red) battery terminal. Then remove the positive (red) battery cable (Figure 43).

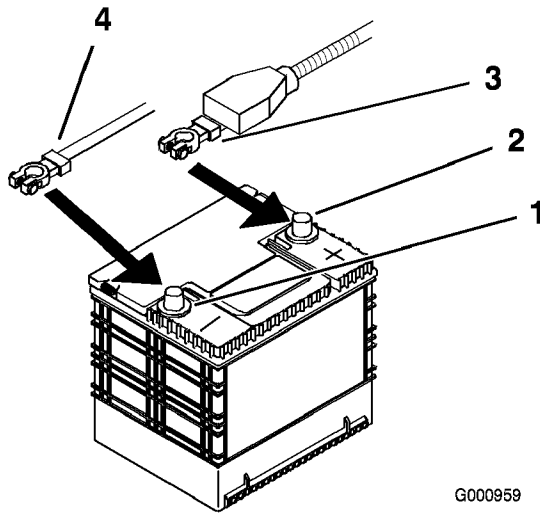

Figure 43

- | | |
|--------------------------|--------------------|
| 1. Negative Battery Post | 3. Red (+) cable |
| 2. Positive Battery Post | 4. Black (-) cable |

- Remove both wing nuts (1/4 inch) securing the battery clamp (Figure 44).
- Remove the two bolts holding the hydraulic tank in place (Figure 44).
- Slide the hydraulic tank away from the battery.
- Remove the battery.

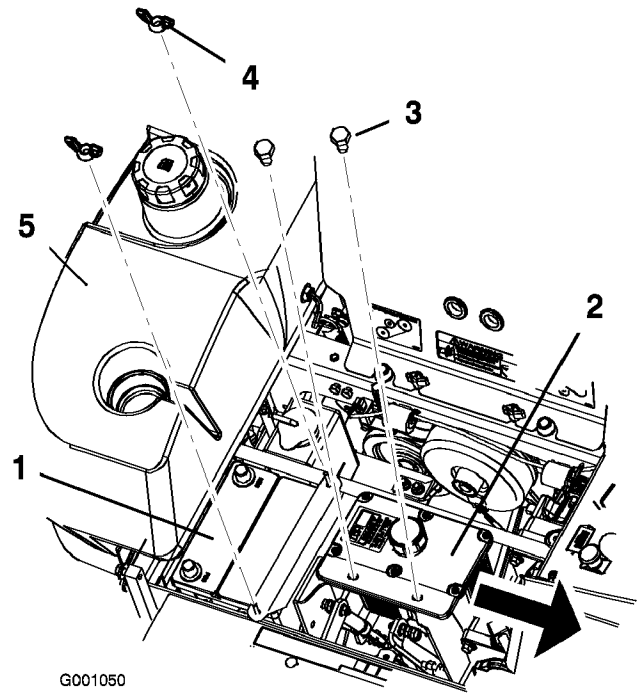

Figure 44

- | | |
|-------------------|-------------------------|
| 1. Battery | 4. Wing nut |
| 2. Hydraulic tank | 5. Right side fuel tank |
| 3. Bolts | |

Installing the Battery

- Position battery in the tray with the terminal posts opposite from the hydraulic tank (Figure 43).
- First, install the positive (red) battery cable to positive (+) battery terminal.
- Then install the negative battery cable and ground wire to the negative (-) battery terminal.
- Secure the cables with 2 bolts (1/4 x 3/4 inch), 2 washers (1/4 inch), and 2 locknuts (1/4 inch) (Figure 43).
- Slide the red terminal boot onto the positive (red) battery post.
- Secure battery with J-bolts, hold down clamp and 2 washers (1/4 inch), and 2 wing nuts (1/4 inch) (Figure 44).

Charging the Battery



Charging the battery produces gasses that can explode.

Never smoke near the battery and keep sparks and flames away from battery.

Important: Always keep the battery fully charged (1.265 specific gravity). This is especially important to prevent battery damage when the temperature is below 32°F (0°C).

1. Make sure the filler caps are installed in battery. Charge battery for 10 to 15 minutes at 25 to 30 amps or 30 minutes at 10 amps.
2. When the battery is fully charged, unplug the charger from the electrical outlet, then disconnect the charger leads from the battery posts (Figure 45).
3. Install the battery in the machine and connect the battery cables, refer to Installing the Battery.

Note: Do not run the machine with the battery disconnected, electrical damage may occur.

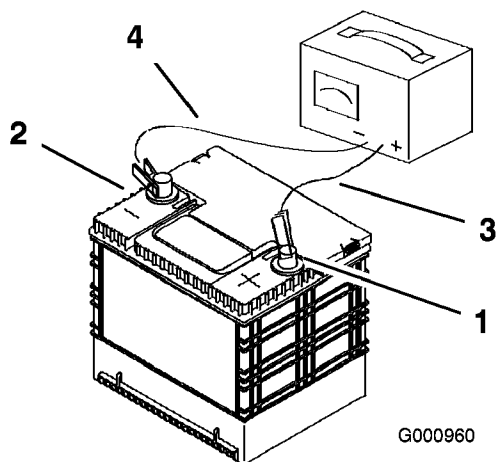

Figure 45

- | | |
|--------------------------|---------------------------|
| 1. Positive Battery Post | 3. Red (+) Charger Lead |
| 2. Negative Battery Post | 4. Black (-) Charger Lead |

Fuse:

- Ignition, F1-30 amp, blade-type
 - Radiator fan, F2-30 amp, blade-type
1. Unlatch the engine hood and raise the engine hood to gain access to fuse holder (Figure 46).
 2. To replace the fuses, pull out on the fuse to remove it.
 3. Install a new fuse (Figure 46).

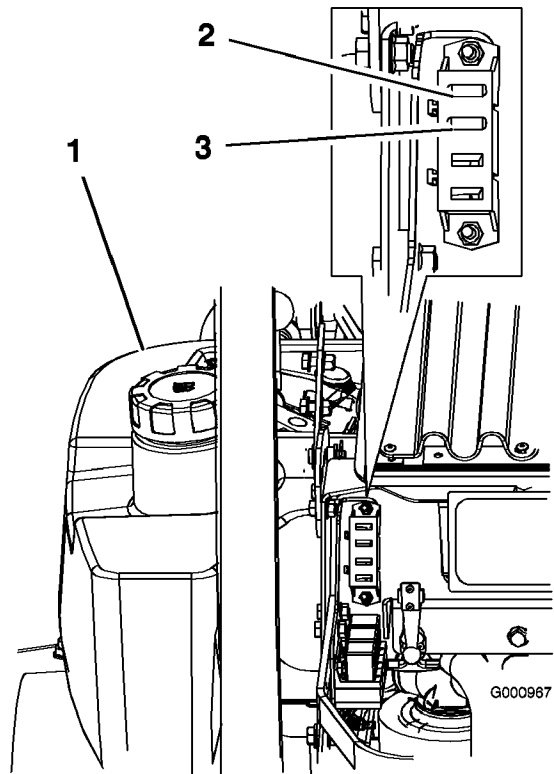

Figure 46

- | | |
|------------------------|-----------------------|
| 1. Left side fuel tank | 3. Radiator fan-30amp |
| 2. Ignition-30 amp | |

Servicing the Fuses

The electrical system is protected by fuses. It requires no maintenance, however, if a fuse blows check component/circuit for malfunction or short.

Drive System Maintenance

Adjusting the Tracking

The machine has a knob for adjusting the tracking located under the seat.

Important: Adjust the handle neutral and hydraulic pump neutral before adjusting the tracking. Refer to **Adjusting the Handle Neutral in Controls System Maintenance, page 48** and **Adjusting the Hydraulic Pump Neutral in Hydraulic System Maintenance, page 49**.

1. Push both control levers forward the same distance.
2. Check if the machine pulls to one side. If it does, stop the machine and set the parking brake.
3. Unlatch the seat and tilt the seat forward to access the tracking knob.

Note: Determine the left and right sides of the machine from the normal operating position.

4. To make the machine go right, turn the knob towards the rightside of the machine. Refer to Figure 47.
5. To make the machine go left, turn the knob towards the leftside of the machine. Refer to Figure 47.
6. Repeat adjustment until the tracking is correct.

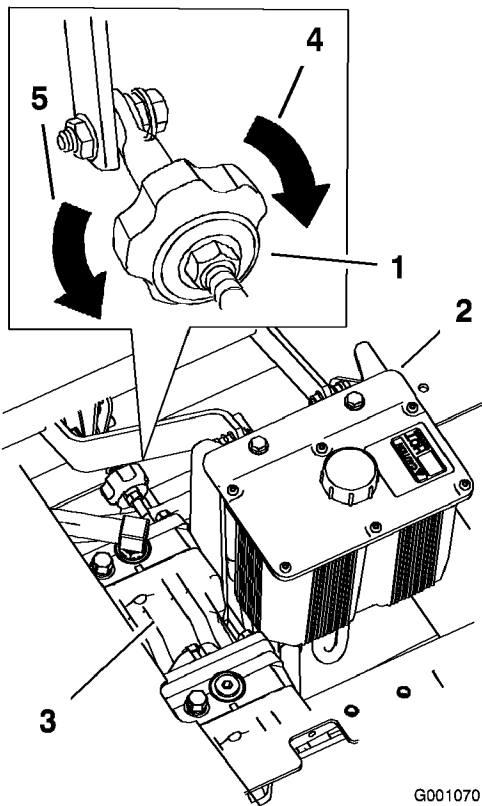

Figure 47

- | | |
|--------------------|---------------------------------|
| 1. Tracking knob | 4. Turn this way to track right |
| 2. Hydraulic tank | 5. Turn this way to track left |
| 3. Hydraulic pumps | |

Checking the Tire Pressure

Check the pressure at the valve stem after every 50 operating hours or monthly, whichever occurs first (Figure 48).

Maintain the air pressure in the front and rear tires as specified. Uneven tire pressure can cause uneven cut. Check the tires when they are cold to get the most accurate pressure reading.

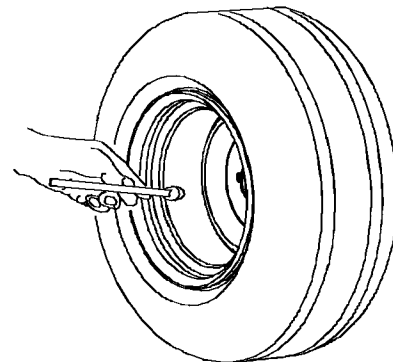

G001055

Figure 48

Checking the Wheel Hub Slotted Nut

Check after every 500 operating hours.

The slotted nut needs to be torqued to 125 ft-lb (170 N•m).

1. Disengage the PTO, move the motion control levers to the neutral locked position and set the parking brake.
2. Stop the engine, remove the key, and wait for all moving parts to stop before leaving the operating position.
3. Remove the cotter pin.
4. Torque the slotted nut to 125 ft-lb (170 N•m) (Figure 49).

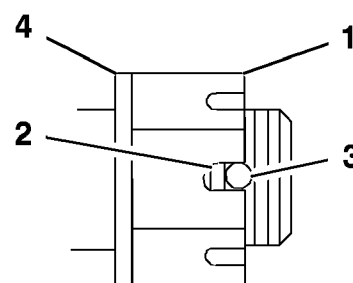

G001051

Figure 49

- | | |
|--------------------------------|---------------------------|
| 1. Slotted Nut | 3. Hole in threaded shaft |
| 2. Two threads or less showing | 4. Washer (if needed) |

5. Check the distance from bottom of slot in nut to inside edge of hole. Two threads or less should be showing (Figure 49).
6. If more than two threads are showing remove nut and install washer between hub and nut.

7. Torque the slotted nut to 125 ft-lb. (170 N•m) (Figure 49).
8. Tighten the nut until the next set of slots line up with the hole in the shaft (Figure 49).
9. Replace the cotter pin.

Adjusting the Caster Pivot Bearing

Check after every 500 operating hours or at storage, whichever comes first.

1. Disengage the PTO, move the motion control levers to the neutral locked position and set the parking brake.
2. Stop the engine, remove the key, and wait for all moving parts to stop before leaving the operating position.
3. Remove the dust cap from caster and tighten lock nut (Figure 50).
4. Tighten the locknut until the spring washers are flat and then back off a 1/4 turn to properly set the pre-load on the bearings (Figure 50).

Important: Make sure spring washers are installed correctly as shown in Figure 50.

5. Install the dust cap (Figure 50).

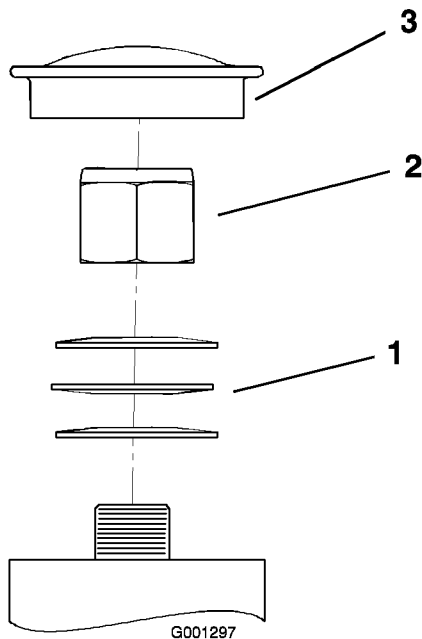

Figure 50

- | | |
|-------------------|-------------|
| 1. Spring Washers | 3. Dust Cap |
| 2. Lock Nut | |

Servicing the Gear Box

Checking the Gear Box Oil Level

Use SAE 75W-90 Synthetic Gear Lube.

1. Park the machine on a level surface.
2. Disengage the PTO, move the motion control levers to the neutral locked position and set the parking brake.
3. Stop the engine, remove the key, and wait for all moving parts to stop before leaving the operating position.
4. Remove the side or rear plug on the gear box. (Figure 51).
5. The oil should be up to the opening of the gear box.
6. Add oil if needed to bring it to the correct level.

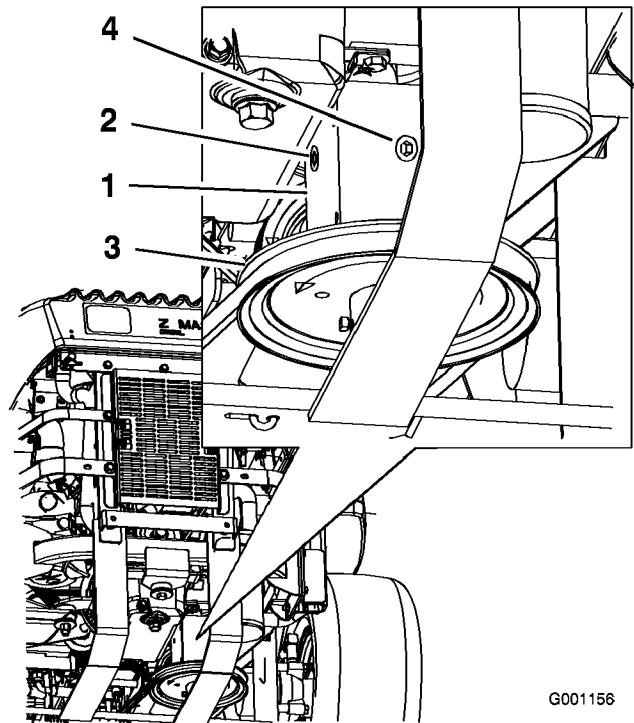

Figure 51

- | | |
|--------------|--------------|
| 1. Gear box | 3. Pulley |
| 2. Side plug | 4. Rear plug |

Changing the Gear Box Oil

Contact an Authorized Service Dealer to change the gear box oil.

Cooling System Maintenance

Servicing the Cooling System



Discharge of hot pressurized coolant or touching hot radiator and surrounding parts can cause severe burns.

- Do not remove the radiator cap when the engine is hot. Always allow the engine to cool at least 15 minutes or until the radiator cap is cool enough to touch without burning your hand before removing the radiator cap.
- Do not touch radiator and surrounding parts that are hot.



Rotating shaft and fan can cause personal injury.

- Do not operate the machine without the covers in place.
- Keep fingers, hands and clothing clear of rotating fan and drive shaft.
- Shut off the engine and remove the ignition key before performing maintenance.



Swallowing engine coolant can cause poisoning.

- Do not swallow engine coolant.
- Keep out of reach from children and pets.

Checking the Radiator Coolant

Check the cooling system level daily.

Check the cooling system hoses every 100 hours.

Fluid Type: 50/50 mix of extended life antifreeze/Dex-Cool® and water

Cooling System Capacity: 156 ounces (4.6 l)

Note: Do not open the radiator cap. Doing this may induce air into the cooling system.

1. Position the machine on a level surface, stop the engine, and set the parking brake.
2. Unlatch the seat and tilt the seat up.
3. With the engine cool, check the overflow bottle level. The fluid needs to be up to the bump on the outside of the overflow bottle (Figure 52).
4. If the coolant level is low, add a 50/50 mix of extended life antifreeze/Dex-Cool® and water to the overflow bottle (Figure 52).
5. Add the 50/50 coolant mix to the overflow bottle and fill it to the indicator line on the bottle (Figure 52).

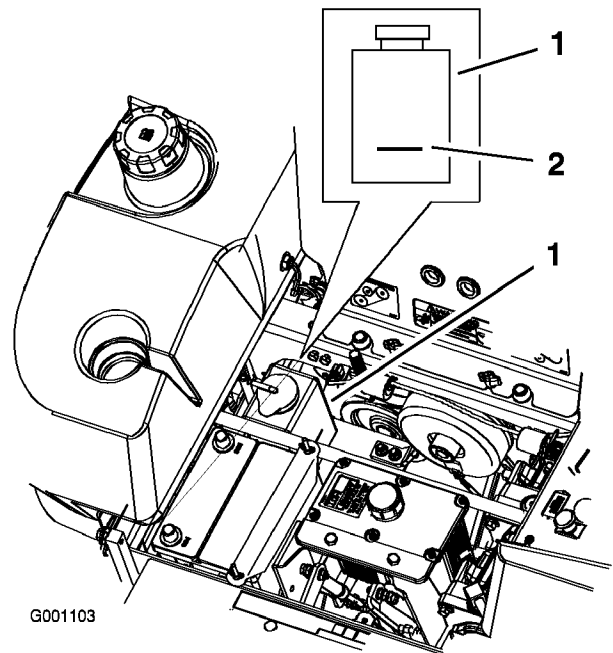

Figure 52

1. Antifreeze overflow bottle
2. Indicator line on side of overflow bottle

Cleaning the Hydraulic Oil Cooler and Radiator Screen

Before each use, check and clean the radiator screen and oil cooler. Remove any build-up of grass, dirt or other debris from the oil cooler and radiator screen with compressed air (Figure 53).

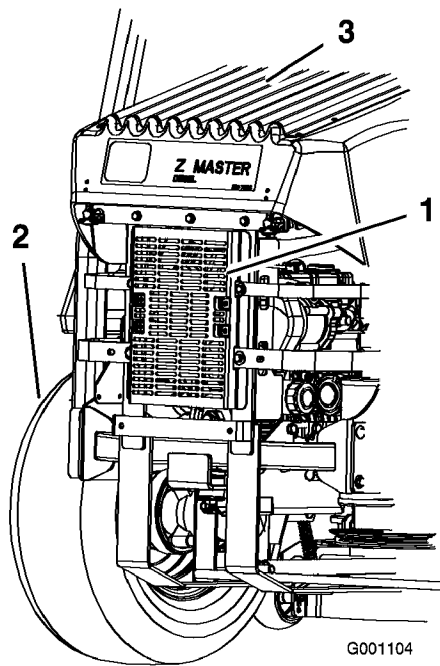

Figure 53

- | | |
|-------------------------|--------------------|
| 1. Hydraulic oil cooler | 3. Radiator screen |
| 2. Left rear tire | |

Changing the Engine Coolant

Change the engine coolant yearly.

Contact an Authorized Service Dealer for changing the coolant.

Brake Maintenance

Adjusting the Parking Brake

1. Engage the parking brake, lever up.
2. Measure the length of the spring. Measurement should be 2-1/2 inch (64 mm) between the washers (Figure 54).
3. If adjustment is necessary, release the parking brake, loosen the jam nut below the spring and adjust the nut directly below the spring (Figure 54). Turn the nut until the correct measurement is obtained. Turn the nut clockwise to shorten spring length and turn counter-clockwise to lengthen the spring.
4. Tighten the two nuts together.
5. Engage the parking brake, lever up. Check the measurement of the spring again.

6. If adjustment is necessary, repeat the procedures above.
7. Repeat on the opposite side of machine.

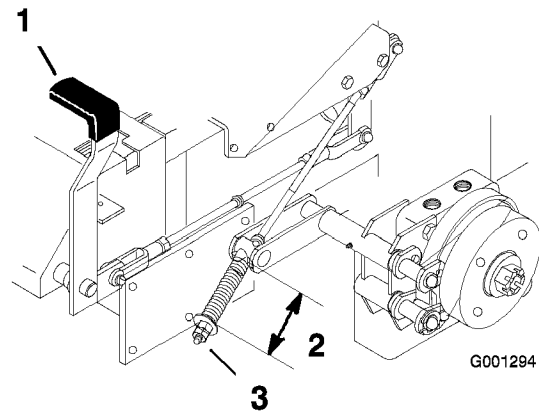

Figure 54

- | | |
|------------------------------|---------------------------------------|
| 1. Brake lever in engaged | 3. Adjusting nut and jam nut position |
| 2. Spring 2-1/2 inch (64 mm) | |

Belt Maintenance

Inspecting the Belts

Inspect all belts every 100 hours.

Check belts for cracks, frayed edges, burn marks or any other damage. Replace damaged belts.

Replacing the Mower Belt

Squealing when the belt is rotating, blades slipping when cutting grass, frayed belt edges, burn marks and cracks are signs of a worn mower belt. Replace the mower belt if any of these conditions are evident.

1. Disengage the PTO, move the motion control levers to the neutral locked position and set the parking brake.
2. Stop the engine, remove the key, and wait for all moving parts to stop before leaving the operating position.
3. Remove the belt covers (Figure 55).
4. Remove the spring and belt guide from the idler arm.

5. Remove the existing belt if needed.
6. Install the new belt around the mower pulleys and the gearbox pulley under the engine (Figure 56).
7. Install spring to the idler arm (Figure 56).
8. Install the belt guide on the spring loaded idler at a 45 degree angle as shown in Figure 56.
9. Install the belt covers by sliding the cover into the tab, install the bolts, and close the latches (Figure 55).

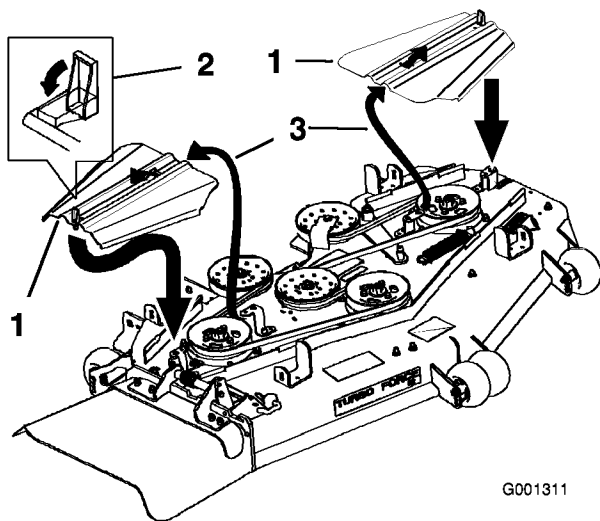

Figure 55

1. Belt cover
2. Latch
3. Insert slot into the tab

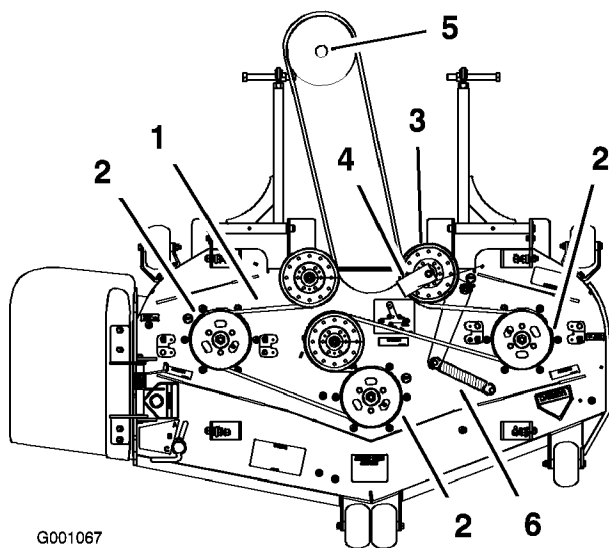

Figure 56

1. Mower belt
2. Mower spindle pulley
3. Mower idler pulley
4. Belt guide
5. Gearbox pulley
6. Spring

Replacing the PTO Drive Belt

Squealing when the belt is rotating, blades slipping when cutting grass, frayed belt edges, burn marks and cracks are signs of a worn PTO belt. Replace the mower belt if any of these conditions are evident.

1. Disengage the PTO, move the motion control levers to the neutral locked position and set the parking brake.
2. Stop the engine, remove the key, and wait for all moving parts to stop before leaving the operating position.
3. Loosen the front engine panel knobs and remove the panel (Figure 57).

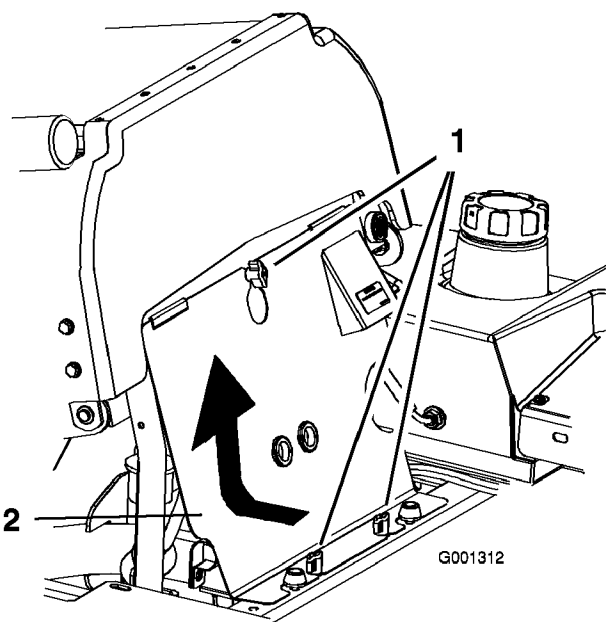

Figure 57

1. Knob
2. Front engine panel

4. Remove the spring from the idler arm (Figure 58).
5. Remove the clutch stop bracket.
6. Remove the old PTO drive belt.
7. Install the PTO drive belt around the clutch pulley and the gearbox pulley (Figure 58).
8. Install the clutch stop bracket.
9. Install the spring to the idler arm (Figure 58).

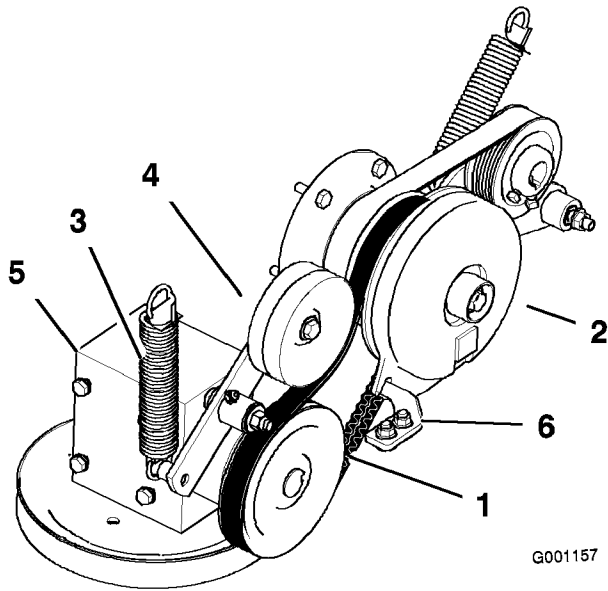

Figure 58

- | | |
|-------------------|-------------------------------|
| 1. PTO Drive belt | 4. Spring loaded idler pulley |
| 2. Clutch | 5. Gear box |
| 3. Spring | 6. Clutch stop bracket |

Replacing the Pump Drive Belt

Check pump drive belt for wear after every 50 hours of operation.

Note: Remove the PTO drive belt first if the pump drive belt needs to be replaced.

1. Tilt the seat forward and remove the front engine panel.
2. Remove the PTO drive belt.
3. Remove the spring from the idler arm (Figure 59).
4. Install the new belt around the engine and hydro pump pulley (Figure 59).
5. Install the PTO drive belt.
6. Install the spring to the idler arm (Figure 59).

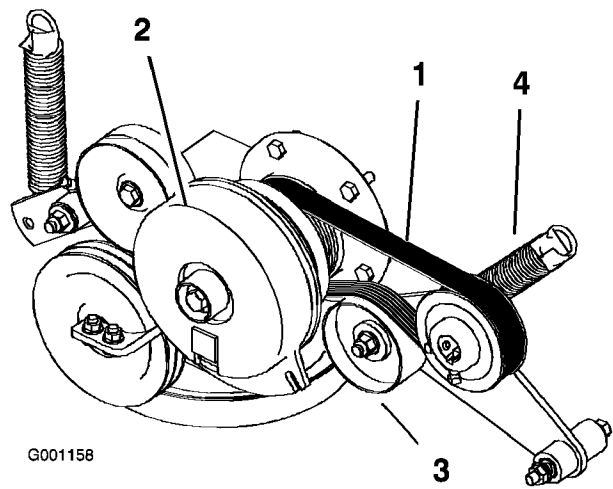

Figure 59

- | | |
|--------------------|-------------------------------|
| 1. Pump drive belt | 3. Spring loaded idler pulley |
| 2. Clutch | 4. Spring |

Replacing and Tensioning the Alternator Belt

Check the alternator belt for wear after every 50 hours of operation.

Replacing the Alternator Belt

1. Disengage the PTO, move the motion control levers to the neutral locked position and set the parking brake.
2. Stop the engine, remove the key, and wait for all moving parts to stop before leaving the operating position.
3. Remove the 4 bolts holding the oil cooler shield to the rear frame (Figure 60).
4. Remove the 3 bolts holding the engine straps to the side of the machine (Figure 60).

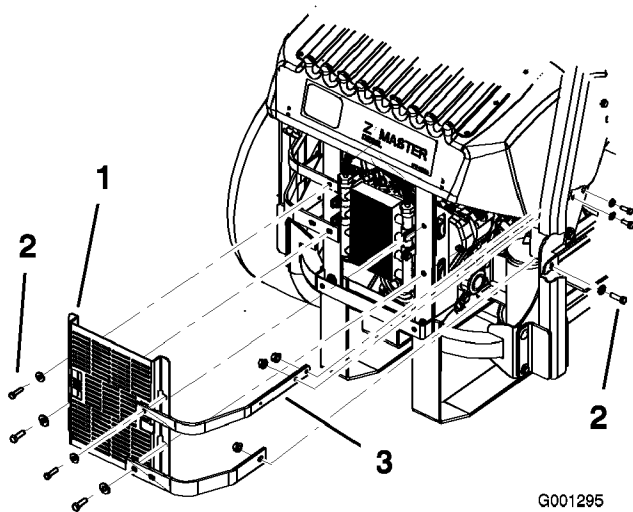

Figure 60

- | | |
|----------------------|------------------|
| 1. Oil cooler shield | 3. Engine straps |
| 2. Bolts | |

5. Remove the 4 bolts holding the oil cooler and position the oil cooler to the side (Figure 61).
6. Remove the 2 bolts holding the fan and fan plate to the machine (Figure 61).

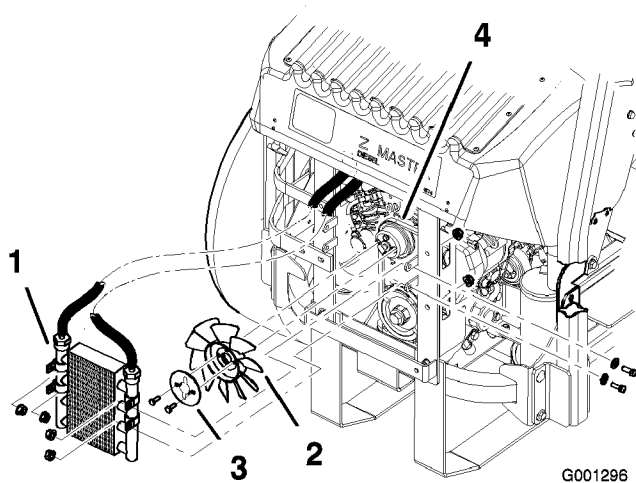

Figure 61

- | | |
|---------------|--------------------|
| 1. Oil cooler | 3. Fan plate |
| 2. Fan | 4. Alternator belt |

7. Loosen the bottom bolt and remove the upper bolt holding the alternator and cover (Figure 62).
8. Rotate the alternator cover to the side and remove the belt from the pulleys and alternator.
9. Install a new belt around the pulleys and the alternator (Figure 62).

10. Install the fan and fan plate to the machine with the 2 bolts previously removed (Figure 61).
11. Install the oil cooler with the 4 bolts previously removed (Figure 61).
12. Install the oil cooler shield and engine straps to the rear frame with the 4 bolts previously removed (Figure 60).
13. Install the engine straps to the side of the machine (Figure 60).
14. Tighten the bottom bolt and install the upper bolt holding the alternator and cover (Figure 62).

Tensioning the Alternator Belt

1. Place a handle between the alternator and cylinder block.
2. Adjust the alternator to the outside until there is 1/4 to 11/32 inch (7 to 9 mm) deflection in the belt between the engine and the alternator pulleys with 22.1 lbs of force (10 kgf) (Figure 62).
3. Tighten the alternator bolts.
4. Check the deflection in the belt again and adjust the belt if needed.
5. If the deflection is correct, tighten the bottom and upper bolt (Figure 62).

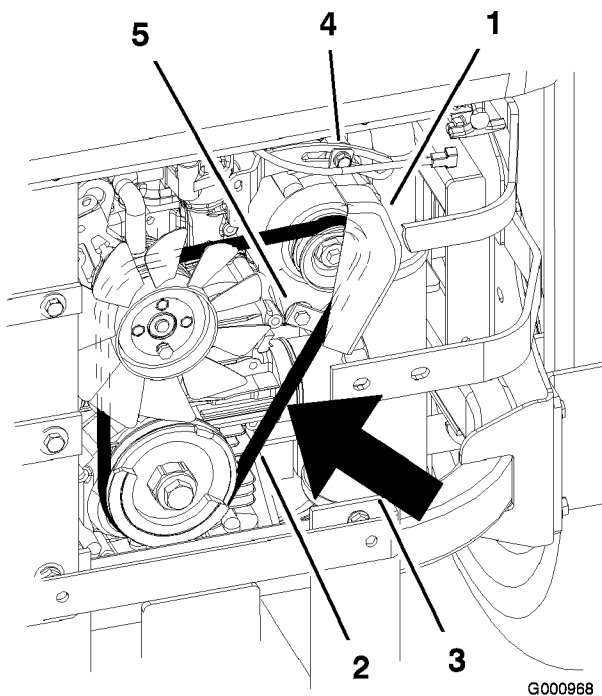

Figure 62

- | | |
|--|----------------|
| 1. Alternator | 4. Top bolt |
| 2. Alternator belt | 5. Bottom bolt |
| 3. Deflection, 1/4 to 11/32 inch (7 to 9 mm) with 22.1 lbs of force (10 kgf) | |

Controls System Maintenance

Adjusting the Control Handle Neutral Position

If motion control levers do not align, or move easily into the console notch, adjustment is required. Adjust each lever, spring and rod separately.

Note: Motion control levers must be installed correctly. See Installing the Motion Control Levers in the set up instructions.

1. Disengage the PTO, move the motion control levers to the neutral locked position and set the parking brake.
2. Stop the engine, remove the key, and wait for all moving parts to stop before leaving the operating position.
3. Unlatch the seat and tilt the seat forward.

4. Begin with either the left or right motion control lever.
5. Move the lever to the neutral position but not locked (Figure 63).
6. Pull the lever back until the clevis pin (on arm below pivot shaft) contacts the end of the slot (just beginning to put pressure on the spring) (Figure 63).
7. Check where the control lever is relative to notch in console (Figure 63). It should be centered allowing lever to pivot outward to the neutral lock position.

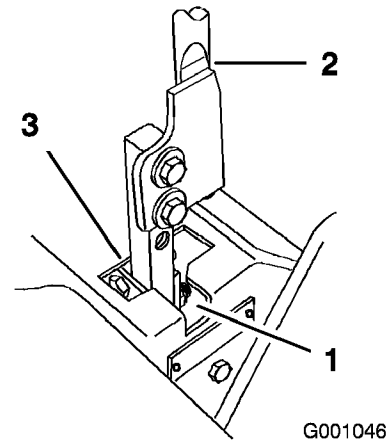

Figure 63

- | | |
|----------------------------|---------------------|
| 1. Neutral locked position | 3. Neutral position |
| 2. Control lever | |

8. If adjustment is needed, loosen the nut and jam nut against the yoke (Figure 64).
9. Apply slight rearward pressure on the motion control lever, turn the head of the adjustment bolt in the appropriate direction until the control lever is centered in the neutral lock position (Figure 64).

Note: Keeping rearward pressure on the lever will keep the pin at the end of the slot and allow the adjustment bolt to move the lever to the appropriate position.

10. Tighten the nut and jam nut (Figure 64).
11. Repeat for the opposite side of the machine.

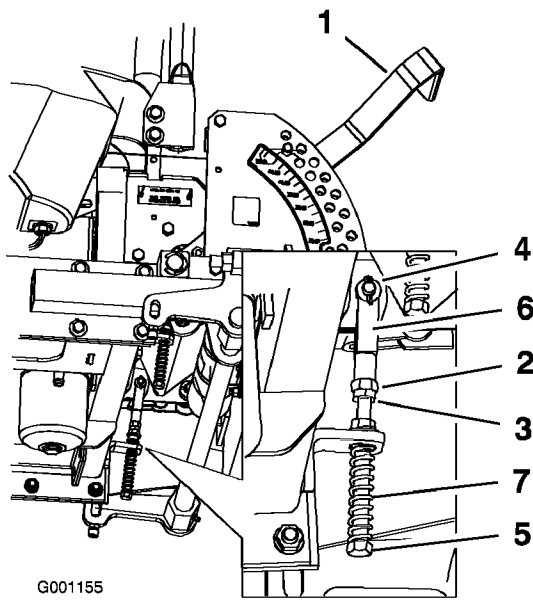

Figure 64

- | | |
|------------------------|--------------------|
| 1. Height-of-cut lever | 5. Adjustment bolt |
| 2. Nut against yoke | 6. Yoke |
| 3. Jam Nut | 7. Spring |
| 4. Clevis pin in slot | |

Hydraulic System Maintenance

Servicing the Hydraulic System

Checking the Hydraulic Fluid

Fluid Type: Mobil 1 15W-50 synthetic motor oil or equivalent synthetic oil.

Important: Use oil specified or equivalent. Other fluids could cause system damage.

Hydraulic System Oil Capacity: 132 ounces (3.9 l)

Check the hydraulic fluid level:

- Before the engine is first started.
- After the first 8 operating hours.
- After every 25 operating hours.

Note: There are two ways of checking the hydraulic oil. One is when the oil is warm and one is when the oil is cold. The baffle inside the tank has two levels depending if the oil is warm or cold.

1. Position the machine on a level surface and set the parking brake.

2. Clean the area around filler neck of hydraulic tank (Figure 65).
3. Remove the cap from the filler neck. Look inside to check if there is fluid in the reservoir (Figure 65).
4. If there is no fluid, add fluid to the reservoir until it reaches the cold level of the baffle.
5. Run the machine at low idle for 15 minutes to allow any air to purge out of the system and warm the fluid. Refer to Starting and Stopping the Engine in Operation, page 15.
6. Recheck the fluid level while the fluid is warm. The fluid should be between cold and hot.
7. If required, add fluid to the hydraulic tank.

Note: The fluid level should be to the top of the hot level of the baffle, when the fluid is hot (Figure 65).

8. Install cap on filler neck.

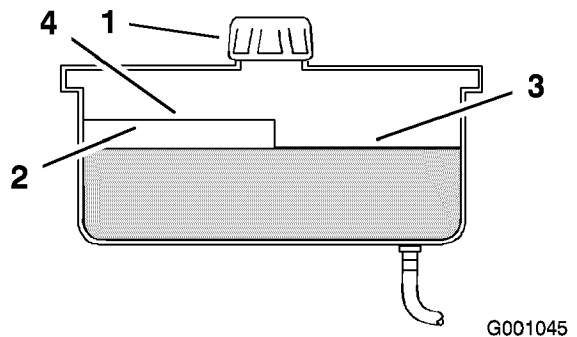

Figure 65

- | | |
|-----------|--------------------------|
| 1. Cap | 3. Cold fluid level-full |
| 2. Baffle | 4. Hot fluid level-full |



Hydraulic fluid escaping under pressure can penetrate skin and cause injury.

- If hydraulic fluid is injected into the skin it must be surgically removed within a few hours by a doctor familiar with this type of injury. Gangrene may result if this is not done.
- Keep body and hands away from pin hole leaks or nozzles that eject high pressure hydraulic fluid.
- Use cardboard or paper to find hydraulic leaks.
- Safely relieve all pressure in the hydraulic system before performing any work on the hydraulic system.
- Make sure all hydraulic fluid hoses and lines are in good condition and all hydraulic connections and fittings are tight before applying pressure to hydraulic system.

Replacing the Hydraulic Filter and Oil

Change the hydraulic filter and oil:

- After the first 25 operating hours.
- Change yearly after the first 25 operating hours.

Use summer filter above 32°F (0°C)

Use winter filter below 32°F (0°C)

1. Disengage the PTO, move the motion control levers to the neutral locked position and set the parking brake.
2. Stop the engine, remove the key, and wait for all moving parts to stop before leaving the operating position.

Important: Do not substitute automotive oil filter or severe hydraulic system damage may result.

3. Place drain pan under filter, remove the old filter and wipe the filter adapter gasket surface clean (Figure 66).

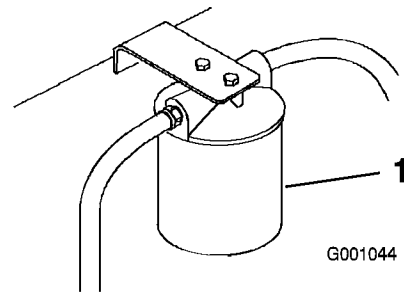

Figure 66

1. Hydraulic filter

4. Remove the righthand hydraulic line that comes into the adapter (Figure 67).
5. Allow the oil to drain out of the system into the drain pan.
6. Install the righthand hydraulic line to the adapter (Figure 67).

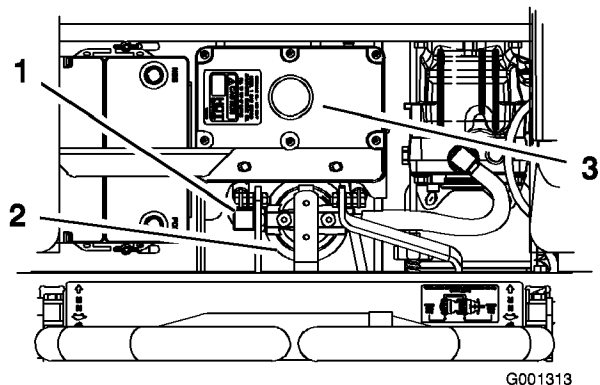

Figure 67

1. Righthand hydraulic line
2. Hydraulic filter
3. Hydraulic tank

7. Apply a thin coat to the rubber gasket on the replacement filter (Figure 68).
8. Install the replacement hydraulic filter onto the filter adapter. Do not tighten.
9. Fill the hydraulic tank with hydraulic fluid until the fluid overflows the filter and then turn the oil filter clockwise until the rubber gasket contacts the filter adapter, then tighten the filter an additional 1/2 turn (Figure 68).
10. Clean up any spilled fluid.
11. Add fluid to the cold level of the baffle in the hydraulic tank.
12. Start the engine and let it run for about two minutes to purge air from the system. Stop the engine and check for leaks. If one or

both wheels will not drive, refer to Bleeding Hydraulic System.

13. Recheck the fluid level while the fluid is warm. The fluid should be between cold and hot.
14. If required, add fluid to the hydraulic tank. Do not overfill.

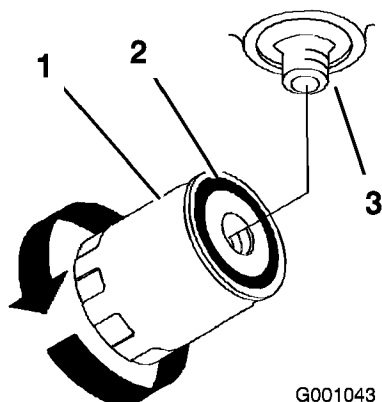

Figure 68

1. Hydraulic filter
2. Gasket
3. Adapter

Bleeding the Hydraulic System

The traction system is self bleeding, however, it may be necessary to bleed the system if fluid is changed or after work is performed on the system.

1. Raise rear of the machine so wheels are off the ground and support with jack stands.
2. Start the engine and run at low idle speed. Engage the lever and traction on one side and spin the wheel by hand.
3. When the wheel begins to spin on its own, keep it engaged until wheel drives smoothly. (minimum 2 minutes)
4. Check hydraulic fluid level and add as required to maintain proper level.
5. Repeat this procedure on the opposite wheel.

Checking the Hydraulic Hoses

After every 100 operating hours, check the hydraulic hoses for leaks, loose fittings, kinked lines, loose mounting supports, wear, weather and chemical deterioration. Make necessary repairs before operating.

Note: Keep areas around the hydraulic system clean from grass and debris build up.



Hydraulic fluid escaping under pressure can penetrate skin and cause injury.

- If hydraulic fluid is injected into the skin it must be surgically removed within a few hours by a doctor familiar with this type of injury. Gangrene may result if this is not done.
- Keep body and hands away from pin hole leaks or nozzles that eject high pressure hydraulic fluid.
- Use cardboard or paper to find hydraulic leaks.
- Safely relieve all pressure in the hydraulic system before performing any work on the hydraulic system.
- Make sure all hydraulic fluid hoses and lines are in good condition and all hydraulic connections and fittings are tight before applying pressure to hydraulic system.

Setting the Hydraulic Pump Neutral Position

Note: Adjust the handle neutral first. That needs to be correct before the following adjustment can be made.

This adjustment must be made with drive wheels turning.



Mechanical or hydraulic jacks may fail to support machine and cause a serious injury.

- Use jack stand when supporting machine.
- Do not use hydraulic jacks.



Engine must be running so motion control adjustment can be performed. Contact with moving parts or hot surfaces may cause personal injury.

Keep hands, feet, face, clothing and other body parts away from rotating parts, muffler and other hot surfaces.

1. Raise the frame and block up the machine so drive wheels can rotate freely.
2. Disconnect the electrical connector from the seat safety switch. Temporarily install a jumper wire across terminals in the wiring harness connector.
3. Unlatch the seat and slide seat forward.
4. Disconnect the seat rod and tilt the seat fully forward.

Setting the Right-hand Hydraulic Pump Neutral Position

1. Start the engine, open the throttle 1/2 way and release parking brake. Refer to Starting and Stopping the Engine in Operation, page 15.

Note: The motion control lever must be in neutral while making any adjustments.

2. Adjust the pump rod length by rotating the knob, in the appropriate direction, until the wheel is still or slightly creeping in reverse (Figure 69).
3. Move the motion control lever forward and reverse, then back to neutral. The wheel must stop turning or slightly creep in reverse.
4. Open the throttle to fast. Make sure wheel remains stopped or slightly creeps in reverse, adjust if necessary.

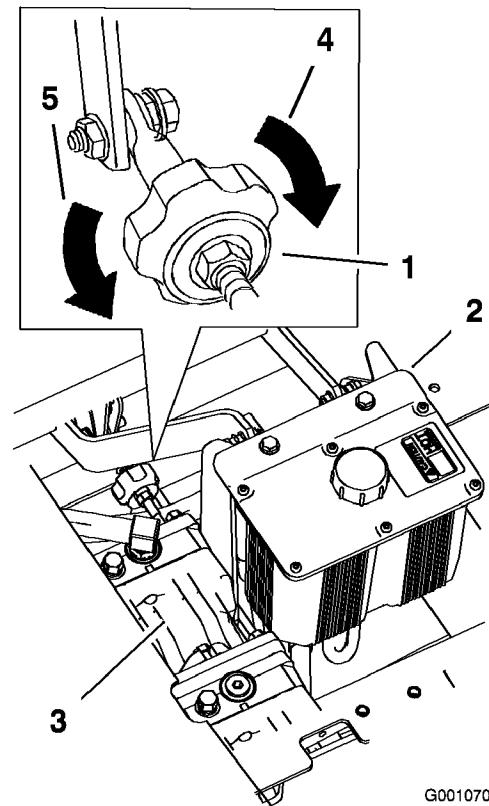

G001070

Figure 69

1. Tracking knob
2. Hydraulic tank
3. Hydraulic pumps
4. Turn this way to track right
5. Turn this way to track left

Setting the Left-hand Hydraulic Pump Neutral Position

1. Loosen the locknuts at the ball joints on the pump control rod (Figure 70).
2. Start the engine, open throttle 1/2 way and release parking brake. Refer to Starting and Stopping the Engine in Operation, page 15.

Note: The motion control lever must be in neutral while making any adjustments.

Note: The front nut on the pump rod has left-hand threads.

3. Adjust the pump rod length by rotating double nuts on rod, in the appropriate direction, until wheel is still or slightly creeps in reverse (Figure 70).
4. Move the motion control lever forward and reverse, then back to neutral. The wheel must stop turning or slightly creep in reverse.
5. Open the throttle to fast. Make sure the wheel remains stopped or slightly creeps in reverse, adjust if necessary.

6. Tighten the locknuts at the ball joints (Figure 70).

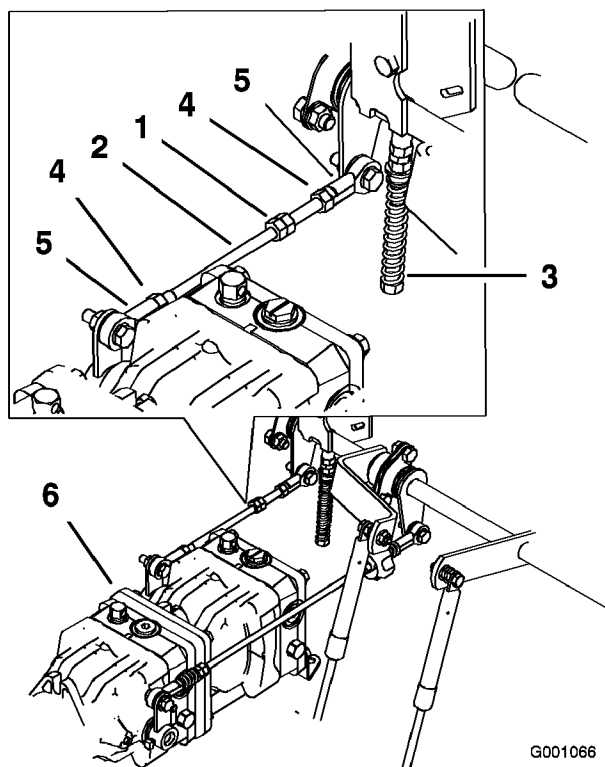

Figure 70

- | | |
|--------------------|---------------|
| 1. Double nuts | 4. Locknut |
| 2. Pump rod | 5. Ball joint |
| 3. Adjustment bolt | 6. Pumps |

Electrical system will not perform proper safety shut off with jumper wire installed.

- Remove jumper wire from wire harness connector and plug connector into seat switch when adjustment is completed.
- Never operate this unit with jumper installed and seat switch bypassed.

7. After both pump neutrals are set, shut off the machine.
8. Remove the jumper wire from the wire harness connector and plug the connector into the seat switch.
9. Install the seat rod and lower the seat into position.
10. Remove the jack stands.

Mower Deck Maintenance

Leveling the Mower at Three Positions

Important: There are only three measuring positions needed to level the mower.

Setting Up the Machine

1. Position mower on a flat surface.
2. Disengage the PTO, move the motion control levers to the neutral locked position and set the parking brake.
3. Stop the engine, remove the key, and wait for all moving parts to stop before leaving the operating position.
4. Check tire pressure of all four tires. If needed, adjust to 13 psi (90 kPa)
5. Lower the mower to the 3 inch (76 mm) height-of-cut position.
6. Inspect the four chains. The chains need to have tension.
 - If one rear chain is loose, lower (loosen) the front support arm on the same side. Refer to Adjusting the Front-to-Rear Mower Pitch.
 - If one front chain is loose, raise (tighten) the front support arm for that chain. Refer to Adjusting the Front-to-Rear Mower Pitch.

Leveling the Mower Side-to-Side

1. Position the right blade front-to-rear (Figure 71).
2. Measure the right blade at the **B** location, from a level surface to the cutting edge of the blade tip (Figure 71).
3. Record this measurement. This measurement needs to be 3-1/8 to 3-1/4 inches.
4. Position the left blade front-to-rear (Figure 71).
5. Measure the left blade at the **C** location (Figure 71), from a level surface to the cutting edge of the blade tip .
6. Record this measurement. This measurement needs to be 3-1/8 to 3-1/4 inches.

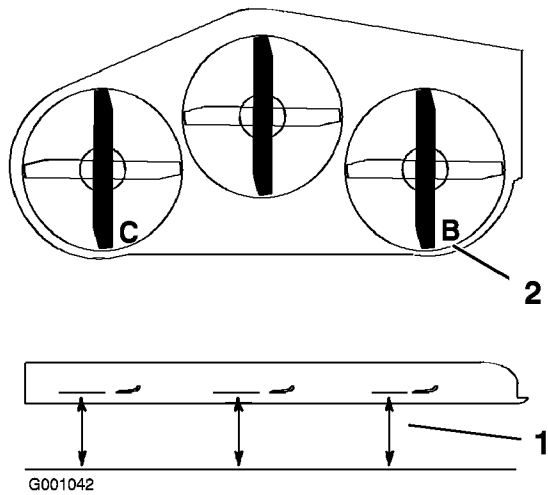

Figure 71

1. Measure here from blade
2. Measure at B and C to hard surface

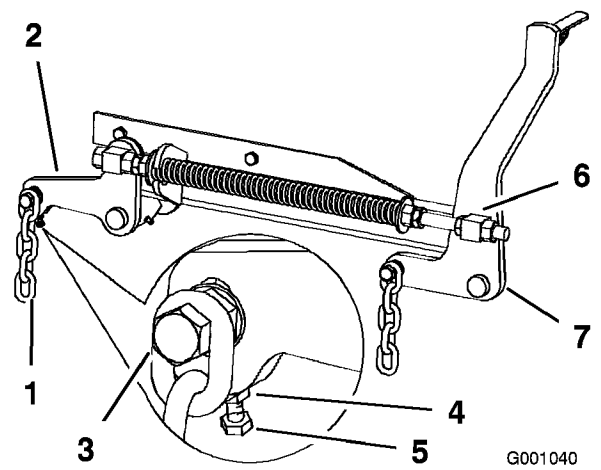

Figure 72

1. Rear chain
2. Rear support arm
3. Bolt
4. Jam Nut
5. Adjustment bolt
6. Front swivel
7. Front support arm

7. If the measurements at positions **B** or **C** are not correct, loosen the bolt attaching the rear chain to the rear support arm (Figure 72).

8. Loosen the jam nut under the rear support arm and adjust the adjustment bolt to get a measurement of 3-1/8 to 3-1/4 inches (Figure 72).

Note: It is recommended that both sides of the mower are adjusted the same distance.

9. Tighten the jam nut under the rear support arm and tighten the bolt securing the chain to the rear support arm.

10. Adjust the opposite side if needed.

Adjusting the Front-to-Rear Mower Pitch

1. Position the right blade front-to-rear (Figure 73).
2. Measure the right blade at the **A** location, from a level surface to the cutting edge of the blade tip (Figure 73).

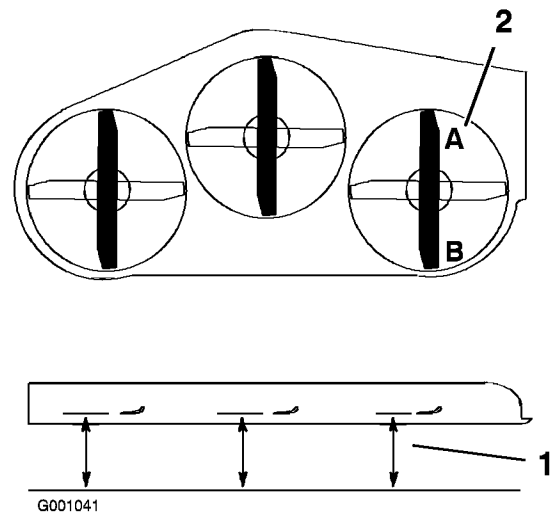

Figure 73

1. Measure here from blade
2. Measure at A and B to hard surface

3. Record this measurement.

4. Measure the right blade at the **B** location, from a level surface to the cutting edge of the blade tip (Figure 73).
5. Record this measurement.
6. The mower blade should be a 1/4 to 3/8 inch (6 to 10 mm) lower at position **A** than at position **B** (Figure 73). If it is not correct, proceed to the following steps.

Note: Both of the front swivels need to be adjusted the same amount to maintain equal chain tension.

7. Loosen the front swivel jam nuts, at the front of the right and left swivels, approximately a 1/2 inch (13 mm) (Figure 72).
8. Adjust the lift nuts on both the left and the right side of the machine to achieve 1/4 to 3/8 inch (6 to 10 mm) lower in front at **A** than in the rear at **B** (Figure 72).
9. Tighten both swivel jam nuts against the front swivel to lock the height.
10. Check to make sure there is equal tension on the chains and adjust again if needed.

Adjusting the Compression Spring

1. Raise the mower lift lever to the transport position.
2. Check the distance between the two large washers, it needs to be 11-1/8 inches (28.2 cm) for 52 inch mower decks and 10-1/2 inches (26.7 cm) for 60 inch mower decks (Figure 74).
3. Adjust this distance, by loosening the spring jam nut and turning the nut in front of each spring (Figure 74). Turning the nut clockwise will shorten the spring; counter-clockwise will lengthen the spring.
4. Lock the nut into position by tightening the spring jam nut (Figure 74).

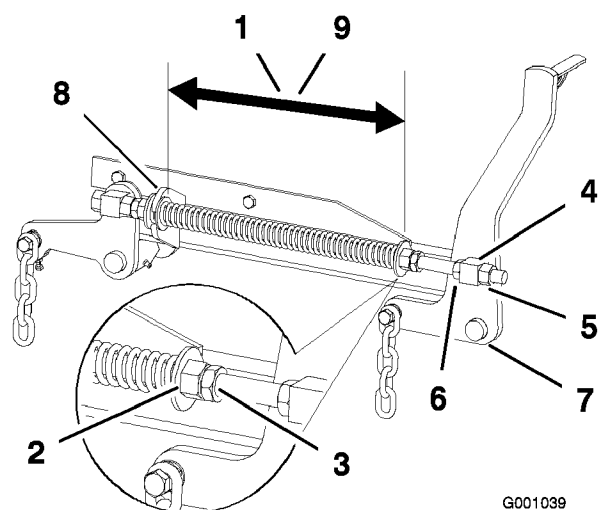

Figure 74

- | | |
|--|--|
| 1. 11-1/8 inch (28.2 cm) between the large washers for 52 inch mower decks | 6. Lift nut |
| 2. Front nut | 7. Front support arm |
| 3. Spring jam nut | 8. Large washer |
| 4. Front swivel | 9. 10-1/2 inch (26.7 cm) between the large washers for 60 inch mower decks |
| 5. Swivel jam nut | |

Servicing the Cutting Blades

Maintain sharp blades throughout the cutting season because sharp blades cut cleanly without tearing or shredding the grass blades. Tearing and shredding turns grass brown at the edges, which slows growth and increases the chance of disease.

Check the cutter blades daily for sharpness, and for any wear or damage. File down any nicks and sharpen the blades as necessary. If a blade is damaged or worn, replace it immediately with a genuine Toro replacement blade. For convenient sharpening and replacement, you may want to keep extra blades on hand.



A worn or damaged blade can break, and a piece of the blade could be thrown into the operator's or bystander's area, resulting in serious personal injury or death.

- Inspect the blade periodically for wear or damage.
- Replace a worn or damaged blade.

Inspect and check the blades every 8 hours.

Before Inspecting or Servicing the Blades

Park the machine on a level surface, disengage the blade control (PTO), and set the parking brake. Turn the ignition key to Off. Remove the key.

Inspecting the Blades

1. Inspect the cutting edges (Figure 75). If the edges are not sharp or have nicks, remove and sharpen the blades. Refer to Sharpening the Blades.
2. Inspect the blades, especially the curved area (Figure 75). If you notice any damage, wear, or a slot forming in this area (Figure 75), immediately install a new blade.

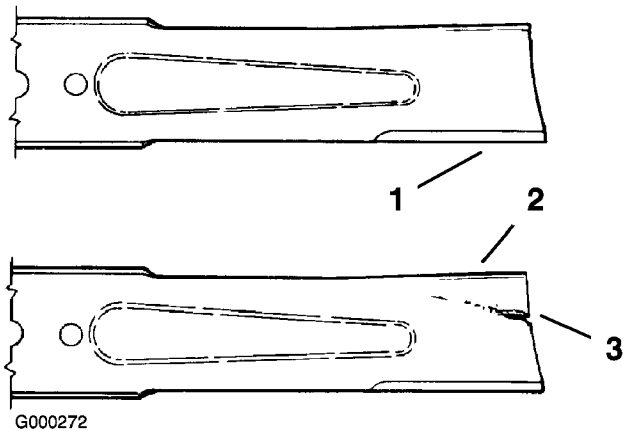

Figure 75

1. Cutting Edge
2. Curved Area
3. Wear/slot Forming

Checking for Bent Blades

1. Disengage the PTO, move the motion control levers to the neutral locked position and set the parking brake.
2. Stop the engine, remove the key, and wait for all moving parts to stop before leaving the operating position.
3. Rotate the blades until the ends face forward and backward (Figure 76). Measure from a level surface to the cutting edge, position **A**, of the blades (Figure 76). Note this dimension.

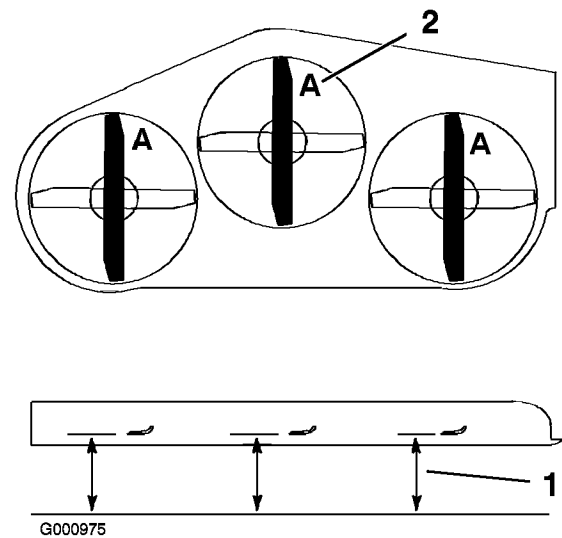

Figure 76

1. Measure here from blade to hard surface
2. Position A
3. Measure from a level surface to the cutting edge of the blades at the same position as in step 3 above. The difference between the dimensions obtained in steps 3 and 4 must not exceed 1/8 inch (3 mm). If this dimension exceeds 1/8 inch (3 mm), the blade is bent and must be replaced; refer to Removing the Blades and Installing the Blades.
4. Rotate the opposite ends of the blades forward.
5. Measure from a level surface to the cutting edge of the blades at the same position as in step 3 above. The difference between the dimensions obtained in steps 3 and 4 must not exceed 1/8 inch (3 mm). If this dimension exceeds 1/8 inch (3 mm), the blade is bent and must be replaced; refer to Removing the Blades and Installing the Blades.



A blade that is bent or damaged could break apart and could seriously injure or kill you or bystanders.

- Always replace bent or damaged blade with a new blade.
- Never file or create sharp notches in the edges or surfaces of blade.

Removing the Blades

Blades must be replaced if a solid object is hit, if the blade is out of balance or is bent. To ensure optimum performance and continued safety conformance of the machine, use genuine TORO replacement blades. Replacement blades made by other manufacturers may result in non-conformance with safety standards.



Contact with a sharp blade can cause serious injury.

Wear gloves or wrap sharp edges of the blade with a rag.

1. Hold the blade end using a rag or thickly-padded glove.
2. Remove the blade bolt, spring disk and blade from the spindle shaft (Figure 79).

Sharpening the Blades



When sharpening blade, pieces of blade could be thrown and cause serious injury.

Wear proper eye protection when sharpening blade.

1. Use a file to sharpen the cutting edge at both ends of the blade (Figure 77). Maintain the original angle. The blade retains its balance if the same amount of material is removed from both cutting edges.

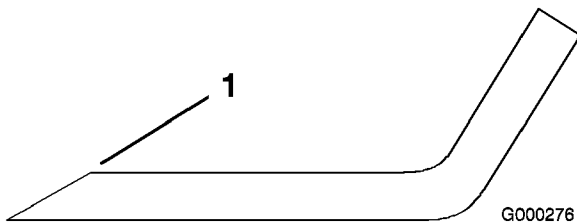

Figure 77

1. Sharpen at original angle

2. Check the balance of the blade by putting it on a blade balancer (Figure 78). If the blade stays in a horizontal position, the blade is balanced and can be used. If the blade is not balanced, file some metal off the end of the sail area only (Figure 79). Repeat this procedure until the blade is balanced.

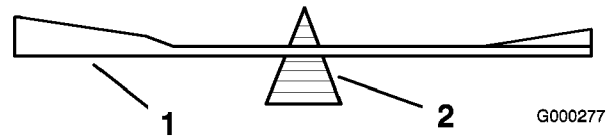

Figure 78

1. Blade
2. Balancer

Installing the Blades

1. Install the blade onto the spindle shaft (Figure 79).

Important: The curved part of the blade must be pointing upward toward the inside of the mower to ensure proper cutting.

2. Install the spring disk and blade bolt. The spring disk cone must be installed toward the bolt head (Figure 79). Torque the blade bolt to 85-110 ft-lb (115-150 N•m).

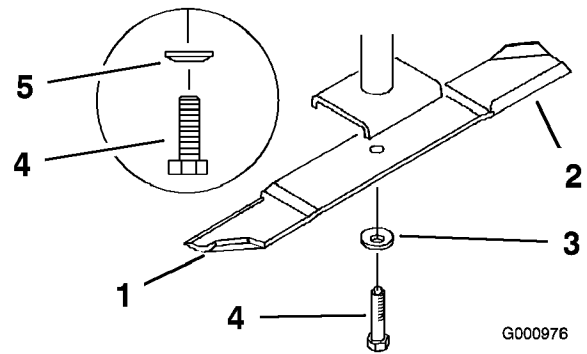

Figure 79

1. Sail Area of Blade
2. Blade
3. Spring Disk
4. Blade Bolt
5. Cone Towards Bolt Head

Replacing the Grass Deflector



An uncovered discharge opening could allow the lawn mower to throw objects in the operator's or bystander's direction and result in serious injury. Also, contact with the blade could occur.

- Never operate the lawn mower unless you install a cover plate, a mulch plate, or a grass chute and catcher.
- Make sure the grass deflector is in the down position.

1. Remove the locknut, bolt, spring and spacer holding the deflector to the pivot brackets (Figure 80). Remove the damaged or worn grass deflector.
2. Place the spacer and spring onto grass deflector. Place the **L** end of spring behind deck edge.

Note: Make sure the L end of the spring is installed behind the deck edge before installing the bolt as shown in Figure 80.

3. Install the bolt and nut. Place the **J** hook end of the spring around the grass deflector (Figure 80).

Important: The grass deflector must be able to lower down into position. Lift the deflector up to test that it lowers into the full down position.

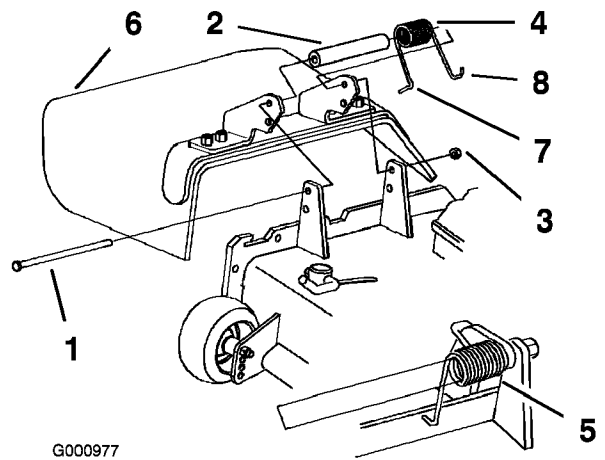

Figure 80

- | | |
|------------|---|
| 1. Bolt | 5. Spring installed |
| 2. Spacer | 6. Grass Deflector |
| 3. Locknut | 7. L end of spring, place behind deck edge before installing bolt |
| 4. Spring | 8. J hook end of spring |

Cleaning

Cleaning Under the Mower

Remove the grass buildup under the mower daily.

1. Disengage the PTO, move the motion control levers to the neutral locked position and set the parking brake.
2. Stop the engine, remove the key, and wait for all moving parts to stop before leaving the operating position.
3. Raise the mower to the transport position.

Waste Disposal

Engine oil, batteries, hydraulic oil, and engine coolant are pollutants to the environment. Dispose of these according to your state and local regulations.

Storage

Cleaning and Storage

1. Disengage the power take off (PTO), set the parking brake, and turn the ignition key to Off. Remove the key.
2. Remove grass clippings, dirt, and grime from the external parts of the entire machine, especially the engine and hydraulic system. Clean dirt and chaff from the outside of the engine cylinder head fins and blower housing.

Important: You can wash the machine with mild detergent and water. Do not pressure wash the machine. Avoid excessive use of water, especially near the control panel, engine, hydraulic pumps, and motors.

3. Check the brake; refer to Servicing the Brake in Brake Maintenance, page 44.
4. Service the air cleaner; refer to Servicing the Air Cleaner in Engine Maintenance, page 32.
5. Grease the machine; refer to Greasing and Lubrication in Lubrication, page 31.
6. Change the crankcase oil; refer to Servicing the Engine Oil in Engine Maintenance, page 32.
7. Check the tire pressure; refer to Checking the Tire Pressure in Drive System Maintenance, page 40.
8. Change the hydraulic filter; refer to Servicing the Hydraulic System in Hydraulic System Maintenance, page 49.
9. Charge the battery; refer to Servicing the Battery in Electrical System Maintenance, page 37.
10. Scrape any heavy buildup of grass and dirt from the underside of the mower, then wash the mower with a garden hose.

Note: Run the machine with the PTO engaged and the engine at high idle for 2 to 5 minutes after washing.

11. Check the condition of the blades; refer to Servicing the Cutting Blades in Mower Deck Maintenance, page 53.
12. Prepare the machine for storage when non-use occurs over 30 days. Prepare the machine for storage as follows:

- A. Add a petroleum based stabilizer/conditioner to fuel in the tank. Follow mixing instructions from the stabilizer manufacturer. Do not use an alcohol based stabilizer (ethanol or methanol).

Note: A fuel stabilizer/conditioner is most effective when mixed with fresh fuel and used at all times.

- B. Run the engine to distribute conditioned fuel through the fuel system (5 minutes).
- C. Stop the engine, allow it to cool, and drain the fuel tank; refer to Servicing the Fuel Tank in Fuel System Maintenance, page 36.
- D. Restart the engine and run it until it stops.
- E. Dispose of fuel properly. Recycle as per local codes.

Important: Do not store stabilizer/conditioned fuel over 90 days.

13. Check and tighten all bolts, nuts, and screws. Repair or replace any part that is damaged.
14. Paint all scratched or bare metal surfaces. Paint is available from your Authorized Service Dealer.
15. Store the machine in a clean, dry garage or storage area. Remove the key from the ignition switch and keep it out of reach of children or other unauthorized users. Cover the machine to protect it and keep it clean.

Troubleshooting

Problem	Possible Cause	Corrective Action
Starter does not crank	<ol style="list-style-type: none"> 1. Blade control (PTO) is engaged. 2. Parking brake is not on. 3. Operator is not seated. 4. Battery is dead. 5. Electrical connections are corroded or loose. 6. Fuse is blown. 7. Relay or switch is defective. 	<ol style="list-style-type: none"> 1. Move blade contro (PTO) to disengaged. 2. Set the parking brake. 3. Sit on the seat. 4. Charge the battery. 5. Check the electrical connections for good contact. 6. Replace fuse. 7. Contact an Authorized Service Dealer.
Engine will not start, starts hard, or fails to keep running.	<ol style="list-style-type: none"> 1. Fuel tank is empty. 2. Air cleaner is dirty. 3. Dirt in the fuel filter. 4. Dirt, water, or stale fuel is in the fuel system. 	<ol style="list-style-type: none"> 1. Fill fuel tank with fuel. 2. Clean or replace the air cleaner element. 3. Replace the fuel filter. 4. Contact an Authorized Service Dealer.
Engine loses power.	<ol style="list-style-type: none"> 1. Engine load is excessive. 2. Air cleaner is dirty. 3. Oil level in the crankcase is low. 4. Cooling fins and air passages above the engine are plugged. 5. Vent hole in the fuel cap is plugged. 6. Dirt in the fuel filter. 7. Dirt, water, or stale fuel is in the fuel system. 	<ol style="list-style-type: none"> 1. Reduce the ground speed. 2. Clean the air cleaner element. 3. Add oil to the crankcase. 4. Remove the obstruction from the cooling fins and air passages. 5. Clean or replace the fuel cap. 6. Replace the fuel filter. 7. Contact an Authorized Service Dealer.
Engine overheats.	<ol style="list-style-type: none"> 1. Engine load is excessive. 2. Oil level in the crankcase is low. 3. Cooling fins and air passages above the engine are plugged. 	<ol style="list-style-type: none"> 1. Reduce the ground speed. 2. Add oil to the crankcase. 3. Remove the obstruction from the cooling fins and air passages.

Problem	Possible Cause	Corrective Action
Machine does not drive.	<ol style="list-style-type: none"> 1. By pass valve is not closed tight. 2. Drive or pump belt is worn, loose or broken. 3. Drive or pump belt is off a pulley. 4. Broken or missing idler spring. 5. Hydraulic fluid level is low or too hot. 	<ol style="list-style-type: none"> 1. Tighten the by pass valve. 2. Change the belt. 3. Change the belt. 4. Replace the spring. 5. Add hydraulic fluid to reservoir or let it cool down.
Abnormal vibration.	<ol style="list-style-type: none"> 1. Cutting blade(s) is/are bent or unbalanced. 2. Blade mounting bolt is loose. 3. Engine mounting bolts are loose. 4. Loose engine pulley, idler pulley, or blade pulley. 5. Engine pulley is damaged. 6. Blade spindle is bent. 7. Motor mount is loose or worn. 	<ol style="list-style-type: none"> 1. Install new cutting blade(s). 2. Tighten the blade mounting bolt. 3. Tighten the engine mounting bolts. 4. Tighten the appropriate pulley. 5. Contact an Authorized Service Dealer. 6. Contact an Authorized Service Dealer. 7. Contact an Authorized Service Dealer.
Uneven cutting height.	<ol style="list-style-type: none"> 1. Blade(s) not sharp. 2. Cutting blade(s) is/are bent. 3. Mower is not level. 4. Underside of mower is dirty. 5. Tire pressure is not correct. 6. Blade spindle bent. 	<ol style="list-style-type: none"> 1. Sharpen the blade(s). 2. Install new cutting blade(s). 3. Level mower from side-to-side and front-to-rear. 4. Clean the underside of the mower. 5. Adjust the tire pressure. 6. Contact an Authorized Service Dealer.

Problem	Possible Cause	Corrective Action
Blades do not rotate.	<ol style="list-style-type: none"> 1. Drive belt is worn, loose or broken. 2. Drive belt is off pulley. 3. Deck belt is worn, loose or broken. 4. Deck belt is off pulley. 5. Broken or missing idler spring. 	<ol style="list-style-type: none"> 1. Check the belt tension. 2. Install drive belt and check adjusting shafts and belt guides for correct position. 3. Install new deck belt. 4. Install deck pulley and check the idler pulley, idler arm and spring for correct position and function. 5. Replace the spring.

Wire Diagram (Rev. A)

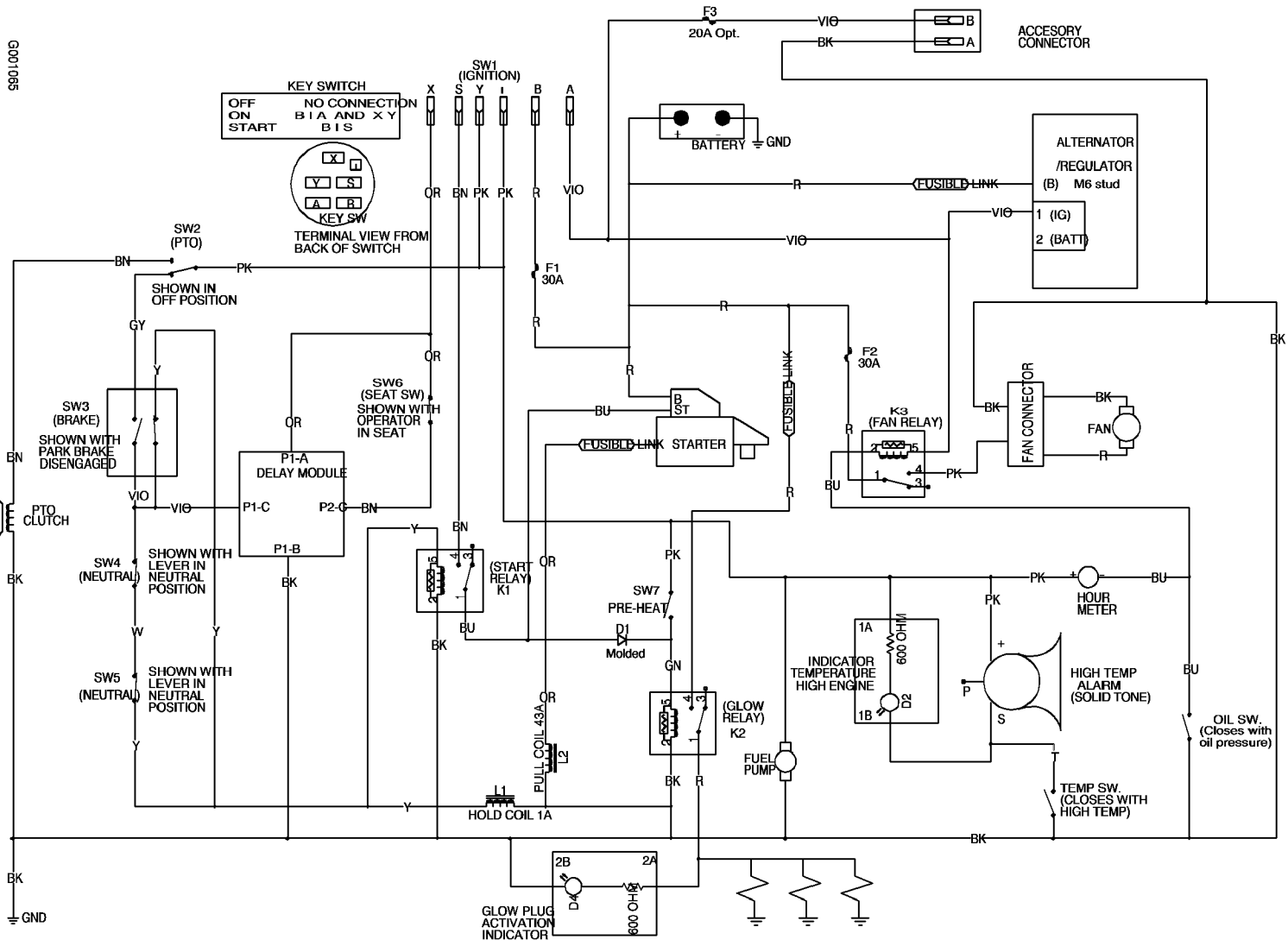

G0010695



LCE

The Toro Total Coverage Guarantee

A Limited Warranty

Conditions and Products Covered

The Toro Company and its affiliate, Toro Warranty Company, pursuant to an agreement between them, jointly promise to repair the listed Toro Products if defective in materials or workmanship. The following time periods apply from the date of purchase:

Products	Warranty Period
All Products	1 year
All Spindles	2 years (parts and labor; third year, parts only)
Engines/Hydraulic Systems* on the following: Outfront and Mid-Mount Z's ProLine Mid-Size Mowers Groundsmaster[Symbol_registersans] Riding Mowers Backpack Blowers	2 years
Deck Shells (32"-72") on the following: ProLine Mid-Size Mowers Mid-Mount Z's	2 years
Electric Clutch on 500 Series Mid-Mount Z's	2 years

This warranty includes the cost of parts and labor, but you must pay transportation costs.

This warranty applies to:

- Outfront and Mid-Mount Z's
- ProLine Mid-Size Mowers
- Groundsmaster Riding Mowers
- Turf Maintenance Equipment
- Debris Management Equipment

Some engines used on Toro LCE Products are warranted by the engine manufacturer.

Instructions for Obtaining Warranty Service

If you think that your Toro Product contains a defect in materials or workmanship, follow this procedure:

1. Contact any Toro Authorized or Master Service Dealer to arrange service at their dealership. To locate a dealer convenient to you, access our website at www.Toro.com. You may also call our Toro Customer Care Department toll free at 888-577-7466 (U.S. Customers) or 877-484-9255 (Canada customers).
2. Bring the product and your proof of purchase (sales receipt) to the Service Dealer.

If for any reason you are dissatisfied with the Service Dealer's analysis or with the assistance provided, contact us at:

Countries Other than the United States or Canada

Customers who have purchased Toro products exported from the United States or Canada should contact their Toro Distributor (Dealer) to obtain guarantee policies for your country, province, or state. If for any reason you are dissatisfied with your Distributor's service or have difficulty obtaining guarantee information, contact the Toro importer. If all other remedies fail, you may contact us at Toro Warranty Company.

Owner Responsibilities

You must maintain your Toro Product by following the maintenance procedures described in the operator's manual. Such routine maintenance, whether performed by a dealer or by you, is at your expense.

Items and Conditions Not Covered

There is no other express warranty except for special emission system coverage on some products. This express warranty does not cover the following:

- Cost of regular maintenance service or parts, such as filters, fuel, lubricants, tune-up parts, blade sharpening, brake and clutch adjustments.
- Any product or part which has been altered or misused or required replacement or repair due to normal wear, accidents, or lack of proper maintenance.
- Repairs necessary due to improper fuel, contaminants in the fuel system, or failure to properly prepare the fuel system prior to any period of non-use over three months.
- Pickup and delivery charges.

All repairs covered by this warranty must be performed by an Authorized Toro Service Dealer using Toro approved replacement parts.

General Conditions

Repair by an Authorized Toro Service Dealer is your sole remedy under this warranty.

Neither The Toro Company nor Toro Warranty Company is liable for indirect, incidental or consequential damages in connection with the use of the Toro Products covered by this warranty, including any cost or expense of providing substitute equipment or service during reasonable periods of malfunction or non-use pending completion of repairs under this warranty.

Some states do not allow exclusions of incidental or consequential damages, or limitations on how long an implied warranty lasts, so the above exclusions and limitations may not apply to you.

All implied warranties of merchantability (that the product is fit for ordinary use) and fitness for use (that the product is fit for a particular purpose) are limited to the duration of the express warranty.

This warranty gives you specific legal rights, and you may also have other rights which vary from state to state.

LCB Customer Service Department
Toro Warranty Company
8111 Lyndale Avenue South
Bloomington, MN 55420-1196