



Installation Instructions

NOTE: Read the entire instruction manual before starting the installation.

TABLE OF CONTENTS

	PAGE
SAFETY CONSIDERATIONS	2
INTRODUCTION	2
RECEIVING AND INSTALLATION	2-7
Check Equipment	2
Identify Unit	2
Inspect Shipment	2
Provide Unit Support	2
Slab Mount	2
Ground Mount	2
Provide Clearances	2
Place Unit	2
Select and Install Ductwork	2
Configuring Units for Downflow (Vertical) Discharge	3
Connect Condensate Drain	3
Install Electrical Connections	6
High-Voltage Connections	6
Routing Power Leads Into Unit	6
Connecting Ground Lead to Unit Ground	6
Routing Control Power Wires	6
Accessory Electric Heat Wiring	6
PRE-START-UP	7
START-UP	8-17
Check for Refrigerant Leaks	8
Start-Up Cooling and Make Adjustments	8
Checking Cooling and Heating Control Operation	8
Refrigerant Charge	8
No Charge	8
Low Charge Cooling	8
Heating Mode Charge	8
Indoor Airflow and Airflow Adjustments	9
Unit Controls	9
High-Pressure Relief Valve	9
Loss-of-Charge Switch	9
Compressor Overload	10
Compressor Rotation	10
Sequence of Operation	10
Fan Operation	10

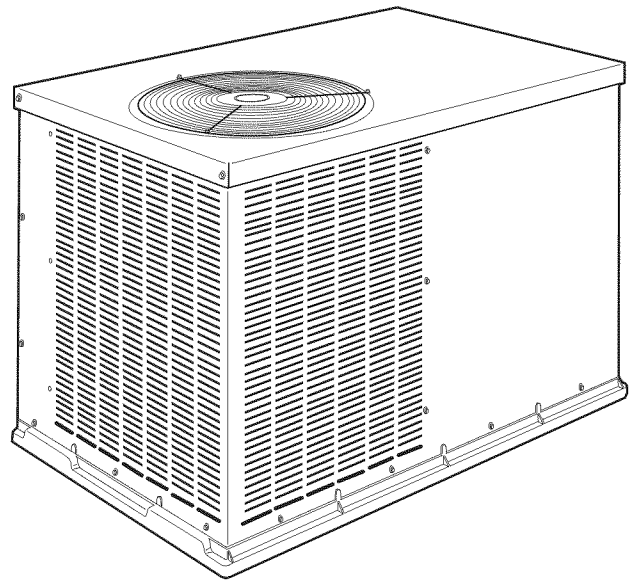

A05194

Fig. 1 - Unit PH3Z

Cooling Operation	10, 17
Heating Operation	17
Continuous Fan	17
Defrost	17
Electric Resistance Heating	17
MAINTENANCE	17-20
Air Filter	18
Unit Top Removal	18
Indoor Blower and Motor	18
Outdoor Coil, Indoor Coil, and Condensate Drain Pan	19
Outdoor Fan	19
Electrical Controls and Wiring	19
Refrigerant Circuit	20
Indoor Airflow	20
Metering Devices	20
Liquid Line Strainers	20
High Flow Valves	20
TROUBLESHOOTING	20
START-UP CHECKLIST	20

SAFETY CONSIDERATIONS

Installation and servicing of this equipment can be hazardous due to mechanical and electrical components. Only trained and qualified personnel should install, repair, or service this equipment. Untrained personnel can perform basic maintenance functions such as cleaning and replacing air filters. All other operations must be performed by trained service personnel. When working on this equipment, observe precautions in the literature, on tags, and on labels attached to or shipped with the unit and other safety precautions that may apply.

Follow all safety codes. Installation must be in compliance with local and national building codes. Wear safety glasses, protective clothing, and work gloves. Have fire extinguisher available. Read these instructions thoroughly and follow all warnings or cautions included in literature and attached to the unit.

Recognize safety information. This is the safety-alert symbol . When you see this symbol on the unit and in instructions or manuals, be alert to the potential for personal injury. Understand these signal words: DANGER, WARNING, and CAUTION. These words are used with the safety-alert symbol. DANGER identifies the most serious hazards which **will** result in severe personal injury or death. WARNING signifies hazards which **could** result in personal injury or death. CAUTION is used to identify unsafe practices which **may** result in minor personal injury or product and property damage. NOTE is used to highlight suggestions which **will** result in enhanced installation, reliability, or operation.

WARNING

ELECTRICAL SHOCK HAZARD

Failure to follow this warning could result in personal injury or death.

Before installing or servicing system, always turn off main power to system and tag. There may be more than one disconnect switch. Turn off accessory heater power switch if applicable.

CAUTION

CUT HAZARD

Failure to follow this caution may result in personal injury.

Sheet metal parts may have sharp edges or burrs. Use care and wear appropriate clothing.

INTRODUCTION

The PH3Z packaged heat pump is fully self-contained and designed for outdoor installation (See Fig. 1). Standard units are shipped in a horizontal-discharge configuration for installation on a ground-level slab or directly on the ground if local codes permit. Standard units can be converted to downflow (vertical) discharge configurations for rooftop applications with a field supplied plenum.

RECEIVING AND INSTALLATION

Step 1 — Check Equipment

IDENTIFY UNIT

The unit model number and serial number are printed on the unit informative plate. Check this information against shipping papers.

INSPECT SHIPMENT

Inspect for shipping damage while unit is still on shipping pallet. If unit appears to be damaged or is torn loose from its anchorage, have it examined by transportation inspectors before removal. Forward claim papers directly to transportation company. Manufacturer is not responsible for any damage incurred in transit.

Check all items against shipping list. Immediately notify the nearest equipment distribution office if any item is missing. To prevent loss or damage, leave all parts in original packages until installation.

Step 2 — Provide Unit Support

For hurricane tie downs, contact distributor for details and PE (Professional Engineering) Certificate, if required.

SLAB MOUNT

Place the unit on a solid, level concrete pad that is a minimum of 4 in. (102 mm) thick with 2 in. (51 mm) above grade. The slab should extend approximately 2 in. (51 mm) beyond the casing on all 4 sides of the unit. Do not secure the unit to the slab *except* when required by local codes.

A 6-in. (152 mm) wide gravel apron should be used around the flat surface to prevent airflow blockage by grass or shrubs. The unit should be level within 1/4 in. (6 mm). This is necessary for the unit drain to function properly.

GROUND MOUNT

The unit may be installed either on a slab or placed directly on the ground if local codes permit. Place the unit on level ground prepared with gravel for condensate discharge.

Step 3 — Provide Clearances

The required minimum service clearances are shown in Fig. 5. Adequate ventilation and outdoor air must be provided.

The outdoor fan draws air through the outdoor coil and discharges it through the top fan grille. Be sure that the fan discharge does not recirculate to the outdoor coil. Do not locate the unit in either a corner or under an overhead obstruction. The minimum clearance under a partial overhang (such as a normal house overhang) is 48 in. (1219 mm) above the unit top. The maximum horizontal extension of a partial overhang must not exceed 48 in. (1219 mm).

IMPORTANT: Do not restrict outdoor airflow. An air restriction at either the outdoor-air inlet or the fan discharge may be detrimental to compressor life.

Do not place the unit where water, ice, or snow from an overhang or roof will damage or flood the unit. Do not install the unit on carpeting or other combustible materials. Slab-mounted units should be at least 4 in. (102 mm) above the highest expected water and runoff levels. Do not use unit if it has been under water.

Step 4 — Place Unit

Unit can be moved with the rigging holds provided in the unit base. Refer to Table 1 for operating weights. Use extreme caution to prevent damage when moving the unit. Unit must remain in an upright position during all moving operations. The unit must be level with in 1/4 in. (6 mm) for proper condensate drainage; the ground-level pad must be level before setting the unit in place. When a field-fabricated support is used, be sure that the support is level and that it properly supports the unit.

Step 5 — Select and Install Ductwork

The design and installation of the duct system must be in accordance with the standards of the NFPA for installation of non-residence type air conditioning and ventilating systems, NFPA 90A or residence type, NFPA 90B and/or local codes and ordinances.

Select and size ductwork, supply-air registers, and return air grilles according to ASHRAE (American Society of Heating, Refrigeration, and Air Conditioning Engineers) recommendations.

Use the duct flanges provided on the supply- and return-air openings on the side of the unit. See Fig. 5 for connection sizes and locations. The 14-in. (356 mm) round duct collars are shipped inside the unit attached to the base pan in the indoor blower compartment. They are field-installed and must be removed from the indoor blower compartment prior to start-up, even if they are not used for installation.

When designing and installing ductwork, consider the following:

⚠ **CAUTION**

UNIT DAMAGE HAZARD

Failure to follow this caution may result in damage to unit components.

When connecting ductwork to units, do not drill deeper than 3/4 in. (19 mm) in shaded area shown in Fig. 2 or coil may be damaged.

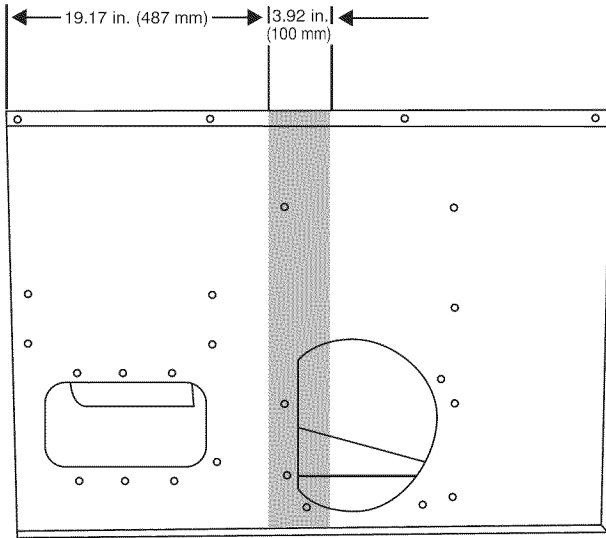

Fig. 2 - Area Not to be Drilled More Than 3/4-in. (19 mm) Deep

1. All units should have field-supplied filters or accessory filter rack installed in the return-air side of the unit. Recommended sizes for filters are shown in Table 1.
2. Avoid abrupt duct size increases and reductions. Abrupt change in duct size adversely affects air performance.

IMPORTANT: Use flexible connectors between ductwork and unit to prevent transmission of vibration. Use suitable gaskets to ensure weather tight and airtight seal. When electric heat is installed, use fireproof canvas (or similar heat resistant material) connector between ductwork and unit discharge connection. If flexible duct is used, insert a sheet metal sleeve inside duct. Heat resistant duct connector (or sheet metal sleeve) must extend 24-in. (610 mm) from electric heater element.

3. Size ductwork for cooling air quantity (cfm). The minimum air quantity for proper electric heater operation is listed in Table 2. Heater limit switches may trip at air quantities below those recommended.
4. Seal, insulate, and weatherproof all external ductwork. Seal, insulate and cover with a vapor barrier all ductwork passing through conditioned spaces. Follow latest Sheet Metal and Air Conditioning Contractors National Association (SMACNA) and Air Conditioning Contractors Association (ACCA) minimum installation standards for residential heating and air conditioning systems.
5. Secure all ducts to building structure. Flash, weatherproof, and vibration-isolate duct openings in wall or roof according to good construction practices.

Fig. 6 shows a typical duct system with PH3Z unit installed.

CONFIGURING UNITS FOR DOWNFLOW (VERTICAL) DISCHARGE

⚠ **WARNING**

ELECTRICAL SHOCK HAZARD

Failure to follow this warning could result in personal injury or death.

Before performing service or maintenance operations on the system, turn off main power to unit and install lockout tag.

Units are dedicated side supply products. They are not convertible to vertical air supply. A field-supplied plenum must be used to convert to vertical air discharge.

Step 6 — Connect Condensate Drain

NOTE: When installing condensate drain connection be sure to comply with local codes and restrictions.

Unit removes condensate through a 1-3/64 in. (27 mm) ID hole (using 3/4-in. (19 mm) OD piping or tubing) which is located at the end of the unit. See Fig. 5 for location of condensate connection.

Condensate water can be drained directly onto the roof in rooftop installations (where permitted) or onto a gravel apron in ground level installations. Install a field-supplied condensate trap at end of condensate connection to ensure proper drainage. Make sure that the outlet of the trap is at least 1 in. (25 mm) lower than the drain pan condensate connection to prevent the pan from overflowing (See Fig. 3 and 4). When using a gravel apron, make sure it slopes away from the unit.

If the installation requires draining the condensate water away from the unit, install a 2-in. (51 mm) trap using a 3/4-in. (19 mm) OD tubing or pipe. (See Fig. 3 and 4.) Make sure that the outlet of the trap is at least 1 in. (25 mm) lower than the unit drain-pan condensate connection to prevent the pan from overflowing. Prime the trap with water. Connect a drain tube using a minimum of 3/4-in. (19 mm) PVC, 3/4-in. (19 mm) CPVC, or 3/4-in. copper pipe (all field supplied). Do not undersize the tube. Pitch the drain tube downward at a slope of at least 1 in. (25 mm) for every 10 ft (3 m) of horizontal run. Be sure to check the drain tube for leaks. Prime trap at the beginning of the cooling season start-up. Allowable glues for condensate trap connection are: Standard ABS, CPVC, or PVC cement.

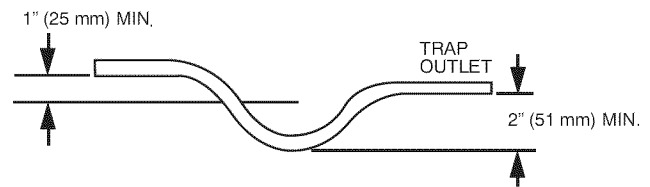

Fig. 3 - Condensate Trap

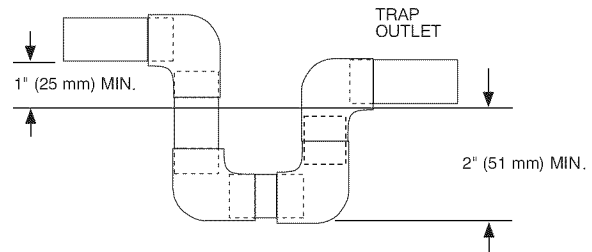

Fig. 4 - PVC Condensate Trap

PH3Z

UNIT	ELECTRICAL CHARACTERISTICS	UNIT WT.		UNIT HEIGHT		CENTER OF GRAVITY MM/IN		
		LBS.	KG.	A	X	Y	Z	
PH3Z024	208-230-1-60	293	133	30.13 [765]	14.0 [356]	19.0 [483]	15.0 [381]	
PH3Z030	208-230-1-60	324	147	34.13 [867]	14.0 [356]	19.0 [483]	16.0 [406]	
PH3Z036	208-230-1-60	377	171	42.13 [1070]	14.0 [356]	19.0 [483]	19.8 [503]	
PH3Z042	208-230-1-60	389	177	42.13 [1070]	14.0 [356]	19.0 [483]	21.9 [556]	
PH3Z048	208-230-1-60	384	175	42.13 [1070]	14.0 [356]	19.0 [483]	19.8 [503]	
PH3Z060	208-230-1-60	433	197	42.13 [1070]	14.0 [356]	19.0 [483]	21.9 [556]	

REQUIRED CLEARANCES TO COMBUSTIBLE MATL.

	MILLIMETERS (IN)
TOP OF UNIT.....	0
BOTTOM OF UNIT.....	0
SIDE OF UNIT WITH DUCT OPENINGS.....	0
SIDE OF UNIT OPPOSITE DUCT OPENINGS.....	0

NEC. REQUIRED CLEARANCES.

	MILLIMETERS (IN)
BETWEEN UNITS, POWER ENTRY SIDE.....	1066.8 [42.00]
UNIT AND UNGROUNDED SURFACES, POWER ENTRY SIDE.....	914.0 [36.00]
UNIT AND BLOCK OR CONCRETE WALLS AND OTHER GROUNDED SURFACES, POWER ENTRY SIDE.....	1066.8 [42.00]

REQUIRED CLEARANCE FOR SERVICING

	MILLIMETERS (IN)
TOP OF UNIT.....	914.0 [36.00]
SIDE OF UNIT OPPOSITE DUCT OPENINGS.....	762.0 [30.00]
SIDE OF UNIT WITH POWER ENTRY.....	762.0 [30.00]
(EXCEPT FOR NEC REQUIREMENTS)	

NOTE: CLEARANCES MUST BE MAINTAINED TO PREVENT RECIRCULATION OF AIR FROM OUTDOOR FAN DISCHARGE. A REMOVABLE FENCE OR BARRICADE REQUIRES NO CLEARANCE.

DIMENSIONS IN [] ARE IN INCHES

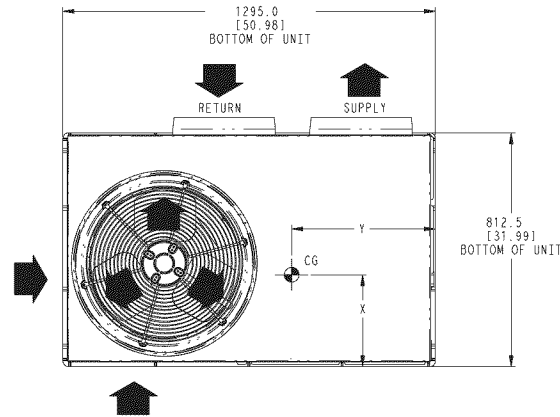

TOP VIEW

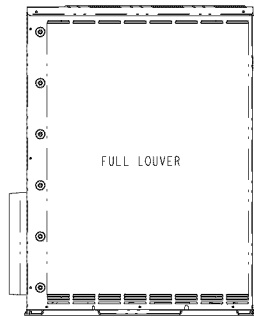

LEFT SIDE VIEW

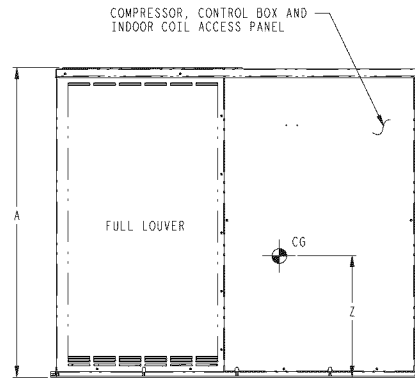

FRONT VIEW

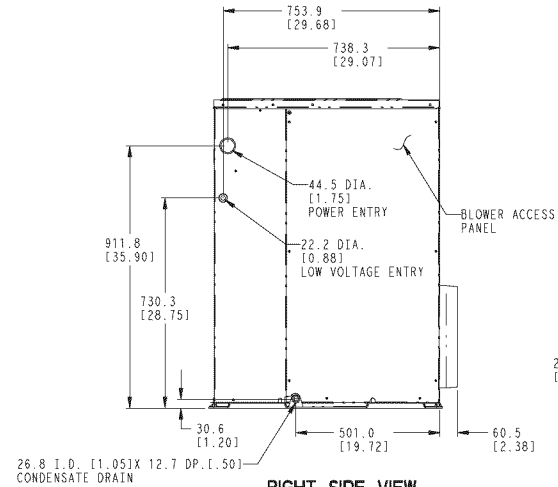

RIGHT SIDE VIEW

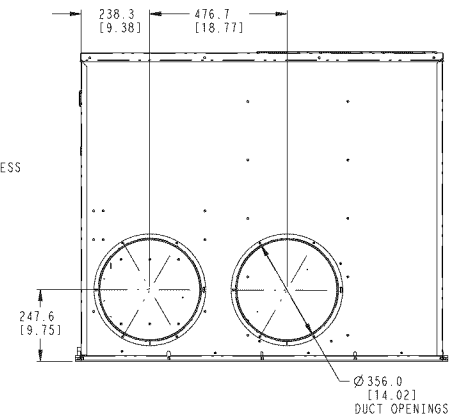

REAR VIEW

50ZH500442

REV
3.0

Fig. 5 - Unit Base Dimensions, PH3Z024-060

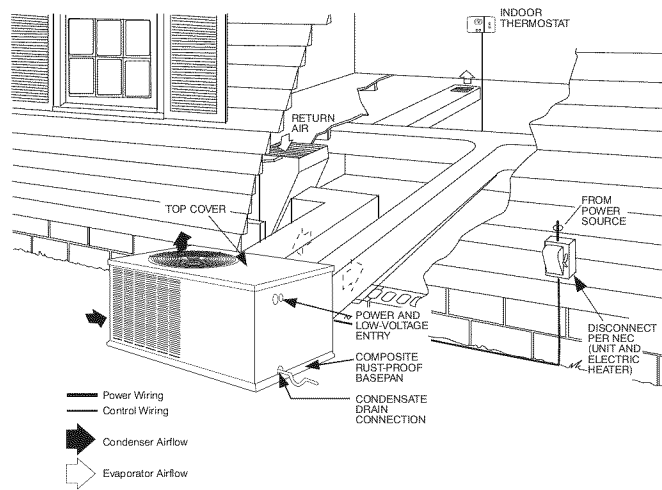

Fig. 6 - Typical Installation

A08207

PHSZ

Table 1 – Physical Data

UNIT SIZE	024	030	036	042	048	060
NOMINAL CAPACITY (ton)	2	2-1/2	3	3-1/2	4	5
OPERATING WEIGHT (lb)	293	324	377	389	384	433
(kg)	133	147	171	176	174	196
COMPRESSOR	Scroll			Ultra Tech Scroll		
REFRIGERANT (R-22)						
Quantity (lb)	7.5	10.3	10.3	11.9	11.4	13.3
(kg)	3.4	4.7	4.7	5.4	5.2	6.0
REFRIGERANT METERING DEVICE	AccuRater®			TXV		
Orifice ID (in.)	0.067	0.067	0.082	0.086	–	–
Orifice OD (in.)	0.049	0.057	0.059	0.063	0.070	0.073
CONDENSER COIL	Copper Tubes, Aluminum Plate Fins					
Rows...Fins/in.	2...21	2...21	2...21	2...21	2...21	2...21
Face Area (sq. ft.)	11.1	12.7	15.8	15.8	13.3	15.8
CONDENSER FAN	Propeller					
Nominal Cfm	2600	2600	3200	3200	3200	3300
Diameter (in.)	20	20	20	20	20	20
(mm)	508	508	508	508	508	508
Motor HP (RPM)	1/8 (825)	1/8 (825)	1/4 (1100)	1/4 (1100)	1/4 (1100)	1/2 (1100)
EVAPORATOR COIL	Copper Tubes, Aluminum Plate Fins					
Rows...Fins/in.	3...17	3...17	4...17	4...17	4...17	4...17
Face Area (sq. ft.)	4.3	4.9	4.9	6.1	4.9	6.1
Evaporator blower	Direct Drive					
Nominal Airflow (Cfm)	800	1000	1200	1400	1600	1875
Size (in.)	10x8		11x9		11x10	
(mm)	254 x 203		279 x 229		279 x 254	
Motor HP (RPM)	1/2 (1050)	1/2 (1050)	3/4 (1050)	3/4 (1050)	1 (1050)	1 (1050)
CONNECTING DUCT SIZES	Round					
Supply Air (in.)	14					
(mm)	356					
Return Air (in.)	14					
(mm)	356					
Return-Air Filters* Throwaway (in.)	24 x 24		24 x 30		30 x 30	
(mm)	610 x 610		610 x 762		762 x 762	

*Required filter sizes shown are based on the ARI (Air conditioning & Refrigeration Institute) rated airflow at a velocity of 300 ft/min (91 m) for throwaway type or 450 ft/min (137 m) for high capacity type. Recommended filters are 1-in. (25 mm) thick.

Table 2 – Minimum Airflow for Safe Electric Heater Operation

Unit Size	Minimum Airflow (CFM)				
	5kW	7.5kW	10kW	15kW	20kW
024	500	650	750	-	-
030	600	800	1050	-	-
036	600	800	1050	1150	1200
042	600	800	1050	1150	1200
048	600	800	1050	1150	1200
060	600	800	1050	1150	1200

Step 7 — Install Electrical Connections

PH3Z

⚠ WARNING

ELECTRICAL SHOCK HAZARD

Failure to follow this warning could result in personal injury or death.

The unit cabinet must have an uninterrupted, unbroken electrical ground to minimize the possibility of personal injury if an electrical fault should occur. This ground may consist of an electrical wire connected to the unit ground screw in the control compartment, or conduit approved for electrical ground when installed in accordance with NEC, ANSI/NFPA 70 American National Standards Institute/ National Fire Protection Association (latest edition) (in Canada, Canadian Electrical Code CSA C22.1) and local electrical codes.

⚠ CAUTION

UNIT COMPONENT DAMAGE HAZARD

Failure to follow this caution may result in damage to the unit being installed.

1. Make all electrical connections in accordance with NEC ANSI/NFPA 70 (latest edition) and local electrical codes governing such wiring. In Canada, all electrical connections must be in accordance with CSA standard C22.1 Canadian Electrical Code Part 1 and applicable local codes. Refer to unit wiring diagram.
2. Use only copper conductor for connections between field-supplied electrical disconnect switch and unit. **DO NOT USE ALUMINUM WIRE.**
3. Be sure that high-voltage power to unit is within operating voltage range indicated on unit rating plate. On 3-phase units, ensure phases are balanced within 2 percent. Consult local power company for correction of improper voltage and/or phase imbalance.
4. Do not damage internal components when drilling through any panel to mount electrical hardware, conduit, etc.

HIGH-VOLTAGE CONNECTIONS

The unit must have a separate electrical service with a field-supplied, waterproof disconnect switch mounted at, or within sight from the unit. Refer to the unit rating plate, NEC and local codes for maximum fuse/circuit breaker size and minimum circuit amps (ampacity) for wire sizing.

The field-supplied disconnect may be mounted on the unit over the high-voltage inlet hole when the standard power and low-voltage entry points are used. See Fig. 6 and 7 for acceptable location.

Operation of unit on improper line voltage constitutes abuse and may cause unit damage that could affect warranty.

ROUTING POWER LEADS INTO UNIT

Use only copper wire between disconnect and unit. The high-voltage leads should be in a conduit until they enter the unit; conduit termination at the unit must be watertight. Run the high-voltage leads through the hole on the control box side of the unit (See Fig. 7). When the leads are inside the unit, run leads to the control box (See Fig. 8). For single-phase units, connect leads to the black and yellow wires (See Fig. 9).

CONNECTING GROUND LEAD TO UNIT GROUND

Connect the ground lead to the chassis using the unit ground in the control box (See Fig. 8 and 9).

ROUTING CONTROL POWER WIRES (24-V)

Form a drip-loop with the thermostat leads before routing them into the unit. Route the thermostat leads through grommeted hole provided in unit into unit control box (See Fig. 7). Connect thermostat leads and unit power leads as shown in Fig. 9, 10 and 11.

Route thermostat wires through grommet providing a drip-loop at the panel. Connect low-voltage leads to the thermostat as shown in Fig. 10 & 11.

The unit transformer supplies 24-v power for complete system including accessory electrical heater. Transformer is factory wired for 230-v operation.

ACCESSORY ELECTRIC HEAT WIRING

Refer to accessory electric heat installation instructions for information on installing accessory electric heat. Accessory electric heat wiring is shown in Fig. 17 and 18.

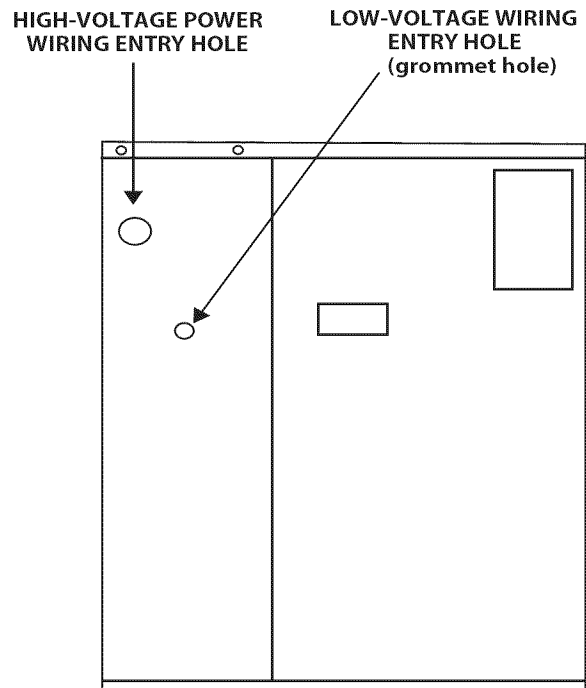

Fig. 7 - Unit Electrical Connection

A08407

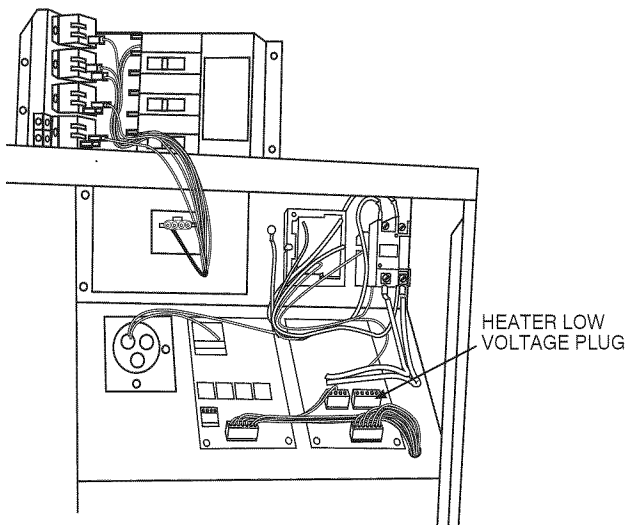

Fig. 8 - Control Box Wiring

A05388

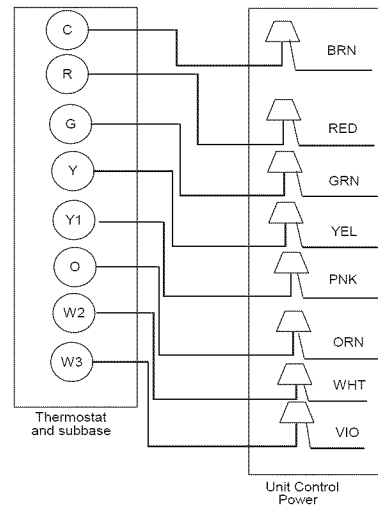

Fig. 11 - Control Connections (Sizes 048-060)

A05208

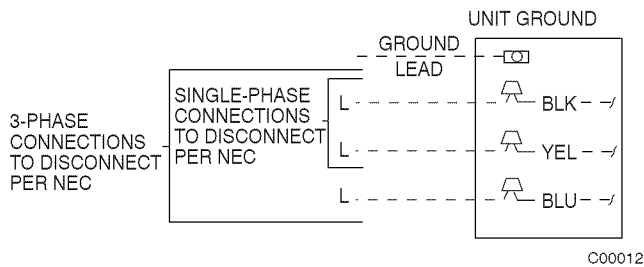

Fig. 9 - Line Power Connections

C00012

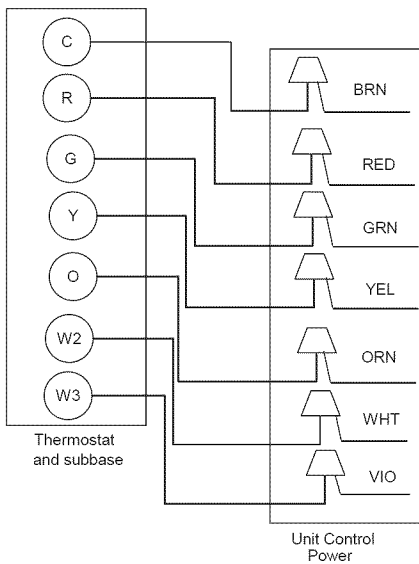

Fig. 10 - Control Connections (Sizes 024-042)

A05207

PRE-START-UP

⚠ WARNING

FIRE, EXPLOSION, ELECTRICAL SHOCK HAZARD

Failure to follow this warning could result in personal injury or death and/or property damage.

1. Follow recognized safety practices and wear protective goggles when checking or servicing refrigerant system.
2. Relieve and recover all refrigerant from system before touching or disturbing anything inside terminal box if refrigerant leak is suspected around compressor terminals.
3. Never attempt to repair soldered connection while refrigerant system is under pressure.
4. Do not use torch to remove any component. System contains oil and refrigerant under pressure.
5. To remove a component, wear protective goggles and proceed as follows:
 - a. Shut off electrical power to unit and install lockout tag.
 - b. Relieve and reclaim all refrigerant from system using both high- and low-pressure ports.
 - c. Cut component connecting tubing with tubing cutter and remove component from unit.
 - d. Carefully unsweat remaining tubing stubs when necessary. Oil can ignite when exposed to flame.

Proceed as follows to inspect and prepare the unit for initial start-up:

1. Remove all access panels.
2. Read and follow instructions on all DANGER, WARNING, CAUTION, and INFORMATION labels attached to, or shipped with unit.
3. Make the following inspections:
 - a. Inspect for shipping and handling damages, such as broken lines, loose parts, disconnected wires, etc.
 - b. Inspect for oil at all refrigerant tubing connections and on unit base. Detecting oil generally indicates a refrigerant leak. Leak test all refrigerant tubing connections using electronic leak detector, or liquid-soap solution. If a refrigerant leak is detected, see Check for Refrigerant Leaks section.

PHSZ

- c. Inspect all field- and factory-wiring connections. Be sure that connections are completed and tight.
 - d. Ensure wires do not touch refrigerant tubing or sharp sheet metal edges.
 - e. Inspect coil fins. If damaged during shipping and handling, carefully straighten fins with a fin comb.
4. Verify the following conditions:
- a. Make sure that outdoor-fan blade is correctly positioned in fan orifice. Top edge of blade should be 3.125 in. (79 mm) down from outdoor coil outlet grille (size 024-048, See Fig. 19) or hub should be 0.708-in. (18 mm) away from motor end bell (size 060, See Fig. 19). See Outdoor Fan Adjustment section.
 - b. Make sure that air filter is in place.
 - c. Make sure that condensate drain pan and trap are filled with water to ensure proper drainage.
 - d. Make sure that all tools and miscellaneous loose parts have been removed.

START-UP

Step 1 — Check for Refrigerant Leaks

Proceed as follows to locate and repair a refrigerant leak and to charge the unit:

1. Locate leak and make sure that refrigerant system pressure has been relieved and reclaimed from both high- and low-pressure ports.
2. Repair leak following accepted practices.

NOTE: Install a filter drier whenever the system has been opened for repair.

Step 2 — Start-Up Cooling and Make Adjustments

Complete the required procedures given in the Pre-Start-Up section before starting the unit. Do not jumper any safety devices when operating the unit. Do not operate the unit in cooling mode when the outdoor temperature is below 40°F (4.4°C) (unless accessory low-ambient kit is installed). Do not rapid cycle the compressor. Allow 5 min. between “on” cycles to prevent compressor damage.

CHECKING COOLING AND HEATING CONTROL OPERATION

Start and check the unit for proper cooling control operation as follows:

1. Place room thermostat SYSTEM switch in OFF position. Observe that blower motor starts when FAN switch is placed in ON position and shuts down within 60 sec. (for 024-042) or 90 seconds (for 048 and 060) when FAN switch is placed in AUTO position.
2. Place SYSTEM switch in COOL position and FAN switch in AUTO position. Set control below room temperature. Observe that compressor, outdoor fan, and indoor blower motors start and that reversing valve shifts. Observe that cooling cycle shuts down when control setting is satisfied. Reversing valve (RV) remains energized.
3. Place system switch in HEAT position. Observe that compressor, indoor fan and outdoor fan energize (Reversing Valve is deenergized in heat pump heating mode). Set control above room temperature. Observe that heating cycle shuts down when control setting is satisfied.

4. When using an automatic changeover room thermostat, place both SYSTEM and FAN switches in AUTO positions. Observe that unit operates in Cooling mode when temperature control is set to call for Cooling (below room temperature), and unit operates in Heating mode when temperature control is set to call for Heating (above room temperature).

Step 3 — Refrigerant Charge

Refrigerant Charge — Amount of refrigerant charge is listed on unit nameplate and in Table 1. Refer to Payne Refrigerant Service Techniques Manual, Refrigerants section. Unit panels must be in place when unit is operating during charging procedure. Unit must operate a minimum of 15 minutes before checking charge.

NO CHARGE

Refer to Payne Refrigerant Service Techniques. Use standard evacuating techniques. After evacuating system, weigh in the specified amount of refrigerant (refer to Table 1).

LOW CHARGE COOLING

024-042 units:

1. Measure suction line pressure by attaching a gauge to the service port.
2. Measure the suction line temperature by attaching a temperature sensing device to it.
3. Insulate the temperature sensing device so that the outdoor ambient doesn't affect the reading.
4. Locate the measured suction line pressure in the top row of Table 5 and the measured outdoor ambient temperature in the left column of the table. Based on the two values, determine the required suction line temperature.
5. If the measured suction line temperature is greater than the tabulated temperature, add charge in the system.

048 and 060 units:

1. Measure discharge line pressure by attaching a gauge to the service port.
2. Measure the liquid line temperature by attaching a temperature sensing device to it.
3. Insulate the temperature sensing device so that the outdoor ambient doesn't affect the reading.
4. Refer to the required subcooling in Tables 3 to find the required subcooling based on the model size and the outdoor ambient temperature.
5. Interpolate if the outdoor temperature lies in between the table values. Extrapolate if the temperature lies beyond the table range.
6. Find the pressure value corresponding to the measured pressure on the compressor discharge line.
7. Read across from the pressure reading to obtain the Liquid line temperature for a required subcooling.
8. Add charge if the measured temperature is higher than the liquid line temperature value in the table.
9. Add charge using the service connection on the suction line of the compressor.

HEATING MODE CHARGE

Do not attempt to adjust charge by cooling methods while in heat pump heating mode. Recover refrigerant and weigh in according to unit data plate refrigerant data.

Table 3 – Required Subcooling

Model Size	Required Subcooling °F(°C)					Required Liquid Line Temperature for a Specific Subcooling (R-22)										
	Outdoor Ambient Temperature					Pressure (psig)	Required Subcooling (°F)				Pressure (kPa)	Required Subcooling (°C)				
	75 (24)	82 (28)	85 (29)	95 (35)	105 (41)		5	10	15	20		3	6	8	11	
048	18 (10)	17 (9.4)	17 (9.4)	16 (8.9)	14 (7.8)	134	71	66	61	56	924	24	22	19	16	
049	24 (13.3)	23 (12.8)	22 (12.2)	22 (12.2)	20 (11.1)	141	74	69	64	59	972	26	23	21	18	
060	21 (11.7)	21 (11.7)	20 (11.1)	19 (10.6)	16 (8.9)	156	80	75	70	65	1075	30	27	24	21	
						163	83	78	73	68	1124	31	28	26	23	
						170	86	81	76	71	1172	33	30	27	24	
						177	89	84	79	74	1220	34	31	29	26	
						184	91	86	81	76	1268	36	33	30	27	
						191	94	89	84	79	1317	37	34	31	29	
Charging Procedure (CHARGE SYSTEM IN HIGH CAPACITY)																
1- Measure Discharge line pressure by attaching a gauge to the service port.						198	96	91	86	81	1365	38	36	33	30	
2- Measure the Liquid line temperature by attaching a temperature sensing device to it.						205	98	93	88	83	1413	40	37	34	31	
3- Insulate the temperature sensing device so that the Outdoor Ambient doesn't affect the reading.						213	101	96	91	86	1468	41	38	36	33	
4- Refer to the required Subcooling in the table to find the required Subcooling based on the model size and the Outdoor Ambient temperature.						221	104	99	94	89	1524	43	40	37	34	
5- Interpolate if the Outdoor temperature lies in between the table values.						229	106	101	96	91	1579	44	41	38	36	
6- Find the Pressure Value corresponding to the measured Pressure on the Compressor Discharge line.						237	108	103	98	93	1634	45	42	40	37	
7- Read across from the Pressure reading to obtain the Liquid line temperature for a required Subcooling.						245	111	106	101	96	1689	47	44	41	38	
8- Add Charge if the measured temperature is higher than the liquid line temperature value in the table.						253	113	108	103	98	1744	48	45	42	40	
9- Add Charge using the service connection on the Suction line of the Compressor.						262	116	111	106	101	1806	49	46	44	41	
10- Remove charge if the measured temperature is lower than the liquid line temperature in the table.						271	118	113	108	103	1868	51	48	45	42	
						280	121	116	111	106	1930	52	49	46	44	
						289	123	118	113	108	1992	53	51	48	45	
						298	125	120	115	110	2054	55	52	49	46	
						307	128	123	118	113	2116	56	53	50	48	
						317	130	125	120	115	2185	57	54	52	49	
						327	132	127	122	117	2254	59	56	53	50	
						337	135	130	125	120	2323	60	57	54	52	
						347	137	132	127	122	2392	61	58	56	53	
						357	139	134	129	124	2461	62	60	57	54	
						367	142	137	132	127	2530	64	61	58	55	

DRAWING NUMBER 50ZH500375 REV 5.0

A08406

Step 4 — Indoor Airflow and Airflow Adjustments

NOTE: For cooling operation, the recommended airflow is 350 to 450 cfm for each 12,000 Btuh of rated cooling capacity.

Table 4 shows dry coil air delivery for horizontal discharge units. Tables 6-8 show pressure drops.

NOTE: Be sure that all supply- and return-air grilles are open, free from obstructions, and adjusted properly.

⚠ WARNING

ELECTRICAL SHOCK HAZARD

Failure to follow this warning could result in personal injury or death.

Disconnect electrical power to the unit and install lockout tag before changing blower speed.

Airflow can be changed by changing the lead connections at the blower motor. To change motor speeds, reposition wire at fan motor speed terminals labeled 1-2-3-4 (refer to Fig. 12).

Remove the speed tap connector labeled 1 through 5 on the motor. While looking at the connector end that is inserted into the motor, gently pry the locking tab outward and remove the wire from the connector. Insert the wire into the desired tap until it locks into place. Be sure new airflow meets the range noted above and minimum electric heat CFM, if equipped. Refer to Table 2 and 4.

All model sizes are factory wired or rated airflow operation.

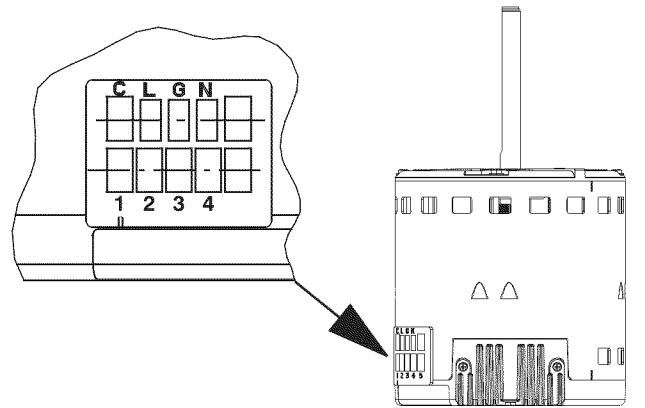

A08412

Fig. 12 - Motor Speed Selection

FOR 208/230V BLOWER MOTORS

The motor lead speed connections are as follows:

SIZE	RATED AIRFLOW	HIGH AIRFLOW
024	Tap 1	Tap 3
030	Tap 2	Tap 4
036	Tap 1	Tap 3
042	Tap 2	Tap 4

SIZE	RATED AIRFLOW		HIGH AIRFLOW	
	Low Stage	High Stage	Low Stage	High Stage
048	Tap 1	Tap 3	Tap 2	Tap 4
060	Tap 1	Tap 3	Tap 2	Tap 4

PHSZ

Step 5 — Unit Controls

All compressors have the following internal-protection controls.

HIGH-PRESSURE RELIEF VALVE

This valve opens when the pressure differential between the low and high side becomes excessive.

LOSS OF CHARGE SWITCH

Located on the outdoor liquid line is a low-pressure switch which functions as a loss-of-charge switch. This switch contains a Schrader core depressor. This switch opens at 7 psig and closes at 22 psig. No adjustment is necessary.

COMPRESSOR OVERLOAD

This overload interrupts power to the compressor when either the current or internal temperature become excessive, and automatically resets when the internal temperature drops to a safe level.

This overload may require up to 60 minutes (or longer) to reset; therefore, if the internal overload is suspected of being open, disconnect the electrical power to the unit and check the circuit through the overload with an ohmmeter or continuity tester.

Step 6 — Compressor Rotation

On 3-Phase units it is important to be certain compressor is rotating in the proper direction. To determine whether or not compressor is rotating in the proper direction:

1. Connect service gages to suction and discharge pressure fittings.
2. Energize the compressor.
3. The suction pressure should drop and the discharge pressure should rise, as is normal on any start-up.

If the suction pressure does not drop and the discharge pressure does not rise to normal levels:

1. Turn off power to the unit and tag disconnect.
2. Reverse any two of the unit power leads.
3. Turn on power to the unit.

The suction and discharge pressure levels should now move to their normal start-up levels.

NOTE: When the compressor is rotating in the wrong direction, the unit makes an elevated level of noise and does not provide cooling.

Step 7 — Sequence of Operation

FAN OPERATION

The FAN switch on the thermostat controls indoor fan operation. When the FAN switch is placed in the ON position, the IFR (indoor-fan relay) is energized through the G terminal on the thermostat. The normally-open contacts close, which then provide power to the indoor (evaporator) fan motor (IFM). The IFM will run continuously when the FAN switch is set to ON.

When the FAN switch is set to AUTO, the thermostat deenergizes the IFR (provided there is not a call for cooling). The contacts open and the IFM is deenergized. The IFM will be energized only when there is a call for cooling, in heat pump heating mode or if the unit is equipped with accessory electric heat, the indoor-fan motor will also run while the accessory electric heat is energized.

NOTE: Some units are equipped with a time-delay relay. On these units, the indoor fan remains on for 30 seconds after G or Y is deenergized.

COOLING OPERATION (SIZES 024-042)

With a call for cooling (Y/Y2), the indoor fan energizes immediately whereas the contactor energizes after a 5 minute time delay (in case of initial start-up) starting the compressor and the outdoor fan motor. When the cooling demand is met, Y/Y2 de-energizes, shutting the compressor, indoor fan and the outdoor fan.

COOLING OPERATION (SIZES 048 AND 060)

These units utilize a 2 stage indoor thermostat. With a first stage call for cooling (Y1), the indoor fan (low stage) energizes immediately whereas the contactor energizes after a 5 minute time delay (in case of an initial start-up) starting the compressor (low stage) and the outdoor fan motor. If the low stage operation cannot satisfy the cooling demand, the second stage cooling (Y2) energizes switching the compressor into high stage cooling through energizing an internal solenoid valve inside the scroll compressor and switching the indoor fan into high stage. When second stage cooling is satisfied, Y2 de-energizes switching the compressor and the indoor fan into low stage cooling. When the low stage cooling demand is met, Y1 de-energizes shutting the compressor, indoor fan and the outdoor fan.

HEATING OPERATION (SIZES 024-042)

With a call for heating (Y1), the indoor fan (low stage) energizes immediately whereas the contactor energizes after a 5 minute time delay (in case of initial start-up) starting the compressor and the outdoor fan motor. If Y/Y2 cannot satisfy the heating demand, the auxiliary or backup heat (W2) energizes. In case of staged heating, W3 is energized if the demand is not met. The highest airflow selected is run while the electric heat is in operation. When heating demand is met, W3, W2 and Y/Y2 sequentially de-energize shutting the compressor, indoor fan and the outdoor fan.

HEATING OPERATION (SIZES 048 AND 060)

With a first stage call for heating (Y1), the indoor fan (low stage) energizes immediately whereas the contactor energizes after a 5 minute time delay (in case of initial start-up) starting the compressor (low stage) and the outdoor fan motor. If the low stage operation cannot satisfy the heating demand, the second stage heating (Y2) energizes switching the compressor into high stage heating through energizing an internal solenoid valve inside the scroll compressor and switching the indoor fan into high stage. The auxiliary or backup heat is controlled by a third stage (W2). If the demand is not met, W3 is energized in case of staged heating. When heating demand is satisfied, W3, W2 and Y2 sequentially de-energize switching the compressor and the indoor fan into low stage heating. When the low stage heating demand is met, Y1 de-energizes shutting the compressor, indoor fan and the outdoor fan.

CONTINUOUS FAN

With the continuous Indoor fan option selected on the thermostat, G is continuously energized. In case of 024-042 units, the selected airflow setting is provided. In case of 048 and 060 units, the system runs low stage (Y1) airflow for continuous fan operation.

DEFROST

Defrost board (DB) is a time and temperature control, which includes a field-selectable time period between checks for defrost (30, 60, 90 and 120 minutes). The time period is factory-set at 60 minutes and should only be adjusted by a trained service person. Electronic timer and defrost cycle start only when contactor is energized and defrost thermostat (DFT) is closed.

Defrost mode is identical to Cooling mode. The outdoor fan motor stops because of "OF1" and "OF2" contacts opening on the defrost board, a bank of optional electric heat turns on to warm air supplying the conditioned space.

ELECTRIC RESISTANCE HEATING

If accessory electric heaters are installed, on a call for second stage or emergency heat, the thermostat energizes W which energizes the heater relay and in turn energizes the electric heaters. The blower motor is energized, unless already running in heat pump heating mode. If the heaters are staged, W2 is energized when the second stage of heating is required. When the need for heating is satisfied, the heater and IFM are de-energized.

SCHEMATIC
208/230-160

PH3Z

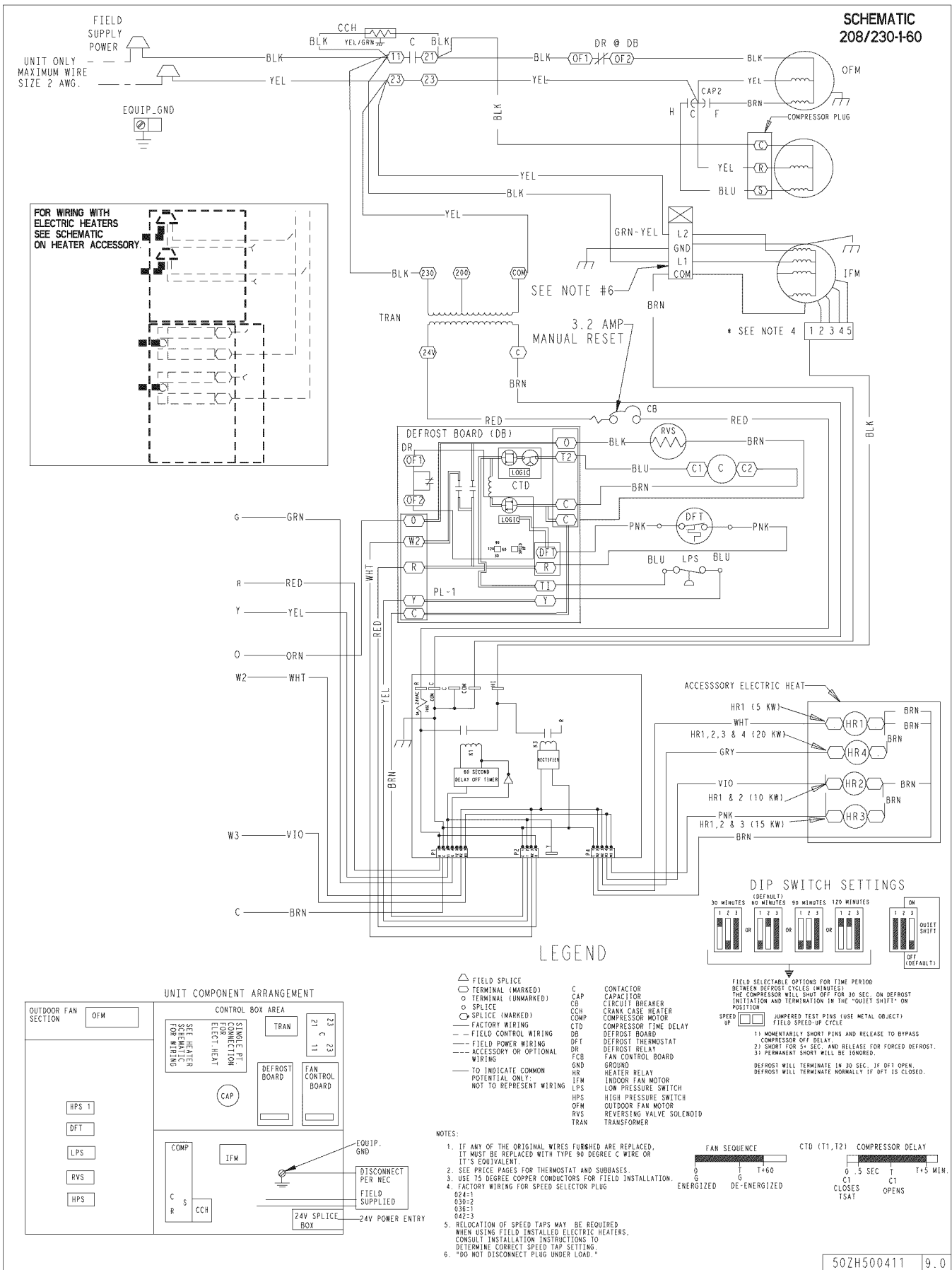
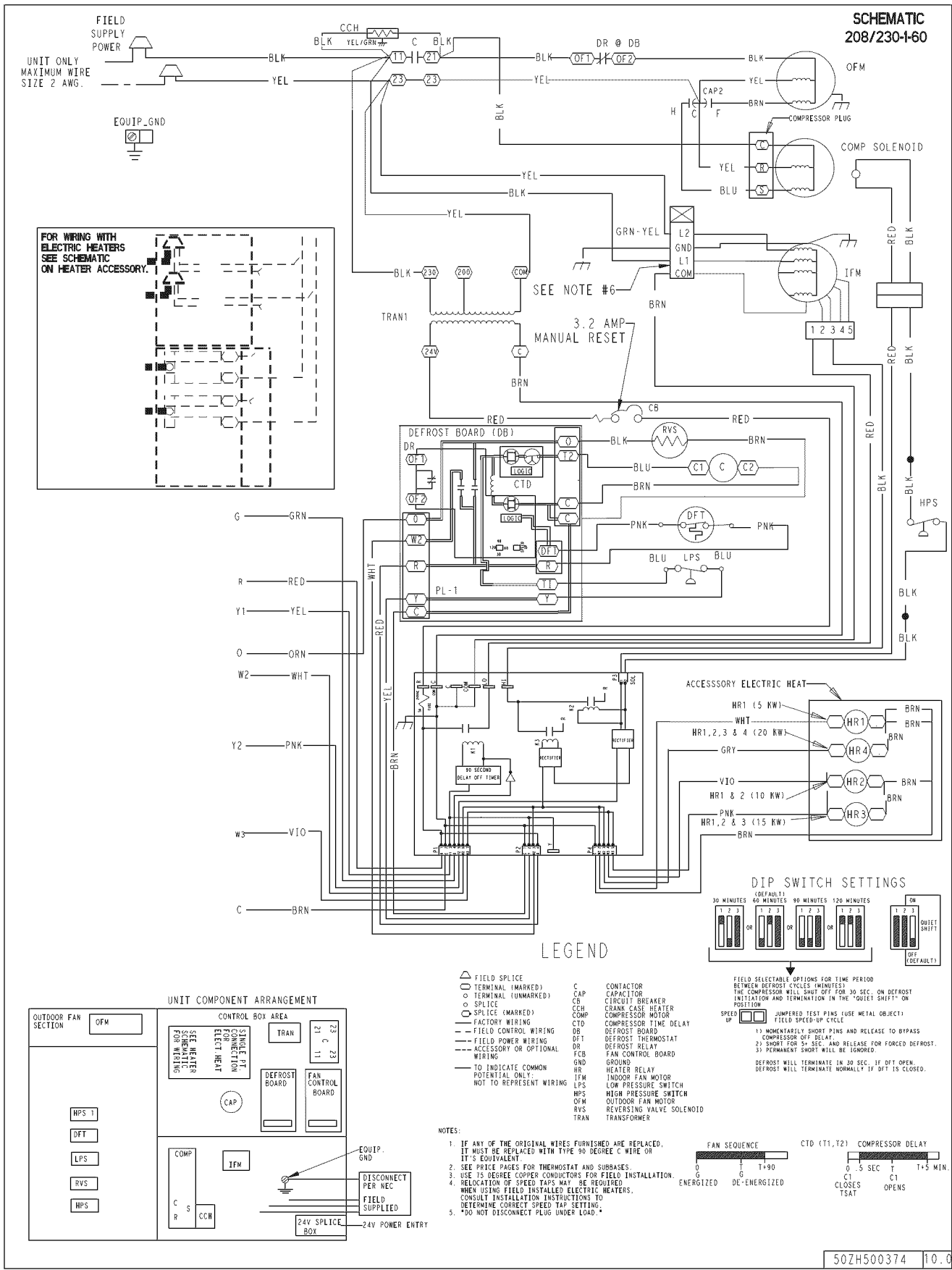

Fig. 13 - Typical Single-Phase Unit Electrical Diagram (Sizes 024-042)

A08209

PH3Z



**SCHEMATIC
208/230-160**

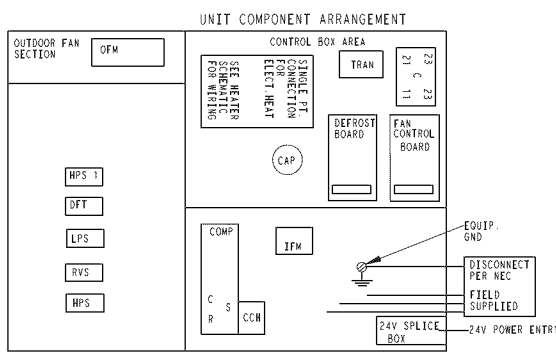
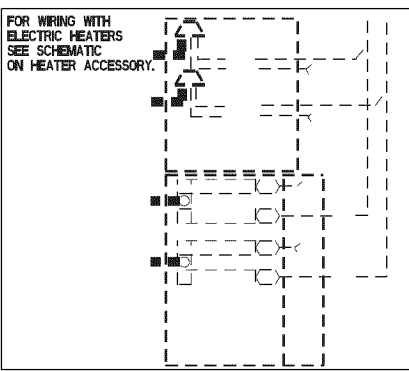

LEGEND

- FIELD SPlice
- TERMINAL (MARKED)
- TERMINAL (UNMARKED)
- SPlice (MARKED)
- SPlice (UNMARKED)
- FACTORY WIRING
- FIELD CONTROL WIRING
- FIELD POWER WIRING
- ACCESSORY OR OPTIONAL WIRING
- TO INDICATE COMMON POTENTIAL ONLY; NOT TO REPRESENT WIRING
- C CONTACTOR
- CAP CAPACITOR
- CB CIRCUIT BREAKER
- CCH CRANK CASE HEATER
- COMP COMPRESSOR MOTOR
- CTD COMPRESSOR TIME DELAY
- DB DEFROST BOARD
- DFT DEFROST THERMOSTAT
- DR DEFROST RELAY
- FCB FAN CONTROL BOARD
- GND GROUND
- HR HEATER RELAY
- IFM INDOOR FAN MOTOR
- LPS LOW PRESSURE SWITCH
- HPS HIGH PRESSURE SWITCH
- OFM OUTDOOR FAN MOTOR
- RVS REVERSING VALVE SOLENOID
- TRAN TRANSFORMER

- NOTES:**
- IF ANY OF THE ORIGINAL WIRES FURNISHED ARE REPLACED, IT MUST BE REPLACED WITH TYPE 90 DEGREE C WIRE OR IT'S EQUIVALENT.
 - SEE PRICE PAGES FOR THERMOSTAT AND SUBBASES.
 - USE 75 DEGREE COPPER CONDUCTORS FOR FIELD INSTALLATION.
 - RELOCATION OF SPEED TAPS MAY BE REQUIRED WHEN USING FIELD INSTALLED ELECTRIC HEATERS. CONSULT INSTALLATION INSTRUCTIONS TO DETERMINE CORRECT SPEED TAP SETTING.
 - DO NOT DISCONNECT PLUG UNDER LOAD.

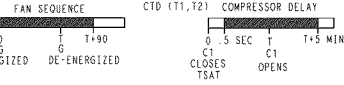
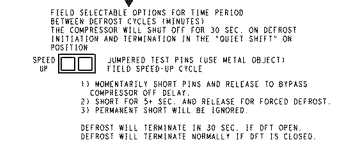

50ZH500374 10.0

A06405

Fig. 14 - Typical Single-Phase Unit Electrical Diagram (Sizes 048-060)

**SCHEMATIC
208/230-3-60**

PH3Z

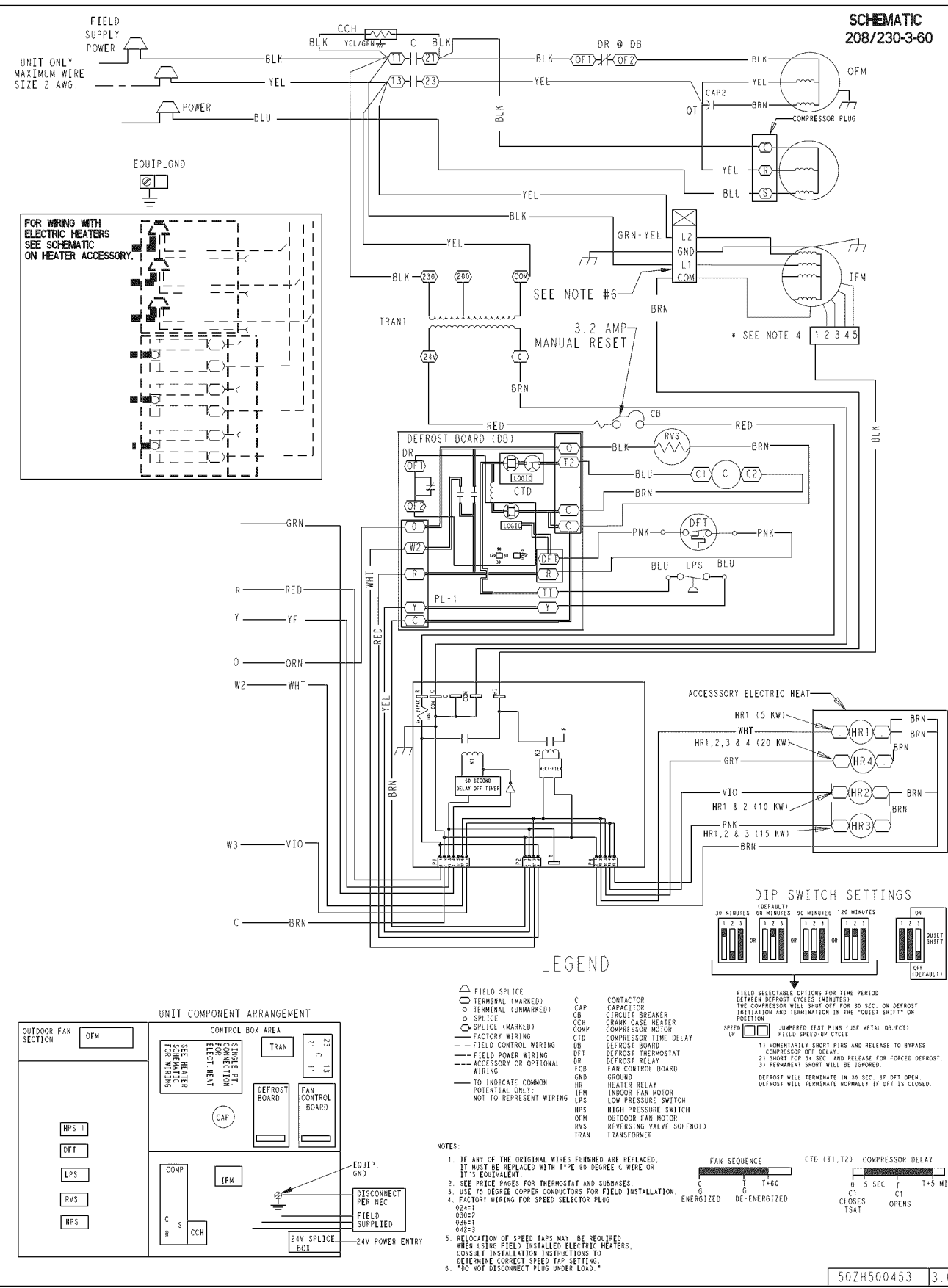

Fig. 15 - Typical Three-Phase Unit Electrical Diagram (Sizes 030-042)

PH3Z

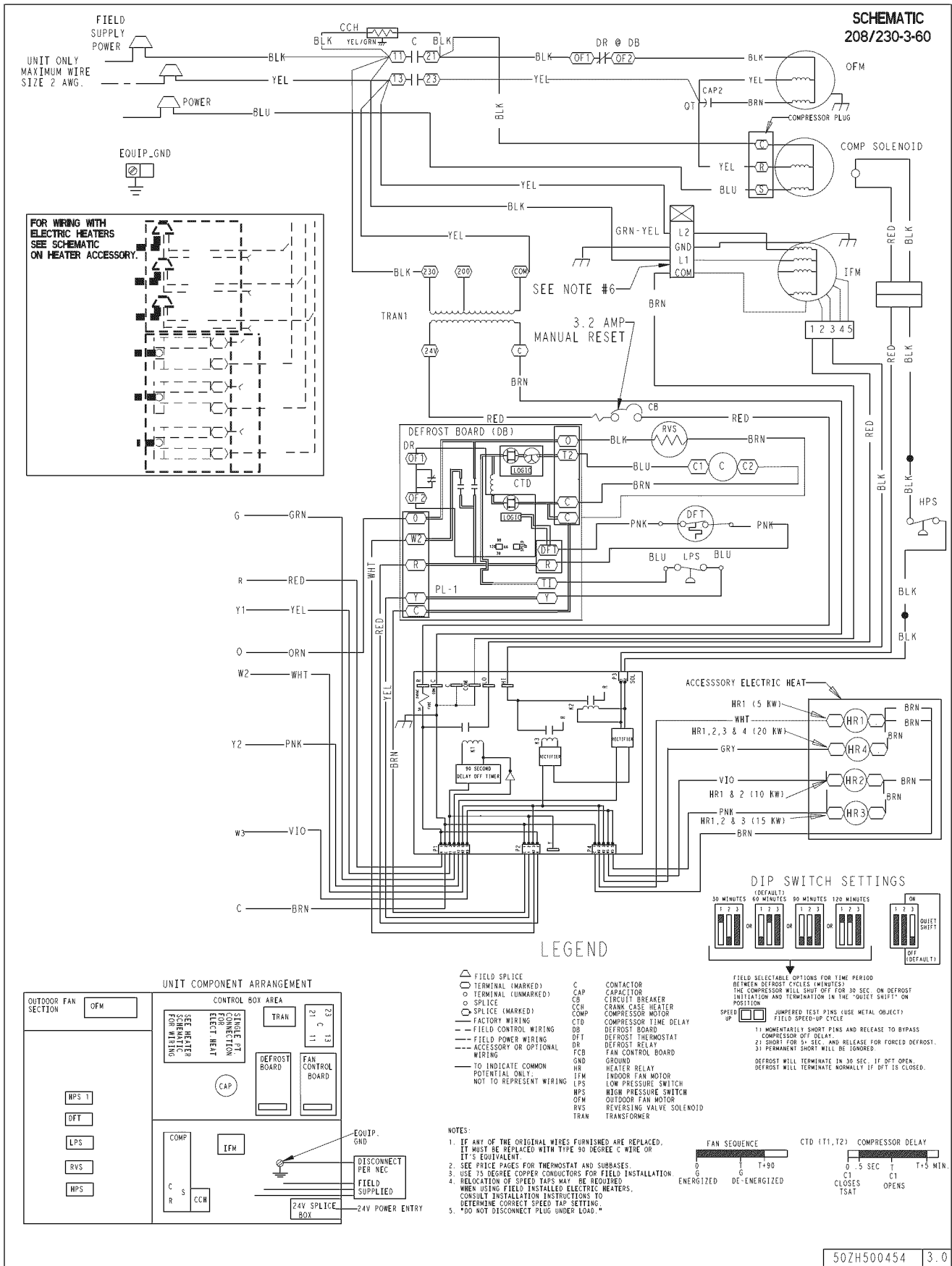

Fig. 16 - Typical Three-Phase Unit Electrical Diagram (Sizes 048-060)

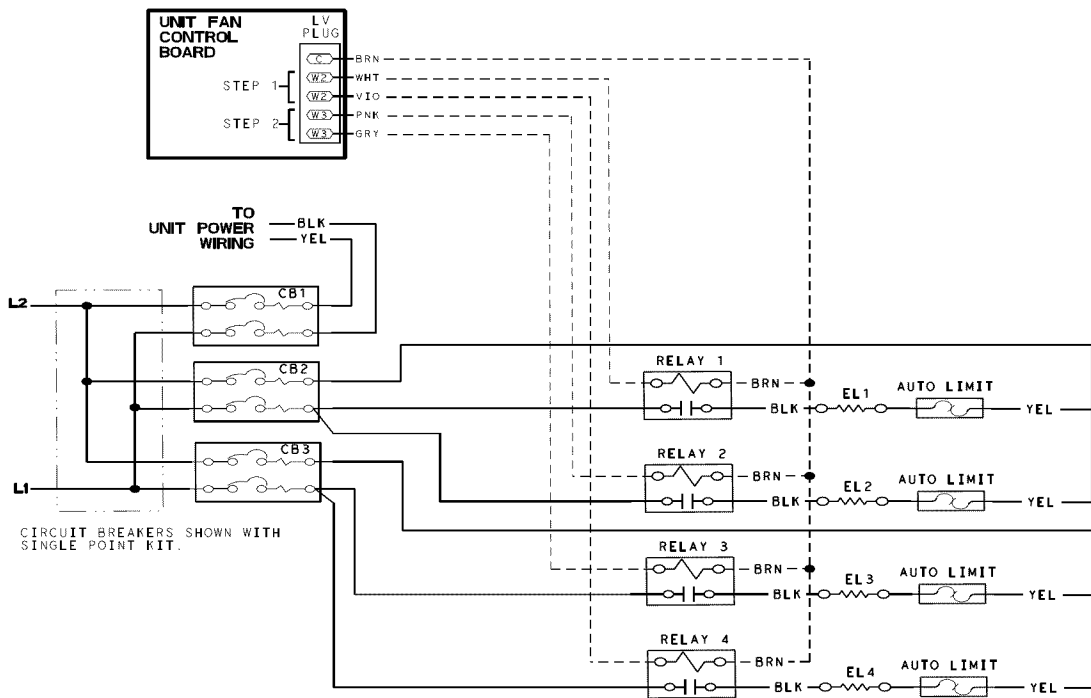

Fig. 17 - Single-Phase Accessory Electric Heater Wiring

A05209

PHSZ

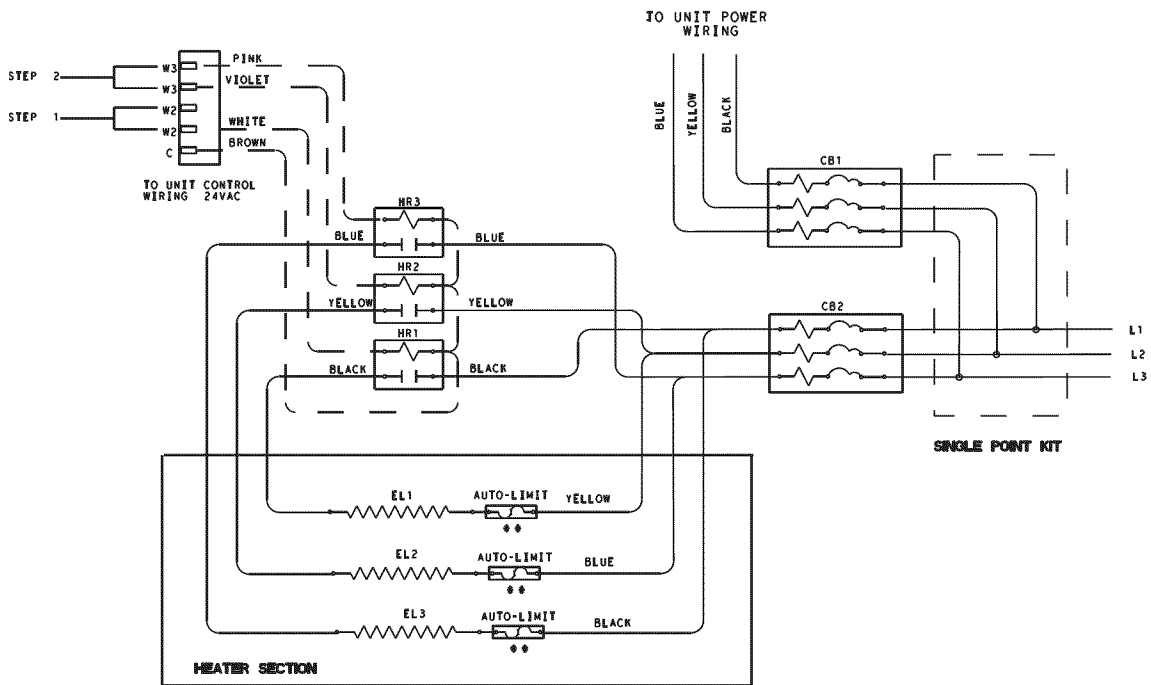

Fig. 18 - Three-Phase Accessory Electric Heater Wiring

A06327

**Table 4 – Dry Coil Air Delivery* Horizontal Discharge
(Deduct 10 percent for 208 Volt Operation)**

230 VOLT HORIZONTAL DISCHARGE												
UNIT SIZE	SPEED TAP	AIR DELIVERY	EXTERNAL STATIC PRESSURE (IN. WC)									
			0.1	0.2	0.3	0.4	0.5	0.6	0.7	0.8	0.9	1.0
024	1	Watts	—	99	100	118	130	142	—	—	—	—
		CFM	—	848	793	757	698	632	—	—	—	—
	2	Watts	—	—	—	—	—	222	233	244	257	260
		CFM	—	—	—	—	—	970	918	861	795	729
030	2	Watts	—	155	146	157	170	—	—	—	—	—
		CFM	—	1108	995	951	884	—	—	—	—	—
	3	Watts	—	—	—	—	—	261	275	286	291	315
		CFM	—	—	—	—	—	1117	1053	1014	980	877
036	1	Watts	180	166	179	191	204	216	—	—	—	—
		CFM	1344	1215	1172	1136	1095	1051	—	—	—	—
	2	Watts	—	—	—	261	276	290	301	316	329	342
		CFM	—	—	—	1343	1304	1272	1234	1190	1148	1100
042	3	Watts	269	283	305	321	336	349	360	—	—	—
		CFM	1440	1404	1369	1333	1301	1273	1239	—	—	—
	4	Watts	—	—	418	432	450	465	480	490	503	518
		CFM	—	—	1572	1543	1504	1475	1441	1418	1380	1332
048	1	Watts	—	204	209	216	229	236	249	—	—	—
		CFM	—	1129	1087	1027	994	932	881	—	—	—
	2	Watts	—	—	233	245	254	266	276	289	—	—
		CFM	—	—	1164	1122	1066	1025	954	906	—	—
	3	Watts	386	398	409	418	425	435	438	441	451	—
		CFM	1680	1652	1625	1583	1555	1515	1477	1444	1403	—
	4	Watts	—	440	448	457	462	469	477	480	485	486
		CFM	—	1745	1717	1684	1651	1612	1573	1537	1508	1470
060	1	Watts	224	235	251	266	277	291	298	—	—	—
		CFM	1334	1288	1259	1224	1181	1157	1117	—	—	—
	2	Watts	—	—	286	301	311	325	333	344	370	—
		CFM	—	—	1333	1296	1261	1232	1199	1170	1062	—
	3	Watts	608	626	643	660	668	685	697	—	—	—
		CFM	1931	1900	1878	1844	1817	1789	1755	—	—	—
	4	Watts	737	755	770	787	799	817	826	812	782	—
		CFM	2093	2061	2028	2001	1971	1934	1899	1850	1757	—

*Air delivery values are based on operating voltage of 230v, wet coil, without filter or electric heater. Deduct filter and electric heater pressure drops to obtain static pressure available for ducting.

NOTES:

1. Do not operate the unit at a cooling airflow that is less than 350 cfm for each 12,000 Btuh of rated cooling capacity. Evaporator coil frosting may occur at airflows below this point.
2. Dashes indicate portions of table that are beyond the blower motor capacity or are not recommended.

PH3Z

Table 5 – Cooling Charging Chart

SUCTION LINE TEMPERATURE (°F)															
Suction Line Pressure (PSIG)															
OD Temp. (°F)	52	54	56	59	61	64	67	70	73	76	79	82	85	89	92
45	51	55	60	64	69	—	—	—	—	—	—	—	—	—	—
55	—	—	53	57	62	66	70	—	—	—	—	—	—	—	—
65	—	—	—	—	53	57	62	66	71	75	—	—	—	—	—
75	—	—	—	—	—	—	—	56	61	66	71	76	—	—	—
85	—	—	—	—	—	—	—	—	53	58	63	67	72	—	—
95	—	—	—	—	—	—	—	—	—	50	54	58	62	66	—
105	—	—	—	—	—	—	—	—	—	—	50	53	57	60	64
115	—	—	—	—	—	—	—	—	—	—	49	52	55	58	61
125	—	—	—	—	—	—	—	—	—	—	—	50	53	56	59

SUCTION LINE TEMPERATURE (°C)															
Suction Line Pressure (kPa)															
OD Temp. (°C)	361	370	387	405	423	442	462	482	502	523	544	566	589	612	636
7	11	13	15	18	21	—	—	—	—	—	—	—	—	—	—
13	—	—	12	14	16	19	21	—	—	—	—	—	—	—	—
18	—	—	—	—	12	14	17	19	21	24	—	—	—	—	—
24	—	—	—	—	—	—	—	13	16	19	22	24	—	—	—
29	—	—	—	—	—	—	—	—	12	14	17	20	22	—	—
35	—	—	—	—	—	—	—	—	—	10	12	14	17	19	—
41	—	—	—	—	—	—	—	—	—	—	10	12	14	16	18
46	—	—	—	—	—	—	—	—	—	—	9	11	13	14	16
52	—	—	—	—	—	—	—	—	—	—	—	10	11	13	15

PHSZ

MAINTENANCE

To ensure continuing high performance, and to minimize the possibility of premature equipment failure, periodic maintenance must be performed on this equipment. This unit should be inspected at least once each year by a qualified service person. To troubleshoot unit, refer to Troubleshooting Chart in back of book.

NOTE TO EQUIPMENT OWNER: Consult your local dealer about the availability of a maintenance contract.

⚠ WARNING

PERSONAL INJURY AND UNIT DAMAGE HAZARD

Failure to follow this warning could result in personal injury or death and possible unit component damage.

The ability to properly perform maintenance on this equipment requires certain expertise, mechanical skills, tools and equipment. If you do not possess these, do not attempt to perform any maintenance on this equipment, other than those procedures recommended in the Owner's Manual.

The minimum maintenance requirements for this equipment are as follows:

1. Inspect air filter(s) each month. Clean or replace when necessary.
2. Inspect indoor coil, drain pan, and condensate drain each cooling season for cleanliness. Clean when necessary.
3. Inspect blower motor and wheel for cleanliness each cooling season. Clean when necessary.
4. Check electrical connections for tightness and controls for proper operation each cooling season. Service when necessary.
5. Ensure electric wires are not in contact with refrigerant tubing or sharp metal edges.

⚠ WARNING

ELECTRICAL SHOCK HAZARD

Failure to follow these warnings could result in personal injury or death:

1. Turn off electrical power to the unit before performing any maintenance or service on this unit.
2. Use extreme caution when removing panels and parts.
3. Never place anything combustible either on or in contact with the unit.

Step 1 — Air Filter

IMPORTANT: Never operate the unit without a suitable air filter in the return-air duct system. Always replace the filter with the same dimensional size and type as originally installed. See Table 1 for recommended filter sizes.

Inspect air filter(s) at least once each month and replace (throwaway-type) or clean (cleanable-type) at least twice during each cooling season and twice during the heating season, or whenever the filter becomes clogged with dust and lint.

Step 2 — Unit Top Removal

NOTE: When performing maintenance or service procedures that require removal of the unit top, be sure to perform all of the routine maintenance procedures that require top removal, including coil inspection and cleaning, and condensate drain pan inspection and cleaning.

⚠ WARNING

ELECTRICAL SHOCK HAZARD

Failure to follow this warning could result in personal injury or death.

Disconnect and tag electrical power to the unit before removing top.

Only qualified service personnel should perform maintenance and service procedures that require unit top removal.

Refer to the following top removal procedures:

1. Remove screws on unit top cover surface. (Save all screws.)
2. Remove screws on unit top cover flange. (Save all screws.)
3. Lift top from unit carefully. Set top on edge and make sure that top is supported by unit side that is opposite duct (or plenum) side.
4. Carefully replace and secure unit top to unit, using screws removed in Steps 1 and 2, when maintenance and/or service procedures are completed.

Step 3 — Indoor Blower and Motor

For longer life, operating economy, and continuing efficiency, clean accumulated dirt and grease from the blower wheel and motor annually.

PH3Z

⚠ WARNING

ELECTRICAL SHOCK HAZARD

Failure to follow this warning could result in personal injury or death.

Disconnect and tag electrical power to the unit before cleaning and lubricating the blower motor and wheel.

To clean the blower wheel:

1. Remove the blower housing:
 - a. Remove the screws on the external side of the duct panel that fasten the housing to the duct panel assembly.
 - b. Remove the side access panel and unscrew the mounting bracket that fastens the blower housing to the internal partition panel for the control box assembly.
 - c. Make sure that the blower housing is supported by hand before completely removing the mounting bracket.
 - d. Slide the blower housing from the rails of the duct panel and place it outside the unit.
2. Remove the blower wheel from the housing:
 - a. Loosen the set screw which secures the wheel to the motor shaft.
 - b. Loosen the three mounting legs of the motor by removing the bolts that fasten the mounting legs to the housing.
 - c. Slide out the motor assembly (motor, belly band and the 3 mounting legs) from the hub of the wheel.
 - d. Remove the filler panel at the discharge end of the blower housing by removing the two screws that fasten it to the housing.
 - e. Remove the wheel from the housing.
3. Remove the caked on dirt from the wheel and the motor using a brush.
4. Remove lint and dirt accumulations from the wheel and housing with a vacuum cleaner, using a soft brush attachment.
5. Remove grease and oil with a mild solvent.
6. Reassemble
 - a. Slip the wheel back in the housing with the hub set screw parented in the correct direction.
 - b. Install the filler panel.
 - c. Reinsert the motor assembly in the wheel hub and align the mounting legs with the housing mounting hold locations.
 - d. Tighten the mounting bolts to fasten the motor assembly with the housing.
 - e. Center the wheel in the housing by sliding it, align the flat end of the shaft with the set screw and tighten the set screw.
 - f. Slide back the blower housing into the mounting rails in the duct panel and install the mounting bracket back in its position.
 - g. Install the screws on the external side of the duct panel to fasten duct panel with the housing.
 - h. Replace the side access panel.

Table 6 – Wet Coil Pressure Drop

UNIT SIZE	STANDARD CFM (S.C.F.M.)														
	600	700	800	900	1000	1100	1200	1300	1400	1500	1600	1700	1800	1900	2000
024	.027	.034	.040	.047	.053	-	-	-	-	-	-	-	-	-	-
030	-	.036	.042	.050	.055	.063	.072	.081	-	-	-	-	-	-	-
036	-	-	-	.050	.055	.063	.072	.081	.090	.097	-	-	-	-	-
042	-	-	-	-	.042	.049	.052	.059	.065	.071	.078	.085	.091	-	-
048	-	-	-	-	-	-	.072	.081	.090	.097	.108	.120	.129	.139	-
060	-	-	-	-	-	-	-	-	-	.071	.078	.085	.091	.098	.114

Table 7 – Filter Pressure Drop (in. wc)

UNIT SIZE	FILTER SIZE in. (mm)	CFM																		
		500	600	700	800	900	1000	1100	1200	1300	1400	1500	1600	1700	1800	1900	2000	2100	2200	2300
024-036	24 x 24 610 x 610	0.06	0.07	0.08	0.08	0.09	0.09	0.09	0.10	0.11	0.12	0.14	0.15	—	—	—	—	—	—	—
042-060	30 x 30 762 x 762	—	—	—	—	—	—	—	—	0.08	0.09	0.10	0.11	0.12	0.13	0.14	0.15	0.16	0.17	0.18

Table 8 – Accessory Electric Heat Pressure Drop (in. wc)

HEATER kW	CFM								
	600	800	1000	1200	1400	1600	1800	2000	2200
5-20	0.06	0.08	0.10	0.13	0.15	0.18	0.20	0.23	0.25

Step 4 — Outdoor Coil, Indoor Coil, and Condensate Drain Pan

Inspect the condenser coil, evaporator coil, and condensate drain pan at least once each year.

The coils are easily cleaned when dry; therefore, inspect and clean the coils either before or after each cooling season. Remove all obstructions, including weeds and shrubs, that interfere with the airflow through the condenser coil.

Straighten bent fins with a fin comb. If coated with dirt or lint, clean the coils with a vacuum cleaner, using the soft brush attachment. Be careful not to bend the fins. If coated with oil or grease, clean the coils with a mild detergent and water solution. Rinse coils with clear water, using a garden hose. Be careful not to splash water on motors, insulation, wiring, or air filter(s). For best results, spray condenser coil fins from inside to outside the unit. On units with an outer and inner condenser coil, be sure to clean between the coils. Be sure to flush all dirt and debris from the unit base.

Inspect the drain pan and condensate drain line when inspecting the coils. Clean the drain pan and condensate drain by removing all foreign matter from the pan. Flush the pan and drain trough with clear water. Do not splash water on the insulation, motor, wiring, or air filter(s). If the drain trough is restricted, clear it with a “plumbers snake” or similar probe device.

Step 5 — Outdoor Fan

⚠ CAUTION

UNIT OPERATION HAZARD

Failure to follow this caution may result in damage to unit components.

Keep the condenser fan free from all obstructions to ensure proper cooling operation. Never place articles on top of unit.

1. Shut off unit power supply and install lockout tag.
2. Remove outdoor-fan assembly (grille, motor, motor cover, and fan) by removing screws and flipping assembly onto unit top cover.
3. Loosen fan hub setscrews.
4. Adjust fan height as shown in Fig. 19.
5. Tighten setscrews.
6. Replace outdoor-fan assembly.

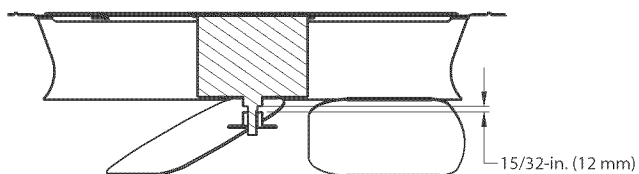

A08004

Fig. 19 - Outdoor Fan Adjustment

Step 6 — Electrical Controls and Wiring

Inspect and check the electrical controls and wiring annually. Be sure to turn off the electrical power to the unit.

Remove access panel to locate all the electrical controls and wiring. Check all electrical connections for tightness. Tighten all screw connections. If any smoky or burned connections are noticed, disassemble the connection, clean all the parts, re-strip the wire end and reassemble the connection properly and securely.

Check to ensure no wires are touching refrigerant tubing or sharp sheet metal edges. Move and secure wires to isolate from tubing and sheet metal edges.

After inspecting the electrical controls and wiring, replace all the panels. Start the unit, and observe at least one complete cooling cycle to ensure proper operation. If discrepancies are observed in operating cycle, or if a suspected malfunction has occurred, check each electrical component with the proper electrical instrumentation. Refer to the unit wiring label when making these checks.

Step 7 — Refrigerant Circuit

Inspect all refrigerant tubing connections and the unit base for oil accumulation annually. Detecting oil generally indicates a refrigerant leak.

If oil is detected or if low performance is suspected, leak test all refrigerant tubing using an electronic leak detector, or liquid-soap solution. If a refrigerant leak is detected, refer to Check for Refrigerant Leaks section.

If no refrigerant leaks are found and low performance is suspected, refer to Checking and Adjusting Refrigerant Charge section.

Step 8 — Indoor Airflow

The heating and/or cooling airflow does not require checking unless improper performance is suspected. If a problem exists, be sure that all supply- and return-air grilles are open and free from obstructions, and that the air filter is clean.

Step 9 — Metering Devices

Refrigerant cooling metering device is an AccuRater (024-042) or TXV (048 and 060) located upstream of the indoor coil distributor assembly. Refrigerant heating mode metering device is an AccuRater located upstream of the outdoor coil distributor assembly.

Step 10 — Liquid Line Strainers

The liquid line strainers (to protect metering devices) are made of wire mesh and are located in the liquid lines on the inlet side of the metering devices.

Step 11 — High Flow Valves

High flow valves are located on the compressor hot gas and suction tubes. Large black plastic caps distinguish these valves with O-rings located inside the caps. These valves can not be accessed for service in the field. Ensure the plastic caps are in place and tight or the possibility of refrigerant leakage could occur.

TROUBLESHOOTING

Refer to the Troubleshooting Chart (Table 9) for troubleshooting information.

START-UP CHECKLIST

Use the Start-Up Checklist at the back of this manual.

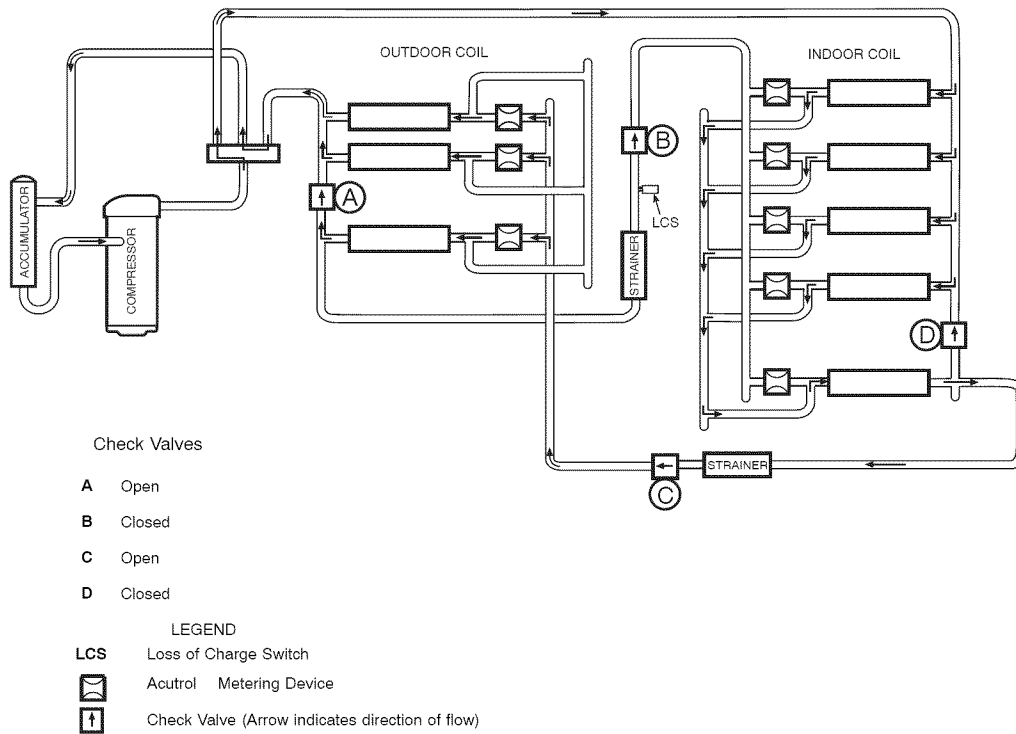

HEATING CYCLE

1. Hot gas from compressor flows through the 4-way valve and is directed to the cooling liquid line check valve. It is then condensed and subcooled through converging circuits and out to the strainer and the check valve in the heating liquid line.
2. The refrigerant then feeds the outdoor coil through the Acutrol metering device on each circuit.
3. Each circuit evaporates the refrigerant and the circuits are combined in the outdoor header with some of the circuits flowing through the check valve.
4. The refrigerant then flows through the 4-way valve, accumulator, and back to the compressor.

Fig. 20 - Typical Heat Pump Operation, Heating Mode

C95045

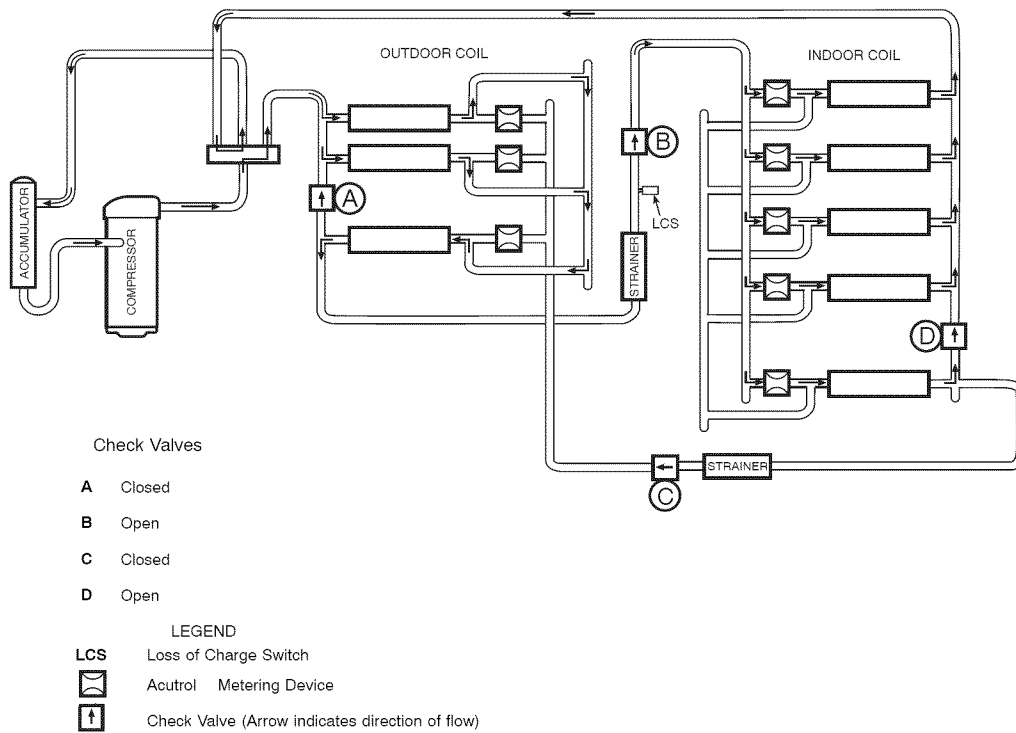

COOLING CYCLE

1. Hot gas from compressor flows through the 4-way valve and is directed to the heating liquid line check valve. It is then condensed and subcooled through converging circuits. Refrigerant leaves the outdoor coil by way of the strainer and the check valve in the cooling liquid line.
2. The refrigerant then feeds the indoor coil through the Acutrol metering device on each circuit.
3. Each circuit evaporates the refrigerant and the circuits are combined in the indoor coil header with some of the circuits flowing through the check valve.
4. The refrigerant then flows through the 4-way valve, accumulator, and back to the compressor.

Fig. 21 - Typical Heat Pump Operation, Cooling Mode

C95044

Table 9 – Troubleshooting Chart

SYMPTOM	CAUSE	REMEDY
Compressor and outdoor fan will not start	Power failure	Call power company
	Fuse blown or circuit breaker tripped	Replace fuse or reset circuit breaker
	Defective contactor, transformer, control relay, or high-pressure, loss-of-charge or low-pressure switch	Replace component
	Insufficient line voltage	Determine cause and correct
	Incorrect or faulty wiring	Check wiring diagram and rewire correctly
	Thermostat setting too low/too high	Reset Thermostat setting
Compressor will not start but condenser fan runs	Faulty wiring or circuit Loose connections in compressor	Check wiring and repair or replace
	Compressor motor burned out, seized, or internal overload open	Determine cause Replace compressor
	Defective run capacitor, overload, or PTC (positive temperature coefficient) thermistor	Determine cause and replace
	One leg of 3-phase power dead	Replace fuse or reset circuit breaker Determine cause
	Low input voltage	Determine cause and correct
Three-phase scroll compressor (size 030-060 unit) has a low pressure differential	Scroll compressor is rotating in the wrong direction	Correct the direction of rotation by reversing the 3-phase power leads to the unit
Compressor cycles (other than normally satisfying) cooling/heating calls	Refrigerant overcharge or undercharge	Recover refrigerant, evacuate system, and recharge to capacities shown on rating plate
	Defective compressor	Replace and determine cause
	Insufficient line voltage	Determine cause and correct
	Blocked outdoor coil	Determine cause and correct
	Defective run/start capacitor, overload or start relay	Determine cause and replace
	Faulty outdoor fan motor or capacitor	Replace
	Restriction in refrigerant system	Locate restriction and remove
Compressor operates continuously	Dirty air filter	Replace filter
	Unit undersized for load	Decrease load or increase unit size
	Thermostat temperature set too low	Reset Thermostat setting
	Low refrigerant charge	Locate leak, repair, and recharge
	Air in system	Recover refrigerant, evacuate system, and recharge
	Outdoor coil dirty or restricted	Clean coil or remove restriction
Excessive head pressure	Dirty air filter	Replace filter
	Dirty indoor or outdoor coil	Clean coil
	Refrigerant overcharged	Recover excess refrigerant
	Air in system	Recover refrigerant, evacuate system, and recharge
	Indoor or outdoor air restricted or air short-cycling	Determine cause and correct
Head pressure too low	Low refrigerant charge	Check for leaks, repair and recharge
	Restriction in liquid tube	Remove restriction
Excessive suction pressure	High Heat load	Check for source and eliminate
	Reversing valve hung up or leaking internally	Replace valve
	Refrigerant overcharged	Recover excess refrigerant
	Dirty air filter	Replace filter
Suction pressure too low	Low refrigerant charge	Check for leaks, repair and recharge
	Metering device or low side restricted	Remove source of restriction
	Insufficient coil airflow	Check filter—replace if necessary
	Temperature too low in conditioned area	Reset Thermostat setting
	Outdoor ambient below 55°F (13°C)	Install low-ambient kit
	Filter drier restricted	Replace

PH3Z

START-UP CHECKLIST (REMOVE AND STORE IN JOB FILE)

I. PRELIMINARY INFORMATION

Model No
Serial No
Date
Technician
Customer Information(Name/Address)

II. PRE-START-UP

- Verify that all packing materials have been removed from unit.
- Verify that condensate connection is installed per installation instructions.
- Check all electrical connections and terminals for tightness.
- Check wire proximity to refrigerant tubes and sheet metal edges.
- Check that indoor (indoor) air filter is clean and in place.
- Verify that unit installation is level.
- Check fan wheel propeller for location in housing and setscrew tightness.

III. START-UP

Supply Voltage: L1-L2 _____ L2-L3 _____ L3-L1 _____
Compressor Amps: L1(C) _____ L2(S) _____ L3(R) _____
Indoor Fan Amps: _____ Outdoor Fan Amps: _____

TEMPERATURE-Cooling Mode

Outdoor Air Temperature: _____ DB _____ WB
Return-Air Temperature: _____ DB _____ WB
Cooling Supply Air: _____ DB _____ WB

PRESSURES-Cooling Mode

Refrigerant Suction _____ psig
Suction Line Temp* _____
Refrigerant Discharge _____ psig
Discharge Temp† _____

TEMPERATURE-Heating Mode

Outdoor Air Temperature: _____ DB _____ WB
Return-Air Temperature: _____ DB _____ WB
Cooling Supply Air: _____ DB _____ WB

PRESSURES-Heating Mode

Refrigerant Suction _____ psig
Suction Line Temp* _____
Refrigerant Discharge _____ psig
Discharge Temp† _____
 Verify Refrigerant charge using charging tables

*Measured at suction inlet to compressor
†Measured at liquid line leaving outdoor coil

PH3Z