



# 7021RB

---

## Owner's Manual



# SAFETY RULES



## Safe Operation Practices for Walk-Behind Mowers

**IMPORTANT:** THIS CUTTING MACHINE IS CAPABLE OF AMPUTATING HANDS AND FEET AND THROWING OBJECTS. FAILURE TO OBSERVE THE FOLLOWING SAFETY INSTRUCTIONS COULD RESULT IN SERIOUS INJURY OR DEATH.



Look for this symbol to point out important safety precautions. It means **CAUTION!!! BECOME ALERT!!! YOUR SAFETY IS INVOLVED.**



**CAUTION:** Always disconnect spark plug wire and place wire where it cannot contact spark plug in order to prevent accidental starting when setting up, transporting, adjusting or making repairs.



**WARNING:** Engine exhaust, some of its constituents, and certain vehicle components contain or emit chemicals known to the State of California to cause cancer and birth defects or other reproductive harm.



**WARNING:** Battery posts, terminals and related accessories contain lead and lead compounds, chemicals known to the State of California to cause cancer and birth defects or other reproductive harm. Wash hands after handling.



**CAUTION:** Muffler and other engine parts become extremely hot during operation and remain hot after engine has stopped. To avoid severe burns on contact, stay away from these areas.

### I. GENERAL OPERATION

- Read, understand, and follow all instructions on the machine and in the manual(s) before starting. Be thoroughly familiar with the controls and the proper use of the machine before starting.
- Do not put hands or feet near or under rotating parts. Keep clear of the discharge opening at all times.
- Only allow responsible individuals, who are familiar with the instructions, to operate the machine.
- Clear the area of objects such as rocks, toys, wire, bones, sticks, etc., which could be picked up and thrown by the blade.
- Be sure the area is clear of other people before mowing. Stop machine if anyone enters the area.
- Do not operate the mower when barefoot or wearing open sandals. Always wear substantial foot wear.
- Do not pull mower backwards unless absolutely necessary. Always look down and behind before and while moving backwards.
- Never direct discharged material toward anyone. Avoid discharging material against a wall or obstruction. Material may ricochet back toward the operator. Stop the blade when crossing gravel surfaces.
- Do not operate the mower without proper guards, plates, grass catcher or other safety protective devices in place.
- See manufacturer's instructions for proper operation and installation of accessories. Only use accessories approved by the manufacturer.

- Stop the blade(s) when crossing gravel drives, walks, or roads.
- Stop the engine (motor) whenever you leave the equipment, before cleaning the mower or unclogging the chute.
- Shut the engine (motor) off and wait until the blade comes to complete stop before removing grass catcher.
- Mow only in daylight or good artificial light.
- Do not operate the machine while under the influence of alcohol or drugs.
- Never operate machine in wet grass. Always be sure of your footing; keep a firm hold on the handle and walk; never run.
- Disengage the self-propelled mechanism or drive clutch on mowers so equipped before starting the engine (motor).
- If the equipment should start to vibrate abnormally, stop the engine (motor) and check immediately for the cause. Vibration is generally a warning of trouble.
- Always wear safety goggles or safety glasses with side shields when operating mower.

### II. SLOPE OPERATION

Slopes are a major factor related to slip and fall accidents which can result in severe injury. All slopes require extra caution. If you feel uneasy on a slope, do not mow it.

#### DO:

- Mow across the face of slopes: never up and down. Exercise extreme caution when changing direction on slopes.
- Remove obstacles such as rocks, tree limbs, etc.
- Watch for holes, ruts, or bumps. Tall grass can hide obstacles.

#### DO NOT:

- Do not trim near drop-offs, ditches or embankments. The operator could lose footing or balance.
- Do not trim excessively steep slopes.
- Do not mow on wet grass. Reduced footing could cause slipping.

### III. CHILDREN

Tragic accidents can occur if the operator is not alert to the presence of children. Children are often attracted to the machine and the mowing activity. *Never* assume that children will remain where you last saw them.

- Keep children out of the trimming area and under the watchful care of another responsible adult.
- Be alert and turn machine off if children enter the area.
- Before and while walking backwards, look behind and *down* for small children.
- Never allow children to operate the machine.
- Use extra care when approaching blind corners, shrubs, trees, or other objects that may obscure vision.

### IV. SAFE HANDLING OF GASOLINE

Use extreme care in handling gasoline. Gasoline is extremely flammable and the vapors are explosive.

- Extinguish all cigarettes, cigars, pipes and other sources of ignition.
- Use only an approved container.

- Never remove gas cap or add fuel with the engine running. Allow engine to cool before refueling.
- Never refuel the machine indoors.
- Never store the machine or fuel container where there is an open flame, spark or pilot light such as a water heater or on other appliances.
- Never fill containers inside a vehicle, on a truck or trailer bed with a plastic liner. Always place containers on the ground away from your vehicle before filling.
- Remove gas-powered equipment from the truck or trailer and refuel it on the ground. If this is not possible, then refuel such equipment with a portable container, rather than from a gasoline dispenser nozzle.
- Keep the nozzle in contact with the rim of the fuel tank or container opening at all times until fueling is complete. Do not use a nozzle lock-open device.
- If fuel is spilled on clothing, change clothing immediately.
- Never overfill fuel tank. Replace gas cap and tighten securely.

- (motor) running. Disconnect spark plug wire, and keep wire away from plug to prevent accidental starting.
- Keep nuts and bolts, especially blade attachment bolts, tight and keep equipment in good condition.
- Never tamper with safety devices. Check their proper operation regularly.
- Keep machine free of grass, leaves, or other debris build-up. Clean oil or fuel spillage. Allow machine to cool before storing.
- Stop and inspect the equipment if you strike an object. Repair, if necessary, before restarting.
- Never attempt to make wheel height adjustments while the engine (motor) is running.
- Grass catcher components are subject to wear, damage, and deterioration, which could expose moving parts or allow objects to be thrown. Frequently check components and replace with manufacturer's recommended parts, when necessary.
- Mower blade is sharp and can cut. Wrap the blade or wear gloves, and use extra caution when servicing it.
- Do not change the engine governor setting or over-speed the engine.
- Maintain or replace safety and instruction labels, as necessary.

## V. GENERAL SERVICE

- Never run a machine inside a closed area.
- Never make adjustments or repairs with the engine

**▲WARNING:** This lawn mower is equipped with an internal combustion engine and should not be used on or near any unimproved forest-covered, brush-covered or grass-covered land unless the engine's exhaust system is equipped with a spark arrester meeting applicable local or state laws (if any). If a spark arrester is used, it should be maintained in effective working order by the operator. In the state of California the above is required by law (Section 4442 of the California Public Resources Code). Other states may have similar laws. Federal laws apply on federal lands. A spark arrester for the muffler is available through your nearest authorized service center.

**CONGRATULATIONS** on your purchase of a new lawn mower. It has been designed, engineered and manufactured to give you the best possible dependability and performance.

Should you experience any problem you cannot easily remedy, please contact your nearest authorized service center/department. We have competent, well-trained technicians and the proper tools to service or repair this lawn mower.

Please read and retain this manual. The instructions will enable you to assemble and maintain your lawn mower properly. Always observe the "SAFETY RULES".

SERIAL NUMBER: \_\_\_\_\_

DATE OF PURCHASE: \_\_\_\_\_

THE MODEL AND SERIAL NUMBERS WILL BE FOUND ON A DECAL ATTACHED TO THE REAR OF THE LAWN MOWER HOUSING.

YOU SHOULD RECORD BOTH SERIAL NUMBER AND DATE OF PURCHASE AND KEEP IN A SAFE PLACE FOR FUTURE REFERENCE.

## PRODUCT SPECIFICATIONS

Gasoline Capacity and Type:	1.0 Quarts (Unleaded Regular Only)
Oil Type (API SG-SL):	SAE 30 (above 0°C / 32°F) SAE 10W-30 (below 0°C / 32°F)
Oil Capacity:	18.5 Ounces
Spark Plug:	NGK BPR6ES (Gap: .030")
Valve Clearance: (± 0.04 mm)	Intake: 0.015 mm Exhaust: 0.020 mm
Blade Bolt Torque:	35-40 ft. lbs.

## CUSTOMER RESPONSIBILITIES

- Read and observe the safety rules.
- Follow a regular schedule in maintaining, caring for and using your lawn mower.
- Follow the instructions under "Maintenance" and "Storage" sections of this owner's manual.

# TABLE OF CONTENTS

SAFETY RULES .....	2-3
PRODUCT SPECIFICATIONS .....	3
CUSTOMER RESPONSIBILITIES .....	3
ASSEMBLY .....	4
OPERATION .....	5-10
MAINTENANCE SCHEDULE .....	11

MAINTENANCE .....	11-13
SERVICE AND ADJUSTMENTS .....	14
STORAGE .....	14-15
TROUBLESHOOTING .....	16
WARRANTY .....	18

# ASSEMBLY

Read these instructions and this manual in its entirety before you attempt to assemble or operate your new lawn mower.

**IMPORTANT:** THIS LAWN MOWER IS SHIPPED WITHOUT OIL OR GASOLINE IN THE ENGINE.

Your new lawn mower has been assembled at the factory with the exception of those parts left unassembled for shipping purposes. All parts such as nuts, washers, bolts, etc., necessary to complete the assembly have been placed in the parts bag. To ensure safe and proper operation of your lawn mower, all parts and hardware you assemble must be tightened securely. Use the correct tools as necessary to ensure proper tightness.

## TO REMOVE LAWN MOWER FROM CARTON

1. Remove loose parts included with mower.
2. Cut down two end corners of carton and lay end panel down flat.
3. Remove all packing materials except padding between upper and lower handle and padding holding operator presence control bar to upper handle.
4. Roll lawn mower out of carton and check carton thoroughly for additional loose parts.

## HOW TO SET UP YOUR LAWN MOWER

### TO UNFOLD HANDLE (See Figs. 1 & 2)

**IMPORTANT:** UNFOLD HANDLE CAREFULLY SO AS NOT TO PINCH OR DAMAGE CONTROL CABLES.

1. Raise lower handle section to operating position and squeeze the bottom ends of lower handle towards each other until the pin in handle can be inserted into one of the three height adjustment holes.
2. Remove protective padding, raise upper handle section into place on lower handle and tighten both handle knobs.
3. Remove any packing material from around control bar.

Your handles may be adjusted for your mowing comfort. Refer to "ADJUST HANDLE" in the Service and Adjustments section of this manual.

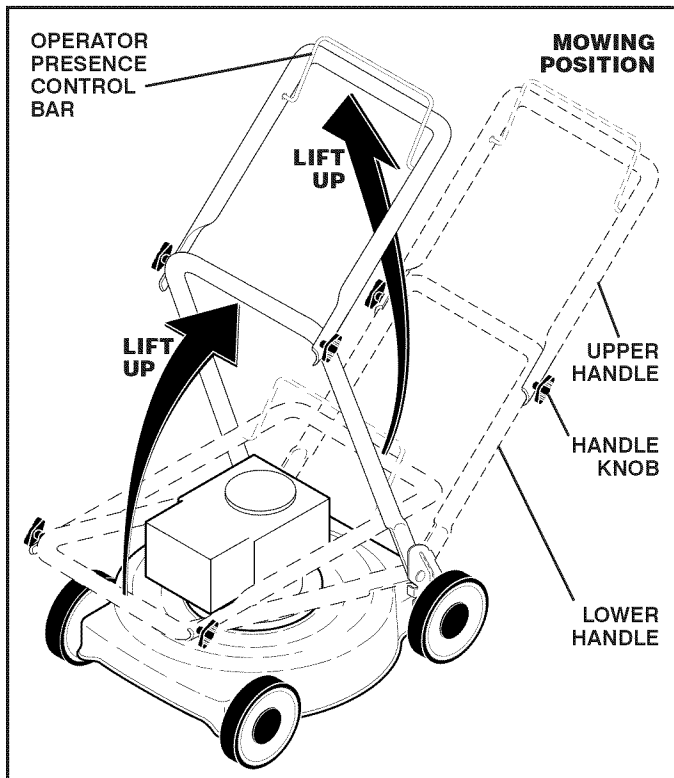

FIG. 1

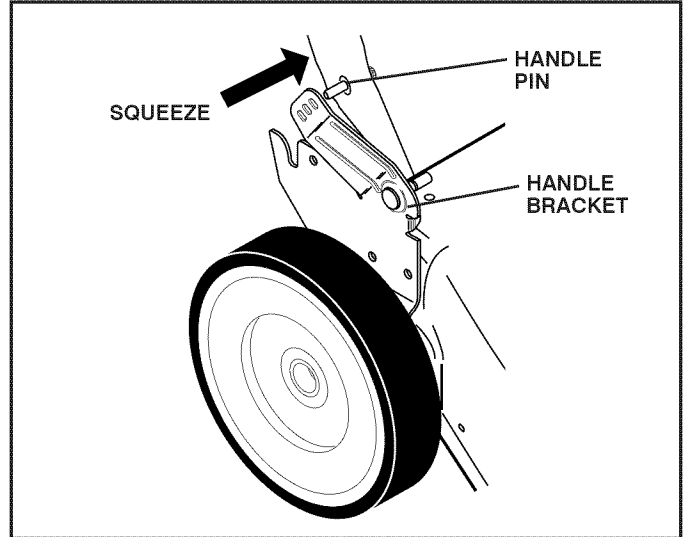

FIG. 2

### TO ASSEMBLE GRASS CATCHER (See Fig. 3)

1. Put grass catcher frame into grass bag with rigid part of bag on the bottom. Make sure the frame handle is outside of the bag top.
2. Slip vinyl bindings over frame.

**NOTE:** If vinyl bindings are too stiff, hold them in warm water for a few minutes. If bag gets wet, let it dry before using.

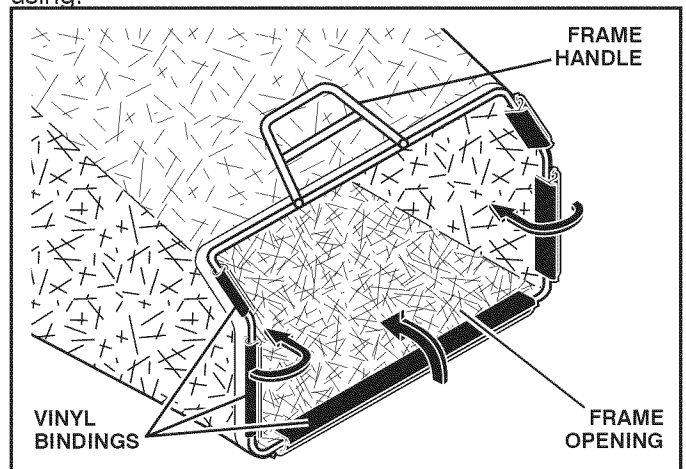

FIG. 3

### TO INSTALL ATTACHMENTS

Your lawn mower was shipped ready to be used as a mulcher. To convert mower to bagging or discharging, see "TO CONVERT MOWER" in the Operation section of this manual.

# OPERATION

## KNOW YOUR LAWN MOWER

READ THIS OWNER'S MANUAL AND SAFETY RULES BEFORE OPERATING YOUR LAWN MOWER.

Compare the illustrations with your lawn mower to familiarize yourself with the location of various controls and adjustments. Save this manual for future reference.

These symbols may appear on your lawn mower or in literature supplied with the product. Learn and understand their meaning.

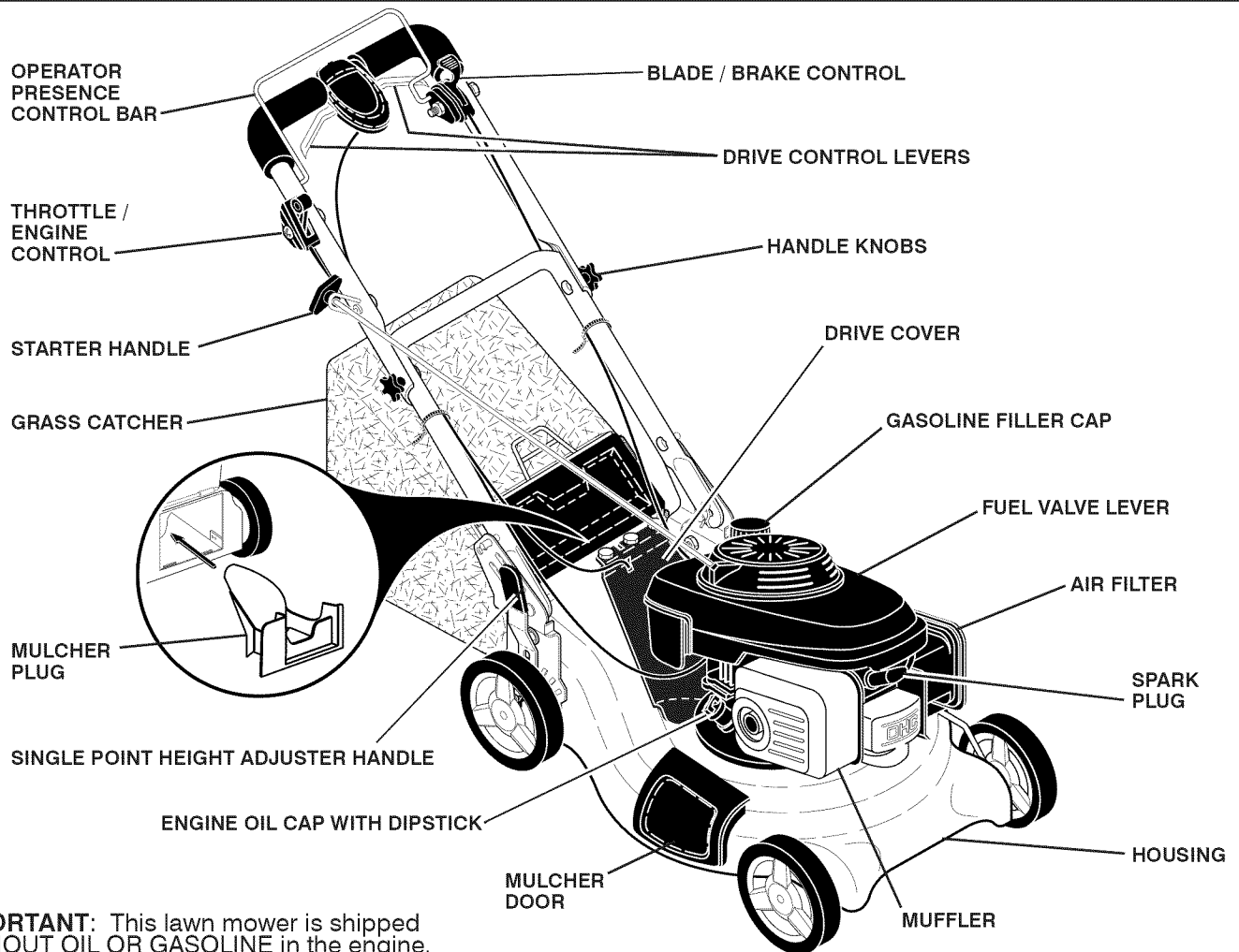
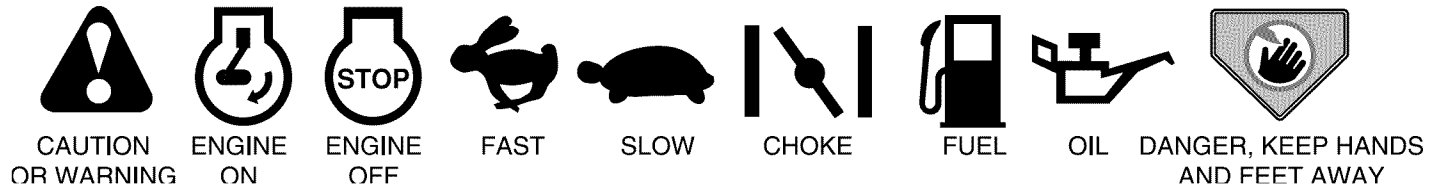

**IMPORTANT:** This lawn mower is shipped WITHOUT OIL OR GASOLINE in the engine.

## MEETS CPSC SAFETY REQUIREMENTS

Our rotary walk-behind power lawn mowers conform to the safety standards of the American National Standards Institute and the U.S. Consumer Product Safety Commission.

**OPERATOR PRESENCE CONTROL BAR** – must be held down to the handle to start the blade. Release to stop the blade.

**DRIVE CONTROL LEVERS** – used to engage power-propelled forward motion lawn mower.

**BLADE / BRAKE CONTROL** – used to engage the blade after the engine is started.

**SINGLE POINT HEIGHT ADJUSTER** – used to adjust cutting height of lawn mower.

**THROTTLE / ENGINE CONTROL** – used for starting and stopping the engine; and allows you to select either FAST or SLOW engine speed.

**STARTER HANDLE** – used for starting the engine.

**MULCHER DOOR** – allows conversion to discharge or bagging operation.

**MULCHER PLUG** – located at the discharge opening, must be removed when converting to bagging operation.

# OPERATION



The operation of any lawn mower can result in foreign objects thrown into the eyes, which can result in severe eye damage. Always wear safety glasses or eye shields while operating your lawn mower or performing any adjustments or repairs. We recommend standard safety glasses or a wide vision safety mask over spectacles.

## HOW TO USE YOUR LAWN MOWER

### THROTTLE / ENGINE CONTROL (See Fig. 4)

The engine is controlled by a throttle control located on the side of the upper handle. CHOKE position is for starting a cold engine; FAST position is for starting a warm engine, normal cutting, trimming and better grass bagging; SLOW position is for light cutting, trimming and fuel economy, and STOP position is for stopping the engine.

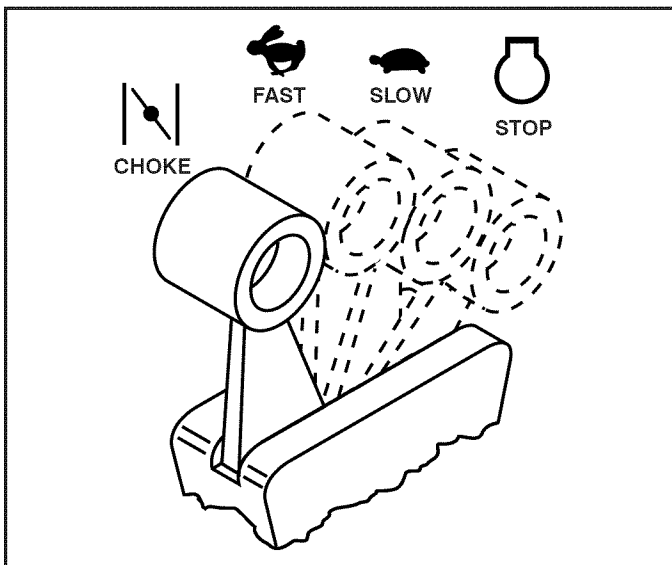

FIG. 4

### BLADE CONTROL (See Fig. 5)



**CAUTION:** When the blade control is engaged, the blade turns.

- To start the blade, hold the operator presence control bar down to the handle and push the blade/brake control lever forward until it latches. To stop the blade, release the operator presence control bar. Do not pull the blade/brake lever rearward with the operator presence control bar down against the handle. Allow a cold engine to warm up in high idle position for one minute before engaging the blade.

**NOTE:** It is normal to hear the belt slip as the blade is engaged and comes up to speed.

- Do not start the blade in uncut grass. Move the mower out of uncut grass before starting the blade.



**CAUTION:** Federal regulations require this blade/brake control to minimize the risk of blade contact injury. Do not under any circumstances attempt to defeat the function of this control.

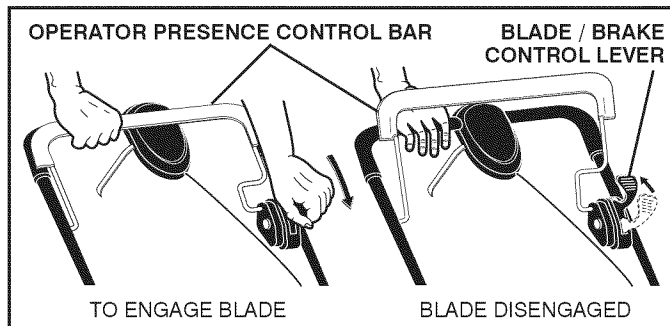

FIG. 5

# OPERATION

## DRIVE CONTROL (See Fig. 6)

- Self-propelling is controlled by holding the operator presence control bar down to the handle and pulling either drive control lever rearward to the handle. The further toward the handle a lever is pulled, the faster the unit will travel.
- Forward motion will stop when either the operator presence control bar or a drive control lever are released. To stop forward motion without stopping blade, release a drive control lever only. Hold operator presence control bar down against handle to continue mowing without self-propelling.

**NOTE:** If after releasing the drive control the mower will not roll backwards, push the mower forward slightly to disengage drive wheels.

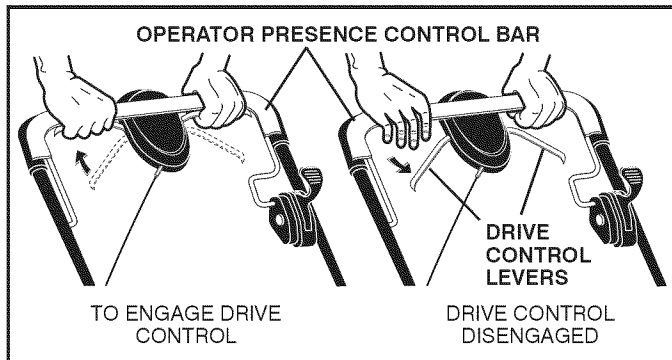

FIG. 6

## DRIVE CONTROL ADJUSTMENT (See Fig. 7)

Over time, the drive control system may become “loose”, resulting in decreased speed. There is a turnbuckle on the drive control housing to increase tension on the drive cable. Proceed as follows:

1. Turn unit off and disconnect spark plug wire from spark plug.
2. Rotate turnbuckle on drive control to increase drive speed.
3. Operate mower to test drive speed. Readjust as required.
4. If condition fails to improve after the above steps (forward speed remains the same), your drive belt is worn and should be replaced.

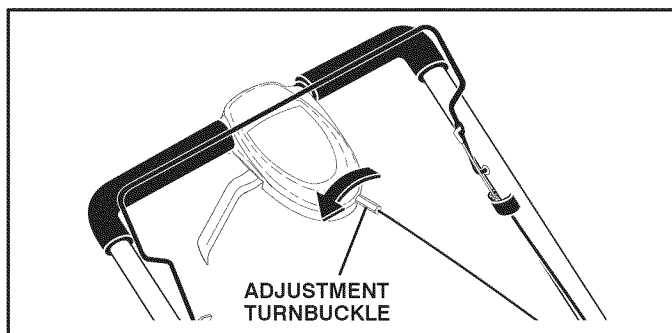

FIG. 7

## TO ADJUST CUTTING HEIGHT (See Fig. 8)

All four wheels are adjusted by a single lever.

- Pull adjuster lever toward wheel. To raise mower, move lever forward to desired position. To lower mower, move the lever toward the rear.

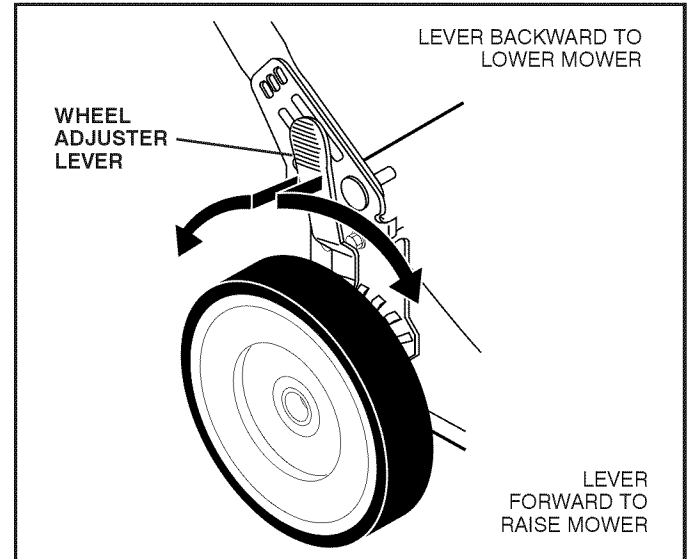

FIG. 8

## TO ATTACH GRASS CATCHER (See Fig. 9)

1. Lift the rear door of the lawn mower and place the grass catcher frame side hooks onto the door pivot pins.
2. The grass catcher is secured to the lawn mower housing when the rear door is lowered onto the grass catcher frame.



**CAUTION:** Do not run your lawn mower without mulcher plug or approved grass catcher in place. Never attempt to operate the lawn mower with the rear door removed or propped open.

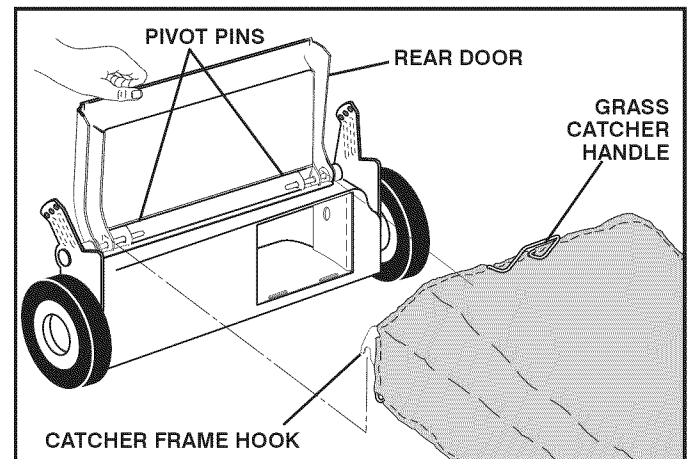

FIG. 9

# OPERATION

## TO EMPTY GRASS CATCHER (See Fig. 10)

1. Lift up on grass catcher using the frame handle.
2. Remove grass catcher with clippings from under lawn mower handle.
3. Empty clippings from bag.

**NOTE:** Do not drag the bag when emptying; it will cause unnecessary wear.

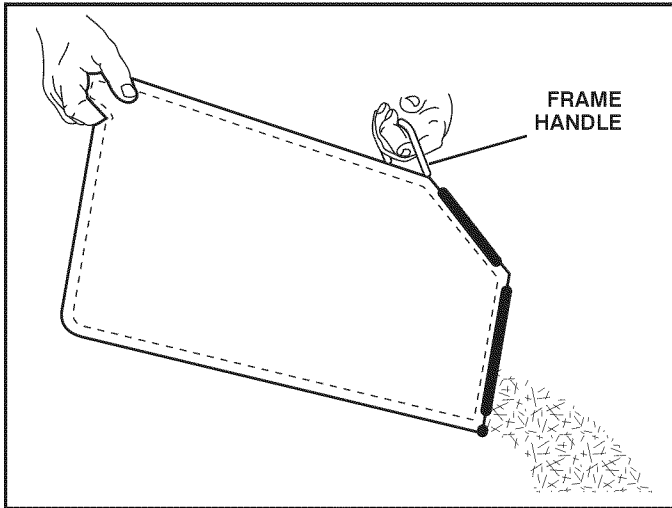

FIG. 10

## TO CONVERT MOWER

Your lawn mower was shipped ready to be used as a mulcher. To convert to bagging or discharging:

### REAR BAGGING (See Fig. 11)

- Open rear door and remove mulcher plug. Store mulcher plug in a safe place.
- You can now install the grass catcher.
- To convert to mulching or discharging operation, install mulcher plug into rear discharge opening of mower.

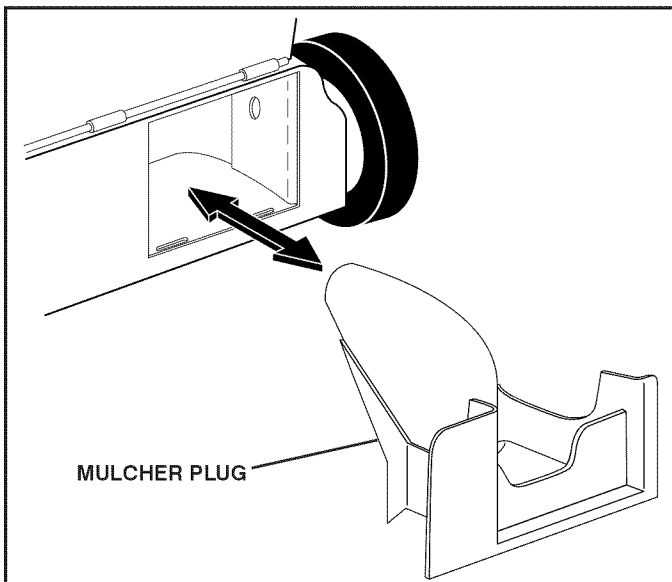

FIG. 11

### SIDE DISCHARGING (See Fig. 12)

- Mulcher plug must be installed into rear discharge opening of mower.
- Open mulcher door and install discharge deflector under door as shown.
- Mower is now ready for discharging operation.
- To convert to mulching or bagging operation, discharge deflector must be removed and mulcher door closed.

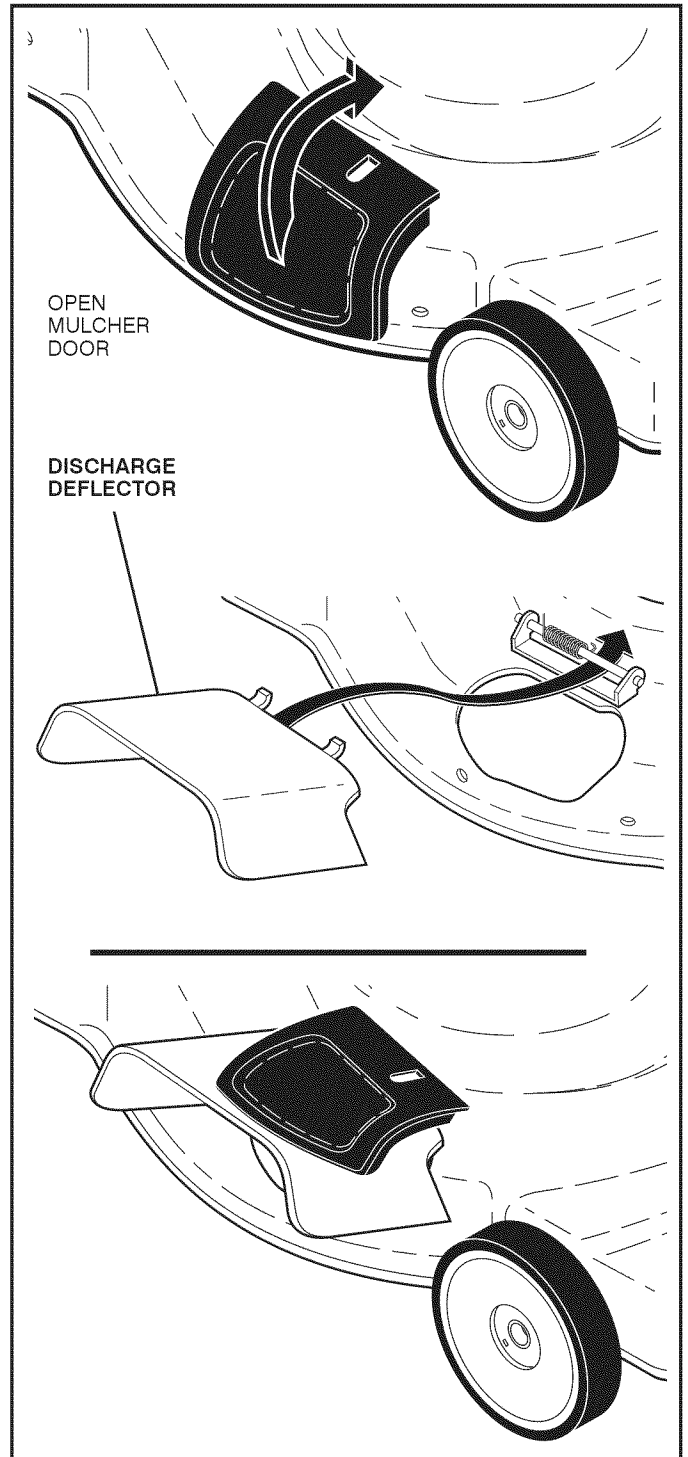

FIG. 12



# OPERATION

## SIMPLE STEPS TO REMEMBER WHEN CONVERTING YOUR LAWN MOWER

### FOR MULCHING -

1. Rear mulcher plug installed.
2. Mulcher door closed.

### FOR REAR BAGGING -

1. Rear mulcher plug removed.
2. Grass catcher installed.
3. Mulcher door closed.

### FOR SIDE DISCHARGING -

1. Rear mulcher plug installed.
2. Discharge deflector installed.



**CAUTION:** Do not run your lawn mower without mulcher plug or approved grass catcher in place. Never attempt to operate the lawn mower with the rear door removed or propped open.

## BEFORE STARTING ENGINE

### ADD OIL (See Fig. 13)

Your lawnmower is shipped without oil in the engine. For type and grade of oil to use, see "ENGINE" in the Maintenance section of this manual.



**CAUTION:** DO NOT overfill engine with oil, or it will smoke on startup.

1. Be sure lawnmower is level.
2. Remove oil fill cap/dipstick from oil fill spout.
3. You receive a container of oil with the unit. Slowly pour the entire container down the oil fill spout into the engine.
4. Insert and tighten oil fill cap/dipstick.

### IMPORTANT:

- Check oil level before each use. Add oil if needed. Fill to full line on dipstick.
- Change the oil after every 25 hours of operation or each season. You may need to change the oil more often under dusty, dirty conditions. See "TO CHANGE ENGINE OIL" in the Maintenance section of this manual.

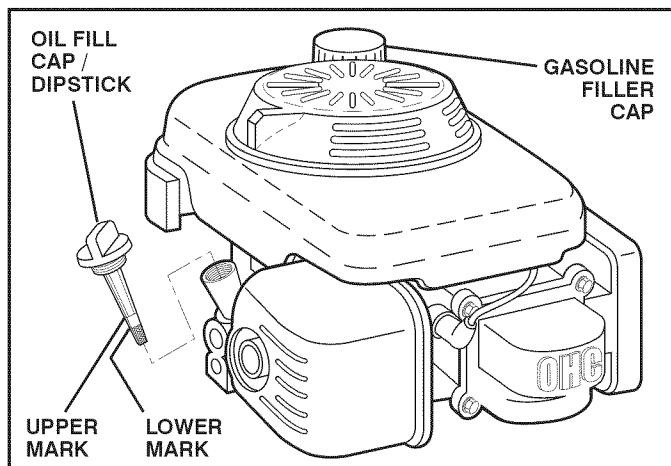

FIG. 13

### ADD GASOLINE (See Fig. 13)

- Fill fuel tank to bottom of tank filler neck. Do not overfill. Use fresh, clean, regular unleaded gasoline with a minimum of 87 octane. Do not mix oil with gasoline. Purchase fuel in quantities that can be used within 30 days to assure fuel freshness.

**CAUTION:** Wipe off any spilled oil or fuel. Do not store, spill or use gasoline near an open flame.



Alcohol blended fuels (called gasohol or using ethanol or methanol) can attract moisture which leads to separation and formation of acids during storage. Acidic gas can damage the fuel system of an engine while in storage. To avoid engine problems, the fuel system should be emptied before storage of 30 days or longer. Empty the gas tank, start the engine and let it run until the fuel lines and carburetor are empty. Use fresh fuel next season. See Storage Instructions for additional information. Never use engine or carburetor cleaner products in the fuel tank or permanent damage may occur.

# OPERATION

## TO STOP ENGINE

- To stop engine, move throttle control lever to STOP position. Wait until blade and all moving parts have stopped and turn fuel valve to OFF position if you do not intend to restart the engine soon.

## TO START ENGINE (See Fig. 14)

**NOTE:** Due to protective coatings on the engine, a small amount of smoke may be present during the initial use of the product and should be considered normal.

1. Be sure fuel valve is in the ON position.
  2. To start a cold engine, move handle mounted throttle/choke control lever to CHOKE position.
  3. Pull starter handle quickly. Do not allow starter rope to snap back.
  4. Slowly move throttle control lever to FAST position after engine starts.
- To start a warm engine, move throttle control lever to FAST position, then follow steps above.

**NOTE:** Allow a cold engine to warm up for one minute before starting the blade. See "BLADE CONTROL" in this section of this manual.

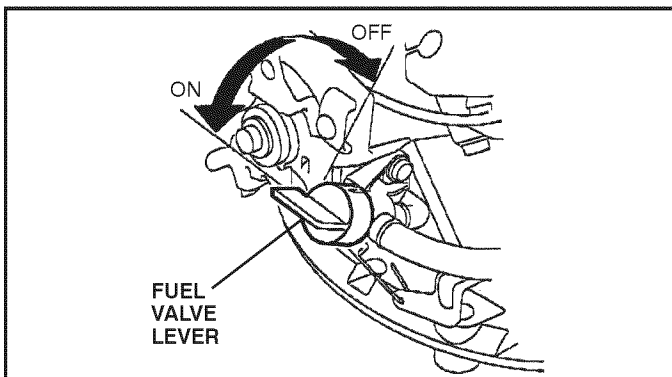

FIG. 14

## MOWING TIPS



**CAUTION:** Do not use de-thatcher blade attachments. Such attachments are hazardous, will damage your mower and could void your warranty.

- Under certain conditions, such as very tall grass, it may be necessary to raise the height of cut to reduce pushing effort and to keep from overloading the engine and leaving clumps of grass clippings. It may also be necessary to reduce ground speed and/or run the lawn mower over the area a second time.
- For extremely heavy cutting, reduce the width of cut by overlapping previously cut path and mow slowly.
- For better grass bagging and most cutting conditions, the engine speed should be set in the fast position.
- Pores in cloth grass catchers can become filled with dirt and dust with use and catchers will collect less grass. To prevent this, regularly hose catcher off with water and let dry before using.
- Keep top of engine around starter clear and clean of grass clippings and chaff. This will help engine air flow and extend engine life.

## MULCHING MOWING TIPS

**IMPORTANT:** FOR BEST PERFORMANCE, KEEP MOWER HOUSING FREE OF BUILT-UP GRASS AND TRASH. SEE "CLEANING" IN MAINTENANCE SECTION OF THIS MANUAL.

- The special mulching blade will recut the grass clippings many times and reduce them in size so that as they fall onto the lawn they will disperse into the grass and not be noticed. Also, the mulched grass will biodegrade quickly to provide nutrients for the lawn. Always mulch with your highest engine (blade) speed as this will provide the best recutting action of the blades.
- Avoid cutting your lawn when it is wet. Wet grass tends to form clumps and interferes with the mulching action. The best time to mow your lawn is the early afternoon. At this time the grass has dried, yet the newly cut area will not be exposed to direct sunlight.
- For best results, adjust the lawn mower cutting height so that the lawn mower cuts off only the top one-third of the grass blades (See Fig. 15). If the lawn is overgrown it will be necessary to raise the height of cut to reduce pushing effort and to keep from overloading the engine and leaving clumps of mulched grass. For extremely heavy mulching, reduce your width of cut

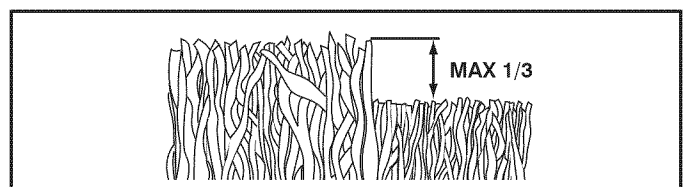

FIG. 15

by overlapping previously cut path and mow slowly.

- Certain types of grass and grass conditions may require that an area be mulched a second time to completely hide the clippings. When doing a second cut, mow across (perpendicular) to the first cut path.
- Change your cutting pattern from week to week. Mow north to south one week then east to west the next week. This will help prevent matting and graining of the lawn.

# MAINTENANCE

MAINTENANCE SCHEDULE		BEFORE EACH USE	AFTER EACH USE	EVERY 10 HOURS	EVERY 25 HOURS OR SEASON	EVERY 100 HOURS	BEFORE STORAGE
LAWN MOWER	Check for Loose Fasteners	✓					✓
	Clean / Inspect Grass Catcher *	✓	✓				✓
	Check Tires	✓					
	Check Drive Wheels ***	✓					
	Clean Lawn Mower ****		✓				✓
ENGINE	Clean under Drive Cover ***			✓			
	Check Drive Belt / Pulleys ***				✓		
	Check / Sharpen / Replace Blade				✓ <sub>3</sub>		
	Lubrication				✓		
	Clean and Recharge Battery **				✓		✓ <sub>4</sub>
ENGINE	Check Engine Oil level	✓ <sub>5</sub>					
	Change Engine Oil				✓ <sub>1,2</sub>		
	Clean Air Filter				✓ <sub>2</sub>		
	Inspect Muffler				✓		
	Replace Spark Plug					✓	
	Replace Air Filter Paper Cartridge					✓ <sub>2</sub>	
Empty fuel system or add Stabilizer						✓	

- \* (if so equipped)
- \*\* Electric-Start mowers
- \*\*\* Power-Propelled mowers
- \*\*\*\* Use a scraper to clean under deck
- 1 - Change more often if operating under a heavy load or in high outdoor temperatures.
- 2 - Service more often if operating in dirty or dusty conditions.
- 3 - Replace blades more often when mowing in sandy soil.
- 4 - Charge 48 hours at end of season.
- 5 - And after each 5 hours of use.

## GENERAL RECOMMENDATIONS

The warranty on this lawn mower does not cover items that have been subjected to operator abuse or negligence. To receive full value from the warranty, operator must maintain mower as instructed in this manual. Some adjustments will need to be made periodically to properly maintain your unit. At least once a season, check to see if you should make any of the adjustments described in the Service and Adjustments section of this manual.

- At least once a year, replace the spark plug, clean or replace air filter element and check blade for wear. A new spark plug and clean/new air filter element assure proper air-fuel mixture and help your engine run better and last longer.
- Follow the maintenance schedule in this manual.

## BEFORE EACH USE

1. Check engine oil level.
2. Check for loose fasteners.

## LUBRICATION

Keep unit well lubricated (See "LUBRICATION CHART").

**IMPORTANT:** DO NOT OIL OR GREASE PLASTIC WHEEL BEARINGS. VISCOUS LUBRICANTS WILL ATTRACT DUST AND DIRT THAT WILL SHORTEN THE LIFE OF THE SELF-LUBRICATING BEARINGS. IF YOU FEEL THEY MUST BE LUBRICATED, USE ONLY A DRY, POWDERED GRAPHITE TYPE LUBRICANT SPARINGLY.

## LUBRICATION CHART

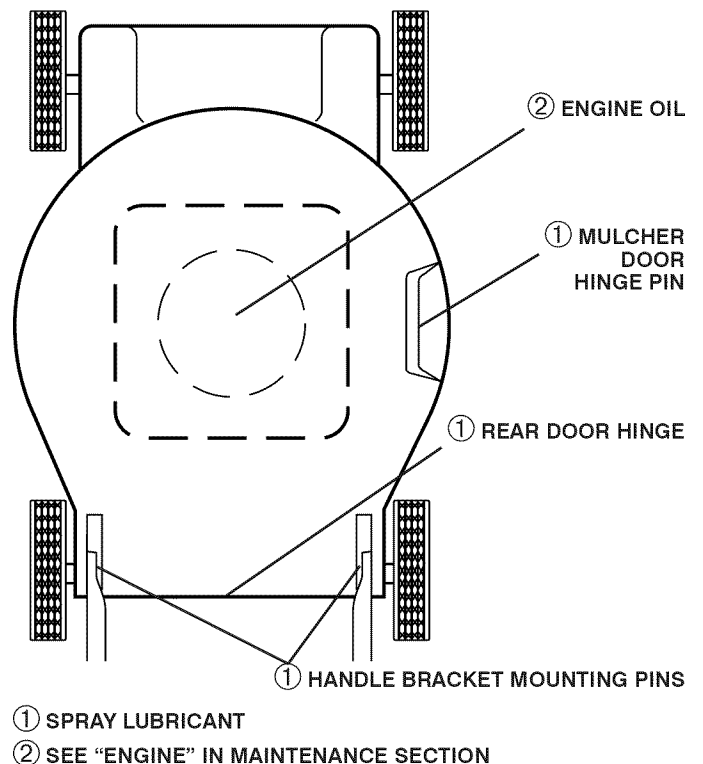

# MAINTENANCE

## LAWN MOWER

Always observe safety rules when performing maintenance.

### TIRES

- Keep tires free of gasoline, oil, or insect control chemicals which can harm rubber.
- Avoid stumps, stones, deep ruts, sharp objects and other hazards that may cause tire damage.

### DRIVE WHEELS

Check rear drive wheels each time you mow to be sure they move freely. The wheels not turning freely means trash, grass cuttings, etc., may be inside the drive wheel and dust cover area and must be cleaned out to free drive wheels.

If necessary to clean drive wheels, check both rear wheels.

### BLADE CARE

For best results, mower blade must be kept sharp. Replace a bent or damaged blade.



**CAUTION:** Use only a replacement blade approved by the manufacturer of your mower. Using a blade not approved by the manufacturer of your mower is hazardous, could damage your mower and void your warranty.

TO REMOVE BLADE (See Fig. 16)

1. Disconnect spark plug wire from spark plug and place wire where it cannot come in contact with plug.
2. Turn lawn mower on its side. Make sure air filter and carburetor are up.
3. Use a wood block between blade and mower housing to prevent blade from turning when removing blade bolts.

**NOTE:** Protect your hands with gloves and/or wrap blade with heavy cloth.

4. Remove blade bolts by turning counter-clockwise.

TO REPLACE BLADE (See Fig. 16)

1. Position the blade. Be sure trailing edge of blade (opposite sharp edge) is up toward the engine and install the blade bolts.
  2. Use block of wood between blade and lawn mower housing and tighten the blade bolts, turning clockwise.
- The recommended tightening torque is 35-40 ft. lbs.

**IMPORTANT:** BLADE BOLTS ARE HEAT TREATED. IF BOLTS NEED REPLACING, REPLACE ONLY WITH APPROVED BOLTS SHOWN IN THE REPAIR PARTS SECTION OF THIS MANUAL.

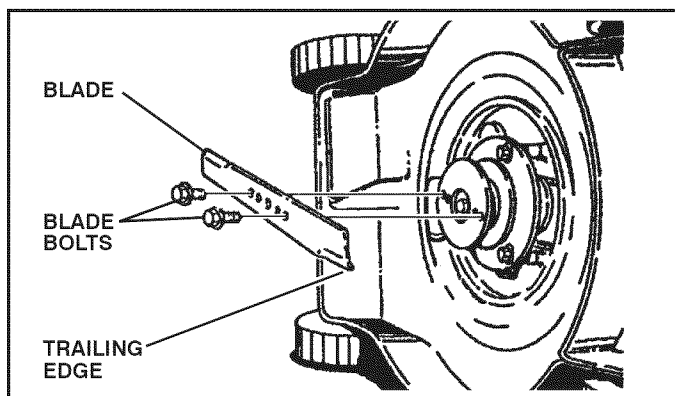

FIG. 16

TO SHARPEN BLADE

**NOTE:** We do not recommend sharpening blade - but if you do, be sure the blade is balanced. Care should be taken to keep the blade balanced. An unbalanced blade will cause eventual damage to lawn mower or engine.

- The blade can be sharpened with a file or on a grinding wheel. Do not attempt to sharpen while on the mower.
- To check blade balance, drive a nail into a beam or wall. Leave about one inch of the straight nail exposed. Place center hole of blade over the head of the nail. If blade is balanced, it should remain in a horizontal position. If either end of the blade moves downward, sharpen the heavy end until the blade is balanced.

### GRASS CATCHER

- The grass catcher may be hosed with water, but must be dry when used.
- Check your grass catcher often for damage or deterioration. Through normal use it will wear. If catcher needs replacing, replace only with approved replacement catcher shown in the Repair Parts section of this manual. Give the mower model number when ordering.

### GEAR CASE

- To keep your drive system working properly, the gear case and area around the drive should be kept clean and free of trash build-up. Clean under the drive cover twice a season.
- The gear case is filled with lubricant to the proper level at the factory. The only time the lubricant needs attention is if service has been performed on the gear case.
- If lubricant is required, use only Texaco Starplex Premium 1 Grease, Part No. 750369. Do not substitute.

## ENGINE LUBRICATION

Use only high quality detergent oil rated with API service classification SG-SL. Select the oil's SAE viscosity grade according to your expected operating temperature.

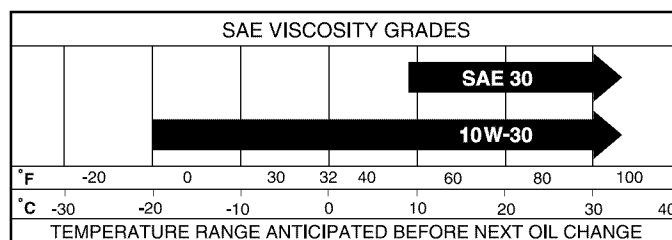

**NOTE:** Multi-viscosity oils (5W30, 10W30 etc.) improve starting in cold weather, and you should check your engine oil level frequently to avoid possible engine damage from running low on oil.

Change the oil after every 25 hours of operation or at least once a year if the lawn mower is not used for 25 hours in one year.

Check the crankcase oil level before starting the engine and after each five (5) hours of continuous use. Tighten oil plug securely each time you check the oil level.

# MAINTENANCE

## TO CHANGE ENGINE OIL (See Figs. 17 & 18)

**NOTE:** Before tipping lawn mower to drain oil, empty fuel tank by running engine until fuel tank is empty.

1. Disconnect spark plug wire from spark plug and place wire where it cannot come in contact with plug.
2. Remove oil fill cap/dipstick; lay aside on a clean surface.
3. Tip lawn mower on its side as shown and drain oil into a suitable container. Rock lawn mower back and forth to remove any oil trapped inside of engine.
4. Wipe off any spilled oil from lawn mower or side of engine.

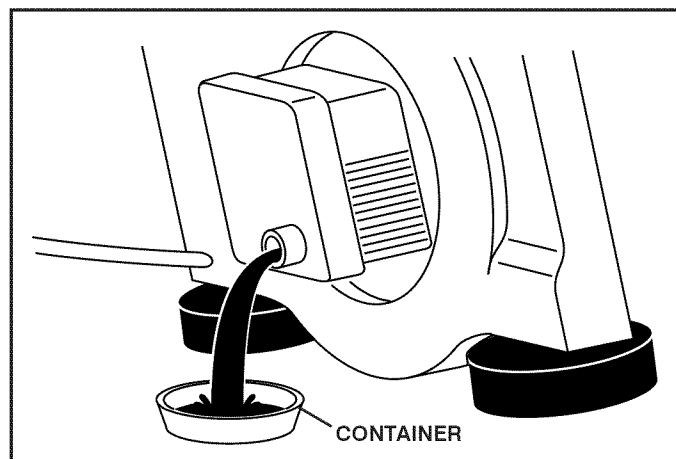

FIG. 17

5. Fill engine with oil. Slowly pour oil down the oil fill spout into the engine.
6. Wait one minute to allow oil to settle. Use gauge on oil fill cap/dipstick for checking level. Insert dipstick into the tube and rest the oil fill cap on the tube. **DO NOT** thread the cap into the tube when taking reading.
7. Continue adding small amounts of oil and rechecking the dipstick until it reads full. **DO NOT** overfill, or engine will smoke on startup.
8. Always be sure to retighten oil fill cap/dipstick before starting engine.
9. Reconnect spark plug wire to spark plug.

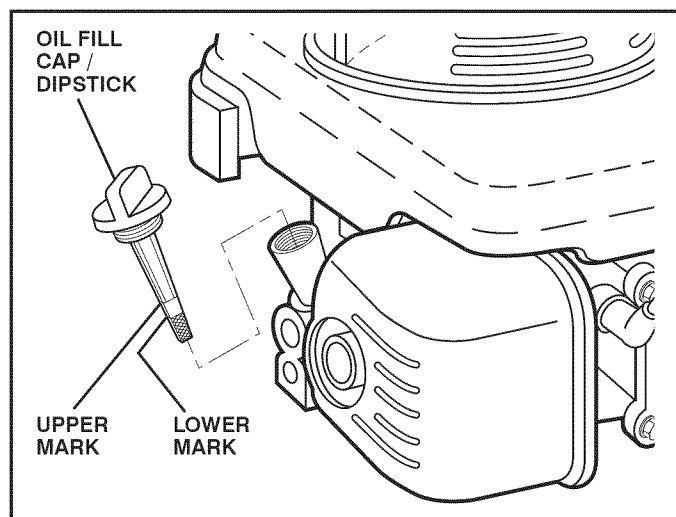

FIG. 18

## AIR FILTER

Your engine will not run properly and may be damaged by using a dirty air filter. Replace the air filter every 100 hours of operation or every season, whichever occurs first. Service air cleaner more often under dusty conditions. See the maintenance section of your engine manual.

## MUFFLER

Inspect and replace corroded muffler as it could create a fire hazard and/or damage.

## SPARK PLUG

Replace spark plug at the beginning of each mowing season or after every 100 hours of operation, whichever occurs first. Spark plug type and gap setting are shown in the "PRODUCT SPECIFICATIONS" section of this manual.

## CLEANING

**IMPORTANT:** FOR BEST PERFORMANCE, KEEP MOWER HOUSING FREE OF BUILT-UP GRASS AND TRASH. CLEAN THE UNDERSIDE OF YOUR MOWER AFTER EACH USE.



**CAUTION:** Disconnect spark plug wire from spark plug and place wire where it cannot come in contact with plug.

- Clean the underside of your lawn mower by scraping to remove build-up of grass and trash.
- Clean engine often to keep trash from accumulating. A clogged engine runs hotter and shortens engine life.
- Keep finished surfaces and wheels free of gasoline, oil, etc.
- We do not recommend using a garden hose to clean lawn mower unless the electrical system, muffler, air filter and carburetor are covered to keep water out. Water in engine can result in shortened engine life.

## CLEAN UNDER DRIVE COVER

Clean under drive cover at least twice a season. Scrape underside of cover with putty knife or similar tool to remove any build-up of trash or grass on underside of drive cover.

# SERVICE AND ADJUSTMENTS

**CAUTION:** To avoid serious injury, before performing any service or adjustments:



1. Release control bar and stop engine.
2. Make sure the blade and all moving parts have completely stopped.
3. Disconnect spark plug wire from spark plug and place where it cannot come in contact with plug.

## LAWN MOWER

### TO ADJUST CUTTING HEIGHT

See "TO ADJUST CUTTING HEIGHT" in the Operation section of this manual.

### REAR DEFLECTOR

The rear deflector, attached between the rear wheels of your mower, is provided to minimize the possibility that objects will be thrown out of the rear of the mower into the operator's mowing position. If the deflector becomes damaged, it should be replaced.

### TO REMOVE DRIVE BELT

If your mower does not operate properly due to suspected drive belt problems, take your mower to a qualified service center for repair and/or adjustment.

### TO ADJUST HANDLE (See Fig. 19)

The handle on your lawn mower has three (3) height positions - adjust to height that suits you.

- Squeeze the bottom ends of lower handle towards each other until the pin in handle can be inserted into one of the three height adjustment holes.

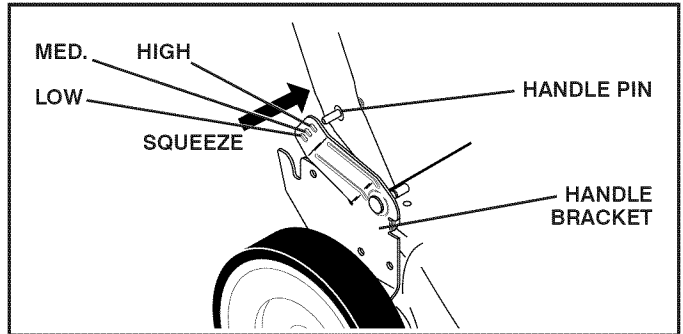

FIG. 19

## ENGINE

Maintenance, repair, or replacement of the emission control devices and systems, which are being done at the customer's expense, may be performed by any non-road engine repair establishment or individual. Warranty repairs must be performed by an authorized engine manufacturer's service outlet.

### ENGINE SPEED

Your engine speed has been factory set. Do not attempt to increase engine speed or it may result in personal injury. If you believe that the engine is running too fast or too slow, take your lawn mower to an authorized service center for repair and adjustment.

### CARBURETOR

Your carburetor is not adjustable. If your engine does not operate properly due to suspected carburetor problems, take your lawn mower to an authorized service center for repair and/or adjustment.

**IMPORTANT:** NEVER TAMPER WITH THE ENGINE GOVERNOR, WHICH IS FACTORY SET FOR PROPER ENGINE SPEED. OVERSPEEDING THE ENGINE ABOVE THE FACTORY HIGH SPEED SETTING CAN BE DANGEROUS. IF YOU THINK THE ENGINE-GOVERNED HIGH SPEED NEEDS ADJUSTING, CONTACT YOUR NEAREST AUTHORIZED SERVICE CENTER, WHICH HAS PROPER EQUIPMENT AND EXPERIENCE TO MAKE ANY NECESSARY ADJUSTMENTS.

# STORAGE

Immediately prepare your mower for storage at the end of the season or if the unit will not be used for 30 days or more.

## LAWN MOWER

When lawn mower is to be stored for a period of time, clean it thoroughly, remove all dirt, grease, leaves, etc. Store in a clean, dry area.

1. Clean entire lawn mower (See "CLEANING" in the Maintenance section of this manual).
2. Lubricate as shown in the Maintenance section of this manual.
3. Be sure that all nuts, bolts, screws, and pins are securely fastened. Inspect moving parts for damage, breakage and wear. Replace if necessary.
4. Touch up all rusted or chipped paint surfaces; sand lightly before painting.

### HANDLE (See Figs. 20 and 21)

You can fold your lawn mower handle for storage.

1. Loosen the two (2) handle knobs on sides of the upper handle and allow handle to fold down to the rear.
  2. Squeeze the bottom ends of lower handle toward each other until pins in handle clear the brackets and pivot entire handle assembly forward and allow it to rest on mower.
- When setting up your handle from the storage position, the lower handle will require manually locking into the mowing position.

**IMPORTANT:** WHEN FOLDING THE HANDLE FOR STORAGE OR TRANSPORTATION, BE SURE TO FOLD THE HANDLE AS SHOWN OR YOU MAY DAMAGE THE CONTROL CABLES.

# STORAGE

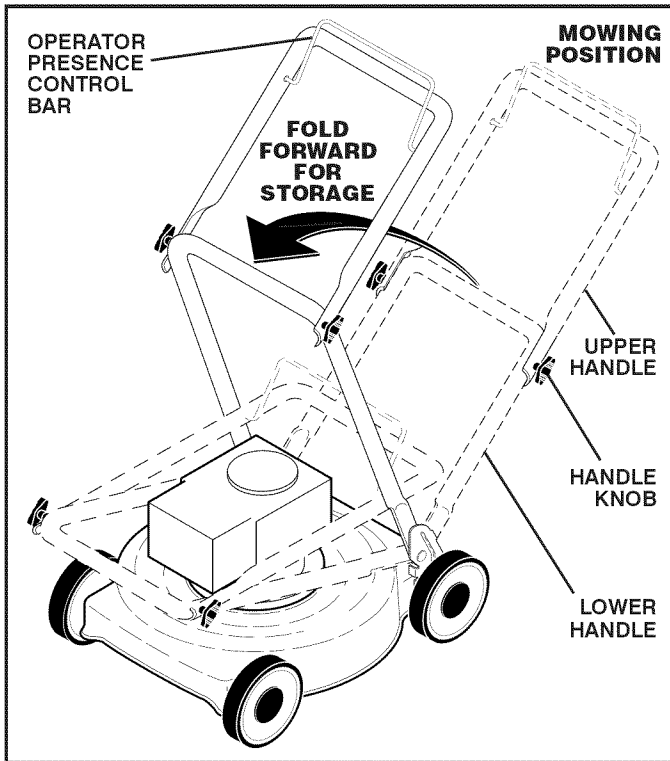

FIG. 20

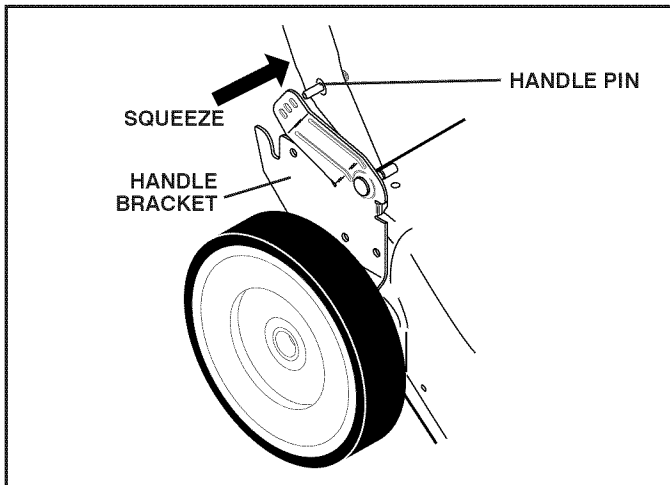

FIG. 21

## ENGINE FUEL SYSTEM

**IMPORTANT:** IT IS IMPORTANT TO PREVENT GUM DEPOSITS FROM FORMING IN ESSENTIAL FUEL SYSTEM PARTS SUCH AS CARBURETOR, FUEL FILTER, FUEL HOSE, OR TANK DURING STORAGE. ALCOHOL BLENDED FUELS (CALLED GASOHOL OR USING ETHANOL OR METHANOL) CAN ATTRACT MOISTURE WHICH LEADS TO SEPARATION AND FORMATION OF ACIDS DURING STORAGE. ACIDIC GAS CAN DAMAGE THE FUEL SYSTEM OF AN ENGINE WHILE IN STORAGE.

- Empty the fuel tank by starting the engine and letting it run until the fuel lines and carburetor are empty.
- Never use engine or carburetor cleaner products in the fuel tank or permanent damage may occur.
- Use fresh fuel next season.

**NOTE:** Fuel stabilizer is an acceptable alternative in minimizing the formation of fuel gum deposits during storage. Add stabilizer to gasoline in fuel tank or storage container. Always follow the mix ratio found on stabilizer container. Run engine at least 10 minutes after adding stabilizer to allow the stabilizer to reach the carburetor. Do not empty the gas tank and carburetor if using fuel stabilizer.

## ENGINE OIL

Drain oil (with engine warm) and replace with clean engine oil. (See "ENGINE" in the Maintenance section of this manual).

## CYLINDER

1. Remove spark plug.
2. Pour one ounce (29 ml) of oil through spark plug hole into cylinder.
3. Pull starter handle slowly a few times to distribute oil.
4. Replace with new spark plug.

## OTHER

- Do not store gasoline from one season to another.
- Replace your gasoline can if your can starts to rust. Rust and/or dirt in your gasoline will cause problems.
- If possible, store your unit indoors and cover it to give protection from dust and dirt.
- Cover your unit with a suitable protective cover that does not retain moisture. Do not use plastic. Plastic cannot breathe, which allows condensation to form and will cause your unit to rust.

**IMPORTANT:** NEVER COVER MOWER WHILE ENGINE AND EXHAUST ARE STILL WARM.



**CAUTION:** Never store the lawn mower with gasoline in the tank inside a building where fumes may reach an open flame or spark. Allow the engine to cool before storing in any enclosure.

# TROUBLESHOOTING

PROBLEM	CAUSE	CORRECTION
<b>Does not start</b>	<ol style="list-style-type: none"> <li>1. Dirty air filter.</li> <li>2. Out of fuel.</li> <li>3. Stale fuel.</li> <li>4. Water in fuel.</li> <li>5. Spark plug wire is disconnected.</li> <li>6. Bad spark plug.</li> <li>7. Loose blade or broken blade adapter.</li> <li>8. Control bar in released position.</li> <li>9. Control bar defective.</li> <li>10. Fuel valve lever (if so equipped) is in the OFF position.</li> <li>11. Weak battery (if equipped).</li> <li>12. Disconnected battery connector (if equipped).</li> <li>13. Engine control lever is in STOP position.</li> </ol>	<ol style="list-style-type: none"> <li>1. Clean/replace air filter.</li> <li>2. Fill fuel tank.</li> <li>3. Drain fuel tank and refill tank with fresh, clean gasoline.</li> <li>4. Drain fuel tank and refill tank with fresh, clean gasoline.</li> <li>5. Connect wire to plug.</li> <li>6. Replace spark plug.</li> <li>7. Tighten blade bolt or replace adapter.</li> <li>8. Depress control bar to handle.</li> <li>9. Replace control bar.</li> <li>10. Turn fuel valve lever to the ON position.</li> <li>11. Charge battery.</li> <li>12. Connect battery to engine.</li> <li>13. Place engine control lever in FAST position.</li> </ol>
<b>Loss of power</b>	<ol style="list-style-type: none"> <li>1. Rear of lawn mower housing or cutting blade dragging in heavy grass.</li> <li>2. Cutting too much grass.</li> <li>3. Dirty air filter.</li> <li>4. Buildup of grass, leaves, trash under mower.</li> <li>5. Too much oil in engine.</li> <li>6. Walking speed too fast.</li> </ol>	<ol style="list-style-type: none"> <li>1. Raise cutting height.</li> <li>2. Raise cutting height.</li> <li>3. Clean/replace air filter.</li> <li>4. Clean underside of mower housing.</li> <li>5. Check oil level.</li> <li>6. Cut at slower walking speed.</li> </ol>
<b>Poor cut – uneven</b>	<ol style="list-style-type: none"> <li>1. Worn, bent or loose blade.</li> <li>2. Wheel heights uneven.</li> <li>3. Buildup of grass, leaves, trash under mower.</li> </ol>	<ol style="list-style-type: none"> <li>1. Replace blade. Tighten blade bolt.</li> <li>2. Set all wheels at same height.</li> <li>3. Clean underside of mower housing.</li> </ol>
<b>Excessive vibration</b>	<ol style="list-style-type: none"> <li>1. Worn, bent or loose blade.</li> <li>2. Bent engine crankshaft.</li> </ol>	<ol style="list-style-type: none"> <li>1. Replace blade. Tighten blade bolt.</li> <li>2. Contact a qualified service center.</li> </ol>
<b>Starter rope hard to pull</b>	<ol style="list-style-type: none"> <li>1. Engine flywheel brake is on when control bar is released.</li> <li>2. Bent engine crankshaft.</li> <li>3. Blade adapter broken.</li> <li>4. Blade dragging in grass.</li> <li>5. Defective blade/brake clutch.</li> </ol>	<ol style="list-style-type: none"> <li>1. Depress control bar to upper handle before pulling starter rope.</li> <li>2. Contact a qualified service center.</li> <li>3. Replace blade adapter.</li> <li>4. Move mower to cut grass / hard surface.</li> <li>5. Replace blade/brake clutch.</li> </ol>
<b>Grass catcher is not filling (if so equipped)</b>	<ol style="list-style-type: none"> <li>1. Cutting height too low.</li> <li>2. Lift on blade worn off.</li> <li>3. Catcher not venting air.</li> </ol>	<ol style="list-style-type: none"> <li>1. Raise cutting height.</li> <li>2. Replace blade.</li> <li>3. Clean grass catcher.</li> </ol>
<b>Hard to push</b>	<ol style="list-style-type: none"> <li>1. Grass is too high or wheel height is too low.</li> <li>2. Rear of lawn mower housing or cutting blade dragging in heavy grass.</li> <li>3. Grass catcher too full.</li> <li>4. Handle height position is not right for you.</li> </ol>	<ol style="list-style-type: none"> <li>1. Raise cutting height.</li> <li>2. Raise cutting height.</li> <li>3. Empty grass catcher.</li> <li>4. Adjust handle height to suit.</li> </ol>
<b>Blade / brake does not engage</b>	<ol style="list-style-type: none"> <li>1. Defective blade / brake control.</li> </ol>	<ol style="list-style-type: none"> <li>1. Replace blade / brake control.</li> </ol>
<b>Engine dies when starting blade</b>	<ol style="list-style-type: none"> <li>1. Cold engine.</li> <li>2. Mower is in uncut grass.</li> </ol>	<ol style="list-style-type: none"> <li>1. Allow engine to warm up for one minute.</li> <li>2. Move mower to cleared area.</li> </ol>
<b>Loss of drive or slowing of drive speed (if self-propelled)</b>	<ol style="list-style-type: none"> <li>1. Belt wear.</li> <li>2. Belt off of pulley.</li> <li>3. Drive cable worn or broken.</li> <li>4. "Loose" drive control system.</li> </ol>	<ol style="list-style-type: none"> <li>1. Check/replace drive belt.</li> <li>2. Check/reinstall drive belt.</li> <li>3. Replace drive cable.</li> <li>4. Adjust drive control.</li> </ol>



---

# SERVICE NOTES

---

# Husqvarna WARRANTY STATEMENT

## **SECTION 1: LIMITED WARRANTY**

Husqvarna Forest & Garden Company ("Husqvarna") warrants Husqvarna product to the original purchaser to be free from defects in material and workmanship from the date of purchase for the "Warranty Period" of the product as set forth below:

**Lifetime Warranty (Parts and Labor):** All tiller tines and trimmer shafts against breakage. Proof of purchase required.

**Lifetime Warranty ("PARTS ONLY" after initial warranty expiration):** Ignition coils and modules on handheld product.

Proof of purchase required.

### **WARRANTY SCHEDULE FOR TURF CARE Equipment - Zero Turn Riders**

(New warranty applies to units sold after August 1, 2005. Also applies to units factory-equipped with R.O.P.S.)

**EZ Zero Turn Riders:** 3 year consumer warranty or 600 hours of use (when used solely at the owner's residence.)

**EZ Zero Turn Riders:** 1 year commercial warranty or 600 hours of use.

**IZ, LZ & BZ Zero Turn Riders:** 5 year consumer warranty or 1,500 hours of use (when used solely at the owner's residence.)

**IZ, LZ & BZ Zero Turn Riders:** 5 year commercial warranty or 1,500 hours of use.

**3 Year or 1,500 Hour Commercial Use Warranty:** spindles on zero turn riders, hydraulic pumps and wheel motors.

Warranty Schedule for Turf Care Walk Behind Units - W, WG & WH Zero Turn Riders - 3 year consumer and commercial warranty. New warranty applies to units sold after August 1, 2005. Also applies to units factory-equipped with R.O.P.S.

**2 Year COMMERCIAL and CONSUMER Warranty:** all Husqvarna ground-engaging commercial equipment.

### **WARRANTY SCHEDULE FOR CONSUMER TURF CARE EQUIPMENT:**

**2 Year Consumer Warranty:** Automatic mower, all Residential Zero Turn Riders, all lawn, yard and garden tractors, all noncommercial walk behind mowers, tillers, chain saws, trimmers, brushcutters, clearing saws, snow blowers, handheld blowers, backpack blowers, hedge trimmers, electrical products and power-assist collection systems for noncommercial, nonprofessional, noninstitutional or nonincome producing use, except as herein stated. All consumer product use must have been limited to the owner's residence.

### **WARRANTY SCHEDULE FOR CONSUMER FOREST & GARDEN EQUIPMENT:**

**2 Year Consumer Warranty:** all consumer chain saws, trimmers, brushcutters, clearing saws, handheld blowers, backpack blowers, hedge trimmers, and electrical products for noncommercial, nonprofessional, noninstitutional or nonincome producing use, except as herein stated. All consumer product use must have been limited to the owner's residence.

**2 Year or 2,000 Hour Powertrain & 1 Year or 1,000 Hour Body Warranty:** Husqvarna Utility Vehicles.

**1 Year Warranty:** Power cutters, stump grinder, pole pruners and pole saws for non-commercial, non-professional, noninstitutional, non-municipality or non-income producing use. All 300 series trimmers, brushcutters, clearing saws, hovering trimmers, stick edgers, backpack blowers, hand held blowers, hedge trimmers, power-assist collection systems for commercial, institutional, professional or income producing purposes or use.

**1 Year Conditional Component Warranty:** Chain saw crankshafts for commercial/professional use (parts and labor). Saw must be operated with Husqvarna XP 2 cycle oil.

**90 Day Commercial Warranty:** Automatic mower, chain saws, 100 series trimmers, power cutters, stump grinders, pole saws, pole pruners, snow throwers, model series 580 & 600 walk-behind mowers, or any Husqvarna product used for commercial, institutional, professional, municipality or income producing purposes or use except as otherwise provided herein.

**Batteries:** 1 year prorated limited warranty with 100% replacement during the first 6 months.

**Rental Warranty:** 90 days on all applicable professional equipment reference warranty time period charts located in the back of the Retailer Warranty Policy & Procedure Manual.

**Husqvarna Safety Apparel** carries a 90-day warranty from the date of the customer's original purchase for defects in material and workmanship. Normal wear, tear or abuse is not covered under warranty. Product must be returned to Charlotte with a warranty claim form. All care and maintenance instructions must be followed as stated by the manufacturer on the care label. The fit of the protective apparel/boot is not covered under warranty.

**30 Day Warranty:** Replacement parts, accessories including bars and chains, tools and display items. Emission control system components necessary to comply with CARB-TIER II and EPA regulations, except for those components which are part of engine systems manufactured by third part engine manufacturers for which the purchaser has received a separate warranty with product at time of purchase.

## **SECTION 2: HUSQVARNA'S OBLIGATIONS UNDER THE WARRANTY**

Husqvarna will repair or replace defective components without charge for parts or labor if a component fails because of a defect in material or workmanship during the warranty period.

## **SECTION 3: ITEMS NOT COVERED BY THIS WARRANTY**

The following items are not covered by this warranty:

(1) Normal customer maintenance items which become worn through normal regular use, including, but not limited to, belts, blades, blade adapters, bulbs, clutches, clutch drums, filters, guide bars, lubricants, rewind springs, saw chain, spark plugs,

starter ropes and tines;

(2) Natural discoloration of material due to ultraviolet light;

(3) Engine and drive systems not manufactured by Husqvarna; these items are covered by the respective manufacturer's warranty as provided in writing with the product information supplied at the time of purchase; all claims must be sent to the appropriate manufacturer;

(4) Lawn and garden attachments are covered by a third party which gives a warranty, all claims for warranty should be sent to the manufacturer,

(5) Commercial or consumer mowing decks with sand abrasion damage.

(6) Emission Control System components necessary to comply with CARB-TIER II and EPA regulations which are manufactured by third party engine manufacturer.

## **SECTION 4: EXCEPTIONS AND LIMITATIONS**

This warranty shall be inapplicable to defects resulting from the following:

(1) Accident, abuse, misuse, negligence and neglect, including stale fuel, dirt, abrasives, moisture, rust, corrosion, or any adverse reaction due to incorrect storage or use habits;

(2) Failure to operate or maintain the unit in accordance with the Owner's/Operator's manual or instruction sheet furnished by Husqvarna;

(3) Alterations or modifications that change the intended use of the product or affects the product's performance, operation, safety, or durability, or causes the product to fail to comply with any applicable laws; or;

(4) Additional damage to parts or components due to continued use occurring after any of the above.

REPAIR OR REPLACEMENT AS PROVIDED UNDER THIS WARRANTY IS THE EXCLUSIVE REMEDY OF THE PURCHASER. HUSQVARNA SHALL NOT BE LIABLE FOR ANY INCIDENTAL OR CONSEQUENTIAL DAMAGES FOR BREACH OF ANY EXPRESS OR IMPLIED WARRANTY ON THESE PRODUCTS EXCEPT TO THE EXTENT PROHIBITED BY APPLICABLE LAW. ANY IMPLIED WARRANTY OF MERCHANTABILITY OR FITNESS FOR A PARTICULAR PURPOSE ON THESE PRODUCTS IS LIMITED IN DURATION TO THE WARRANTY PERIOD AS DEFINED IN THE LIMITED WARRANTY STATEMENT. HUSQVARNA RESERVES THE RIGHT TO CHANGE OR IMPROVE THE DESIGN OF THE PRODUCT WITHOUT NOTICE, AND DOES NOT ASSUME OBLIGATION TO UPDATE PREVIOUSLY MANUFACTURED PRODUCTS.

Some states do not allow the exclusion of incidental or consequential damages, or limitations on how long an implied warranty lasts, so the above limitations or exclusions may not apply to you. This warranty gives you specific legal rights, and you may also have other rights which vary from state to state.

## **SECTION 5: CUSTOMER RESPONSIBILITIES**

The product must exhibit reasonable care, maintenance, operation, storage and general upkeep as written in the maintenance section of the Owner's/Operator's manual. Should an operational problem or failure occur, the product should not be used, but delivered as is to an authorized Husqvarna retailer for evaluation. Proof of purchase, as explained in section 6, rests solely with the customer.

## **SECTION 6: PROCEDURE TO OBTAIN WARRANTY CONSIDERATION**

It is the Owner's and Retailer's responsibility to make certain that the Warranty Registration Card is properly filled out and mailed to Husqvarna Forest & Garden Company. This card should be mailed within ten (10) days from the date of purchase in order to confirm the warranty and to facilitate post-sale service.

Proof of purchase must be presented to the authorized Husqvarna retailer in order to obtain warranty service. This proof must include date purchased, model number, serial number, and complete name and address of the selling retailer.

To obtain the benefit of this warranty, the product believed to be defective must be delivered to an authorized Husqvarna retailer in a timely manner, no later than thirty (30) days from date of the operational problem or failure. The product must be delivered at the owner's expense. Downtime, pick-up and delivery charges are not covered by this warranty. An authorized Husqvarna retailer can be normally located through the "Yellow Pages" of the local telephone directory or by calling 1-800-HUSKY62 for a retailer in your area.

**HUSQVARNA**  
7349 Statesville Road  
Charlotte, NC 28269

Nov 2006