

# Installation Instructions

**NOTE:** Read the entire instruction manual before starting the installation.

## SAFETY CONSIDERATIONS

Improper installation, adjustment, alteration, service, maintenance, or use can cause explosion, fire, electrical shock, or other conditions which may cause death, personal injury, or property damage. Consult a qualified installer, service agency, or your distributor or branch for information or assistance. The qualified installer or agency must use factory-authorized kits or accessories when modifying this product. Refer to the individual instructions packaged with the kits or accessories when installing.

Follow all safety codes. Wear safety glasses, protective clothing, and work gloves. Have a fire extinguisher available. Read these instructions thoroughly and follow all warnings or cautions include in literature and attached to the unit. Consult local building codes, the current editions of the National Fuel Gas Code (NFGC) NFPA 54/ANSI Z223.1 and the National Electrical Code (NEC) NFPA 70.

In Canada, refer to the current editions of the National Standards of Canada CAN/CGA–B149.1 and .2 Natural Gas and Propane Installation Codes, and Canadian Electrical Code CSA C22.1

Recognize safety information. This is the safety-alert symbol . When you see this symbol on the unit and in instructions or manuals, be alert to the potential for personal injury.

Understand the signal words **DANGER**, **WARNING**, and **CAUTION**. These words are used with the safety-alert symbol. **DANGER** identifies the most serious hazards which **will** result in severe personal injury or death. **WARNING** signifies hazards which **could** result in personal injury or death. **CAUTION** is used to identify unsafe practices which **may** result in minor personal injury or product and property damage. **NOTE** is used to highlight suggestions which **will** result in enhanced installation, reliability, or operation.

## WARNING

### FIRE, EXPLOSION, ELECTRICAL SHOCK HAZARD

Failure to follow this warning could result in personal injury, death and/or property damage.

Before installing or servicing unit, always turn off main electrical and gas to unit and tag with appropriate lockout. There may be more than one disconnect switch.

## CAUTION

### CUT HAZARD

Failure to follow this caution may result in personal injury. Sheet metal parts may have sharp edges or burrs. Use care and wear appropriate protective clothing, safety glasses and gloves when handling parts and servicing furnaces.

## CAUTION

### UNIT DAMAGE HAZARD

Failure to follow this caution may result in improper and dangerous operation. Label all wires prior to disconnection when servicing controls.

Table 1 – Kit Applicability

KIT PART NUMBER	UNIT	
	352MAV 352AAV 353BAV PG9MXA	58MEC 58MTA 58MTB
326058-755	036060	060-12
326058-756	036080 048080	080-12 080-16
326058-757	048100 060100	100-16 100-20
326058-758	060120	120-20

## INTRODUCTION

This instruction covers installation of the permanent split capacitor (PSC) two-speed motor inducer assembly kit. See Table 1 for kit applicability.

## DESCRIPTION AND USAGE

Use this PSC two-speed inducer assembly kit to replace a failed inducer motor assembly. This kit contains the following items:

- Inducer assembly 1
- Installation Instructions 1

**NOTE:** Inducer assembly consists of motor and fan, capacitor, wheel, motor mount, inducer cover, inducer housing, vent cap, and vent clamp.

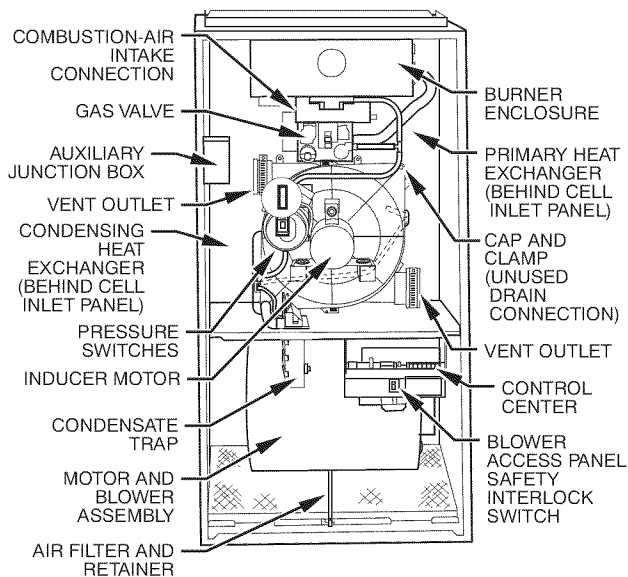

A01026

**Fig. 1 - Inducer Motor Assembly in Upflow Furnace Orientation**

## INSTALLATION

### Step 1 — Remove Old Motor Assembly

1. Turn off gas and electrical supplies to unit.
2. Remove main furnace door.
3. Remove drain tube from inducer motor mounting cover plate.
4. Remove pressure switch tubes. (See Fig. 1.)
  - a. Remove tube attached to pressure switch from collector box.
  - b. Remove tube attached to pressure switch from burner enclosure and gas valve.
5. Remove screws securing pressure switches to inducer housing.
6. Disconnect motor lead connector at quick-connect.
7. Disconnect vent pipe from inducer housing by loosening coupling clamp on inducer outlet. If coupling has 2 clamps, loosen clamp on vent pipe side. Move pipe out of furnace casing.
8. Using backup wrench, disconnect gas supply pipe from gas valve.
9. Remove wires from gas valve. Note location for reassembly.
10. Remove burner enclosure cover.
11. Remove screws securing manifold to burner enclosure.
12. Remove manifold, orifices, and gas valve as 1 assembly.
13. Remove 4 bolts attaching inducer housing assembly to heat exchanger cell panel.

### Step 2 — Install New Motor Assembly

1. Inspect seal on collector box. (See Fig. 2.)

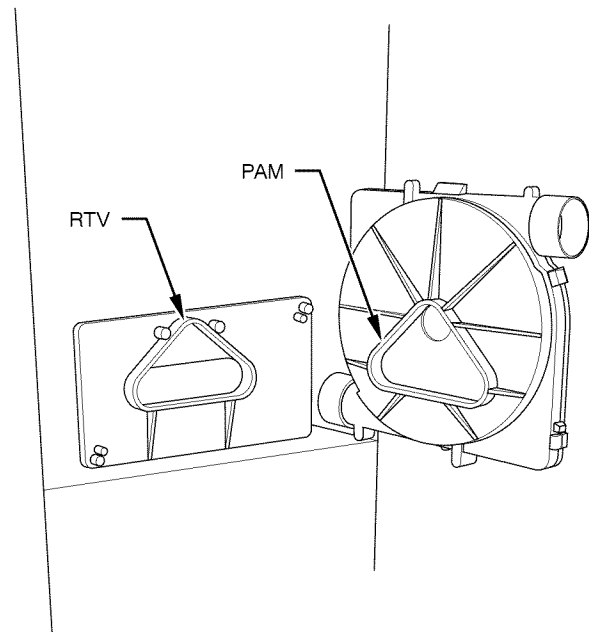

A093081

**Fig. 2 - Inducer Housing to Collector Box Gasket**

**NOTE:** If a collector box is damaged in any way, it must be repaired. To repair, apply sealant releasing agent such as PAM cooking spray or equivalent (must not contain corn nor canola oil, halogenated hydrocarbons, nor aromatic content to prevent inadequate sealing) to inducer housing. Apply a small bead of G.E. RTV 162, G.E. 6702, or Dow-Corning RTV 738 sealant to groove in collector box. G.E. 162 (P771-9003) is available through RCD in 3-oz. tubes.

2. Remove 4 bolts and spacers from old inducer housing assembly.
3. Install spacers in new inducer housing.
4. Insert bolts through inducer housing. **NOTE:** Inserting bolts at this time will add to the ease of their installation later.
5. Install new inducer housing assembly to heat exchanger cell panel by aligning guide pins in collector box. **NOTE:** Do not pinch collector box pressure tube when assembling inducer housing to collector box.
6. Tighten 4 bolts securing inducer housing assembly to heat exchanger cell panel.
7. Secure pressure switches to inducer motor mounting cover plate using mounting screw from old assembly.
8. Reconnect pressure switch tubes. See tubing label on furnace for proper connections.
  - a. Connect tube from burner enclosure and gas valve to pressure switch.
  - b. Connect tube from collector box to pressure switch.
9. Reconnect motor leads to quick-connect.
10. Reconnect drain tube to inducer motor mounting cover plate.
11. Remove cap and clamp from unused drain connection on old inducer motor mounting cover plate and install on new inducer motor mounting cover plate.

12. Connect vent pipe by inserting through elastomeric (rubber) coupling and then fully into inducer housing outlet. Tighten coupling clamp screw(s) to 15 in.-lb of torque.

## **WARNING**

### **FIRE AND EXPLOSION HAZARD**

Failure to follow this warning could result in personal injury, death, and or property damage.

After completing installation, vent pipe must be installed and fully seated against inducer housing internal stop. Coupling clamp screw(s) must be tightened to 15 in.-lb of torque to prevent disassembly of vent from furnace, and to prevent vent gas and condensate leakage.

13. Reinstall manifold assembly with gas valve to burner box. Replace mounting screws.
14. Replace burner box cover.
15. Using backup wrench, reconnect gas supply pipe to gas valve to prevent rotation and improper orientation.

**NOTE:** Use propane gas resistant pipe dope to prevent gas leaks. DO NOT use Teflon tape.

## **WARNING**

### **FIRE AND EXPLOSION HAZARD**

Failure to follow this warning could result in personal injury, death and/or property damage.

Gas valve switch or knob **MUST** be facing forward or tilted upward.

16. Reconnect wires to gas valve. Refer to furnace wiring diagram for proper wire location.
17. Turn on gas and electrical supplies to unit.
18. Check for gas leaks.

## **WARNING**

### **FIRE AND EXPLOSION HAZARD**

Failure to follow this warning could result in personal injury, death, and/or property damage.

Never check for gas leaks with an open flame. Use a commercially available soap solution made specifically for the detection of leaks to check all connections.

19. Check furnace operation through two complete cycles.
20. Reinstall main furnace door.

326058