

WAGNER®

PROCOAT™

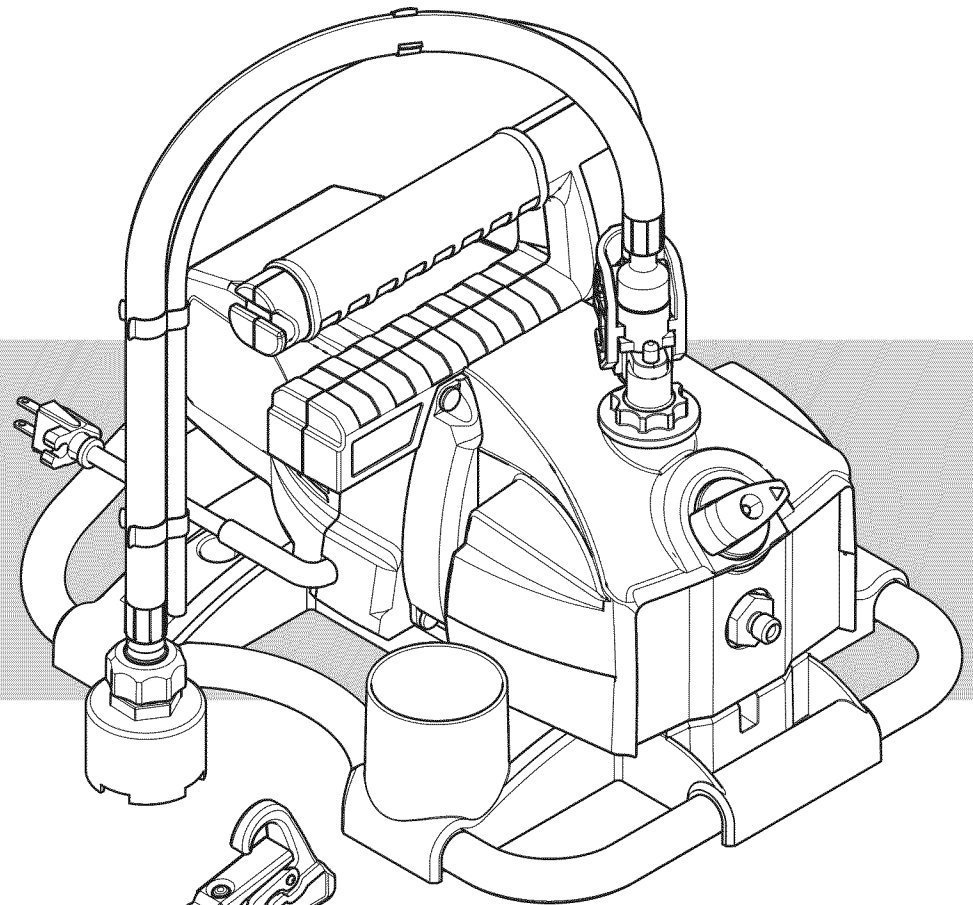

Owner's Manual

Read this manual for complete instructions

Français (page 25) / Español (página 49)

Contents

- | | |
|--------------------------------|--------------------------------------|
| 2 Important Safety Information | 14 Clean the Inlet Filter |
| 4 What's in the Box? | 15 Short Term Storage |
| 5 Assembly | 16 Cleanup - latex materials |
| 6 Proper Use and Functions | 18 Cleanup - oil-based materials |
| 7 Pressure Relief Procedure | 19 Cleaning the Spray Gun Components |
| 8 Load Material | 20 Long-Term Storage |
| 9 Getting Material to Flow | 21 Replacing the Outlet/Inlet Valves |
| 10 Practice Spraying | 22 Troubleshooting |
| 12 Clear the Spray Tip | 72 Parts List |
| 13 Clean the Spray Gun Filter | 76 Warranty |

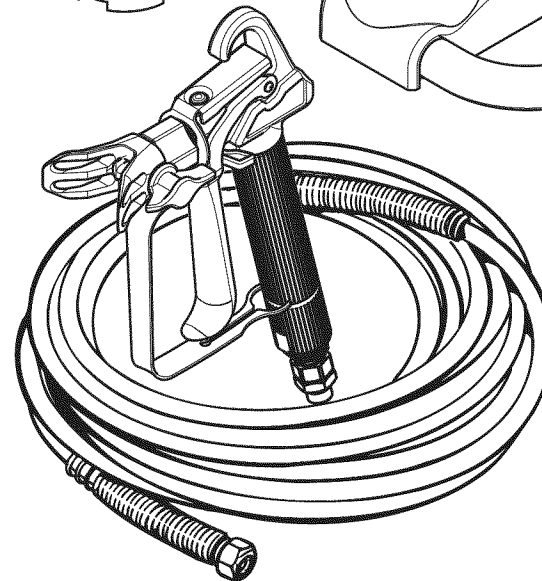

Important Safety Information

 **Read all safety information before operating the equipment. Save these instructions**

To reduce the risks of fire or explosion, electrical shock and the injury to persons, read and understand all instructions included in this manual. Be familiar with the controls and proper usage of the equipment.



Indicates a hazardous situation which, if not avoided, could result in death or serious injury.

HAZARD: INJECTION INJURY

A high pressure paint stream produced by this equipment can pierce the skin and underlying tissues, leading to serious injury and possible amputation. See a physician immediately.



DO NOT TREAT AN INJECTION INJURY AS A SIMPLE CUT! Injection can lead to amputation. See a physician immediately.

The maximum operating range of the gun is 2800 PSI/193 BAR fluid pressure.

PREVENTION:

- NEVER aim the gun at any part of the body.
- Do not aim the gun at, or spray any person or animal.
- NEVER allow any part of the body to touch the fluid stream. DO NOT allow body to touch a leak in the fluid hose.
- NEVER put your hand in front of the gun. Gloves will not provide protection against an injection injury.
- ALWAYS lock the gun trigger, shut the pump off, and release all pressure before servicing, cleaning the tip or guard, changing tip, or leaving unattended. Pressure will not be released by turning off the motor. The PRIME/SPRAY knob must be turned to PRIME to relieve the pressure. Refer to the Pressure Relief Procedure (page 7) described in the pump manual.
- ALWAYS keep the tip guard in place while spraying. The tip guard provides some protection but is mainly a warning device.

- ALWAYS remove the spray tip before flushing or cleaning the system.
- Paint hose can develop leaks from wear, kinking and abuse. A leak can inject material into the skin. Inspect the hose before each use. Do not use hose to lift or pull equipment.
- NEVER use a spray gun without a working trigger lock and trigger guard in place.
- All accessories must be rated at or above 2800 PSI/193 BAR. This includes spray tips, guns, extensions, and hose.

NOTE TO PHYSICIAN:

Injection into the skin is a traumatic injury. It is important to treat the injury as soon as possible. DO NOT delay treatment to research toxicity. Toxicity is a concern with some coatings injected directly into the blood stream. Consultation with a plastic surgeon or reconstructive hand surgeon may be advisable.

HAZARD: HAZARDOUS VAPORS

Paints, solvents, insecticides, and other materials can be harmful if inhaled or come in contact with the body. Vapors can cause severe nausea, fainting, or poisoning.



PREVENTION:

- Use a respirator or mask if vapors can be inhaled. Read all instructions supplied with the mask to be sure it will provide the necessary protection.
- Wear protective eye wear.
- Wear protective clothing as required by coating manufacturer.



HAZARD: EXPLOSION OR FIRE

Solvent and paint fumes can explode or ignite. Property damage and/or severe injury can occur.



PREVENTION:

- Provide extensive exhaust and fresh air introduction to keep the air within the spray area free from accumulation of flammable vapors. Solvent and paint fumes can explode or ignite.
- Do not spray in a confined area.
- Avoid all ignition sources such as static electric sparks, open flames, pilot lights, electrical appliances, and hot objects. Connecting or disconnecting power cords or working light switches can make sparks. Paint or solvent flowing through the equipment is able to result in static electricity.



- Do not smoke in spray area.
- Fire extinguisher must be present and in good working order.
- Place paint pump in a well-ventilated area away from the spray object. Flammable vapors are often heavier than air. Floor area must be extremely well ventilated.
- The equipment and objects in and around the spray area must be properly grounded to prevent static sparks.
- Keep area clean and free of paint or solvent containers, rags and other flammable materials.
- Use only conductive or grounded high pressure fluid hose. Gun must be grounded through hose connections.
- Power cord must be connected to a grounded circuit.
- Always flush unit into a separate metal container, at low pump pressure, with spray tip removed. Hold gun firmly against side of container to ground container and prevent static sparks.
- Follow the material and solvent manufacturer's warnings and instructions. Know the contents of the paints and solvents being sprayed. Read all Material Safety Data Sheets (MSDS) and container labels provided with the paints and solvents. Follow the paint and solvent manufacturer's safety instructions.
- This product may be used only with water-based materials or materials with a minimum flash point of 70°F (21°C) for spraying or cleaning. Do not spray or clean with materials having a flash point less than 70°F (21°C), such as solvent based lacquers, enamels, and/or stain blockers. Flash point is the temperature at which a fluid can produce enough vapors to ignite.
- Plastic can cause static sparks. Never hang plastic to enclose a spray area. Do not use plastic drop cloths when spraying flammable materials.
- Use lowest possible pressure to flush equipment.
- Do not spray onto pump assembly.

HAZARD: EXPLOSION HAZARD DUE TO INCOMPATIBLE MATERIALS

Will cause property damage or severe injury.



PREVENTION:

- Do not use materials containing bleach or chlorine.
- Do not use halogenated hydrocarbon solvents such as bleach, mildewcide, methylene chloride and 1,1,1 - trichloroethane. They are not compatible with aluminum.
- Contact your coating supplier about the compatibility of material with aluminum.

HAZARD: GENERAL

Can cause severe injury or property damage.

PREVENTION:

- Read all instructions and safety precautions before operating equipment.
- Follow all appropriate local, state, and national codes governing ventilation, fire prevention, and operation.
- The United States Government Safety Standards have been adopted under the Occupational Safety and Health Act (OSHA). These standards, particularly part 1910 of the General Standards and part 1926 of the Construction Standards should be consulted.
- Use only manufacturer authorized parts. User assumes all risks and liabilities when using parts that do not meet the minimum specifications and safety requirements of the pump manufacturer.
- Before each use, check all hoses for cuts, leaks, abrasion or bulging of cover. Check for damage or movement of couplings. Immediately replace the hose if any of these conditions exist. Never repair a paint hose. Replace it with another grounded high-pressure hose.
- All hoses and fittings must be secured before operating spray pump. Unsecured parts can eject at great force or leak a high pressure fluid stream causing severe injury.
- All hoses, swivels, guns, and accessories must be pressure rated at or above 2800 PSI/193 BAR.
- Do not spray outdoors on windy days.
- Wear clothing to keep paint off skin and hair.
- Do not operate or spray near children. Keep children away from the equipment at all times.
- Do not overreach or stand on an unstable support. Keep effective footing and balance at all times.
- Stay alert and watch what you are doing.
- Do not operate the unit when fatigued or under the influence of drugs or alcohol.

Important Electrical Information

IMPORTANT: Use only a 3-wire extension cord that has a 3-blade grounding plug and a 3-slot receptacle that will accept the plug on the product. Make sure your extension cord is in good condition. When using an extension cord, be sure to use one heavy enough to carry the current your product will draw. An undersized cord will cause a drop in line voltage resulting in loss of power and overheating. A 14 or 12 gauge cord is recommended (see chart). If an extension cord is to be used outdoors, it must be marked with the suffix W-A after the cord type designation. For example, a designation of SJTW-A would indicate that the cord would be appropriate for outdoor use.

Wagner Spray Tech accessory extension cords recommended:

P/N 0090241 - 20 foot extension cord.

P/N 0090242 - 35 foot extension cord.

Cord gauge	Maximum cord length
12	150 feet
14	100 feet

Do not use more than 50 feet of spray hose. If you need to spray further than 50 feet from your power source, use more extension cord, not more spray hose.

Grounding Instructions

This product must be grounded. In the event of an electrical short circuit, grounding reduces the risk of electric shock by providing an escape wire for the electric current. This product is equipped with a cord having a grounding wire with an appropriate grounding plug. The plug must be plugged into an outlet that is properly installed and grounded in accordance with all local codes and ordinances.

WARNING - Improper installation of the grounding plug can result in a risk of electric shock.



If repair or replacement of the cord or plug is necessary, do not connect the green grounding wire to either a flat blade terminal. The wire with insulation having a green outer surface with or without yellow stripes is the grounding wire and must be connected to the grounding pin.

Check with a qualified electrician or serviceman if the grounding instructions are not completely understood, or if you are in doubt as to whether the product is properly grounded. Do not modify the plug provided. If the plug will not fit the outlet, have the proper outlet installed by a qualified electrician.

This product is for use on a nominal 120 volt circuit and has a grounding plug that looks like the plug illustrated below. Make sure that the product is connected to an outlet having the same configuration as the plug. No adapter should be used with this product.

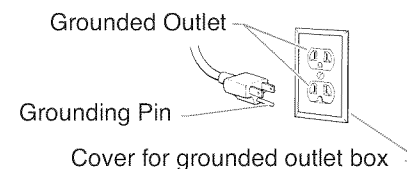

If you experience problems with your sprayer at any time during assembly, operation, or cleanup, please refer to the Troubleshooting section of this manual (page 22), or call customer service at:

1-800-328-8251

What's in the box?

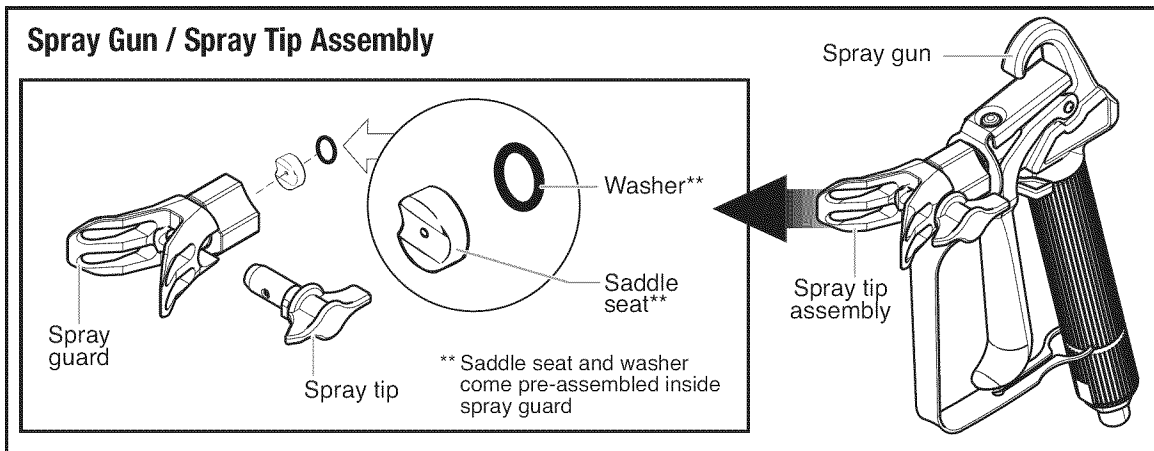
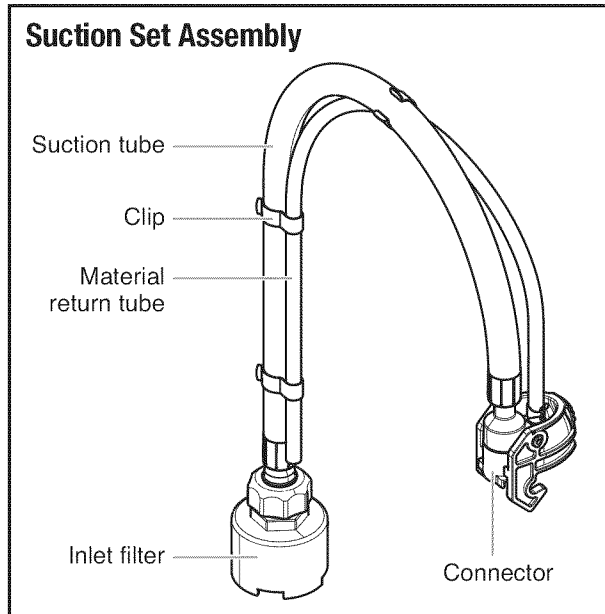
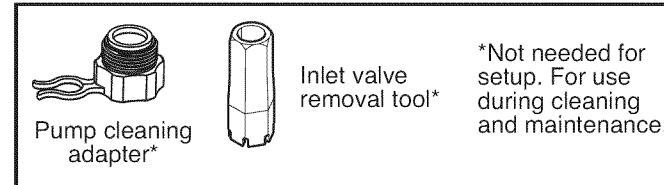
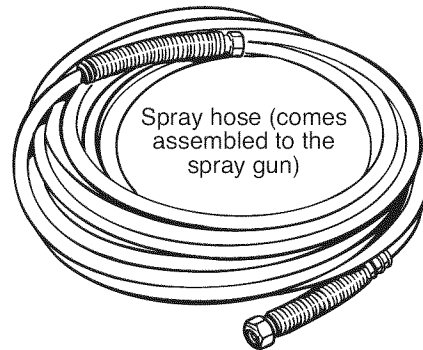
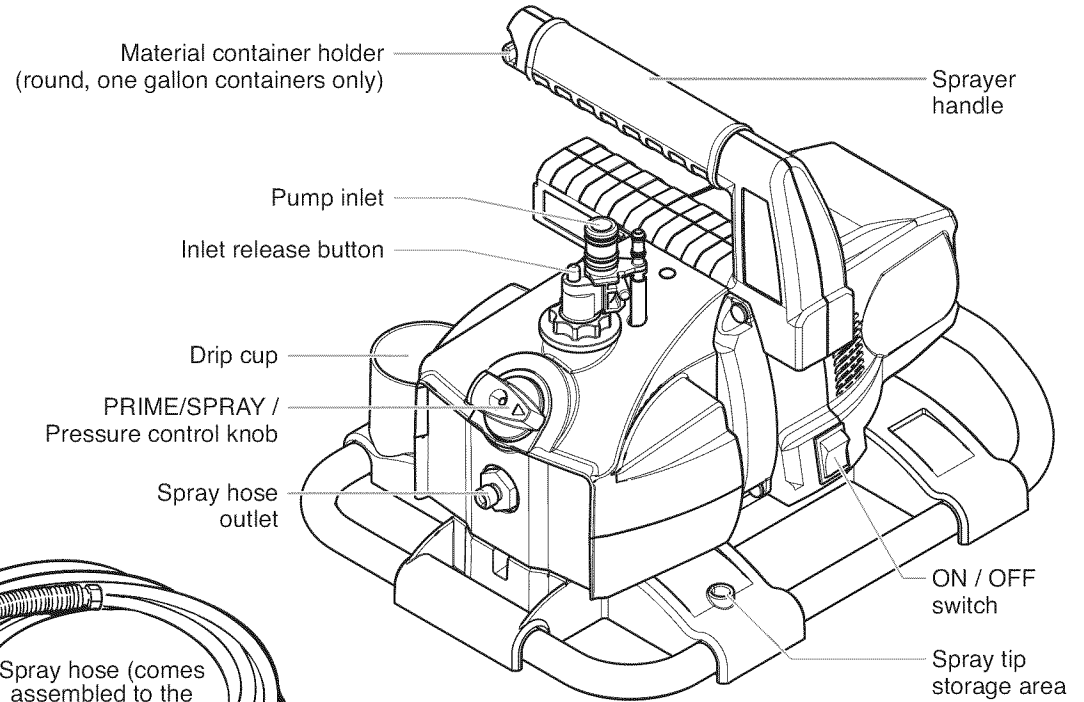

Questions?

Call Wagner Technical Service at:
1-800-328-8251

Register your product online at:
www.wagnerspraytech.com

1. Assembly

You will need:

- Adjustable wrench

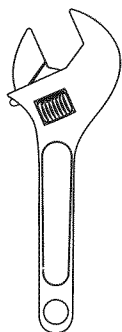

IMPORTANT: Do not plug in the power cord until assembly is complete.

IMPORTANT: Do not carry the sprayer by the suction set. Use the sprayer handle when moving the sprayer.

IMPORTANT: If you plan to use spray material contained in anything except a round, one gallon container, you will not be able to hook it to the container holder.

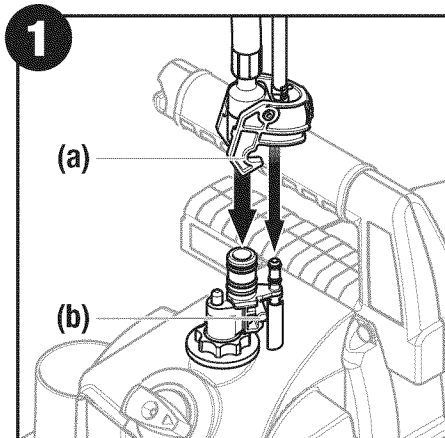

1. Attach the suction set to the pump as shown. Make sure the connector notches (a) snap over the pins (b) on the pump inlet.

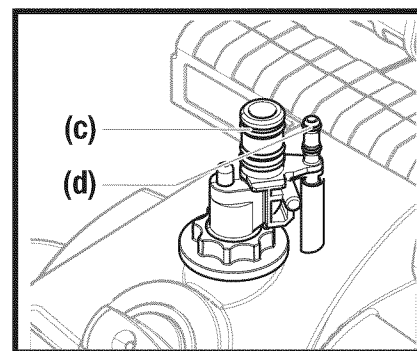

NOTE: If suction set is difficult to press onto the pump, lubricate the O-rings (c) and (d) as shown with petroleum jelly.

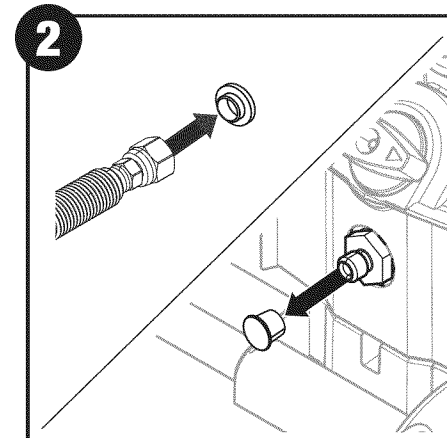

2. Remove the plug from inside the hose fitting and remove the cap on the outlet valve. Discard both.

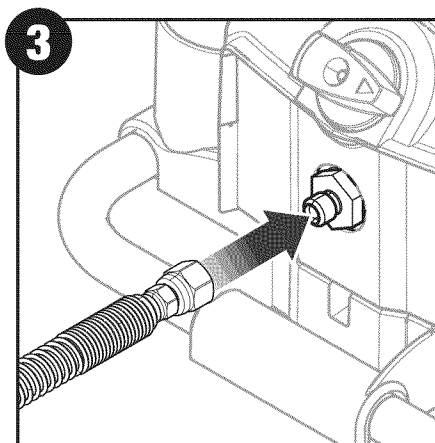

3. Thread one end of the spray hose to the outlet valve on the sprayer.

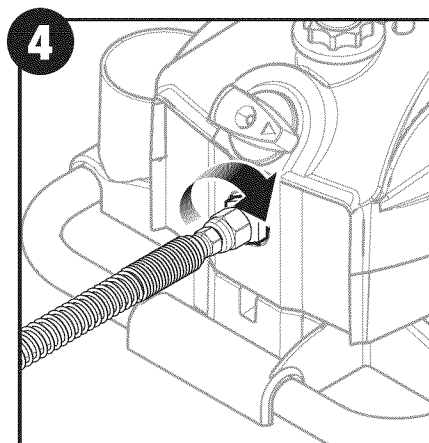

4. Tighten the hose with an adjustable wrench.

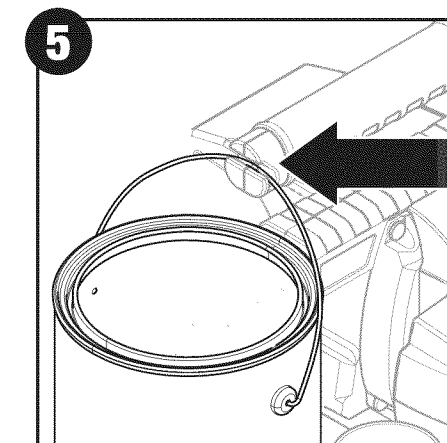

5. Hook material container onto the end of the sprayer handle as shown (round, one gallon containers only)

Proper use and functions

Specifications

Weight20.5 lbs
 Flow rate.....0.24 gal/minute
 Power source.....1/2 Hp universal motor
 Power requirement15 amp minimum circuit on 120 VAC, 60 Hz current
 Generator requirement8000 Watt
 Max. spraying pressure2800 PSI

Capability

Sprays a variety of paints (oil-based and latex), primers, stains, preservatives and other nonabrasive materials. Do not use materials with flash points below 70° F (21° C)

Do not use!

This pump should not be used with textured materials, block filler, lacquers, industrial enamels, or asphalt sealer or materials containing HHC. See coating supplier if flash point is not listed on the container

Safety features

Spray gun trigger lock and pressure diffuser; built-in tip safety guard; PRIME/SPRAY knob for safe pressure release. Conforms to ULSTD 1450. Certified to CAN/CSAC 22.2 NO 68-92

Controls and Functions

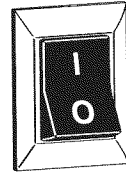

ON/OFF switch:

The ON/OFF switch turns power to sprayer on and off. (O=OFF, I=ON)

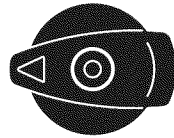

PRIME/SPRAY knob:

The PRIME/SPRAY knob directs material to the material return tube when set to PRIME or to spray hose when set to SPRAY.

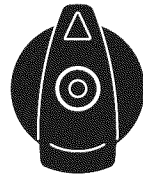

Pressure control:

The pressure control function is also controlled by the PRIME/SPRAY knob. The pressure control regulates the amount of force the pump uses to push the fluid and can be adjusted for desired spray pattern.

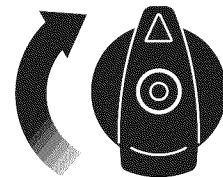

SPRAY - MINIMUM PRESSURE

Ideal for thinner spray materials. Also to be used during cleanup, when unclogging the tip, or when using the optional roller attachment.

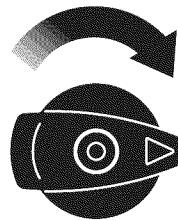

SPRAY - MAXIMUM PRESSURE

Ideal when spraying thicker materials. To be used during spraying.

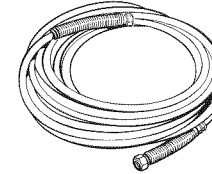

Spray hose:

The spray hose connects the spray gun to the pump.

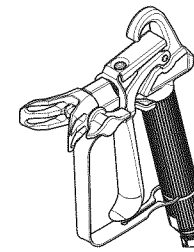

Spray gun:

The spray gun controls the delivery of the material being pumped.

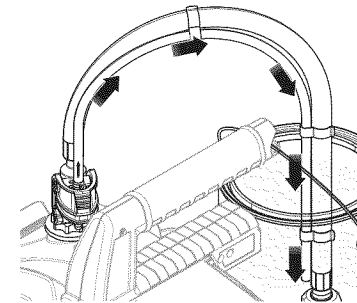

Material return tube:

Fluid is sent out through the return tube and back into the original container when the PRIME/SPRAY knob is in the PRIME position.

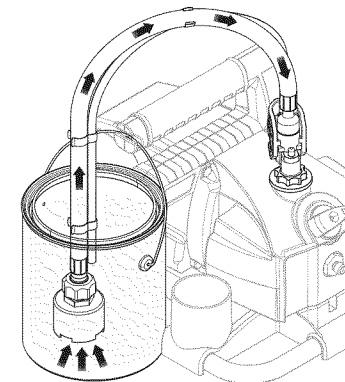

Suction tube:

The suction tube draws the fluid from the original container into the pump.

Pressure Relief Procedure*

*Perform when instructed

 Be sure to follow the Pressure Relief Procedure when shutting the unit off for any purpose. This procedure is used to relieve pressure from the spray hose. Failure to do so could result in serious injury.

You will need:

- A waste bucket

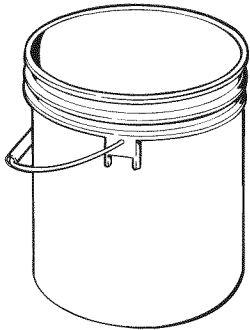

Important Safety Warning



Be careful when handling the spray gun so you don't accidentally spray yourself. The high pressure paint stream could pierce your skin causing serious injury. If an accident happens see detail procedures in the Safety Information section on pages 2-3. See physician immediately and bring this instruction manual.

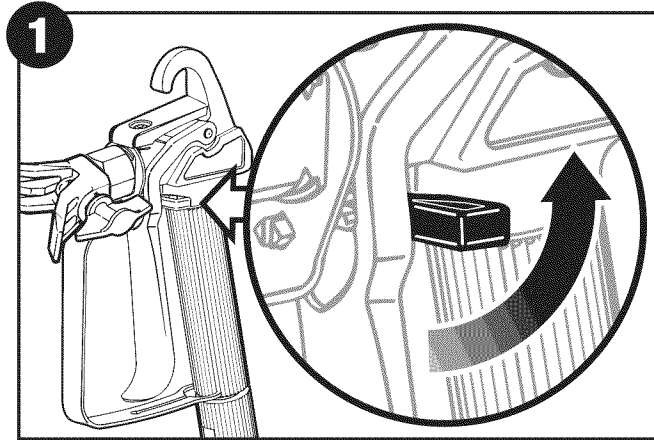
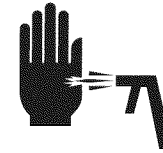

1. Lock the spray gun trigger.

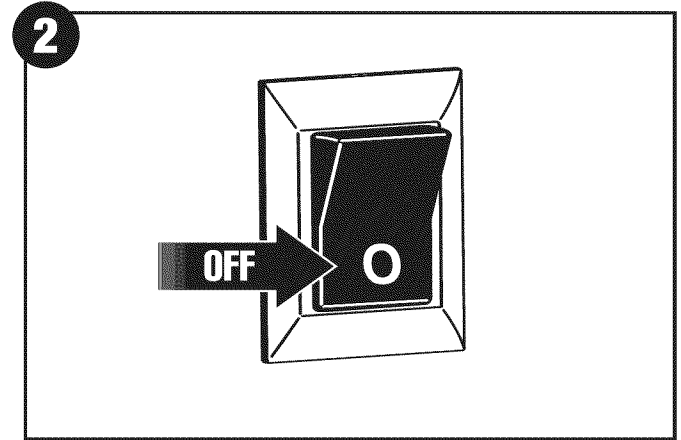

2. Turn the power OFF.

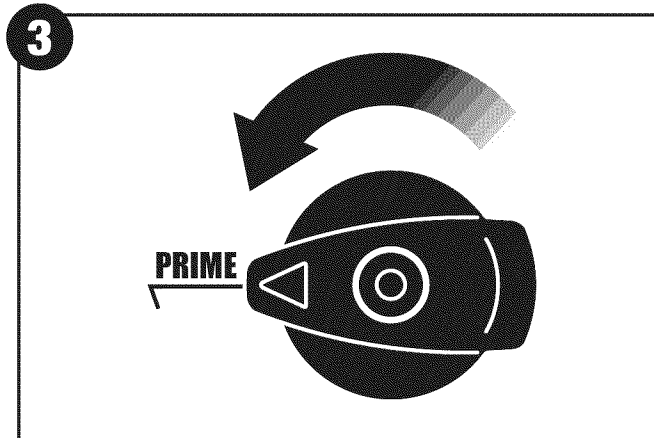

3. Turn the PRIME/SPRAY knob to PRIME.

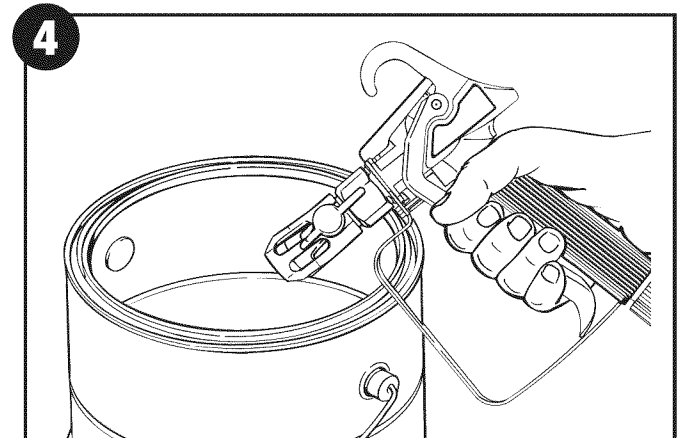

4. Unlock the spray gun. Briefly pull the trigger to fully relieve pressure from the system. Lock the spray gun.

2. Load Material

You will need:

- The material you plan to spray
- Extension cord
- Waste bucket

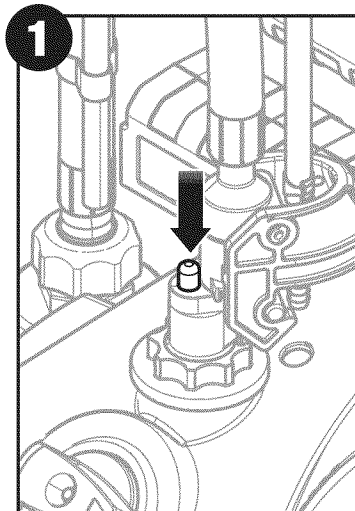
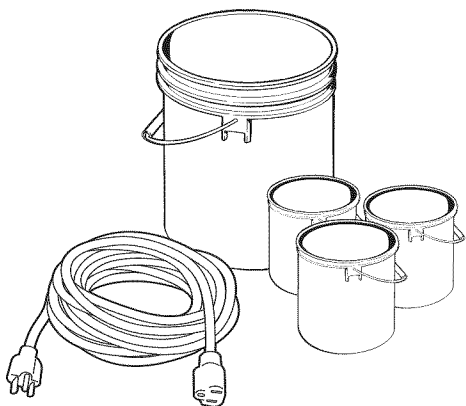

1. Push the red inlet release button to ensure proper inlet valve operation.

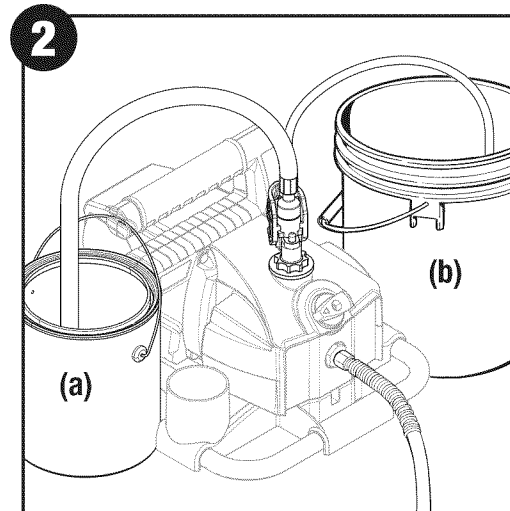

2. Unclip the suction hose and return tube. Place suction hose into material container (a). Place return tube into a waste bucket (b).

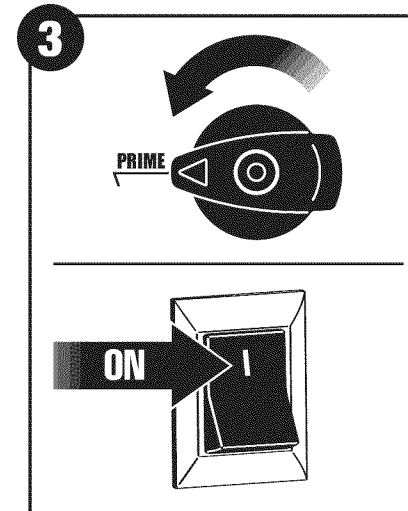

3. Plug in the sprayer. Turn the PRIME/SPRAY knob to PRIME. Turn the power ON.

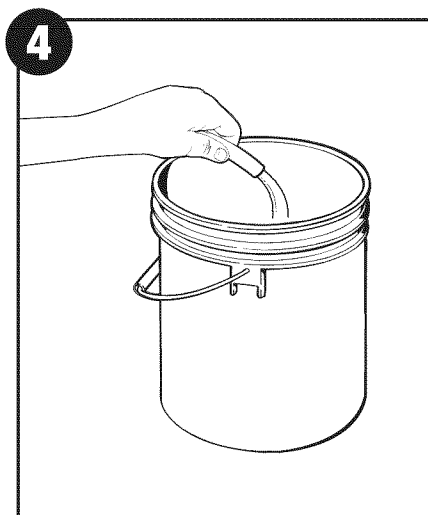

4. Hold return tube over waste bucket until material is flowing (approximately five seconds).

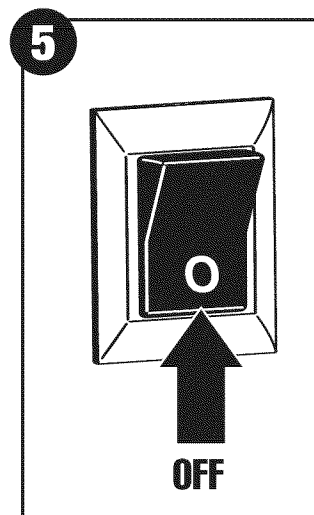

5. Turn power OFF.

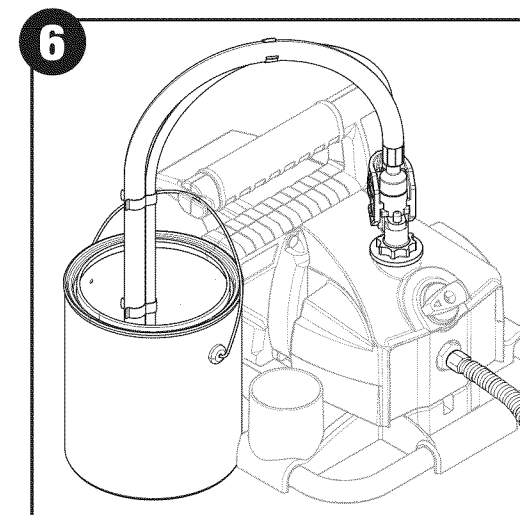

6. Place return tube into material container and clip tube and suction hose together.

3. Getting Material to Flow

You will need:

- Scrap material / cardboard
- Drop cloths to protect floors and furnishings from overspray

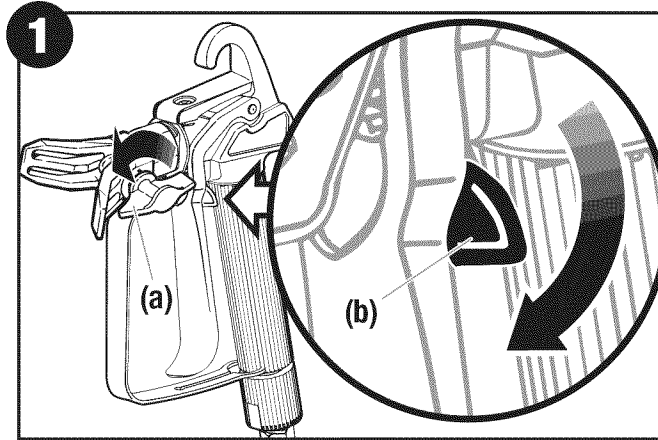

1. Rotate spray tip forward to SPRAY position (a). Unlock the spray gun trigger by turning the trigger lock down (b).

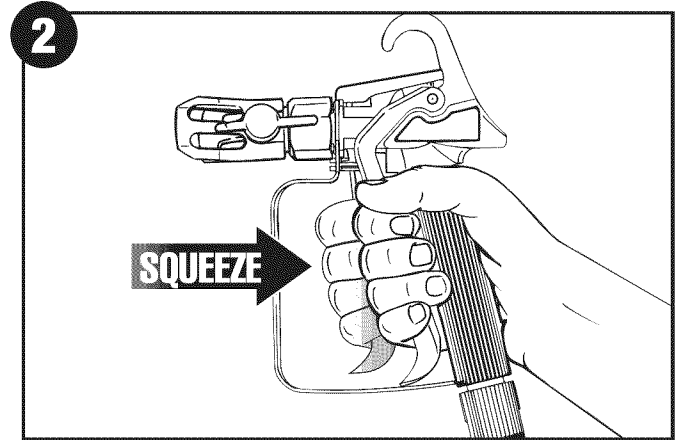

2. Point the spray gun at a piece of scrap material/ cardboard. **Squeeze and hold trigger for steps 3-5.**

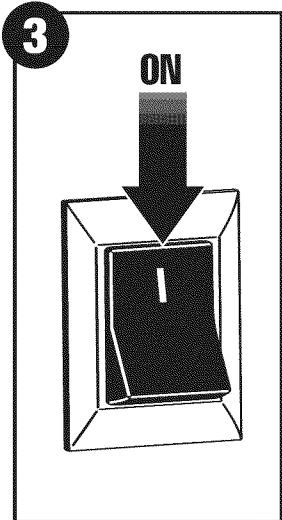

3. Turn the power ON.

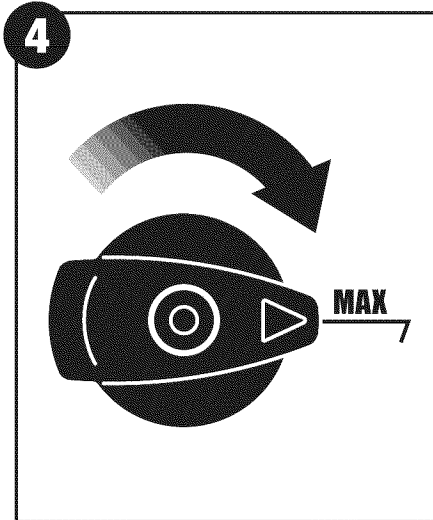

4. Turn the PRIME/SPRAY knob to SPRAY - MAXIMUM PRESSURE.

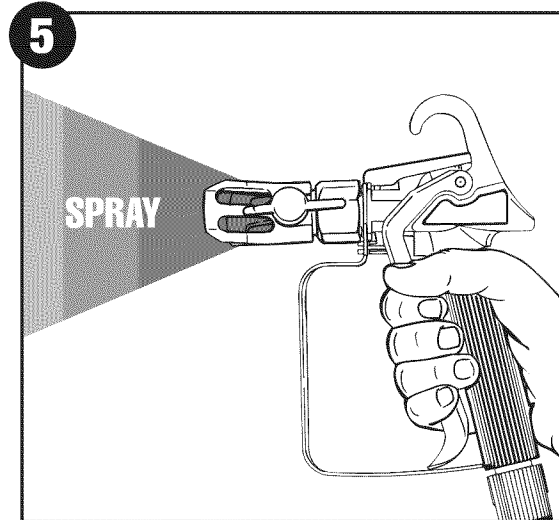

5. Continue to squeeze trigger until the material is flowing freely through the spray gun.

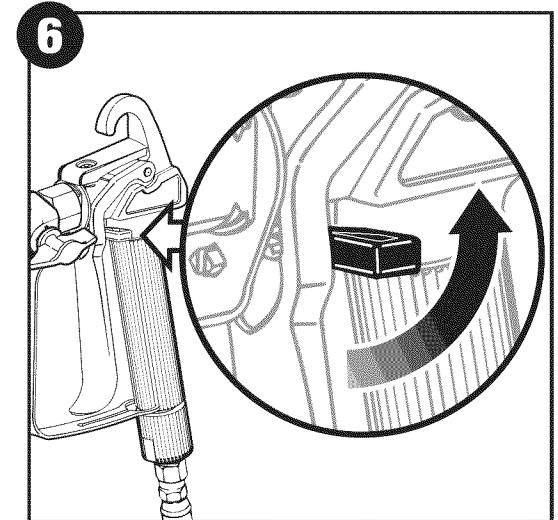

6. Release the trigger and lock the spray gun.

NOTE: Motor will cycle ON and OFF while spraying to regulate pressure. This is normal.

4. Practice Spraying

You will need:

- Scrap material / cardboard

If the spray pattern becomes distorted or stops completely while the gun is triggered, follow any or all the procedures listed on pages 12-14.

If you plan to be away from your spray project for more than one hour, follow the Short Term Storage instructions on page 15.

If you have difficulty achieving a good spray pattern, your spray tip and gun filter may not be ideal for the type of material you are spraying. Refer to the chart below and on page 75.

Spray Tip Size	Filter Color	Spray Material	Initial Pressure Setting
411	Red	Thin stains, sealers	Minimum
511			
413	Yellow	Thick latex paints, stains	Maximum
513			
415			
515			

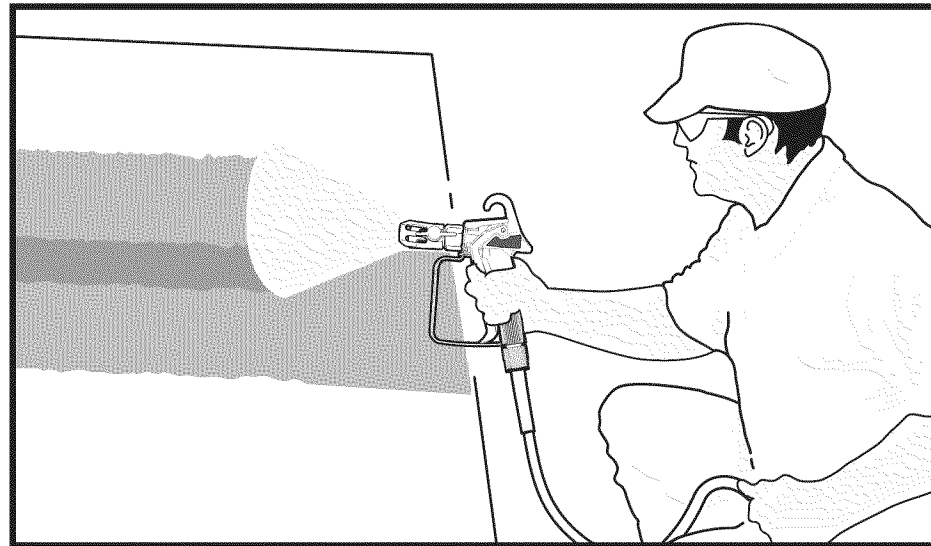

Practice on a piece of scrap material/cardboard

Tip:

Trigger gun after starting the stroke. Release the trigger before ending the stroke. The spray gun should be moving when the trigger is pulled and released. Overlap each stroke by about 30%. This will ensure an even coating.

Hold the Spray Gun Level

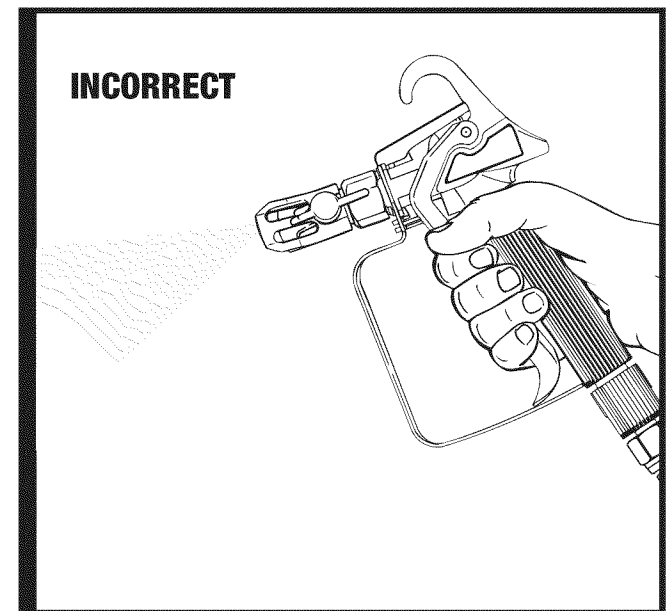
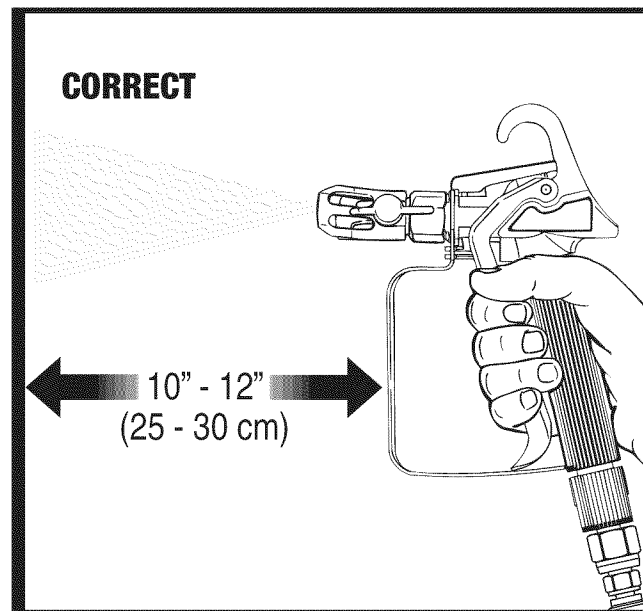

Spray Technique

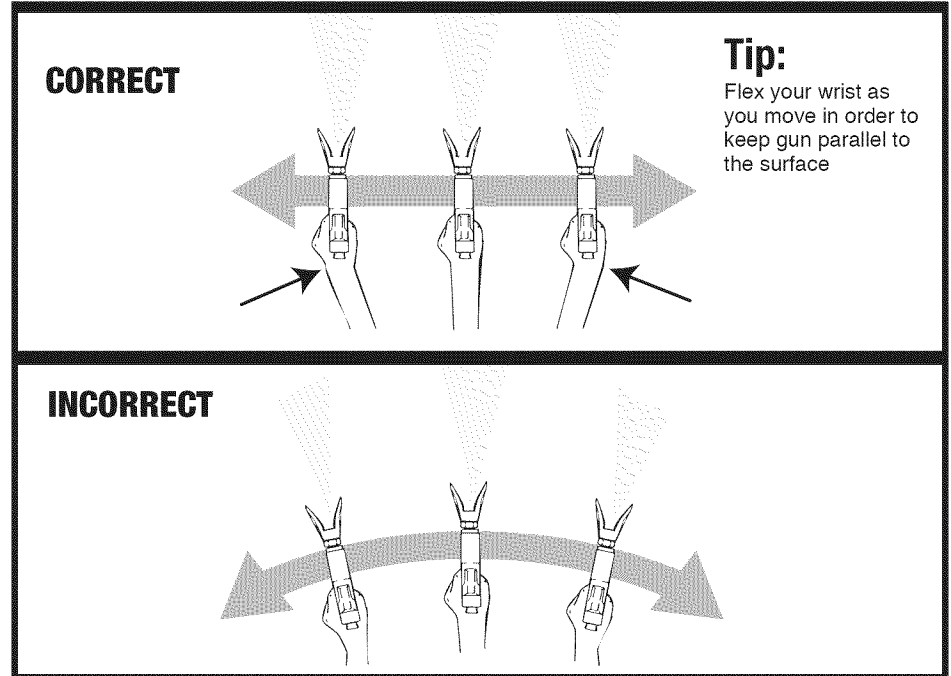
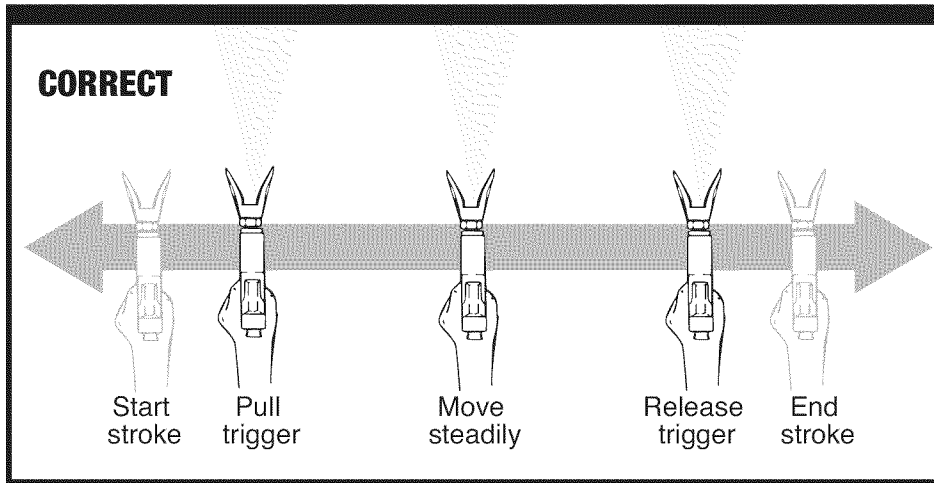

Spray Pattern

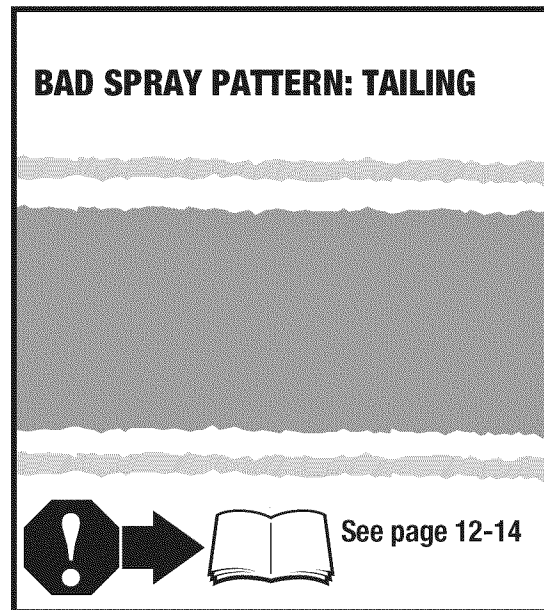
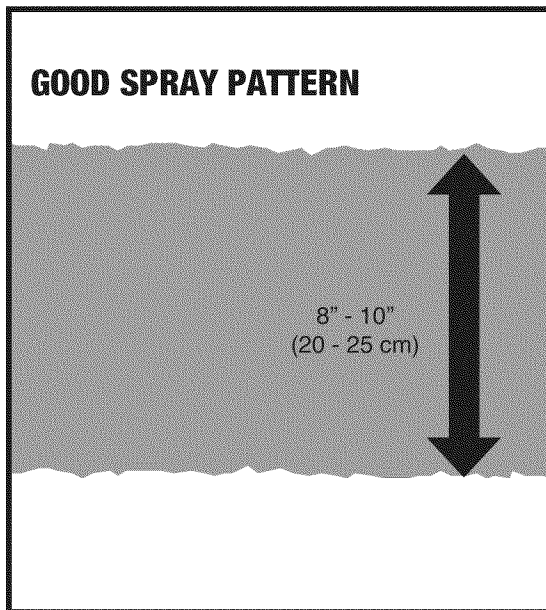

Overlap Your Strokes

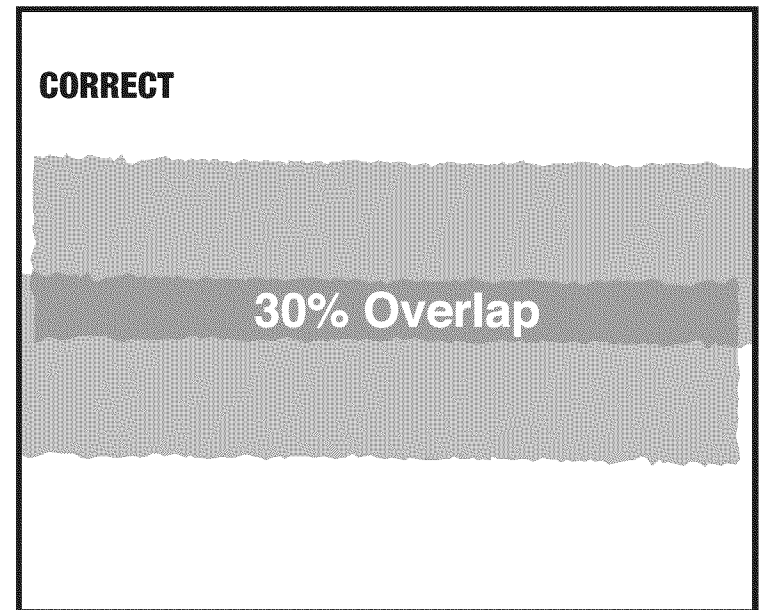

Spraying Troubleshooting - Clear the Spray Tip



You will need:

- Scrap material / cardboard



Do not attempt to unclog or clean the tip with your finger. High pressure fluid can cause injection injury.

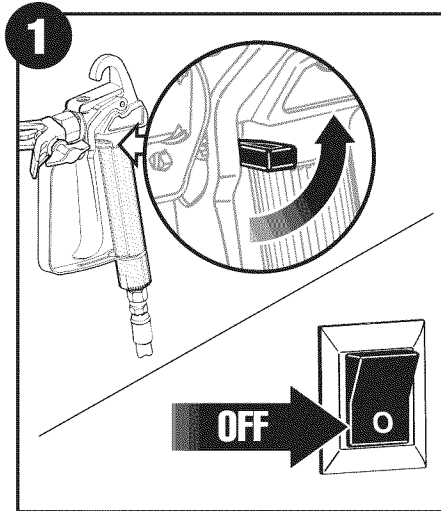

1. Lock the spray gun. Turn the power OFF.

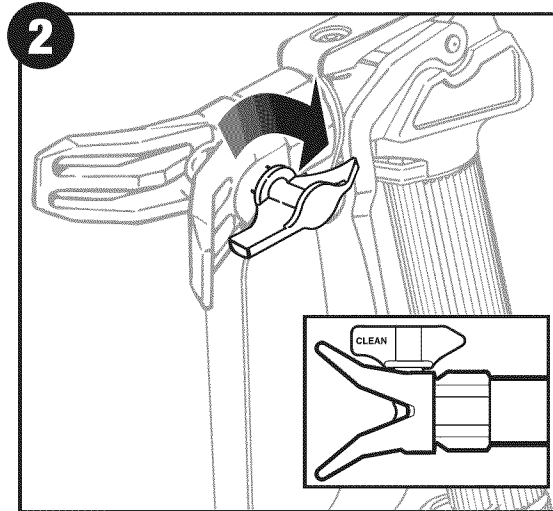

2. Rotate reversible spray tip 180 degrees to **CLEAN** position (arrow pointing toward the rear of the spray gun).

Note: If spray tip is difficult to rotate, relieve pressure by turning PRIME/SPRAY knob to PRIME and squeeze trigger while pointing at scrap material / cardboard. Release trigger and try rotating spray tip again.

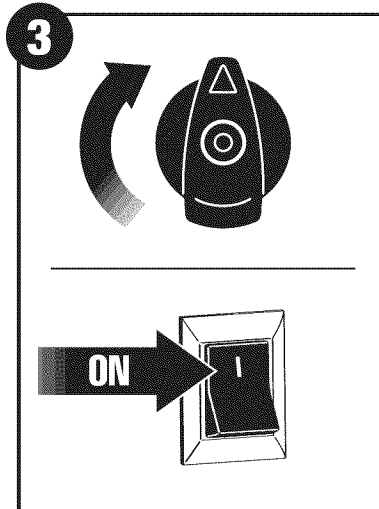

3. Turn the PRIME/SPRAY knob to SPRAY - MINIMUM PRESSURE. Turn power ON.

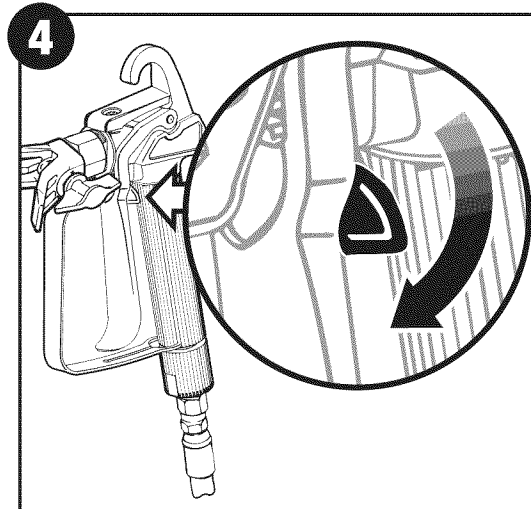

4. Unlock the spray gun.

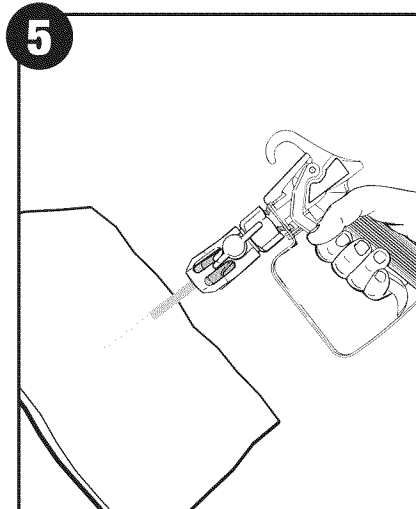

5. Point at a piece of scrap material / cardboard and squeeze trigger until material comes out in a high pressure stream. Release the trigger and lock the spray gun.

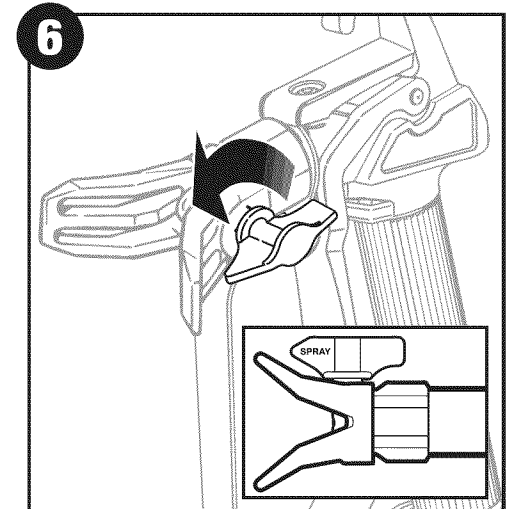

6. Reverse the spray tip so the arrow points forward. Resume spraying.

Spraying Troubleshooting - Clean the Spray Gun Filter



You will need:

- Wrench
- Warm, soapy water for latex material
- Mineral spirits for oil based materials
- Replacement spray gun filter (if necessary)

IMPORTANT: Never clean the filter by poking it with a sharp object.

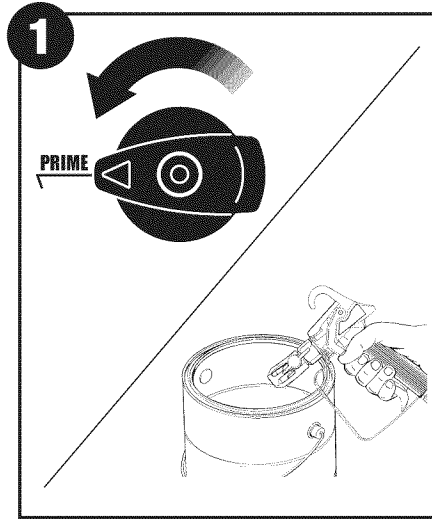

1. Perform the **Pressure Relief Procedure**, page 7.

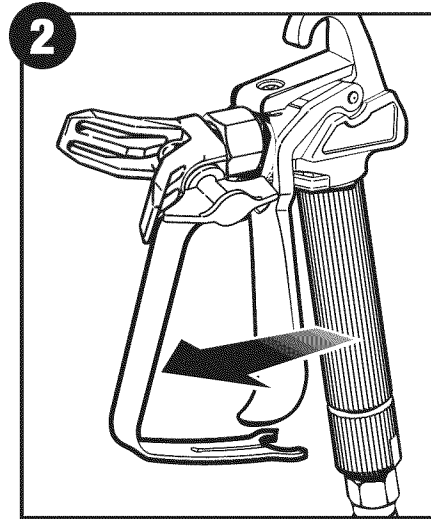

2. Pull trigger guard from filter housing.

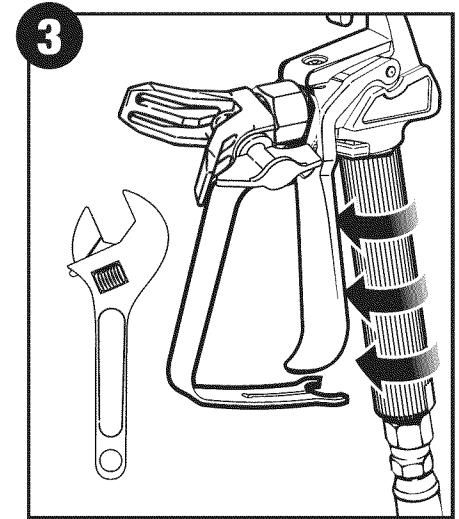

3. Unscrew the filter housing using a wrench.

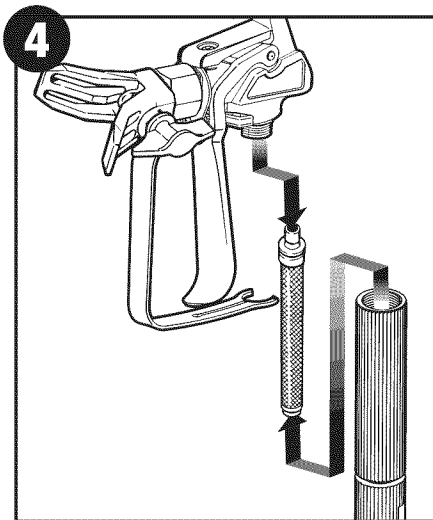

4. Remove the filter from the housing. Clean with appropriate cleaning solution (warm, soapy water for latex materials; mineral spirits for oil-based materials).

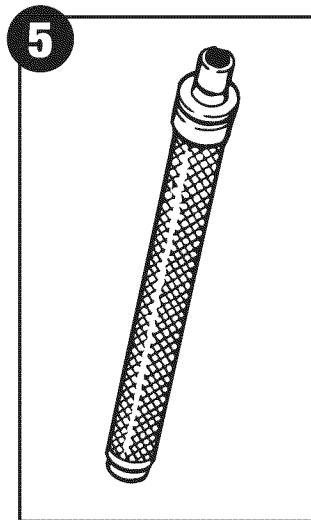

5. Inspect the filter for damage. Replace if any holes or tears are found.

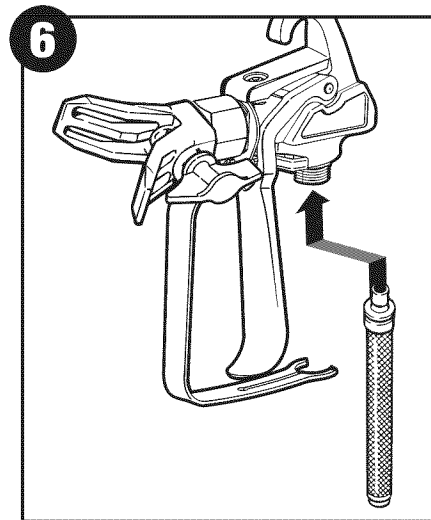

6. Replace cleaned filter, tapered end first, into the gun housing.
Note: It is important to place tapered end first to ensure proper sprayer operation.

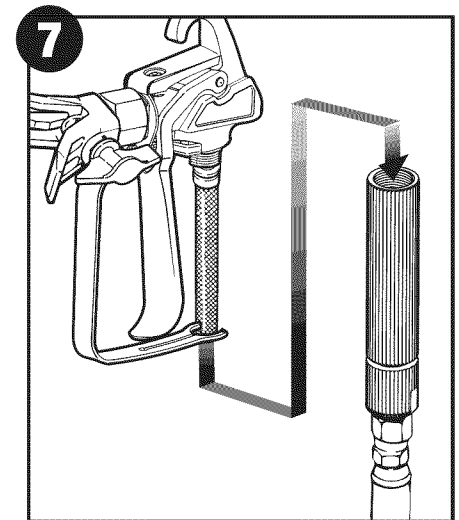

7. Reassemble the spray gun.

Spraying Troubleshooting - Clean the Inlet Filter

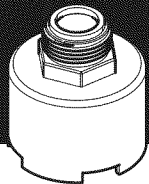

You will need:

- Warm, soapy water for latex material
- Mineral spirits for oil based materials

IMPORTANT: Make sure your floors and furnishings are covered with drop cloths to prevent accidental drips.

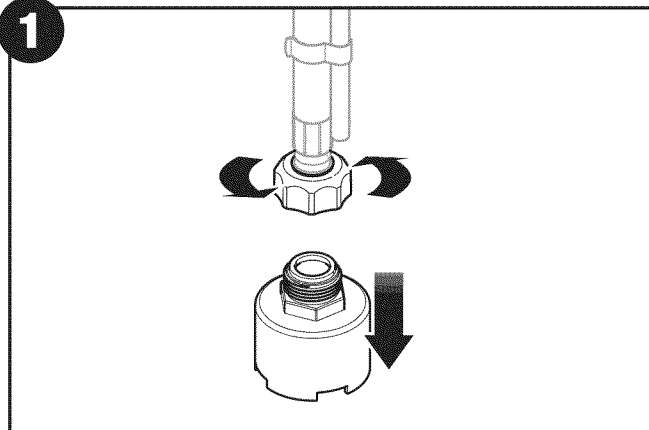

1. Unscrew the inlet filter from the fitting on the end of the suction tube.

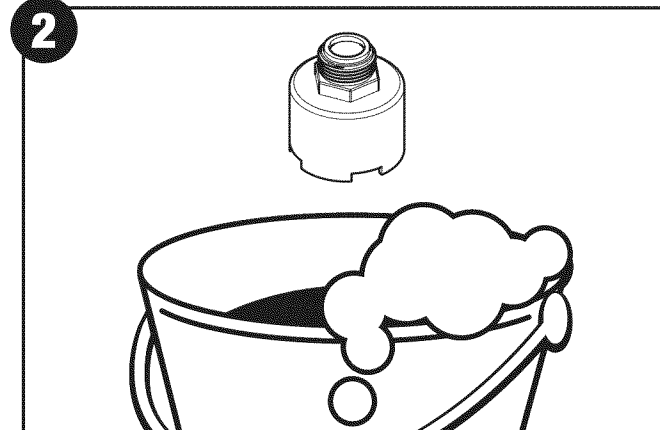

2. Clean the filter using the appropriate cleaning solution (warm, soapy water for latex materials, mineral spirits for oil-based materials).

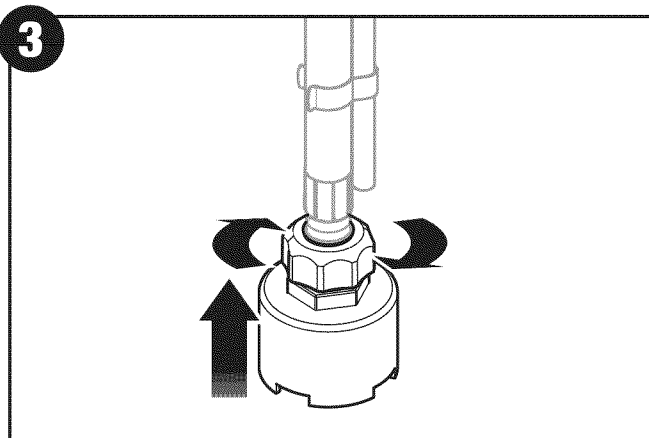

3. Replace the cleaned filter by threading it back into the fitting on the end of the suction tube.

Short Term Storage

This procedure should be used when taking a short term break or when ending your project for the day. If your break is longer than 16 hours follow Cleanup instructions, page 16.

You will need:

- Water
- Plastic bag or bucket
- Rags
- Stir stick

Instructions are for latex materials only

Note: If using oil based material follow instructions for Cleanup on page 16.

Shutdown

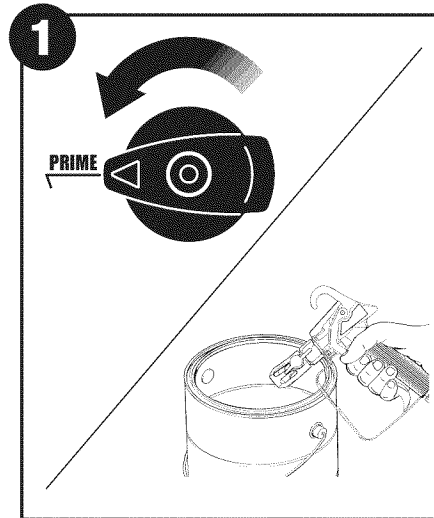

1. Perform the Pressure Relief Procedure, page 7.

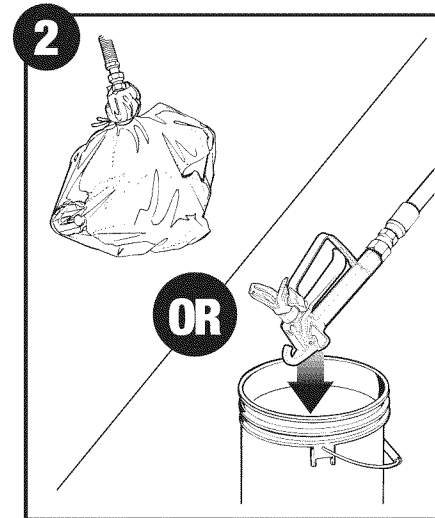

2. Place spray gun in plastic bag or immerse into bucket of water.

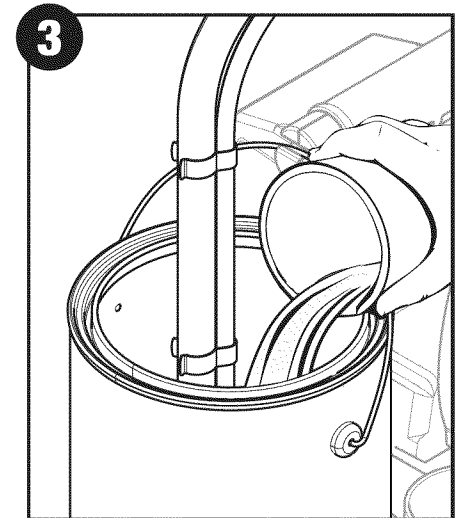

3. Pour 1/2 cup water slowly on the top of the paint to prevent the paint from drying. Place the entire spraying system out of the sun.

Startup

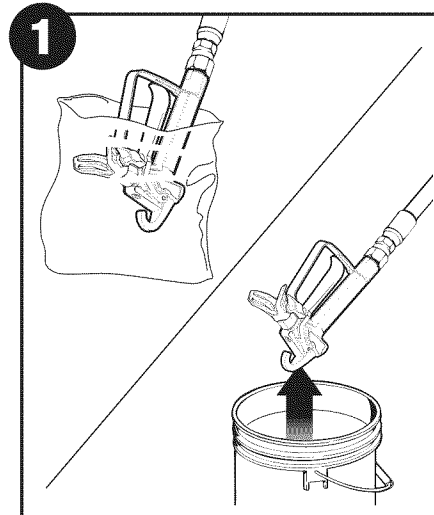

1. Remove the spray gun from the plastic bag or the water.

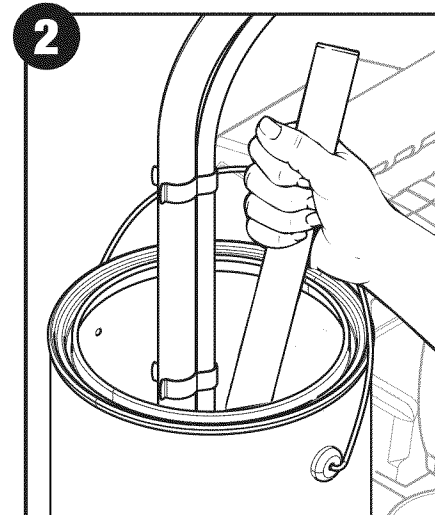

2. If water was added during shutdown, stir water into material with the stir stick.

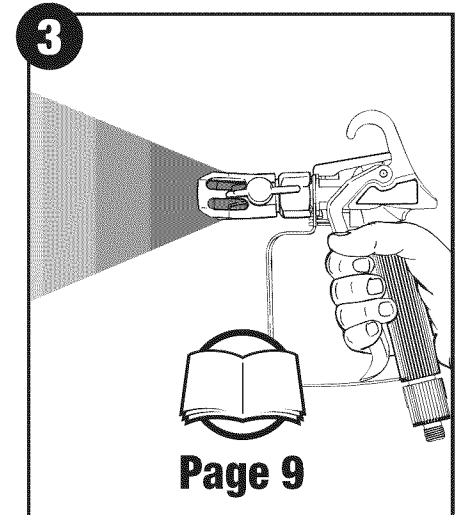

3. Follow Getting Material to Flow instructions, page 9.

Cleanup



or



You will need:

- A water source that can be delivered with a garden hose (latex materials only)
- Mineral spirits if using oil-based material
- Empty waste container
- A container with warm, soapy water

Cleaning notes - read before cleaning

- When using latex material, clean sprayer and components with warm, soapy water. For oil based material use mineral spirits. Never use mineral spirits with latex materials
- NEVER use gasoline to clean sprayer
- Dispose of used cleaning solution properly
- Thorough cleaning and lubrication of sprayer is important to ensure proper operation after storage
- If you flush your sprayer with mineral spirits, repeat **Cleanup** instructions using warm, soapy water.

Follow these steps whenever cleaning with mineral spirits:

- If spraying or cleaning with oil-based materials, the spray gun must be grounded while preparing the spray hose or cleaning.
- Ground the gun by holding it against the edge of a metal container while purging. Failure to do so may lead to a static electric discharge which may cause a fire.
- Always flush spray gun at least one hose length from spray pump.
- If collecting flushed solvent in one gallon metal container, place it into an empty five gallon container, then flush.
- Area must be free from vapors.
- Follow all cleanup instructions.

Cleanup - Latex materials

Follow these steps if you used latex materials and if you have a garden hose available. If you do not have a garden hose available, follow the **Cleanup - Oil-Based Materials** instructions on page 18.

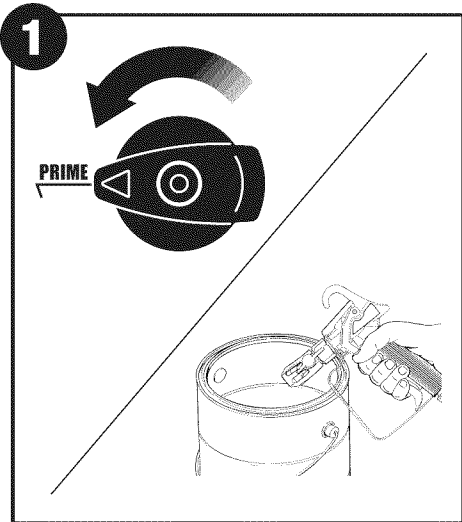

1. Perform **Pressure Relief Procedure** (page 7).

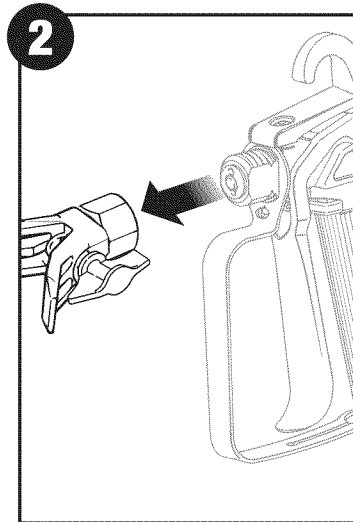

2. Remove the spray tip and place into container filled with warm, soapy water.

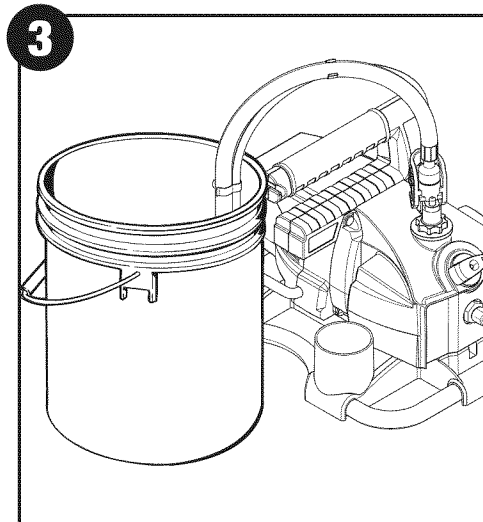

3. Place the suction tube and return tube into an empty waste container.

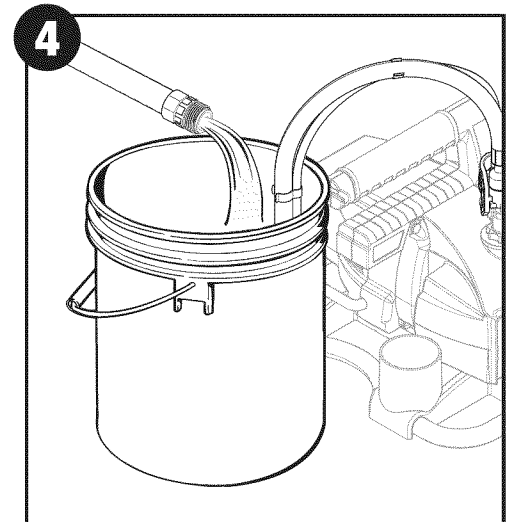

4. Using a garden hose, rinse off the suction tube, return tube and inlet filter. Empty the waste container of all fluids.

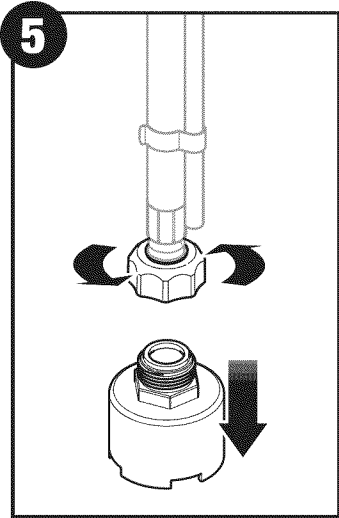

5. Remove the inlet filter from the suction tube and place it into waste container.

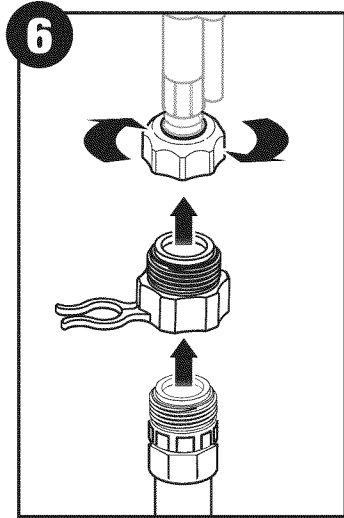

6. Thread pump cleaning adapter onto garden hose. Thread suction tube fitting over the adapter.

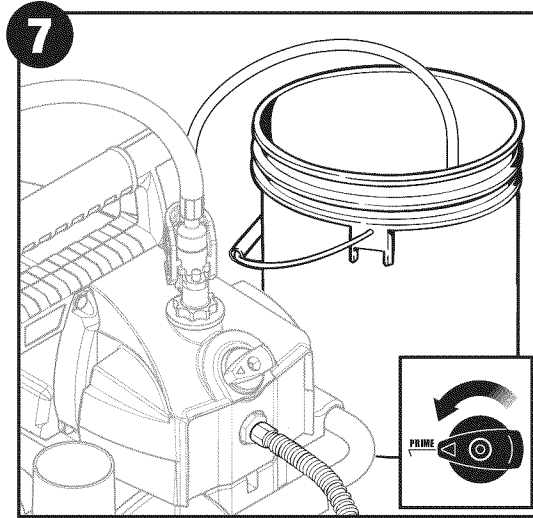

7. Unclip the return tube from the suction tube and place it into the waste container. Turn the PRIME/SPRAY knob to PRIME.

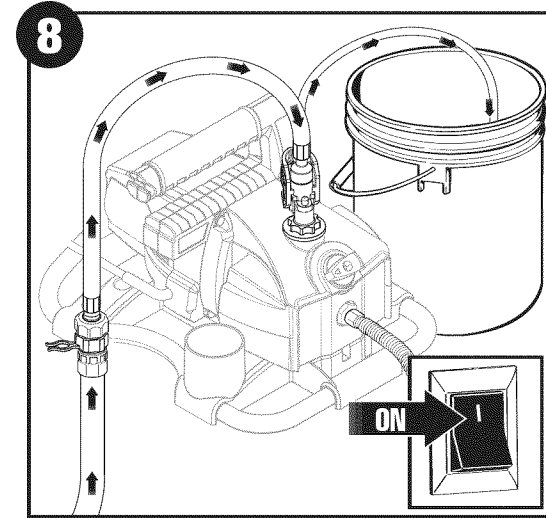

8. Turn the water supply to the garden hose on. Turn the pump ON. Water will go into the suction tube and out through the return tube. Let the pump run for a few minutes, and leave pump running for next steps.

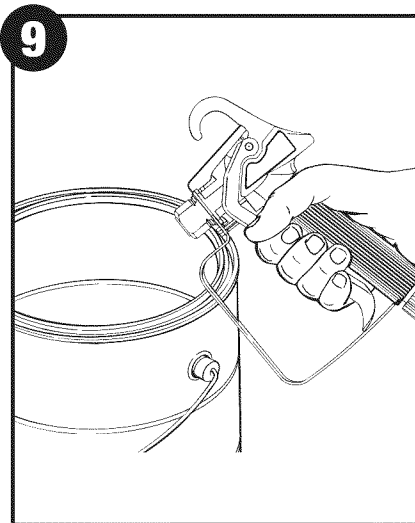

9. Point the spray gun at the side of a waste container.

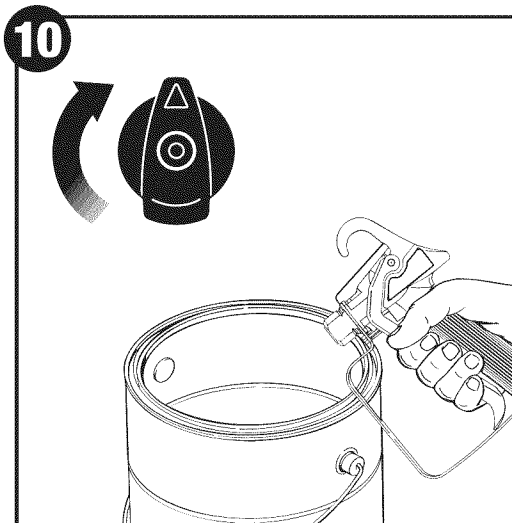

10. While squeezing the trigger, turn the PRIME/SPRAY knob to SPRAY - MINIMUM PRESSURE.



11. Continue squeezing the trigger until fluid is coming out clear.

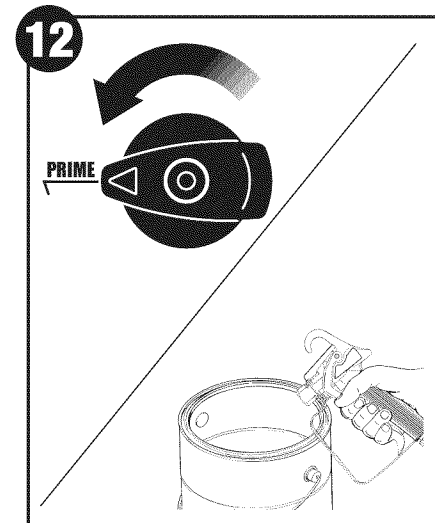

12. Perform **Pressure Relief Procedure**, page 7.

Cleanup - Oil-Based Materials

Follow these steps if you sprayed oil-based materials, or if you sprayed latex materials and do not have a garden hose available. Be sure to use the appropriate cleaning solution for the type of material sprayed.

You will need:

- Mineral spirits if using oil-based material
- Warm, soapy water if using latex material
- Waste container

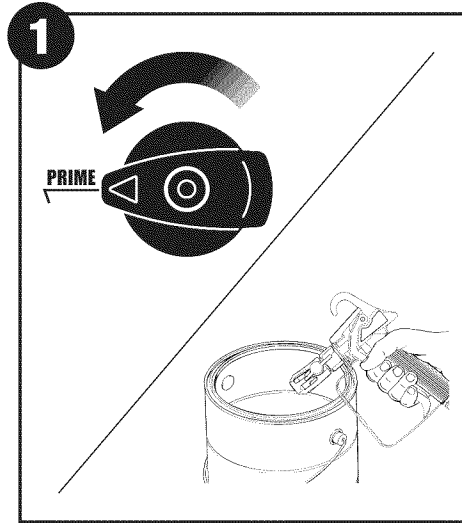

1. Perform **Pressure Relief Procedure** (page 7).

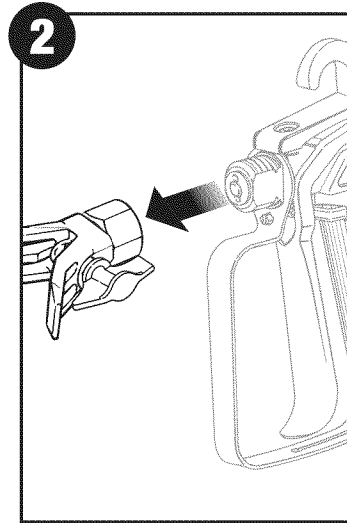

2. Remove the spray tip and place into an empty waste container.

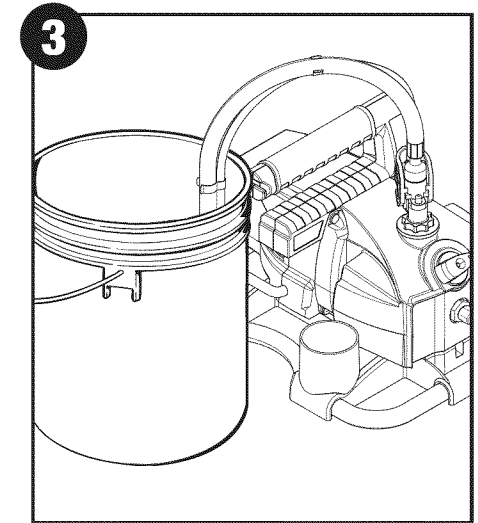

3. Submerge suction set into a bucket with the appropriate cleaning solution.

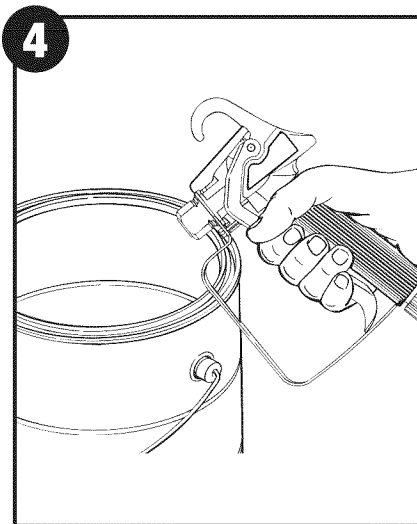

4. Point the spray gun at the side of a waste container. **Ground the gun against the side of a metal waste container if flushing with mineral spirits.**

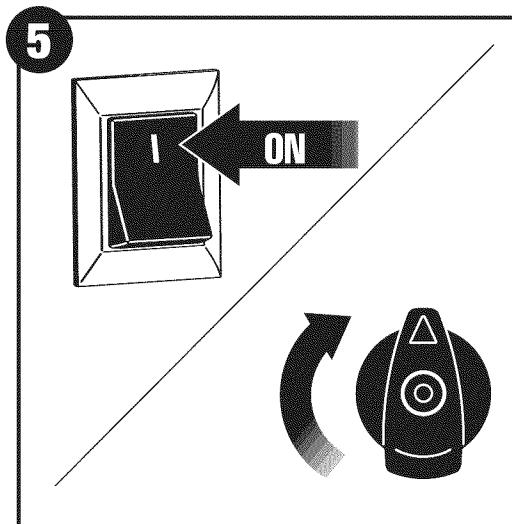

5. While squeezing the trigger, turn the power ON, and turn the PRIME/SPRAY knob to **SPRAY - MINIMUM PRESSURE**.



6. Continue squeezing the trigger until fluid is coming out clear. You may need to get new cleaning solution.

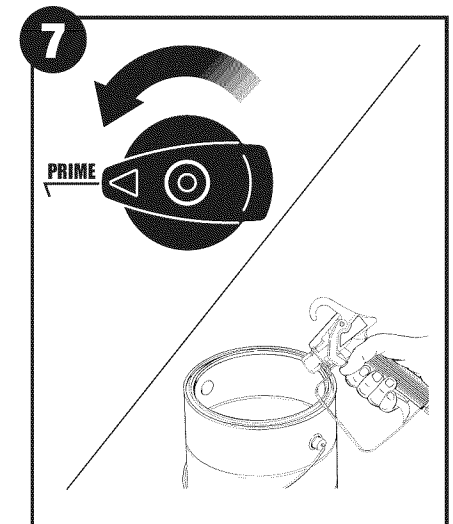

7. Perform **Pressure Relief Procedure**, page 7.

If you flushed the sprayer with mineral spirits repeat the steps on this page using warm, soapy water.

Cleaning the Spray Gun Components

You will need:

- Soft bristled brush
- Light household oil
- Warm, soapy water if using latex material
- Mineral spirits for oil based material
- Wrench

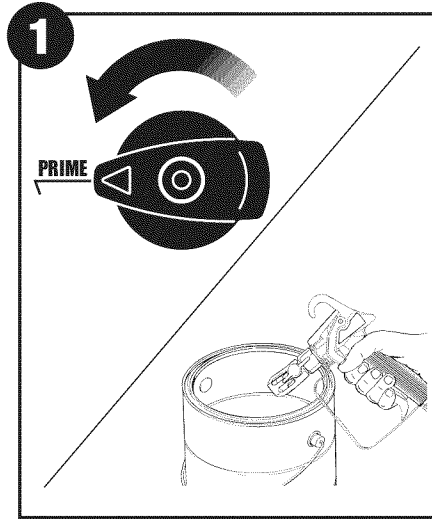

1. Perform the **Pressure Relief Procedure**, page 7.

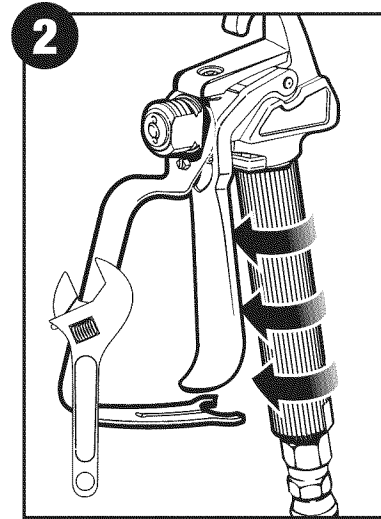

2. Pull trigger guard to separate from filter housing and unscrew housing using a wrench

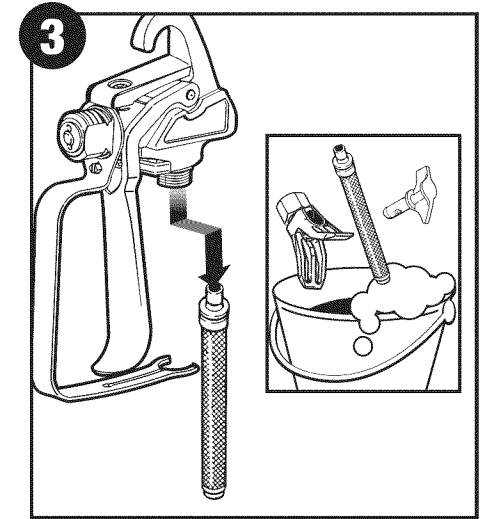

3. Remove filter from spray gun. Clean spray tip and filter with soft bristled brush and appropriate cleaning solution

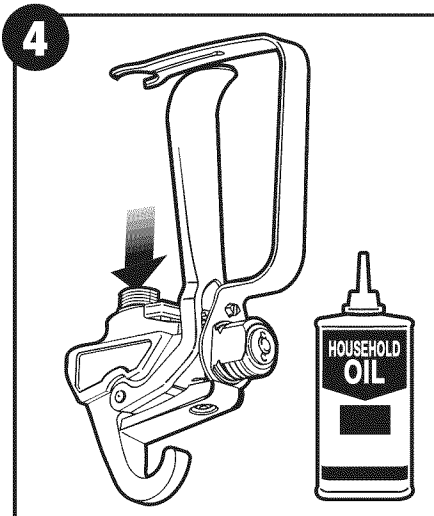

4. Pour a few drops of light household oil inside gun housing.

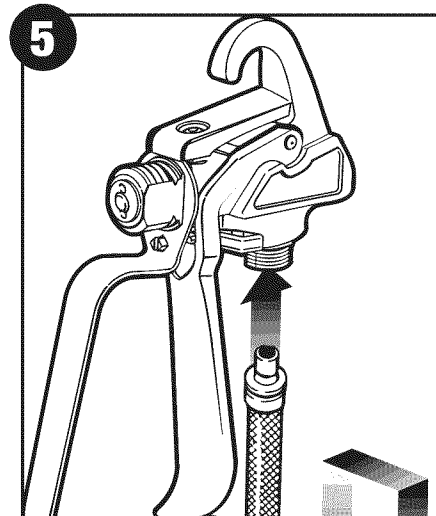

5. Install gun filter tapered-end first. Reassemble spray gun.

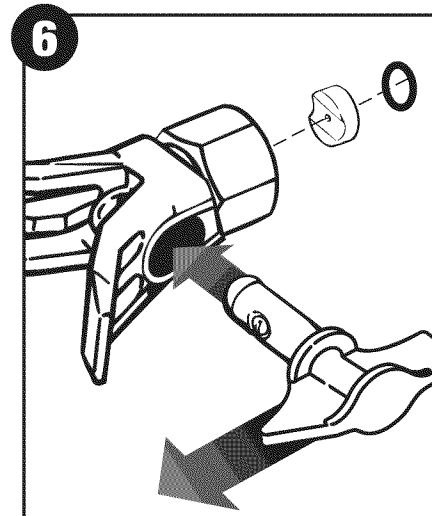

6. Install spray tip with arrow pointing towards front of spray guard tip.

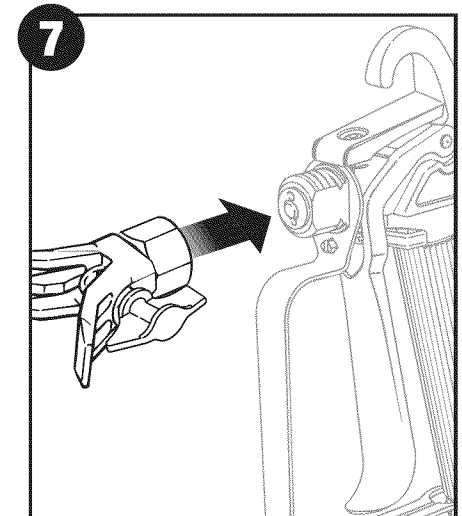

7. Install spray tip and guard assembly.

Long Term Storage



You will need:

- Light household oil
- Rags

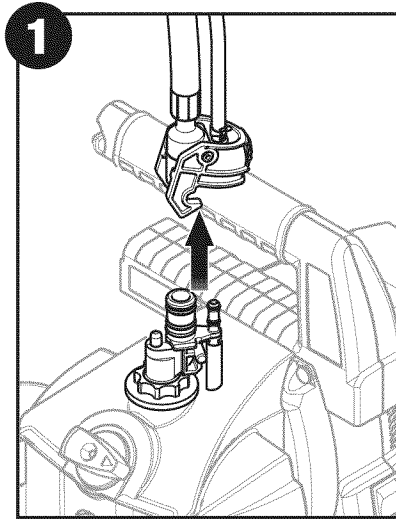

1. Remove the suction set.

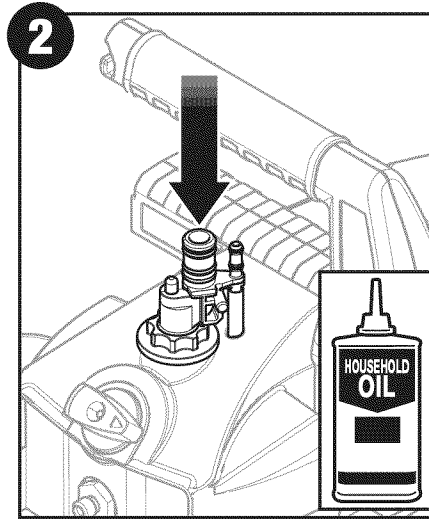

2. Pour approximately 2 ounces of light household oil into the pump inlet.

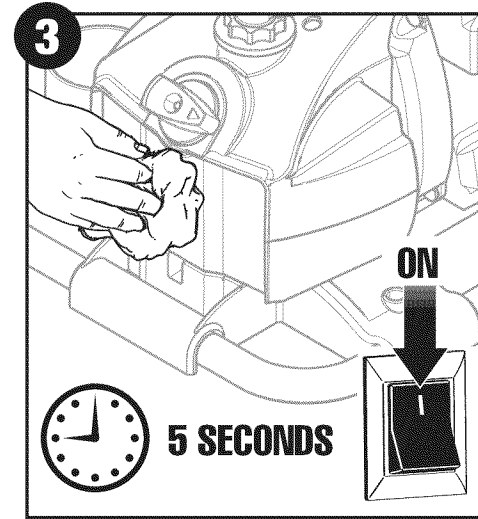

3. Cover the outlet valve with a rag. Turn power ON and let the pump run for five seconds.

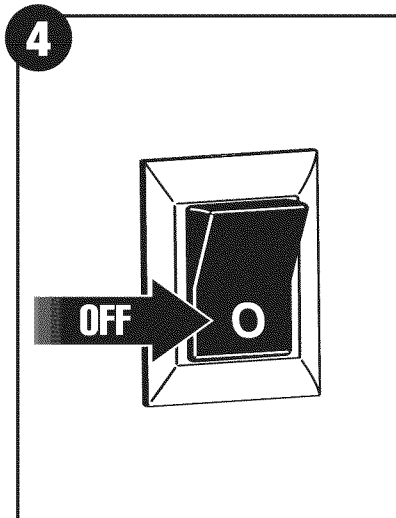

4. Turn power OFF.

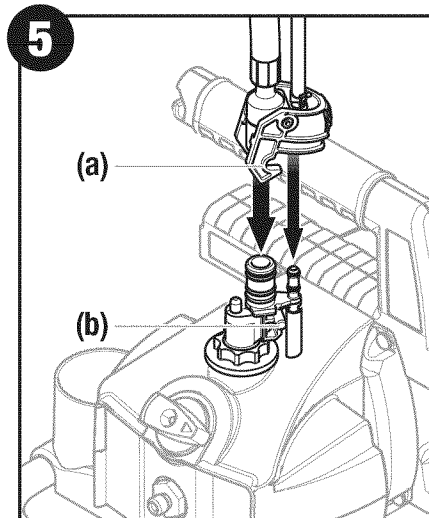

5. Replace suction set. Make sure the connector notches (a) snap over the pins (b) on the pump inlet.

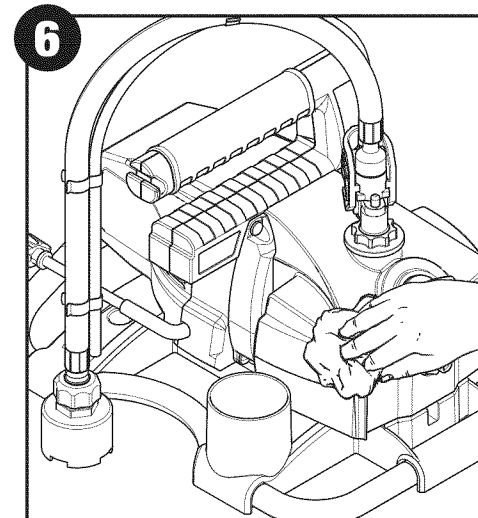

6. Wipe entire unit, hose, and spray gun to remove accumulated spray material.

Replacing Outlet Valve

Replacement of the outlet valve may be necessary if spray performance remains poor after following steps in the Fix Spraying Problems section. Replacement valves can be ordered by calling the customer service number found on page 4

You will need:

- Wrench
- Rag
- Warm, soapy water if using latex material
- Mineral spirits for oil based material

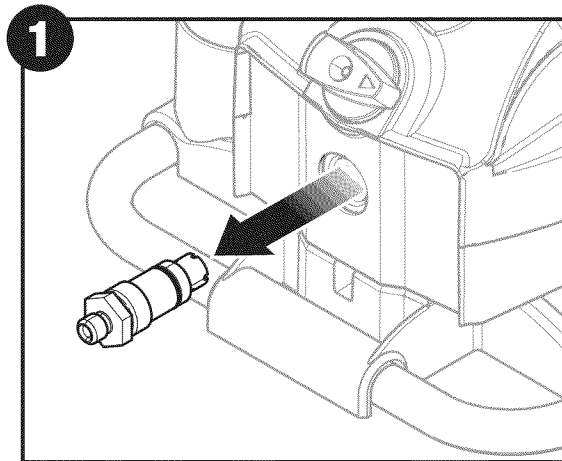

1. Unscrew outlet valve from outlet valve housing using wrench.
2. Remove any accumulated material inside outlet valve housing using appropriate solution for material being used.
3. Replace with new outlet valve and tighten with wrench.

Cleaning or Replacing Inlet Valve

Cleaning or replacing the inlet valve may be necessary if spray performance remains poor after following steps in the Fix Spraying Problems section. Problems with the inlet valve are usually caused by improper cleaning or storage. Replacement kits may be ordered by calling the customer service number found on page 4

You will need:

- Inlet valve tool
- Ratchet wrench, extension
- Household oil
- Warm, soapy water if using latex material
- Mineral spirits for oil-based materials

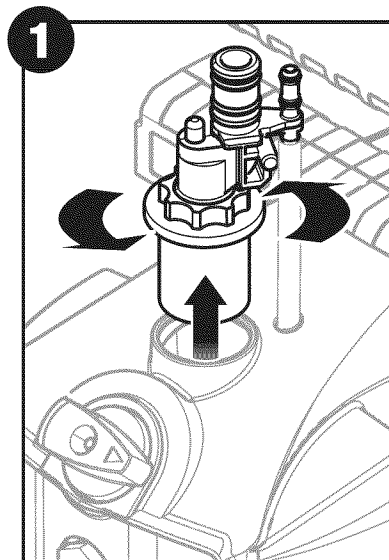

1. Remove pump inlet from the sprayer by twisting it counterclockwise.

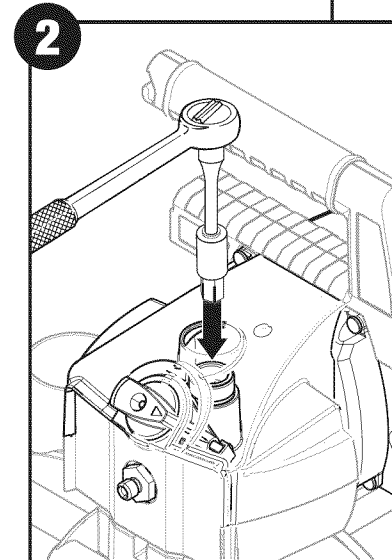

2. Insert the inlet valve tool into the inlet valve fitting. Using the ratchet and socket, twist counter-clockwise and remove from its housing.

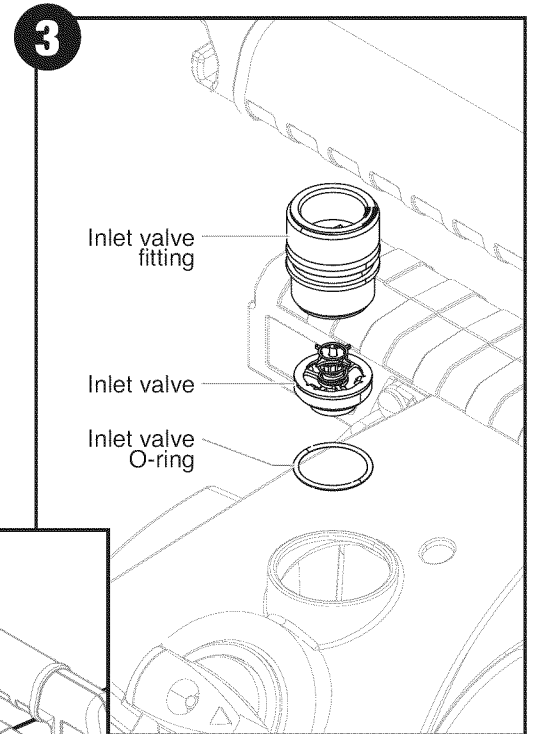

3. Retrieve the inlet valve and the inlet valve O-ring from the inlet valve housing. Clean or replace and lubricate the O-ring with a light household oil.
4. Set the inlet valve O-ring back into the housing, and set the inlet valve on top of it.
5. Replace inlet fitting into the housing. Tighten with the inlet valve tool and ratchet.
6. Replace pump inlet.

Troubleshooting



Before servicing, always release system pressure by following Pressure Relief Procedure (page 7).

Problem A: The sprayer does not start

Cause	Solution
1. Sprayer is not plugged in	Plug sprayer in
2. ON/OFF switch is set to OFF	Turn ON/OFF switch to ON
3. The sprayer shuts off while under pressure	Motor will cycle ON and OFF while spraying to regulate pressure. This is normal
4. No voltage is coming from wall plug	Test the power supply voltage
5. The extension cord is damaged or has too low a capacity	Replace extension cord
6. There is a problem with sprayer motor	Take sprayer to Wagner Authorized Service Center

Problem B: The sprayer starts but does not draw material when the PRIME/SPRAY knob is set to PRIME

Cause	Solution
1. The sprayer will not prime properly or has lost prime	Refer to Getting Material to Flow section see page 9
2. The material container is empty	Refer to Load Material and Getting Material to Flow sections see pages 8-9
3. The inlet filter is clogged	Refer to Clean the Inlet Filter see page 14
4. The inlet valve is stuck	Inlet may be stuck from old material. Push red inlet release button to release. If still stuck refer to Clean the Inlet Filter see page 14 or Replace the Inlet Valve see page 21 *
5. The outlet valve is stuck	Refer to Replacing Outlet Valve see page 21
6. The inlet valve is worn or damaged	Refer to Cleaning or Replacing Inlet Valve see page 21 *
7. The PRIME/SPRAY valve is plugged	Take sprayer to Wagner Authorized Service Center

Problem C: The sprayer draws up material but the pressure drops when the gun is triggered (bad spray pattern)

Cause	Solution
1. Pressure too low	Turn PRIME/SPRAY knob to SPRAY - MAXIMUM PRESSURE
2. The spray tip is worn	Replace spray tip with a new one**
3. The inlet filter is clogged	Refer to Clean the Inlet Filter see page 14
4. The spray tip is plugged	Refer to Clear the Spray Tip see page 12
5. The spray gun filter is clogged	Refer Clean the Spray Gun Filter see page 13 . Keep extra filters on hand
6. The material is too heavy or coarse	Thin or strain the material
7. The outlet valve assembly is dirty or worn	Refer to Replacing Outlet Valve see page 21 *
8. The inlet valve assembly is damaged or worn	Refer to Clean or Replace Inlet Valve see page 21 *

Problem D: The PRIME/SPRAY knob is set to SPRAY and there is flow through the material return tube

Cause	Solution
1. The PRIME/SPRAY valve is dirty or worn	Take sprayer to Wagner Authorized Service Center

Problem E: The spray gun leaks

Cause		Solution
1.	Gun filter housing is loose	Tighten handle
2.	Internal parts of spray gun are worn or dirty	Take sprayer to Wagner Authorized Service Center

Problem F: The spray tip assembly leaks

Cause		Solution
1.	The spray tip was assembled incorrectly	Check tip assembly and assemble properly see page 20, steps 6-7
2.	Gun seal is worn	Replace the seal*

Problem G: The spray gun will not spray

Cause		Solution
1.	The spray tip plugged	Refer to Clear the Spray Tip see page 12
2.	The spray gun filter is clogged	Refer to Clean the Spray Gun Filter see page 13 . Keep extra filters on hand
3.	The spray tip is in CLEAN position	Rotate spray tip to SPRAY position see page 12, step 6
4.	PRIME/SPRAY knob not set on SPRAY	Turn PRIME/SPRAY knob to SPRAY see page 9 Getting Material to Flow

Problem H: The spray pattern is poor (tailing)

Cause		Solution
1.	Pressure too low	Turn PRIME/SPRAY knob to SPRAY - MAXIMUM PRESSURE
2.	The spray tip is plugged	Refer to Clear the Spray Tip see page 12
3.	The inlet filter is clogged	Refer to Clean the Inlet Filter see page 14
4.	The spray gun filter is clogged	Refer to Clean the Spray Gun Filter see page 13 . Keep extra filters on hand
5.	The spray tip is worn	Replace the spray tip
6.	The material is too thick	Thin material using appropriate thinning solution
7.	Pressure loss	Refer to Causes and Solutions for Problem C

* Special repair kits with instructions are available for these procedures. Refer to the **Maintenance** section of this manual for a list of the kits and their part numbers

** Additional parts are available for this procedure. Refer to the **Parts List** (page 74) section of this manual for a list of the parts and their part numbers

Daily Maintenance

The only daily maintenance necessary is thorough cleaning. Follow the cleaning procedures in this manual

Extended Maintenance

Some pump parts eventually wear out from use and must be replaced. The following is a list of available repair kits. Pump performance is the only reliable indicator of when to replace wear parts. Refer to the Troubleshooting section for more information on when to use these kits

<u>Kit Part #</u>	<u>Description</u>
0504163	Inlet valve kit
0504164	Outlet valve kit
0501014	Saddle seat/seal kit

Parts List • Liste de Pièces • Lista de piezas

Sprayer • Pulvérisateur • Rociador

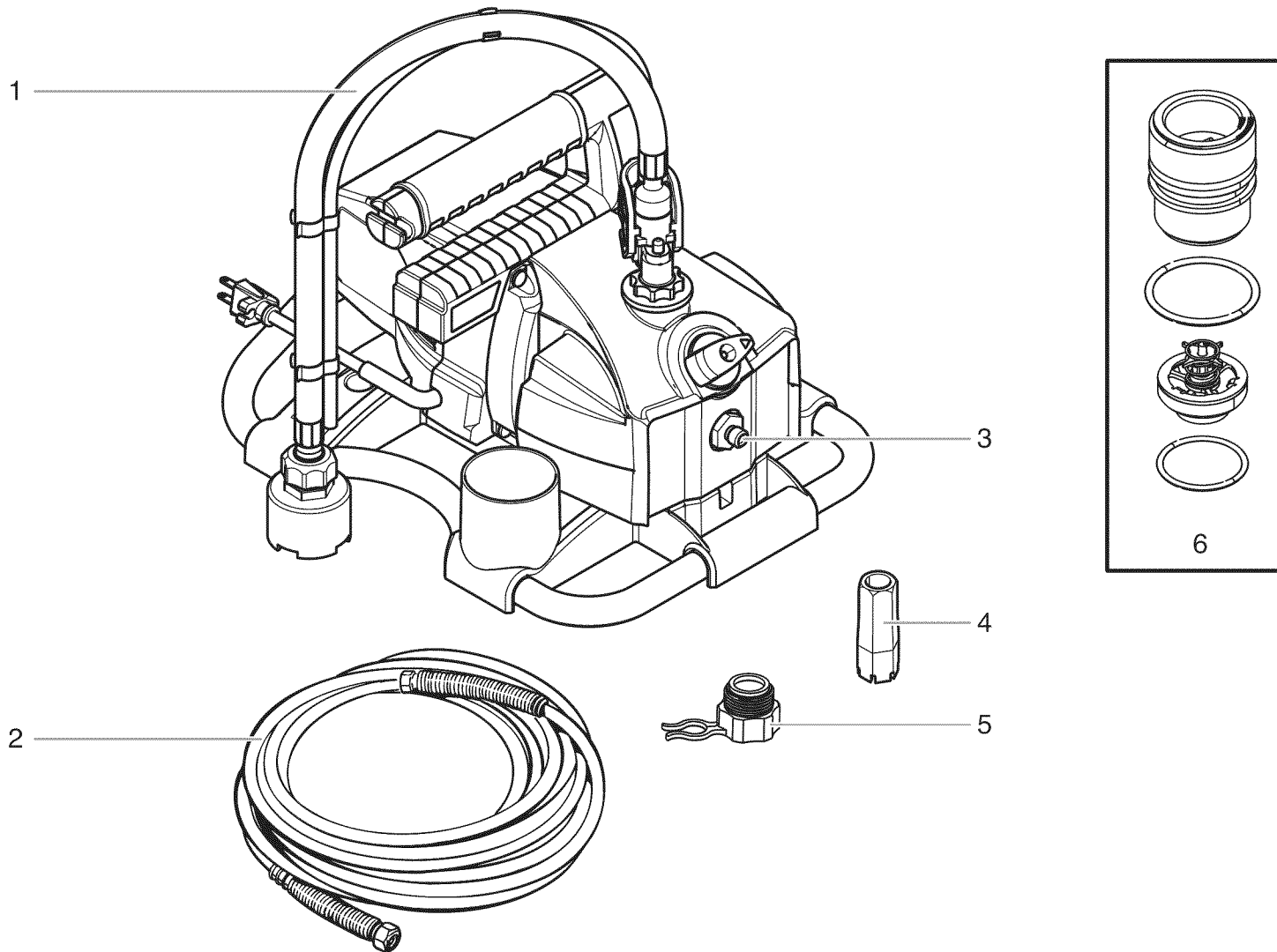

Item Article Artículo	Part No. No de pièce Pieza No.	English - Description	Français - Description	Español - Descripción	Quantity Quantite Cantidad
1	0504156	Suction set assembly	Ensemble de dispositif d'aspiration	Ensamblaje del juego de succión	1
2	0515454	Spray hose	Flexible de pulvérisation	Manguera de rociadora	1
3	0504164	Outlet valve	Soupape de sortie	Válvula de salida	1
4	0504220	Inlet valve tool	Outil de soupape d'entrée	Herramienta de válvula de entrada	1
5	0515146	Pump cleaning adapter	Adaptateur de nettoyage de pompe	Adaptador de limpieza de bomba	1
6	0504163	Inlet valve kit	Trousse de joint de soupape d'entrée	Juego de sellos para la válvula de entrada	1

Parts List • Liste de Pièces • Lista de piezas

Spray Gun • Pistolet • Pistola

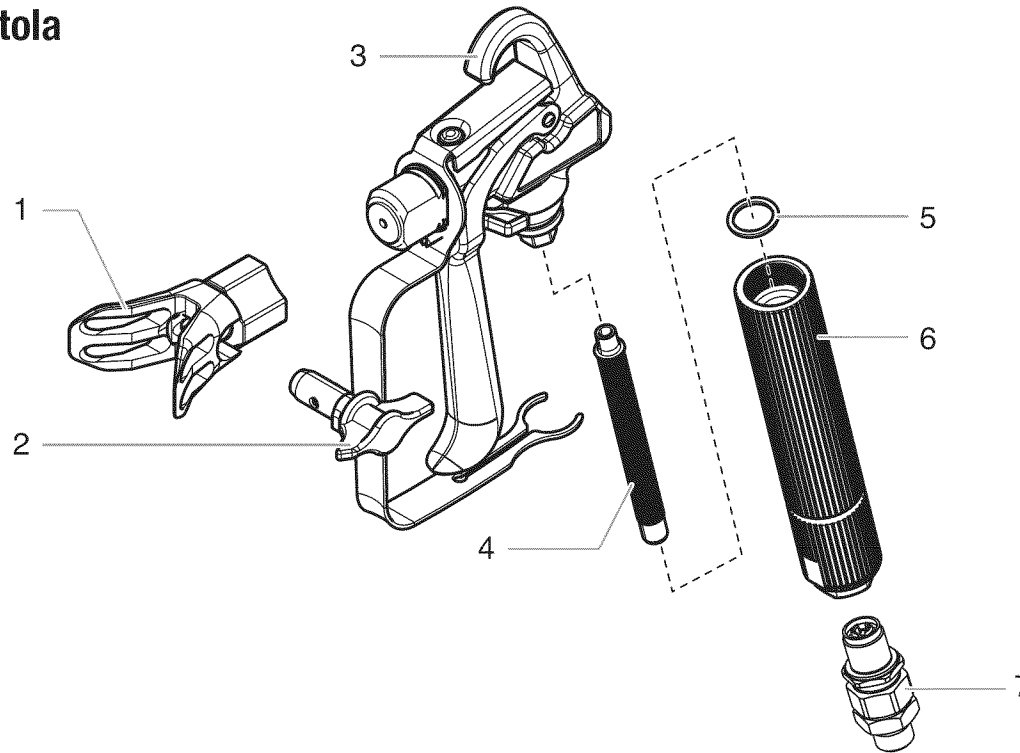

Item Article Artículo	Part No. No de pièce Pieza No.	English - Description	Français - Description	Español - Descripción	Quantity Quantite Cantidad
1	0501011	Guard assembly	Protège-embout	Ensamblaje de protección	1
2	0501515	Tip, 515	Buse, 515	Boquilla, 515	1
3	0515229	Complete gun assembly (Includes items 3-6)	Pistolet et ses composants (inclus les articles 3-6)	Ensamblaje de la pistola (incluye artículos 3-6)	1
4	0154675	Filter, 100 mesh (yellow, 2 pack)	Filtre, maille 100 (jaune, trousse de 2)	Filtro, malla 100 (amarillo, juego de 2)	1
5	0515228	Seal	Joint d'étanchéité	Sello	1
6	-----	Filter housing	Logement de filtre	Alojamiento de filtro	1
7	0347706A	Swivel	Raccord	Giratoria	1

Tip/Filter Accessories • Accessoires de buse/filtre • Accesorios de punta/filtro

English - All spray tips and filters listed below are sold separately.

Spray Tip		Spray Gun filters			Spray Material	Initial Pressure Setting
Part No.	Tip Size*	Part No.	Filter Type	Filter Color		
0501411	411	0154918	Extrafine	Red	Thin stains, sealers	Minimum
0501511	511					
0501413	413	0154675	Fine	Yellow	Thick latex paints, stains	Maximum
0501513	513					
0501415	415					
0501515	515					

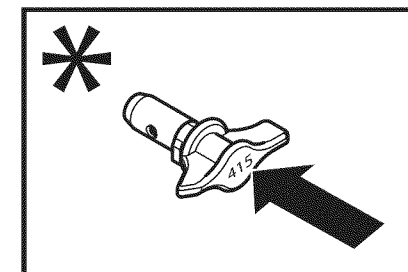

Français - Tous les buses de pulvérisation et de filtres ci-dessous sont vendues séparément.

Buse		Filtre			Matière liquide à pulvériser	Initial pression
No de pièce	Dimension*	No de pièce	Type de filtre	Couleur		
0501411	411	0154918	Extra-fin	Rouge	Matière liquide à pulvériser moins épaisse	Minimale
0501511	511					
0501413	413	0154675	Fin	Jaune	Matière liquide plus épaisse	Maximale
0501513	513					
0501415	415					
0501515	515					

Español - Todas las puntas y los filtros de rociado se enumeran a continuación se venden por separado.

Punta		Filtro			Materiales que se pulverizan	Configuración inicial de presión
Pieza No.	Tamaño*	Pieza No.	Tipo de filtro	Color		
0501411	411	0154918	Extrafino	Rojo	Materiales que se pulverizan de menor densidad	Mínima
0501511	511					
0501413	413	0154675	Fino	Amarillo	Materiales más densos	Máxima
0501513	513					
0501415	415					
0501515	515					

Limited Warranty

AIRLESS PAINT SPRAY EQUIPMENT

This product, manufactured by Wagner Spray Tech Corporation (Wagner), is warranted to the original retail purchaser against defects in material and workmanship for one year from date of purchase.

This warranty does not cover damage resulting from improper use, accidents, user's negligence or normal wear. This warranty does not cover any defects or damages caused by service or repair performed by anyone other than a Wagner Authorized Service Center. This warranty does not apply to accessories.

ANY IMPLIED WARRANTY OF MERCHANTABILITY OR FITNESS FOR A PARTICULAR PURPOSE IS LIMITED TO ONE YEAR FROM DATE OF PURCHASE. IF USED FOR COMMERCIAL OR RENTAL PURPOSES, THIS WARRANTY APPLIES ONLY FOR 30 DAYS FROM DATE OF PURCHASE.

WAGNER SHALL NOT IN ANY EVENT BE LIABLE FOR ANY INCIDENTAL OR CONSEQUENTIAL DAMAGES OF ANY KIND, WHETHER FROM BREACH OF THIS WARRANTY OR ANY OTHER REASON.

If any product is defective in material and/or workmanship during the applicable warranty period, return it with proof of purchase, transportation prepaid to any Wagner Authorized Service Center. (Service Center listing is enclosed with this product.) Wagner's Authorized Service Center will either repair or replace the product (at Wagner's option) and return it to you, postage prepaid.

SOME STATES DO NOT ALLOW LIMITATIONS ON HOW LONG AN IMPLIED WARRANTY LASTS OR THE EXCLUSION OF INCIDENTAL OR CONSEQUENTIAL DAMAGES, SO THE ABOVE LIMITATION AND EXCLUSION MAY NOT APPLY TO YOU.

THIS WARRANTY GIVES YOU SPECIFIC LEGAL RIGHTS, AND YOU MAY ALSO HAVE OTHER RIGHTS WHICH VARY FROM STATE TO STATE.

GARANTIE LIMITÉE

MATÉRIEL DE PULVÉRISATION DE PEINTURE SANS AIR

Ce produit, fabriqué par Wagner Spray Tech Corporation (Wagner), est garanti, au bénéfice de l'acheteur au détail d'origine, contre tout vice de matières et toute malfaçon pour un an à compter de la date d'achat.

La présente garantie ne s'applique pas aux dégâts entraînés par une utilisation incorrecte, par la négligence de l'utilisateur ou par l'usure normale. La présente garantie ne s'applique pas non plus aux défauts ou dommages résultant de l'entretien ou de la réparation que fait une personne quelconque qui ne soit pas membre d'un centre d'entretien autorisé pour les produits Wagner. La présente garantie ne s'applique pas aux accessoires.

TOUTE GARANTIE IMPLICITE DE VENDABILITÉ OU DE CONVENANCE À UNE DESTINATION PARTICULIÈRE EST LIMITÉE À UN AN À COMPTER DE LA DATE D'ACHAT. DANS LE CAS DE LOCATION OU AUTRES APPLICATIONS PROFESSIONNELLES, CETTE GARANTIE SE LIMITE À 30 JOURS À PARTIR DE LA DATE D'ACHAT.

WAGNER NE POURRA EN AUCUN CAS ÊTRE TENUE RESPONSABLE DE DOMMAGES-INTÉRÊTS INDIRECTS OU CONSÉCUTIFS, QUE CE SOIT POUR UNE RUPTURE DE CETTE GARANTIE OU TOUTE AUTRE RAISON.

Si un produit est défectueux en ce qui concerne les matériaux ou l'exécution pendant la période de garantie applicable, vous devez le retourner, avec une preuve d'achat et frais de port payés, à n'importe quel centre d'entretien autorisé pour les produits Wagner. (Une liste de ces centres d'entretien est jointe à ce produit.) Le centre d'entretien autorisé pour les produits Wagner réparera ou remplacera le produit (à la discrétion de Wagner) et vous le retournera par la poste, avec frais de port payés.

CERTAINES PROVINCES INTERDISENT LES RESTRICTIONS SUR LA DURÉE D'UNE GARANTIE IMPLICITE OU L'EXCLUSION DES DOMMAGES ACCESSOIRES OU INDIRECTS. IL SE PEUT DONC QUE LA RESTRICTION ET L'EXCLUSION ÉNONCÉES CI-DESSUS NE S'APPLIQUENT PAS À VOUS.

LE PRÉSENTE GARANTIE VOUS ACCORDE DES DROITS JURIDIQUES SPÉCIFIQUES, ET VOUS AVEZ PEUT-ÊTRE D'AUTRES DROITS, QUI PEUVENT VARIER D'UNE PROVINCE À L'AUTRE.

GARANTÍA LIMITADA

EQUIPO DE ATOMIZACIÓN DE PINTURA SIN AIRE

Este producto, fabricado por Wagner Spray Tech Corporation (Wagner), está garantizado ante el comprador original contra defectos de materiales y mano de obra durante un año contado a partir de la fecha de compra.

Esta garantía no cubre los daños que sean resultado de un uso inapropiado, accidentes, negligencia del usuario o un desgaste normal. Esta garantía no cubre ningún defecto o daño que haya sido causado por los servicios o reparaciones llevadas a cabo por alguien que no sea un técnico del Centro de Servicio Autorizado de Wagner. Esta garantía no es válida para ningún accesorio.

CUALQUIER GARANTIA IMPLICITA DE COMERCIALIZACION O IDONEIDAD PARA CUALQUIER PROPOSITO EN PARTICULAR QUEDA LIMITADA A UN AÑO A PARTIR DE LA FECHA DE COMPRA. SI SE LE DA USO PROFESIONAL Y DE RENTA, ESTA GARANTÍA TIENE UNA DURACIÓN DE 30 DÍAS A PARTIR DE LA FECHA DE COMPRA.

WAGNER NO SERÁ EN NINGÚN CASO RESPONSABLE DE NINGÚN DAÑO INCIDENTAL O DE CONSECUENCIA DE NINGUNA CLASE, QUE RESULTE DE VIOLAR ESTA GARANTÍA O POR CUALQUIER OTRA RAZÓN.

Si algún producto llegara a tener defectos de material y/o mano de obra durante el período de validez de la garantía, devuélvalo junto con el comprobante de compra y flete previamente pagado, a cualquier Centro de Servicio Autorizado de Wagner. (La lista de Centros de Servicio viene adjunta con este producto.) El Centro de Servicio Autorizado de Wagner reparará o reemplazará el producto (según la opción de Wagner) y se lo devolverá, con porte previamente pagado.

ALGUNOS ESTADOS NO PERMITEN LIMITACIONES EN CUANTO A LA DURACIÓN DE UNA GARANTÍA IMPLÍCITA O LA EXCLUSIÓN DE DAÑOS INCIDENTALES O DE CONSECUENCIA, DE MANERA QUE LA LIMITACIÓN Y EXCLUSIÓN ANTERIORES PODRÍAN NO SER VÁLIDAS PARA USTED.

ESTA GARANTÍA LE CONCEDE DERECHOS LEGALES ESPECÍFICOS, PERO USTED PODRÍA TENER DERECHO A OTROS, LOS CUALES VARIAN DE UN ESTADO A OTRO.