

STEELE[®]
products

Owner's Manual

1000 Watt Generator 2 Stroke



WARNING! To Reduce The Risk Of Injury, User Must Read And Understand Instruction Manual.

SP-GG100

FOR SERVICE CALL: 888-896-6881
PARA SERVICIO LLAME: 888-896-6881

www.steele-products.com

1000 WATT GENERATOR

Table of Contents

Topic	Page
Table of Contents	2
Safety Information	3
Specifications	4
Components	5
Starting Your Generator	6
Operating Your Generator	6
Stopping Your Generator	6
Maintenance	6
Storage	7
Statement	7
Trouble Shooting	8
Generator Theory Diagram	9
Limited Warranty	10
Parts List	12

1000 WATT GENERATOR

Safety Information



CAUTION

PLEASE READ AND UNDERSTAND THIS MANUAL COMPLETELY, BEFORE OPERATING THIS GENERATOR.

Never operate the engine in an enclosed area. All gasoline engines produce carbon monoxide gas while running. Breathing exhaust fumes can kill. Operate the engine in a well-ventilated area, only.

Extract from CPSC Document #5008 on Carbon Monoxide

The U.S. Consumer Product Safety Commission (CPSC) has issued the following warning regarding carbon monoxide poisoning:

- Do not use portable heaters or lanterns while sleeping in enclosed areas such as tents, campers, and other vehicles. This is especially important at high altitudes, where the risk of carbon monoxide poisoning is increased.
- Know the symptoms of carbon monoxide poisoning: headache, dizziness, weakness, nausea, vomiting, sleepiness, and confusion. Carbon monoxide reduces the blood's ability to carry oxygen. Low blood oxygen levels can result in loss of consciousness and death.
- See a doctor if you or a member of your family develops cold or flu like symptoms. Carbon monoxide poisoning can easily be mistaken for a cold or flu, and is often detected too late.
- Alcohol consumption and drug use increase the effects of carbon monoxide poisoning.
- Carbon monoxide is especially toxic to mother and child during pregnancy, infants the elderly, smokers, and people with blood or circulatory system problems, such as anemia, or heart disease.

Fuel Is Highly Flammable

DO NOT refuel while engine is running.

DO NOT refuel near sparks or open flame.

DO NOT smoke while refueling.

ALWAYS allow the engine and muffler to cool before refueling.

Refuel ONLY in well-ventilated area.

DO NOT over-fill gas tank

Engine And Muffler Get Very Hot

Keep flammable materials at least 3 feet from generator.

When in use, place generator in an area where children are not likely to touch it.

Electric Shock Hazard

DO NOT operate in rain or snow, or next to body of water.

DO NOT touch with wet hands.

Be sure to USE GROUNDED PLUGS with the generator.

DO NOT connect generator to commercial power outlets.

1000 WATT GENERATOR

Specifications

DIMENSIONS	
Length	15 in.
Width	12 in.
Height	14 in.
Weight	44.1 lbs.

ENGINE	
Type	Air cooled 2-stroke
Fuel	Nonleaded gasoline with a minimum of 90% octane
Oil	Two-stroke lubrication
Gasoline and oil mixing ratio	50 : 1
Displacement	63 cc
Starting System	Recoil (Electronic Ignition)
Driving System	Direct Coupling, Taper Fit
Spark Plug	BSES
Governor	Mechanical(Adjustable)
Cooling System	Forced Air
Stroke	TWO Stroke
Carburetor Type	Hg63
Air Cleaner Type	Sponge element
Compression Rate	6
Decibel Ratio	80db @ 3.3 ft 65db @ 24 ft.
Rated Output	1.5 HP @ 3600 rpm
Fuel Tank Capacity	1.2 Gal.

GENERATOR	
AC Output Rating	120Volts
Frequency	60 Hz
AC Current	6.7 Amps
Rated Output, Continuous	800 Watts
DC Output Rating	12 Volts
DC Current	10 Amps
Power Factor	$\text{COS}\phi = 1$
Steady State Voltage range	+/- 15%
Steady State Frequency range	Less than 7%
Voltage Waveform Twist Rate	Less than 25%

1000 WATT GENERATOR

Generator Components

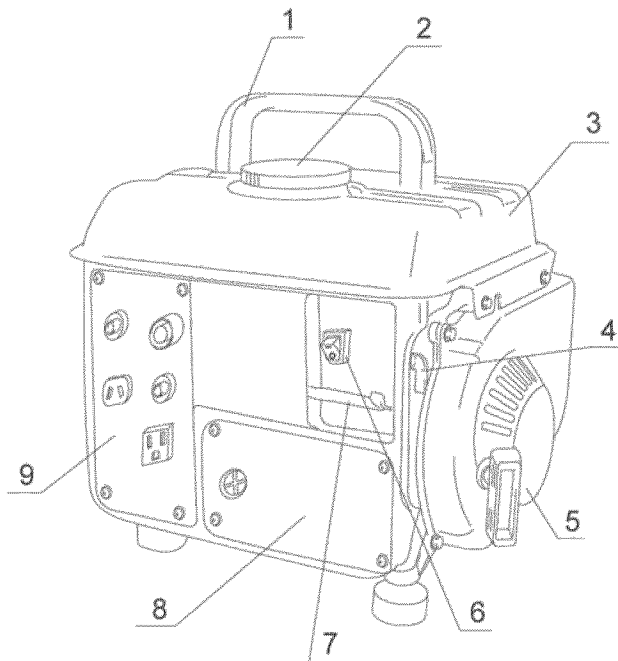

- 1. Handle
- 2. Fuel Cap
- 3. Fuel Tank
- 4. Fuel Shut-off
- 5. Recoil Starter
- 6. Engine On-Off Switch
- 7. Throttle Lever
- 8. Air Cleaner
- 9. Control Panel

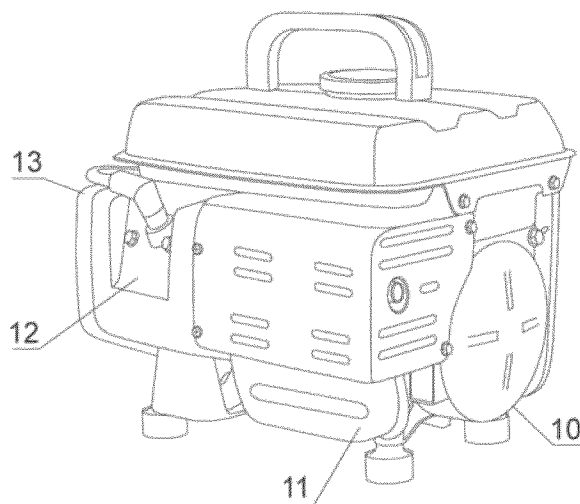

- 10. Generator
- 11. Muffler
- 12. Cylinder
- 13. Spark Plug

1000 WATT GENERATOR

STARTING THE ENGINE

1. Disconnect all electric appliances from generator before starting.
2. Turn fuel shut-off lever to "ON".
3. Move Choke lever all the way to the left.
4. Turn engine switch to "ON" position.
5. Pull recoil starter cord slowly until engaged, then pull briskly to start.
6. Once engine has started, move choke lever all the way back to the right.

CONNECTING ELECTRICAL APPLIANCES

Always allow engine to warm up before connecting any electrical load to the generator.

STOPPING ENGINE

1. Turn off all appliances, then disconnect them from the generator.
2. Turn engine Switch to "STOP" position.
3. Turn fuel shut-off lever to "OFF"
4. Allow engine to cool before attempting to move the generator or to refuel.

RESETTING BREAKER BUTTONS

If reset trips, disconnect all external electrical appliances before pushing the reset button. After reconnecting the external electrical appliance, if reset continues to trip that indicates that the electrical lead connected to the generator from one or more of the appliances may have a short circuit. In that event, discontinue use of that item until it has been checked and/or repaired by a qualified technician.

PERIODIC MAINTENANCE

Service intervals

Clean air filter after every 150 hours of run time. (If used in very dusty conditions, clean air filter after every 10 hours of run time)

1. Remove foam filter and wash in mild detergent or dish washing liquid.
2. Rinse thoroughly, than squeeze out excess water.
3. Allow to thoroughly dry at room temperature.
4. Pour a small amount of gasoline in filter element, then squeeze out any excess gasoline.
5. Replace filter.

Clean spark plug every 50 hours of run time.

1. Remove spark plug and clean electrode with wire brush.
2. Reset gap to .028- .031 in. (.7-.8mm)

1000 WATT GENERATOR

Clean fuel filter every 150 hours of run time.

1. Remove fuel filter from inside fuel tank.
2. Clean with solvent.
3. Wipe dry.
4. Insert filter back in fuel tank.

STORAGE

If the generator will not be used for more than one month, follow the following procedures:

1. Drain all fuel from engine (including fuel tank, fuel cock, and carburetor).
2. Shake tank and drain excess oil.
3. Remove spark plug and pour approximately one (1) tablespoon of motor oil into spark plug hole.
4. Replace spark plug.
5. With ignition switch in "OFF" position, pull starter cord several times until you feel piston is in its compression stroke. (resistance will increase).
6. Cover generator and store in dry, well-ventilated, place.

STATEMENT

1. For non-handheld engines: The Emissions Compliance Period referred to on the Emissions Compliance label indicates the number of operating hours for which the engine has been shown to meet Federal emission requirements. For engines less than 66 cc, Category C=50 hours, B=125 hours, and A=300 hours. For engines equal to or greater than 66 cc but less than 225 cc displacement, Category C=125 hours, B=250 hours, and A=500 hours. For engines of 225 cc or more, Category C=250 hours, B=500 hours, and A=1000 hours.
2. For handheld engines: The Emissions Compliance Period referred to on the Emissions Compliance label indicates the number of operating hours for which the engine has been shown to meet Federal emission requirements. Category C=50 hours, B=125 hours, and A=300 hours.

GENERATOR SET TROUBLE SHOOTING

1000 WATT GENERATOR

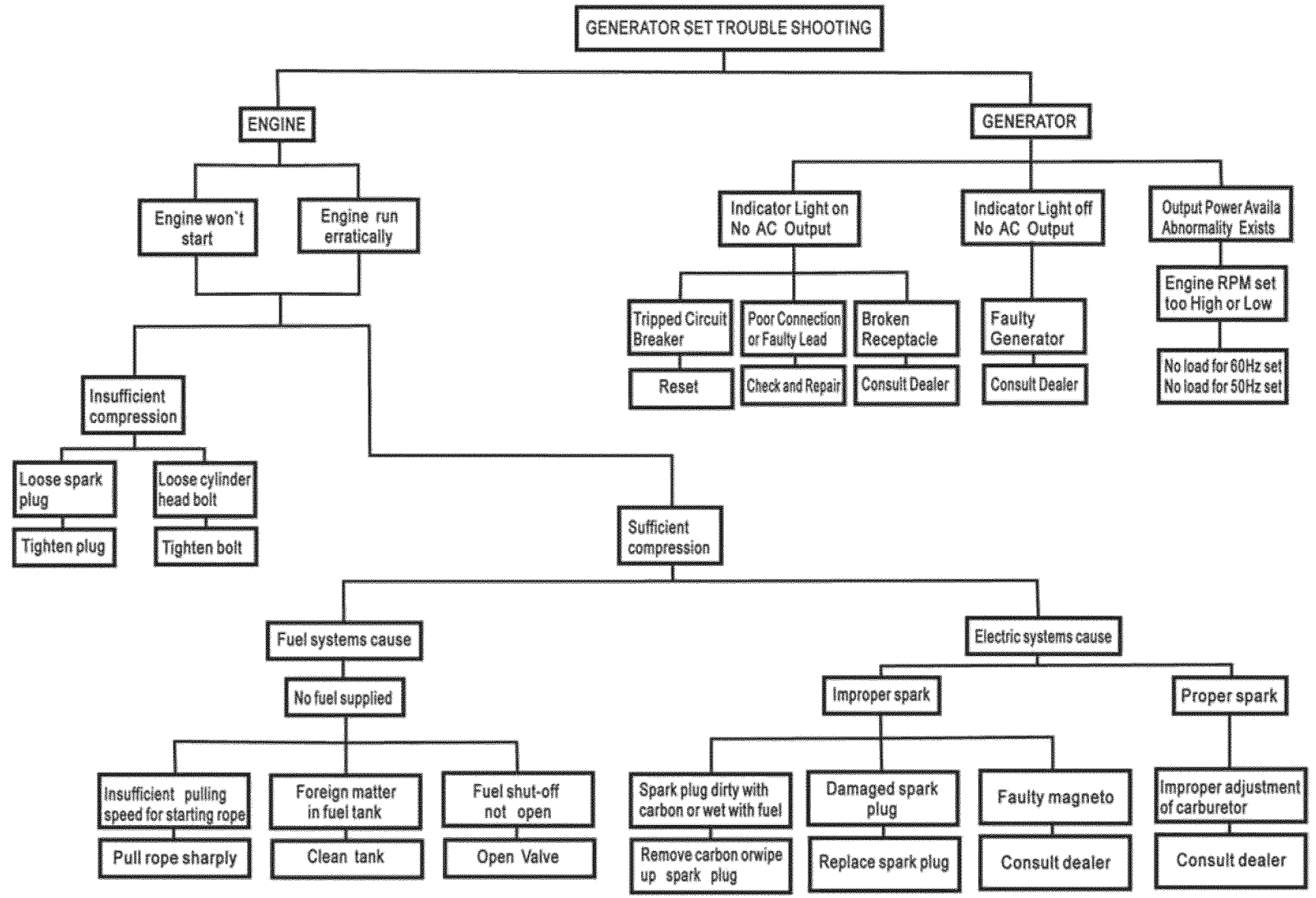

1000 WATT GENERATOR

GENERATOR THEORY DIAGRAM

Rotor

Stator

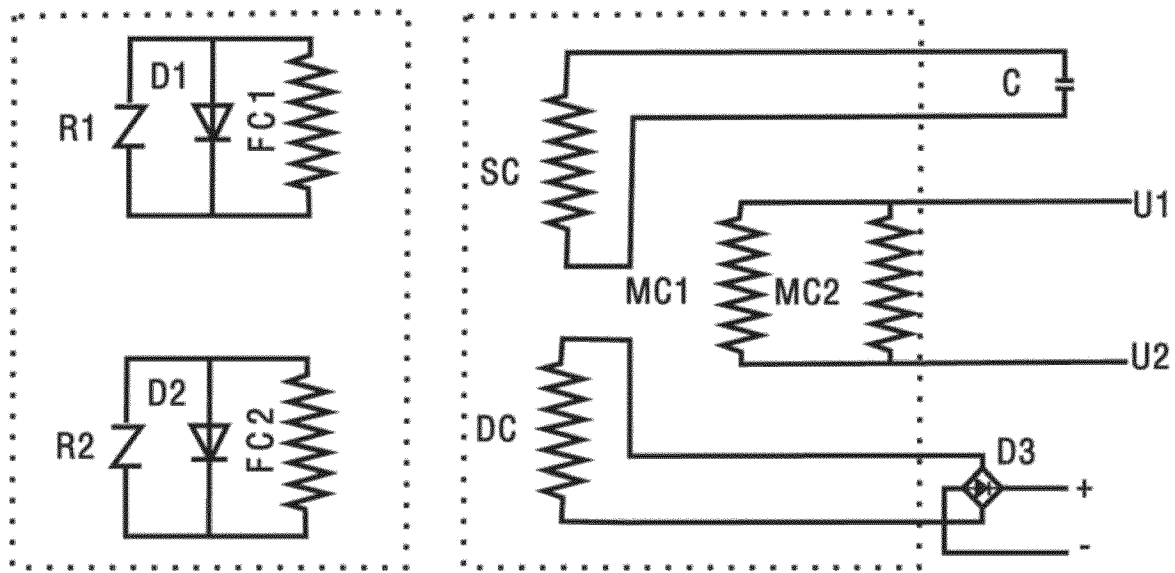

R1 > Over Volt Protective
R2 > Resistance

D1 > Spin Rectifier
D2 > Spin Rectifier

FC1 > Rotor Pole Winding
FC2 > Rotor Pole Winding

SC < Stator Auxiliary Winding

DC < Stator DC Winding

MC1 > Stator Main Winding
MC2 > Stator Main Winding

C < Capacitor

D3 < Single-phase Rectifier

1000 WATT GENERATOR

Limited Warranty

STEELE® warrants to the original purchaser who uses the product in a consumer application (personal, residential or household usage) that all products covered under this Warranty are free from defects in material and workmanship for one year from the date of purchase. All products covered by this limited Warranty which are used in commercial applications (i.e. income producing) are warranted to be free of defects in material and workmanship for 90 days from the date of original purchase. Products covered under this Warranty include air compressors, air tools, service parts, pressure washers and generators.

STEELE® will repair or replace at STEELE®'s sole option, products or components which have failed within the warranty period. Service will be scheduled according to the normal work flow and business hours at the service center location, and the availability of replacement parts. All decisions of STEELE® with regard to this limited warranty shall be final.

This warranty gives you specific legal rights, and you may also have other rights which vary from state to state.

RESPONSIBILITY OF ORIGINAL PURCHASER (initial User):

- To process a warranty claim on this product, DO NOT return item to the retailer. The product must be evaluated by an Authorized Warranty Service Center. For the location of the nearest Authorized Warranty Service Center contact the retailer or place of purchase.
- Retain original cash register sales receipt as proof of purchase for warranty work.
- Use reasonable care in the operation and maintenance of the product as described in the Owner's Manual(s).
- Deliver or ship the product to the nearest Authorized Warranty Service Center. Freight costs, if any, must be paid by the purchaser.
- Air compressors with 60 and 80 gallon tanks will be inspected at the site of installation. Contact the nearest Authorized Warranty Service Center that provides on-site service calls for service call arrangements.
- If the purchaser does not receive satisfactory results from the Authorized Warranty Service Center, the purchaser should contact STEELE®.

1000 WATT GENERATOR

Limited Warranty (cont'd)

THIS WARRANTY DOES NOT COVER:

- Merchandise sold as reconditioned, used as rental equipment, or floor or display models.
- Merchandise that has become damaged or inoperative because of ordinary wear, misuse, cold, heat, rain, excessive humidity, freeze damage, use of improper chemicals, negligence, accident, failure to operate the product in accordance with the instructions provided in the Owner's Manual(s) supplied with the product, improper maintenance, the use of accessories or attachments not recommended by STEELE®, or unauthorized repair or alterations.
- Repair and transportation costs of merchandise determined not to be defective.
- Costs associated with assembly, required oil, adjustments or other installation and start-up costs.
- Expendable parts or accessories supplied with the product which are expected to become inoperative or unusable after a reasonable period of use.
- Merchandise sold by STEELE® which has been manufactured by and identified as the product of another company, such as gasoline engines. The product manufacturer's Warranty, if any, will apply.
- ANY INCIDENTAL, INDIRECT OR CONSEQUENTIAL LOSS, DAMAGE, OR EXPENSE THAT MAY RESULT FROM ANY DEFECTS, FAILURE OR MALFUNCTION OF THE PRODUCT IS NOT COVERED BY THIS WARRANTY. Some states do not allow the exclusion, so it may not apply to you.
- IMPLIED WARRANTIES, INCLUDING THOSE OF MERCHANTABILITY OR FITNESS FOR A PARTICULAR PURPOSE, ARE LIMITED TO ONE YEAR FROM THE DATE OF ORIGINAL PURCHASE. Some states do not allow limitations on how long an implied warranty lasts, so the above limitations may not apply to you.

www.steele-products.com

16273 E. Gale Ave
City Of Industry, CA 91745
all rights reserved

1000 WATT GENERATOR

Parts List



1000W Generator

Cylinder head system assy.

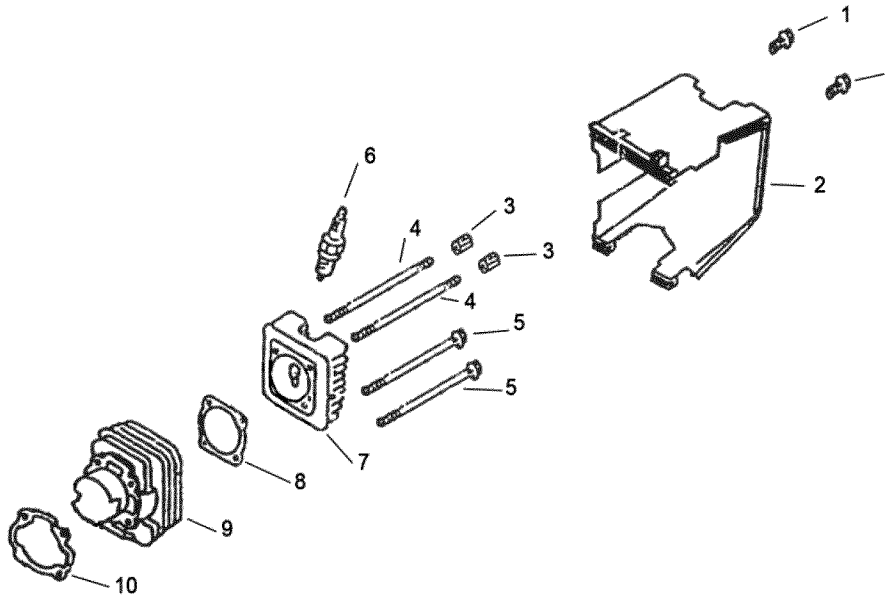

APG Part No.	Description	Part. No
SP-GG100-A-01	FLANGE BOLT(M6×12)	GE1E45F-A-01
SP-GG100-A-02	CYLINDER AIR SHROUD	GE1E45F-A-02
SP-GG100-A-03	NUT(M6x18)	GE1E45F-A-03
SP-GG100-A-04	STUD BOLT(M6x113)	GE1E45F-A-04
SP-GG100-A-05	FLANGE BOLT(M6×100)	GE1E45F-A-05
SP-GG100-A-06	SPARK PLUG	GE1E45F-A-06
SP-GG100-A-07	CYLINDER HEAD	GE1E45F-A-07
SP-GG100-A-08	CYLINDER HEAD GASKET	GE1E45F-A-08
SP-GG100-A-09	CYLINDER LINER	GE1E45F-A-09
SP-GG100-A-10	CYLINDER BOTTOM GASKET	GE1E45F-A-10

1000W Generator

Cylinder barrel

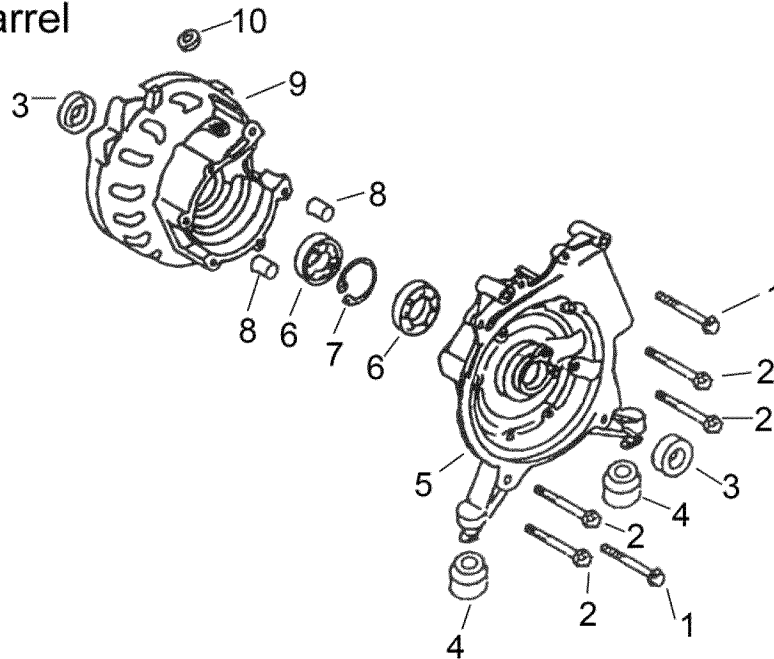

B

APG Part No.	Description	Part. No
SP-GG100-A-01	FLANGE BOLT(M6×55)	GE1E45F-B-01
SP-GG100-A-02	FLANGE BOLT(M6×50)	GE1E45F-B-02
SP-GG100-A-03	OIL SEAL(φ 30× φ 20×7)	GE1E45F-B-03
SP-GG100-A-04	RUBBER PAD	GE1E45F-B-04
SP-GG100-A-05	CRANKCASE(LEFT)	GE1E45F-B-05
SP-GG100-A-06	BEARING(6004)	GE1E45F-B-06
SP-GG100-A-07	SPEED REGULATION FORK(φ 47)	GE1E45F-B-07
SP-GG100-A-08	LOCATING RING(φ 10)	GE1E45F-B-08
SP-GG100-A-09	CRANKCASE(RIGHT)	GE1E45F-B-09
SP-GG100-A-10	OIL SEAL(φ 12× φ 6×5)	GE1E45F-B-10

1000W Generator

Piston and crankshaft connecting rod system assy.

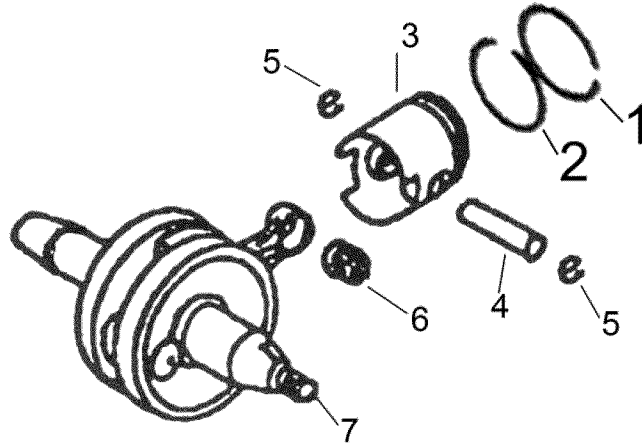

C

APG Part No.	Description	Part. No
SP-GG100-C-01	COMPRESSION RING A	GE1E45F-C-01
SP-GG100-C-02	COMPRESSION RING B	GE1E45F-C-02
SP-GG100-C-03	PISTON	GE1E45F-C-03
SP-GG100-C-04	PISTON PIN	GE1E45F-C-04
SP-GG100-C-05	PISTON PIN CLIP(10mm)	GE1E45F-C-05
SP-GG100-C-06	NEEDLE BEARING($\phi 14 \times \phi 10 \times 13$)	GE1E45F-C-06
SP-GG100-C-07	CRANKSHAFT	GE1E45F-C-07

1000W Generator

Recoil starter system assy.

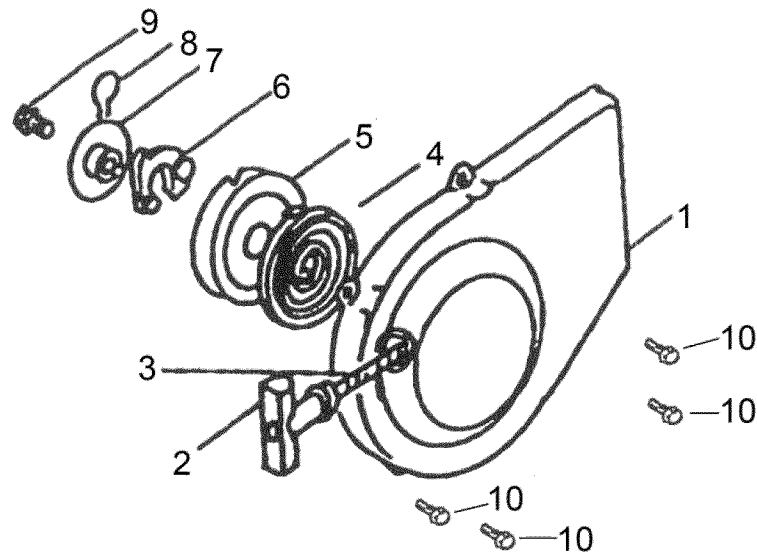

D

APG Part No.	Description	Part. No
SP-GG100-D-01	STARTING COVER	GE1E45F-D-01
SP-GG100-D-02	STARTER KNOB	GE1E45F-D-02
SP-GG100-D-03	RECOIL STARTER ROPE	GE1E45F-D-03
SP-GG100-D-04	START RETURN SPRING	GE1E45F-D-04
SP-GG100-D-05	RECOIL STARTER REEL	GE1E45F-D-05
SP-GG100-D-06	BEARING PLATE	GE1E45F-D-06
SP-GG100-D-07	DRIVE PLATE	GE1E45F-D-07
SP-GG100-D-08	CLIP SPRING	GE1E45F-D-08
SP-GG100-D-09	SETTING SCREW	GE1E45F-D-09
SP-GG100-D-10	FLANGE BOLT(M6×12)	GE1E45F-A-01

1000W Generator

Carburetor system assy.

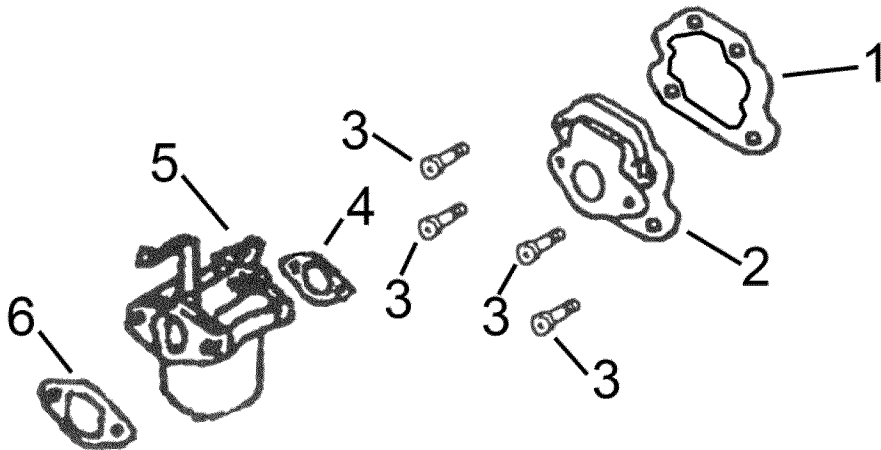

E

APG Part No.	Description	Part. No
SP-GG100-E-01	AIR INLET VALVE BODY GASKET	GE1E45F-E-01
SP-GG100-E-02	AIR INLET VALVE BODY	GE1E45F-E-02
SP-GG100-E-03	FLANGE BOLT(M6×20)	GE1E45F-E-03
SP-GG100-E-04	CARBURETOR GASKET (IN)	GE1E45F-E-04
SP-GG100-E-05	CARBURETOR ASSY	GE1E45F-E-05
SP-GG100-E-06	CARBURETOR GASKET (OUT)	GE1E45F-E-06

1000W Generator

Flywheel system assy.

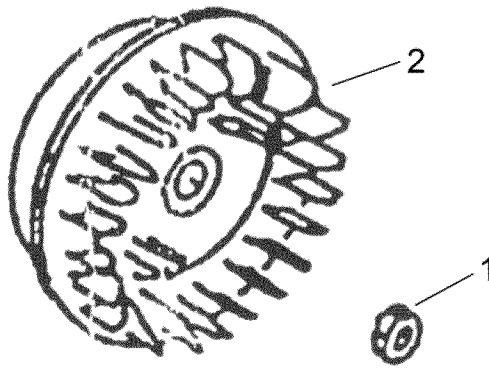

F

APG Part No.	Description	Part. No
SP-GG100-F-01	FLANGE NUT(M10×1.25)	GE1E45F-F-01
SP-GG100-F-02	FLYWHEEL	GE1E45F-F-02

1000W Generator

Ignition system assy.

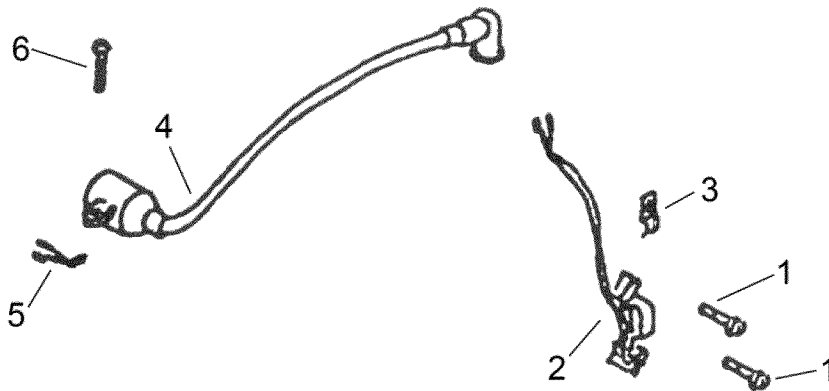

G

APG Part No.	Description	Part. No
SP-GG100-G-01	FLANGE BOLT(M6×20)	GE1E45F-E-03
SP-GG100-G-02	MAGNETO	GE1E45F-G-01
SP-GG100-G-03	LOCATING SHEET	GE1E45F-G-02
SP-GG100-G-04	HIGH VOLTAGE SET	GE1E45F-G-03
SP-GG100-G-05	STOP SWITCH CORD	GE1E45F-G-04
SP-GG100-G-06	FLANGE BOLT(M6×12)	GE1E45F-A-01

1000W Generator

Control system assy.

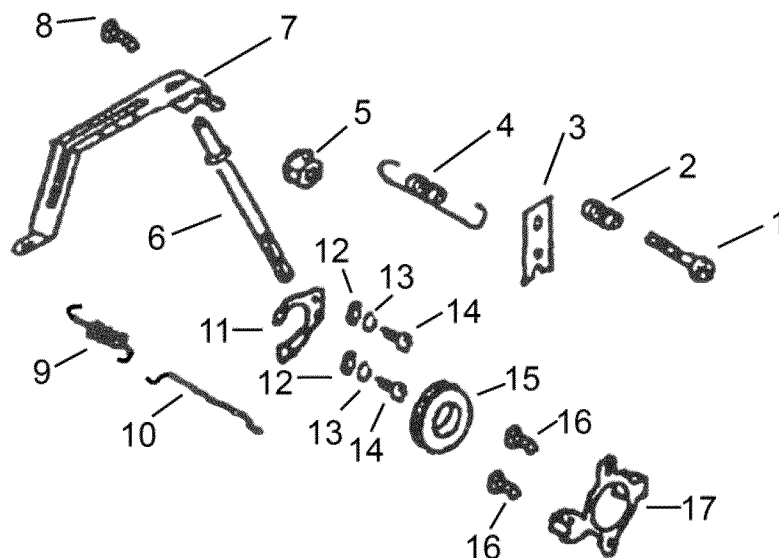

H

APG Part No.	Description	Part. No
SP-GG100-H-01	FLAT SCREW(M6×40)	GE1E45F-H-01
SP-GG100-H-02	CONTROL ADJUSTING SPRING	GE1E45F-H-02
SP-GG100-H-03	SPEED GOVERNING GASKET	GE1E45F-H-03
SP-GG100-H-04	SPEED GOVERNING SPRING	GE1E45F-H-04
SP-GG100-H-05	FLANGE NUT(M6)	GE1E45F-H-05
SP-GG100-H-06	SHIFT FET	GE1E45F-H-06
SP-GG100-H-07	GOVERNOR ARM	GE1E45F-H-07
SP-GG100-H-08	BOLT(M6×20)	GE1E45F-H-08
SP-GG100-H-09	THROTTLE RETURN SPRING	GE1E45F-H-09
SP-GG100-H-10	GOVERNOR ROD	GE1E45F-H-10
SP-GG100-H-11	SPEED REGULATION FORK	GE1E45F-H-11
SP-GG100-H-12	WASHER(φ3)	GE1E45F-H-12
SP-GG100-H-13	SPRING WASHER(φ3)	GE1E45F-H-13
SP-GG100-H-14	FLAT SCREW(M3×8)	GE1E45F-H-14
SP-GG100-H-15	SLIP RING	GE1E45F-H-15
SP-GG100-H-16	FLANGE BOLT(M6×8)	GE1E45F-H-16
SP-GG100-H-17	STAND	GE1E45F-H-17

1000W Generator

Muffler system assy.

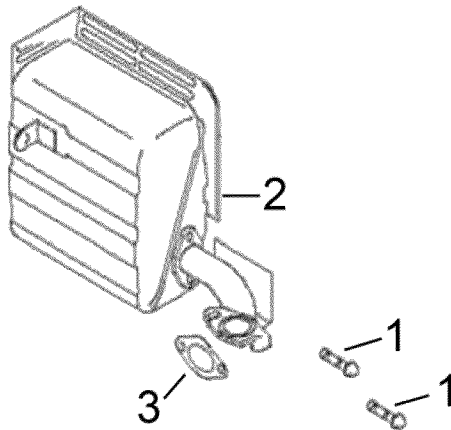

APG Part No.	Description	Part. No
SP-GG100-I-01	FLANGE BOLT(M6×20)	GE1E45F-E-03
SP-GG100-I-02	MUFFLER COMP.	GE1E45F-I-01
SP-GG100-I-03	MUFFLER GASKET	GE1E45F-I-02

1000W Generator

Fuel tank system assy.

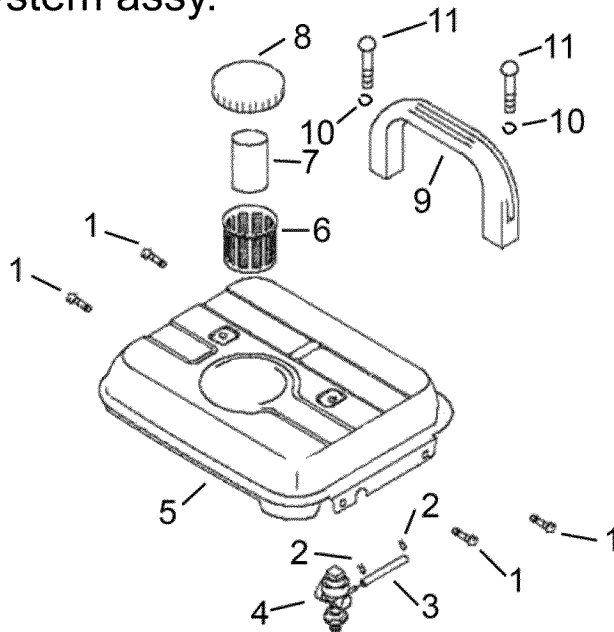

J

APG Part No.	Description	Part. No
SP-GG100-J-01	FLANGE BOLT(M6×12)	GE1E45F-A-01
SP-GG100-J-02	CLAMP	GE1E45F-J-01
SP-GG100-J-03	FUEL TUBE	GE1E45F-J-02
SP-GG100-J-04	FUEL CONTROL VALVE	GE1E45F-J-03
SP-GG100-J-05	FUEL TANK	GE1E45F-J-04
SP-GG100-J-06	FUEL FILTER	GE1E45F-J-05
SP-GG100-J-07	FUEL CUP	GE1E45F-J-06
SP-GG100-J-08	FUEL CAP	GE1E45F-J-07
SP-GG100-J-09	HANDLE	GE1E45F-J-08
SP-GG100-J-10	SPRING WASHER(φ6)	GE1E45F-J-09
SP-GG100-J-11	FLAT SCREW(M6×30)	GE1E45F-J-10

1000W Generator

Control box assy.

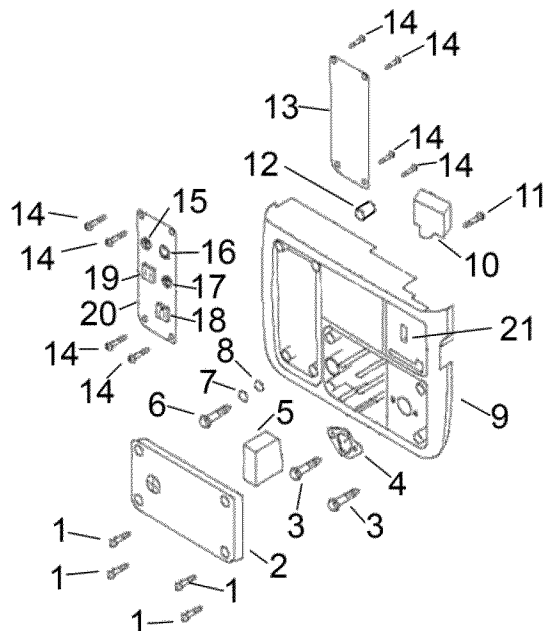

K

APG Part No.	Description	Part. No
SP-GG100-K-01	FLAT SCREW(M5×16)	GE1E45F-K-01
SP-GG100-K-02	AIR FILTER COVER	GE1E45F-K-02
SP-GG100-K-03	FLANGE BOLT(M6×65)	GE1E45F-K-03
SP-GG100-K-04	PLATE PAD	GE1E45F-K-04
SP-GG100-K-05	AIR FILTER	GE1E45F-K-05
SP-GG100-K-06	FLAT SCREW(M6×40)	GE1E45F-K-06
SP-GG100-K-07	SPRING WASHER(φ6)	GE1E45F-J-09
SP-GG100-K-08	WASHER(φ6)	GE1E45F-K-07
SP-GG100-K-09	CONTROL PANEL	GE1E45F-K-08
SP-GG100-K-10	CAPACITOR	GE1E45F-K-09
SP-GG100-K-11	PLATE SCREW(ST4.2×16)	GE1E45F-K-10
SP-GG100-K-12	TUBE(φ6)	GE1E45F-K-11
SP-GG100-K-13	PLATE COVER	GE1E45F-K-12
SP-GG100-K-14	PLATE SCREW(ST3.5×8)	GE1E45F-K-13
SP-GG100-K-15	DC CIRCUIT BREAKER(10A)	GE1E45F-K-14
SP-GG100-K-16	LIGHT	GE1E45F-K-15
SP-GG100-K-17	AC CIRCUIT BREAKER(8A)	GE1E45F-K-16

1000W Generator

Control box assy.

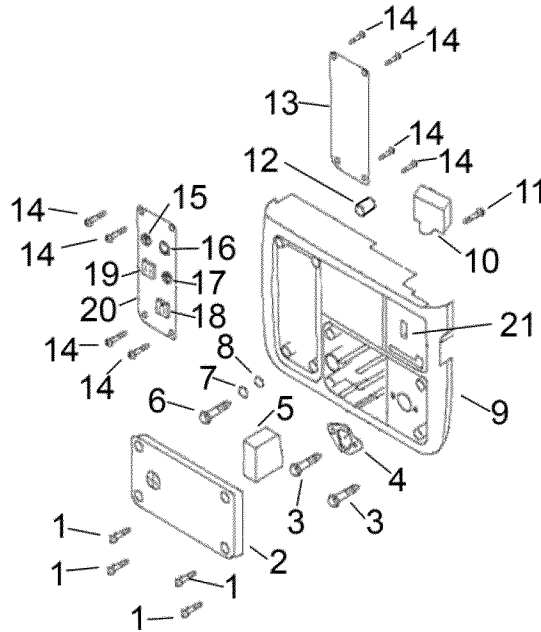

K

APG Part No.	Description	Part. No
SP-GG100-K-18	AC SOCKET	GE1E45F-K-17
SP-GG100-K-19	DC SOCKET	GE1E45F-K-18
SP-GG100-K-20	PANEL COVER	GE1E45F-K-19
SP-GG100-K-21	ENGINE SWITCH	GE1E45F-K-20

1000W Generator

Generator

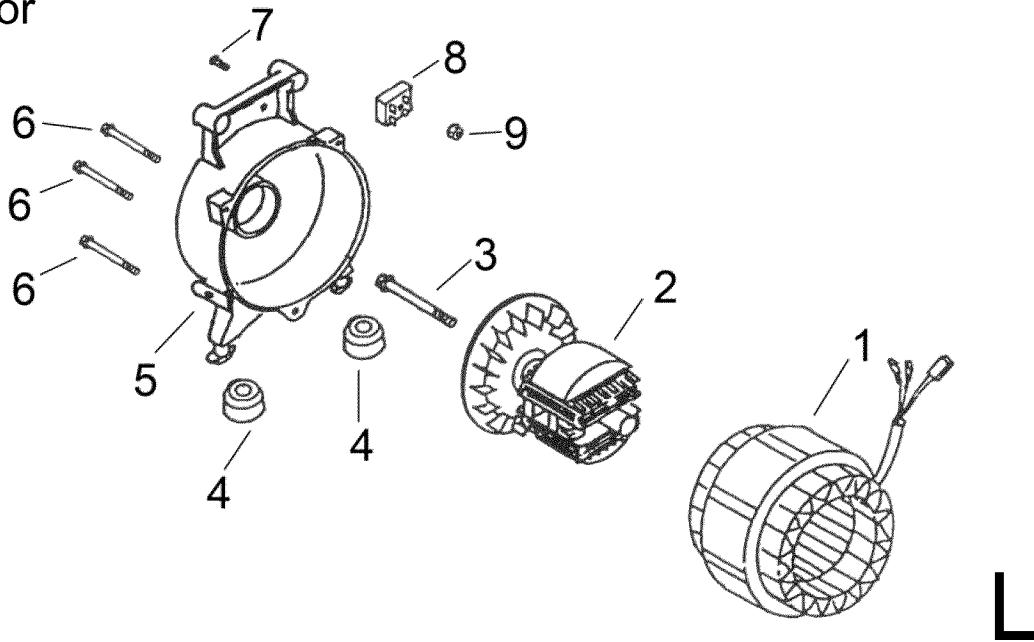

APG Part No.	Description	Part. No
SP-GG100-L-01	STATOR ASSY.	GE1E45F-L-01
SP-GG100-L-02	ROTOR COMP.	GE1E45F-L-02
SP-GG100-L-03	FLANGE BOLT(M8×155)	GE1E45F-L-03
SP-GG100-L-04	RUBBER PAD	GE1E45F-B-04
SP-GG100-L-05	GENERATOR STAY	GE1E45F-L-04
SP-GG100-L-06	FLANGE BOLT(M6×80)	GE1E45F-L-05
SP-GG100-L-07	FLAT SCREW(M4×20)	GE1E45F-L-06
SP-GG100-L-08	RECTIFIER COMP.	GE1E45F-L-07
SP-GG100-L-09	NUT(M4)	GE1E45F-L-08