

2340359003

Operator's Manual

CRAFTSMAN®

PROFESSIONAL

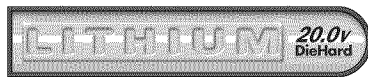

20.0-VOLT LITHIUM-ION CORDLESS 1/2-in. Hammer Drill/Driver

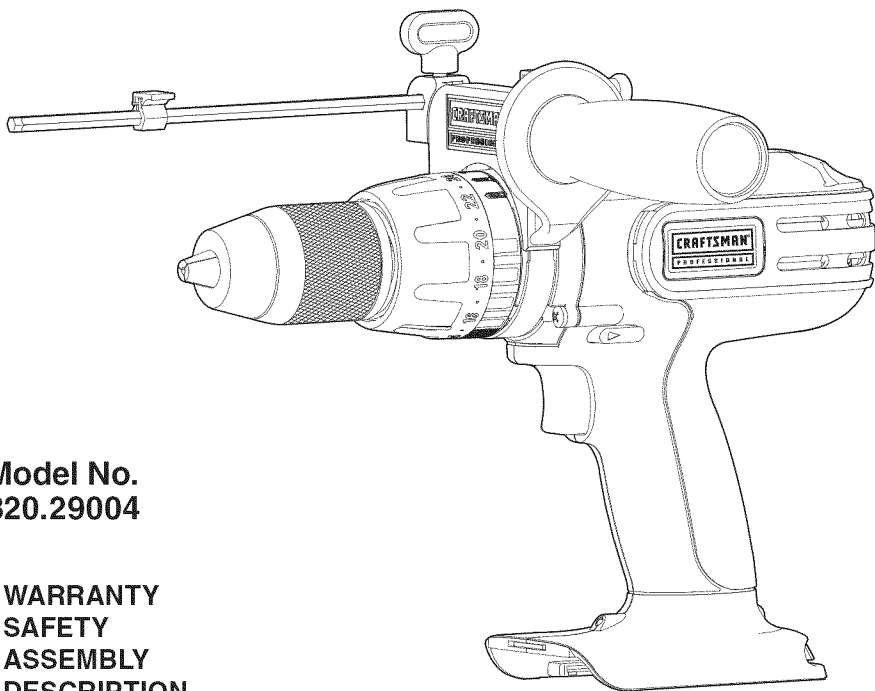

**Model No.
320.29004**

- **WARRANTY**
- **SAFETY**
- **ASSEMBLY**
- **DESCRIPTION**
- **OPERATION**
- **MAINTENANCE**

⚠ WARNING: To reduce the risk of injury, the user must read and understand the operator's manual before using this product.

**CHARGE BATTERY
BEFORE FIRST USE**

Sears Brands Management Corporation
Visit the Craftsman web page: www.sears.com/craftsman



Save this manual for future reference

2340359003

TABLE OF CONTENTS

■ Warranty	2
■ Introduction	2
■ Safety Symbols	3-4
■ General Safety Rules	5-7
■ Specific Safety Rules	7
■ Safety Rules for Charger	8-9
■ Description	10-11
■ Assembly	11
■ Operation	12-22
■ Maintenance	23-24
■ Exploded View and Parts List	25-27
■ Sears Repair Parts Phone Numbers	Back Cover

WARRANTY

TWO YEAR LIMITED WARRANTY ON CRAFTSMAN® PROFESSIONAL TOOL

If this Craftsman Professional tool fails due to a defect in material or workmanship, **RETURN IT TO THE NEAREST SEARS STORE OR OTHER CRAFTSMAN OUTLET IN THE UNITED STATES** for free replacement during the first year from the date of purchase, and for free repair during the second year from the date of purchase.

This warranty does not include expendable parts such as lamps, batteries, bits or blades.

This warranty gives you specific legal rights, and you may also have other rights which vary from state to state.

Sears, Roebuck and Co., Hoffman Estates, IL 60179

INTRODUCTION

SAVE THESE INSTRUCTIONS! READ ALL INSTRUCTIONS!



This Hammer Drill/Driver has many features for making its use more pleasant and enjoyable. Safety, performance and dependability have been given top priority in the design of this product making it easy to maintain and operate.

⚠ WARNING: Some dust created by using power tools contains chemicals known to the state of California to cause cancer and birth defects or other reproductive harm.

SAFETY SYMBOLS

The purpose of safety symbols is to attract your attention to possible dangers. The safety symbols and the explanations with them deserve your careful attention and understanding. The symbol warnings DO NOT by themselves eliminate any danger. The instructions and warnings they give are no substitutes for proper accident prevention measures.

⚠ WARNING: BE SURE to read and understand all safety alert symbols such as “DANGER”, “WARNING” and “CAUTION” BEFORE using this product. Failure to follow all instructions may result in electric shock, fire and/or serious personal injury.

SYMBOL	SIGNAL	MEANING
	DANGER:	Indicates an imminently hazardous situation, which, if not avoided, will result in death or serious injury.
	WARNING:	Indicates a potentially hazardous situation, which, if not avoided, could result in death or serious injury.
	CAUTION:	Indicates a potentially hazardous situation, which, if not avoided, may result in minor or moderate injury.
	CAUTION:	(Without Safety Alert Symbol) Indicates a situation that may result in property damage.

⚠ WARNING: To ensure safety and reliability, all repairs should be performed by a qualified service technician at Sears Service Center.





⚠ WARNING: The operation of any power tool can result in foreign objects being thrown into your eyes, which can result in severe eye damage. Before beginning power tool operation, always wear safety goggles or safety glasses with side shields and a full face shield when needed. We recommend Wide Vision Safety Mask for use over eyeglasses or standard safety glasses with side shields. Always use eye protection which is marked to comply with ANSI Z87.1.

SAVE THESE INSTRUCTIONS

SAFETY SYMBOLS

Some of these following symbols may be used on this tool. Please study them and learn their meaning. Proper interpretation of these symbols will allow you to operate the tool better and safer.

SYMBOL	NAME	DESIGNATION/EXPLANATION
V	Volts	Voltage
A	Amperes	Current
Hz	Hertz	Frequency (cycles per second)
W	Watt	Power
min	Minutes	Time
	Alternating Current	Type of current
	Direct Current	Type or a characteristic of current
n_0	No Load Speed	Rotational speed, at no load
	Class II Construction	Double-insulated construction
.../min	Per Minute	Revolutions, strokes, surface speed, orbits, etc., per minute
	Wet Conditions Alert	Do not expose to rain or use in damp locations.
	Read The Operator's Manual	To reduce the risk of injury, user must read and understand operator's manual before using this product.
	Eye Protection	Always wear safety goggles or safety glasses with side shields and a full face shield when operating this product.
	Safety Alert	Precautions that involve your safety.
	No Hands Symbol	Failure to keep your hands away from the blade will result in serious personal injury.
	No Hands Symbol	Failure to keep your hands away from the blade will result in serious personal injury.
	No Hands Symbol	Failure to keep your hands away from the blade will result in serious personal injury.
	No Hands Symbol	Failure to keep your hands away from the blade will result in serious personal injury.
	Hot Surface	To reduce the risk of injury or damage, avoid contact with any hot surface.

GENERAL SAFETY RULES

⚠️ WARNING: READ AND UNDERSTAND ALL INSTRUCTIONS. Failure to follow all instructions listed below may result in electric shock, fire and/or serious personal injury. The term “power tool” in all of the warnings listed below refer to mains-operated (corded) power tools or battery-operated (cordless) power tools.

SAVE THESE INSTRUCTIONS

WORK AREA SAFETY

- **Keep work area clean and well lit.** Cluttered or dark areas invite accidents.
- **Do not operate power tools in explosive atmospheres, such as in the presence of flammable liquids, gases or dust.** Power tools create sparks which may ignite the dust or fumes.
- **Keep children and bystanders away while operating a power tool.** Distractions cause you to lose control.

ELECTRICAL SAFETY

- **Power tool plugs must match the outlet. Never modify the plug in any way. Do not use any adapter plugs with earthed (grounded) power tools.** Unmodified plugs and matching outlets will reduce the risk of electric shock.
- **Avoid body contact with earthed (grounded) surfaces such as pipes, radiators, ranges and refrigerators. There is an increased risk of electric shock if your body is earthed (grounded).**
- **Do not expose power tools to rain or wet conditions.** Water entering a power tool will increase the risk of electric shock.
- **Do not abuse the cord. Never use the cord for carrying, pulling or unplugging the power tool. Keep cord away from heat, oil, sharp edges or moving parts. Damaged or entangled cords increase the risk of electric shock.**
- **When operating a power tool outdoors, use an extension cord suitable for outdoor use. Use of a cord suitable for outdoor use reduces the risk of electric shock.**
- **Use battery only with charger listed.**

BATTERY PACK	CHARGER	CHARGER
320.25708	320.25709	320.257091

PERSONAL SAFETY

- **Stay alert, watch what you are doing and use common sense when operating a power tool. Do not use a power tool while you are tired or under the influence of drugs, alcohol or medication.** A moment of inattention while operating power tools may result in serious personal injury.
- **Use safety equipment. Always wear eye protection.** Safety equipment such as dust masks, non-skid safety shoes, hard hat or hearing protection used for appropriate conditions will reduce personal injuries.
- **Avoid accidental starting. Ensure the switch is in the off position before plugging in.** Carrying power tools with your finger on the switch or plugging in power tools that have the switch on invites accidents.
- **Remove any adjusting key or wrench before turning the power tool on.** A wrench or key left attached to a rotating part of the power tool may result in personal injury.
- **Do not overreach. Keep proper footing and balance at all times.** This enables better control of the power tool in unexpected situations.

GENERAL SAFETY RULES

- **Dress properly. Do not wear loose clothing or jewelry. Keep your hair, clothing and gloves away from moving parts.** Loose clothes, jewelry or long hair can be caught in moving parts.
- **If devices are provided for the connection of dust extraction and collection facilities, ensure these are connected and properly used.** Use of these devices can reduce dust-related hazards.
- **Do not wear loose clothing or jewelry. Contain long hair.** Loose clothes, jewelry or long hair can be drawn into air vents.
- **Do not use on a ladder or unstable support.** Stable footing on a solid surface enables better control of the power tool in unexpected situations.

POWER TOOL USE AND CARE

- **Do not force the power tool. Use the correct power tool for your application.** The correct power tool will do the job better and safer at the rate for which it was designated.
- **Do not use the power tool if the switch does not turn it on or off.** Any power tool that cannot be controlled with the switch is dangerous and must be repaired.
- **Disconnect the plug from the power source and/or the batter pack from the power tool before making any adjustments, changing accessories or storing power tools.** Such preventive safety measures reduce the risk of starting the power tool accidentally.
- **Store idle power tools out of the reach of children and do not allow persons unfamiliar with the power tool or these instructions to operate the power tool.** Power tools are dangerous in the hands of untrained users.
- **Maintain power tools. Check for misalignment or binding of moving parts, breakage of parts and any other condition that may affect the power tool's operation. If damaged, have the power tool repaired before use.** Many accidents are caused by poorly maintained power tools.
- **Keep cutting tools sharp and clean.** Properly maintained cutting tools with sharp cutting edges are less likely to bind and are easier to control.
- **Use the power tool, accessories and tool bits etc., in accordance with these instructions and in the manner intended for the particular type of power tool, taking in account the working conditions and the work to be performed.** Use of the power tool for operations different from those intended could result in a hazardous situation.

BATTERY TOOL USE AND CARE

- **Ensure the switch is in the off position before inserting battery pack.** Inserting the battery pack into power tools that have the switch on invites accidents.
- **Recharge only with the charger specified by the manufacturer.** A charger that is suitable for one type of batter pack may create a risk of fire when used with another battery pack.
- **Use power tools only with specifically designated battery packs.** Use of any other battery packs may create a risk of injury and fire.
- **When battery pack is not in use, keep it away from other metal objects like paper clips, coins, keys, nails screws or other small metal objects that can make a connection from one terminal to another.** Shorting the battery terminals together may cause burns or a fire.
- **Under abusive conditions, liquid may be ejected from the battery, avoid contact. If contact accidentally occurs, flush with water. If liquid contacts eyes, additionally seek medical help.** Liquid ejected from the battery may cause irritation or burns.

⚠ WARNING: To reduce the risk of injury, user must read instruction manual

GENERAL SAFETY RULES

SERVICE

- **Have your power tool serviced by a qualified repair person using only identical replacement parts.** This will ensure that the safety of the power tool is maintained.
- **When servicing a power tool, use only identical replacement parts. Follow instructions in the Maintenance section of this manual.** Use of unauthorized parts or failure to follow Maintenance instructions may create a risk of shock or injury.

SPECIFIC SAFETY RULES

- **Use auxiliary handle supplied with the tool.** Loss of control can cause personal injury.
- **Hold power tools by insulated gripping surfaces when performing an operation where the cutting tool may contact hidden wiring or its own cord.** Contact with a “live” wire will also make exposed metal parts of the tool “live” and shock the operator.
- **Use clamps or another practical way to secure and support the workpiece to a stable platform.** Holding the work by hand or against your body leaves it unstable and may lead to loss of control.
- **Know your power tool. Read operator’s manual carefully. Learn its applications and limitations, as well as the specific potential hazards related to this tool.** Following this rule will reduce the risk of electric shock, fire or serious injury.
- **Always wear safety glasses with side shields. Everyday glasses have only impact resistant lenses. They are NOT safety glasses.** Following this rule will reduce the risk of eye injury.
- **Protect your lungs. Wear a face or dust mask if the operation is dusty.** Following this rule will reduce the risk of serious personal injury.
- **Protect your hearing. Wear hearing protection during extended periods of operation.** Following this rule will reduce the risk of serious person injury.
- **Battery tools do not have to be plugged into an electrical outlet; therefore, they are always in operating condition. Be aware of possible hazards when not using your battery tool or when changing accessories.** Following this rule will reduce the risk of electric shock, fire or serious personal injury.
- **Do not place battery tools or their batteries near fire or heat.** This will reduce the risk of explosion and possibly injury.
- **Do not crush, drop or damage battery pack. Do not use a battery pack or charger that has been dropped or received a sharp blow.** A damaged battery is subject to explosion. Properly dispose of a dropped or damaged battery immediately.
- **Batteries vent hydrogen gas and can explode in the presence of a source of ignition such as a pilot light.** To reduce the risk of serious personal injury, never use any cordless product in the presence of open flame. An exploded battery can propel debris and chemicals. If exposed, flush with water immediately.
- **Do not charge battery tool in a damp or wet location.** Following this rule will reduce the risk of electric shock.
- **For best results, your battery tool should be charged in a location where the temperature is more that 32°F (0°C) but less that 104°F (40°C). Do not store outside or in vehicles.**
- **Under extreme usage or temperature conditions, battery leakage may occur. If liquid comes in contact with your skin, wash immediately wit soap and water, then neutralize with lemon juice or vinegar. If liquid gets in your eyes, flush them with clean water for at least 10 minutes, then seek immediate medical attention.** Following this rule will reduce the risk of serious personal injury.
- **Save these instructions.** Refer to them frequently and use them to instruct others who may use this tool. If you loan someone this tool, also loan them these instructions.
- **If the power supply cord is damaged, it must be replaced only by the manufacturer or by an authorized service center to avoid risk.**

SAFETY RULES FOR CHARGER

⚠ WARNING: READ AND UNDERSTAND ALL INSTRUCTIONS. Failure to follow all instructions listed below may result in electric shock, fire and/or serious personal injury.

- **Before using battery charger**, read all instructions and cautionary markings in this manual, on battery charger, battery and product using battery to prevent misuse of the products and possible injury or damage.

⚠ CAUTION: To reduce the risk of electric shock or damage to the charger and battery, charge only lithium-ion rechargeable batteries as specifically designated on your charger. Other types of batteries may burst, causing personal injury or damage.

- **Do not use charger, outdoors or expose to wet or damp conditions.** Water entering charger, will increase the risk of electric shock.
- **Use of an attachment not recommended or sold by the battery charger, manufacturer may result in a risk of fire, electric shock or injury to persons.** Following this rule will reduce the risk of electric shock, fire or serious personal injury.
- **Do not abuse cord or charger,** Never use the cord to carry the charger, Do not pull the charger cord rather than the plug when disconnecting from receptacle. Damage to the cord or charger could occur and create an electric shock hazard. Replace damaged cords immediately.
- **Make sure cord is located so that it will not be stepped on, tripped over, come in contact with sharp edges or moving parts or otherwise subjected to damage or stress.** This will reduce the risk of accidental falls, which could cause injury and damage to the cord, which could result in electric shock.
- **Keep cord and charger from heat to prevent damage to housing or internal parts.**
- **Do not let gasoline, oils, petroleum-based products, etc. come in contact with plastic parts.** They contain chemicals that can damage, weaken or destroy plastic.
- **An extension cord should not be used unless absolutely necessary. Use of improper extension cord could result in a risk of fire and electric shock. If an extension cord must be used, make sure:**
 1. That pins on plug of extension cord are the same number, size and shape as those of plug on charger.
 2. That extension cord is properly wired and in good electrical condition; and
 3. That wire size is large enough for AC ampere rating of charger as specified below:

Cord Length (Feet)	25'	50'	100'
Cord Size (AWG)	16	16	16
- **NOTE:** AWG = American Wire Gauge
- **Do not operate charger with a damaged cord or plug,** which could cause shorting and electric shock. If damaged, have the charger repaired or replaced by an authorized service technician at Sears Service Center.
- **Do not operate charger if it has received a sharp blow, been dropped or otherwise damaged in any way.** Take it to an authorized service technician at Sears Service Center for an electrical check to determine if the charger is in good working order.
- **Do not disassemble charger.** Take it to an authorized service technician at Sears Service Center when service or repair is required. Incorrect reassembly may result in a risk of electric shock or fire.
- **Unplug charger from outlet before attempting any maintenance or cleaning to reduce the risk of electric shock.**

SAFETY RULES FOR CHARGER

- **Disconnect charger from the power supply when not in use.** This will reduce the risk of electric shock or damage to the charger if metal items should fall into the opening. It will also help prevent damage to the charger during a power surge.
- **Risk of electric shock.** Do not touch uninsulated portion of output connector or uninsulated battery terminal.
- **Save these instructions.** Refer to them frequently and use them to instruct others who may use this tool. If you loan someone this tool, loan them these instructions also to prevent misuse of the product and possible injury.

IMPORTANT SAFETY INSTRUCTIONS

- **SAVE THESE INSTRUCTIONS.** This manual contains important safety and operating instructions for battery charger 320.25709, charger 320.257091 and battery pack 320.25708.
- **Before using battery charger,** read all instructions and cautionary markings on battery charger, battery and product using battery.
- **CAUTION.** To reduce the risk of injury, charge only lithium-ion rechargeable batteries. Other types of batteries may burst, causing personal injury or damage.

▲WARNING: Use of this product can generate dust containing chemicals known to the state of California to cause cancer, birth defects or other reproductive harm. Some examples of these chemicals are:

- Lead from lead-based paints.
- Crystalline silica from bricks and cement and other masonry products.
- Arsenic and chromium, from chemically treated lumber.

Your risk from these exposures varies, depending upon how often you do this type of work. To reduce your exposure to these chemicals:

- Work in a well-ventilated area.
- Work with approved safety equipment, such as those dust masks that are specially designed to filter out microscopic particles.

Avoid prolonged contact with dust from power sanding, sawing, grinding, drilling and other construction activities. Wear protective clothing and wash exposed areas with soap and water. Allowing dust to get into your mouth, eyes or lay on the skin may promote absorption of harmful chemicals.

DESCRIPTION

Fig. 1

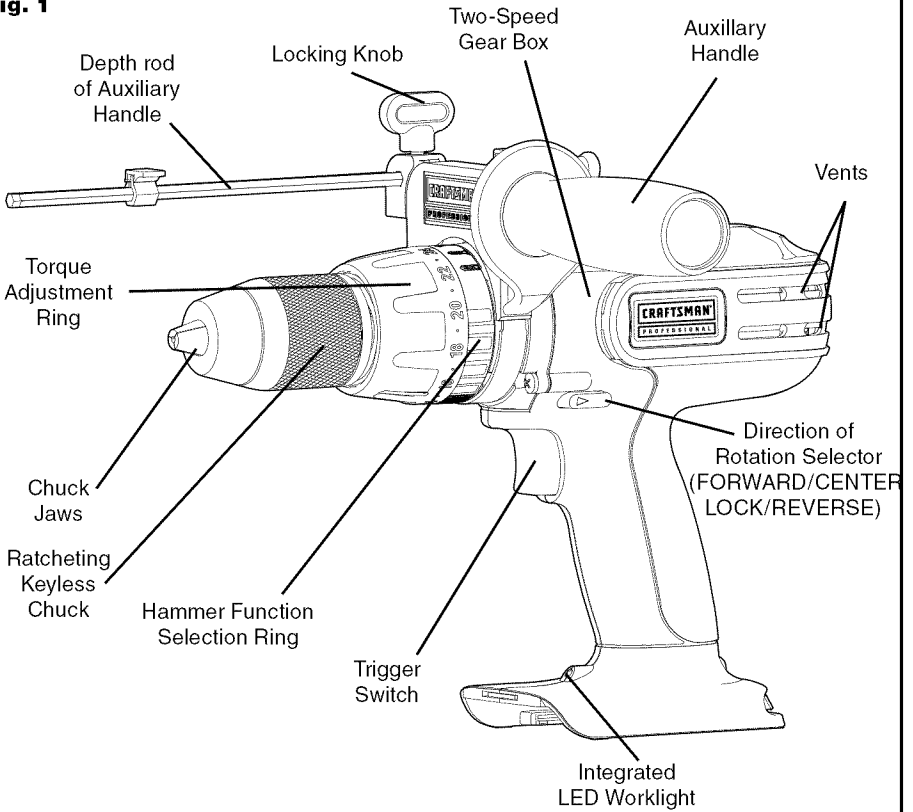

PRODUCT SPECIFICATIONS

Chuck	1/2-in. Ratcheting, single-sleeve keyless
Motor	20 Volt DC
Switch	VSR (Variable Speed Reversible)
No Load Speed	LO 0-350 / HI 0-1,300 (RPM)
No load BPM	LO 0-6300/ HI 0-23400
Clutch	24 Position
Torque	540 in. lbs.
Hammer Drill/Driver Weight (without battery)	4.2 lbs.
Battery Type	Lithium-Ion
Battery Voltage	20.0 Volt DC
Charger Input	120-Volts, 60 Hz AC only
Optimum Charging Temperature	32°F (0° C) -104°F (40°C)

DESCRIPTION

KNOW YOUR HAMMER DRILL/DRIVER (Fig. 1)

⚠ WARNING: The safe use of this product requires an understanding of the information on the tool and in this operator's manual as well as a knowledge of the project you are attempting. Before use of this product, familiarize yourself with all operating features and safety rules.

ADJUSTABLE TORQUE

The drill has a 24-position clutch. The torque adjustment clutch can be turned to select the right amount of torque for your application.

TWO-SPEED GEAR BOX

The two-speed gear box is designed for drilling or driving at LO or HI speeds. A slide switch is located on top of your drill for selecting the appropriate speed.

VARIABLE SPEED

The variable speed trigger switch delivers higher speed with increased trigger pressure and lower speed with decreased trigger pressure.

RATCHETING KEYLESS CHUCK

The keyless chuck allows you to hand-tighten or release the drill bit in the chuck jaws. The ratcheting feature is designed to prevent the chuck from opening during operation.

FORWARD/REVERSE/CENTER LOCK

The drill has a direction of rotation selector located above the trigger switch for changing the direction of bit rotation. Setting the trigger switch in the OFF (center lock) position helps reduce the possibility of accidental starting when not in use.

HAMMER FUNCTION

The hammer drill/driver comes with hammer function for heavy location use.

AUXILIARY HANDLE

The drill is equipped with an auxiliary handle for ease of operation and to prevent loss of control.

LED WORKLIGHT

The LED worklight, located on the front of the drill base, illuminates when the trigger switch is depressed. This feature provides extra light for increased visibility.

ASSEMBLY

NOTE: If any parts are broken or missing, DO NOT attempt to plug in the power cord or operate drill until the broken or missing parts are replaced. Failure to do so could result in possible serious injury.

NOTE: Do not attempt to modify this drill or create accessories not recommended for use with this drill. Any such alteration or modification is misuse and could result in a hazardous condition leading to possible serious injury.

⚠ WARNING: To prevent accidental starting that could cause serious personal injury, always remove the battery pack from the drill when assembling parts.

UNPACKING

This product has been shipped completely assembled.

- Carefully remove the tool and any accessories from the box. Make sure that all items listed in the packing list are included.
- Inspect the tool carefully to make sure no breakage or damage occurred during shipping.
- Do not discard the packing material until you have carefully inspected and satisfactorily operated the drill.
- If any parts are damaged or missing, please refer to the numbers listed on the back page of operator's manual.

PACKING LIST

Hammer Drill/Driver with Auxiliary Handle, Double-ended Bit, Carry Bag, 2 Lithium-ion batteries, Operator's Manual

OPERATION

POWER BAR

- This Lithium-Ion battery pack is equipped with a POWER BAR which is used to display the battery pack's remaining run time. Press the POWER BAR button to display the LED lights. The LED lights will stay lit for approximately 4 seconds.

NOTE: The POWER BAR can be used when the battery is attached or removed from tool.

Fig. 2

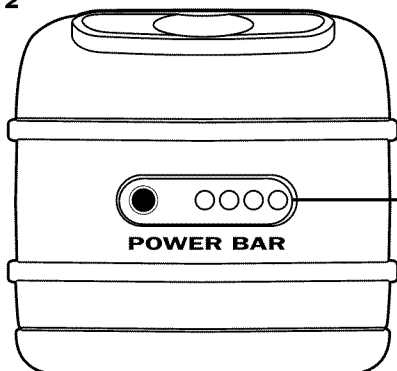

● ● ● ●	80-100% Charge
○ ● ● ●	60-79% Charge
○ ○ ● ●	40-59% Charge
○ ○ ○ ●	20-39% Charge
○ ○ ○ ●	Under 10% Charge
● ● ● ●	Completely discharged

LOW CAPACITY WARNING

- If one LED on the POWER BAR begins to flash, the battery pack's charge is under 10% capacity and should be recharged.
- Unlike other battery pack types, Lithium-Ion battery packs deliver fade-free power for their entire run time. The tool will not experience a slow, gradual loss of power as you work. To signal that the battery pack is at the end of its run time and needs to be charged, power to the tool will drop quickly. The POWER BAR will begin to display four flashing LED lights when it is completely discharged. When this happens, remove the tool from the workpiece and charge the battery pack as needed.

NOTE: The POWER BAR may also display four flashing LED lights due to an overload or high temperature situation (see SmartChip™ Battery protection).

SmartChip™ BATTERY PROTECTION

SmartChip™ intuitive circuitry protects the battery pack from extreme temperature, over-discharge and over-charge. To protect the battery from damage and prolong its life, the battery pack's SmartChip™ circuitry will turn off the battery pack if it becomes overloaded or if the temperature becomes too high during use. This may happen in extremely high torque, binding and stalling situations. This intelligent system will shutdown your battery pack if its operating temperature exceeds 176°F (80°C) and will begin normal operation when it returns to 32°F (0°C) - 122°F (50°C).

- The POWER BAR will display four flashing LED lights if the SmartChip™ circuitry detects a momentary overload. You can conveniently reset the battery pack by pressing the POWER BAR button. Press the POWER BAR button again to display the remaining charge.

NOTE: If the POWER BAR continues to flash four LED lights after reset, place the battery pack on the charger to evaluate the battery condition (see Fig. 4).

OPERATION

NOTE: A significantly reduced run time after fully charging the battery pack indicates that the batteries are near the end of their usable life and must be replaced.

COLD WEATHER OPERATION

- This Lithium-Ion battery pack will provide optimal performance in temperatures between 32°F (0°C) and 104°F (40°C). When the battery pack is very cold, it may “pulse” for the first minute of use to warm itself up. Put the battery pack on a tool and use the tool in a light application. After about a minute, the battery pack will have warmed itself up and will operate normally.

WHEN TO CHARGE THE BATTERY PACK

The Lithium-Ion battery can be charged at any time and will not develop a “memory” when charged after only a partial discharge. It is not necessary to run down the battery pack charge before recharging. Remove the battery pack from the tool when convenient for you and your job.

- Use the POWER BAR to determine when you need to recharge the battery pack.
- You can “top-off” your battery pack’s charge before starting a big job or long period of use.
- Due to Lithium-Ion’s fade-free properties, the only time it is necessary to charge the Lithium-Ion battery pack is when the pack has reached the end of its charge. To signal the end of charge, power to the tool will drop quickly. Charge the battery pack as needed.

OPERATION

HOW TO CHARGE THE BATTERY PACK

NOTE: This Lithium-Ion battery pack is shipped partially charged. Before using it the first time, fully charge the battery pack.

A fully discharged battery pack with a temperature between 32°F (0°C) and 104°F (40°C) will charge in about 50 minutes.

- Charge the Lithium-Ion battery pack only with the correct charger.
- Connect the charger to a power supply.
- Attach the battery pack to the charger by aligning the raised ribs of the battery pack with the slot in the charger. Slide the battery pack onto the charger (Fig. 3, 3a)
- The charger will communicate with the battery pack's SmartChip™ circuitry to evaluate the condition of the battery pack.
- The POWER BAR LED lights will cycle from right to left during charging. This is part of the normal charging operation.
- After charging is complete, the green LED on the charger will come on and the POWER BAR LED lights will go off. The POWER BAR LED lights will not be displayed when the POWER BAR button is pressed while the battery pack is on the charger.
- The battery pack will fully charge, but will not overcharge, if left on the charger.

Fig. 3

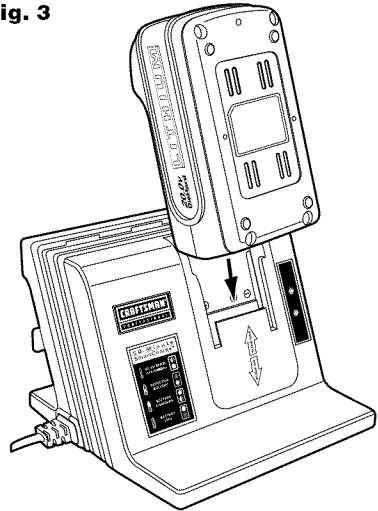

Charger# 320.25709

Fig. 3a

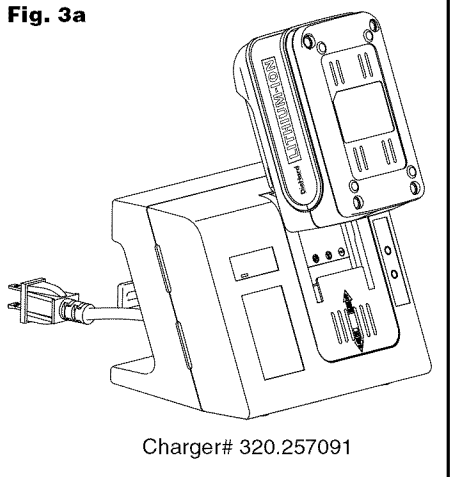









Charger# 320.257091

NOTE: For your convenience, the charger can operate with most generators and inverters rated at 300 watts or higher.

OPERATION

LED FUNCTIONS OF CHARGER (Fig. 4)

Fig. 4

LED INDICATOR	BATTERY PACK	RED LED	GREEN LED	ACTION
 HI/LO TEMP. (SEE MANUAL) 	Hot/Cold battery	On	Off	Charging will begin when battery returns to 32°F (0°C)-104°F (40°C)
 DEFECTIVE BATTERY 	Defective	Flashing	Off	Battery pack or charger is defective
 BATTERY CHARGING 	Charging	Off	Flashing	Charges in 50 minutes
 BATTERY FULL 	Fully charged	Off	On	Charging is complete Maintenance charging

CHARGING A HOT BATTERY PACK

If the battery pack is above normal temperature range, the red LED will be lit and the green LED will be off. When the battery pack cools down to approximately 104°F (40°C), the charger will automatically begin charging.

CHARGING A COLD BATTERY PACK

If the battery pack is below the normal temperature range, the red LED will be lit and the green LED will be off. When the battery warms to a temperature of more than 32°F (0°C), the charger will automatically begin charging.

DEFECTIVE BATTERY

If the charger detects a problem, the red LED will begin flashing and the green LED will be off.

- If defective, remove and reinsert the battery pack in the charger. If the LED status reads “defective” a second time, try charging a different battery pack.
- If a different battery pack charges normally, dispose of the defective battery pack (see Maintenance section).
- If a different battery pack also indicates “defective,” the charger may be defective.

BATTERY CHARGING

If the battery pack is within normal temperature range, the green LED will begin flashing and the red LED will be off. The battery pack will reach a full charge in 50 minutes. The POWER BAR LED lights will cycle right to left during charging. This is part of the normal charging operation. The POWER BAR LED lights will not be displayed when the POWER BAR button is pressed while the battery pack is on the charger.

BATTERY FULL

If the battery pack is within normal temperature range, the green LED will be lit and the red LED will be off. The battery pack is fully charged and ready to use. The battery pack will fully charge, but will not overcharge, if left on the charger. The POWER BAR LED lights will not be displayed when the POWER BAR button is pressed while the battery pack is on the charger.

NOTE: Charger may warm up with several continuous charge cycles. This is part of the normal operation of the charger. Charge in a well ventilated area.

OPERATION

WALL-MOUNT CAPABLE (Fig. 5)

The charger has a key-hole hanging feature for convenient storage. Screws should be installed so that the center distance is 4-1/8-in. Use appropriate wall fasteners to accommodate the combined weight of the charger and battery pack. (approximately 3.5 lbs. combined)

CORD WRAP

The charger is equipped with a cord wrap on the rear of the unit. Utilize this feature to minimize workspace clutter and hazards.

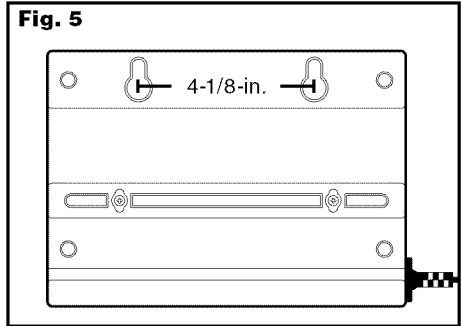

⚠ CAUTION: When placing the battery pack in the tool, be sure the raised rib on the battery pack aligns with the bottom of the drill and latches into place properly. Improper installation of the battery pack can cause damage to internal components.

⚠ WARNING: Do not attempt to modify this drill or create accessories not recommended for use with this drill. Any such alteration or modification is misuse and could result in a hazardous condition leading to possible serious injury.

TO ATTACH BATTERY PACK (Fig. 6)

- Lock the trigger switch on the drill by placing the direction of rotation (forward/reverse/center lock) selector in center position
- Align the raised portion on the battery pack with the grooves on the bottom of the drill, then attach the battery pack to the drill as shown
- Make sure the latch on the battery pack snaps into place and the battery pack is secured to the drill before beginning operation.

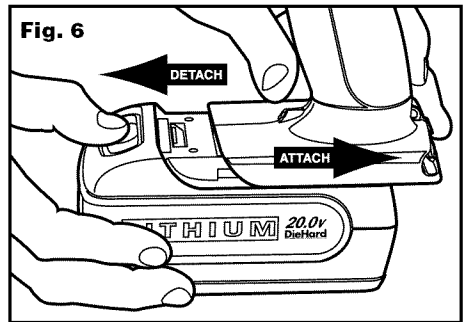

TO DETACH BATTERY PACK (Fig. 6)

- Lock the trigger switch on the drill by placing the direction of rotation (forward/reverse/center lock) selector in center position
- Press the latch located on the front of the battery pack to release battery pack.
- Pull forward on the battery pack to remove from the drill.

⚠ WARNING: Battery tools are always in operating condition. Therefore, direction of rotation selector should always be locked when not in use or carrying at your side.

OPERATION

TRIGGER SWITCH (Fig. 7)

To turn the drill ON, depress the switch trigger.
To turn it OFF, release the trigger.

VARIABLE SPEED (Fig. 7)

The variable speed trigger switch delivers higher speed with increased trigger pressure and lower speed with decreased trigger pressure.

DIRECTION OF ROTATION SELECTOR (FORWARD/REVERSE/CENTER LOCK) (Fig. 7)

The direction of bit rotation is reversible and is controlled by a selector located above the trigger switch.

With the drill held in normal operating position:

- Position the direction of rotation selector to the left of the tool for drilling.
- Position the direction of rotation selector to the right of the tool for reverse.
- Setting the switch in the OFF (center lock) position helps reduce the possibility of accidental starting when not in use.

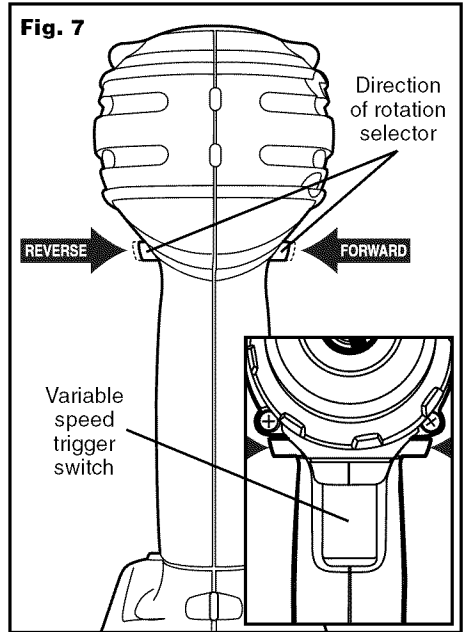

CAUTION: To prevent gear damage, always allow the chuck to come to complete stop before changing the direction of rotation.

NOTE: The drill will not run unless the direction of rotation selector is engaged fully to the left or right.

ELECTRIC BRAKE

To stop the drill, release the trigger switch and allow the chuck to come to a complete stop. The electric brake quickly stops the chuck from rotating. This feature engages automatically when you release the trigger switch.

RATCHETING KEYLESS CHUCK (Fig. 8)

The drill has a ratcheting keyless chuck to tighten or release drill bits in the chuck jaws. The arrows on the chuck indicate which direction to rotate the chuck body in order to GRIP (tighten) or OPEN (release) the chuck jaws on the drill bit. The ratcheting feature is designed to prevent the chuck from opening during operation.

WARNING: Do not hold the chuck body with one hand and use the power of the drill to tighten the chuck jaws on the drill bit. The chuck body could slip in your hand, or your hand could slip and come in contact with the rotating bit. This could cause an accident resulting in serious personal injury.

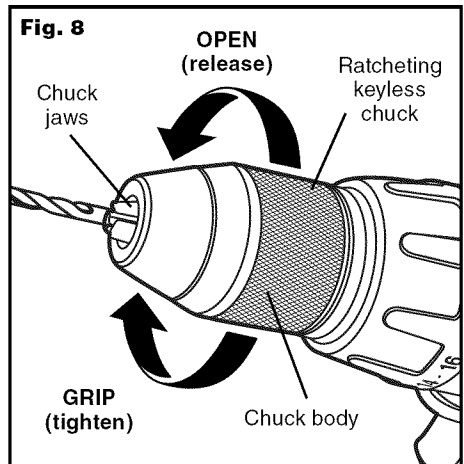

OPERATION

TWO-SPEED GEAR BOX (Fig. 9)

The drill has a two-speed gear box designed for drilling or driving at LO or HI speeds. A slide switch is located on the top of the drill to select either LO or HI speed. When using drill in the LO speed range, speed will decrease and the drill will have more power and torque. When using drill in the HI speed range, speed will increase and the drill will have less power and torque. Use LO speed for high power and torque applications and HI speed for fast drilling or driving applications.

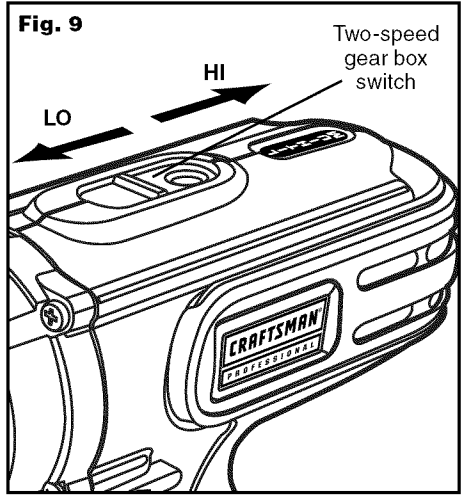

NOTE: Avoid running the drill at LO speed for extended periods of time. Running at LO speed under constant usage may cause the drill to become overheated. If this occurs, cool the drill by running it without a load at HI speed.

CAUTION: Never change gears while the tool is running. Failure to obey this caution could result in serious damage to the drill.

ADJUSTABLE TORQUE CLUTCH (Fig. 10)

When using the hammer drill/driver for different driving applications, it is necessary to increase or decrease the torque in order to help prevent the possibility of damaging screw heads, threads, workpiece, etc. In general, torque intensity should correspond to the screw diameter. If the torque is too high or the screws too small, the screws may be damaged or broken.

The torque is adjusted by rotating the torque adjustment ring.

The torque is greater when the torque adjustment ring is set on a higher setting. The torque is less when the torque adjustment is set on a lower setting.

The proper setting depends on the type of material and the size of screw you are using.

Select the option that best matches the type of bit, fastener and material you will be using.

- Choose the correct speed: LO or HI.
- Choose the correct torque setting.

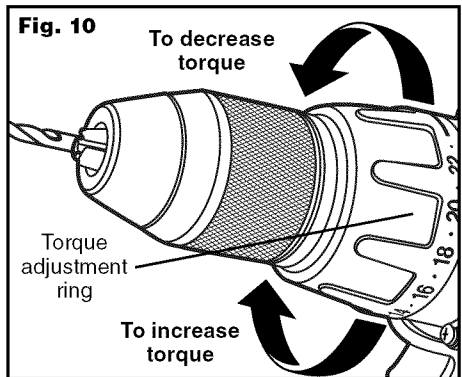

DRILL MODE (Fig. 11)

Select drill mode for drilling and other heavy duty applications.

- To select drill mode, rotate the torque adjustment ring until the  icon aligns with the torque indicator and clicks into position.

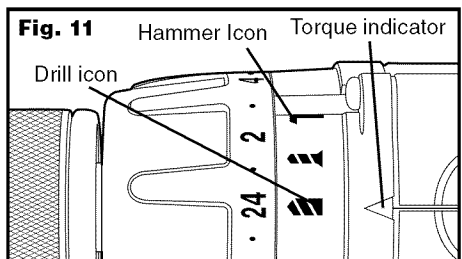

OPERATION

HAMMER MODE (Fig. 11a)

To select hammer mode, rotate the torque adjustment ring until the hammer icon  is aligned with the torque indicator, and clicks into position.

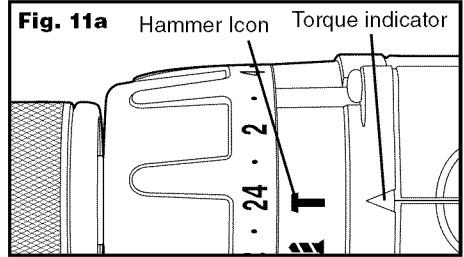

LED WORKLIGHT (Fig. 12)

The LED worklight located on the base of the drill will come on when the trigger switch is depressed. The LED worklight will turn off when the trigger switch is released. This provides additional lighting on the surface of the workpiece for operation in lower-light areas.

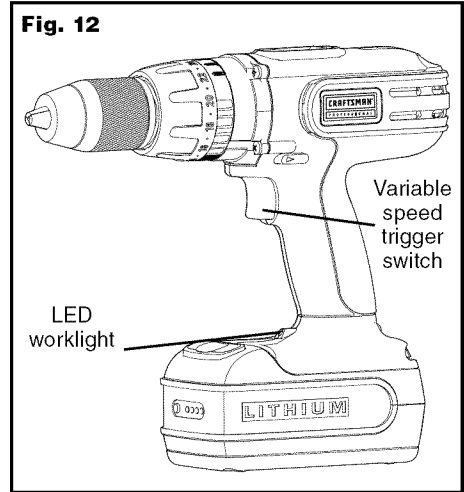

BIT STORAGE (Fig. 13)

When not in use, the bit provided with the drill can be stored on the base of the drill by snapping it into place in the bit clip.

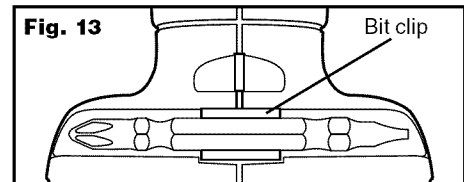

OPERATION

INSTALLING BITS (Fig. 14)

- Lock the trigger switch by placing the direction of rotation selector in the OFF (center) position.
- Open or close the chuck jaws to a point where the opening is slightly larger than the bit size you intend to use. Also, raise the front of the drill slightly to keep the bit from falling out of the chuck jaws.
- Insert a drill bit.

NOTE: Rotate the chuck body in the direction of the arrow marked **GRIP** to close the chuck jaws. Do not use a wrench to tighten or loosen the chuck jaws.

- Tighten the chuck jaws securely on the bit.

REMOVING BITS (Fig. 14)

- Lock the trigger switch by placing the direction of rotation selector in the OFF (center) position.
- Open the chuck jaws.

NOTE: Rotate the chuck body in the direction of the arrow marked **OPEN** to open the chuck jaws. Do not use a wrench to tighten or loosen the chuck jaws.

- Remove the drill bit.

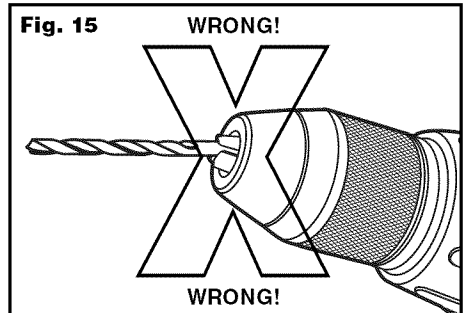
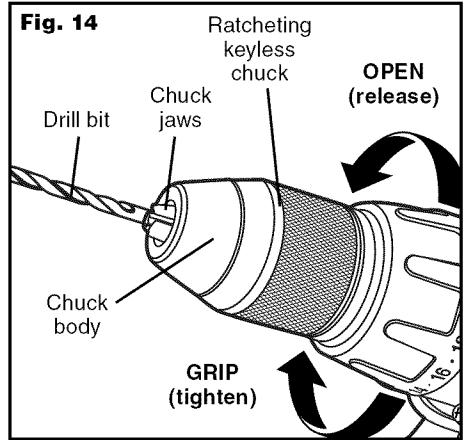

⚠ WARNING: Make sure to insert the drill bit straight into the chuck jaws. Do not insert the drill bit into the chuck jaws at an angle then tighten, as shown in figure 15. This could cause the drill bit to be thrown from the drill, resulting in possible serious personal injury or damage to the chuck.

OPERATION

USING THE AUXILIARY HANDLE ASSEMBLY (Fig. 16)

An auxiliary handle assembly is packed with the drill for ease of operation and to help prevent loss of control. The handle can be rotated 360° and it can also be mounted on the opposite side for left hand use.

- Loosen the handle assembly by turning the handle counterclockwise.
- Rotate the handle assembly to the desired operating position.
- Securely tighten by turning the handle assembly clockwise.
- The auxiliary handle with 2 convenient quick depth stops allows for quickly choosing the depth of drilling.

Be sure the handle assembly is securely tightened against the clamp. This secures the handle assembly.

DRILLING (Fig. 17)

- Check the direction of rotation selector for the correct setting (forward or reverse).
- Secure the material to be drilled in a vise or with clamps to keep it from turning as the drill bit rotates.
- Hold the drill firmly and place the bit at the point to be drilled.
- Depress the trigger switch to start the drill.
- Move the drill bit into the workpiece, applying only enough pressure to keep the bit cutting. Do not force the drill or apply side pressure to elongate a hole. Let the tool do the work.
- When drilling hard, smooth surfaces, use a center punch to mark the desired hole location. This will prevent the drill bit from slipping off-center as the hole is started.
- When drilling metals, use a light oil on the drill bit to keep it from overheating. The oil will prolong the life of the bit and increase the drilling action.
- If the bit jams in the workpiece or if the drill stalls, stop the tool immediately. Remove the bit from the workpiece and determine the reason for jamming.

NOTE: This drill is equipped with an electric brake. When the brake is functioning properly, sparks may be visible through the vent slots in the housing. This is normal and is the action of the brake.

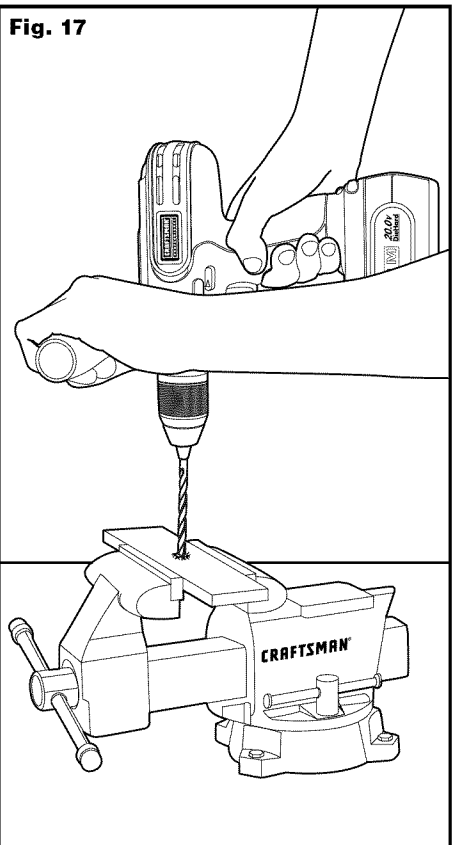
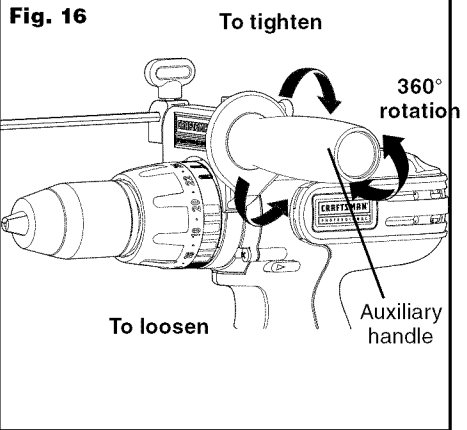

OPERATION

▲WARNING: Be prepared for binding at bit breakthrough. When these situations occur, the drill has a tendency to grab and kick opposite to the direction of rotation and could cause loss of control when breaking through material. If not prepared, this loss of control can result in possible serious injury.

WOOD DRILLING

For maximum performance, use high speed steel or brad point bits for wood drilling.

- Begin drilling at a very low speed to prevent the bit from slipping off the starting point. Increase speed as the drill bit bites into the material.
- When drilling “through” holes, place a block of wood behind the workpiece to prevent ragged or splintered edges on the back side of the hole.

METAL DRILLING

For maximum performance, use high speed steel bits for metal or steel drilling.

- When drilling metals, use a light oil on the drill bit to keep it from overheating. The oil will prolong the life of the bit and increase the drilling action.
- Begin drilling at a very low speed to prevent the bit from slipping off the starting point.
- Maintain a speed and pressure which allows cutting without overheating the bit. Applying too much pressure will:
 - Overheat the drill.
 - Wear the bearings.
 - Bend or burn bits.
 - Produce off-center or irregular-shaped holes.

MASONRY DRILLING

For maximum performance, use carbide-tipped masonry bits when drilling holes in brick, tile, concrete, etc.

- Maintain a speed and pressure which allows cutting without overheating the bit or drill. Applying too much pressure will:
 - Overheat the drill.
 - Wear the bearings.
 - Bend or burn bits.
 - Produce off-center or irregular-shaped holes.
- Apply light pressure and medium speed for best results in brick.
- Apply additional pressure for hard materials such as concrete.
- When drilling holes in tile, practice on a scrap piece to determine the best speed and pressure. Begin drilling at a very low speed to prevent the bit from slipping off the starting point.

▲WARNING: Always wear safety goggles or safety glasses with side shields during power tool operation or when blowing dust. If operation is dusty, also wear a dust mask.

▲WARNING: To ensure safety and reliability, all repairs should be performed by a qualified service technician at Sears Service Center.

MAINTENANCE

GENERAL MAINTENANCE

Avoid using solvents when cleaning plastic parts. Most plastics are susceptible to damage from various types of commercial solvents and may be damaged by their use. Use clean cloths to remove dirt, dust, oil, grease, etc.

▲WARNING: Do not at any time let brake fluids, gasoline, petroleum-based products, penetrating oils, etc., come in contact with plastic parts. Chemicals can damage, weaken or destroy plastic which may result in serious personal injury.

▲WARNING: To avoid serious personal injury, always remove the battery pack from the tool and unplug the charger when cleaning or performing any maintenance.

BATTERIES

The battery pack is equipped with Lithium-Ion rechargeable batteries. The duration of use from each charge will depend on the type of work performed.

The batteries in this tool have been designed to provide maximum trouble-free life. Like all batteries, they will eventually wear out. Do not disassemble the battery pack or attempt to replace the batteries. Handling of the batteries, especially when wearing rings and jewelry, could result in a serious burn.

To obtain the longest possible battery life, read and understand the operators manual.

■ It is good practice to unplug the charger and remove the Lithium-Ion battery pack when not in use.

For Lithium-Ion battery pack storage longer than 30 days:

- Store the Lithium-Ion battery pack where the temperature is below 80°F (26°C) and free of moisture.
- Store Lithium-Ion battery packs in a 30%-50% charged condition.
- Every six months of storage, fully charge the Lithium-Ion battery pack.
- Exterior may be cleaned with a cloth or soft non-metallic brush.

BATTERY PACK REMOVAL AND PREPARATION FOR RECYCLING

To preserve natural resources, please recycle or dispose of batteries properly. This product contains lithium-ion batteries. Local, state or federal laws may prohibit disposal of lithium-ion batteries in ordinary trash. Consult your local waste authority for information regarding available recycling and/or disposal options.



▲WARNING: Upon removal, cover the battery pack's terminals with heavy-duty adhesive tape. Do not attempt to destroy or disassemble the battery pack or remove any of its components. Lithium-Ion batteries must be recycled or disposed of properly. Also, never touch the terminals with metal objects and/or body parts as a short circuit may result. Keep away from children. Failure to comply with these warnings could result in fire and/or serious injury.

MAINTENANCE

CHUCK REMOVAL (Fig. 18-20)

The chuck can be removed and replaced by a new one.

- Lock the trigger switch by placing the direction of rotation selector in center position.
- Open the chuck jaws.
- Insert a 5/16-in. or larger hex key into the chuck of the drill and tighten the chuck jaws securely.
- Tap the hex key sharply with a mallet in a clockwise direction. This will loosen the screw in the chuck for easy removal.
- Open the chuck jaws and remove the hex key. Using a screwdriver, remove the chuck screw by turning it in a clockwise direction.

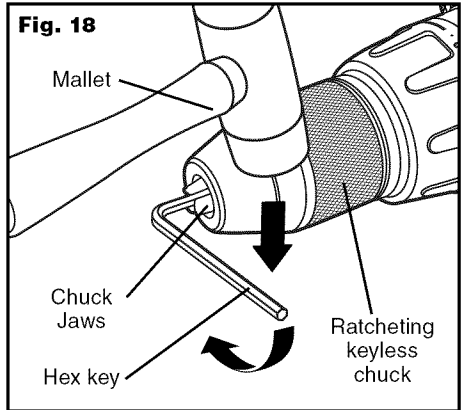

NOTE: The chuck screw has left handed threads.

- Insert the hex key into the chuck and tighten the chuck jaws securely. Tap sharply with a mallet in a counterclockwise direction. This will loosen the chuck on the spindle. It can now be unscrewed by hand.

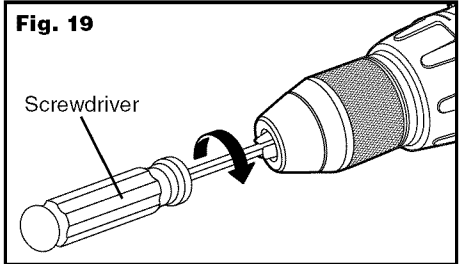

TO RETIGHTEN A LOOSE CHUCK

The chuck may become loose on the spindle and develop a wobble. Also, the chuck screw may become loose, causing the chuck jaws to bind and prevent them from closing.

To tighten a loose chuck or chuck screw:

- Lock the trigger switch by placing the direction of rotation selector in center position.
- Open the chuck jaws.
- Insert the hex key into the chuck and tighten the chuck jaws securely. Tap the hex key sharply with a mallet in a clockwise direction. This will tighten the chuck on the spindle.
- Open the chuck jaws and remove the hex key.
- Using a screwdriver, tighten the chuck screw by turning the chuck screw in a counterclockwise direction.

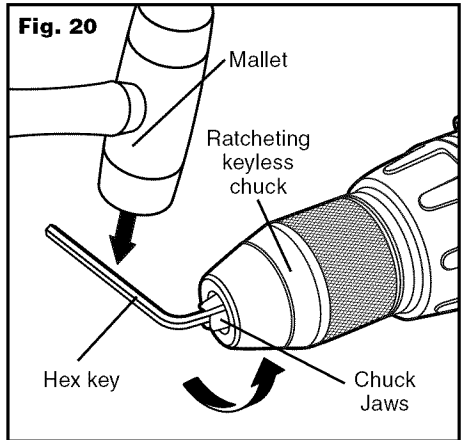

⚠ WARNING: Always wear safety glasses with side shields during maintenance.

⚠ WARNING: To ensure safety and reliability, all repairs should be performed by a qualified service technician at Sears Service Center.

⚠ WARNING: To avoid serious personal injury, always remove the battery pack from the tool and unplug the charger when cleaning or performing any maintenance.

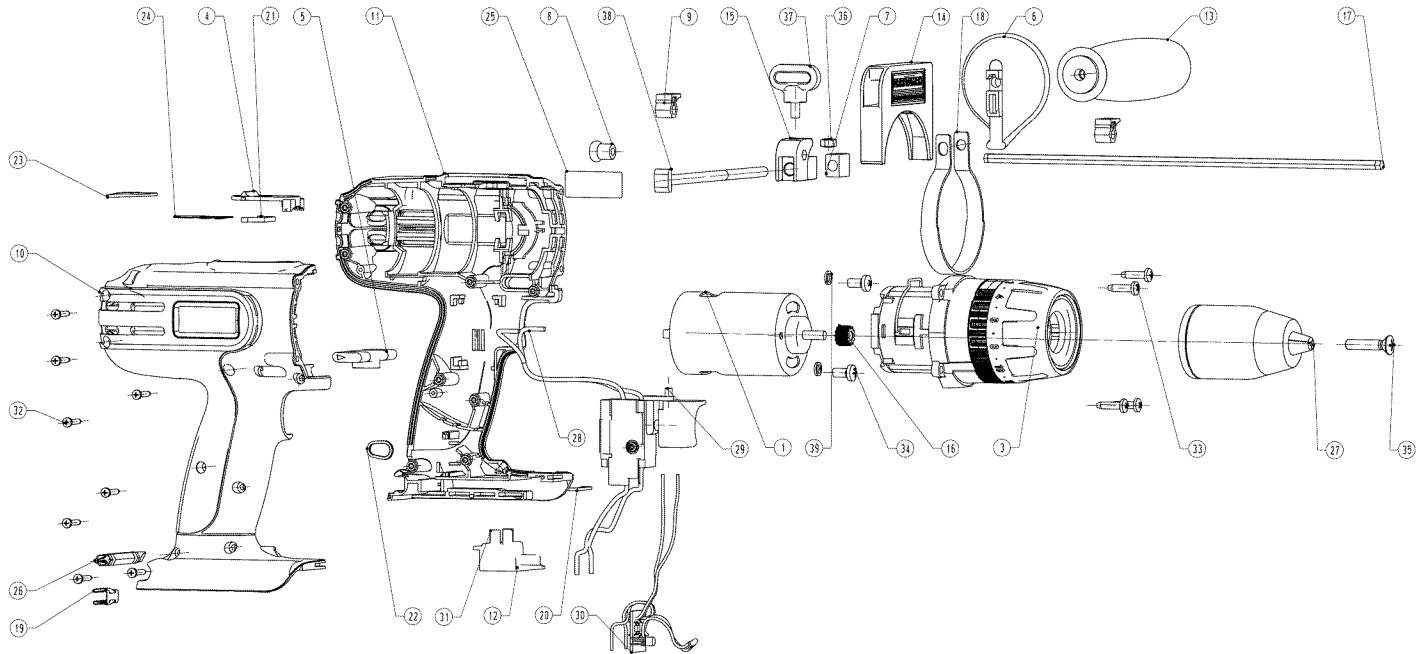

**20.0 VOLT LITHIUM-ION CORDLESS
1/2-in. HAMMER DRILL / DRIVER
MODEL NUMBER 320.29004**

PARTS LIST

20.0 VOLT LITHIUM-ION CORDLESS 1/2-in. HAMMER DRILL/DRIVER MODEL NUMBER 320.29004

The Model Number will be found on the Nameplate attached to the right side of the drill. Always mention the Model Number in all correspondence regarding your tool.

ITEM NO.	PARTS NO.	PART DESCRIPTION	QTY.
1	2730114000	DC Motor	1
2			
3	2790125000	Gear Case ASSY	1
4	3122817000	Speed Change Button	1
5	3122818000	F/R Button	1
6	3122938000	Splint	1
7	3122946000	plate	1
8	3123605000	Lock Ring	1
9	3123608000	Clamp	2
10	3320359000	Right Housing ASSY	1
11	3320360000	Left Housing ASSY	1
12	3400260000	Contact Receptacle ASSY	1
13	3400274000	Handle	1
14	3420500000	Handle Cover	1
15	3420613000	Block	1
16	3520351000	Pinion	1
17	3550953000	Depth Stop	1
18	3660252000	Hadle Hoop	1
19	3700405000	Bits Holder	1
20	3700960000	Handle Hoop	1
21	3700961000	Stop Spring	1
22	3700963000	Lantern Ring	1
23	3700971000	Name Plate	1
24	3700972000	Name Plate	1
25	3700973000	Name Plate	1
26	3810357000	Screw Bit	1
27	3860084000	Chuck	1
28	4860225000	Internal Wire ASSY	1
29	4870303000	Switch	1
30	4890301000	PCB Assembly	1
31	4920180000	Shrinkable Tube	1

PARTS LIST

20.0 VOLT LITHIUM-ION CORDLESS 1/2-in. HAMMER DRILL/DRIVER MODEL NUMBER 320.29004

The Model Number will be found on the Nameplate attached to the right side of the drill. Always mention the Model Number in all correspondence regarding your tool.

ITEM NO.	PARTS NO.	PART DESCRIPTION	QTY.
32	5610013000	Tapping Screw	8
33	5610032000	Tapping Screw	4
34	5620049000	Screw	2
35	5620325000	Screw (L.H.)	1
36	5630003000	Hexagon Nut	1
37	5640047000	Wing Bolt	1
38	5640175000	Lock Bolt	1
39	5650015000	Spring Washer	2

SEE BACK PAGE FOR PARTS ORDERING INSTRUCTIONS

Get it fixed, at your home or ours!

Your Home

For expert troubleshooting and home solutions advice:

manage  home

www.managemyhome.com

For repair – **in your home** – of **all** major brand appliances, lawn and garden equipment, or heating and cooling systems, **no matter who made it, no matter who sold it!**

For the replacement parts, accessories and owner's manuals that you need to do-it-yourself.

For Sears professional installation of home appliances and items like garage door openers and water heaters.

1-800-4-MY-HOME[®]

(1-800-469-4663)

www.sears.com

Call anytime, day or night

(U.S.A. and Canada)

www.sears.ca

Our Home

For repair of carry-in items like vacuums, lawn equipment, and electronics, call anytime for the location of the nearest

Sears Parts & Repair Service Center

1-800-488-1222 (U.S.A.)

www.sears.com

1-800-469-4663 (Canada)

www.sears.ca

To purchase a protection agreement on a product serviced by Sears:

1-800-827-6655 (U.S.A.)

1-800-361-6665 (Canada)

Para pedir servicio de reparación a domicilio, y para ordenar piezas:

1-888-SU-HOGAR[®]

(1-888-784-6427)

Au Canada pour service en français:

1-800-LE-FOYER^{MC}

(1-800-533-6937)

www.sears.ca



© Sears Brands, LLC

® Registered Trademark / TM Trademark / SM Service Mark of Sears Brands, LLC

® Marca Registrada / TM Marca de Fábrica / SM Marca de Servicio de Sears Brands, LLC

^{MC} Marque de commerce / ^{MD} Marque déposée de Sears Brands, LLC