

Operator's Manual

CRAFTSMAN®

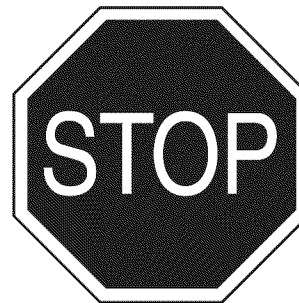

44" HIGHSPEED SWEEPER

Model No. 486.242291

DO NOT RETURN TO STORE
For Missing Parts or Assembly
Questions Call 1-866-576-8388

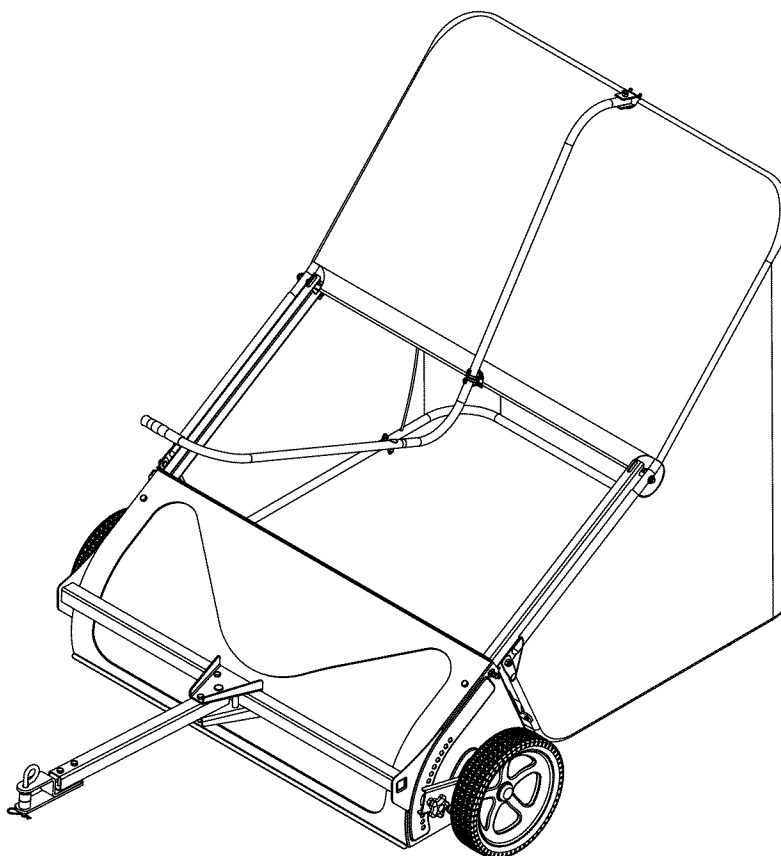

CAUTION:

Before using this product, read this manual and follow all Safety Rules and Operating Instructions.

- Safety
- Assembly
- Operation
- Maintenance
- Parts

Sears, Roebuck and Co., Hoffman Estates, IL 60179 U.S.A.
www.sears.com/craftsman

PRINTED IN U.S.A.

FORM NO. 41502 (09/14/10)

TABLE OF CONTENTS

WARRANTY	2	MAINTENANCE	11
SAFETY RULES.....	3	STORAGE	11
CARTON CONTENTS.....	3	SERVICE AND ADJUSTMENTS.....	12
HARDWARE PACKAGE	4	NOTES	13
ASSEMBLY.....	5	REPAIR PARTS ILLUSTRATION.....	14
OPERATION.....	10	REPAIR PARTS LIST.....	15
TROUBLESHOOTING.....	11	PARTS ORDERING/SERVICE	BACK PAGE

WARRANTY

CRAFTSMAN FULL WARRANTY

When operated and maintained according to all supplied instructions, if this Craftsman product fails due to a defect in material or workmanship within one year from the date of purchase, return it to any Sears store or other Craftsman outlet in the United States for free replacement.

This warranty applies for only 90 days from the date of purchase if this product is ever used for commercial or rental purposes.

This warranty does not include items considered to be expendable parts that can wear out from normal use within the warranty period.

This warranty gives you specific legal rights, and you may also have other rights which vary from state to state.

Sears, Roebuck and Co., D817WA, Hoffman Estates, IL 60179

DO NOT RETURN TO STORE for Missing Parts or Assembly Questions
Call 1-866-576-8388 Attachment Hotline

The model number and serial numbers will be found on a decal attached to the 44" Highspeed Sweeper. You should record both the serial number and the date of purchase and keep in a safe place for future reference.	MODEL NUMBER:	486.242291
	SERIAL NUMBER:	_____
	DATE OF PURCHASE:	_____



SAFETY RULES



Remember, any power equipment can cause injury if operated improperly or if the user does not understand how to operate the equipment. Exercise caution at all times when using power equipment.

- Read the vehicle and sweeper owners manuals and know how to operate your vehicle and sweeper before using this sweeper attachment. Always instruct other users before they operate the sweeper.
- Vehicle braking and stability may be affected with the addition of an accessory or an attachment. Be aware of changing conditions on slopes.
- Do not permit children to operate sweeper.
- Do not permit anyone to ride on sweeper.
- Operate the sweeper at reduced speed on rough terrain, near ditches and on hillsides to prevent loss of control.
- Vehicle braking and stability may be affected with attachment of this sweeper. Do not fill sweeper to maximum capacity without checking capability of the towing vehicle to safely pull and stop with the sweeper attached. Stay off of steep slopes
- Do not exceed 6 m.p.h. Driving too fast may cause damage to sweeper's wheels and bearings.
- Do not hold onto dump handle while tractor is moving.
- Never attach dump handle to tractor or any part of your body. Always keep it secured to the hopper bag while tractor is moving. If any part of dump handle should become damaged, stop use of sweeper and replace the damaged part.
- Stop and inspect vehicle and sweeper for damage after striking an object. Repair any damage before continuing operation.
- Keep sweeper away from fire. Excessive heat can damage the brushes and hopper bag and could cause the bag and its contents to burn.
- Before storing the sweeper, always empty the hopper bag to avoid spontaneous combustion.
- Follow maintenance and lubrication instructions as outlined in the maintenance section of this manual.



Look for this symbol to point out important safety precautions. It means — **Attention! Become alert! Your safety is involved.**

CARTON CONTENTS

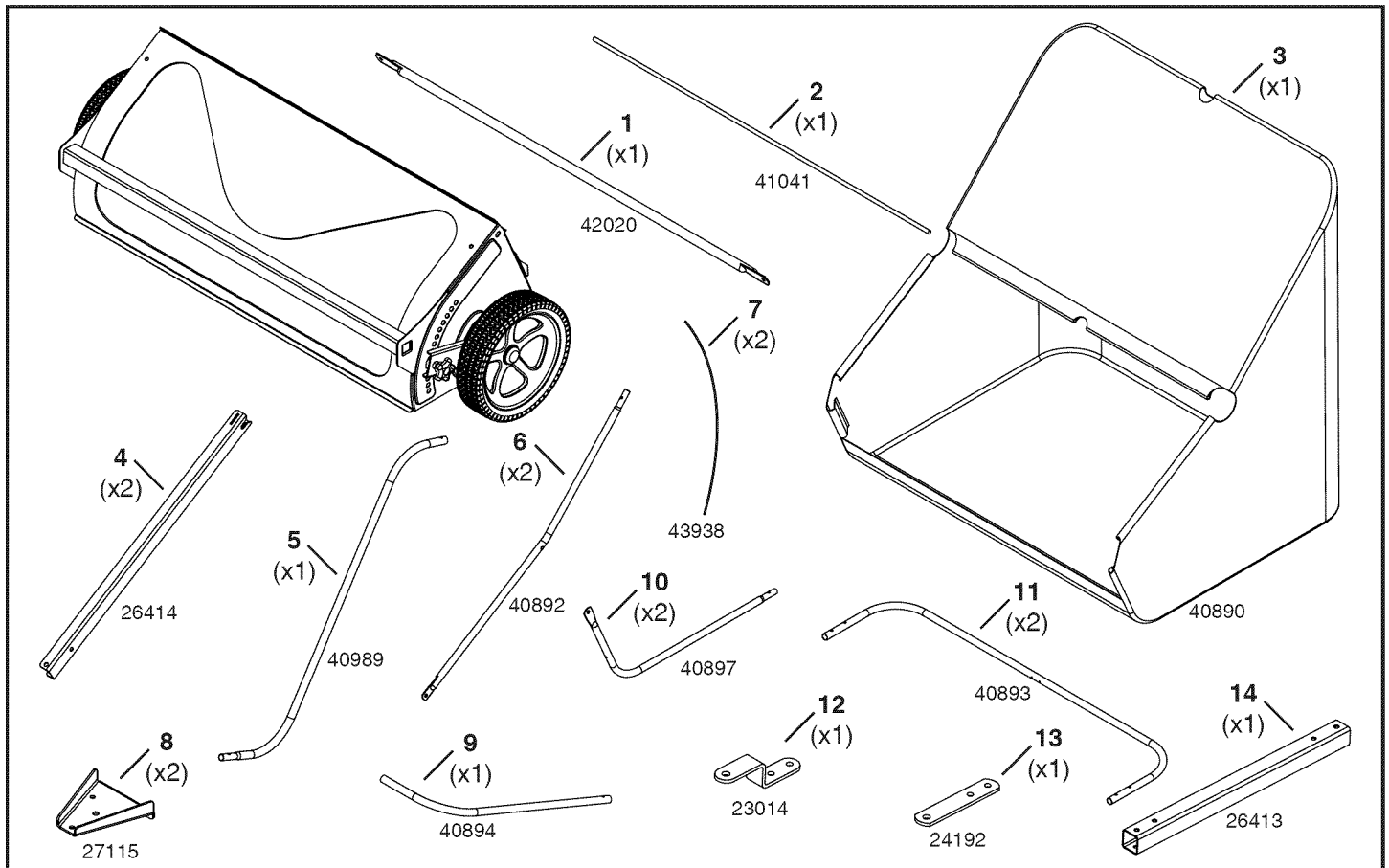

HARDWARE PACKAGE

SHOWN FULL SIZE

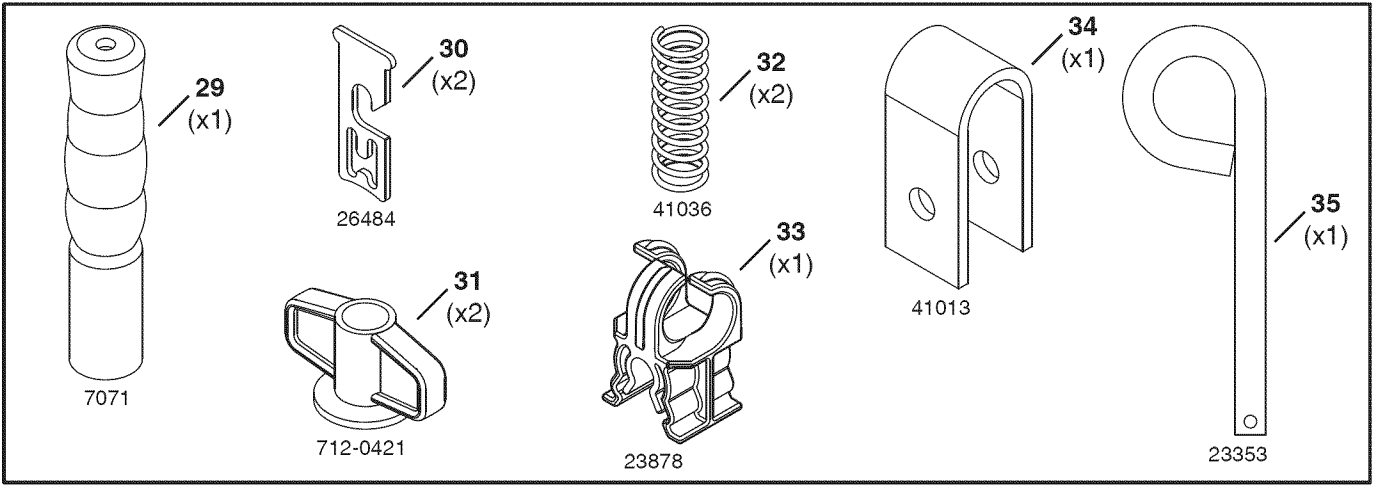
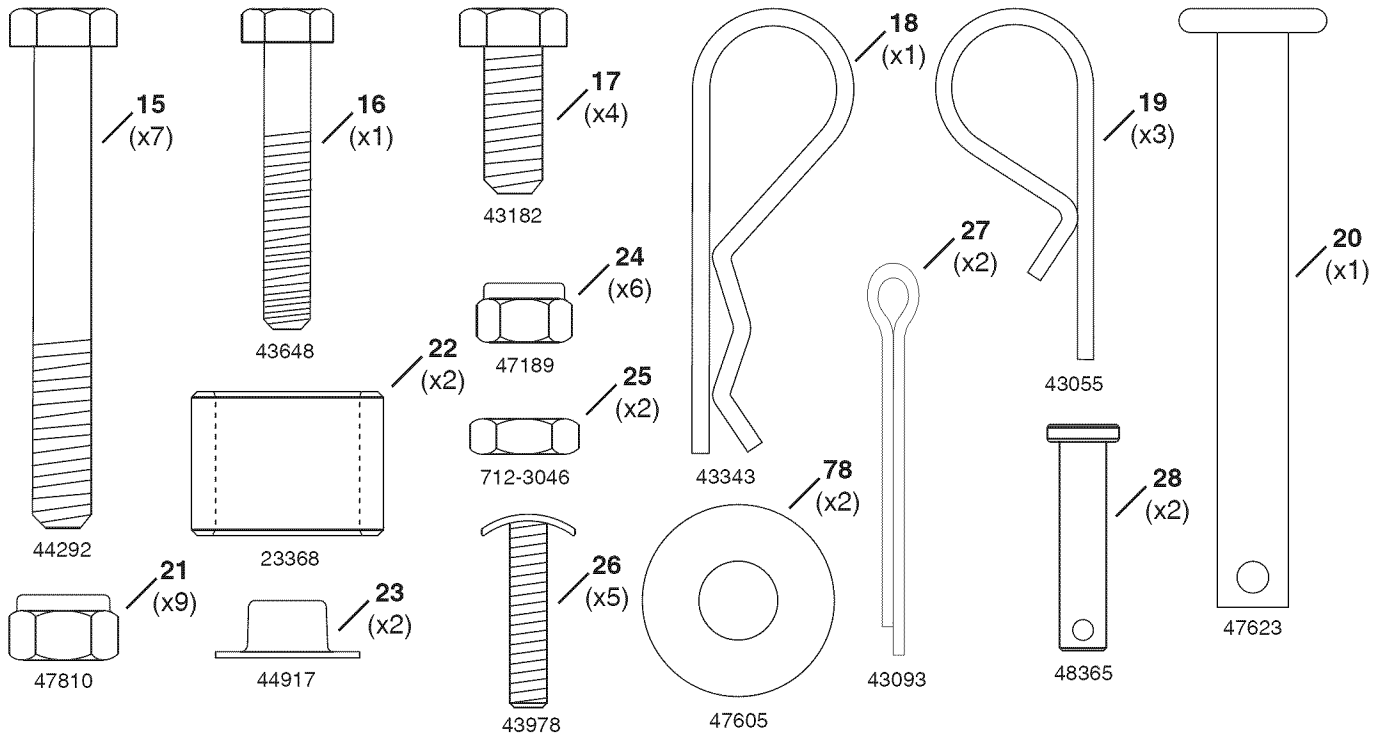

ASSEMBLY

TOOLS REQUIRED FOR ASSEMBLY

- (2) 7/16" Wrenches
- (2) 1/2" Wrench
- (1) Pliers
- (1) Hammer

STEP 1: (SEE FIGURE 1)

- Install a 5/16-18 x 3/4" hex bolt (17) and a 5/16" jam nut (25) in each bag arm channel.

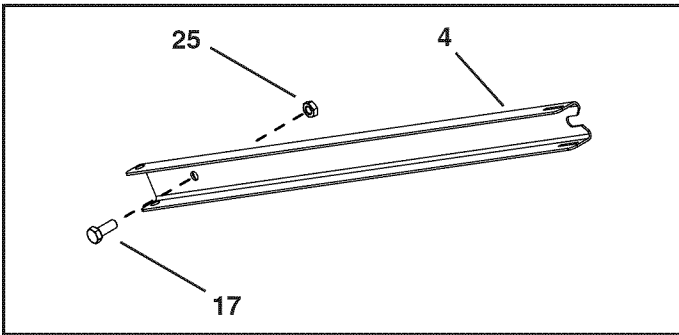

FIGURE 1

STEP 3: (SEE FIGURE 3)

- Secure each bag arm channel to the side of the sweeper housing with a plastic wing nut (31) installed onto the bolt assembled in step 1.
- Insert a pivot rod retainer (30) down into the end of each bag arm channel.
- Install a compression spring (32) into the bottom of each of the pivot rod retainers to secure them to the bag arm channels.

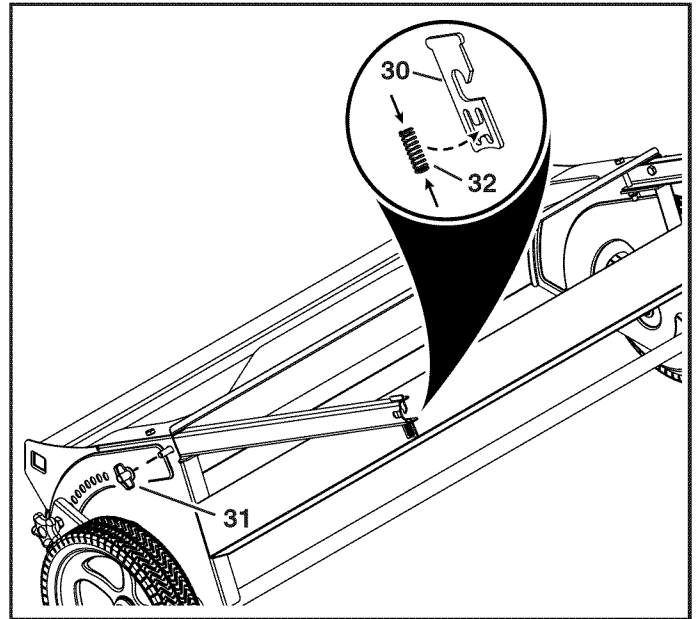

FIGURE 3

STEP 2: (SEE FIGURE 2)

- Slide the bag arm channels (4) into the sweeper housing as shown in figure 2. Secure them to the sweeper housing with a 5/16-18 x 2-1/2" hex bolt (15) and 5/16" nylock nut (21). Tighten bolt until snug. **Do not overtighten.**

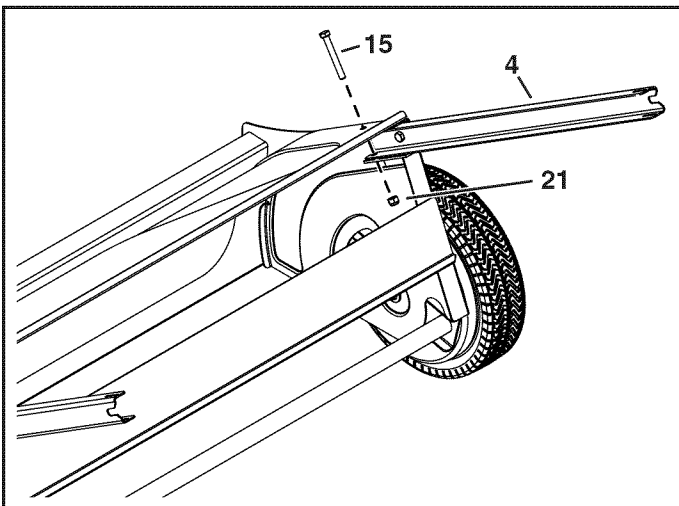

FIGURE 2

STEP 4: (SEE FIGURE 4)

- Attach the drawbar (14) to the sweeper by fastening a drawbar bracket (8) above and below the drawbar using two washers (78), three 5/16" x 2-1/2" hex bolts (15) and 5/16" nylock nuts (21).

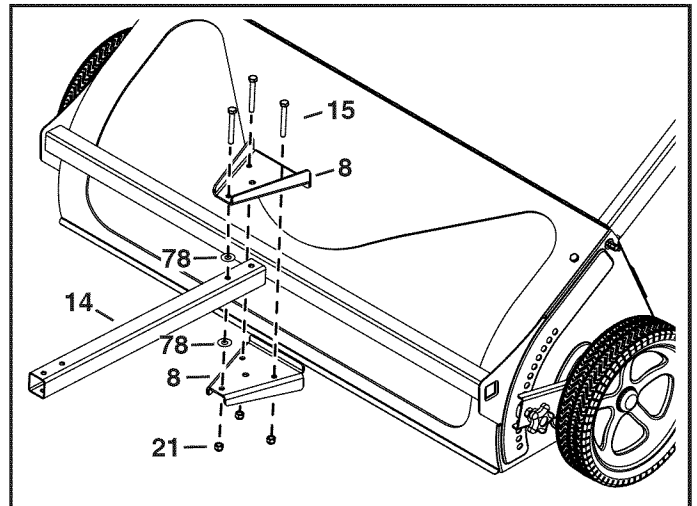

FIGURE 4

STEP 5: (SEE FIGURE 5)

- Lock the drawbar into position by inserting a 3/8" x 3" hitch pin (20) into the center hole and securing it with a 3/32" cotter pin (19).

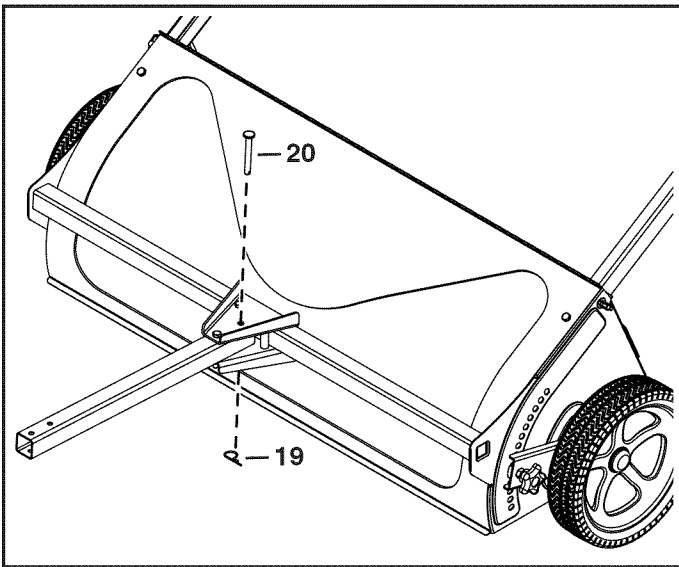

FIGURE 5

STEP 7: (SEE FIGURE 7)

- Slide the bag frame tube (1) through the front flap in the bottom of the bag.
- Slide the two lower hopper tubes (10) into the flaps at the front of the hopper bag (3) as shown.

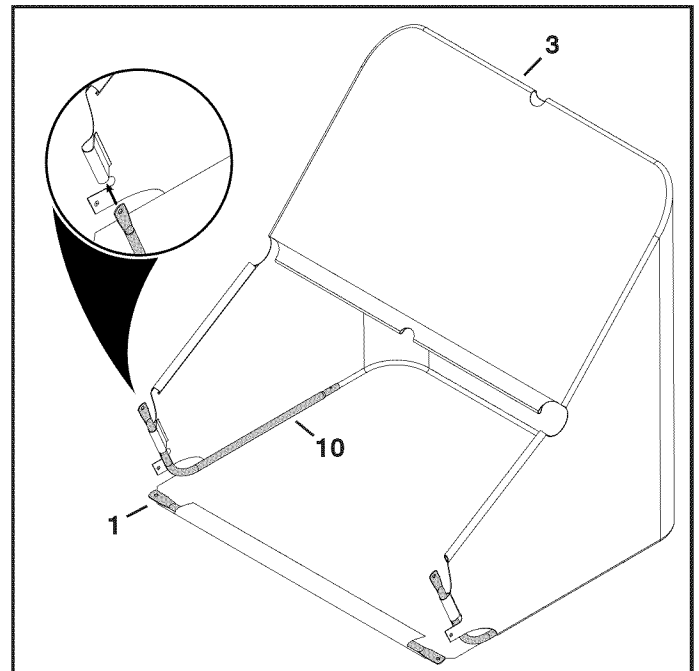

FIGURE 7

STEP 6: (SEE FIGURE 6)

- Attach the hitch bracket (12) and straight hitch bracket (13) to the drawbar using two 5/16" x 2-1/2" hex bolts (15) and 5/16" nylock nuts (21).
- Assemble a 3/8" x 3" hitch pin (35) and two 3/4" spacers (22) to the hitch brackets. Secure them in place with a 3/32" hair cotter pin (18).

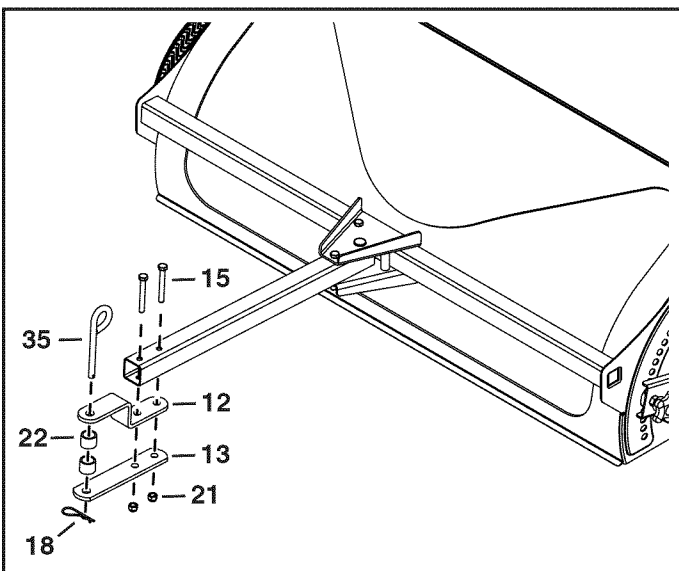

FIGURE 6

STEP 8: (SEE FIGURE 8)

- Install a rear hopper tube (11) onto the ends of the lower hopper tubes (10) making sure the holes in the rear hopper tube are facing up.
- Secure the rear hopper tube (11) to the lower hopper tubes (10) with two 1/4" x 1" curved head bolts (26) and 1/4" nylock nuts (24).

NOTE: Hopper bag (3) not shown for clarity.

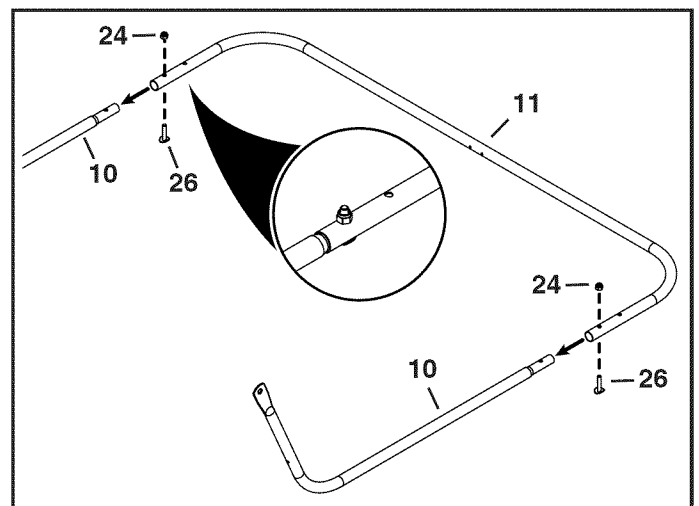

FIGURE 8

STEP 9: (SEE FIGURE 9)

- Slide the front flaps of the hopper bag up onto the front of the lower hopper tubes. Secure the bag frame tube to the lower hopper tubes using two clevis pins (28) and hair pins (19).

NOTE: Be sure front flaps of hopper bag are positioned above clevis pins.

- Snap the sides of the bag to the bottom of the bag at the front corners .

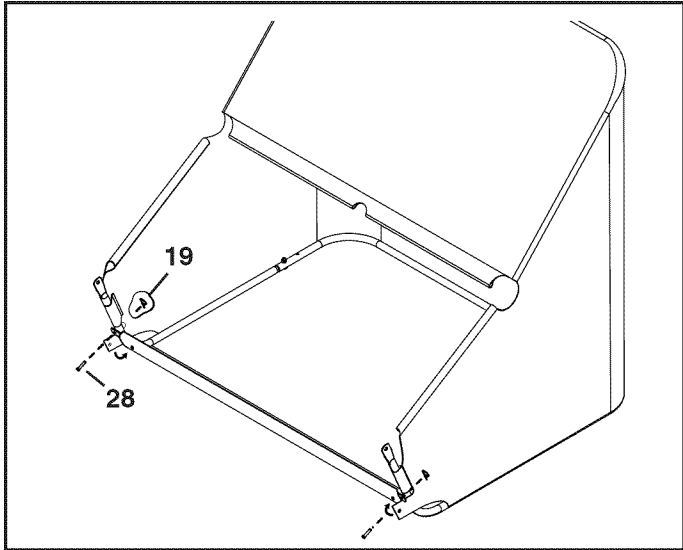

FIGURE 9

STEP 11: (SEE FIGURE 11)

- Slide the assembled tubes down through the flaps in the sides of the hopper bag (3) as shown.

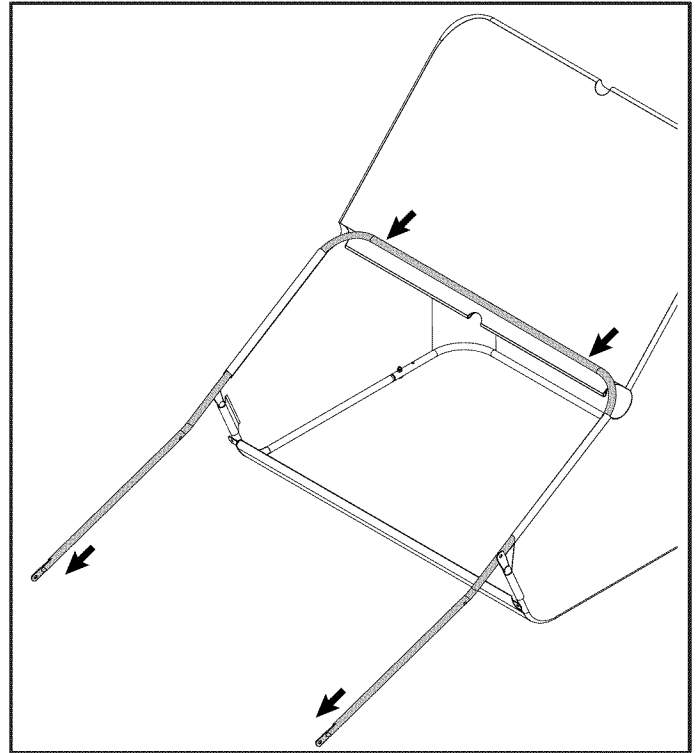

FIGURE 11

STEP 10: (SEE FIGURE 10)

- Slide a rear hopper tube (11) onto the two upper hopper tubes (6).
- Secure the upper hopper tubes (6) to the rear hopper tube (11) using two 1/4" x 1" curved head bolts (26) and 1/4" nylock nuts (24). Bolt heads should face up.

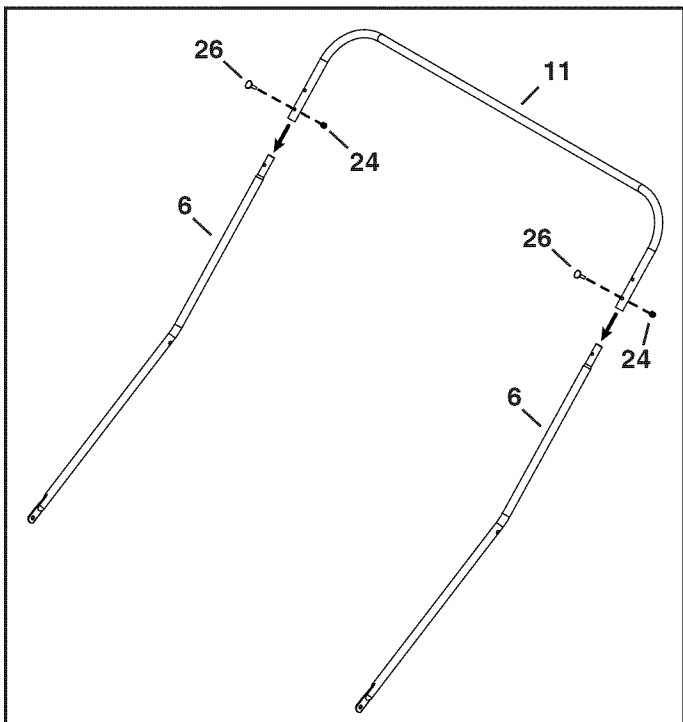

FIGURE 10

STEP 12: (SEE FIGURE 12)

- Slide the assembled tubes back up underneath the wind screen as shown.

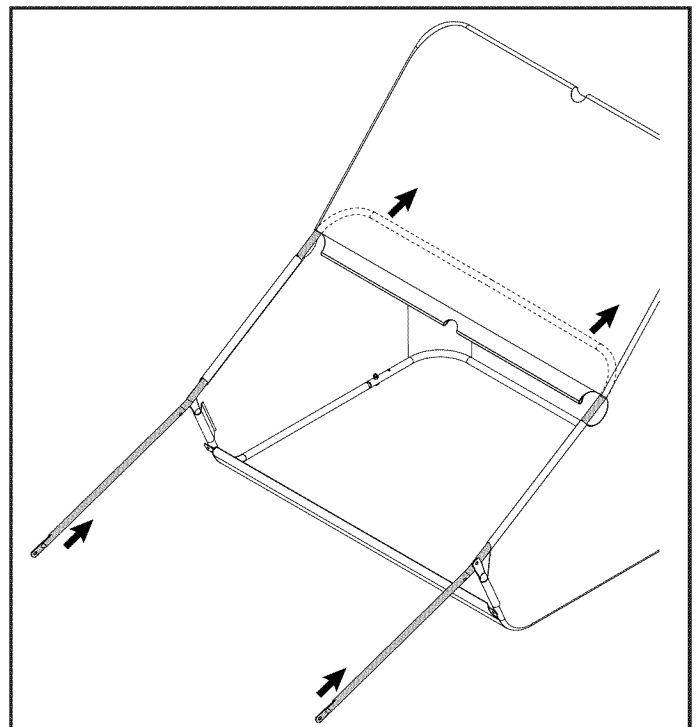

FIGURE 12

STEP 13: (SEE FIGURE 13)

1. Secure the top and bottom hopper tubes together using two 5/16" x 3/4" hex bolts (17) on inside and two 5/16" nylock nuts (21) outside.

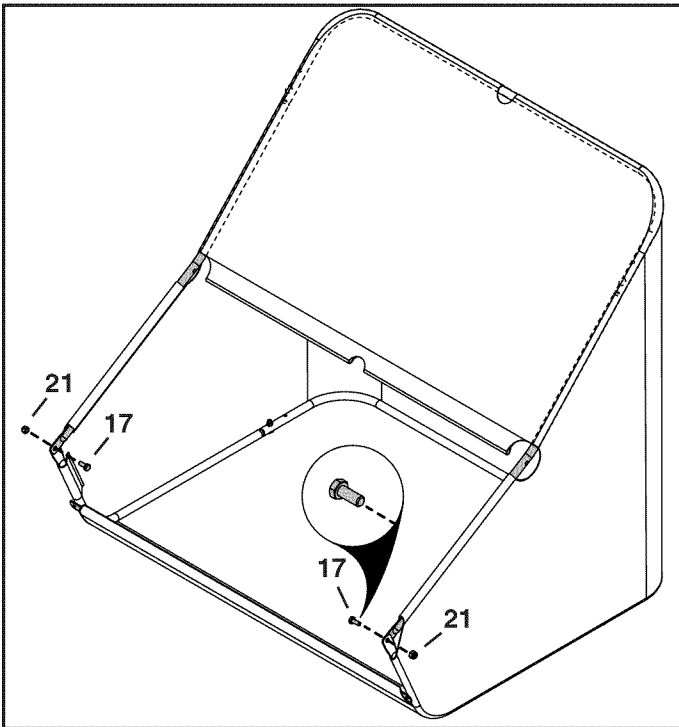

FIGURE 13

STEP 14: (SEE FIGURE 14)

- Install two cotter pins (27) in the rear hopper tube. Bend ends of cotter pins around tube.
- Slide the dump handle clip (33) onto the dump handle.
- Attach the dump tube to the rear hopper tube using a U-clamp (34) placed between the cotter pins, a 1/4" x 1-1/2" hex bolt (16) and a 1/4" nylock nut (24).
- Swivel the dump tube so that the end of the tube rests on the ground behind the bag and supports the rear of the bag in an upright position.

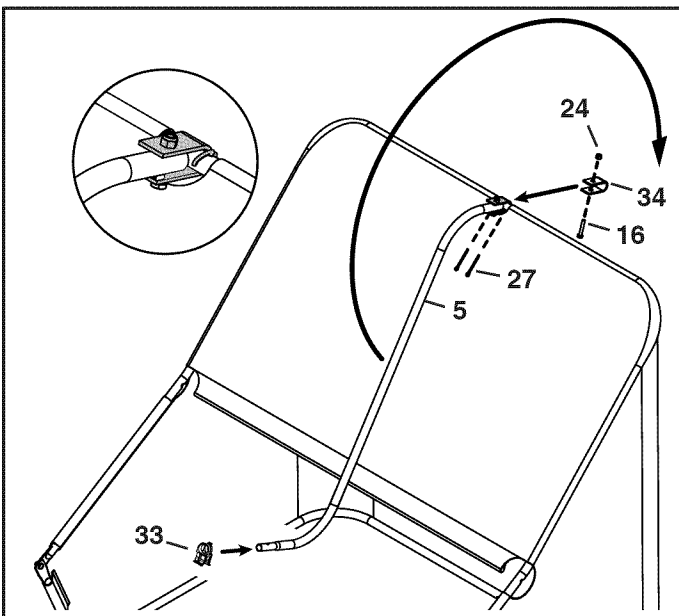

FIGURE 14

STEP 15: (SEE FIGURE 15)

- Insert the hopper support rods (7) into the hole beneath the curved head bolt (26) in each upper hopper tube. Flex and insert the rod into the hole in the bottom rear hopper tubes as shown.

NOTE: The hopper support rods will flex about as much as shown in figure 15 when they are assembled.

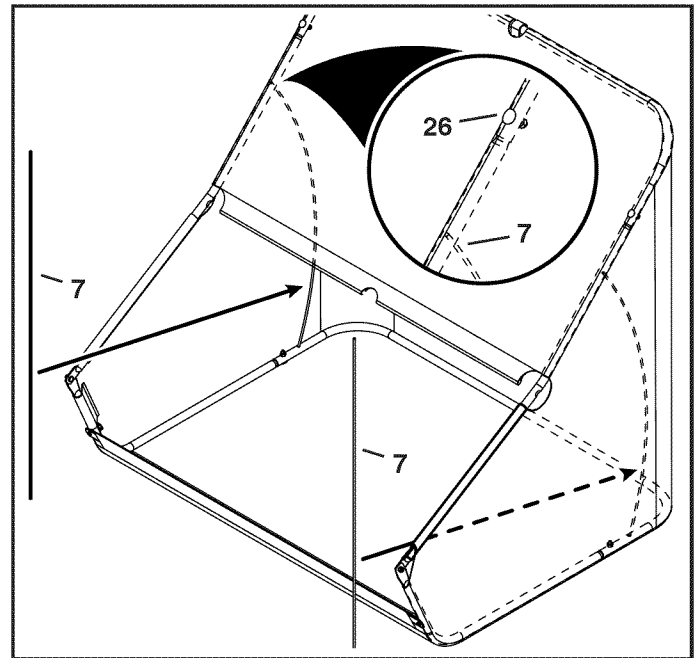

FIGURE 15

STEP 16: (SEE FIGURE 16)

- Slide the pivot rod (2) through the flap in the bag's windscreen first and then through the hole in each upper hopper tube.
- Hammer a palnut (23) onto each end of the pivot rod.

HINT: Place the bag on its side on a hard surface to make installation of palnuts easier.

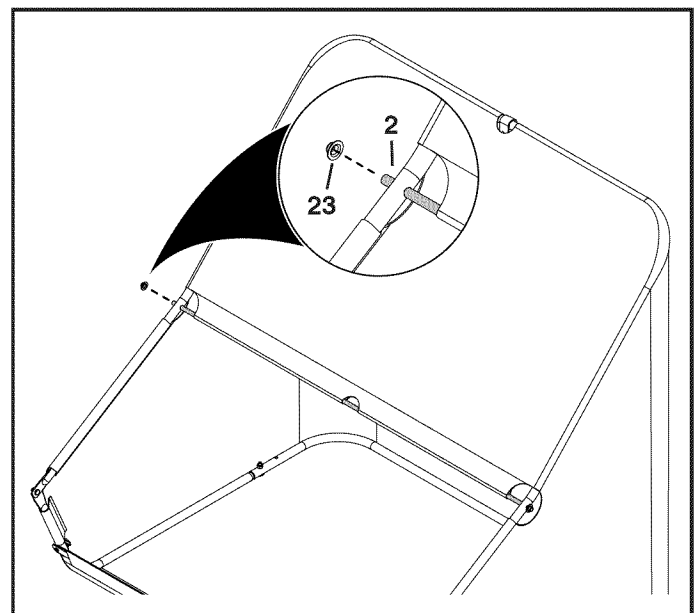

FIGURE 16

STEP 17: (SEE FIGURE 17)

- Slide the handle grip (29) onto the end of the handle tube (9).
- Assemble the handle tube (9) to the dump tube (5) and secure in place with a 1/4" x 1" curved head bolt (26) and 1/4" nylock nut (24).
- Snap the dump handle clip (33) onto the pivot rod.

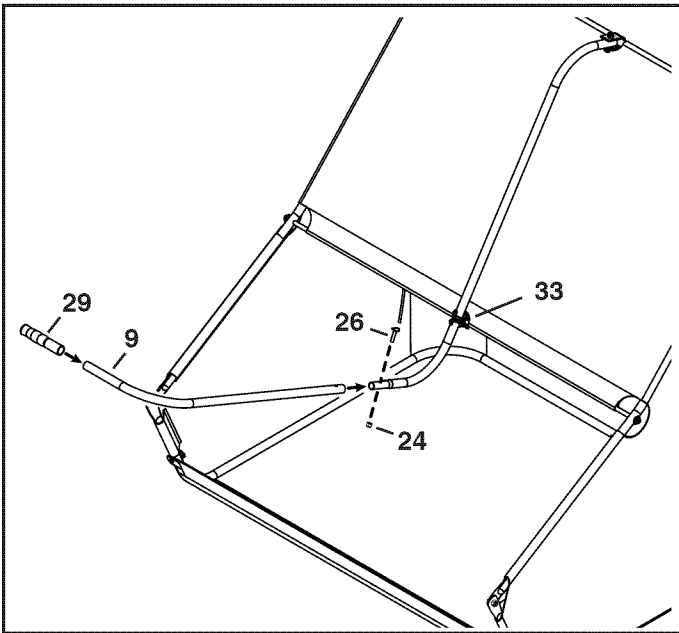

FIGURE 17

STEP 18: (SEE FIGURE 18)

- To attach the hopper bag to the sweeper, slide the pivot rod into the pivot rod retainers on the ends of the bag arm channels. The channels go on the inside of the bag tubes.

HINT: Temporarily loosen the plastic wing nuts (31) if necessary to fit the channels inside the bag.

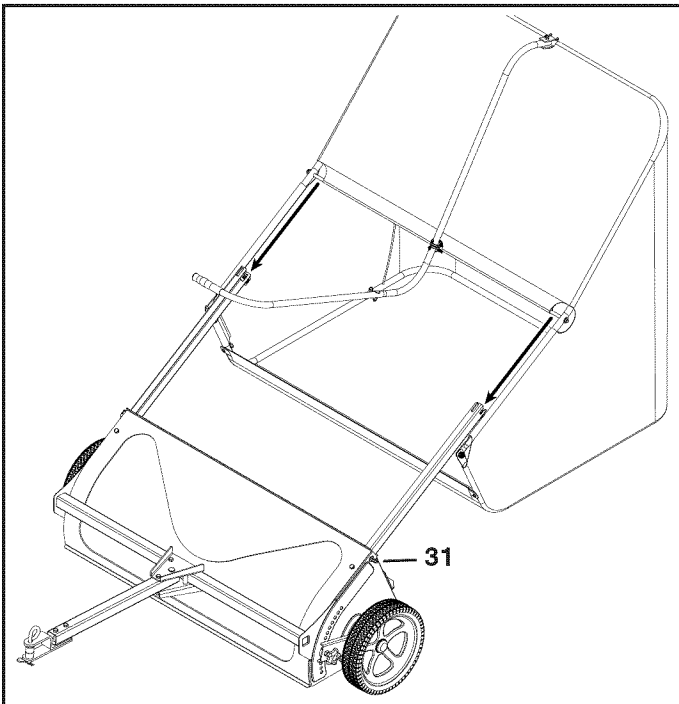

FIGURE 18

ATTACHING SWEEPER HITCH TO TRACTOR

1. Place the tractor and sweeper on a flat level surface.
2. Set the sweeper height adjustment handle to about the middle of its adjustment range.
3. Attach the sweeper hitch to the tractor hitch, making adjustments to the hitch brackets depending on the drawbar height of your tractor as shown in GROUP A, GROUP B and GROUP C diagrams in figure 20.
4. Arrange the spacers into one of the three possible combinations as shown below in the GROUP A, GROUP B and GROUP C diagrams in figure 20.

IMPORTANT: To obtain the best performance from your sweeper, arrange the spacers so that the sweeper bag is approximately level with the ground as shown in figure 19.

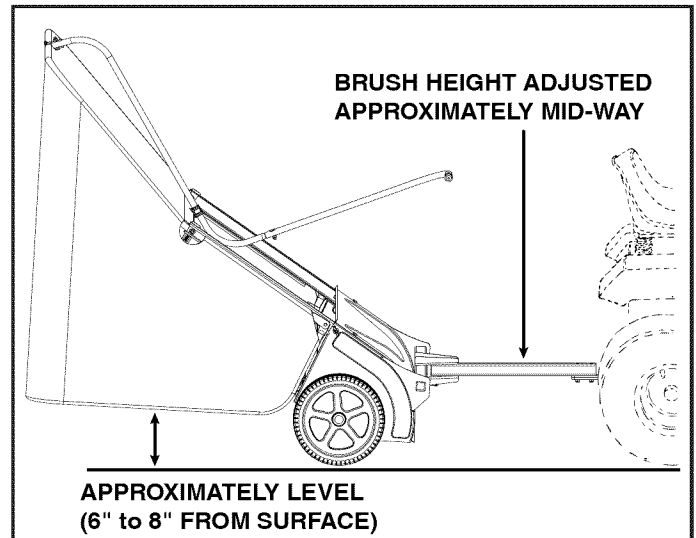

FIGURE 19

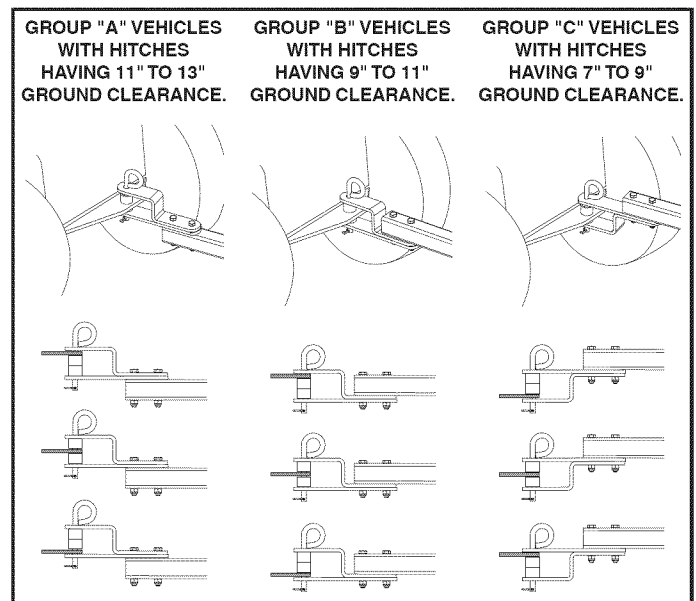
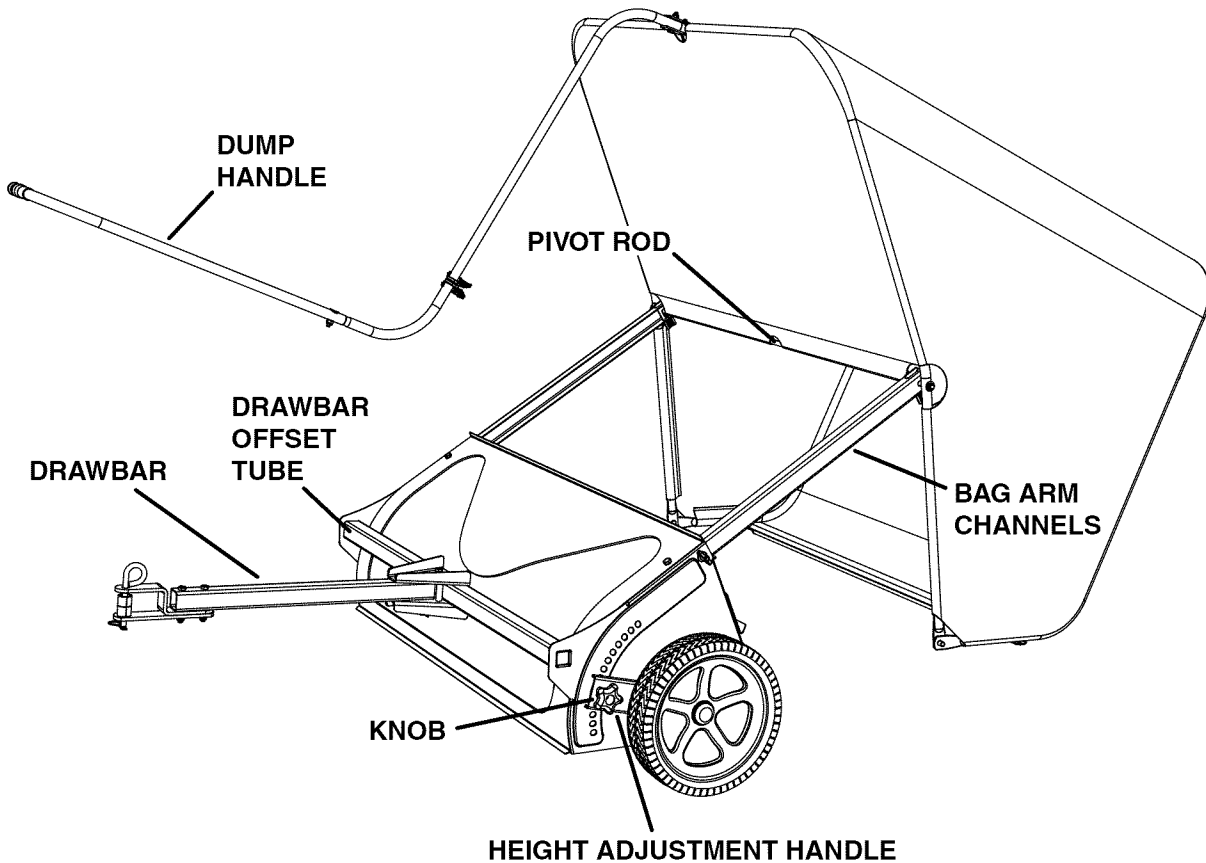

FIGURE 20

OPERATION

(SWEEPER SHOWN IN DUMP POSITION)



- | | |
|---------------------------------|---|
| Dump Lever | Permits dumping of hopper bag from driver's seat. |
| Bag Arm Channels | Connects the hopper bag to the sweeper housing. |
| Pivot Rod | Allows hopper bag to tilt forward to dump material. |
| Height Adjustment Handle | Adjusts the operating height of the sweeper. |
| Knob | Locks the height adjustment handle into a height adjustment hole. |
| Drawbar | Connects the sweeper to the towing vehicle. Adjusts for various height tractor hitches. |
| Drawbar Offset Tube | Allows drawbar to be offset from tractor. |

HOW TO USE YOUR SWEEPER



CAUTION: Maximum towing speed is 6 m.p.h. Driving too fast may cause damage to wheels and bearings.

BRUSH HEIGHT ADJUSTMENT

- To adjust sweeper brushes to best operating height, loosen adjustment knob and push down on height adjustment lever to raise the brush, or push up on the lever to lower the brush. See figure above. Best adjustment is when the brush setting is 1/2" down into the grass. Always mow the grass to an even height before sweeping.

DRAWBAR OFFSET

- The drawbar can be attached to the center, left hand or right hand set of holes in the drawbar offset tube.

SWEEPING SPEED

- Do not exceed 6 m.p.h.** Try a starting speed of approximately 3 m.p.h. (third gear on most tractors). Depending on conditions, it may be necessary to adjust the sweeping speed in order to achieve best results.

DUMPING OF SWEEPER

- Your sweeper can be dumped without getting off of the rider or tractor. Unclip dump lever from pivot rod and pull forward to empty the hopper. Always empty hopper after each use.



CAUTION: Keep sweeper away from fire. Excessive heat can damage the brushes and hopper bag and could cause the bag and its contents to burn.

MAINTENANCE

CUSTOMER RESPONSIBILITIES

Read and follow the maintenance schedule and the procedures listed in the maintenance section.

MAINTENANCE SCHEDULE Fill in dates as you complete regular service.	Service Dates											
	Before each use	After each use	Twice a year	Every season	Before storage	Every two years						
Check for loose fasteners	X											
Check for worn or damaged parts	X		X									
Lubricate brush shaft bearings		X										
Lubricate wheel bearings			X									
Clean Sweeper		X		X								
Clean/Lubricate chain and sprockets					X							

SCHEDULED MAINTENANCE

- Clean the sweeper after each use.
- Inspect for worn or damaged parts, such as brushes and wheels.
- Lubricate the brush shaft bearing twice a with a few drops of light weight oil.
- Every two years, remove wheels and clean sprockets, chains, and gears found inside the wheel housing. After cleaning, lubricate with an even coat of light grease. To remove the wheel, pop off the hub cap using a screwdriver and remove the lock nut and flat washer.

CLEANING

- Clean sweeper housing with a soft brush or cloth.
- Clean debris from hopper bag with a brush or broom.
- Remove any material which has wrapped around brushes or ends of brush shaft.

TROUBLESHOOTING

Wheels skid when sweeping	<ul style="list-style-type: none"> • Brushes set too low. • Brushes are jammed. • Wheels are jammed. 	<ul style="list-style-type: none"> • Adjust height till brushes are 1/2" down into grass. • Stop sweeper. Remove obstruction. • Remove one wheel at a time to check for obstruction or damage Refer to Service and Adjustments section.
----------------------------------	---	--

STORAGE



CAUTION: Before storing the sweeper, always empty hopper bag to avoid spontaneous combustion.

- Clean the sweeper and hopper bag thoroughly to help prevent rust and mildew.
- To collapse the hopper bag for storage, remove the two hopper support rods from the rear of the hopper.
- Remove the hitch pin (20) from the center hole, fold the drawbar to the right or left and then replace hitch pin (20). Refer to figure 5 on page 6.
- Remove plastic wing nuts (31) from bag arm channel. Fold bag arm channels into sweeper housing and replace plastic wing nuts (31). Refer to figure 3 on page 5.
- Store in a dry area.

SERVICE AND ADJUSTMENTS

BRUSH REPLACEMENT

NOTE: Replace brushes one brush at a time.

1. Remove the hopper bag from the sweeper.
2. Loosen hex bolts and lock nuts on two single brush retainers which clamp one brush to the double brush retainers. **DO NOT** loosen or remove bolts which fasten double brush retainers to brush shaft.
3. Slide the brush out of the retainers, noting on which side of the brush the bristles overlap.
4. Install new brush, making sure the bristles overlap on the same side of the brush as before.

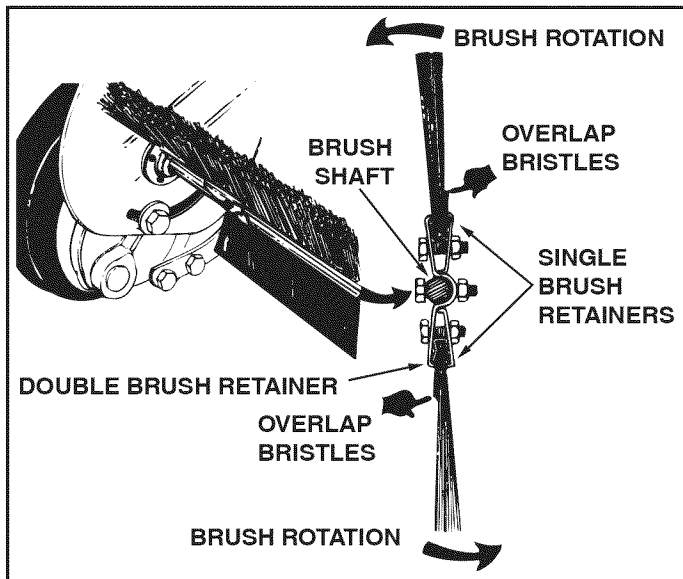

FIGURE 21

SPROCKET, CHAIN AND PAWL SERVICE

IMPORTANT: Do Not remove both wheels at the same time to avoid mixing of parts. (The R.H. and L.H. ratchet sprockets are not interchangeable.) Make notes on the position of all parts before removing them.

- Remove hub cap, nylock nut and washer on outside of wheel and then remove wheel.
- Remove the dust cover by removing the two #12 screws which fasten it to the wheel housing. (It is not necessary to remove the dust cover if you are only cleaning and lubricating the chain and sprockets.)
- Remove the retaining rings and washers which hold the sprockets onto the shafts.
- Remove the chain and both sprockets, holding them in position and sliding them off both of the shafts. (Look for the drive pin, which may fall out of the brush shaft when the ratchet sprocket is removed.) See figure 22.
- To reassemble, insert the drive pin through the hole at the end of the brush shaft. Make sure the pin slides back and forth easily in the shaft.
- Lightly grease both shafts and the chain, and fill the ratchet sprocket with grease. Assemble the chain with both sprockets back onto the shafts.
- Lightly grease the axle and then reassemble the wheel. The brushes should rotate only during forward rotation of the wheel. If the brushes are driven (rotated) by both forward and reverse rotation of the wheel, the drive pin is jamming in the ratchet gear. Disassemble and clean and lubricate the drive pin and ratchet gear.

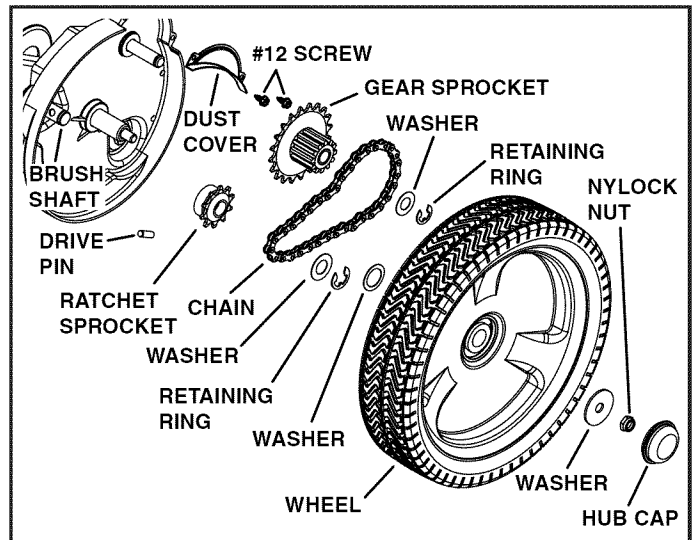
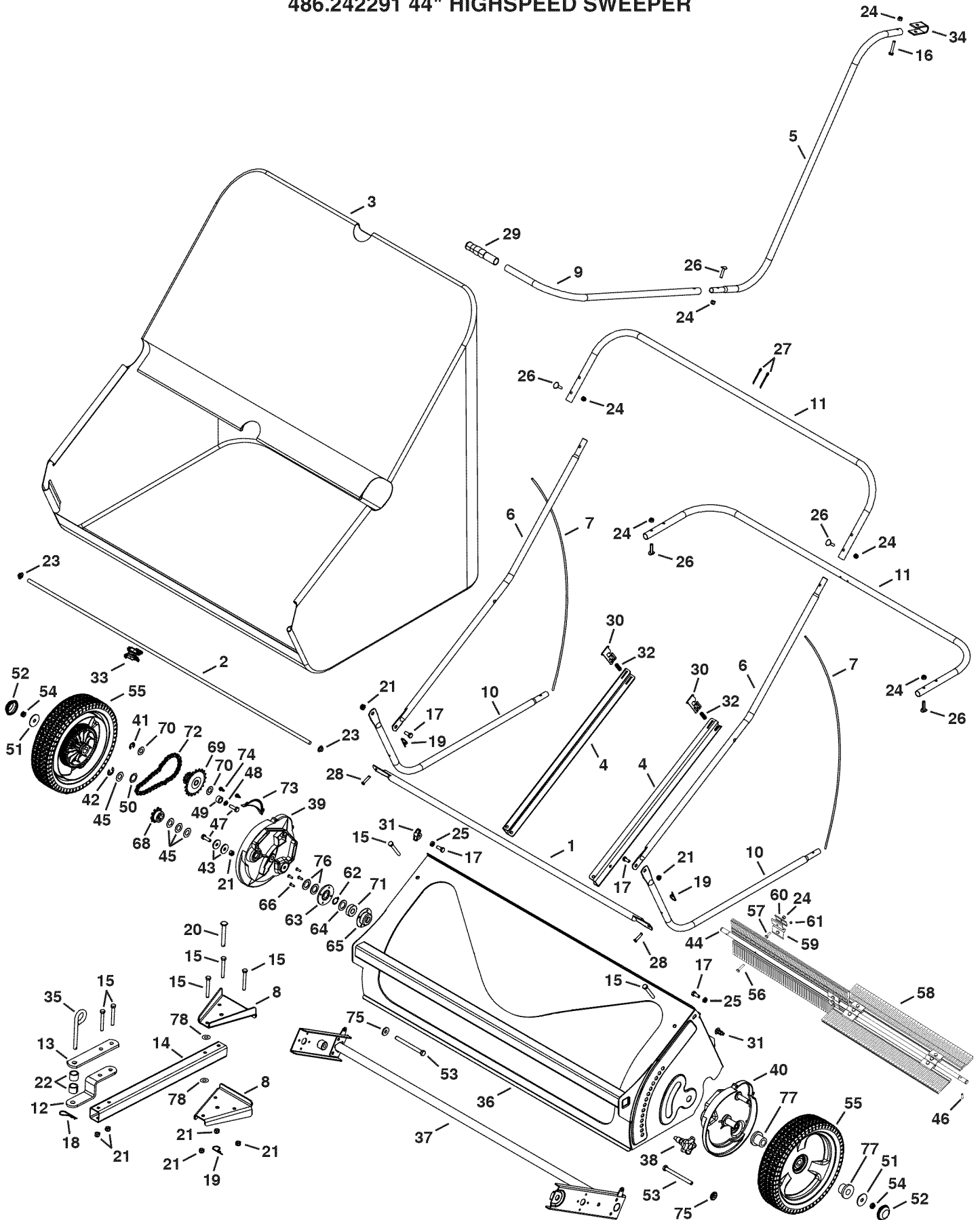

FIGURE 22

NOTES

REPAIR PARTS ILLUSTRATION

486.242291 44" HIGHSPEED SWEEPER



REPAIR PARTS LIST

486.242291 44" HIGHSPEED SWEEPER

REF	QTY	PART NO	DESCRIPTION	REF	QTY	PART NO	DESCRIPTION
1	1	42020	Bag Frame Tube	41	2	1650-1	Retaining Ring (E Type)
2	1	41041	Pivot Rod	42	2	716-0106	Retaining Ring 5/8" (E Type)
3	1	40890	Hopper Bag	43	4	736-0231	Washer, .344 x 1.125 x .12"
4	2	26414	Bag Arm Channel	44	1	25019	46" Brush Shaft
5	1	40989	Dump Tube	45	8	44007	Shim Washer
6	2	40892	Upper Hopper Tube	46	2	47046	Dowel Pin, 1/4 x 3/4"
7	2	43938	Hopper Support Rod	47	4	43063	Hex Bolt, 5/16-18 x 1"
8	2	27115	Drawbar Bracket	48	2	43086	Lock Washer, 5/16"
9	1	40894	Handle Tube	49	2	47364	Spacer, .52 x .75 x .4"
10	2	40897	Lower Hopper Tube	50	2	44008	Washer, .78 x 1.125 x .025
11	2	40893	Rear Hopper Tube	51	2	141	Washer, .378 x 1.25 x .061
12	1	23014	Hitch Bracket	52	2	41017	Hub Cap
13	1	24192	Straight Hitch Bracket	53	2	49428	Hex Bolt, 3/8-16 x 4-1/4"
14	1	26413	Drawbar	54	2	42210	Nylock Jam Nut, 3/8-16
15	7	44292	Hex Bolt, 5/16-18 x 2-1/2"	55	2	41074	Wheel
16	1	43648	Hex Bolt, 1/4-20 x 1-1/2"	56	4	49954	Socket Screw, #10-32 x 1"
17	4	43182	Hex Bolt, 5/16-18 x 3/4"	57	8	43012	Hex Bolt, 1/4-20 x 3/4"
18	1	43343	Hair Cotter Pin, 3/32 x 2-5/16"	58	4	46780	42" Sweeper Brush
19	3	43055	Hair Pin, 3/32 x 1.8"	59	4	23580	Brush Retainer (Double)
20	1	47623	Hitch Pin, 3/8 x 3"	60	8	23581	Brush Retainer (Single)
21	9	47810	Nylock Nut, 5/16-18	61	4	47171	Nylock Nut, #10-32
22	2	23368	Spacer, .76 x 1 x .76"	62	2	43655	Retaining Ring, 3/4"
23	2	44917	Palnut, 3/8"	63	2	62489	Brush Bushing Assembly
24	14	47189	Nylock Nut, 1/4"	64	2	1540-31	Washer, .78 x 1.25 x .062
25	2	712-3046	Jam Nut, 5/16-18	65	2	1629-56	Bearing Retainer
26	5	43978	Curved Head Bolt, 1/4-20 x 1"	66	8	C-9M5732	Pop Rivet
27	2	43093	Cotter Pin, 1/8 x 1-1/2"	67	1	43889	Ratchet Sprocket (LH) (not shown)
28	2	48365	Clevis Pin, 1/4 x 1.11"	68	1	43890	Ratchet Sprocket (RH)
29	1	7071	Handle Grip 3/4"	69	2	62490	Gear Sprocket Assembly
30	2	26484	Rod Retainer	70	4	44137	Washer, .518 x 1 x .02
31	2	712-0421	Plastic Wing Nut, 5/16"	71	2	44232	Ball Bearing
32	2	41036	Compression Spring	72	2	44542	Roller Chain
33	1	41013	Dump Handle Clip	73	2	23573	Dust Cover
34	1	23878	U-Clamp	74	4	49102	#12 Screw
35	1	23353	Hitch Pin, 3/8 x 3"	75	2	26538	Step Spacer, .41 x .75"
36	1	67193	Sweeper Housing	76	4	1540-32	Washer, .78 x 1.25 x .015
37	1	66413	Height Adjustment Tube	77	4	45088	Wheel Bearing
38	1	40891	Height Adjustment Knob	78	2	47605	Washer, 411 x 1 x .03"
39	1	66656	Wheel Housing (RH)		1	41502	Owners Manual
40	1	66657	Wheel Housing (LH)				

Get it fixed, at your home or ours!

Your Home

For expert troubleshooting and home solutions advice:

manage my home

www.managemyhome.com

For repair – **in your home** – of **all** major brand appliances, lawn and garden equipment, or heating and cooling systems, **no matter who made it, no matter who sold it!**

For the replacement parts, accessories and owner's manuals that you need to do-it-yourself.

For Sears professional installation of home appliances and items like garage door openers and water heaters.

1-800-4-MY-HOME[®] (1-800-469-4663)

Call anytime, day or night (U.S.A. and Canada)

www.sears.com www.sears.ca

Our Home

For repair of carry-in items like vacuums, lawn equipment, and electronics, call anytime for the location of your nearest

Sears Parts & Repair Service Center

1-800-488-1222 (U.S.A.) **1-800-469-4663** (Canada)

www.sears.com www.sears.ca

To purchase a protection agreement on a product serviced by Sears:

1-800-827-6655 (U.S.A.) **1-800-361-6665** (Canada)

Para pedir servicio de reparación a domicilio, y para ordenar piezas:

1-888-SU-HOGAR[®]

(1-888-784-6427)

Au Canada pour service en français:

1-800-LE-FOYER^{MC}

(1-800-533-6937)

www.sears.ca

Sears