

Owner's Manual

6500 Watt Diesel Generator



WARNING! To Reduce The Risk Of Injury, User Must Read And Understand Instruction Manual.

SP-GD650E

FOR SERVICE CALL: 888-896-6881
PARA SERVICIO LLAME: 888-896-6881

www.steele-products.com

Preface

This manual will instruct you in the proper operation and service of your diesel generator. Please read this manual prior to using the generator to ensure safe and proper operation. At all times, follow the instructions to keep the generator in the best working condition and to extend its life. Should you have any comments or problems, please visit your nearest Steele® location or call 1-888-896-6881.

Please pay particular attention to the warning and caution indicators both within this manual and on the unit itself.



A warning label indicates that severe personal injury or even death may occur if you do not follow the instructions



A caution label indicates that either serious personal injury or equipment damage may result if instructions are not followed.

This diesel generator will perform safely and to specification if operated according to the following instructions. Failure to do so may result in serious personal injury and/or equipment damage.

Warning:

1. Prevent the threat of fire

- **Never** add fuel while the engine is running.
- Wipe off any spilled fuel with a clean cloth before starting.
- Keep all explosive and flammable items safely away from the generator.
- **Maintain adequate ventilation** with **at least** three feet of clear space on all sides of the generator from buildings and other pieces of equipment.
- **NEVER** operate this unit in a closed room or garage.
- Only operate the generator on a level surface
- Do not store the generator indoors while the engine is still hot.

2. Prevent Inhalation of Exhaust Fumes

- Carbon Monoxide is an odorless gas that can **kill you!**
- **Do not** operate this generator in a confined space where the exhaust cannot escape. This means:
 - **Do not** use this unit indoors.
 - **Do not** use this unit in a closed garage.
 - **Do not** attempt to vent the exhaust of this unit outdoors while using the unit indoors.
- Should you experience a headache, ringing in your ears or begin to feel drowsy, **immediately** get some fresh air away from the generator.



3. Prevent being burned

- The muffler and engine body of this generator get very hot when the engine is operating or shortly thereafter. **Do Not Touch** these parts or you may be severely burned.

4. Prevent Electrical Shocks and Short Circuits

- To avoid electrical shocks or short circuits, **do not**:
 - Touch the unit with wet hands
 - Stand in water
 - Operate in the rain or place the unit in standing water

- **Note:** This generator is **not** waterproof and therefore should **not** be placed in rain, snow, standing water or any area where there could be water spray. Operating a unit in these environments may cause electrical short circuits that can cause electrical shocks.
- **This generator should also be grounded** to prevent electrical shocks from faulty appliances. To ground this unit, simply connect a length of heavy copper wire between the unit and a ground source.
- **Do Not** plug in any power cord until **after** the unit is operating. If equipment is attached when starting the generator, it may cause the unit to move resulting in potential injury.

Caution

- Most appliances require more power to start than their rated wattage. Therefore make certain that you do not overload the generator with too many appliances.
- Do not exceed the current limit of any of the electrical outlets on the generator.
- **Do not** connect the generator to a household circuit. This may cause damage to the generator and also to the wiring in your house, as well as the electrical appliances.

5. Batteries:

- Batteries contain sulfuric acid which can burn your eyes and skin. Whenever working with a battery, protect your eyes and skin from exposure to the acid. In case of contact with any acid, act **immediately** by thoroughly flushing the affected area with clean cold water and seek **prompt medical attention**.
- Batteries also generate hydrogen gas which can be extremely explosive. **Do not** smoke or allow flames near a battery, especially while in a charging mode. **Always** charge batteries in a fully ventilated area.

DANGER

CARBON MONOXIDE

Using a generator indoors WILL KILL YOU IN MINUTES.

Generator exhaust contains high levels of carbon monoxide (CO), a poisonous gas you cannot see or smell. If you can smell the generator exhaust, you are breathing CO. But even if you cannot smell the exhaust, you could be breathing CO.

- NEVER use a generator inside homes, garages, crawlspaces, or other partly enclosed areas. Deadly levels of carbon monoxide can build up in these areas. Using a fan or opening windows and doors does NOT supply enough fresh air.
- ONLY use a generator outdoors and far away from open windows, doors, and vents. These openings can pull in generator exhaust.

Even when you use a generator correctly, CO may leak into the home. ALWAYS use a battery-powered or battery-backup CO alarm in the home.

If you start to feel sick, dizzy, or weak after the generator has been running, move to fresh air RIGHT AWAY. See a doctor. You could have carbon monoxide poisoning.

Contents

1. Technical Specifications and Data.....	1
2. Configurations	2
3. Before Starting Your Generator	4
4. Starting the Generator	8
5. Operating Your Generator.....	9
6. Your Generators Capacity.....	10
7. Stopping Your Generator	14
8. Periodic Maintenance and Testing	15
9. Long-Term Storage.....	19
10. Troubleshooting & Solutions	20
11. Parts Diagram	21
12. Limited Warranty.....	32

1. Techcial Specifications and Data

Model	SP-GD650E
Rated frequency	60 Hz
Rated voltage	240V / 120V
Rated current	21A / 42A
Rated output power	5,000 watts
Max output power	6,500 watts
Rated rotation speed	3,600 RPM
Phase number	Single
Pole number	1
Excitation transistorized	Self-excitation constant voltage (AVR)
Panel type	T: General panel TA: Digital control panel
Structure type	Silent type
Fuel tank capacity	4 Gal
Fuel consumption	360 g/kw.h
Continuous running time	9 1/2 hours at 1/2 load
Starter system	Electric starter
Fuel type	Diesel
Engine model	TD186
Engine type	Single cylinder, 4-stroke, air-cooled, vertical, diesel engine
Borexstroke	86 mm x 72 mm
Displacement	0.418cm ³
Compression ratio	19:1
Rotation direction (from the flywheel)	clockwise
The lowest fuel consumption(g/kw.h)	3,600 RPM:281

2. Configurations

2.1 Parts name

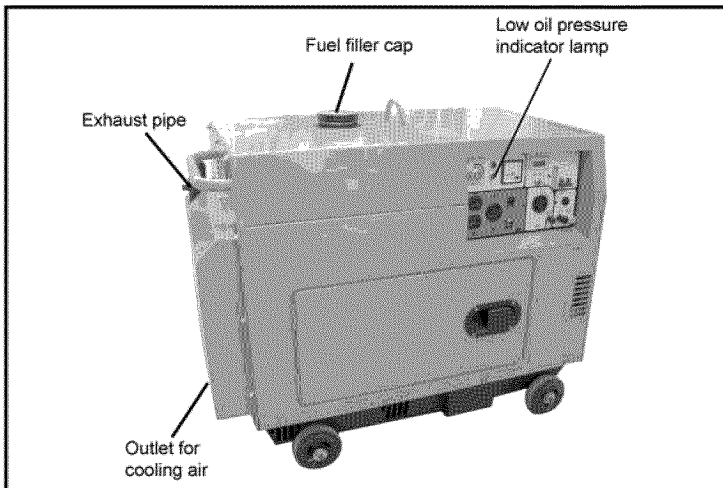
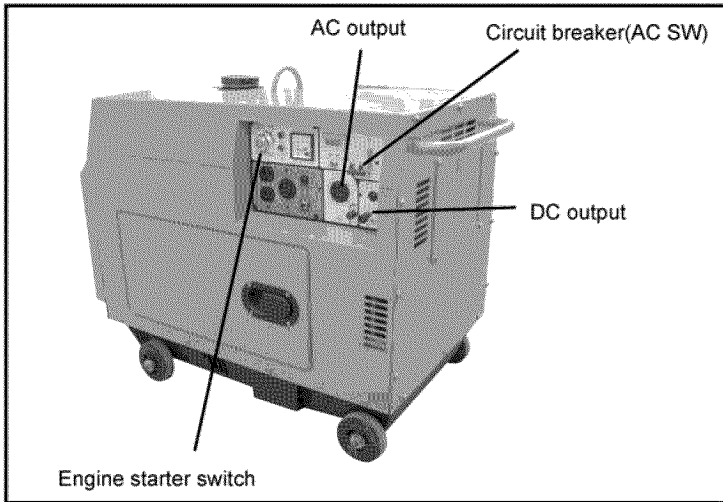

2.2 Control panel

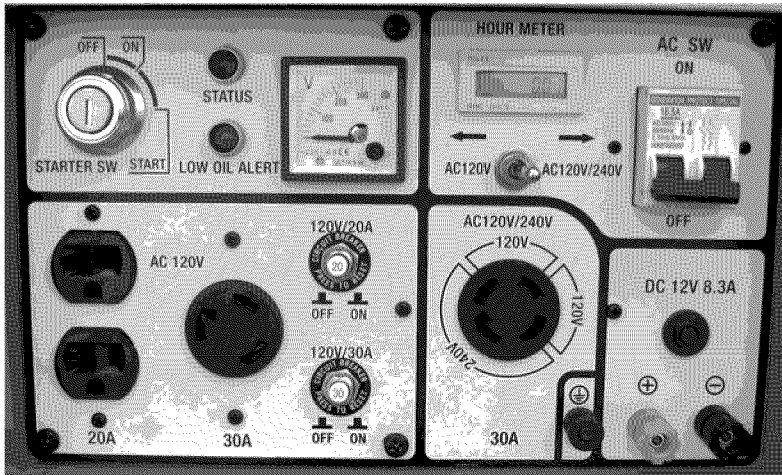

3. Before Starting Your Generator

3.1 Selection and handling of diesel fuel

- Only use light diesel fuel
- Keep dust and water out of the fuel. Failure to do so will create problems with the injection pump and nozzles.
- **Do not** overfill the tank beyond the red plug inside the fuel oil filter. Doing so can be very dangerous.

Warning:

- Refuel in a well-ventilated area with the engine **off**.
- Do not smoke or allow open flames or sparks near where you are refueling or where the fuel is stored.
- Do not overfill the tank. Make sure that the fuel cap is securely tightened after refueling.
- Do not spill any fuel. If fuel is spilled, make certain that the spilled fuel is removed **before** starting the engine.

3.2 Check and refill engine oil

Warning:

- Before every start, make sure that your generator is on a leveled surface and then check the oil level.
- The engine may be damaged if it is operated with insufficient oil.
- Too much oil may cause a sudden increase in engine speed also damaging your generator.

Caution: Your diesel generator is equipped with a "low oil" warning system. This system automatically stops the engine when the oil level becomes dangerously low, preventing major damage to your generator. **Do not** rely totally on this system for maintaining proper oil levels, as it only represents an emergency situation and not a method for checking your generator's oil level.

▪ Oil Selection

It is very important that you select the proper engine oil to maintain the life and performance of your generator. If inferior or the wrong weight oil is used, or if your engine oil is not replaced periodically, there is a risk of major damage to your engine due to overheating.

Choose the applicable viscosity according to your local temperature.

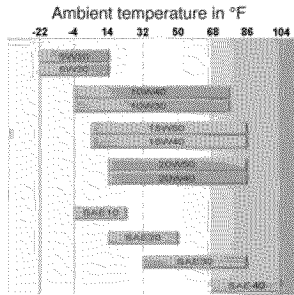

When adding oil for the first time add no more than one to one and a half quarts of oil. If the low oil light comes on, add about another quart of oil to the unit.

3.3 Servicing the air filter

1. Remove the wing nut from the air filter cap and then the cover itself. This will allow you to remove the filter.

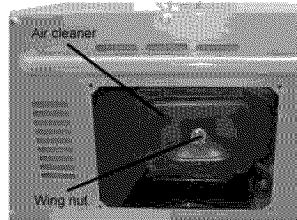

Caution:

- Do not wash the filter with detergent.
- Replace the air filter when it impedes the flow of air and cannot be completely cleaned. One indicator is when the engine exhaust changes color.
- Never operate the generator without the air filter.



2. Reattach the air filter cover and tighten the wing nut.

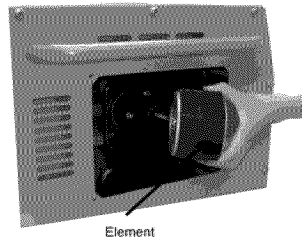

3.4 Checking the Generator

1. Make sure that you turn off the main switch and any other electrical load before inspecting the generator.

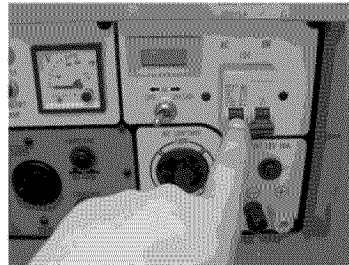

Warning:

- Turn off the main switch before starting
 - The generator must be grounded to prevent electric shock.
2. Operating dual voltage generators.
 - Make sure that you use the correct outlet for the rated voltage of the device being powered.

Caution:

- The main switch must be in the "on" position during operation.
- Before starting the engine, **unplug the devices** to be powered or make sure that all of the devices are turned "off". *If the switches for the devices are left in the "on" position and the generator is started the sudden surge in power can be very dangerous.*

3.5 How to open the cabinet door and remove the protective covers on the generator.

1. Always open the generator cabinet door and inspect the engine prior to starting the generator. To do this, simply turn the lever counterclockwise and raise the door.
2. Loosen the wing nut on the air cleaner and inspect the cleaner.
3. Open the wing nut on the cover and inspect the nozzle cover.

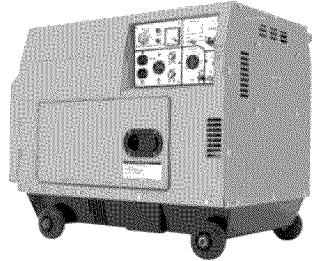

3.6 Breaking in your new generator

The first 20 hours of operation are required to properly seat your generator's operating parts. During this period, the following steps **must** be taken:

- During the initial operation, run the generator at a low speed with nothing plugged in for a minimum of **five minutes**.
- Avoid applying any heavy demands to the unit during the break-in period. Matrix recommends that the engine be operated at 3,000 RPM with no more than a 50% load for the first 20 hours of operation.
- Change the lube oil after 20 hours of initial operation or at the end of the first month, then every three months or 100 hours thereafter

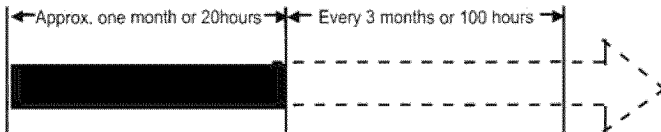

4. Starting the Generator

Warning: Do not plug in any tools or devices prior to starting your generator.

4.1 Electric Starting

1. Starting (The preparations for electric starting are the same as recoil starting)

- Open the fuel valve

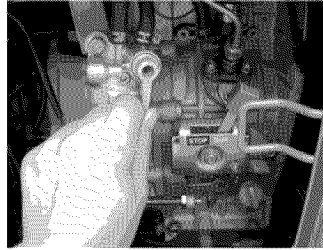

- Set the engine starter lever to the "RUN" position.

Engine starter lever

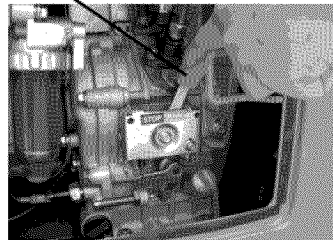

- Turn the ignition key clockwise to the "START" position and remove your hand from the key as soon as the engine starts. If the engine does not start in 10 seconds just wait 15 seconds and repeat the process.

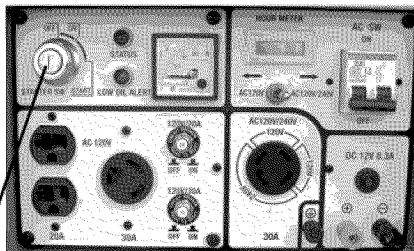

Engine starter key

2. Battery: If the battery has an open cell design, check the water level every month. If it is low, refill using distilled water until the cell is full. If the battery is a sealed unit, check for cracks and leaks.

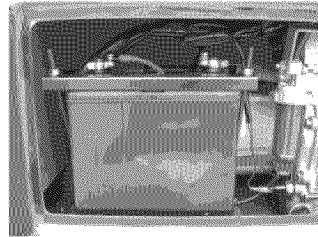

Caution

If the distilled water level is too low, the engine may fail to start because there isn't sufficient battery power. If the water level is too high, the fluid will corrode surrounding parts shortening the life of the battery. Always maintain the level of distilled water at the recommended level. **Never** use well or tap water as the minerals in the water will destroy your battery.

5. Operating Your Generator

1. Before plugging anything into the generator, let your generator run for a minimum of three minutes at normal speed.

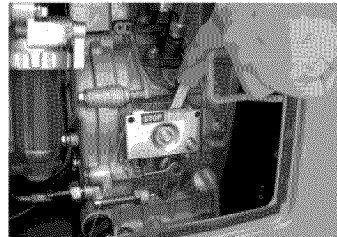

2. If your generator has a "low oil" light, check to make certain that it is not illuminated.

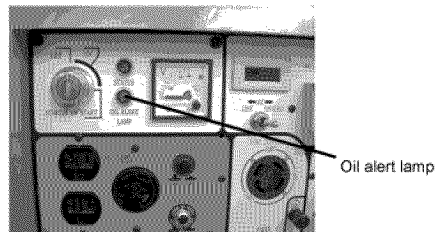

Caution

- The low oil warning light is activated by either a low pressure level or an inadequate amount of oil in the reservoir. When the low oil light is activated,

the engine will automatically stop. If you attempt to start the generator without addressing the problem, the unit will not start. When the "low oil" light illuminates, check the oil level first to make certain that there is adequate oil in the reservoir.

- **Do not** adjust either the engine governor bolt that controls engine speed or the fuel injection bolt that controls fuel mix. Doing so will affect the overall performance of your generator.

5.2 Operational System Checks

- Determine whether there is abnormal sound or vibration
- Determine whether the engine misfires or runs rough.
- Examine the color of the exhaust. If it is too black or too white, shut off your generator.

Caution:

- If your generator has been in operation, the muffler will be extremely hot. **Do Not** touch the muffler as you can be severely burned.
- Never refill the fuel tank while the engine is running.

6. Your Generators Capacity

Caution

- Do not attempt to start two or more devices simultaneously. First plug in or start one device, then the next, and then the next.

6.1 AC application

- Make certain that you operate the generator at its rated speed in RPM's. If this is not done, the AVR or *Automatic Voltage Regulator* will incorrectly produce too much voltage shortening the life of the AVR.
- After switching on the circuit breaker, check the voltmeter on the control panel. The voltmeter should point to 120V +/- 5% for a single phase generator and 230V +/- 5% (50 Hz) for a multiphase generator.

- When the dual voltage generator exceeds or is below these levels, then the circuit breaker should be in the "OFF" position. If not both the generator and the devices powered by it can be damaged.
- Always connect devices to the generator with the highest demand device first and then the lesser demand devices afterward. If the operation becomes overloaded, the generator engine will lag or stop suddenly. If this happens, unplug all devices immediately, turn off the main switch on the generator and check all systems.
- Three phase generators
 - Make certain that you balance all three phases during operation. Stop the engine and check to see if the generating is operating within 20% of specification. If the engine is not, reduce your load or turn off the generator.
 - The sum of the load for each phase must be below the overall rated load. In addition, the overall current drawn must be less than the overall rated current.
 - The phase arrangement A, B, C, D (or U, V, W, N) should be from left-to-right or clockwise.
 - If you are attempting to start three non-synchronous motors, always start with the heaviest duty motor first and then progress to the lighter duty units.

Note: If overloading the circuit trips the circuit breaker, reduce the electrical load on the circuit and then wait a few minutes before resuming operation.

6.2 DC application

1. The DC terminals are only for charging the 12V battery included with your generator.
2. Set the circuit breaker in the "OFF" position while charging the battery. On the 12V output terminals, a charge switch can be installed so that the unit can be turned on and off as desired.
3. If your generator has an automatic battery with separate leads, make certain that you disconnect the negative lead while you are charging the battery.









Caution

- Identify and connect positive-to-positive and negative-to-negative poles from the battery to the engine. Crossing the wires will destroy both the battery and the electrical components of your generator.
- If you attempt to use a larger battery than recommended you will create excessive current that will blow the fuse in the generator.
- **Do not** attempt to operate the generator while it is still connected to the battery.
- **Do not** use a 12V DC and AC current at the same time.

Caution

- All lead batteries emit explosive gas when being charged. Keep sparks, flames and cigarettes away from the battery while charging. To prevent sparks, always connect the booster cables to the battery first and then to the generator. When the battery is charged, disconnect the cables from the generator first.
- Charge the battery in a well ventilated place.
- Unless the battery is sealed, remove the caps from each cell before charging.
Stop charging if the battery feels extremely hot. If the temperature exceeds 45C or 113F then the battery is too hot.

6.3 All electrical appliances, particularly motor driven equipment, have extremely highly levels of current draw during their start-up period. The table below provides a quick reference regarding connecting different types of devices to the generator.

TYPE	WATTAGE		TYPICAL APPLIANCE	EXAMPLE		
	STARTING	RATED		APPLIANCE	STARTING	RATED
<ul style="list-style-type: none"> • Incandescent lamp • Heating appliance 	X1	X1	 Incandescent lamp TV 	 Incandescent lamp 100W	100VA (W)	100VA (W)
<ul style="list-style-type: none"> • Fluorescent lamp 	X2	X1.5	 Fluorescent lamp	 40W Fluorescent lamp	80VA (W)	60VA (W)
<ul style="list-style-type: none"> • Motor-driven equipment 	X3~5	X2	 Refrigerator  Electric fan	 Refrigerator 150W	450-750VA (W)	300VA

7. Stopping Your Generator

Step I: Disconnect all electrical plugs from the generator outlets **before turning off the generator!**

Step II: Turn off the circuit breaker on the generator.

Step III: Set the starter level in the “run” position, operating the generator for about three minutes with nothing plugged in. **Note: Do Not stop the generator without this step, as the operating temperature of the engine will increase thereby damaging the unit.**



Step IV: Depress the “stop” lever

Step V: If the unit has an recoil starter, turn the key to the “off” position.

1. Move the fuel lever to the “Stop” position.

Step VI: Retract the recoil starter handle until you feel resistance. (At this point both the intake and exhaust valves are closed). Leave the handle in the position as it prevents damp air from entering the engine and thereby prevents rust from forming.

Warning:

- Should the engine continue to operate when the starter lever is placed in the “Stop” position, either turn the fuel valve to the “Close” position or loosen the nut of the high pressure fuel pipe on the pump side of the engine. If you do this, remember to tighten it again before attempting to start the engine.
- **Do not** attempt to stop the engine with the decompression lever.
- **Always** make certain that all electrical plugs are removed from the generator outlets before turning off your generator.

8. Periodic Maintenance and Testing

Periodic inspections and service are very important for maintaining your generator's engine in proper working order. The following chart indicates your inspection and service frequency. Please keep this chart handy and refer to it as needed.

Warning:

- Turn off the engine before performing any service. If the engine must be in operation, only do so in a well ventilated area as the exhaust contains carbon monoxide which can be fatal.
- After the generator has been operated, remove all dirt and sediments from the outside cover to prevent corrosion.

Item	Intervals	Every day	First month or 20 Hrs	Third month or 100 Hrs	sixth month or 500 Hrs	Every year or 1000 Hrs
Check and refill fuel oil		○				
Drain out fuel oil			○			
Check and refill engine oil		○				
Check for oil leakage		○				
Check and tighten fastening parts		○			● Tighten the cylinder head bolts	
Replace engine oil			○ (First time)	○ (Second time)		
Clean engine oil filter					○ (Replace if necessary)	
Replace air cleaner element		(Service more frequently when used in dusty areas)			○ (Replace)	
Clean fuel oil filter					○	● (Replace)
Check fuel injection pump					●	
Check nozzle					●	
Check fuel pipe					● (Replace if necessary)	
Adjust clearance of intake/exhaust valves			● (First time)		●	
Grind intake/exhaust valves						●
Replace piston ring						●
Check battery electrolyte	Every month					
Check carbon brush and slip ring					●	
Check insulation resistance	The generating set has been stored more than 10days ○					

Note: "○" indicates that special tools are required, please contact with agent.

8.1 Replacing the Engine Oil

1. Operate the engine for two to three minutes without **allowing the engine to get hot**.
2. Turn off the engine
3. *While the engine is still warm*, remove the oil filter cap and the drain plug located on the bottom of the cylinder block, allowing the old oil to drain. Insert the drain plug, refill with recommended oil and place the oil filter cap back on the engine. *Remember to recycle your oil as it is a major cause of soil pollution.*

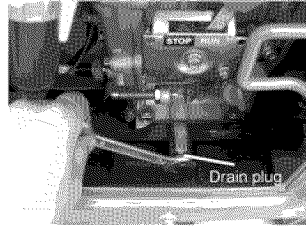

8.2 Cleaning the engine oil filter

Clean the engine oil filter every six months or 500 hours, whichever comes first. Replace if necessary.



8.3 Replacing the air cleaner

Do not clean the air cleaner with detergent. Replace the unit every six months or 500 hours, whichever comes first.

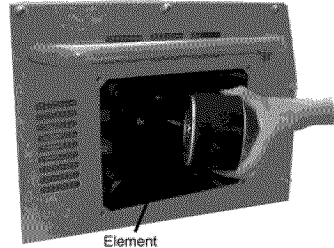

Caution: Never operate the engine without the air cleaner or with a defective cleaner as it can damage the interior of your engine and shorten its life.

8.4 Cleaning and replacing the fuel oil filter

The fuel oil filter also requires periodic cleaning to insure maximum engine performance.

Cleaning: Every six months or 500 hours

Replacement: Every year or 1000 hours

1. Turn the fuel valve to "OFF" position.

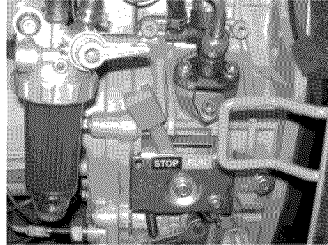

2. Remove the small screw from the fuel valve, removing the fuel filter from its port.
3. Wash the filter thoroughly with diesel fuel.
4. Replace the filter and all parts to their original position.

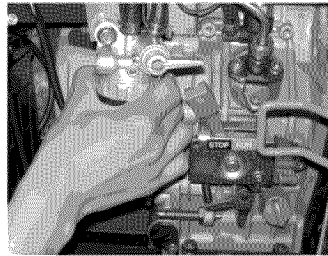

8.5 Tightening the Cylinder Head Bolt

Tightening the cylinder head requires a special tool. **Do Not** attempt this yourself! Contact an authorized service centre.

8.6 Checking the injection nozzle and fuel injection pump requires an authorized service centre where they will:

1. Adjust the clearance for the intake/exhaust valves.
2. Grind the intake and exhaust valves
3. Replace the piston ring

Warning: Do not perform the injection nozzle test near an open flame as the fuel may ignite. Do not expose bare skin to the fuel as it may cause injury. **Always** keep away from the nozzle.

8.7 Checking refilling and charging the battery

Your diesel generator uses a 12V battery for starting. Through use, the battery may naturally lose some of its charge along with the distilled water inside. Before starting your generator, periodically check for physical damage to the battery and also the fluid levels. If the battery is damaged, replace it. If the

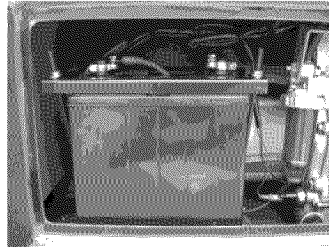

fluid levels are low, fill each cell with distilled water as needed. Never use well or tap water as they contain minerals that will harm your battery and shorten its life.

Warning:

- Batteries contain sulfuric acid which can burn your eyes and skin. Whenever working with a battery, protect your eyes and skin from exposure to the acid. In case of contact with any acid **immediately** thoroughly flush the affected area with clean cold water and seek **prompt medical attention**.
- Batteries also generate hydrogen gas which can be extremely explosive. **Do not** smoke or allow flames near a battery, especially while in a charging mode. **Always** charge batteries in a fully ventilated area.

8.8 Inspecting the carbon brush and slip ring. Periodically, check the generators carbon brush and slip ring and readjust if there is a spark.

9. Long-Term Storage

If your plan on storing your generator for periods of time exceeding one month, please follow these guidelines:

1. Operate the engine for two to three minutes. **Do not allow the engine to get hot.**
2. Turn off the engine
3. **While the engine is still warm**, drain the crankcase oil by opening the oil drain plug.
4. When all oil has drained, replace the plug and refill the oil reservoir with clean oil.
5. Drain off the fuel from the fuel tank: Turn the fuel valve to 'OFF' position, remove the fuel filter, and then turn the fuel valve to the 'ON' position to drain the fuel.

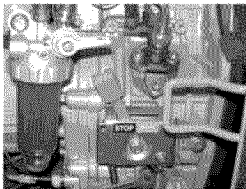
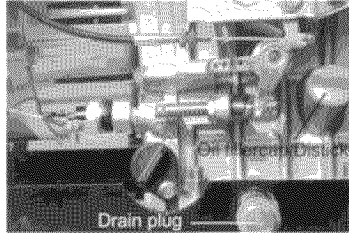

Picture 1

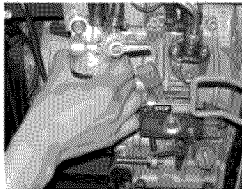

Picture 2



Picture 3

6. It is now necessary to turn the engine over **without starting it**.
 - a) **Recoil Start:** Push the decompression lever down to the non-compression position and hold it while pulling the recoil starter three times.
 - b) **Electric Start:** Turn the engine for 2-3 seconds with the decompression lever set in the *non-compression mode* and the key in the "start" position.
7. Now pull the decompression lever up and pull the recoil starter slowly until you begin to feel resistance. In this position both the intake and exhaust valves are closed which prevents rust from forming inside the engine.
8. Wipe off any oil or dirt from the engine and store your generator in a dry place.

10.Troubleshooting and Solutions

Problem	Possible Causes	Remedies
Diesel engine won't start	Not enough fuel	Refill with fuel
	Fuel valve is not open	Open the fuel valve
	The engine start lever is not in RUN position	Turn it to the RUN position
	Fuel injection pump and nozzle not delivering fuel, or not delivering sufficient fuel	Remove the nozzle and repair it at test table
	Low oil	The specified oil level should be between the upper level and the lower level
	The nozzle is dirty	Clean the nozzle
	The recoil starter is being pulled with insufficient force	Start the engine according to the start procedure
	The battery is too weak	Charge the battery or replace it with a new one
The generator is not producing power	AC circuit breaker switch not turned on	Turn it to the ON position
	The carbon brush is worn	Replace the carbon brush
	The power outlet contact is poor	Adjust the power outlet
	The rated speed is not being reached	Adjust it according to the requirements
	AVR is damaged	Replace the AVR

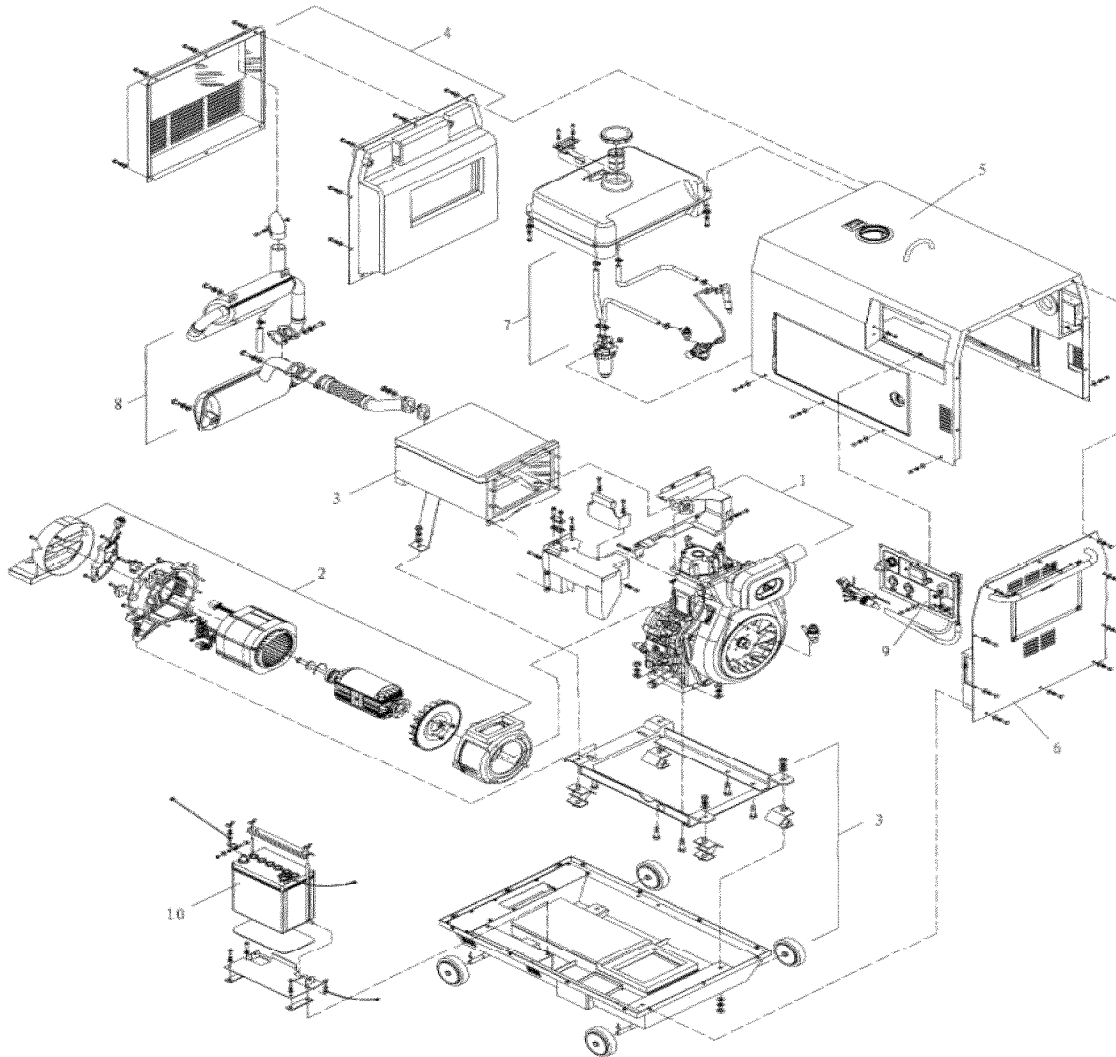

APA Part No.	Part No.	Description
APG3202-A-01-TT	951759-A-01-TT	Diesel Engine Assembly
APG3202-A-02-TT	951759-A-02-TT	Electric Machine Assembly
APG3202-A-03-TT	951759-A-03-TT	Chassis
APG3202-A-04-TT	951759-A-04-TT	Left Side Plate
APG3202-A-05-TT	951759-A-05-TT	Housing Unit
APG3202-A-06-TT	951759-A-06-TT	Right Side Plate
APG3202-A-07-TT	951759-A-07-TT	Fuel System
APG3202-A-08-TT	951759-A-08-TT	Muffler Assembly
APG3202-A-09-TT	951759-A-09-TT	Control Panel
APG3202-A-10-TT	951759-A-10-CF	Accumulator

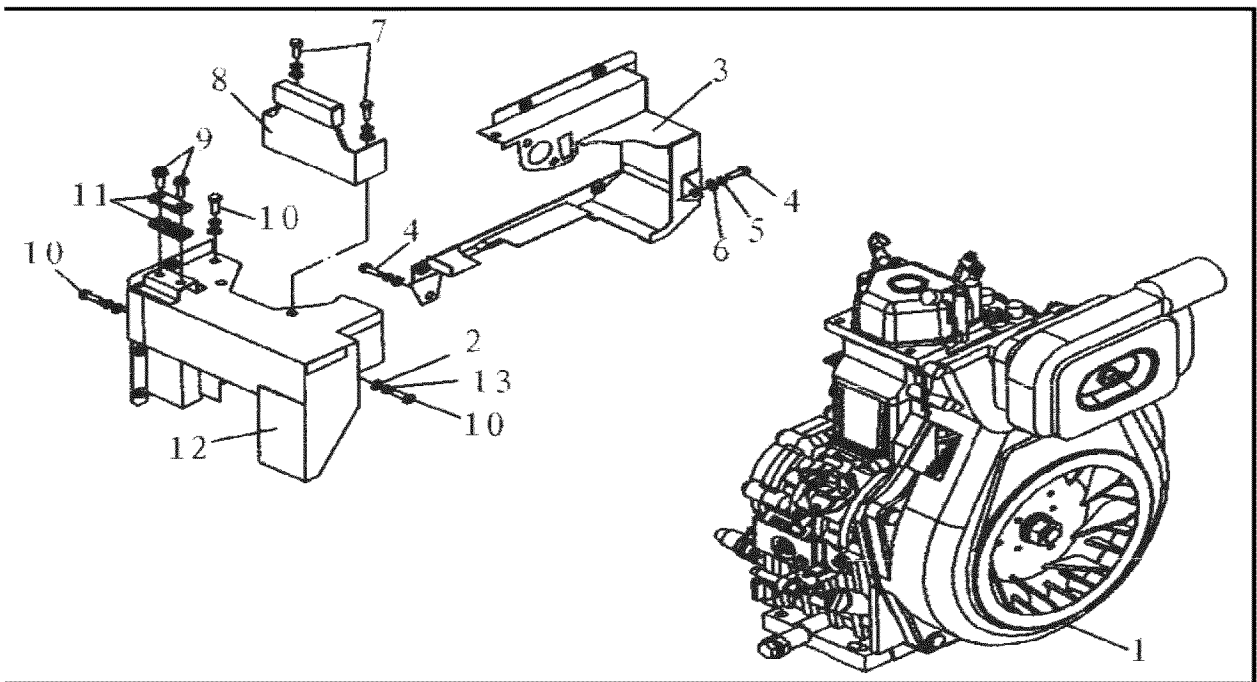

APA Part No.	Part No.	Description
APG3202-B-01-TT	951759-B-01-TT	Air Cooled Diesel
APG3202-B-02-TT	951759-B-02-TT	Gasket 6
APG3202-B-03-TT	951759-B-03-TT	Front Air Cover Weldment
APG3202-B-04-TT	951759-B-04-TT	Hexagonal Bolt M8x16
APG3202-B-05-TT	951759-B-05-TT	Elastic Gasket 8
APG3202-B-06-TT	951759-B-06-TT	Gasket 8
APG3202-B-07-TT	951759-B-07-TT	Hexagonal Bolt M8x20
APG3202-B-08-TT	951759-B-08-TT	Buffer Support Plate Unit
APG3202-B-09-TT	951759-B-09-TT	Bolt M6x30
APG3202-B-10-TT	951759-B-10-TT	Hexagonal Bolt M6x30
APG3202-B-11-TT	951759-B-11-TT	Fuel Pipe Pressure Plate Unit
APG3202-B-12-TT	951759-B-12-TT	Rear Air Cover Weldment
APG3202-B-13-TT	951759-B-13-TT	Elastic Gasket 8

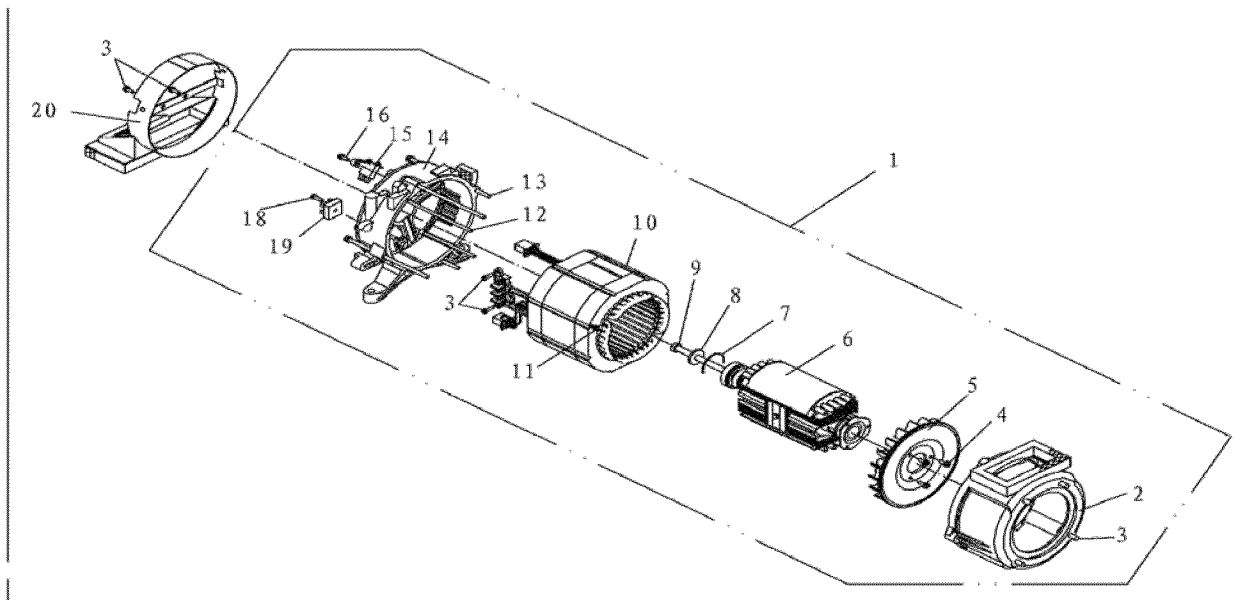

APA Part No.	Part No.	Description
APG3202-C-01-TT	951 759-C-01-TT	Electric Machine Unit
APG3202-C-02-TT	951 759-C-02-TT	Front Cover of Electric Machine
APG3202-C-03-TT	951 759-C-03-TT	Hexagonal Bolt M8x30
APG3202-C-04-TT	951 759-C-04-TT	Screw M5x12
APG3202-C-05-TT	951 759-C-05-TT	Fan
APG3202-C-06-TT	951 759-C-06-TT	Rotor
APG3202-C-07-TT	951 759-C-07-TT	Clip
APG3202-C-08-TT	951 759-C-08-TT	Gasket
APG3202-C-09-TT	951 759-C-09-TT	Bolt (locking rotor)
APG3202-C-10-TT	951 759-C-10-TT	Stator
APG3202-C-11-TT	951 759-C-11-TT	Round Nut M5
APG3202-C-12-TT	951 759-C-12-TT	Bolt M5 (locking stator)
APG3202-C-13-TT	951 759-C-13-TT	Bolt M6 (locking front cover)
APG3202-C-14-TT	951 759-C-14-TT	Rear Cover of Electric Machine
APG3202-C-15-TT	951 759-C-15-TT	Carbon Brush
APG3202-C-16-TT	951 759-C-16-TT	Screw M5x14
APG3202-C-17-TT	951 759-C-17-TT	Excitation AVR
APG3202-C-18-TT	951 759-C-18-TT	Screw M5x16
APG3202-C-19-TT	951 759-C-19-TT	Rectifier
APG3202-C-20-TT	951 759-C-20-TT	Air Cover of Electric Machine Weldment

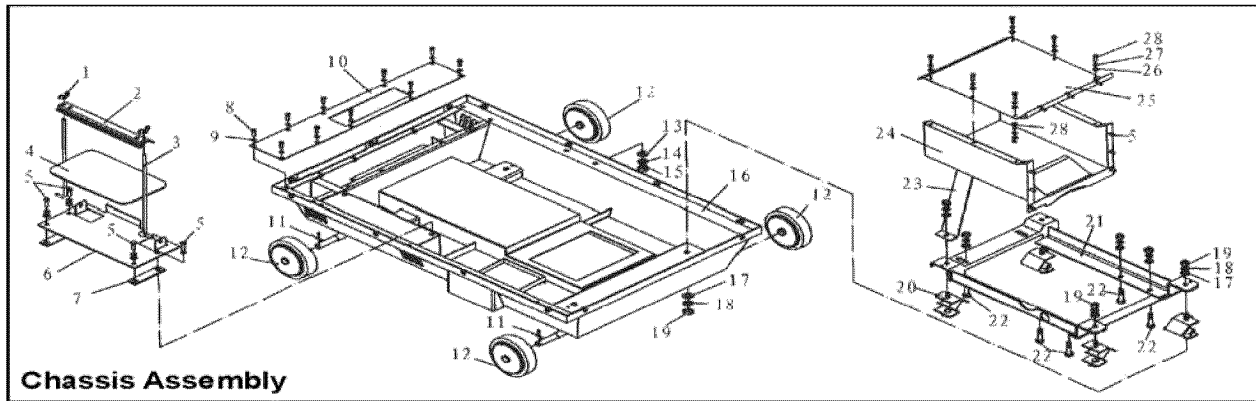

APA Part No.	Part No.	Description
APG3202-D-01-TT	951759-D-01-TT	Wing Nut M6
APG3202-D-02-TT	951759-D-02-TT	Accumulator Pressure Plate
APG3202-D-03-TT	951759-D-03-TT	Accumulator Mount Rod
APG3202-D-04-TT	951759-D-04-TT	Accumulator Washer
APG3202-D-05-TT	951759-D-05-TT	Hexagonal Bolt M6x20
APG3202-D-06-TT	951759-D-06-TT	Accumulator Support Plate
APG3202-D-07-TT	951759-D-07-TT	Accumulator Support Plate Washer
APG3202-D-08-TT	951759-D-08-TT	Screw M5x12
APG3202-D-09-TT	951759-D-09-TT	Elastic Gasket 5
APG3202-D-10-TT	951759-D-10-TT	Ventage Plate of Electric Machine
APG3202-D-11-TT	951759-D-11-TT	Cotter Pin
APG3202-D-12-TT	951759-D-12-TT	Castor
APG3202-D-13-TT	951759-D-13-TT	Gasket 8
APG3202-D-14-TT	951759-D-14-TT	Elastic Gasket 8
APG3202-D-15-TT	951759-D-15-TT	Nut M8
APG3202-D-16-TT	951759-D-16-TT	Chassis Weldment
APG3202-D-17-TT	951759-D-17-TT	Gasket 10
APG3202-D-18-TT	951759-D-18-TT	Elastic Gasket 10
APG3202-D-19-TT	951759-D-19-TT	Nut M10
APG3202-D-20-TT	951759-D-20-TT	Cushion
APG3202-D-21-TT	951759-D-21-TT	Housing Base Frame Weldment
APG3202-D-22-TT	951759-D-22-TT	Hexagonal Bolt M10x40
APG3202-D-23-TT	951759-D-23-TT	Support Plate of Heat Insulation Weldment
APG3202-D-24-TT	951759-D-24-TT	Lower Body of Heat Insulation Weldment
APG3202-D-25-TT	951759-D-25-TT	Heat Insulation Cover Plate
APG3202-D-26-TT	951759-D-26-TT	Gasket 6
APG3202-D-27-TT	951759-D-27-TT	Gasket 6
APG3202-D-28-TT	951759-D-28-TT	Bolt M6x20

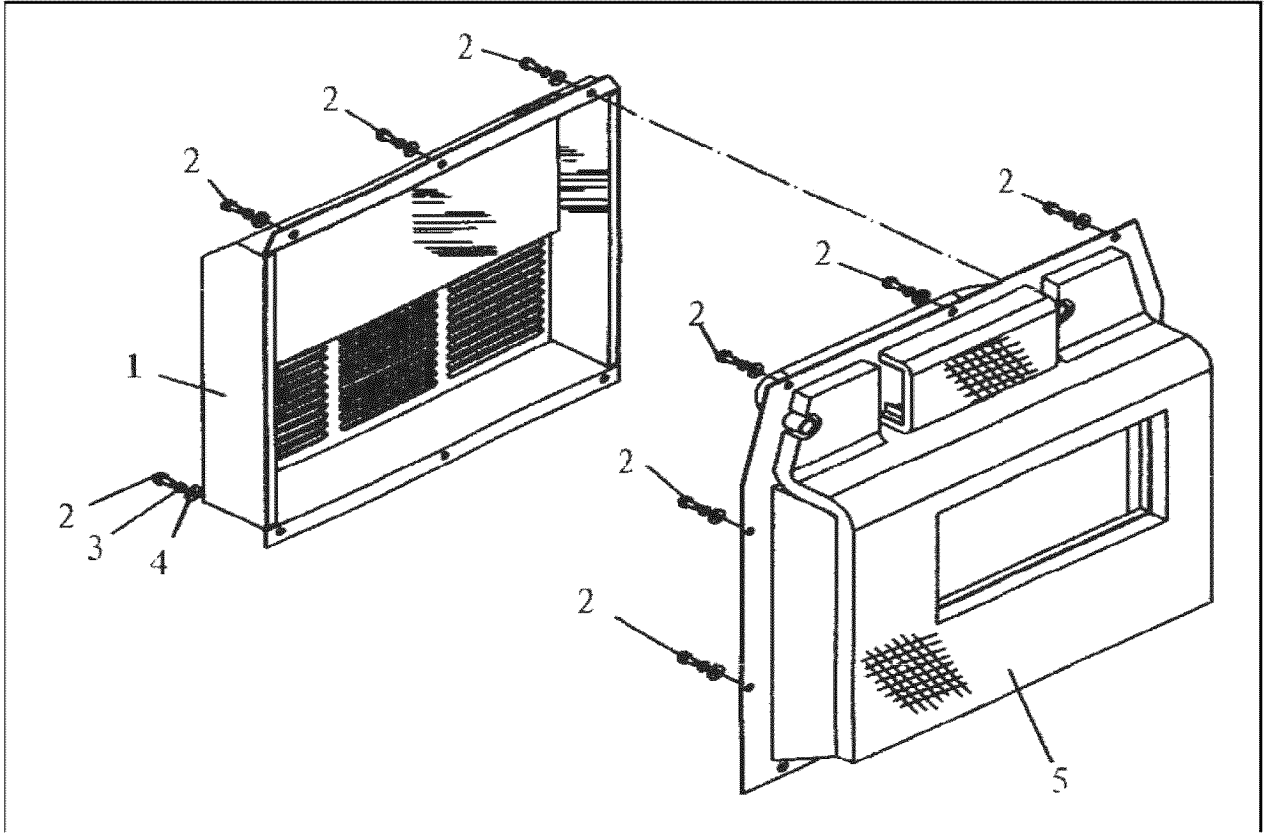

APA Part No.	Part No.	Description
APG3202-E-01-TT	951759-E-01-TT	Radiator Unit
APG3202-E-02-TT	951759-E-02-TT	Hexagonal Bolt M6x16
APG3202-E-03-TT	951759-E-03-TT	Elastic Gasket 6
APG3202-E-04-TT	951759-E-04-TT	Big Gasket 6
APG3202-E-05-TT	951759-E-05-TT	Left Side Plate Weldment

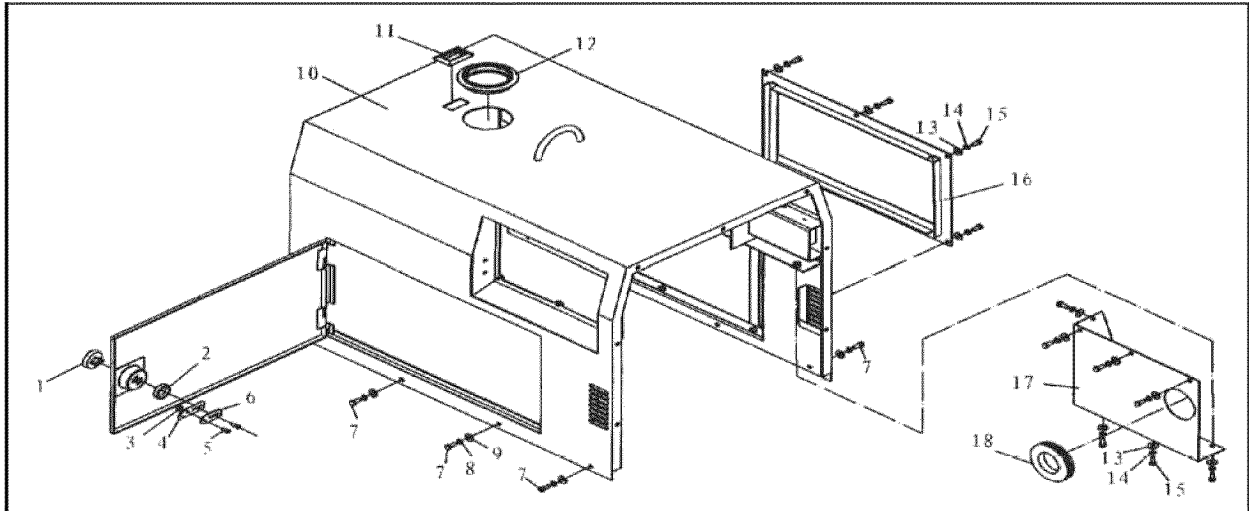

APA Part No.	Part No.	Description
APG3202-F-01-TT	951759-F-01-TT	Lock Knob
APG3202-F-02-TT	951759-F-02-TT	Washer
APG3202-F-03-TT	951759-F-03-TT	Nut M5
APG3202-F-04-TT	951759-F-04-TT	Lock
APG3202-F-05-TT	951759-F-05-TT	Screw M5X12
APG3202-F-06-TT	951759-F-06-TT	Lock Mount Plate
APG3202-F-07-TT	951759-F-07-TT	Hexagonal Bolt M6x16
APG3202-F-08-TT	951759-F-08-TT	Elastic Gasket 6
APG3202-F-09-TT	951759-F-09-TT	Big Gasket 6
APG3202-F-10-TT	951759-F-10-TT	Housing Weldment
APG3202-F-11-TT	951759-F-11-TT	Window Mount Sheath
APG3202-F-12-TT	951759-F-12-TT	Fuel Tank Vent Cushion
APG3202-F-13-TT	951759-F-13-TT	Big Gasket 6
APG3202-F-14-TT	951759-F-14-TT	Elastic Gasket 6
APG3202-F-15-TT	951759-F-15-TT	Bolt M6x16
APG3202-F-16-TT	951759-F-16-TT	Rear Plate Weldment
APG3202-F-17-TT	951759-F-17-TT	Filter Seal Plate
APG3202-F-18-TT	951759-F-18-TT	Air Cleaner Cushion

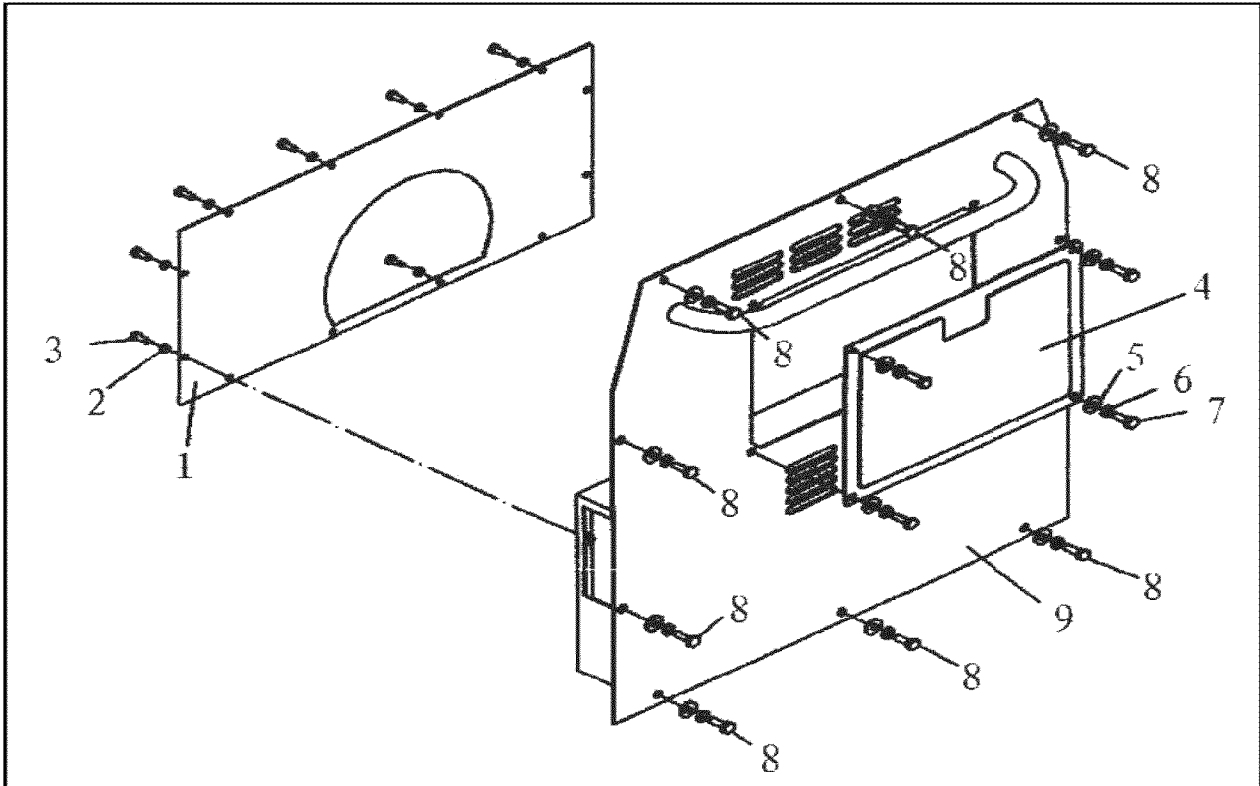

APA Part No.	Part No.	Description
APG3202-G-01-TT	951759-G-01-TT	Tank Cover Plate
APG3202-G-02-TT	951759-G-02-TT	Elastic Gasket 5
APG3202-G-03-TT	951759-G-03-TT	Screw M5x12
APG3202-G-04-TT	951759-G-04-TT	Air Cleaner Cover Plate
APG3202-G-05-TT	951759-G-05-TT	Big Gasket 6
APG3202-G-06-TT	951759-G-06-TT	Elastic Gaske 6
APG3202-G-07-TT	951759-G-07-TT	Bolt M6x16
APG3202-G-08-TT	951759-G-08-TT	Hexagonal Bolt M6x16
APG3202-G-09-TT	951759-G-09-TT	Right Side Plate Weldment

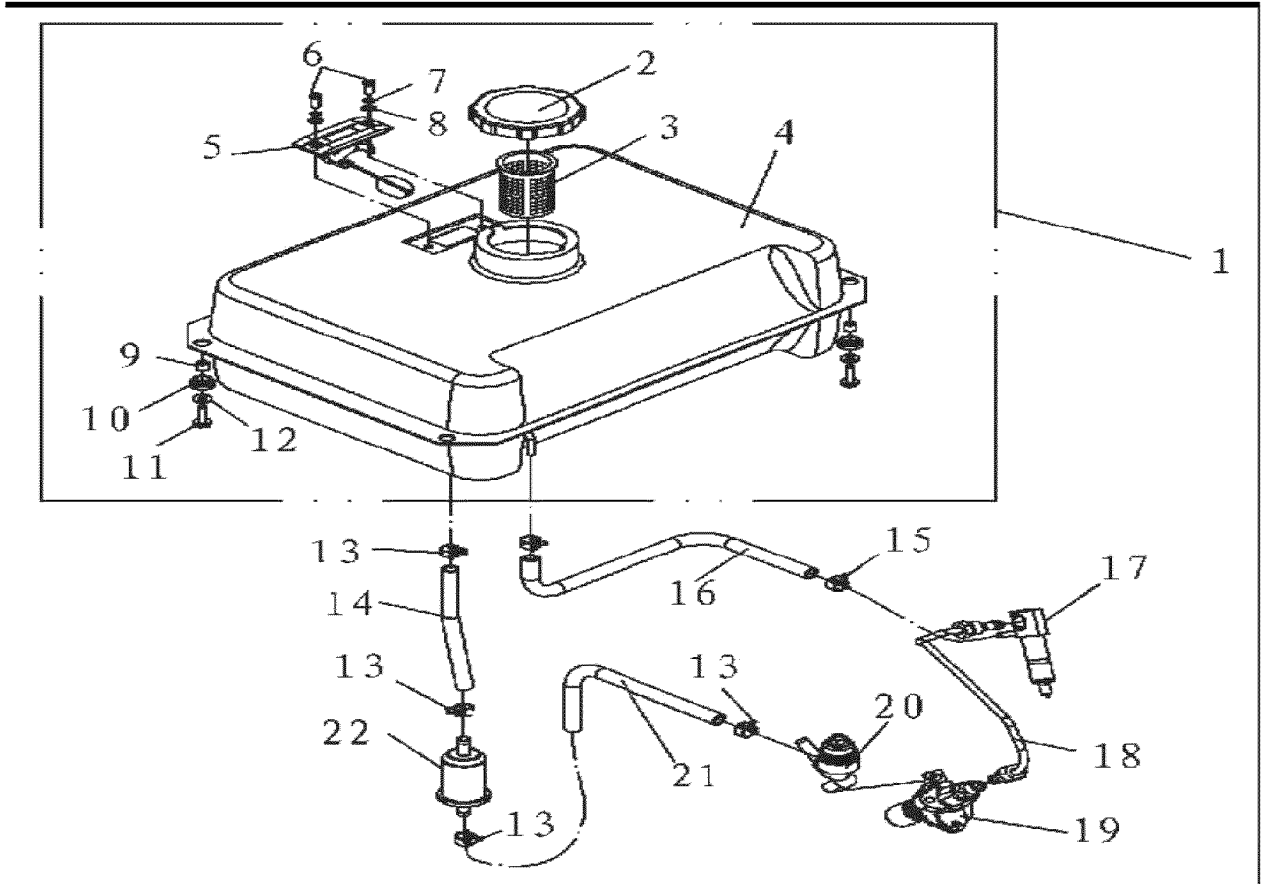

APA Part No.	Part No.	Description
APG3202-H-01-TT	951759-H-01-TT	Fuel Tank
APG3202-H-02-TT	951759-H-02-TT	Fuel Tank Cover
APG3202-H-03-TT	951759-H-03-TT	Fuel Filter
APG3202-H-04-TT	951759-H-04-TT	Fuel Tank Weldment
APG3202-H-05-TT	951759-H-05-TT	Oil Indicator
APG3202-H-06-TT	951759-H-06-TT	Screw M5x12
APG3202-H-07-TT	951759-H-07-TT	Elastic Gasket 5
APG3202-H-08-TT	951759-H-08-TT	Gasket 5
APG3202-H-09-TT	951759-H-09-TT	Sheath
APG3202-H-10-TT	951759-H-10-TT	Cushion
APG3202-H-11-TT	951759-H-11-TT	Bolt M6x16
APG3202-H-12-TT	951759-H-12-TT	Gasket 6
APG3202-H-13-TT	951759-H-13-TT	Clip I
APG3202-H-14-TT	951759-H-14-TT	Fuel Pipe I
APG3202-H-15-TT	951759-H-15-TT	Clip II
APG3202-H-16-TT	951759-H-16-TT	Fuel Return Pipe
APG3202-H-17-TT	951759-H-17-TT	Nozzle Tip
APG3202-H-18-TT	951759-H-18-TT	High Pressure Fuel Pipe
APG3202-H-19-TT	951759-H-19-TT	Fuel Pump Unit
APG3202-H-20-TT	951759-H-20-TT	Fuel Control Valve Unit
APG3202-H-21-TT	951759-H-21-TT	Fuel Pipe II
APG3202-H-22-TT	951759-H-22-TT	Fuel filter

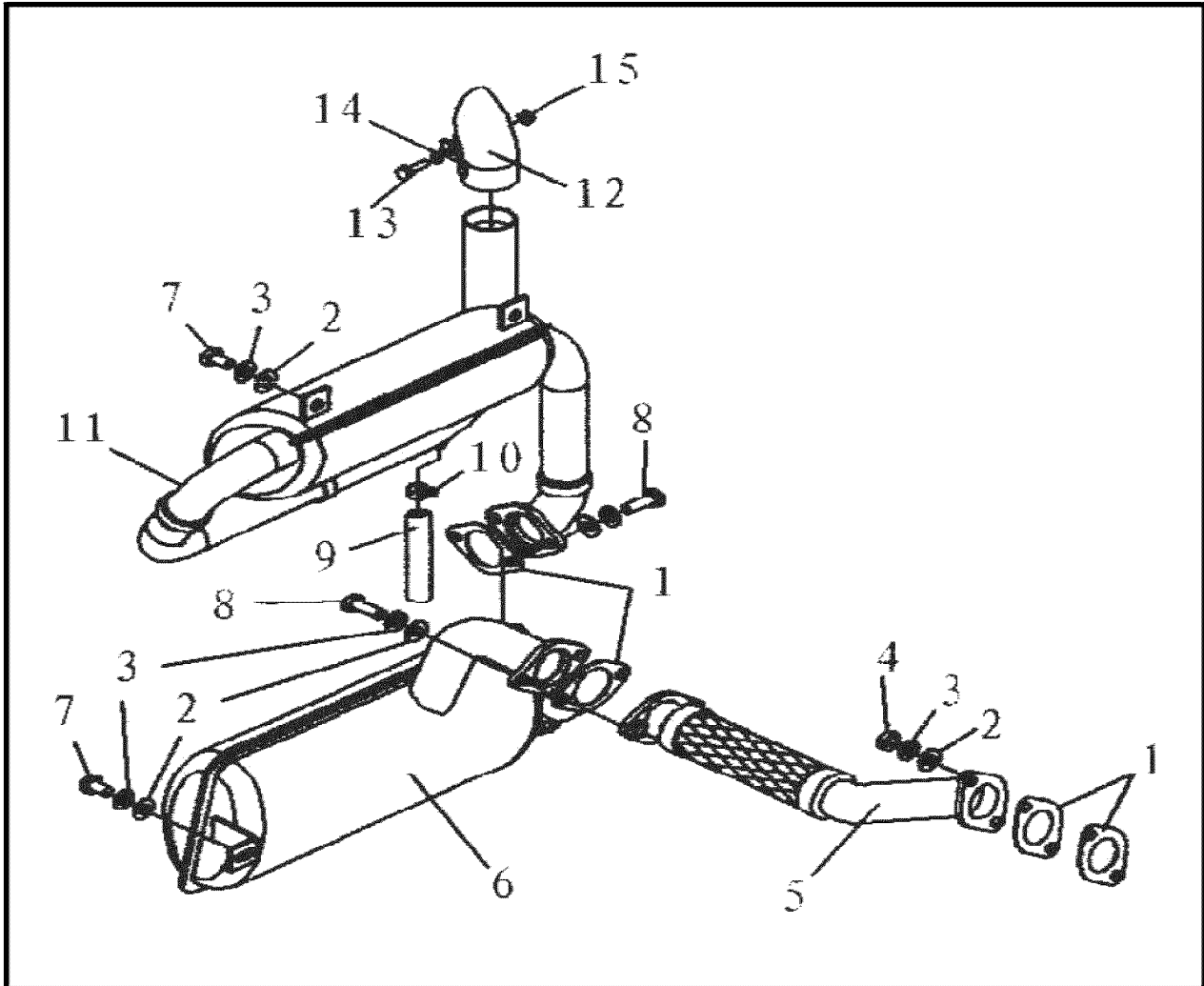

APA Part No.	Part No.	Description
APG3202-I-01-TT	951759-I-01-TT	Exhaust Pipe Washer
APG3202-I-02-TT	951759-I-02-TT	Gasket 8
APG3202-I-03-TT	951759-I-03-TT	Elastic Gasket 8
APG3202-I-04-TT	951759-I-04-TT	Nut M8
APG3202-I-05-TT	951759-I-05-TT	Exhaust Pipe Unit
APG3202-I-06-TT	951759-I-06-TT	One-lever Muffler Unit
APG3202-I-07-TT	951759-I-07-TT	Bolt M8x16
APG3202-I-08-TT	951759-I-08-TT	Bolt M8x30
APG3202-I-09-TT	951759-I-09-TT	Tail-end Gas Outlet Hose
APG3202-I-10-TT	951759-I-10-TT	Clip I
APG3202-I-11-TT	951759-I-11-TT	Second-lever Muffler Unit
APG3202-I-12-TT	951759-I-12-TT	Tail-end Gas Return Outlet Weldment
APG3202-I-13-TT	951759-I-13-TT	Bolt M6x30
APG3202-I-14-TT	951759-I-14-TT	Gasket 6
APG3202-I-15-TT	951759-I-15-TT	Nut M6

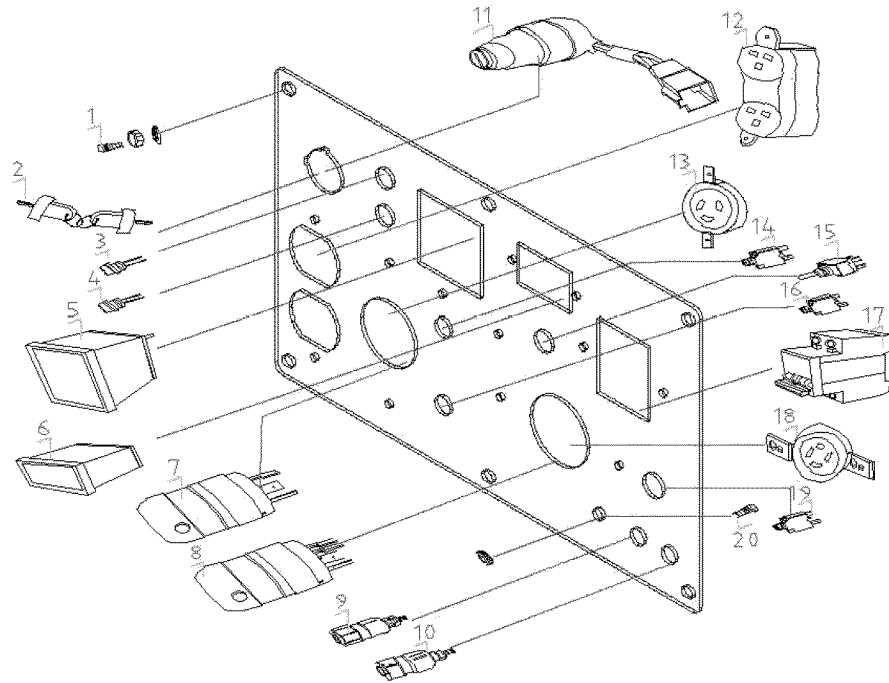

APA Part No.	Part No.	Description
APG3202-J-01-TT	951759-J-01-TT	Screw M6X 12
APG3202-J-02-TT	951759-J-02-TT	Start Key
APG3202-J-03-TT	951759-J-03-TT	Power Indicator
APG3202-J-04-TT	951759-J-04-TT	Low oil pressure Indicator
APG3202-J-05-TT	951759-J-05-TT	Voltmeter
APG3202-J-06-TT	951759-J-06-TT	Hour meter
APG3202-J-07-TT	951759-J-07-TT	3-prong plug
APG3202-J-08-TT	951759-J-08-TT	4-prong plug
APG3202-J-09-TT	951759-J-09-TT	DC output "-"
APG3202-J-10-TT	951759-J-10-TT	DC output "+"
APG3202-J-11-TT	951759-J-11-TT	Ignition switch
APG3202-J-12-TT	951759-J-12-TT	American twin socket
APG3202-J-13-TT	951759-J-13-TT	3-prong 120V receptacle
APG3202-J-14-TT	951759-J-14-TT	AC125V/20A overload protection switch
APG3202-J-15-TT	951759-J-15-TT	Voltage transfer switch
APG3202-J-16-TT	951759-J-16-TT	AC125V/30A overload protection switch
APG3202-J-17-TT	951759-J-17-TT	Circuit breaker
APG3202-J-18-TT	951759-J-18-TT	4-prong 120V/240V receptacle
APG3202-J-19-TT	951759-J-19-TT	DC12V/8.3A overload switch
APG3202-J-20-TT	951759-J-20-TT	Ground screw

BATTERY INSTALLATION

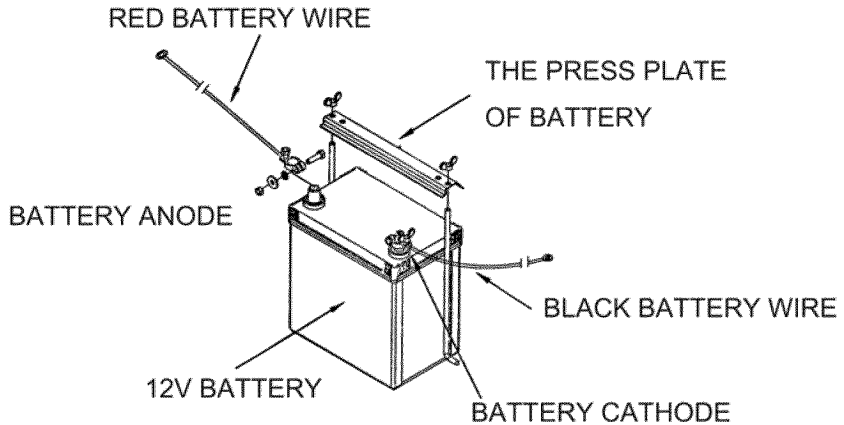

1. Loosen the two bolts on the battery press plate.
2. Take out the battery.
3. Connect the red battery wire to the anode.
4. Connect the black battery wire to the cathode.
5. Install the battery to the generator according to the drawing.