

ITEM# 1-1-37001

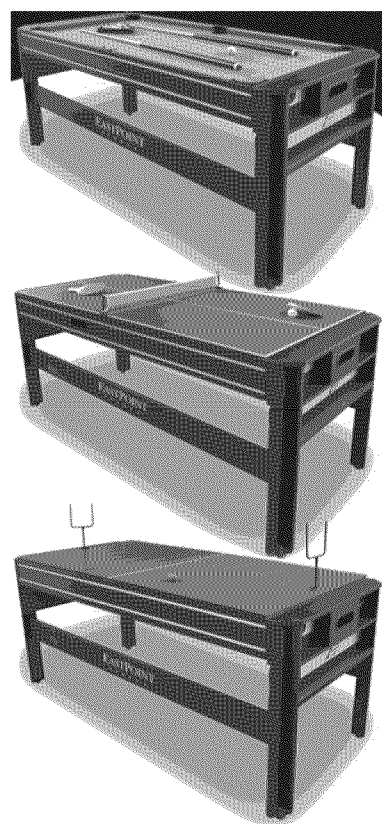

72 in / 1,83 m
SWIVEL TABLE

4 Great Games in 1 - 4 gran opciones de juego

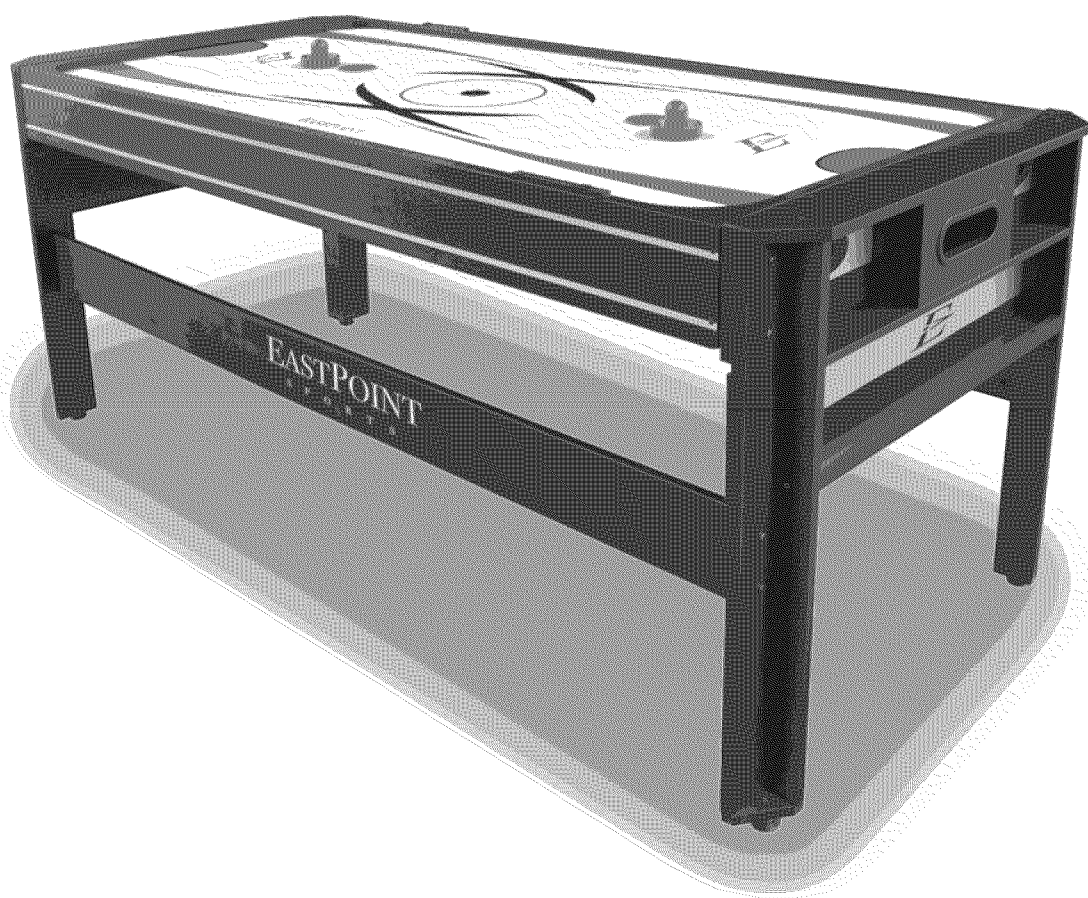

Assembly Instructions

Model # 37001

www.eastpointsports.com

TWO OR MORE ADULTS REQUIRED FOR ASSEMBLY

IMPORTANT SAFETY INSTRUCTIONS

- 1. Read all instructions** – All the safety and operating instructions should be read carefully before this Hover Hockey table can be operated or played.
- 2. Caution** – This is not a toy and is intended for use by or under the supervision of adults. Adults should review safety guidelines with children to avoid possible risk of electric shock or other injuries.
- 3. Caution** – This table rotates on a central axis and can pose a small risk of a pinch hazard. Keep hands clear when swivel cabinet is in motion.
- 4. Power Sources** – This Hover Hockey game should be operated only from 100-125V A.C., 50/60 cycle current as indicated on the identification label. If you are not sure of the type of power supply to your home, consult your appliance dealer or local power company.
- 5. Power Cord Protection** – Power cord should be routed so that it is not likely to be walked on or pinched by items placed upon or against it. Pay particular attention to cords at plugs, convenience receptacles, and the point of exit from the game.
- 6. Overloading** – Do not overload wall outlets and extension cords as this can result in a risk of fire or electric shock.
- 7. Object and Liquid Entry** – Never push objects of any kind into this game through openings as they may touch dangerous voltage points or short-out parts which could result in a fire or electric shock. Never spill liquid of any kind on the game. If cleaning the surface, follow the recommended manufacturer instructions or call technical support for guidance.
- 8. Ventilation** – Openings in the game are provided for the exhaust air to create a cushion/floating effect. The openings on the air blower are for the intake air. Keep clear of the air blower during operation. Do not allow hand, hair, or any other objects near the intake openings. To ensure reliable operation of the game and protect it from overheating, these openings must not be blocked or covered.
- 9. Damage Requiring Service** – Unplug the game from the wall outlet/receptacle. Do not attempt to service the blower yourself as while opening and/or removing covers may expose you/others to dangerous voltage or other hazards. Refer servicing to qualified service personnel under the following conditions:
 - When the power supply cord is damaged.
 - If liquid has spilled, or objects have fallen into the blower.
 - When the air blower exhibits a distinct change in performance – i.e. abnormal noise, too much/too little air flow, this indicates a need for service
- 10. Grounding or Polarization** – This game is equipped with a polarized alternating current line plug (a plug having one blade wider than the other). This plug will fit into the power outlet only one way. This is a safety feature. If you are unable to insert the plug fully into the outlet, try reversing the plug. If the plug should still fail to fit, contact your electrician to replace your obsolete outlet. DO NOT defeat the safety purpose of the polarized plug.
- 11. CAUTION – ELECTRICALLY OPERATED PRODUCT** – Not recommended for children under 8 years of age. As with all electrical products, precautions should be observed during handling and use to reduce the risk of electric shock.
- 12. We recommend** – that the game be periodically examined for conditions that may result in the risk of fire, electrical shock, or injury to persons. In the event such conditions exist, the game should not be used until properly repaired.
- 13. Storage Conditions** – This product is made from wood based components and is sensitive to extreme temperatures and moisture / humidity. Subject to these conditions will effect game play, cosmetics and longevity.

Save These INSTRUCTIONS

Warning: To Reduce The Risk Of Fire Or Electric Shock, Do Not Use This Fan With Any Solid-State Speed Control Device



EASTPOINT

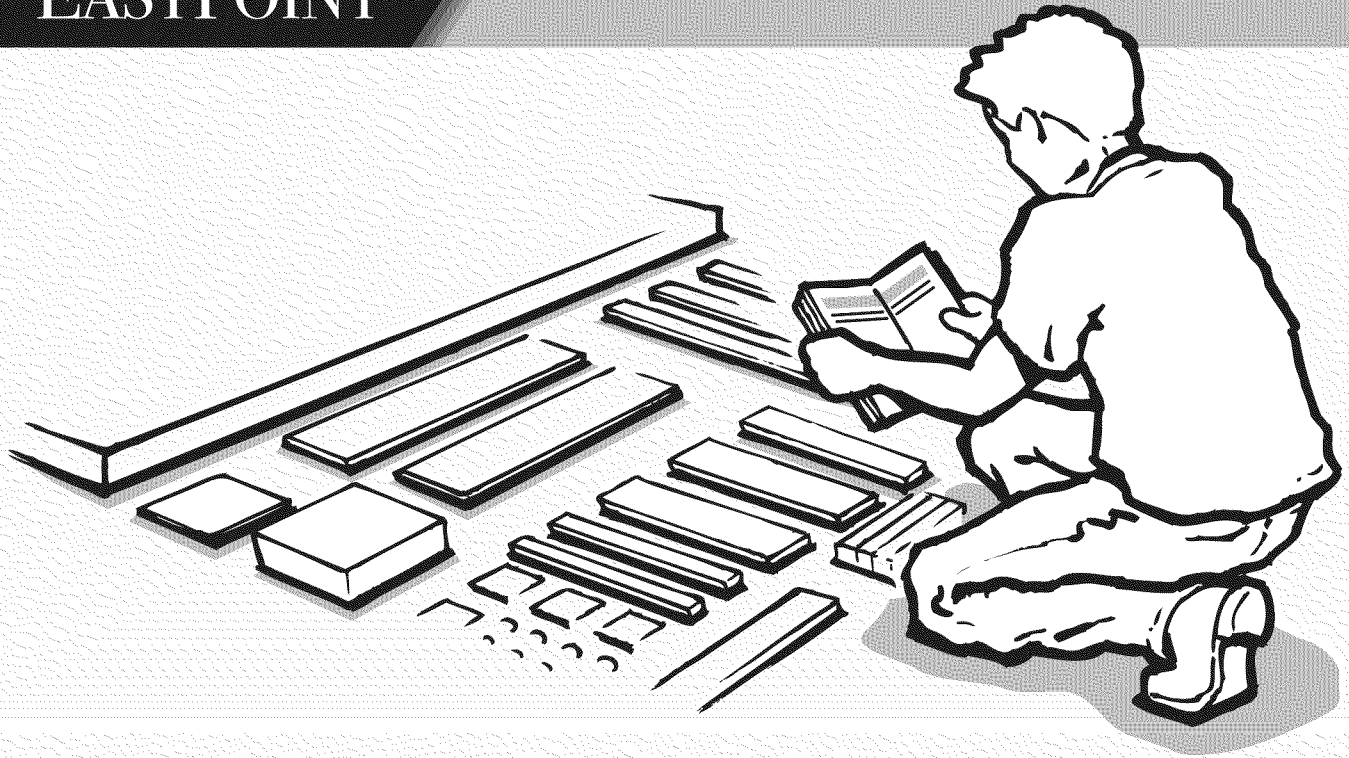

IMPORTANT - Lay out all parts before you begin

- Please review the parts identifier and make sure that you have all parts before beginning assembly.
- If any questions or issues, please contact us at 1-973-585-4747 **BEFORE** returning the product to the original place of purchase.
- Please keep your original sales receipt. Staple it on the adjacent page in the space provided for future reference/use. It will be required to receive service help or parts under warranty.

CONTACT INFO

Hours

Monday to Friday
(9:00am to 5pm EST)

Technical Support or Replacement Parts

Email us at: consumerservice@eastpointsports.com
Visit us at: www.eastpointsports.com
Call: 973-585-4747

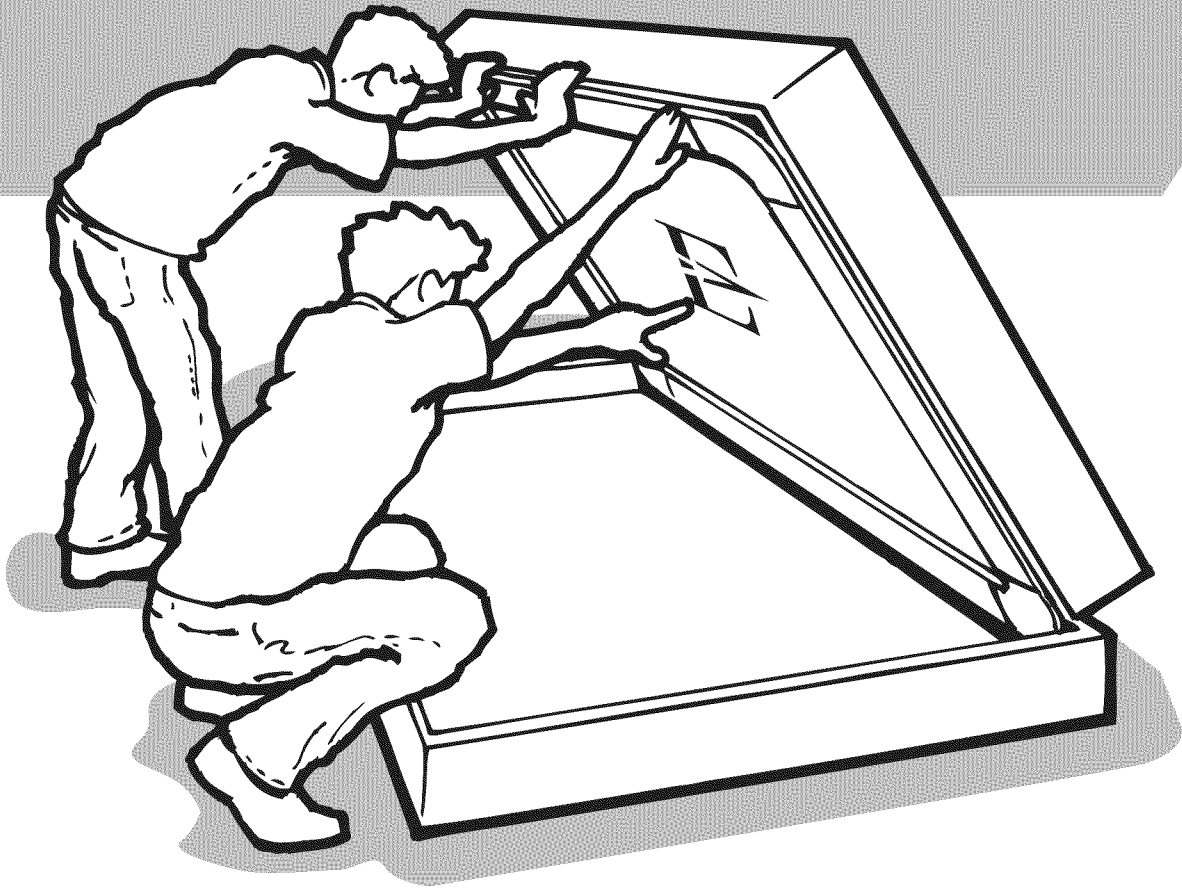

BEFORE BUILDING - Please inspect your playfield

Your Cabinet (holds Billiard table and Hockey Playfield) is **NOT replaceable**. Any damage that exists to your playfield is not repairable under warranty. If your playfield is damaged, the entire game must be returned to the original place of purchase for an exchange.

**Please attach
RECEIPT HERE**

It will be required to receive service help or parts under warranty.

TOOLS

Required

- 1 - Phillips Head Screwdriver (Standard Size) – Not Included
- 1 – Hex Wrench – Included
- 1 – Allen Wrench - Included

Recommended (Not Required):

- Electric Screwdriver or Power Driver
CAUTION – DO NOT OVER TIGHTEN. Over Tightening will result in irreparable damage to the product. If using, please make sure that the tool is set to a very low torque to prevent damage to the product.
- Socket Wrench Set

How to use the: PARTS IDENTIFIER

Before you begin assembly, please make sure that you have all the parts listed and in the correct quantities. This will ensure the quickest and most organized assembly.

Be sure to work on the assembly on a soft non-marring surface such as carpet or the inside of the corrugate box top to prevent causing damage to the table surface during assembly.

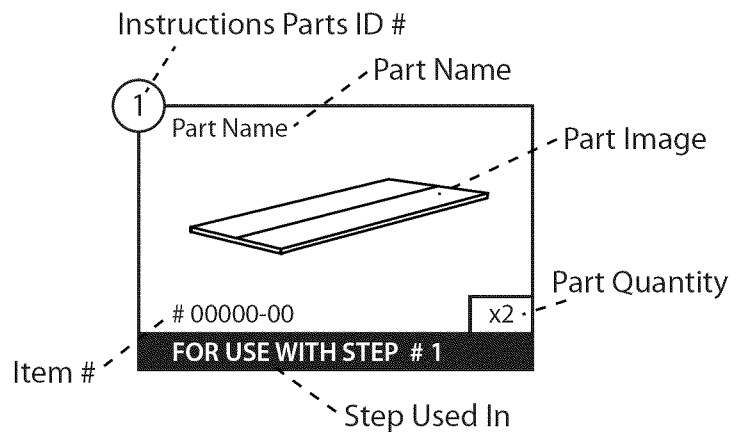

PARTS IDENTIFIER

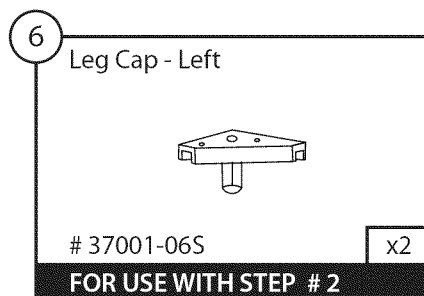
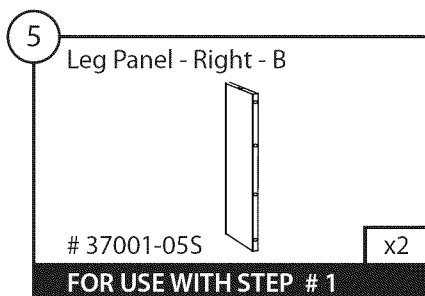
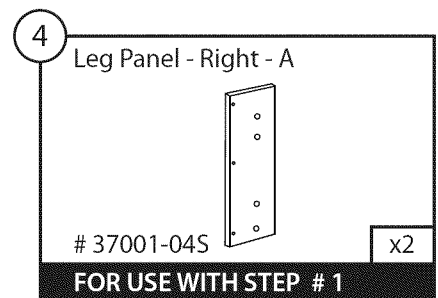
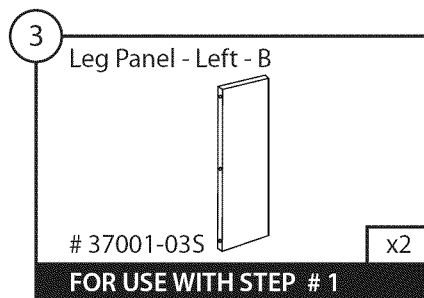
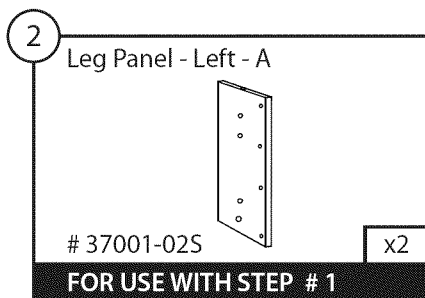

Components



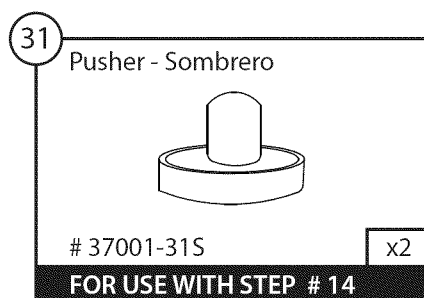
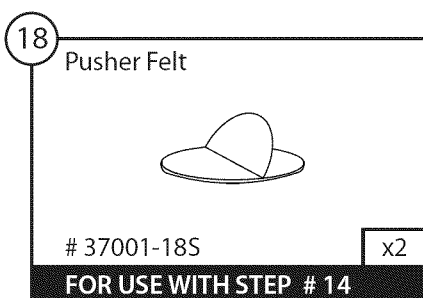
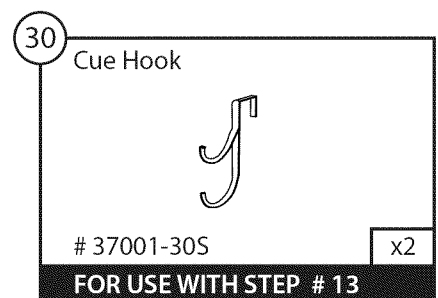
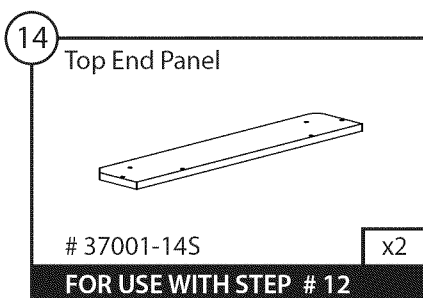
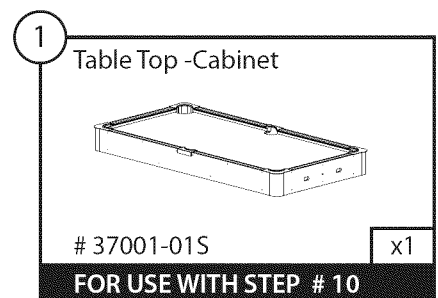
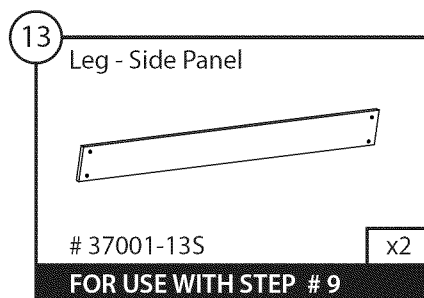
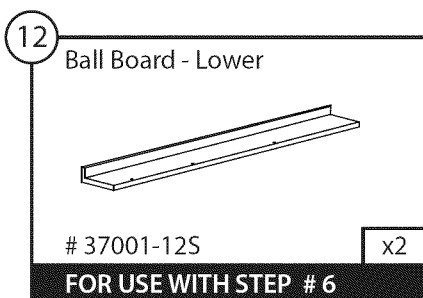
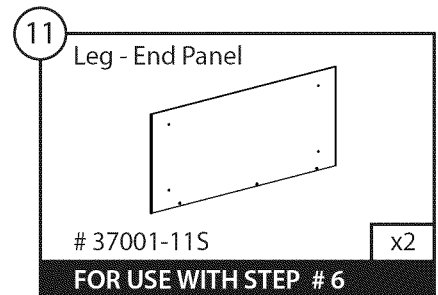
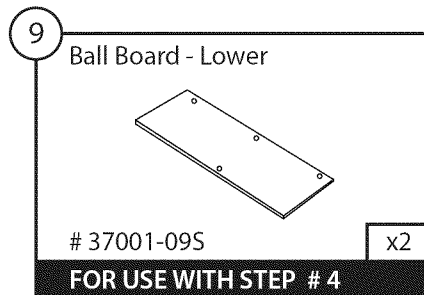
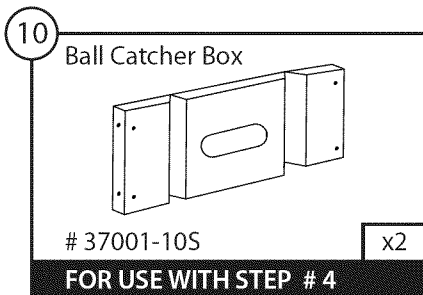
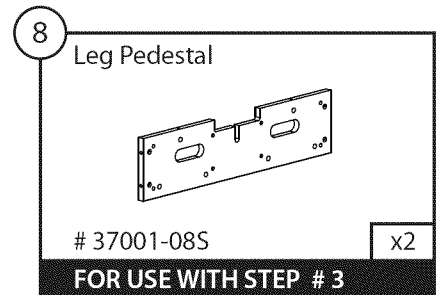
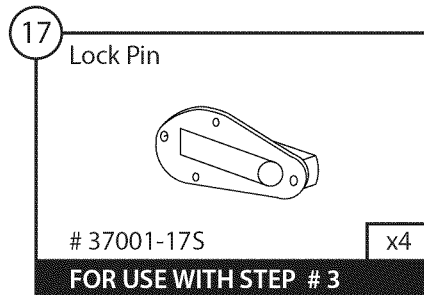



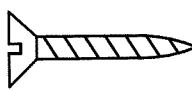

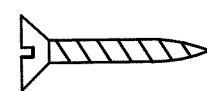
Components cont.

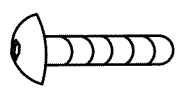
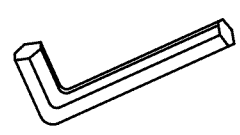
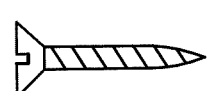

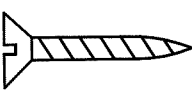

Hardware

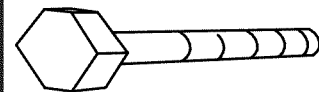
<p>60 Screw - Wood - 4 x 44.5mm</p>  <p># 37001-60S x16</p> <p>FOR USE WITH STEP # 1</p>	<p>61 Screw - Wood - 4 x 25mm</p>  <p># 37001-61S x8</p> <p>FOR USE WITH STEP # 2</p>	<p>62 Screw - Wood - 3 x 15mm</p>  <p># 37001-62S x16</p> <p>FOR USE WITH STEP # 3</p>	<p>63 Screw - Wood - 4 x 44.5mm</p>  <p># 37001-60S x16</p> <p>FOR USE WITH STEP # 4</p>
--	---	---	--

<p>64 Bolt - Allen - 8 x 32mm</p>  <p># 37001-64S x8</p> <p>FOR USE WITH STEP # 5</p>	<p>65 Wrench - Allen Style</p>  <p># 37001-65S x1</p>	<p>66 Screw - Wood - 4 x 44.5mm</p>  <p># 37001-60S x6</p> <p>FOR USE WITH STEP # 6</p>	<p>67 Screw - Wood - 4 x 12mm</p>  <p># 37001-67S x8</p> <p>FOR USE WITH STEP # 7</p>
---	--	--	---

<p>68 Screw - Wood - 4 x 44.5mm</p>  <p># 37001-60S x4</p> <p>FOR USE WITH STEP # 8</p>	<p>69 Barrel Nut - 8mm</p>  <p># 37001-69S x8</p> <p>FOR USE WITH STEP # 9</p>	<p>70 Bolt - Hex Head - 8 x 63.5mm</p>  <p># 37001-70S x8</p>	<p>71 Washer - Metal - 8mm</p>  <p># 37001-71S x8</p>
---	--	---	--

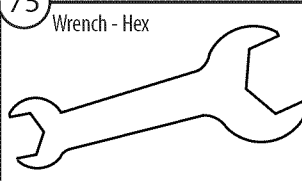
<p>72 Bolt - Hex - 12mm</p>  <p># 37001-72S x2</p> <p>FOR USE WITH STEP # 10</p>	<p>73 Washer - Metal - 12mm</p>  <p># 37001-73S x2</p>	<p>74 Washer - Molded - 12mm</p>  <p># 37001-74S x2</p>	<p>75 Wrench - Hex</p>  <p># 37001-75S x1</p>
--	---	---	--

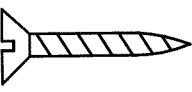
<p>76 Screw - Wood - 4 x 44.5mm</p>  <p># 37001-60S x10</p> <p>FOR USE WITH STEP # 12</p>

Accessories

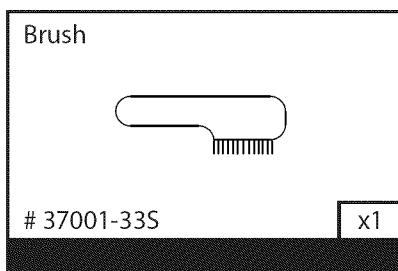
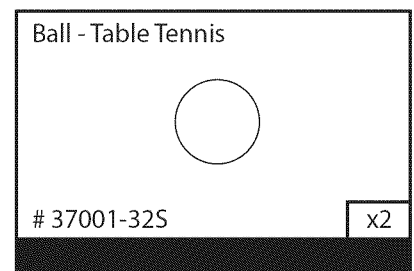
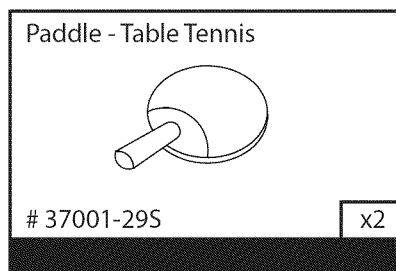
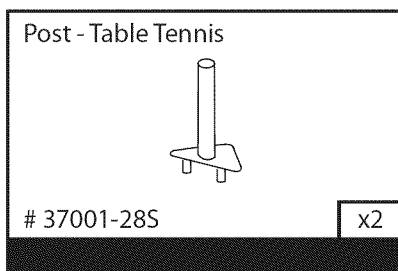
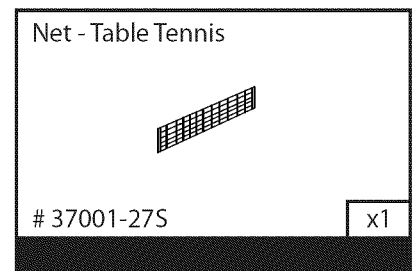
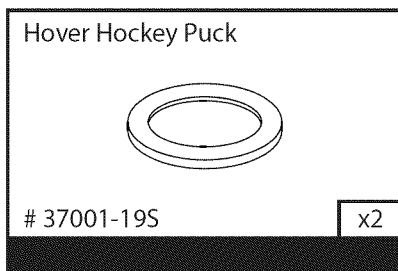
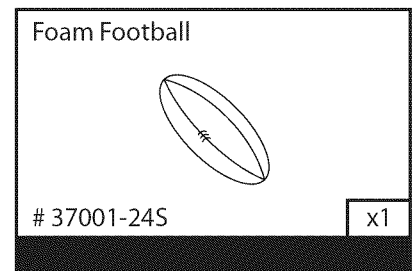
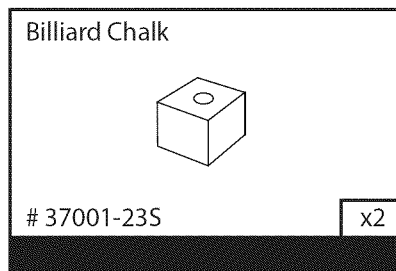
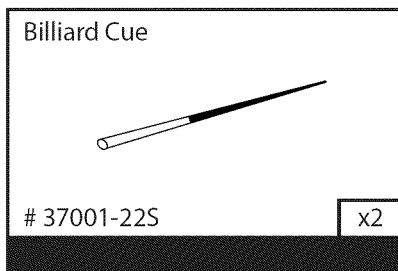
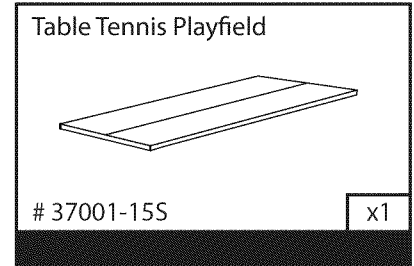
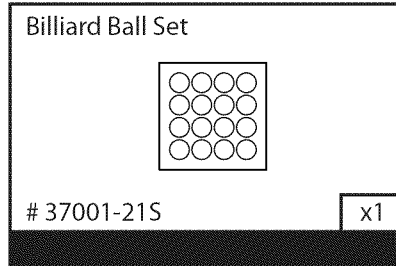
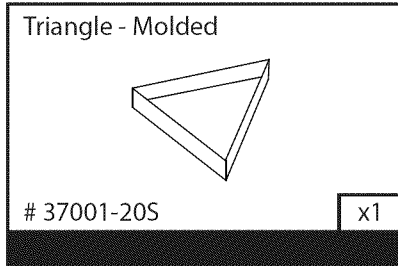

ASSEMBLY INSTRUCTIONS

BEFORE

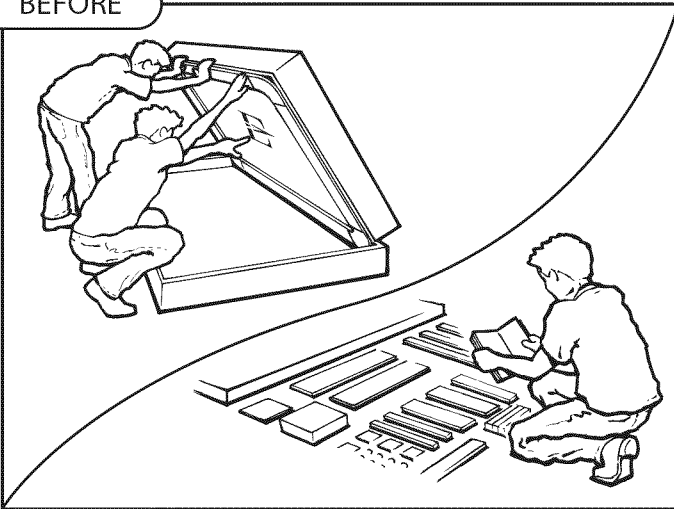

NOTE:

BEFORE BUILDING - Please inspect your playfield and layout all your parts

Your Cabinet (holds Billiard table and Hockey Playfield) is NOT replaceable. Any damage that exists to your playfield is not repairable under warranty. If your playfield is damaged, the entire game must be returned to the original place of purchase for an exchange.

STEP 1

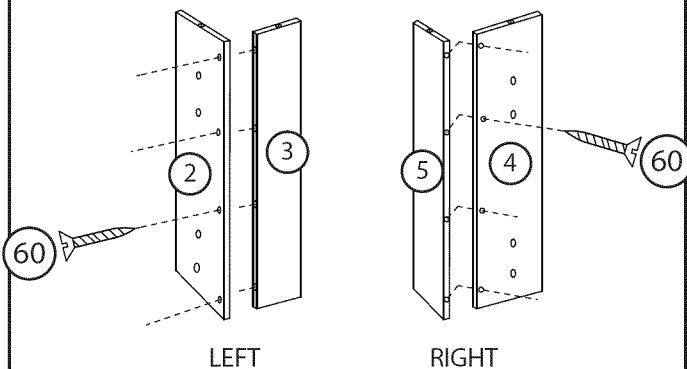

COMPONENTS

COMPONENTS	QTY.
② Leg Panel - Left - A	x2
③ Leg Panel - Left - B	x2
④ Leg Panel - Right - A	x2
⑤ Leg Panel - Right - B	x2

NOTE:

Repeat for all 4 legs.

HARDWARE

HARDWARE	QTY.
⑥⑩ Screw - Wood - 4 x 44.5mm	x16

STEP 2

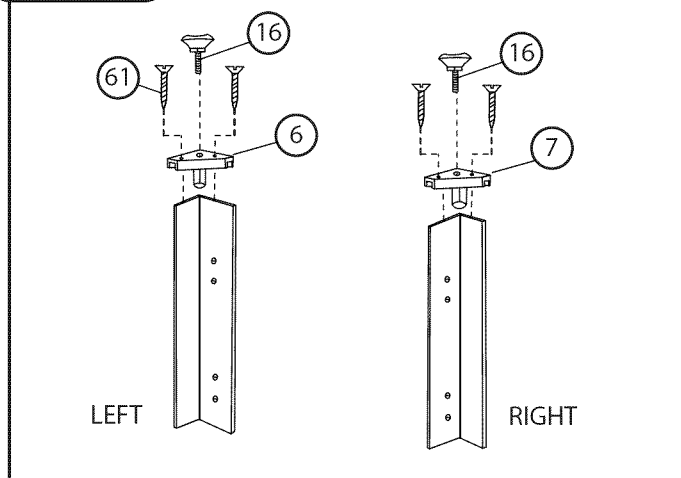

COMPONENTS

COMPONENTS	QTY.
⑥ Leg Cap - Left	x2
⑦ Leg Cap - Right	x2
⑩⑥ Leg Leveler	x4
Step 1 Assemblies	x2

NOTES

Repeat for all 4 legs.

HARDWARE

HARDWARE	QTY.
⑥⑩① Screw - Wood - 4 x 25mm	x8

STEP 3

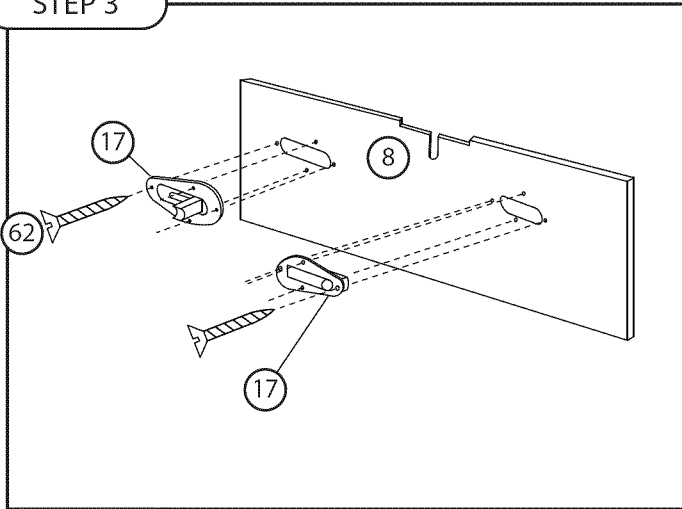

COMPONENTS

COMPONENTS	QTY.
(17) Lock Pin	x4
(8) Leg Pedestal	x2

HARDWARE

HARDWARE	QTY.
(62) Screw - Wood - 3 x 15mm	x16

NOTE:

Repeat for both ends.

Do not overtighten.

STEP 4

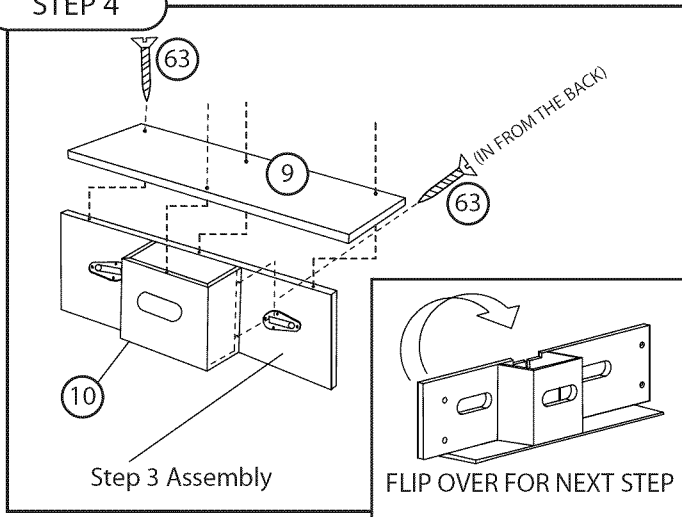

COMPONENTS

COMPONENTS	QTY.
(10) Ball Catcher Box	x2
(9) Ball Board - Lower	x2
Step 3 Assembly	x2

HARDWARE

HARDWARE	QTY.
(63) Screw - Wood - 4 x 44.5mm	x16

NOTE:

Repeat for both ends.

When complete, flip over.

STEP 5

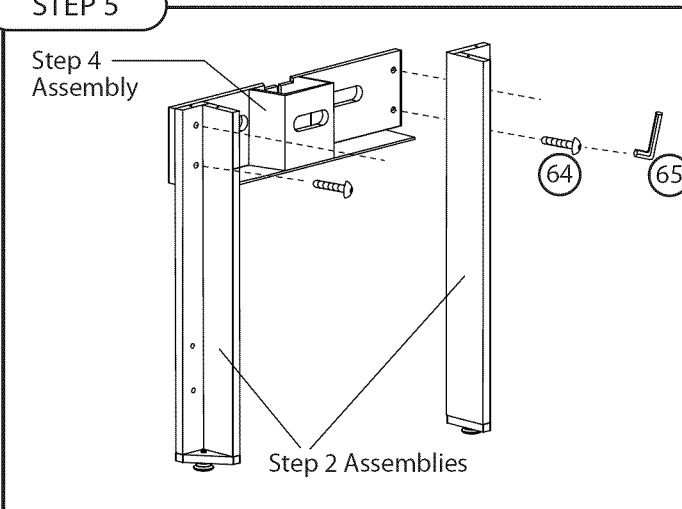

COMPONENTS

COMPONENTS	QTY.
Step 2 Assembly	x4
Step 4 Assembly	x2

HARDWARE

HARDWARE	QTY.
(64) Bolt - Allen - 8 x 32mm	x8
(65) Wrench - Allen Style	x1

NOTES

Repeat for both ends.

STEP 6

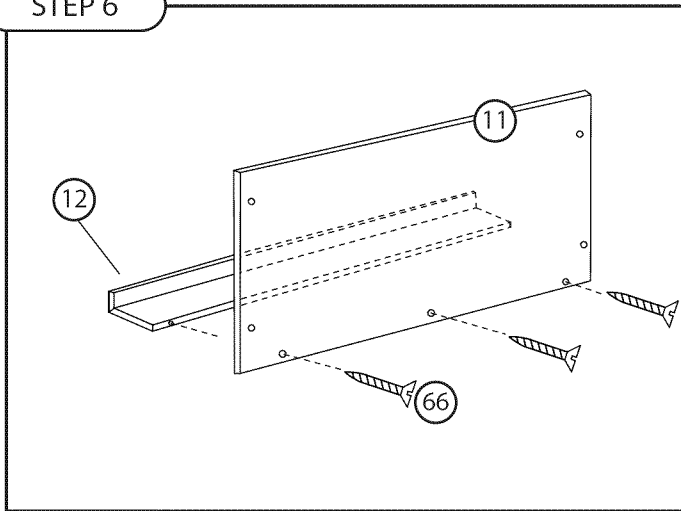

COMPONENTS **QTY.**

(11) Leg - End Panel	x2
(12) Ball Board - Lower	x2

NOTE:

Repeat for both ends.

HARDWARE **QTY.**

(66) Screw - Wood - 4 x 44.5mm	x6
--------------------------------	----

STEP 7

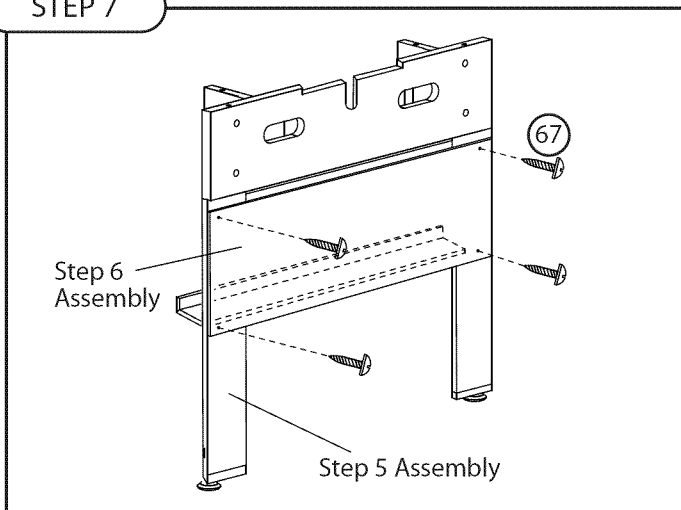

COMPONENTS **QTY.**

Step 5 Assembly	x2
Step 6 Assembly	x2

NOTE:

Repeat for both ends.

HARDWARE **QTY.**

(67) Screw - Wood - 4 x 12 mm	x8
-------------------------------	----

STEP 8

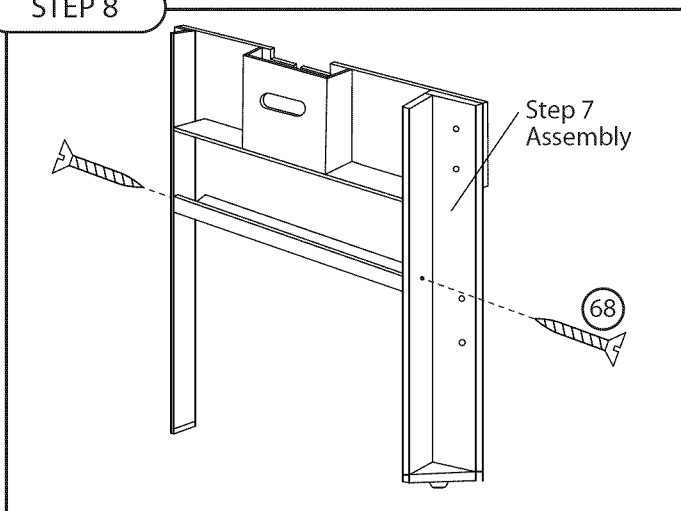

COMPONENTS **QTY.**

Step 7 Assembly	x2
-----------------	----

NOTES

Repeat for both ends.

HARDWARE **QTY.**

(68) Screw - Wood - 4 x 44.5mm	x4
--------------------------------	----

STEP 9

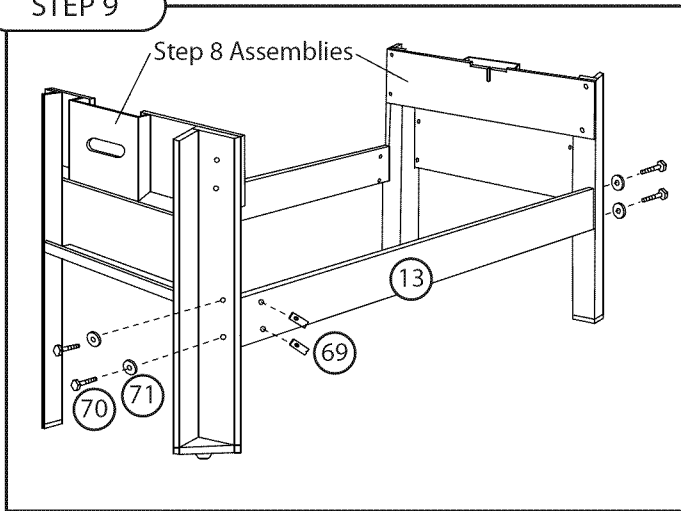

COMPONENTS

COMPONENTS	QTY.
Step 8 Assembly	x2
13 Leg - Side Panel	x2

HARDWARE

HARDWARE	QTY.
69 Barrel Nut - 8mm	x8
70 Bolt - Hex Head - 8 x 63.5mm	x8
71 Washer - Metal - 8mm	x8

NOTE:

Make sure hole in barrel nut is facing the bolt.

Otherwise it will not go in all the way.

Repeat for both sides.

STEP 10

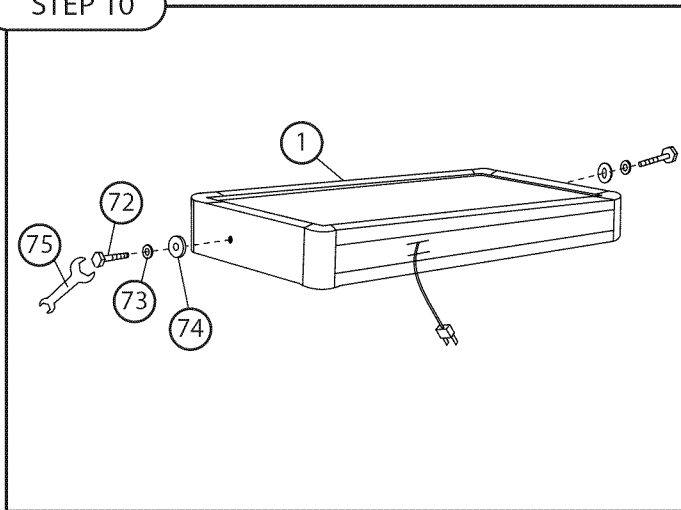

COMPONENTS

COMPONENTS	QTY.
1 Table Top - Cabinet	x1

HARDWARE

HARDWARE	QTY.
72 Bolt - Hex - 12mm	x2
73 Washer - Metal - 12mm	x2
74 Washer - Molded - 12mm	x2
75 Wrench - Hex	x1

NOTE:

Repeat for both ends.

STEP 11

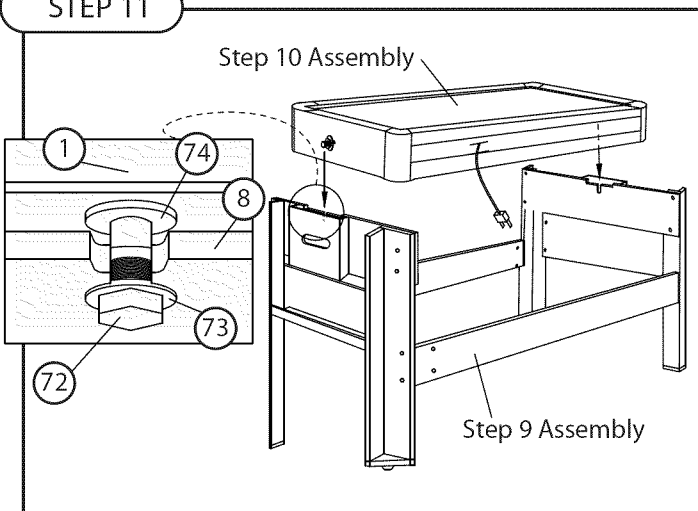

COMPONENTS

COMPONENTS	QTY.
Step 9 Assembly	x1
Step 10 Assembly	x1

NOTES

Open Lock Pins.

Then gently set the playfield assembly in the frame.

Be sure to do it evenly.

When complete, engage all 4 Lock Pins.

STEP 12

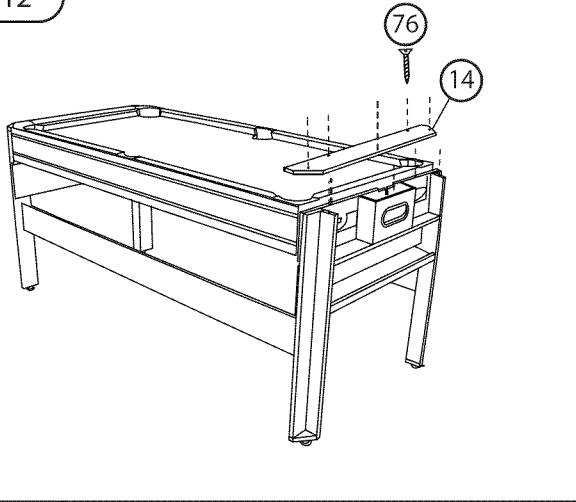

COMPONENTS **QTY.**

Step 11 Assembly	x1
(14) Top End Panel	x2

HARDWARE **QTY.**

(76) Screw - Wood - 4 x 44.5mm	x10
--------------------------------	-----

NOTE:

Repeat for both ends.

Do not over tighten.

STEP 13

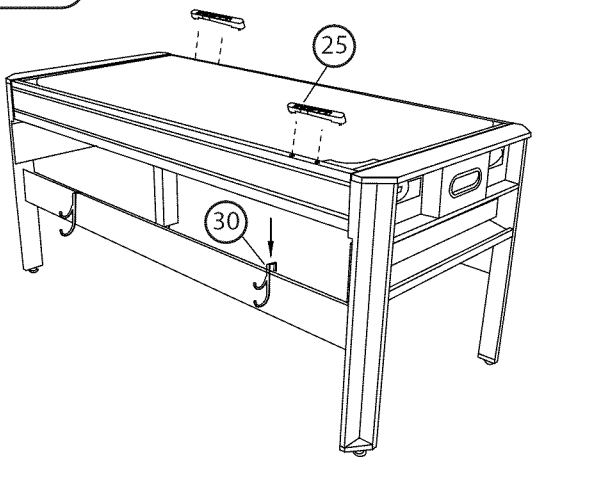

COMPONENTS **QTY.**

Step 12 Assembly	x1
(25) Hockey Scorer	x2
(30) Cue Hook	x2

NOTE:

To complete this step, the hockey side must be facing up.

If not, disengage all 4 Lock Pins, Swivel, then re-engage all 4 Lock Pins.

STEP 14

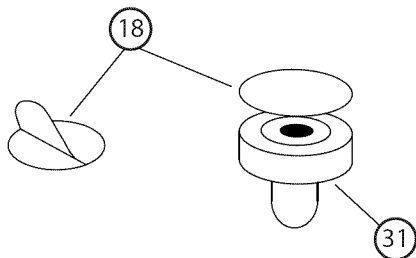

COMPONENTS **QTY.**

(18) Pusher Felt	x2
(31) Pusher - Sombrero	x2

NOTES

Peel back felt and apply evenly to bottom of Pushers.

Limited Warranty

As described in and as limited by this Limited Warranty, EastPoint Sports, Ltd. (the "Company") warrants this Swivel Table (the "Product") to be free from defects in workmanship and materials for a period of 90 days from the date of original purchase. The term defects shall mean any imperfections that impair the use of the product. The Company reserves the right to request confirmation of Proof of Purchase when requesting parts or service in order to confirm that the game is within its warranty period.

What is Covered: Except as provided herein, this Limited Warranty covers all defects in materials and workmanship. This Limited Warranty is void if the Product is:

- Damaged through improper usage or storage, negligence, misuse, abuse, transportation damage, acts of nature, or accident (including failure to follow the instructions supplied with the product)
- Used in commercial applications, rentals or a commercial environment
- Modified or repaired by anyone not authorized by the Company

What is Not Covered:

The Limited Warranty does not cover:

- Expendable items such as cosmetic parts, game playing accessories, and any other items that may show signs of wear due to normal usage
- Any transportation/delivery/installation costs incurred by the Consumer (either home from the original place of purchase or back to the original place of purchase)

What the Company Will Pay For:

- If any part or component of the Product which is covered by this Limited Warranty is found by the Company to be defective, the Company will provide replacement parts without charge. The Company's obligation to repair or replace the Product or any portion thereof, shall be limited to the original purchase price of the product.
- If during the Limited Warranty period, the product is found to be defective, the Company will, at the Company's option, repair, replace, or make remuneration for the Product (either the same or equivalent value) without charge.

How to Obtain Warranty Service: In order to enforce your rights under this Limited Warranty, you must follow these procedures:

- You must return the ORIGINAL COPY OF YOUR SALES RECEIPT to the Company.
- You must call the Company's Consumer Service Department at 1-973-585-4747 or toll free at 1-877-279-7071 on Monday through Friday between the hours of 9:00 A.M. and 5:00 P.M (EST) to notify the Company of the nature of the problem. At the Company's option, replacement parts or a new Product (either the same or equivalent value) will be sent to you at no charge.
- If you are instructed to return the Product to the Company for servicing, you are responsible for shipping the Product, at your expense, to the address designated by the Company in packaging that will protect against further damage.
- You must also include your name, address, daytime telephone number, Product model number, and a description of the problem.
- The Company will pay for any shipping charges to return the repaired or replaced Product to you.

THIS LIMITED WARRANTY IS AVAILABLE ONLY TO THE ORIGINAL PURCHASER OF THE PRODUCT AND IS VALID ONLY IN THE UNITED STATES. THE COMPANY'S LIABILITY IS LIMITED TO THE REPAIR, REPLACEMENT, OR REMUNERATION, AT ITS OPTION, OF ANY DEFECTIVE PRODUCT AND SHALL NOT INCLUDE ANY LIABILITY FOR INDIRECT, INCIDENTAL, OR CONSEQUENTIAL DAMAGES OF ANY KIND. THIS WARRANTY IS EXPRESSLY MADE IN LIEU OF ALL OTHER WARRANTIES, EXPRESSED OR IMPLIED, INCLUDING BUT NOT LIMITED TO THE IMPLIED WARRANTY OF MERCHANTABILITY AND THE IMPLIED WARRANTY OF FITNESS FOR A PARTICULAR PURPOSE. SOME STATES DO NOT ALLOW LIMITATIONS ON HOW LONG AN IMPLIED WARRANTY LASTS OR DO NOT ALLOW FOR EXCLUSION OF INCIDENTAL OR CONSEQUENTIAL DAMAGES. TO THAT EXTENT, THE ABOVE LIMITATIONS MAY NOT APPLY TO YOU.

This Limited Warranty gives you specific legal rights, but you may also have other rights that vary from state to state.

If you have any questions regarding this Limited Warranty or the operation of the Product, you may call or write us.

ALL WARRANTY CLAIMS MUST BE ACCOMPANIED BY A COPY OF THE SALES RECEIPT/PROOF OF PURCHASE. REPORT ANY DEFECTS TO:



628 ROUTE 10, SUITE #5 WHIPPANY, NEW JERSEY 07981 • 1-973-585-4747

TABLE MAINTENANCE AND CARE

Table Top –

- It is OK to gently vacuum the felt side of the billiard table with any standard handheld vacuum brush attachment.
- If Hockey or Table Tennis side needs to be cleaned, you can use any gentle surface cleaner (no bleach or ammonia) with a lint free cloth.
NOTE: DO NOT spray the cleaning product directly on the table surface. It must be applied to the cloth directly. Then the table top can be wiped in a lengthwise direction

Pucks -

- If a puck is rough or not gliding smoothly on top of the table surface, gently sand off the scuff marks with fine grit sandpaper.

Speed -

- If faster puck speed is desired, it is OK to use a wax or oil based cleaner to “slicken” the surface.
NOTE: DO NOT OVER APPLY. A little goes a long way.
NOTE: DO NOT spray the cleaning product directly on the table surface. It must be applied to the cloth directly and then the table top can be wiped in a lengthwise direction.



www.eastpointsports.com