



SAMSUNG

User Manual

High Definition Digital Camcorder



www.samsung.com/register

For video recording, use a memory card that supports faster write speeds.

- Memory Card: A Class 6 SDHC card or above.

HMX-Q10BN/HMX-Q100BN/HMX-Q130BN
HMX-Q10TN/HMX-Q100TN/HMX-Q130TN
HMX-Q10UN/HMX-Q100UN/HMX-Q130UN
HMX-Q10PN/HMX-Q100PN/HMX-Q130PN

Important safety instructions

| | | |
|---|---|---|
|  | CAUTION RISK OF ELECTRIC SHOCK DO NOT OPEN |  |
| CAUTION: TO REDUCE THE RISK OF ELECTRIC SHOCK, DO NOT REMOVE COVER (OR BACK). NO USER-SERVICEABLE PARTS INSIDE REFER SERVICING TO QUALIFIED SERVICE PERSONNEL. | | |

| | |
|--|---|
|  | This symbol indicates that dangerous voltage consisting a risk of electric shock is present within this unit. |
|--|---|

| | |
|--|---|
|  | This symbol indicates that there are important operating and maintenance instructions in the literature accompanying this unit. |
|--|---|

Warning

To Reduce The Risk Of Fire Or Electric Shock, Do Not Expose This Apparatus To Rain Or Moisture.

Caution

Apparatus shall not be exposed to dripping or splashing and no objects filled with liquids, such as vases, shall be placed on the apparatus.

To disconnect the apparatus from the mains, the plug must be pulled out from the mains socket, therefore the mains plug shall be readily operable.

- 1 Read these instructions.
- 2 Keep these instructions.
- 3 Heed all warnings.

- 4 Follow all instructions.
- 5 Do not use this apparatus near water.
- 6 Clean only with dry cloth.
- 7 Do not block any ventilation openings. Install in accordance with the manufacturer's instructions.
- 8 Do not install near any heat sources such as radiators, heat registers, stoves, or other apparatus (including amplifiers) that produce heat.
- 9 Do not defeat the safety purpose of the polarized or grounding-type plug. A polarized plug has two blades with one wider than the other. A grounding type plug has two blades and a third grounding prong. The wide blade or the third prong are provided for your safety. If the provided plug does not fit into your outlet, consult an electrician for replacement of the obsolete outlet.
- 10 Protect the power cord from being walked on or pinched particularly at plugs, convenience receptacles, and the point where they exit from the apparatus.
- 11 Only use attachment/accessories specified by the manufacturer.
- 12 Use only with the cart, stand, tripod, bracket, or table specified by the manufacturer, or sold with the apparatus. When a cart is used, use caution when moving the cart/apparatus combination to avoid injury from tipover.
- 13 Unplug this apparatus during lightning storms or when unused for long periods of time.



Important safety instructions

14 Refer all servicing to qualified service personnel. Servicing is required when the apparatus has been damaged in any way, such as powersupply cord or plug is damaged, liquid has been spilled or objects have fallen into the apparatus, the apparatus has been exposed to rain or moisture, does not operate normally, or has been dropped.

15. Apparatus shall not be exposed to dripping or splashing and no objects filled with liquids, such as vases, shall be placed on the apparatus.

16. VENTILATION:

Slots and openings in the cabinet are provided for ventilation to ensure reliable operation of the CAMCORDER and to protect it from overheating. These openings must not be blocked or covered. Never place your CAMCORDER on a bed, sofa, rug, or other similar surface: on or near a radiator or heat register. This CAMCORDER should not be placed in a built-in installation such as a bookcase or rack unless proper ventilation is provided or the manufacturer's instructions have been adhered to.

17. POWER SOURCES:

The CAMCORDER should be operated only from the type of power source indicated on the label. If you are not sure of the type of power supply at your home, consult your appliance dealer or local power company. A CAMCORDER is intended to be operated from battery power, or other sources, refer to the operating instructions.

18. GROUNDING OR POLARIZATION:

This CAMCORDER may be equipped with either a polarized 2-wire AC line plug (a plug having one blade wider than the other) or a 3-wire grounding type plug, a plug having a third (grounding) pin. If you are unable to insert the plug fully into the

outlet, try reversing the plug. If the plug still fails to fit, contact your electrician to replace your outlet. Do not defeat the safety purpose of the polarized plug.

19. POWER-CORD PROTECTION:

Power-supply cords should be routed so that they are not likely to be walked on or pinched by items placed upon or against them, paying particular attention to cords or plugs, convenient receptacles, and the point where they exit from the unit.

20. OUTDOOR ANTENNA GROUNDING:

CAMCORDER, be sure the antenna or cable system is grounded to provide some protection against voltage surges and built-up static charges, Section 810 of the National Electrical Code, ANSI/NFPA No. 70-1984, provides information with respect to proper grounding of the mast and supporting structure, grounding of the lead-in wire and supporting structure, grounding of the mast and supporting structure, grounding of the lead-in wire to an antenna discharge unit, size of grounding to conductors, location of antenna-discharge unit, connection to grounding electrodes and requirements for the grounding electrode. See figure below.

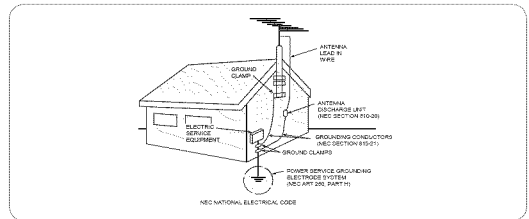

21. LIGHTNING:

For added protection of this CAMCORDER during a lightning storm or when it is left unattended and unused for long periods of time, unplug it from the wall outlet and disconnect the antenna or cable system. This will prevent damage to the CAMCORDER due to lightning and powerline surges.

22. POWER LINES:

An outside antenna system should not be located in the vicinity of overhead power lines or other electric light or power circuits where it can fall into such power lines or circuits. When installing an outside antenna system, extreme care should be taken to keep from touching such power lines or circuits as contact with them might be fatal.

23. OVERLOADING:

Do not overload wall outlets and extension cords as this can result in a risk of fire or electric shock.

24. OBJECTS AND LIQUIDS:

Never push objects of any kind into this CAMCORDER through openings as they may touch dangerous voltage points or short out a part that could result in a fire or electric shock. Never spill liquids of any kind onto the CAMCORDER. Should spillage occur, unplug unit and have it checked by a technician before use.

25. SERVICING:

Do not attempt to service this CAMCORDER yourself. Opening or removing covers may expose you to dangerous voltage or other hazards. Refer all servicing to qualified service personnel.

26. DAMAGE REQUIRING SERVICE:

Unplug this CAMCORDER from the wall outlet and refer servicing to qualified service personnel under the following conditions:

- a. When the power-supply cord or plug is damaged.
- b. If any liquid has been spilled onto, or objects have fallen into the CAMCORDER.
- c. If the CAMCORDER has been exposed to rain or water.
- d. If the CAMCORDER does not operate normally by following the operating instructions, adjust only those controls that are covered by the operating instructions. Improper adjustment of other controls may result in damage and will often require extensive work by a qualified technician to restore the CAMCORDER to its normal operation.
- e. If the CAMCORDER has been dropped or the cabinet has been damaged.
- f. When the CAMCORDER exhibits a distinct change in performance, this indicates a need for service.

27. REPLACEMENT PARTS:

When replacement parts are required, be sure the service technician has used replacement parts specified by the manufacturer and having the same characteristics as the original part. Unauthorized substitutions may result in fire, electric shock or other hazards.

28. SAFETY CHECK:

Upon completion of any service or repairs to this CAMCORDER, ask the service technician to perform safety checks to determine that the CAMCORDER is in safe operating order.

29. To prevent damage which may result in fire or shock hazard, do not expose this appliance to rain or moisture.

30. If this power supply is used at 240V ac, a suitable plug adaptor should be used.

Important safety instructions

USER INSTALLER CAUTION:

Your authority to operate this FCC certified equipment could be voided if you make changes or modifications not expressly approved by this party responsible for compliance to part 15 FCC rules.

NOTE:

(Hg) LAMP(S) INSIDE THIS PRODUCT CONTAIN MERCURY AND MUST BE RECYCLED OR DISPOSED OF ACCORDING TO LOCAL, STATE OR FEDERAL LAWS. For details see lamprecycle.org, eiaa.org, or call 1-800-Samsung (7267864)

CALIFORNIA USA ONLY

This Perchlorate warning applies only to primary CR (Manganese Dioxide) Lithium coin cells in the product sold or distributed **ONLY** in California USA. Perchlorate Material - special handling may apply, See www.dtsc.ca.gov/hazardouswaste/perchlorate.

NOTE:

This equipment has been tested and found to comply with the limits for a Class B digital device, pursuant to part 15 of the FCC Rules.

These limits are designed to provide reasonable protection against harmful interference in a residential installation. This equipment generates, uses and can radiate radio frequency energy and, if not installed and used in accordance with the instructions, may cause harmful interference to radio communications. However, there is no guarantee that interference will not occur in a particular installation.

If this equipment does cause harmful interference to radio or television reception, which can be determined by turning the equipment off and on, the user is encouraged to try to correct the interference by one or more of the following measures:

- Reorient or relocate the receiving antenna.
- Increase the separation between the equipment and receiver.
- Connect the equipment into an outlet on a circuit different from that to which the receiver is connected.
- Consult the dealer or an experienced radio/TV technician for help and for additional suggestions. The user may find the following booklet prepared by the Federal Communications Commission helpful: "How to Identify and Resolve Radio-TV Interference Problems." This Booklet is available from the U.S. Government Printing Office, Washington, D.C. 20402, Stock No. 004-000-00345-4.

FCC Warning





The user is cautioned that changes or modifications not expressly approved by the manufacturer could void the user's authority to operate the equipment. This device complies with Part 15 of FCC Rules. Operation is subject to the following two conditions;

- (1) This device may not cause harmful interference, and
- (2) This device must accept any interference received, including interference that may cause undesired operation.

Before reading this user manual

SAFETY WARNINGS

What the icons and signs in this user manual mean;

| Safety Icon | Meaning |
|--|---|
|  WARNING | There is a potential risk of death or serious injury. |
|  CAUTION | There is a potential risk of personal injury or damage to the product. |
|  | To reduce the risk of fire, explosion, electric shock, or personal injury when using your camcorder, follow these basic safety precautions. |
|  | Here are hints or page number references you will find helpful when you operate the camcorder. |
|  | Settings required before using a function. |

These warning signs are here to prevent injury to you and others. Please follow them explicitly. After reading this section, keep it in a safe place for future reference.

PRECAUTIONS

Warning!

- When using the AC power adapter with your camcorder, connect the adapter to an outlet with protective grounding.
- Do not expose the camcorder battery to direct sunlight, heaters, radiators, fire, or any other source of excessive heat.

Caution

If you replace the battery with the wrong battery, you can cause an explosion. Replace only with the same battery or an equivalent type.

If you plug the AC adapter into a 240V AC outlet, be sure to use a suitable plug adapter.

IMPORTANT INFORMATION ON USE

About this user manual

Thank you for purchasing this Samsung Camcorder. Please read this user manual carefully before you use the camcorder and keep it handy for future reference. Should your camcorder fail to operate correctly, refer to Troubleshooting.

This User Manual covers HMX-Q10BN, HMX-Q10TN, HMX-Q10UN, HMX-Q10PN, HMX-Q100BN, HMX-Q100TN, HMX-Q100UN, HMX-Q100PN, HMX-Q130BN, HMX-Q130TN, HMX-Q130UN, HMX-Q130PN models.

- Illustrations of model HMX-Q10BN are used in this user manual.
- The displays in this user manual may not be exactly the same as those you see on the LCD screen.
- Designs and specifications of the camcorder and other accessories are subject to change without any notice.
- In this user manual, the icon or symbol in the parenthesis appearing in a description of a submenu item indicates it will appear on the screen when setting the corresponding item.
Ex) Submenu item of **"Video Resolution"** ▶ page 63
- **"Full HD 1080/60i"** (フルHD): Records in the Full HD (1920x1080/60i) format. (If set, the corresponding icon (フルHD) will appear on the screen.)

The following terms are used in this manual:

- 'Scene' refers to the point where you press the **Recording Start/Stop** button to start recording until you press again to stop the recording.
- The terms 'photo' and 'still image' are used interchangeably and have the same meaning.

Before using this camcorder

- **This camcorder records video in H.264 (MPEG4/AVC) format.**
- **You can play back and edit the video recorded by the camcorder on a personal computer using the internal software of this camcorder.**
- **Please note that this camcorder is not compatible with other digital video formats.**
- **Before recording important video, make a trial recording.**
Play back your trial recording to make sure the video and audio have been recorded properly.
- **Recorded contents may be lost due to a mistake when handling the camcorder or memory card, etc.**
Samsung will not provide compensation for damages due to the loss of recorded contents.
- **Make a backup of important recorded data.**
Protect your important recorded data by copying the files to a PC. We also recommend you copy them from your PC to other recording media for storage. Refer to the software installation and USB connection guide.
- **Copyrights: Please note that this camcorder is intended for individual use only.**
Data recorded on the storage media in this camcorder using other digital/analog media or devices is protected by the Copyright Act and cannot be used without permission of the owner of the copyright, except for personal enjoyment. Even if you record an event such as a show, performance, or exhibition for personal enjoyment, we strongly recommend that you obtain permission beforehand.
- For Open Source licenses information, refer to the "Opensource-Q10.pdf" in the provided CD-ROM.

Notes regarding trademarks

- All the trade names and registered trademarks mentioned in this manual or other documentation provided with your Samsung product are trademarks or registered trademarks of their respective holders. Furthermore, "™" and "®" are not mentioned in each case in this manual.
- The SD logo is a trademark. The SDHC logo is a trademark.
- Microsoft®, Windows®, Windows Vista®, Windows® 7, and DirectX® are either registered trademarks or trademarks of the Microsoft Corporation in the United States and/or other countries.
- Intel®, Core™, Core 2 Duo®, and Pentium® are the registered trademarks or trademarks of the Intel Corporation in the United States and other countries.
- AMD and Athlon™ are either registered trademarks or trademarks of AMD in the United States and other countries.
- Macintosh, Mac OS are either registered trademarks or trademarks of Apple Inc. in the United States and/or other countries.
- YouTube is a trademark of Google Inc.
- Flickr is a trademark of Yahoo.
- Facebook is a trademark of Facebook Inc.
- twitter is a trademark of twitter Inc.
- Picasa is a trademark of Google Inc.
- HDMI, the HDMI logo and High-Definition Multimedia Interface are trademarks or registered trademarks of HDMI Licensing LLC.
- Adobe, the Adobe logo, and Adobe Acrobat are either registered trademarks or trademarks of Adobe Systems Incorporated in the United States and/or other countries.

Safety information

The safety precautions illustrated below are to prevent personal injury or material damages. Heed all instructions carefully.



WARNING

There is a potential risk of death or serious injury.



CAUTION

There is a potential risk of personal injury or damage to the product.



Prohibited action.



Do not touch the product.



Do not disassemble the product.



This precaution must be followed.



Unplug from the power supply.

! WARNING



Do not overload outlets or extension cords as this may result in abnormal heat or fire.

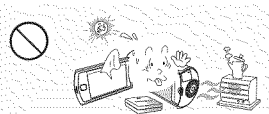

Using the camcorder at temperatures over 60°C (140 °F) may result in fire. Keeping the battery at a high temperature may cause an explosion.

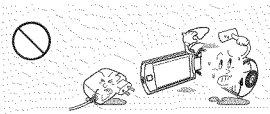

Do not allow water or metal and inflammable matter to enter the camcorder or AC power adaptor. Doing so may pose a fire hazard.

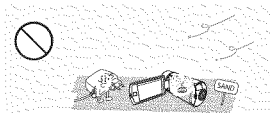

No sand or dust! Fine sand or dust entering the camcorder or AC power adaptor could cause malfunctions or defects.



No oil! Oil entering the camcorder or AC power adaptor could cause electric shock, malfunctions or defects.

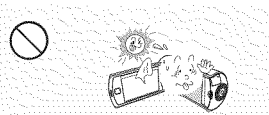

Do not aim the camcorder directly into the sun. Doing so could cause eye injuries, as well as lead to malfunctioning of internal parts of the product.

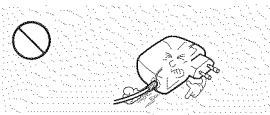

Do not bend the power cord or damage the AC power adaptor by pressing on it with a heavy object. There may be a risk of fire or electric shock.

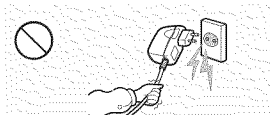

Do not disconnect the AC adaptor by pulling on its power-cord, as this could damage the power-cord.

Safety information



Do not use the AC adaptor if it has damaged, split or broken cords or wires. Doing so may cause fire or electric shock.

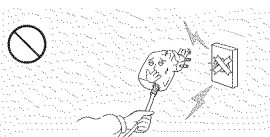

Do not connect the AC adaptor unless the plug can be fully inserted with no part of the blades exposed.

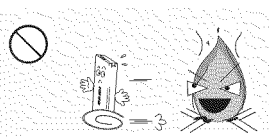

Do not dispose of the battery in a fire as it may explode.

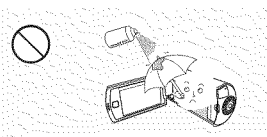

Never use cleaning fluid or similar chemicals to clean the camcorder. Do not spray cleaners directly on the camcorder.

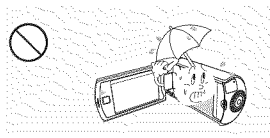

Keep the camcorder away from water when using it near the beach or pool or when it rains. There is a risk of malfunction or electric shock.

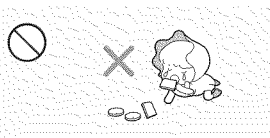

Keep the used lithium battery or memory card out of the reach of children. If the lithium battery or memory card is swallowed by a child, consult physician immediately.

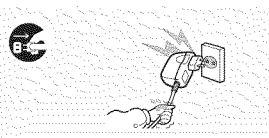

Do not plug or unplug the power cord with wet hands. There is a risk of electric shock.

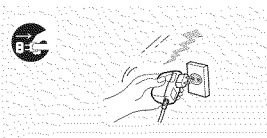

Keep the power-cord unplugged when not in use or during lightning storms. There is a risk of fire.

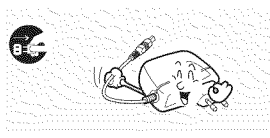

When cleaning the AC adaptor, unplug the power-cord. There is a risk of malfunction or electric shock.

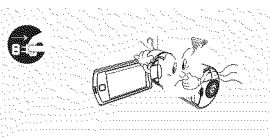

If the camcorder emits an abnormal sound, or smell or smokes, unplug the power-cord immediately and request service from a Samsung service center. There is a risk of fire or personal injury.

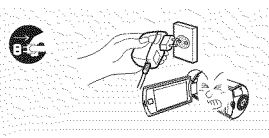

If the camcorder malfunctions, immediately detach the AC adaptor or battery from the camcorder. There is a risk of fire or injury.

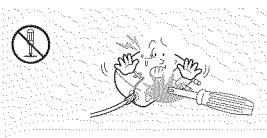

Do not attempt to disassemble, repair, or modify the camcorder or the AC adaptor to avoid a risk of fire or electric shock.

! CAUTION

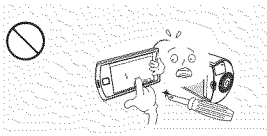

Do not press the surface of the LCD with force, or hit it with a sharp object. If you push the LCD surface, display unevenness may occur.

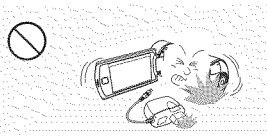

Do not drop or expose the camcorder, battery, AC adaptor, or other accessories to severe vibrations or impact. This may cause a malfunction or injury.

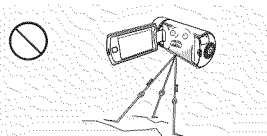

Do not use the camcorder on a tripod (not supplied) in a place where it is subject to severe vibrations or impact.

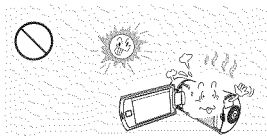

Do not use the camcorder in direct sunlight or near heating equipment. This may cause a malfunction or injury.

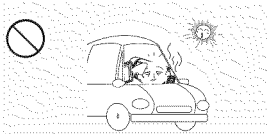

Do not leave the camcorder in a closed vehicle for a long time, where the temperature is very high.

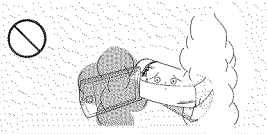

Do not expose the camcorder to soot or steam. Thick soot or steam could damage the camcorder case or cause a malfunction.

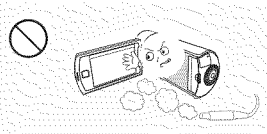

Do not use the camcorder near dense exhaust gas generated by gasoline or diesel engines, or near a corrosive gas such as hydrogen sulfide. Doing so may corrode the external or internal terminals, disabling normal operation.

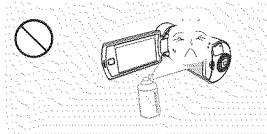

Do not expose the camcorder to insecticide. Insecticide entering the camcorder could cause the product to operate abnormally. Turn the camcorder off and cover it with vinyl sheet, etc. before using insecticide.

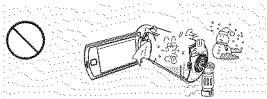

Do not expose the camcorder to sudden changes in temperature or high humidity. There is also a risk of defect or electric shock when using outdoors during lightning storms.

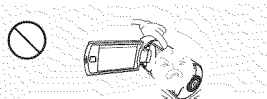

Do not place the camcorder with the open LCD screen down.

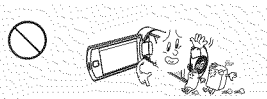

Do not wipe the camcorder body with benzene or thinner. The exterior coating could peel off or the surface could deteriorate.

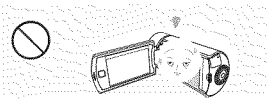

Do not leave the LCD screen open when not using the camcorder.



Do not hold the camcorder by the LCD monitor when lifting it. The LCD screen could detach and the camcorder may fall.

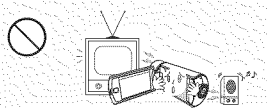

Do not use the camcorder near a TV or radio: This could cause distortion on the TV screen or interference in the radio broadcasts.

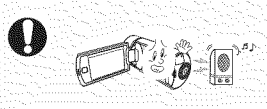

Do not use the camcorder near sources of strong radio waves or magnetism such as speakers or large motors. Noise from these sources could distort the video or audio you are recording.

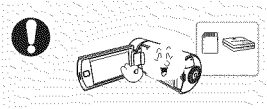

Use Samsung-approved accessories only. Using products from other manufacturers may cause overheating, fire, explosion, electric shock or personal injuries caused by abnormal operation.

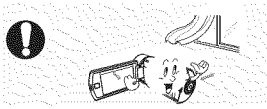

Place the camcorder on a stable surface that is well ventilated.

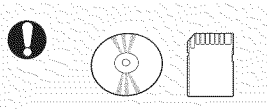

Keep important data separately. Samsung is not responsible for data loss.

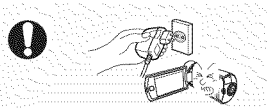

Only plug the adaptor plug into a socket that is easily accessible. If any problem occurs with the product, you must pull the plug out of the socket to disconnect the power completely. Turning off the power button on the product does not completely disconnect the power.

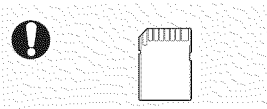

Manufacturers of unauthorized accessories compatible with this camcorder are responsible for their own products. Use the optional accessories according to their safety instructions. Samsung is not responsible for any malfunctions, for fires or electric shocks, or for damage caused by unauthorized accessories.

Contents

| | | | |
|---|----|--------------------------------------|----|
| Quick start guide | 10 | Basic playback | 41 |
| Getting to know the camcorder | 14 | CHANGING THE PLAYBACK MODE | 41 |
| WHAT'S INCLUDED WITH YOUR CAMCORDER | 14 | PLAYING VIDEOS | 42 |
| LOCATION OF CONTROLS | 15 | VIEWING PHOTOS | 45 |
| IDENTIFYING THE SCREEN DISPLAYS | 17 | | |
| Getting started | 21 | Using the menu items | 47 |
| INSERTING/EJECTING THE BATTERY | 21 | HANDLING MENUS | 47 |
| CHARGING THE BATTERY | 22 | MENU ITEMS | 48 |
| CHECKING THE BATTERY STATE | 23 | | |
| Basic operation of the camcorder | 25 | Advanced recordings | 50 |
| TURNING YOUR CAMCORDER ON/OFF | 25 | White Balance | 50 |
| SETTING THE OPERATION MODES | 26 | EV (Exposure Value) | 51 |
| USING THE TOUCH SCREEN | 26 | Back Light | 51 |
| SETTING THE TIME ZONE AND DATE/TIME FOR THE FIRST TIME | 28 | Self Timer | 52 |
| SELECTING THE OSD LANGUAGE | 29 | Super C.Nite | 52 |
| | | Cont. Shot | 53 |
| Getting ready to start recording | 30 | Focus | 53 |
| INSERTING/EJECTING A MEMORY CARD (NOT SUPPLIED) | 30 | | |
| SELECTING A SUITABLE MEMORY CARD (NOT SUPPLIED) | 31 | Special effects for recordings | 54 |
| RECORDABLE TIME AND CAPACITY | 33 | Fader | 54 |
| USING THE GRIP BELT | 34 | Time Lapse REC | 55 |
| ADJUSTING THE LCD SCREEN | 35 | Digital Effect | 57 |
| | | | |
| Basic recording | 36 | Editing videos and photos | 58 |
| RECORDING VIDEOS | 36 | Delete | 58 |
| RECORDING PHOTOS | 38 | Protect | 59 |
| RECORDING WITH EASE FOR BEGINNERS (SMART AUTO) | 39 | Divide | 60 |
| ZOOMING | 40 | Combine | 61 |
| | | File Info | 62 |

| | | | |
|-------------------------|----|---|-----|
| Other settings..... | 63 | Format..... | 77 |
| Video Resolution..... | 63 | Default Set..... | 78 |
| Photo Resolution..... | 63 | Language..... | 78 |
| OLS Duo..... | 64 | Demo..... | 79 |
| Tele Macro..... | 64 | Connecting to a TV..... | 80 |
| Digital Zoom..... | 65 | CONNECTING TO A HIGH DEFINITION TV WITH HDMI..... | 80 |
| Thumbnail..... | 65 | CONNECTING TO A REGULAR TV..... | 81 |
| Video Play Option..... | 66 | VIEWING ON A TV SCREEN..... | 82 |
| Slide Show Option..... | 66 | Dubbing videos..... | 83 |
| LCD Brightness..... | 67 | DUBBING TO A VCR OR DVD/HDD RECORDER..... | 83 |
| Guideline..... | 67 | Printing photos..... | 84 |
| Date/Time Display..... | 68 | DIRECT PRINTING WITH A PICTBRIDGE PRINTER..... | 84 |
| TV Display..... | 68 | Using with a Windows computer..... | 86 |
| HDMI TV Out..... | 69 | WHAT YOU CAN DO WITH A WINDOWS COMPUTER..... | 86 |
| Auto LCD Off..... | 69 | USING THE Intelli-studio PROGRAM..... | 87 |
| PC Software..... | 70 | USING AS A REMOVABLE STORAGE DEVICE..... | 91 |
| USB Connect..... | 70 | Troubleshooting..... | 93 |
| TV Connect Guide..... | 71 | WARNING INDICATORS AND MESSAGES..... | 93 |
| Anynet+ (HDMI-CEC)..... | 71 | SYMPTOMS AND SOLUTIONS..... | 98 |
| Card Info..... | 72 | Additional information..... | 104 |
| File No..... | 72 | MAINTENANCE..... | 104 |
| Time Zone..... | 73 | USING YOUR CAMCORDER ABROAD..... | 105 |
| Date/Time Set..... | 73 | GLOSSARY..... | 106 |
| Date Type..... | 73 | Specifications..... | 107 |
| Time Type..... | 74 | | |
| Beep Sound..... | 74 | | |
| Shutter Sound..... | 75 | | |
| Auto Power Off..... | 75 | | |
| Quick On STBY..... | 76 | | |
| Switch Grip..... | 77 | | |

Quick start guide

This quick start guide introduces the basic operation and features of your camcorder. See the reference pages for more information.

You can record videos in H.264 format!

You can record videos in H.264 format that is convenient to email and share with your friends and family.

You can also take photos with your camcorder.

STEP 1: Get ready

- 1 Insert the battery to the camcorder. **▶**page 21
 - Make sure that the SAMSUNG logo is facing down and the battery is placed as shown in the figure.
- 2 Charge the battery fully. **▶**page 22
 - The battery is fully charged when the charging indicator light turns green.
- 3 Insert a memory card. **▶**page 30
 - You can use commercially available SDHC or SD memory cards with this camcorder.

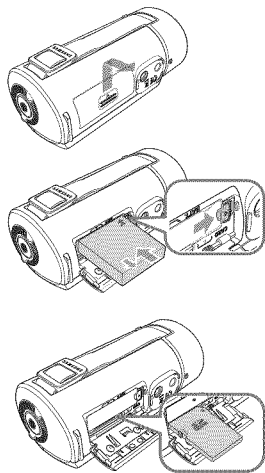

STEP 2: Record with your camcorder

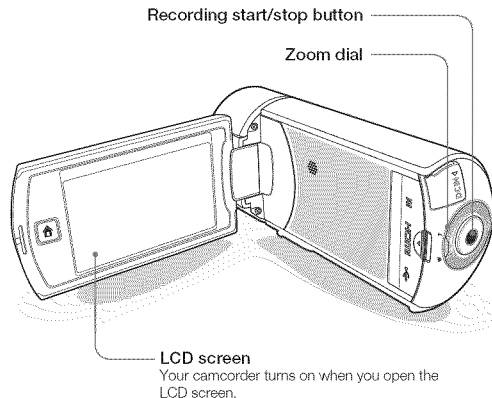

Recording videos

Your camcorder uses advanced H.264 compression technology give you the clearest video quality.

- 1 Open the LCD screen.
- 2 Select the video recording mode by touching the Video recording mode (📹) tab.



- 3 Press the **Recording start/stop** button.
 - To stop recording, press the **Recording start/stop** button.



 The default video resolution setting is "Full HD 1080/60i". You can also record with SD (standard definition) video quality.

Recording photos

Your camcorder can record high quality photos with a 16:9 aspect ratio.

- 1 Open the LCD screen.
- 2 Select the photo recording mode by touching the Photo recording mode (📷) tab.



- 3 Press the **Recording start/stop** button.
 - The shutter sound is heard and the photo is recorded.



Using "Quick On STBY" by opening/closing the LCD screen.

When you close the LCD screen, your camcorder goes to the Quick On STBY mode (power saving mode). You can start recording quickly when you open the LCD screen. ➔ page 76

STEP3: Play back videos or photos

Viewing videos or photos on the LCD screen

You can find recordings quickly by using the thumbnail index view.

- 1 Touch the Playback (⏮) tab on the LCD screen in STBY mode.

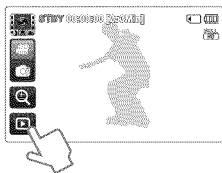

- 2 Touch the thumbnail (⏮/⏭) tab, then touch the desired image.

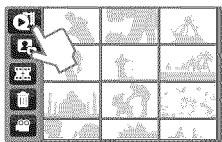

Viewing on a high definition TV

You can enjoy HD (high definition) videos on an HDTV. ➔ page 80



You can also play back videos on a SD (standard definition) image quality TV. ➔ page 81

STEP4: Save recorded videos or photos

Simple and fun! Enjoy the various features of the internal Intelli-studio program on your Windows computer.

Using the Intelli-studio program built into your camcorder, you can import videos/photos into your computer, and edit or share the videos/photos with your friends and family. For details, see pages 86–90

Importing and viewing videos/photos from the camcorder to your PC

- 1 Start the Intelli-studio program by connecting the camcorder to your PC with a USB cable.
 - A new file saving screen appears with the Intelli-studio main window. Click “Yes”, and the uploading procedure starts.

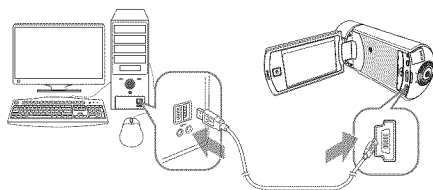

- 2 The new files are saved to your PC and registered to “**Contents Manager**” on the Intelli-studio program.

- You can arrange the files by different criteria such as Face, Date, etc.

Contents Manager Saved files into your PC



Folders directory on your PC

- 3 Double-click on the file you would like to playback.



Sharing videos/photos on Web sites

Share your contents with the world by uploading videos and photos directly to a web site with a single click.
Click “**Share**” → “**Upload**” on the browser. ➔ page 90

-  Intelli-studio runs automatically after you connect your camcorder to a Windows computer if you have set “**PC Software: ON**” in the Settings menu. ➔ page 70

STEP5: Delete videos or photos

If the storage media is full, you cannot record new videos or photos. Delete videos or photos that you have saved to a computer from the camcorder’s storage media. Then you can record new videos or photos on newly freed up space.

Touch the Playback () tab → Delete () tab on the LCD screen. ➔ page 58

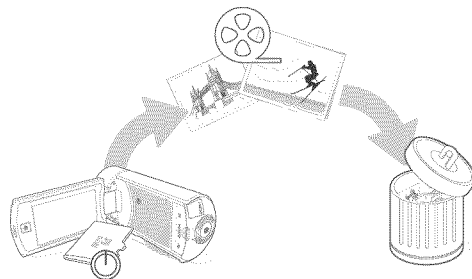

Getting to know the camcorder

WHAT'S INCLUDED WITH YOUR CAMCORDER

Your new camcorder comes with the following accessories. If any of these items is missing from your box, call Samsung's Customer Care Center.

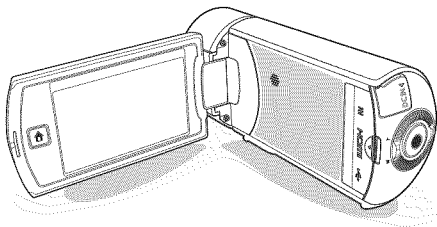

| Model name | Color | Internal memory | Lens |
|-------------------------------------|--------------|-----------------|--------------------------------|
| HMX-Q10BN/HMX-Q100BN/ HMX-Q130BN | Black | No | X10 (Optical) X20 (Digital) |
| HMX-Q10TN/HMX-Q100TN/ HMX-Q130TN | Titan Silver | | |
| HMX-Q10UN/HMX-Q100UN/ HMX-Q130UN | Blue | | |
| HMX-Q10PN/HMX-Q100PN/ HMX-Q130PN | Pink | | |

 Although some features of the models are different, they operate in the same way.

Checking your accessories



Battery
(BP125A)
(AD43-00197A)



AC power adaptor
(AA-MA9)
(AD63-04924A)

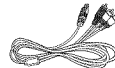

Audio/Video cable
(AD46-00355A)



USB cable
(AD46-00355A)



User manual CD
(AD46-00372A)



Quick start guide
(AD68-05905A)

Optional accessories



Mini HDMI cable
(AD39-00159A)



External battery charger
(IA-BC9UA4)



Carrying case
(AD69-00929A)



Memory card



- The exact appearance of each item may vary by model.
- The contents may vary depending on the sales region.
- Parts and accessories can be purchased after consulting with your local Samsung dealer. SAMSUNG is not responsible for reduced battery life time or malfunctions caused by any unauthorized use of accessories such as the AC power adaptor or the batteries.
- A memory card is not included. See page 31 for memory cards compatible with your camcorder.
- Your camcorder includes the user manual CD and printed quick start guide.

LOCATION OF CONTROLS

Front/Left

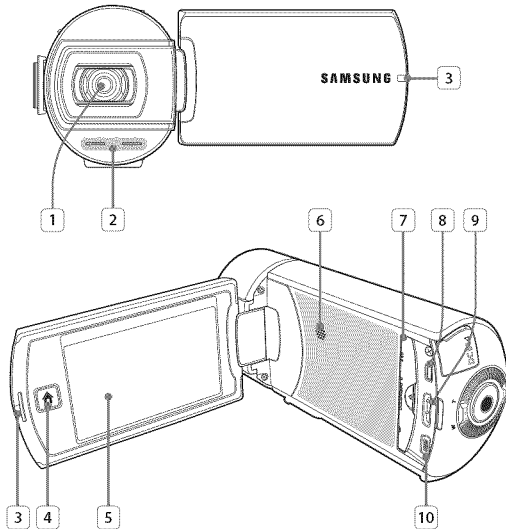

- 1 Lens
- 2 Internal microphone
- 3 Charging indicator
- 4 Home (🏠) button
- 5 LCD screen (Touch screen)
- 6 Internal speaker
- 7 Jack cover (AV/HDMI/USB)
- 8 AV (Audio/Video) jack
- 9 HDMI jack
- 10 USB jack

 Be careful not to cover the internal microphone and lens during recording.

Rear/Right/Bottom

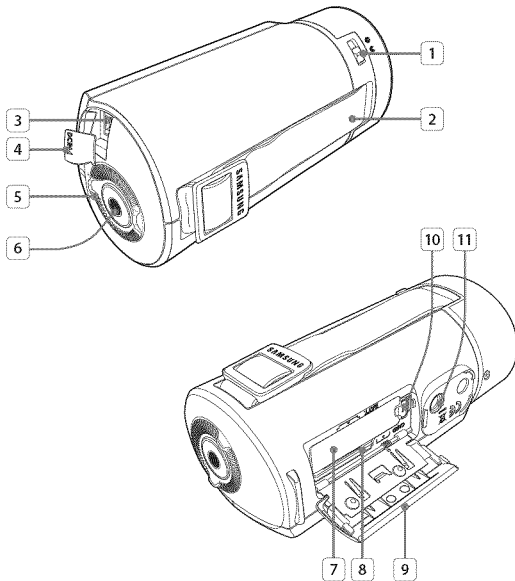

1 Lens open/close switch

2 Grip belt

3 DC IN jack

4 Jack cover (DC IN)

5 Zoom dial

6 Recording start/stop button

7 Battery slot

8 Memory card slot



9 Battery/Memory card cover

10 Battery release switch

11 Tripod receptacle

IDENTIFYING THE SCREEN DISPLAYS





The available functions vary depending on the operation mode you have selected. Different indicators appear depending on the setting values.

-  This On Screen Display (OSD) is shown in the video recording mode only.
- Select the video recording mode.  page 26





Video recording mode









Left of the LCD screen

| Indicator | Meaning |
|---|--|
|  | Smart Auto mode/Manual mode /Art Film mode |
|  | Video/Photo recording mode tab |
|  | Zoom tab |
|  | Playback tab |

Center of the LCD screen

| Indicator | Meaning |
|---|--|
| STBY / ● / ■ | Operating status (standby/recording/pause) |
|  | Time counter (video recording time) |
|  | Remaining recordable time |
|  | Time Zone (Visit) |
|  | Date/Time |

Right of the LCD screen

| Indicator | Meaning |
|---|--|
|  | Storage media (Memory card) |
|  | Battery information (remaining charge level) |
|  | Optical zoom/Digital zoom bar |
|  | Video resolution |
|  | Tele Macro |
|  | OIS Duo |

-  The on-screen indicators are based on an 32GB SDHC memory card capacity.
- The screen above is an example and may differ from the actual display.
- For warning indicators and messages, see pages 93-97
- The illustrated items above and their positions can be changed without notice to improve performance.





-  This On Screen Display (OSD) is shown in the photo recording mode only.
- Select the photo recording mode. [▶ page 26](#)





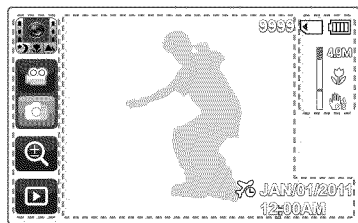

Photo recording mode





Left of the LCD screen

| Indicator | Meaning |
|---|--|
|  | Smart Auto mode/Manual mode /Art Film mode |
|  | Video/Photo recording mode tab |
|  | Zoom tab |
|  | Playback tab |

Right of the LCD screen

| Indicator | Meaning |
|---|--|
|  | Storage media (Memory card) |
|  | Battery information (remaining charge level) |
|  | Optical zoom/Digital zoom bar |
|  | Photo resolution |
|  | Tele Macro |
|  | OIS Duo |

Center of the LCD screen

| Indicator | Meaning |
|---|---|
|  | Photo image counter (total number of recordable photos) |
|  | Time Zone (Visit) |
|  | Date/Time |

-  The total number of recordable photos is based on available space on the storage media.
- The largest number the OSD Image Counter can display is "9,999".



- This On Screen Display (OSD) is shown in the video playback mode only.
- Select the video playback mode. ➔ page 41

Video playback mode : Thumbnail view

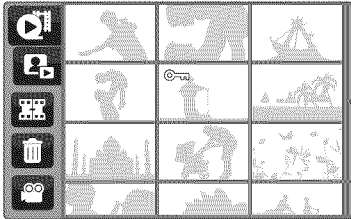

| Indicator | Meaning |
|-----------|--------------------------|
| | Video thumbnail view tab |
| | Photo thumbnail view tab |
| | Combine tab |

| Indicator | Meaning |
|-----------|--------------------------|
| | Delete tab |
| | Video recording mode tab |
| | Erase protection |

Video playback mode: Single view

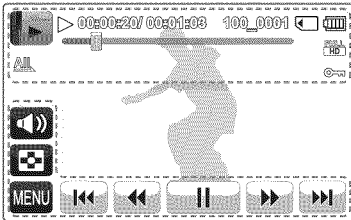

Top of the LCD screen

| Indicator | Meaning |
|-----------|---|
| | Video playback mode |
| | Operating status (playback/pause etc.) |
| | Time code (elapsed time/recorded time) |
| 100_0001 | File name (File number) |
| | Storage media (memory card) |
| | Battery information (remaining battery level) |
| | Playback progress bar |
| | Video resolution |
| | Video playback option |
| | Erase protection |

Bottom of the LCD screen

| Indicator | Meaning |
|-----------|--|
| | Volume tab |
| | Thumbnail view tab |
| | MENU tab |
| | Playback related function tab (skip/search/pause/playback/slow playback/frame by frame playback) |







-  This On Screen Display (OSD) is shown in the photo playback mode only.
- Select the photo playback mode.  page 41

Photo playback mode: Thumbnail view

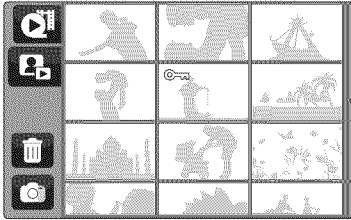

| Indicator | Meaning |
|---|--------------------------|
|  | Video thumbnail view tab |
|  | Photo thumbnail view tab |
|  | Delete tab |









| Indicator | Meaning |
|---|--------------------------|
|  | Photo recording mode tab |
|  | Erase protection |

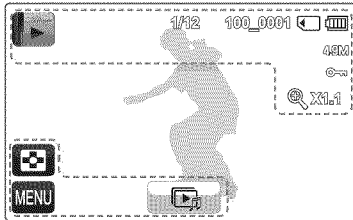

Photo playback mode: Single view



Top of the LCD screen

| Indicator | Meaning |
|---|---|
|  | Photo playback mode |
| 1/12 | Photo image counter (current image/total number of recorded images) |
| 100_0001 | File name (file number) |
|  | Storage media (memory card) |
|  | Battery information (remaining battery level) |
| 4.8M | Photo resolution |
|  | Erase protection |
|  | Playback zoom (X1.1 ~ X8.0) |

Bottom of the LCD screen

| Indicator | Meaning |
|---|----------------------|
|  | Thumbnail view tab |
|  | MENU tab |
|  | Slide show start tab |

Getting started

INSERTING/EJECTING THE BATTERY

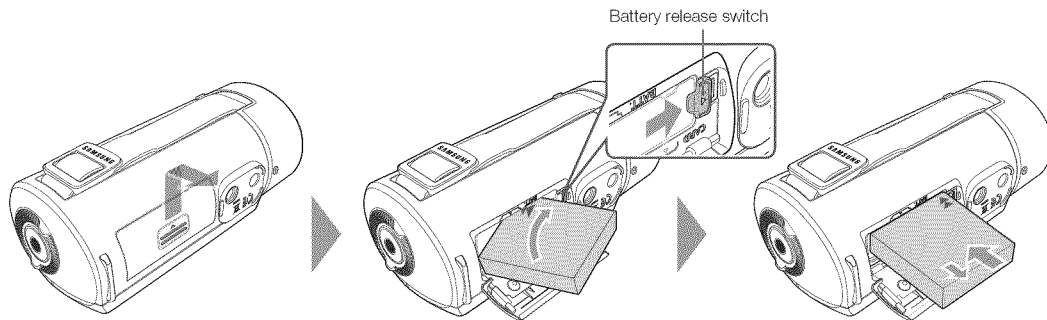

To insert the battery

- 1 Slide and open the battery slot cover as shown in the figure.
- 2 Insert the battery into the battery slot until it locks.
 - Make sure that the SAMSUNG logo is facing down and the battery is placed as shown in the figure.
- 3 Close the battery slot cover.

To eject the battery

- 1 Slide and open the battery slot cover as shown in the figure.
- 2 Slide the Battery release switch in the direction as shown in the figure and pull out the battery.
- 3 Close the battery slot cover.



- Samsung is not responsible for problems that are caused by using unapproved batteries. If you use batteries from other manufacturers, there is a danger of overheating, fire, or explosion.
- Purchase extra batteries to allow continuous use of your camcorder.

CHARGING THE BATTERY

You can charge the battery using the AC power adaptor or the USB cable.

- ✔ Insert the battery into the camcorder. → page 21
- ✔ To charge, use the supplied AC power adaptor or the USB cable.

Charge the battery using the AC power adaptor or the USB cable.

- The charging indicator lights up and charging starts. After the battery is fully charged, the charging indicator turns green.

Using the AC power adaptor

Connect the AC power adaptor to the camcorder properly, and then plug the AC Power adaptor in the wall outlet.

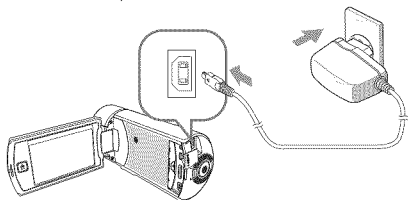

Using the USB cable

Connect the USB cable to the camcorder properly, and then connect the other end to a USB port of a PC.

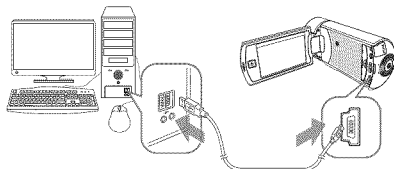

- ⚠ Please make sure that there are no foreign substances on plug and in the socket when you connect the AC power supply to the camcorder.
 - Make sure to turn off the camcorder before disconnecting the AC power adaptor. Otherwise, you can damage the storage media or data.
 - Use a nearby wall outlet when using the AC power adaptor. Disconnect the AC power adaptor from the wall outlet immediately if any malfunction occurs while using your camcorder.
 - Do not place the AC Adaptor in a confined space when you use it, such as between a wall and a piece of furniture.
- ✔ When charging, if both the USB cable and AC power adaptor are connected, the AC power adaptor will override the USB.
 - You cannot operate the camcorder using USB power only. Use the AC power adaptor or battery to power the camcorder.
 - USB charging time may depend on the type of USB host on your PC.
 - If you use the camcorder while you are charging the battery, charging may take longer.
 - Be sure to use the included AC power adaptor to power the camcorder. Using other AC power adaptors could cause electric shock or result in fire.
 - You can use the AC power adaptor around the world. An AC plug adaptor is required in some foreign countries. If you need one, purchase it from your distributor.

CHECKING THE BATTERY STATE

You can check the charging state and remaining battery capacity.

To check the charging state

The color of the LED indicates the power or charging state.

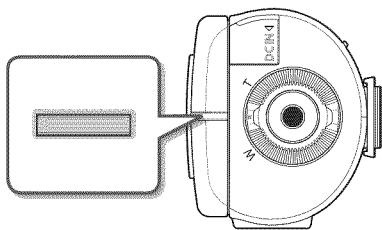

| | |
|----------|---------------|
| (Orange) | Charging |
| (Green) | Fully charged |

Battery level display

The battery level display shows the amount of battery power remaining in the battery.



| Battery level indicator | State | Message |
|-------------------------|---|---------------|
| | Fully charged | - |
| | 25~50% used | - |
| | 50~75% used | - |
| | 75~95% used | - |
| | 95~98% used | - |
| | Exhausted (flickers): The camcorder will be forced to turn off after 3 minutes. Change the battery as soon as possible. | - |
| - | After 3 seconds, the camcorder turns off. | "Low Battery" |



The figures above are based on a fully charged battery at a normal temperature. Low ambient temperature may affect the use time.

Available running time for the battery

| Battery type | BP125A | |
|---------------------------|---|------------------|
| Charging time | Using the AC power adaptor: approx. 120 min. Using the USB cable: approx. 270 min. | |
| Video resolution | Full HD | SD |
| Continuous recording time | Approx. 105 min. | Approx. 120 min. |
| Playback time | Approx. 140 min. | Approx. 160 min. |

- Charging time: Approximate time in minutes required to fully charge a completely exhausted battery.
- Recording/Playback time: Approximate time available when you have fully charged the battery. 'Full HD' stands for high definition image quality and 'SD' stands for standard image quality.
- Times shown above are measured under Samsung's test conditions. Your times may differ, depending on your usage and conditions.
- The recording and playback times will be shorter when you use your camcorder in low temperatures.
- We recommend using the AC power adaptor when using the Time Lapse REC function.



- The charging time will vary depending on the charge remaining in the battery.
- The battery is charged over 95% after about 2 hours, and the indicator color changes to green. It takes about 2 hours and 40 minutes for the battery to charge 100%.

Continuous Recording (without zoom)

The continuous recording time above shows the available recording time when you record without using any other function after recording starts. The battery may discharge 2-3 times faster than this reference if you use the recording start/stop, the zoom, and the playback functions. Prepare additional batteries with the expectation that the actual recording time is about 1/3 to 1/2 of the times listed above.

Using an AC power source

We recommend that you use the AC power adaptor to power the camcorder from a household AC outlet when recording and playing the camcorder indoors. The connection is the same as that for battery charging. ➔page 22

About the battery

Battery Properties

A lithium-ion battery is small-sized and has a high capacity. Low ambient temperature (below 50°F (10°C)) may shorten its usage time and affect its function. Before recording in low temperatures, put the battery into your pocket to warm it, then install it in the camcorder.

Make sure to store the battery separately after use.

- A small amount of battery power is consumed when the battery is stored in the camcorder even if the camcorder power is off.
- The battery may be completely discharged, if it has been installed and left in the camcorder for a long period of time. If this occurs, the battery may not fully operate even if you charge it.
- If the battery is not used for a long time, fully charge the battery and then, using your camcorder, drain the charge completely once every 3 months to keep the battery functioning properly. To store the battery, remove it from your camcorder and put it in a cool, dry place.

Charge an extra battery before using the camcorder outdoors in cold temperatures.

- The cold temperature may shorten the available recording time.
- Carry the supplied AC power adaptor to charge the battery while travelling.

Check whether the battery terminal is damaged if the battery falls or is dropped.

- If you install a battery with the damaged terminal into the camcorder, you can damage the camcorder.

Remove the battery and the memory card from the camcorder and disconnect the AC power adaptor after use.

- Store the battery in a stable, cool and dry place.
(Recommended temperature : 59°F ~ 77°F (15°C~ 25°C), recommended humidity: 40%~ 60%)
- Temperatures that are too high or too low shorten the battery lifetime.
- The battery terminals can become rusty or malfunction if the battery is stored in a smoky or dusty location.

Recycle or dispose of your dead batteries properly.

The battery lifetime is limited.

- Battery capacity decreases over time and through repeated use. If decreased usage time between charges becomes significant, it is probably time to replace the battery with a new one.
- Each battery's life is affected by storage, operating, and environmental conditions.

Basic operation of the camcorder

TURNING YOUR CAMCORDER ON/OFF

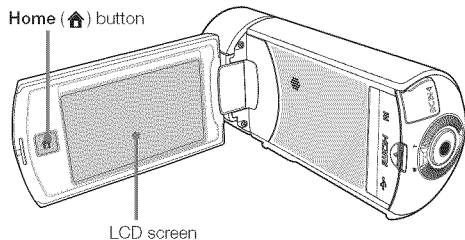

- 1 Turn on the camcorder by opening the LCD screen.
 - Your camcorder turns on automatically when you open the LCD screen.
 - To turn the camcorder on when the LCD screen is already open, close the LCD screen and open it again.
- 2 To turn off the camcorder, press and hold the **Home** (🏠) button or close the LCD screen.



- The camcorder operates the self-diagnosis function when you turn it on. ↪ pages 93-97
- If the Quick On STBY function is set to 5 Min and you close the LCD screen when the power is on, the power saving mode activates. ↪ page 76
- The camcorder turns on automatically if connecting the AC power adaptor or inserting the battery to the camcorder with the LCD screen open.



When using this camcorder for the first time

When you use your camcorder for the first time or reset it, the time zone screen appears at start-up. Select your geographical location and then set the date and time. ↪ page 28
If you do not set the date and time, the time zone screen appears every time you turn on the camcorder.

SETTING THE OPERATION MODES

You can easily switch the operating mode by touching the tabs on the LCD screen.

Switching to the recording mode

In STBY mode, touch the Video recording mode (📹) or Photo recording mode (📷) tab. Touching each tab switches to the respective mode.

- You can also switch directly to the recording mode when pressing the Recording start/stop button in the playback mode.
- You can switch to the desired recording mode by touching "Smart Auto", "Manual", or "Art Film" on the Home menu.

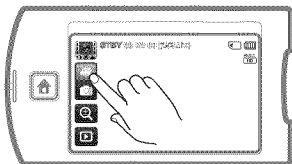

Switching to the playback mode

You can switch to the playback mode by touching "Album" on the Home menu. → page 47

- You can also switch the operation mode directly into the playback thumbnail display by touching the Playback (📺) tab in STBY mode.

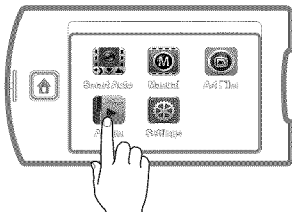

USING THE TOUCH SCREEN

The touch screen lets you playback and recording with a simple touch of your finger. Place your hand on the rear side of the LCD screen to support it. Then, touch the items displayed on the screen.

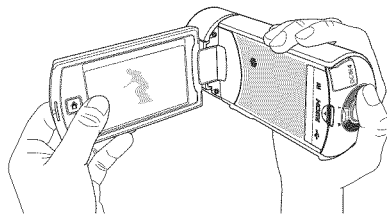

Touch

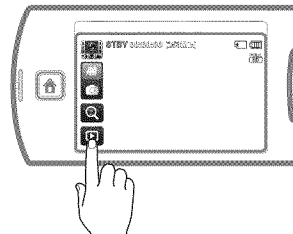

Slightly touch the items to select or execute with your finger.

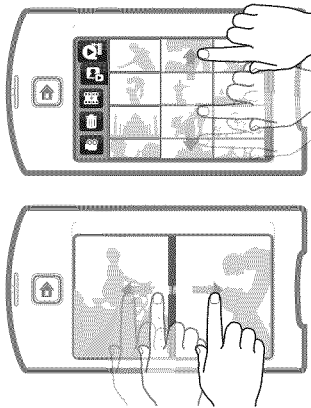

Drag

Drag the touch screen to up, down, left, or right to select the desired items or files.



-  Do not place any protective film on the LCD screen.
-  If you leave a film attached for a long while, strong adhesion between the film and the surface of the screen may cause a malfunction of the touch screen.
-  Be careful not to accidentally press the button near the LCD screen while using the touch screen.
- The tabs and indicators that appear on the LCD screen depend on the current recording/playback status of your camcorder.
- The camcorder does not recognize touches if you touch more than two points on the screen at the same time. Touch one point at a time.

Switching the information display mode

You can switch the on-screen information display mode. Each time you touch the LCD screen, the full and minimum display modes alternate.

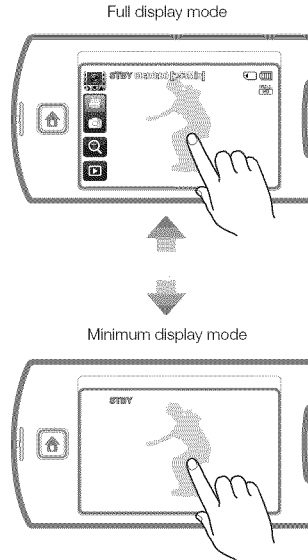

-  Warning indicators and messages may appear, depending on the recording conditions. ▶ pages 93-97

SETTING THE TIME ZONE AND DATE/TIME FOR THE FIRST TIME

Set the date and time of your local area when turning on this camcorder for the first time.

- Open the LCD screen to turn on the camcorder.
 - The time zone (“**Home**”) screen appears based on Lisbon and London (Greenwich Mean Time).
- Select your local area on the map by touching the left (◀) or right (▶) tab on the LCD screen, and then press the (OK) tab.
 - The “**Date/Time Set**” screen appears.



- Set the date by touching the corresponding item or dragging it to up or down.



- Touch the time (⌚) tab, and then set the time by touching the corresponding item or dragging it to up or down.

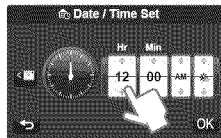

- Make sure the clock is correctly set, and then touch the (OK) tab.
 - The date/time setting finishes.
 - You can set the year up to 2037, based on the “**Home**” item.
 - Set “**Date/Time Display**” to On. ➤page 68
 - Activating the (⌚) icon moves the time forward by 1 hour.



Internal rechargeable battery

- Your camcorder includes an internal rechargeable battery that retains the date and time settings even after the power is turned off.
- If the battery is depleted, the current date/time values are reset to the default values. If this occurs, you need to recharge the internal rechargeable battery (see below), and then re-set the current date and time.

Charging the internal rechargeable battery

- The internal battery is always recharged while your camcorder is connected to the AC power or while the battery is attached.
- If you have not used the camcorder for about 2 weeks and you have not connected the AC power or the battery to it, the internal battery fully discharges. If this occurs, charge the internal battery by connecting the camcorder to the supplied AC adaptor for 24 hours.

SELECTING THE OSD LANGUAGE

You can select the language in which the camcorder displays the menu screen or messages. The camcorder retains the language setting even when you turn it off.

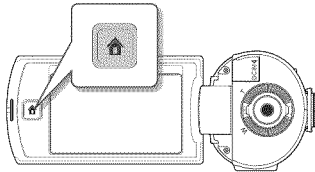

- 1 Press the **Home** (🏠) button → touch **"Settings"** → **"General"**.
 - Drag the LCD screen to up or down until **"General"** appears.
- 2 Touch **"Language"**.
 - Drag the LCD screen to up or down until **"Language"** appears.

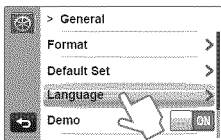

- 3 Touch the desired language.
 - Drag the LCD screen to up or down until the desired language appears.

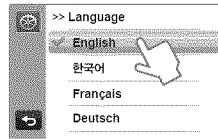

- 4 Touch the Return (↩) tab to complete the setting.
 - The camcorder displays the menus screen and messages in the language you selected.

Supported languages

| | | | | |
|----------|------------|------------|----------|-----------|
| English | 한국어 | Français | Deutsch | Italiano |
| Español | Português | Nederlands | Svenska | Suomi |
| Norsk | Dansk | Polski | Čeština | Slovensky |
| Magyar | Română | Български | Ελληνικά | Srpski |
| Hrvatski | Українська | Русский | 中文 | 日本語 |
| עברית | Türkçe | ایرانی | العربية | עברית |

- **"Language"** options may be changed without prior notice.
- The camcorder retains the language you select even when not connected to the battery or AC power.
- The date and time format may change depending on the language you selected.

Getting ready to start recording

INSERTING/EJECTING A MEMORY CARD (NOT SUPPLIED)

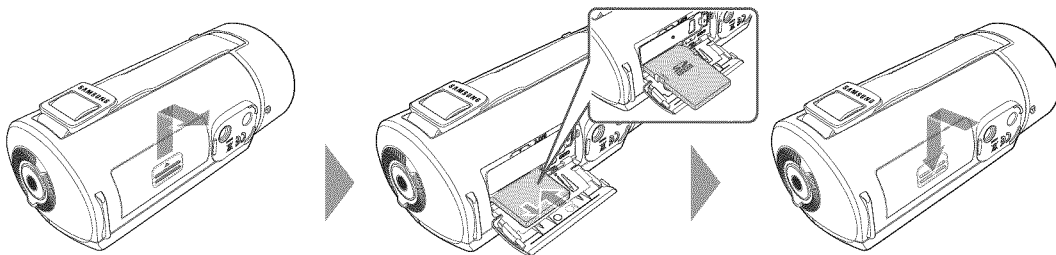

To insert a memory card

- 1 Slide and open the memory card cover as shown in the figure.
- 2 Insert the memory card into the card slot until it softly clicks.
 - Make sure that the terminal portion of the card is facing down and the camcorder is placed as shown in the figure.
- 3 Close the memory card cover.

-  • To avoid the data loss, turn off the camcorder by pressing and hold the **Home** (🏠) button before inserting or ejecting the memory card.
- Be careful not to push the memory card too hard. The memory card may suddenly pop out.

-  Your camcorder supports only SD and SDHC cards.
The compatibility with the camcorder may vary depending on the manufacturer and the type of memory card.

To eject a memory card

- 1 Slide and open the memory card cover as shown in the figure.
- 2 Gently push the memory card to eject it.
- 3 Close the memory card cover.

SELECTING A SUITABLE MEMORY CARD (NOT SUPPLIED)

Compatible memory cards

- This camcorder can be used with SD and SDHC cards. We recommend you use an SDHC card. SD cards up to 2GB are supported by this camcorder. Normal operation is not guaranteed with SD cards bigger than 2GB.
- MMC (Multi Media Card) and MMC Plus are not supported.
- Compatible memory card capacity: SD 1GB ~ 2GB, SDHC 4GB ~ 32GB
- For video recording, use a memory card that supports faster write speeds (above SDHC Class 6 card).
- SD/SDHC memory cards have a mechanical write-protection switch. Setting the switch prevents accidental erasure of files recorded on the card. To enable writing, move the switch up in the direction of the terminals. To set write protection, move the switch down.

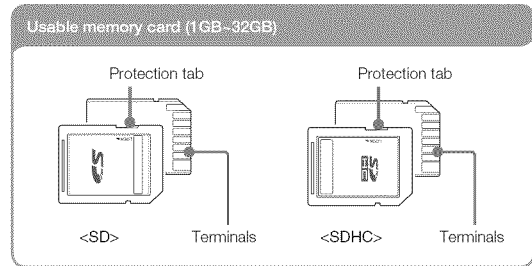

SDHC (Secure Digital High Capacity) cards

- An SDHC card is a higher version (Ver. 2.00) of the SD card and supports capacities above 4GB.
- SDHC cards cannot be used with current SD enabled host devices.

Common cautions for memory cards

- Damaged data may not be recoverable. We recommend you make a back-up of important data separately on the hard disk of your PC.
- Turning the power off or removing a memory card during an operation such as formatting, deleting, recording, and playback may cause data loss.
- After you modify the name of a file or folder stored in the memory card using your PC, your camcorder may not recognize the modified file.

Handling a memory card

- We recommend that you power off the camcorder before inserting or removing the memory card to avoid data loss.
- Make sure to format the memory card on this camcorder. If the memory card had been formatted by a PC or other device, using it on this camcorder without formatting may find trouble with recording and/or playback. Samsung is not responsible for damage of recorded contents caused by such reasons.
- You have to format newly-purchased memory cards, memory cards with data that your camcorder cannot recognize or with data saved by other devices. Note that formatting erases all data on the memory card and deleted data cannot be recovered.
- A memory card has a certain life span. If you cannot record new data, you have to purchase a new memory card.
- Do not bend, drop, or subject the card to strong impacts.
- Do not place foreign substances on the memory card terminals. Use a soft dry cloth to clean the terminals if required.
- Do not paste anything other than the label provided with the card on the label pasting area of the card.
- Do not use a damaged memory card.
- Be careful to keep the memory card out of the reach of children, who might swallow it.

The camcorder supports SD and SDHC memory cards, giving you a wider choice of cards!

The data storage speed may differ, depending on the manufacturer and production system.

- SLC (Single Level Cell) system: faster write speed enabled.
- MLC (Multi Level Cell) system: only lower write speed is supported.

For best results, we recommend using a memory card that supports a faster write speed.

Using a lower write speed memory card for recording video may cause difficulties when storing.

You may even lose your video data during the recording.

In an attempt to preserve every bit of the recorded video, the camcorder forcibly stores the video on the memory card and displays a warning:

"Low speed card. Please record at a lower resolution".

If you are unavoidably using a low speed memory card, the resolution of the recording may be lower than the set value.

▶ page 63

The higher the resolution and quality, the more memory the camcorder uses.



- Samsung is not responsible for data loss due to misuse, including loss caused by any PC virus.
- We recommend using a memory card case to prevent data loss from motion or static electricity.
- After a period of use, the memory card may get warm. This is normal and is not a malfunction.

RECORDABLE TIME AND CAPACITY

Listed below are the available video recording times and the number of photos the camcorder can take, by card memory size and resolution. Refer to the recordable video time and the number of photos when recording videos or taking photos.

Recording time available for video in minutes

| Resolution | Storage media (Capacity) | | | | | |
|------------------|--------------------------|-----|-----|-----|------|------|
| | 1GB | 2GB | 4GB | 8GB | 16GB | 32GB |
| Full HD 1080/60i | 8 | 15 | 30 | 61 | 125 | 253 |
| HD 720/60p | 11 | 21 | 42 | 86 | 177 | 357 |
| SD 480/60p | 32 | 63 | 126 | 254 | 521 | 1051 |

(Unit: Approximate minutes of recording)

Recordable number of photos

| Resolution | Storage media (Capacity) | | | | | |
|----------------|--------------------------|------|------|------|------|------|
| | 1GB | 2GB | 4GB | 8GB | 16GB | 32GB |
| 4.9M 2944X1656 | 931 | 1861 | 3721 | 7440 | 9999 | 9999 |
| 2M 1920X1080 | 1173 | 2346 | 4654 | 9402 | 9999 | 9999 |

(Unit: Approximate number of images)

1GB \approx 1,000,000,000 bytes : Actual formatted capacity may be less as the internal firmware uses a portion of the memory.



- Actual recording times may differ depending on the recording conditions and the subject.
- The higher the quality and resolution, the more memory the camcorder uses.
- Lower resolution and quality increases the recording time, but the image quality may suffer.
- The bit rate automatically adjusts to the image being recorded. Accordingly, the recording time may vary.
- Memory cards bigger than 32GB may not operate normally.
- When a video file exceeds 1.8GB, a new video file is created automatically.
- The maximum number of recordable photo and video files is 9999, respectively.
- The recording length of a Time Lapse REC may vary depending on settings.

USING THE GRIP BELT

Adjust the length of grip belt so that the camcorder is stable when you press the **Recording start/stop** button with your thumb.

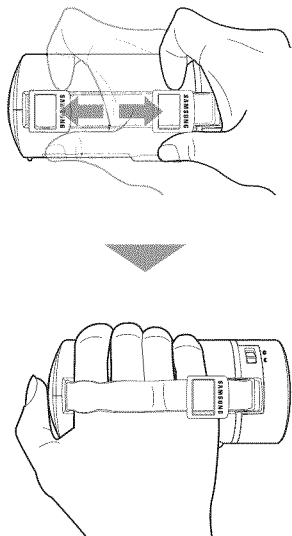

Switch grip (Either handed grip)

The camcorder is designed for you to use conveniently with either your right or left hand. If you want to use this function, set "Switch Grip" to "ON" in the Settings menu. →page 77

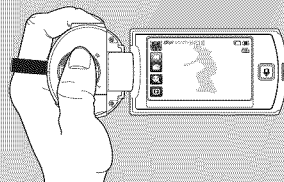

<When you hold the camcorder with your left hand>

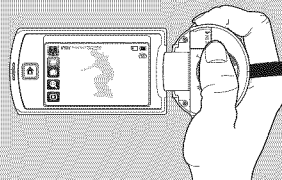

<When you hold the camcorder with your right hand>



If you make the grip belt too tight and use excessive force to insert your hand, the grip belt hook of the camcorder may be damaged.

ADJUSTING THE LCD SCREEN

The wide LCD screen on your camcorder offers high quality image viewing.

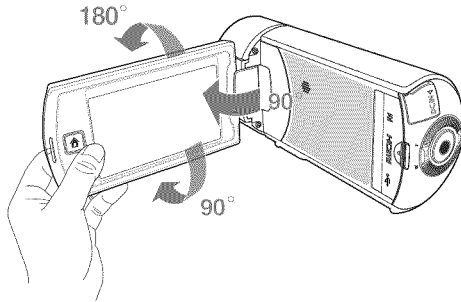

- 1 Open the LCD screen with your finger.
 - The screen opens up to 90°.
- 2 Rotate the LCD screen towards the lens.
 - You can rotate it up to 180° towards the lens and up to 90° backward. To view recordings more conveniently, rotate the screen by 180° towards the lens, then fold it back to the body.

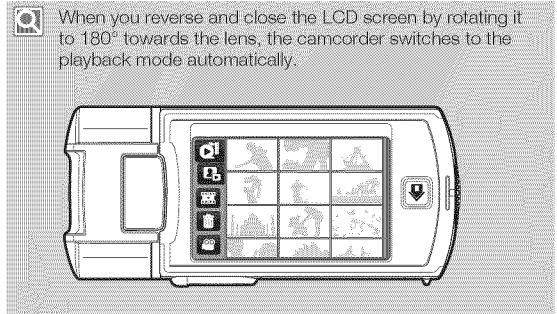

When you reverse and close the LCD screen by rotating it to 180° towards the lens, the camcorder switches to the playback mode automatically.



Excessive rotation may damage the connective hinge between the screen and the camcorder.



Clean fingerprints or dust on the screen with a soft cloth.

Basic recording

RECORDING VIDEOS

This camcorder supports both High Definition (HD) and Standard Definition (SD) image resolutions. Set your desired resolution before recording. ➔page 63

- Insert a memory card. ➔page 30
- Select the video recording mode. ➔page 26
- Open the Lens cover by using the Lens open/close switch. ➔page 16

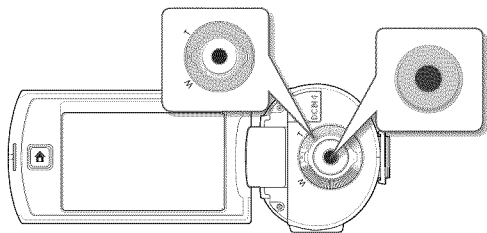

- 1 Select a subject to record.
 - Adjust the LCD screen to the best angle for recording.
 - Use the **Zoom dial** or Zoom (🔍) tab on the LCD screen to adjust the size of the subject. ➔page 40

- 2 Press the **Recording start/stop** button.
 - The recording (●) indicator appears and recording starts.



- 3 To stop recording, press the **Recording start/stop** button again.

 **To pause recording**

The camcorder allows you to pause temporarily while recording a video. With this function, you can record your favorite scenes as a single video.

Touch the Pause (⏸) tab on the LCD screen to pause while recording. Touch the Recording (●) tab to resume.

A screenshot of the camcorder's LCD screen during recording. The screen displays a video preview of a person jumping. A red recording indicator (a solid black circle) is visible in the top left corner. A hand icon is shown pointing to the pause button on the screen. The bottom of the screen shows a playback control bar with a pause button.

- ⚠ If the power is interrupted or an error occurs during recording, the video may not be recorded/edited.
- Samsung is not responsible for any damage caused by a failure of normal recording or playback operation because of memory card error.
- Note that damaged data cannot be recovered.
- Do not turn off the camcorder or remove the memory card while accessing the storage media. Doing so may damage the storage media or the data in the storage media.

- ✍ Videos are compressed in the H.264 (MPEG-4.AVC) format.
- Eject the battery when you have finished recording to prevent unnecessary battery power consumption.
- For the on-screen information display, see page 17
- For approximate recording time, see page 33.
- Sound is recorded by the internal stereo microphone located on the front of the camcorder. Make sure that the microphone is not blocked.
- Before recording an important video, make sure to test the recording function to see if there are any problems with the audio or video recording.
- For various functions available during recording, see pages 50~57
- If the power cable/battery is disconnected or recording is disabled during recording, the system is switched to the data recovery mode. While data is being recovered, no other function is enabled. When the recording time is short, the data recovery might fail.
- You can adjust the brightness of the LCD screen in the menu options. Adjusting the LCD screen does not affect the image being recorded. page 67
- The menu setting tabs shown on the LCD screen do not affect the image being recorded.
- The Home (🏠) button cannot be used during video recording.
- Recording videos in a quiet environment increases microphone sensitivity that may record surrounding ambient noise. The increasing microphone sensitivity can let the camcorder record zoom noises during zooming (the sound of the zoom mechanism etc).
- When you record indoors or in the dark places, ISO sensitivity is automatically adjusted. It can make interference effects on images and you cannot view the images recorded in the dark places correctly. We recommend you to use professional camcorders like a infrared camcorder when recording at night.
- An image can be shaken when the OIS Duo function is enabled if the camcorder is mounted on a tripod or fixed on a place. Release the OIS Duo function when the camcorder is mounted on a tripod.



RECORDING PHOTOS

You can take photos and store them in the storage media. Set the desired resolution before recording. ➔page 63

- ✔ • Insert a memory card. ➔page 30
- Select the photo recording mode. ➔page 26
- Open the Lens cover by using the Lens open/close switch. ➔page 16

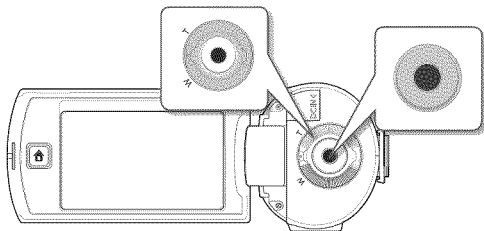

- 1 Select a subject to record.
 - Adjust the LCD screen to the best angle for recording.
 - Use the **Zoom dial** or **Zoom (Z)** tab on the LCD screen to adjust the size of the subject. ➔page 40

- 2 Adjust the subject at the center of the LCD screen, and press the **Recording start/stop** button.

- The shutter sound is heard and the photo is recorded.



- ⚠ Do not turn off the camcorder or remove the memory card when taking photos as it may damage the storage media or data.

- ⚡ • Recordable number of photos varies depending on the photo resolution. ➔page 33
- The camcorder does not record audio when you take photos.
- You can adjust the brightness of the LCD screen in the menu options. Adjusting the LCD screen does not affect the image being recorded. ➔page 67
- For on-screen display information, see page 18.
- For various functions available during recording, see pages 50–57
- Photo files conform to the DCF (Design rule for Camera File system) standard, established by JEITA (Japan Electronics and Information Technology Industries Association.)

RECORDING WITH EASE FOR BEGINNERS (SMART AUTO)

User-friendly SMART AUTO optimizes your camcorder to the recording conditions automatically, providing beginners with the best performance.

- 1 Press the **Home** (🏠) button → touch **"Smart Auto"**.
 - Smart Auto (📷) indicator appears on the LCD screen.

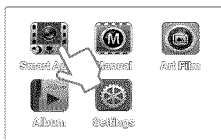

- 2 Align your subject in the frame.
 - The camcorder automatically detects the scene (Landscape, etc.) and adjusts the camcorder settings accordingly.
 - The appropriate scene icon appears on the LCD screen.



| | |
|--|--|
| | Appears when recording at night. (Night) |
| | Appears when recording images of landscapes with backlighting. (Backlight) |
| | Appears when recording people. (Portrait) |
| | Appears when recording a very bright scene. (White) |
| | Appears when recording an outdoor scene. (Landscape) |
| | Appears when recording images using close-up. (Macro) |
| | Appears when recording images of clear skies. (Blue sky) |
| | Appears when recording images of forested areas. (Natural green) |
| | Appears when recording images of sunsets. (Sunset) |

- 3 To record the video or photo, press the **Recording start/stop** button.
- 4 To cancel the Smart Auto mode, press the **Home** (🏠) button → touch **"Manual"**.

- Most settings are automatically adjusted in the Smart Auto mode. To set or adjust functions on your own, select **"Manual"** on the Home menu.
- When the camcorder fails to recognize the recording situations, it records in the basic setting (📷).
- The camcorder may not select the correct scene depending on shooting conditions, such as camcorder shake, lighting, and distance to the subject.
- The camcorder may not detect the portrait mode depending on the orientation or the brightness of faces.

ZOOMING

This camcorder allows you to record using optical X10 zoom and digital zoom by rotating the **Zoom dial** or touching the Zoom (Q) tab on the LCD screen.

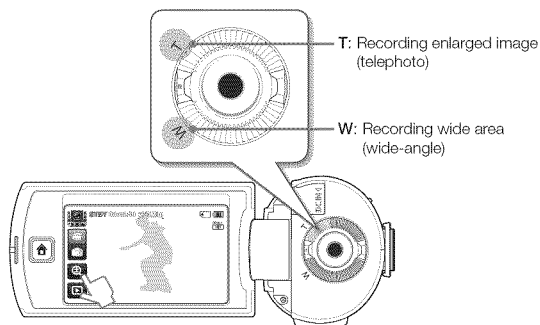

T: Telephoto



W: Wide-angle

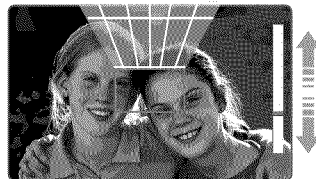

To zoom in

Rotate the **Zoom dial** towards **T** (telephoto). Or touch the Zoom (Q) tab, and then touch the Telephoto (T) tab.

- The distant subject is gradually magnified.
- The highest zoom magnification ratio is X10 in the normal zoom-in.

To zoom out

Rotate the **Zoom dial** towards **W** (wide-angle). Or touch the Zoom (Q) tab, and then touch the Wide-angle (W) tab.

- The subject gets smaller and further away.
- The smallest zoom ratio is the subject's original size in the zoom-out.





- Using the optical zoom does not degrade the image quality and clarity.
- Use the digital zoom when you want to zoom more than the optical zoom range. —page 65
- Focusing may become unstable when you record with a fast zoom or zoom into a subject standing too far away. If this occurs, use the manual focus function. (Video recording mode only) —page 53
- The minimum distance you can have between the camcorder and subject while maintaining sharp focus is about 1cm (about 0.4 inches) for wide angle and about 1m (about 40 inches) for telephoto. If you want to shoot the subject close to the lens at a wide angle, use the Tele Macro function. —page 64
- Frequent use of the zoom function consumes more power.
- The camcorder can record the sound of the zoom mechanism.

Basic playback

CHANGING THE PLAYBACK MODE

You can switch to the playback mode by selecting "Album" on the Home menu. You can also switch the operation mode directly into the playback thumbnail display by touching the Playback () tab on the LCD screen.

- The most recently created file is highlighted in the thumbnail view.
- The camcorder selects the thumbnail display options based on the standby mode that was last used. However, you can choose the video or photo thumbnail view display options by touching the Video thumbnail view () or Photo thumbnail view () tab on the LCD screen.

Understanding how to change the operation modes

You can easily change the playback mode by touching the LCD screen or using the button as shown in the following figures:

Using the Playback () tab

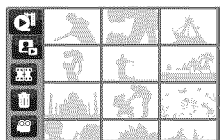
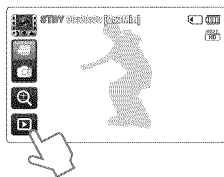

<Video thumbnail view>

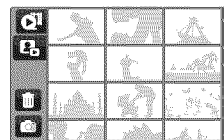

<Photo thumbnail view>

Using the Home () button

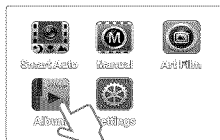
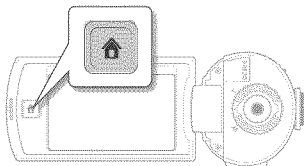

<Home menu>

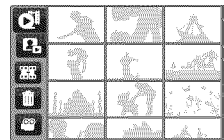

<Video thumbnail view>

- You can choose the thumbnail display type you want by selecting "Thumbnail" in the Settings menu or using the Zoom dial. ➔ page 65
- You can switch the playback mode to the recording mode by pressing the Recording start/stop button.

PLAYING VIDEOS

You can preview recorded videos in the thumbnail index view, find and play your desired video directly.

- Insert a memory card. ▶page 30
- Select the video playback mode. ▶page 41

- 1 Touch the thumbnail of the desired video clip.
 - The camcorder plays the video you selected.

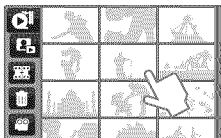

- 2 To stop playback and return to the thumbnails, touch the Thumbnail view (🖼️) tab.

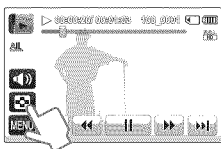

Find videos in various ways

Drag the thumbnails to up or down on the LCD screen to search the thumbnails you want.

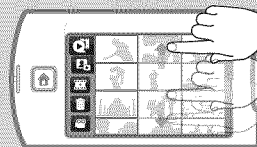

When playback is paused, drag the image to left or right on the LCD screen to go to the previous or next file.

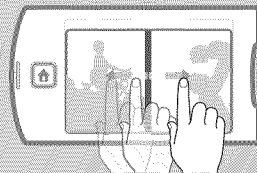

Touch a point or drag the pointer to left or right in the playback progress bar on the LCD screen to move directly to the section of the video you want.

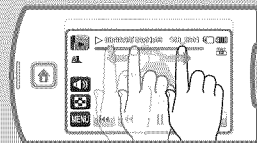

 Do not power off or eject the memory card during photo playback. Doing so may damage the recorded data.

-  • It may take some time to start playback, depending on the size and quality of the selected video.
- The camcorder may not play back the following video files:
 - A video recorded on another device.
 - A video whose file format is not supported by the camcorder.
- You can use various playback options during the video playback. [↪ page 44](#)
- You can set playback settings using the "Video Play Option" menu. [↪ page 66](#)
- You can play back the recorded videos on a TV or PC. [↪ pages 80~82, 86~92](#)
- If you touch the MENU (MENU) tab or press the Home (HOME) button during playback, the video playback is paused and the menu screen appears.

▶ To adjust the volume during video playback

You can hear the sound through the internal speaker of the camcorder while the video is playing back on the LCD screen.

- 1 Touch the Volume (VOLUME) tab on the LCD screen.

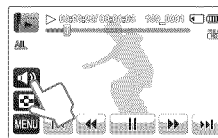

- 2 Touch the (-)/(+) tab to increase or decrease audio volume.

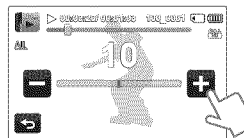

-  • The sound level is adjusted between "0~19". When the level is at "0", you cannot hear sound.
- When the camcorder is connected to a TV, you will not hear the sound from the speaker on the camcorder.

Various playback operations

Playback / Pause / Stop

- Playback and pause alternate when you touch the Playback (▶) / Pause (⏸) tab during playback.
- Touch the Thumbnail view (🖼️) tab to stop playback and return to the thumbnail.

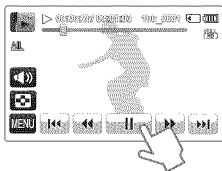

Search playback

During playback, each touch of the Reverse search (⏮️) / Forward search (⏭️) tab increases the playback speed:

- RPS (Reverse Playback Search)/FPS (Forward Playback Search) rate: $x2 \rightarrow x4 \rightarrow x8 \rightarrow x2$

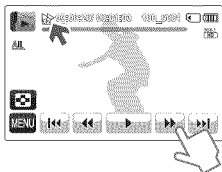

Skip playback

Touch the Reverse skip (⏮️) / Forward skip (⏭️) tab during playback.

- Touching the Forward skip (⏭️) tab plays the next video.
- Touching the Reverse skip (⏮️) plays the beginning of the scene. If reverse skip (⏮️) is touched within 3 seconds from the start of the file, the previous video plays.
- Place and hold your finger on the Reverse skip (⏮️) / Forward skip (⏭️) tab to search for a video quickly. When you lift off your finger, the selected video plays.

Slow playback

When playback is paused, touching the Reverse slow (⏪️) / Forward slow (⏩️) tab reduces the playback speed:

- Reverse/forward playback slow rate: $x1/2 \rightarrow x1/4 \rightarrow x1/8 \rightarrow x1/2$

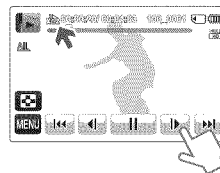

Frame by frame playback

When playback is paused, touching the Reverse frame advance (⏮️) / Forward frame advance (⏭️) tab makes playback go reverse or forward one frame at a time.

- Touch the Playback (▶) tab to play back in normal speed.
- You can hear sound only when the playback is in normal speed.

VIEWING PHOTOS

You can view recorded photos by using various playback functions.

- ☑ Insert a memory card. ▶page 30
- ☑ Select the photo playback mode. ▶page 41

- 1 Touch the thumbnail of the desired photo.
 - The camcorder displays the photo you selected in full screen.

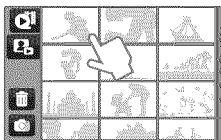

- 2 To return to the thumbnails, touch the Thumbnail view (🖼️) tab.

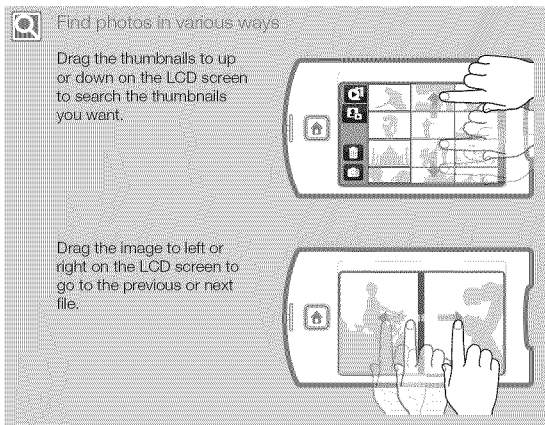

- ⚠ Do not power off or eject the memory card during photo playback. Doing so may damage the recorded data.

- ⚡ • Loading time may vary depending on the size and quality of the photo you selected.
- Your camcorder may not play back the following photo files normally:
 - A photo recorded on another device.
 - A photo with a file format not supported by this camcorder. (One that does not conform to DCF standards.)

Viewing a slide show

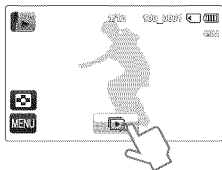

You can view a photo slide show with background music.

- 1 Touch the Slide Show () tab during photo playback.
 - The slide show starts from the current selected photo.
 - To pause the slide show, touch the LCD screen anywhere.

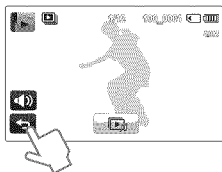

- 2 To stop the slide show, touch the Return () tab.





-  All photos are played back depending on the slide show options.
 - page 66
- You can adjust the background music's volume level using the Volume () tab while playing back the slide show with music.

Zooming during photo playback

You can magnify a playback image.

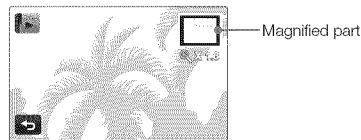
- 1 Touch the desired photo.
 - The selected photo appears on the full screen.
- 2 Adjust the magnification with the **Zoom dial**.
 - Magnification starts from the center of the photo.
 - You can zoom in from X1.1 to X8.0.
- 3 Drag the LCD screen to up/down/left/right to view the area you want on the magnified photo.



- 4 To cancel, touch the Return () tab.

-  Photos recorded on other devices or those edited on a PC cannot be magnified.
- While the playback zoom is in use, the other images cannot be selected.

Using the menu items

HANDLING MENUS

With Home menu, you can use various functions and change their settings according to your preference. The camcorder offers five categories as Home menu and each category has submenu items.

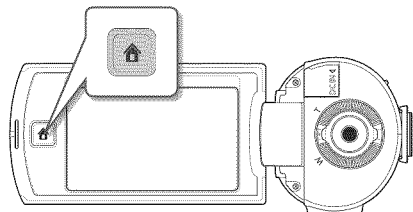

Using the Home (🏠) menu

- 1 Press the **Home** (🏠) button to display the Home menu screen.



- 2 Touch one of five categories you want on the Home menu.
 - The items of the selected category appears.
 - If you select **"Smart Auto"**, the Smart Auto mode is switched to.
 - If you select **"Album"**, the thumbnail view of the recorded image is switched to.

- 3 Select the desired item, and then adjust the setting values you want.

- The White Balance function of **"Manual"** is used here as an example.



| Categories | Functions |
|-------------------|--|
| Smart Auto | Switches to Smart Auto mode. ▶ page 39 |
| Manual | Items to adjust for scene conditions. ▶ pages 50~53 |
| Art Film | Item for a fun and unique look. ▶ pages 54~57 |
| Album | Items for playback and editing. ▶ pages 58~62 |
| Settings | Items for other settings (Shooting, Playback, Display, Connectivity, General). ▶ pages 63~79 |



- When using the Home menu items, some menu items can not be used at the same time, or may be grayed out. For more information, see Troubleshooting on page 103
- For easy understanding, the menu setting procedures on this page are explained using the simplest methods. Menu setting methods can differ depending on the menu options you choose.

MENU ITEMS

- The items available in each menu vary depending on the operating mode.
- For item operation details, see the page number listed under Page in the table.

Manual menu items

• : Accessible
X : Not accessible

| Items | Operation mode | Video | Photo | Default value | Page |
|---------------|----------------|-------|-------|---------------|------|
| | | | | | |
| White Balance | | • | • | Auto | 50 |
| EV | | • | • | 0 | 51 |
| Back Light | | • | • | Off | 51 |
| Self Timer | | X | • | Off | 52 |
| Super C.Nite | | • | X | Normal | 52 |
| Cont. Shot | | X | • | Off | 53 |
| Focus | | • | X | Auto | 53 |

Art Film menu items

• : Accessible
X : Not accessible

| Items | Operation mode | Video | Photo | Default value | Page |
|----------------|----------------|-------|-------|---------------|------|
| | | | | | |
| Fader | | • | X | Off | 54 |
| Time Lapse REC | | • | X | Off | 55 |
| Digital Effect | | • | • | Off | 57 |

Album menu items

| Items | Operation mode | Video | | Photo | | Default value | Page |
|-----------|----------------|----------------|-------------|----------------|-------------|---------------|------|
| | | Thumbnail view | Single view | Thumbnail view | Single view | | |
| Delete | | • | • | • | • | - | 58 |
| Protect | | X | • | X | • | OFF | 59 |
| Divide | | X | • | X | X | - | 60 |
| Combine | | • | X | X | X | - | 61 |
| File Info | | X | • | X | • | - | 62 |

Settings menu items

| | Items | Default value | Page |
|---------------------|-------------------|------------------|------|
| Shooting | Video Resolution | Full HD 1080/60i | 63 |
| | Photo Resolution | 4.9M 2944X1656 | 63 |
| | OIS Duo | OFF | 64 |
| | Tele Macro | OFF | 64 |
| | Digital Zoom | ON | 65 |
| Playback | Thumbnail | 3X3 | 65 |
| | Video Play Option | Play All | 66 |
| | Slide Show Option | - | 66 |
| Display | LCD Brightness | - | 67 |
| | Guideline | Off | 67 |
| | Date/Time Display | Off | 68 |
| | TV Display | ON | 68 |
| | HDMI TV Out | Auto | 69 |
| | Auto LCD Off | ON | 69 |
| Connectivity | PC Software | ON | 70 |
| | USB Connect | Mass Storage | 70 |
| | TV Connect Guide | - | 71 |
| | Anynet+(HDMI-CEC) | ON | 71 |

| | Items | Default value | Page |
|----------------|----------------|------------------------|------|
| General | Card Info | - | 72 |
| | File No. | Series | 72 |
| | Time Zone | Home | 73 |
| | Date/Time Set | JAN/01/2011 12:00AM | 73 |
| | Date Type | JAN/01/2011 | 73 |
| | Time Type | 12 Hr | 74 |
| | Beep Sound | ON | 74 |
| | Shutter Sound | ON | 75 |
| | Auto Power Off | 5 Min | 75 |
| | Quick On STBY | Off | 76 |
| | Switch Grip | ON | 77 |
| | Format | - | 77 |
| | Default Set | - | 78 |
| | Language | English | 78 |
| | Demo | ON | 79 |



Menu options and default values may be changed without prior notice.

Advanced recordings

White Balance

The color of your image depends on the type and quality of the light source. If you want the color of your image to be realistic, select an appropriate lighting condition to calibrate the white balance.

- 1 Press the **Home** (🏠) button → touch **"Manual"** → touch the White Balance (📷) tab.
- 2 Touch the desired submenu item.

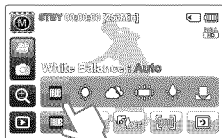

Submenu items

- **Auto** (📷): Adjusts the white balance automatically according to the recording conditions.
- **Daylight** (☀️): Use outdoors in normal daylight. Adjusts the white balance according to outdoor lighting conditions.
- **Cloudy** (☁️): Use when recording in the shade or cloudy weather.
- **Fluorescent** (💡): Use when recording under white fluorescent lights.
- **Tungsten** (💡): Use when recording under halogen lamps and incandescent lights.
- **Custom WB** (📷): Lets you manually adjust the white balance to match the light source or situation.



Understanding White Balance

White balance (WB) is the process of removing unrealistic color casts, so that objects which appear white are rendered white in your image. Proper white balance has to take into account the "color temperature" of a light source, which refers to the relative warmth or coolness of white light.

To set the white balance manually

- 1 Press the **Home** (🏠) button → touch **"Manual"** → touch the White Balance (📷) tab → touch the Custom WB (📷) tab.
 - The "(📷) **Set White Balance**" indicator appears.
- 2 Fill the screen with a white object, and then touch the (OK) tab.
 - The white balance setting is stored.
 - The stored white balance setting will be applied the next time you record.

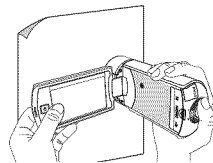

- When setting the white balance manually, the subject must be white, otherwise, your camcorder may not detect an appropriate setting value.
- The adjusted setting remains until you set the white balance again.
- During normal outdoor recording, setting to **"Auto"** may provide better results.
- Cancel the digital zoom function for clear and precise setting.
→ page 65
- Reset the white balance if light conditions change.

EV (Exposure Value)

Depending on the intensity of the ambient light, your videos and photos may be too bright or dark. In these cases, you can adjust the exposure to get a better videos and photos.

- 1 Press the **Home** (🏠) button → touch “Manual” → touch the EV (EV) tab.
- 2 Touch the decrease (−) or increase (+) tab to adjust the setting values.
 - The setting values range from -2.0 to +2.0

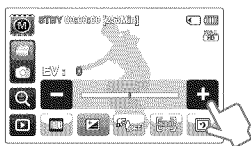

Understanding EV (Exposure Value)

Exposure value is the total amount of light allowed to fall on the photographic medium (Image sensor) during the process of taking photos or videos. The higher the number, the greater the exposure. For example, + 0.3 lets in more light than -0.3.



Back Light

When a subject is lit from behind, this function compensates for back lighting so that the subject does not appear too dark.

- 1 Press the **Home** (🏠) button → touch “Manual” → touch the Back Light (Back Light) tab.
- 2 Touch the desired submenu item.



Submenu items

- **Off** (Off): Disables the function.
- **On** (On): Backlight compensation brightens the subject.

Back lighting causes the subject to be darker than the background

It typically occurs when:

- The subject is in front of a window.
- The person you want to record is wearing white or shiny clothes and is placed against a bright background. The person's face is too dark to distinguish his/her features.
- The subject is outdoors and the background is overcast.
- The light sources are too bright.
- The subject is in front of a snowy background.



Self Timer

When the self-timer is enabled, there is a time delay of 10 seconds before recording starts. You can take photos of yourself.

 Select the photo recording mode. [▶page 26](#)

- 1 Press the **Home** (🏠) button → touch **"Manual"** → touch the Self Timer (🕒) tab.
- 2 Touch the desired submenu item.

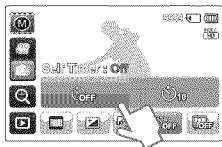

Submenu items

- **Off** (🕒): Disables the function.
- **On** (🕒): There is a time delay of 10 seconds after you press the **Recording Start/Stop** button.

-  The camcorder automatically turns the Self Timer function off after it has been used once. You must turn it on each time you want to use it.
- When the camcorder exits from Manual mode, the Self Timer function is automatically set to Off.

Super C.Nite

Use to get better images of slowly moving subjects or subjects in dark places. When you turn the Super C.Nite function on, the camcorder adjusts the shutter speed so that the images are brighter without compromising color.

 Select the video recording mode. [▶page 26](#)

- 1 Press the **Home** (🏠) button → touch **"Manual"** → touch the Super C.Nite (🌙) tab.
- 2 Touch the desired submenu item.

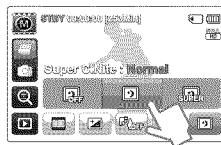

Submenu items

- **Off** (🌙): Disables the function.
- **Normal** (🌙): The shutter opens for 1/60 of a second in the normal mode and automatically switches to open for 1/30 of a second in a dark place. Use this function to get bright images in a dark place.
- **Super** (🌙): The shutter opens for 1/15 of a second regardless of surrounding conditions. Use this function to get bright images in a darker place.

-  The images may not seem smoothly because the camcorder has recorded them with the low shutter speed when using Super C.Nite.

Cont. Shot

The Continuous Shot function lets you capture up to eight photos in rapid.

 Select the photo recording mode. [page 26](#)

- 1 Press the **Home** (🏠) button → touch **"Manual"** → touch the Cont. Shot (📷) tab.
- 2 Touch the desired submenu item.



Submenu items

- **Off** (📷): The camcorder records only one photo image.
- **On** (📷): When you press the **Recording start/stop** button, the camcorder can take up to 8 photos in one second.

- 
- When an error occurs (Card Full, etc.) during continuous shot, the recording stops and an error message appears.
 - When the Cont. Shot is On, the photo resolution is fixed to 1920x1080.
 - When the camcorder exits from Manual mode, the Cont. Shot function is automatically set to Off.

Focus

The camcorder usually focuses on a subject automatically (auto focus). When you turn the camcorder on, focus is always set to automatic. You can also set the focus manually.

 Select the video recording mode. [page 26](#)

- 1 Press the **Home** (🏠) button → touch **"Manual"** → touch the Focus (🔍) tab.
- 2 Touch the desired submenu item.



Submenu items

- **Auto** (🔍): In most situations, it is better to use the automatic focus feature, as it lets you concentrate on the creative side of your recording.
- **Manual** (🔍): You may need to focus manually under conditions in which automatic focusing is difficult or unreliable. To adjust the focus, place and hold your finger on the (🔍) for a nearer subject, and on the (🔍) for a farther subject. The nearer or farther icon (🔍/🔍) appears when focus adjustment reaches the end. The camcorder applies the adjusted value right after you touch the (🔍) or (🔍) tab.

- 
- The Auto Focus (AF) setting is useful when you operate the zoom function because you might not be able to keep accurate focus after the zoom ratio has been changed.
 - In the manual focus setting menu screen, you can access auto focus by touching the AF (🔍) tab on the screen. You can return to manual focus by touching the manual focusing tabs.
 - When the camcorder exits from Manual mode or switch to the photo recording mode, the Focus function is automatically set to Auto.

Special effects for recordings

Fader

You can give your recording a professional look by using special effects such as fade in at the beginning of a sequence or fade out at the end of a sequence.

 Select the video recording mode. → page 26

- 1 Press the **Home** (🏠) button → touch **"Art Film"** → touch the **Fader** (🔍) tab.
- 2 Touch the desired submenu item.

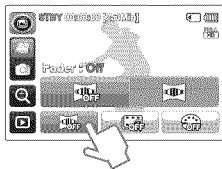

Submenu items

- **Off** (🔍): Disables the function.
- **On** (🔍): When you start or stop recording, the recording fades in or fades out accordingly.

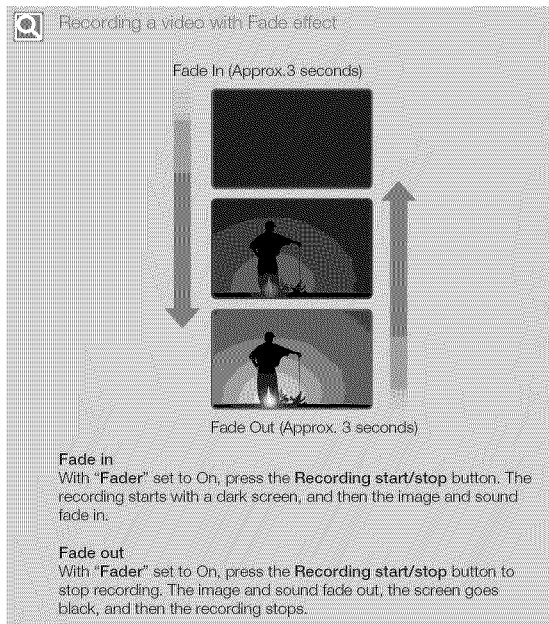

-  The camcorder automatically turns the Fader function off after it has been used once. You must reset it each time you want to use it.
- When the camcorder sets the Time Lapse REC function to On or exits from the Art Film mode, the Fader function is automatically set to Off.

Time Lapse REC

Using the Time Lapse feature, you can program your camcorder to create a time lapse video by recording a series of frames over a set period of time with a set time interval between each frame. The Time Lapse feature lets you create time lapse videos of blooming flowers and similar subjects.

- ✔ Select the video recording mode. ▶ page 26
- ✔ To record in the Time Lapse REC mode, you must set the recording interval between frames (Interval) using the menu.

- 1 Press the **Home** (🏠) button → touch **"Art Film"** → touch the Time Lapse REC (📷) tab.

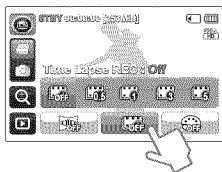

- 2 Touch the desired submenu item.

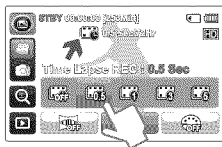

- 3 After setting the Time Lapse REC mode, press the **Recording start/stop** button.
 - The Time Lapse recording starts.
 - Time Lapse REC only supports the 720/60p resolution.



Submenu items

- **Off** (📷): Disables the function.
- **0.5 Sec** (📷): Enables the interval recording function. Images are automatically captured one frame at a time, at 0.5 seconds interval and stored in the storage media.
- **1 Sec** (📷): Enables the interval recording function. Images are automatically captured one frame at a time, at 1 second interval and stored in the storage media.
- **3 Sec** (📷): Enables the interval recording function. Images are automatically captured one frame at a time, at 3 seconds interval and stored in the storage media.
- **5 Sec** (📷): Enables the interval recording function. Images are automatically captured one frame at a time, at 5 seconds interval and stored in the storage media.

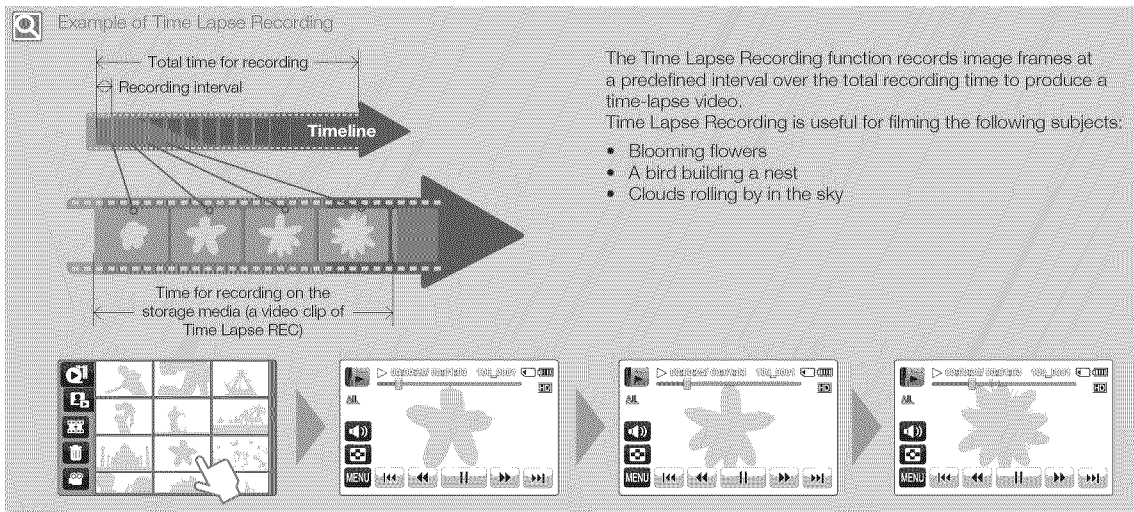

- Time lapse recording mode is released once recording has been finished. To start another Time Lapse Recording, repeat steps 1 to 3.
- When the camcorder sets the Fader function to On or exits from the Art Film mode, the Time Lapse REC function is automatically set to Off.
- 60 captured images compose a video of 1 second length. Since the minimum length of a video to be saved by your camcorder is one second, the interval defines how long the time lapse recording should be. For example, if you set the interval to "5 Sec", time lapse recording should be set to at least 10 minutes to record a minimum video length of 2 seconds (120 images).
- Time lapse REC function lets the camcorder record up to 72 hours until you stop recording or turn the camcorder's power off.
- Once time lapse recording finishes the camcorder switches to the standby mode.
- You cannot pause recording during Time lapse recording.
- Press the **Recording start/stop** button if you want to stop time lapse recording.
- Audio is not recorded during time lapse recording.
- If a video recording fills up 1.8GB of storage memory, a new recording file is automatically started at that point.
- If the battery charge is exhausted during the time lapse recording, the camcorder saves the recording up to that point and switches to standby mode. After some time, it displays a warning message, then turns off automatically.
- If memory runs out during a Time Lapse REC, the camcorder switches to standby mode after saving what was recorded so far.
- We recommend using the AC power adaptor for a time lapse recording.

Digital Effect

Using the Digital Effect function gives your recording a creative look.

- 1 Press the **Home** (🏠) button → touch "Art Film" → touch the Digital Effect (🎨) tab.
- 2 Touch the desired submenu item.
 - You can view the hidden items by dragging the LCD screen to left or right.

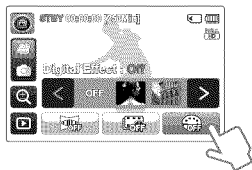

Submenu items



Off (🎨)
Without any Digital Effect, a normal, natural image is displayed during recording or playback.



Black & White (🎨)
This mode changes the image to black and white.



Sepia (🎨)
This mode gives the image a reddish brown look.



Negative (🎨)
This mode reverses the colors, creating a negative image.



Art (🎨)
This mode helps adjust for facial imperfections.



Noir (🎨)
This mode creates a stronger image by increasing contrast.



Western (🎨)
This mode creates a faded and old film vintage look.



Dazzle (🎨)
This mode creates a brighter image by increasing color saturation.



Ghost (🎨)
This mode creates a drawn out image effect like an apparition or ghost. (Video recording mode only)

Editing videos and photos

Delete





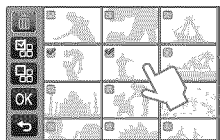

You can erase your recordings one by one or all at once.

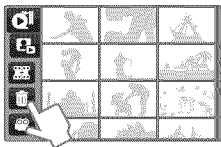
- Insert a memory card. [↖page 30](#)
- Select the video playback mode or photo playback mode. [↖page 41](#)



- 1 Touch the Delete () tab on the thumbnail view display.



- 2 Touch the files you want to delete. After you have selected all the files you want to delete, touch the () tab.
 - The delete () indicator appears on the selected files. Whenever you touch the thumbnail file, the selection () and release alternate.
 - To delete all the files, touch the Select all () tab. The delete () indicator appears on all the thumbnails.
 - To release the delete () indicator all at once, touch the Clear () tab.



- 3 Touch "Yes".
 - The camcorder deletes all the files having the delete () indicator.

- Deleted images cannot be recovered.
- Do not eject a memory card or power off while deleting videos recorded on the storage media. Doing so may damage the storage media or data.

- You can also operate this function in the full and single image display mode.
- To protect important images from accidental erasure, activate the image protection function in advance. [↖page 59](#)
- You cannot delete protected files. Cancel the protect function first. [↖page 59](#)
- If the write protection tab on the memory card is set to lock, you cannot delete the images. [↖page 31](#)
- The delete function does not work if battery charge is insufficient. It is recommended to use AC power to continue power supply during the deletion.

Protect

You can protect important recordings from accidental erasure. The protected videos and photos can not be deleted unless you format the memory card or cancel the protection.

-  • Insert a memory card. [▶page 30](#)
-  • Select the video playback mode or photo playback mode. [▶page 41](#)

- 1 Touch the file you want to protect.

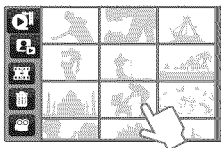

- 2 Touch the MENU (MENU) tab → Touch the desired item next to "Protect".

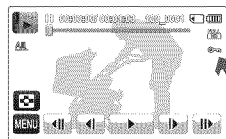
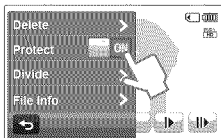

Submenu items

- **OFF:** Turns off protection on protected image.
- **ON(🔒):** Protects the selected image.

-  • You can operate this function in the full and single image display mode only.
- If the write protection tab on the memory card is set to lock, you cannot apply this function. [▶page 31](#)

Divide

You can divide a video into two, and easily delete a section you no longer need. As this function edits the original file, make sure to back up the original before dividing it.

- ✔ Insert a memory card. ➔page 30
- ✔ Select the video playback mode. ➔page 41

- 1 Touch the video you want to edit.
- 2 Touch the MENU (MENU) tab → touch **"Divide"**.
 - The selected video appears as paused.

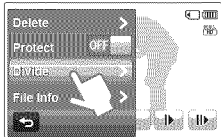

- 3 Find the point of division by touching the playback control tabs.
 - Playback control tabs: [Previous] [Play/Pause] [Next] [Stop] [Fast Forward] [Fast Reverse]
 - Drag the playback progress bar to left or right on the LCD screen to move directly to the division point.
- 4 Touch the Pause (PAUSE) tab at the point of division, and then touch the Cutting (CUTTING) tab.
 - A message appears asking for your confirmation.

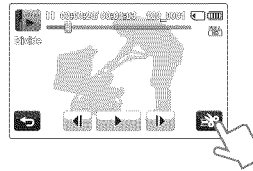



- 5 Touch **"Yes"**.
 - The video is divided into two video clips.
 - The second portion of the divided video is displayed as the last thumbnail.
 - After the division, you can partially delete unnecessary sections of the divided videos or combine them with other videos.

 Do not eject a memory card or power off while editing a video recorded on the storage media. Doing so may damage the storage media or data.

-  • You can operate this function in the single image display mode only.
- You cannot divide files that display the protect indicator (Ⓜ). Cancel the protect function first. ➔page 59
- The beginning or end of the divided videos may drift by approx. 2 seconds before or after the division point.
- The Divide function is not available under the following conditions:
 - If the total recorded time of the video is less than 6 seconds.
 - If you trying to divide sections without leaving 3 seconds at the beginning and the end.
 - If the remaining section of the memory space is less than 15MB.
 - When the number of files reaches 9999.
- Photos cannot be divided.



Combine

You can combine two different videos. As this function edits the original files, make sure to back up the original files before combining them.

-  • Insert a memory card. ➔page 30
-  • Select the video playback mode. ➔page 41

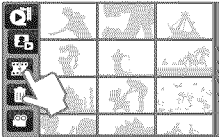
- 1 Touch the Combine () tab on the thumbnail view display.



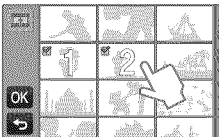

- 2 Touch the video thumbnails of the videos you want to combine in the order you want them combined.
 - The Combine () indicator and the order number appear on the selected videos. Whenever you touch the video thumbnail, the selection () and release alternate.
 - The checkbox on the video thumbnail does not appear if the video files have different resolutions.



- 3 Touch the () tab.
 - A message appears asking for your confirmation.
- 4 Touch "Yes".
 - The camcorder combines the video files you selected in the order you designated, and then stores the combined videos as a single video file.

 Do not eject a memory card or power off while editing a video recorded on the storage media. Doing so may damage the storage media or data.

-  • You cannot combine the files that are protected (). Cancel the protect function first. ➔page 59
- The original videos are not preserved.
- The Combine function is not available under the following conditions:
 - If the Videos are in different resolution formats. For example, videos recorded at "Video Resolution: Full HD 1080/60i" and "Video Resolution: HD 720/60p" cannot be combined.
 - If the file size of the combined videos exceeds 1.8 GB.
 - If the remaining memory space on your memory card is less than 15MB.
 - If a video file format is not supported by the camcorder.
 - When the camcorder is playing a video file.

File Info

You can see image information for each image.

- Insert a memory card. ↪page 30
- Select the video playback mode. ↪page 41

1 Touch the desired file to view the file information.

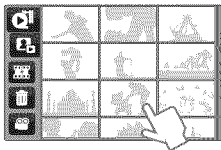

2 Touch the MENU (MENU) tab → touch “File Info”.
 • The information of the selected file appears.



3 To exit the menu, touch the Return (RETURN) tab.

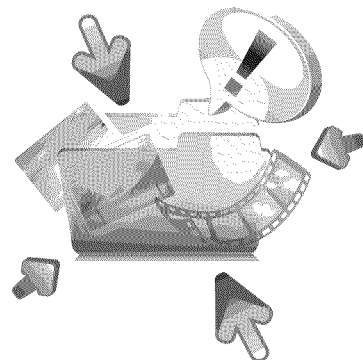

Other settings

Video Resolution

You can select the resolution of video to be recorded on storage media.

- 1 Press the **Home** (🏠) button → touch “**Settings**” → “**Shooting**” → “**Video Resolution**”.
- 2 Touch the desired submenu item.

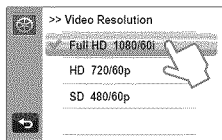

- 3 To exit the menu, touch the Return (↩) tab.

Submenu items

- **Full HD 1080/60i** (📺): Records in the Full HD (1920x1080/60i) format.
- **HD 720/60p** (📺): Records in the HD (1280x720/60p) format.
- **SD 480/60p** (📺): Records in the SD (720x480/60p) format.

- 📖 • “60i” indicates the camcorder will record in interlaced scan mode at 60 fields per second.
- “60p” indicates the camcorder will record in progressive scan mode at 60 frames per second.
- Recorded files are encoded using Variable Bit Rate (VBR). VBR is an encoding system that automatically adjusts the bit rate in response to the image being recorded.
- The available video recording time differs according to the video resolution you select. ➡ page 33

Photo Resolution

You can select the resolution of the photo to be recorded.

- 1 Press the **Home** (🏠) button → touch “**Settings**” → “**Shooting**” → “**Photo Resolution**”.
- 2 Touch the desired submenu item.

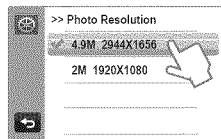

- 3 To exit the menu, touch the Return (↩) tab.

Submenu items

- **4.9M 2944X1656** (📺): Records in the 2944x1656 resolution.
- **2M 1920X1080** (📺): Records in the 1920x1080 resolution.

- 📖 • The number of recordable images differs according to the photo resolution you select. ➡ page 33
- Photos that are recorded on your camcorder may not playback properly on other digital devices that do not support these photo sizes.

OIS Duo

Reduce camcorder shake and prevent blurred images with Optical and Digital Image Stabilization functions.

- 1 Press the **Home** (🏠) button → touch “Settings” → “Shooting”.
- 2 Touch the desired item next to “OIS Duo”.

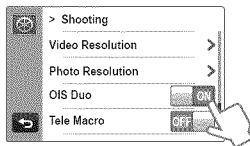

- 3 To exit the menu, touch the Return (↩) tab.

Submenu items

- **OFF**: Disables the function.
- **ON** (🏠): The OIS Duo function is enabled to compensate for shaking.

Tele Macro

Using the Tele Macro function, you can get close up images which are created by focusing on a small portion of a large object at a tele angle. It is useful to get close up images of flowers or insects etc.

- 1 Press the **Home** (🏠) button → touch “Settings” → “Shooting”.
- 2 Touch the desired item next to “Tele Macro”.

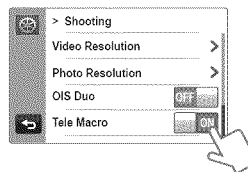

- 3 To exit the menu, touch the Return (↩) tab.

Submenu items

- **OFF**: Disables the function.
- **ON** (🏠): You can focus on a small portion of a large object at a tele angle.



- When recording in Tele Macro mode, the focus speed may be lowered.
- Use a tripod (not supplied) to prevent camcorder shake in the Tele Macro mode.
- Avoid shadows when recording in the Tele Macro mode.
- As the distance to the subject decreases, focusing area narrows.
- When the distance between the camcorder and a subject is too close and the camcorder cannot be in the focus, rotate the **Zoom dial** towards **W** (wide-angle) a little bit and then adjust the focal distance between them.
- When the Tele Macro is On and the camcorder magnifies a subject in tele mode, the minimum focal distance between the camcorder and a subject is 50cm.

Digital Zoom

The images optically magnified by the lens can be electronically magnified up to the maximum 200 times.

- 1 Press the **Home** (🏠) button → touch “Settings” → “Shooting”.
- 2 Touch the desired item next to “Digital Zoom”.

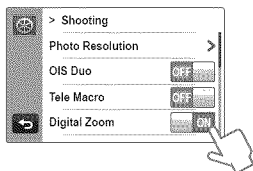

- 3 To exit the menu, touch the Return (↩) tab.

Submenu items

- **OFF**: Disables the digital zoom function. Only optical zoom is available.
- **ON**: Enables higher digital zoom magnification.

 When you use the digital zoom, the camcorder processes the image digitally more than in the optical zoom mode. As a result, the image resolution may deteriorate.

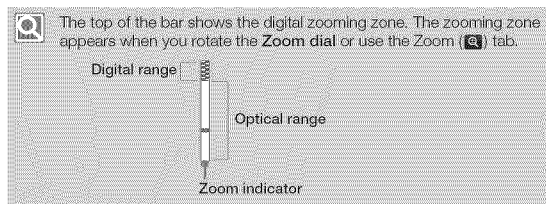

Thumbnail

You can choose the 3x3 or 4x4 type as the thumbnail view display.

- 1 Press the **Home** (🏠) button → touch “Settings” → “Playback” → “Thumbnail”.
- 2 Touch the desired submenu item.

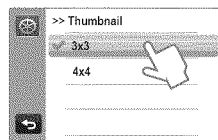

- 3 To exit the menu, touch the Return (↩) tab.

Submenu items

- **3X3**: Displays the 3x3 type as the thumbnail view display.
- **4X4**: Displays the 4x4 type as the thumbnail view display.

Video Play Option

You can set a specific playback style according to your preference.

- 1 Press the **Home** (🏠) button → touch “**Settings**” → “**Playback**” → “**Video Play Option**”.
- 2 Touch the desired submenu item.

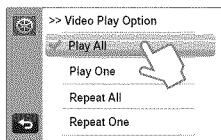

- 3 To exit the menu, touch the Return (↩) tab.

Submenu items

- **Play All** (🎬): Plays video clips in succession starting from the selected video to the last one, then returns to the thumbnail index view.
- **Play One** (🎬): Plays the selected video only, and returns to the thumbnail view.
- **Repeat All** (🔄): Plays all the video clips repeatedly until the Thumbnail view (🏠) tab is touched.
- **Repeat One** (🔄): Plays the selected video only repeatedly until the Thumbnail view (🏠) tab is touched.

Slide Show Option

You can set the playback options for the slide show with the slide show setting menus.

- 1 Press the **Home** (🏠) button → touch “**Settings**” → “**Playback**” → “**Slide Show Option**”.
- 2 Set the slide show options by touching the corresponding item or dragging it to up or down.

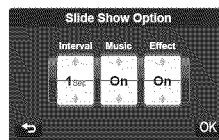

- 3 To exit the menu, touch the Return (↩) tab.

Submenu items

- **Interval**: Continuously plays back photos at the interval you select. You can choose 1 sec. or 3 sec.
- **Music**: You can turn the internal background music on or off. This camcorder has 7 default background melodies stored in the boot-up flash memory. If the music is on when the slide show starts, the 7 melodies will play back in shuffle mode.
- **Effect**: Continuously plays back photos using the fade in/out effect to transition between images.

LCD Brightness

This camcorder's LCD brightness is optimized at the factory. However, you can adjust the LCD brightness according to the ambient environment.

- 1 Press the **Home** (🏠) button → touch **"Settings"** → **"Display"** → **"LCD Brightness"**.
- 2 Touch the decrease (⊖) or increase (⊕) tab to adjust the setting values as you want.
 - You can set values for LCD brightness between 0 and 10.

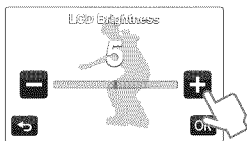

- 3 Touch the (OK) tab to complete the setting.
- 4 To exit the menu, touch the Return (↩) tab.

- ☑ • If the surroundings are too bright, adjust the brightness of the LCD screen.
- Adjusting the LCD screen does not affect the image you are recording.
- A brighter LCD screen consumes more power.

Guideline

Guideline displays straight line patterns on the LCD screen that can help you set the image composition when recording images. The camcorder provides 3 types of guidelines.

- 1 Press the **Home** (🏠) button → touch **"Settings"** → **"Display"** → **"Guideline"**.
- 2 Touch the desired submenu item.

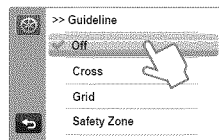

- 3 To exit the menu, touch the Return (↩) tab.

Submenu items

- **Off**: Disables the function.
 - **Cross** (⊕): Placing the subject at the center cross point puts the subject in the middle of the frame.
 - **Grid** (⊞): For recording multiple subjects. Putting subjects at or near the grid cross points creates a balanced composition.
 - **Safety Zone** (⊕): Positioning subjects within the Safety Zone rectangle ensures they will be recorded.
-
- ☑ • Positioning a subject at the cross point of a guideline provides a balanced composition.
 - Guidelines are not recorded.

Date/Time Display

You can set the Date/Time Display function so that the date and time appear on the LCD screen.

- 1 Press the **Home** (🏠) button → touch **"Settings"** → **"Display"** → **"Date/Time Display"**.
- 2 Touch the desired submenu item.

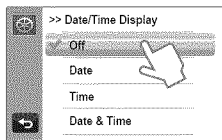

- 3 To exit the menu, touch the Return (↩) tab.

Submenu items

- **Off:** The current date/time information is not displayed.
- **Date:** Displays the current date.
- **Time:** Displays the current time.
- **Date & Time:** Displays the current date and time.



- The date/time will read "JAN/01/2011 12:00 AM" in the following case:
 - When the internal rechargeable battery is depleted.
- The date and time displayed by this function depend on the **"Date Type"** and **"Time Type"** settings. ↪pages 73-74

TV Display

When your camcorder is connected to a TV, you can select whether the camcorder's On Screen Display (OSD) appears on the TV screen.

- 1 Press the **Home** (🏠) button → touch **"Settings"** → **"Display"**.
- 2 Touch the desired item next to **"TV Display"**.

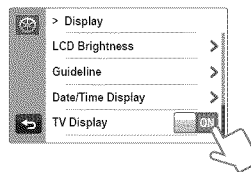

- 3 To exit the menu, touch the Return (↩) tab.

Submenu items

- **OFF:** The OSD (On Screen Display) menus are only shown on the LCD screen.
- **ON:** The OSD menus are shown on the LCD screen and the TV screen as well.



- The menu screen, thumbnail display, and demo screens are shown on the TV even if you set **"TV Display"** to **"OFF"**.

HDMI TV Out

You can set the HDMI video output to match the TV you have connected the camcorder to.

- 1 Press the **Home** (🏠) button → touch “**Settings**” → “**Display**” → “**HDMI TV Out**”.
- 2 Touch the desired submenu item.

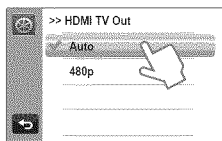

- 3 To exit the menu, touch the **Return** (↩) tab.

Submenu items

- **Auto:** The video signals are output in the same format as the recorded file. Use this setting only when connecting to an HDTV.
- **480p:** The recorded file is output in the 720x480p format. Use this setting only when connecting to a standard and analog TV which supports SD (Standard Definition) progressive scan (480p) signals through its HDMI jacks.

Auto LCD Off

You can set the LCD screen to darken automatically when there is no user interaction for a period of time to decrease power consumption.

- 1 Press the **Home** (🏠) button → touch “**Settings**” → “**Display**”.
- 2 Touch the desired item next to “**Auto LCD Off**”.

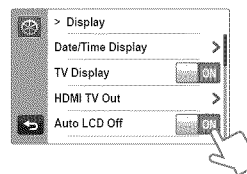

- 3 To exit the menu, touch the **Return** (↩) tab.

Submenu items

- **OFF:** Disables the function.
- **ON:** When the camcorder is idle for more than 2 minutes in the STBY mode, or for more than 5 minutes when recording a video, the power saving mode starts by dimming the LCD screen.



- When the “**Auto LCD Off**” function is enabled, you can press any button on the camcorder to return LCD brightness to normal.
- Auto LCD Off is disabled in the following cases:
 - When the camcorder has a cable connection. (USB cable, AC power adaptor, etc.)
 - While the Demo function is in operation.

PC Software

If you set PC Software to On, you can use the built-in video and photo management software by connecting your camcorder to your PC using the camcorder's USB cable. With this software, you can download stored video and photo images from the camcorder to your PC's hard disk and edit the video and photo files right on your PC's screen.

- 1 Press the **Home** (🏠) button → touch **"Settings"** → **"Connectivity"**.
- 2 Touch the desired item next to **"PC Software"**.

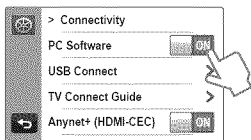

- 3 To exit the menu, touch the Return (↵) tab.

Submenu items

- **OFF**: Disables the function.
- **ON**: The built-in editing software launches when you connect the camcorder to a PC.

- The PC Software function is not available in the following conditions:
 - If **"USB Connect"** is set to **"PictBridge"**
 - To enable the PC Software function, set **"USB Connect"** to **"Mass Storage"**, in the system setting menu option. ↪ page 70
 - The PC Software is compatible with the Windows OS's only.

USB Connect

You can transfer data to a PC or print photos directly by establishing the USB connection.

- 1 Press the **Home** (🏠) button → touch **"Settings"** → **"Connectivity"** → **"USB Connect"**.
- 2 Touch the desired submenu item.

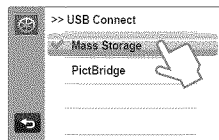

- 3 To exit the menu, touch the Return (↵) tab.

Submenu items

- **Mass Storage**: Connect to a PC to transfer videos or photos. ↪ page 91
- **PictBridge**: Connect to a PictBridge printer to print photos directly (when using the PictBridge function). ↪ page 84

- Before connecting a USB cable, check whether the current USB mode is appropriate for the function you want to use.

TV Connect Guide

You can view the TV Connect Guide for instructions before you connect the camcorder to your TV set.

- 1 Press the **Home** (🏠) button → touch **"Settings"** → **"Connectivity"** → **"TV Connect Guide"**.
- 2 Touch the desired submenu item.

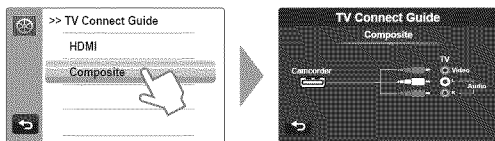

- 3 To exit the menu, touch the Return (⏪) tab.

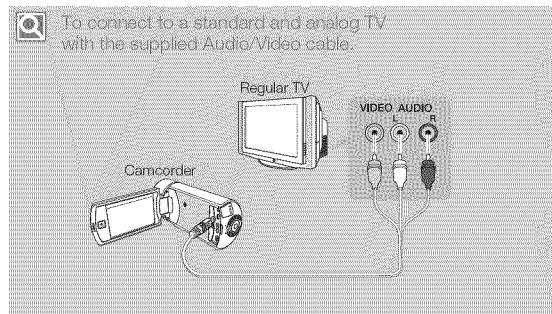

Anynet+ (HDMI-CEC)

This camcorder supports Anynet+. Anynet+ is an AV network system that lets you control all connected Samsung AV devices with a Samsung TV remote control that supports Anynet+.

- 1 Press the **Home** (🏠) button → touch **"Settings"** → **"Connectivity"**.
- 2 Touch the desired item next to **"Anynet+ (HDMI-CEC)"**.

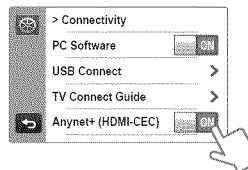

- 3 To exit the menu, touch the Return (⏪) tab.

Submenu items

- **OFF** : Disables the function.
 - **ON** : The Anynet+ function is enabled.
When the camcorder is connected to a TV that supports Anynet+, you can operate some functions of the camcorder using the TV's remote control.
-  • When you turn on the camcorder and it is connected by an HDMI cable to a TV that supports Anynet+, the TV automatically turns on. If you do not want to use the Anynet+ function, set the **"Anynet+ (HDMI-CEC)"** to **"OFF"**.
- For details on the Anynet+ (HDMI-CEC) function, refer to the user manual of Samsung's Anynet+ supported TV.

Card Info

This function shows you the storage information of the selected storage media, such as used memory space and available memory space, etc.

 Insert a memory card in the camcorder before viewing the storage information.

1 Press the **Home** () button → touch **"Settings"** → **"General"** → **"Card Info"**.

- Used memory space, available memory space, and the recordable time appear. Available space and recordable time depend on the video resolution you've selected.

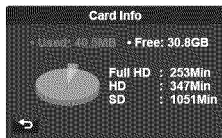

2 To exit the menu, touch the Return () tab.

-  • The actual capacity may be less than the capacity displayed on the LCD screen as the camcorder's system files occupy a part of the capacity.
- If there is no storage media inserted, you cannot select the Card Info and it will look dim on the menu.

File No.

File names (numbers) are assigned to recorded images according to the numbering option you select.

- 1 Press the **Home** () button → touch **"Settings"** → **"General"** → **"File No."**
- 2 Touch the desired submenu item.

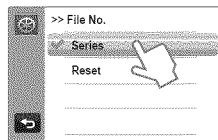

3 To exit the menu, touch the Return () tab.

Submenu items

- **Series:** Assigns file numbers in sequence even after you replace or format the storage media or delete all files. Each file is given a unique file number that allows convenient image management on a PC.
- **Reset:** Resets the file number to 0001 after you run format, delete all files or insert a new memory card.

 When you set **"File No."** to **"Series"**, each file is assigned a different number to avoid duplicating file names. This numbering scheme is very useful when you want to manage your files on a computer.

Time Zone

You can easily set the clock to the local time when using your camcorder while traveling.

Setting the local time

- 1 Press the **Home** (🏠) button → touch “Settings” → “General” → “Time Zone” → “Visit”.
- 2 Select the time zone by touching the left (◀)/right (▶) tab on the LCD screen, and then touch the (OK) tab.



- 3 To exit the menu, touch the Return (↩) tab.

Submenu items

- **Home:** The clock will be used according to your setting on the Date/Time Set menu. Select Home when using your camcorder for the first time or when returning the clock to your hometown date/time settings.
- **Visit (🌐):** When you visit a different time zone, the Visit function lets you use the local time without changing your hometown time setting. The clock is adjusted according to the time difference between your home and the location you are visiting.

Date/Time Set

By setting the date and time, you can display the date and time of the recording during playback. ➡ page 28

Date Type

You can set the date display to one of four types.

- 1 Press the **Home** (🏠) button → touch “Settings” → “General” → “Date Type”.
- 2 Touch the desired submenu item.

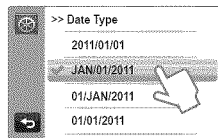

- 3 To exit the menu, touch the Return (↩) tab.

Submenu items

- **2011/01/01:** Displays the date in the year/month (two-digit)/day format.
- **JAN/01/2011:** Displays the date in the month/day/year format.
- **01/JAN/2011:** Displays the date in the day/month/year format.
- **01/01/2011:** Displays the date in the day/month (two-digit)/year format.



This function depends on the “Date/Time Display” setting. ➡ page 68

Time Type

You can set the time display type to 12 hour or 24 hour.

- 1 Press the **Home** (🏠) button → touch **"Settings"** → **"General"** → **"Time Type"**.
- 2 Touch the desired submenu item.

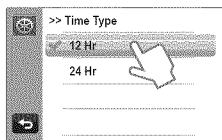

- 3 To exit the menu, touch the Return (↩) tab.

Submenu items

- **12 Hr:** Displays the time information in 12 hour units.
- **24 Hr:** Displays the time information in 24 hour units.

 This function depends on the **"Date/Time Display"** setting. ↪ page 68

Beep Sound

You can turn the beep that sounds when you touch tabs and buttons on the screen on or off.

- 1 Press the **Home** (🏠) button → touch **"Settings"** → **"General"**.
- 2 Touch the desired item next to **"Beep Sound"**.

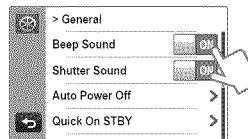

- 3 To exit the menu, touch the Return (↩) tab.

Submenu items

- **OFF:** Disables the function.
- **ON:** You will hear a beep sound when operating button or tabs such as **Recording start/stop** button.

 The Beep Sound is canceled in the following cases:

- During recording and playing
- When the camcorder has a cable connection. (Audio/Video cable, mini HDMI cable, etc.)

Shutter Sound

You can turn the shutter sound that plays when taking a photo with the **Recording start/stop** button on or off.

- 1 Press the **Home** (🏠) button → touch **"Settings"** → **"General"**.
- 2 Touch the desired item next to **"Shutter Sound"**.

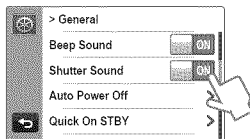

- 3 To exit the menu, touch the Return (↩) tab.

Submenu items

- **OFF:** Disables the function.
- **ON:** You will hear the shutter sound when taking a photo with the **Recording start/stop** button.



The camcorder does not make the shutter sound:
 - When the camcorder has a cable connection. (Audio/Video cable, mini HDMI cable, etc.)

Auto Power Off

You can set your camcorder to turn off automatically if it is idle for 5 minutes without performing an operation. This function prevents unnecessary power consumption.

- 1 Press the **Home** (🏠) button → touch **"Settings"** → **"General"** → **"Auto Power Off"**.
- 2 Touch the desired submenu item.

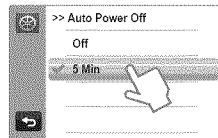

- 3 To exit the menu, touch the Return (↩) tab.

Submenu items

- **Off:** Disables the function.
- **5 Min:** The camcorder turns off if idle for 5 minutes without performing an operation.



- **Auto Power Off** does not work in the following situations:
 - When the camcorder has a cable connection. (USB cable, AC power adaptor, etc.)
 - While the Demo function is in operation.
 - While you are recording (including the recording pause), playing (except pause), or running a photo slide show.
- To turn the camcorder on again, close the LCD screen and then open it.

Quick On STBY

When you are going to record frequently for an extended time, use the Quick On STBY function to reduce energy consumption and battery drain. With the Quick On STBY function On, closing the LCD screen starts Quick On STBY.

- 1 Press the **Home** (🏠) button → touch **"Settings"** → **"General"** → **"Quick On STBY"**.
- 2 Touch the desired submenu item.

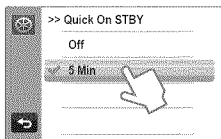

- 3 To exit the menu, touch the Return (↩) tab.

Submenu items

- **Off:** Closing the LCD screen turns off the camcorder.
- **5 Min:** Closing the LCD screen starts the Quick On STBY mode after a short period of time. After 5 minutes in Quick On STBY mode, the camcorder turns off.



- We recommend turning off the camcorder after use to reduce energy consumption. However, as an alternative, you can use the Quick On STBY function under most shooting conditions to reduce energy consumption effectively.
- The charging indicator keeps blinking in Quick On STBY mode.
- The Quick On STBY mode is not available under the following conditions:
 - When the LCD screen is open.
 - When you operate the buttons on the camcorder.
 - While recording.

Switch Grip

The camcorder is designed for you to use conveniently with either your right or left hand. If the **"Switch Grip"** sets to **"On"**, you can use the camcorder easily with both your hands.

- 1 Press the **Home** (🏠) button → touch **"Settings"** → **"General"**.
- 2 Touch the desired item next to **"Switch Grip"**.

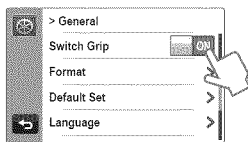

- 3 To exit the menu, touch the Return (↩) tab.

Submenu items

- **OFF** : Disables the function.
- **ON** : You can use the camcorder easily with both your hands.

Format

Use this function if you want to delete all files completely or to correct problems on the storage media.

- 1 Press the **Home** (🏠) button → touch **"Settings"** → **"General"** → **"Format"**.

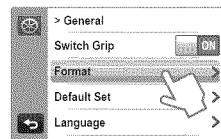

- 2 Touch **"Yes"** → **"Yes"**.
 - The format is executed with a message.
- 3 To exit the menu, touch the Return (↩) tab.



- Do not remove the storage media or perform any other operation (such as turning off the power) during formatting. Also, be sure to use the provided AC power adapter, as the storage media may be corrupted if the battery becomes exhausted during formatting.
- If the storage media becomes corrupted, format it again.



- Do not format the storage media on a PC or other device. Make sure to format the storage media on this camcorder.
- You cannot format a memory card with the protection tab set to lock. ➡ page 31
- If there is no storage media inserted, you cannot select the Format function, and its name will be dimmed on the menu.
- Formatting completely deletes all files and options on a memory card, including protected files. By deleting all files and options, formatting typically corrects problems, enabling stable read/write speeds and operation.

Default Set

You can restore all menu settings to the default conditions (factory settings).

- 1 Press the **Home** (🏠) button → touch **"Settings"** → **"General"** → **"Default Set"**.
 - A message appears asking for your confirmation.

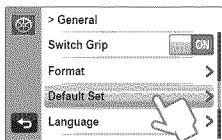

- 2 Touch **"Yes"** if you want all the settings returned to the default.
 - The Time Zone screen appears after all settings return to the default.
- 3 Set the date and time again. ➔ page 28



- Do not turn off the power while using this function.
- Initializing the camcorder settings to factory defaults does not affect recorded images.

Language

You can select the language the camcorder uses to display the menu and messages. ➔ page 29

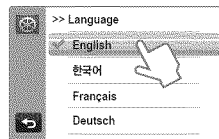

Supported languages

| | | | | |
|----------|------------|------------|----------|-----------|
| English | 한국어 | Français | Deutsch | Italiano |
| Español | Português | Nederlands | Svenska | Suomi |
| Norsk | Dansk | Polski | Čeština | Slovensky |
| Magyar | Română | Български | Ελληνικά | Srpski |
| Hrvatski | Українська | Русский | 中文 | 日本語 |
| עברית | Türkçe | ایرانی | العربية | עברית |

Demo

The Demo mode automatically shows you the major functions that are included with your camcorder so that you can use them more easily.

- 1 Press the **Home** (🏠) button → touch **"Settings"** → **"General"**.
- 2 Touch the desired item next to **"Demo"**.

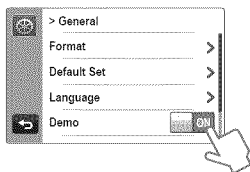

- 3 To exit the menu, touch the Return (↩) tab.

Submenu items

- **OFF**: Disables the function.
- **ON**: Enables the Demo function.



Using the Demo function

The Demo mode is canceled in the following cases:

- If the LCD screen is touched.
 - If you press any button (**Recording start/stop**, **Home** (🏠), etc.).
- However, the camcorder enters the Demo mode automatically after 5 minutes in STBY mode if it is idle for 5 minutes without an operation. If you don't want the Demo function to start, set **"Demo"** to **"OFF"**.



The Demo function does not operate in the following case:

- If you set **"Auto Power Off"** to **"5 Min"** and you are using the battery to power the camcorder, the Auto Power Off function turns the camcorder off before Demo runs.

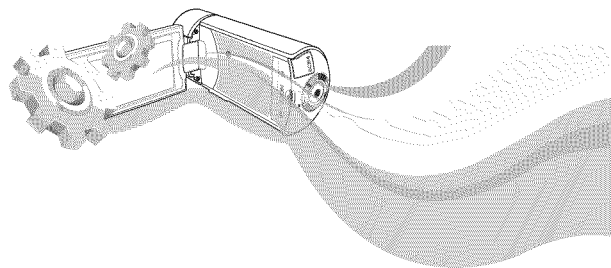

Connecting to a TV

CONNECTING TO A HIGH DEFINITION TV WITH HDMI

You can view High Definition (HD) quality videos recorded in HD resolution on an HDTV using an HDMI connection. This camcorder supports HDMI output to deliver high-definition video transfer.

- ✔ Check if there is an HDMI input jack on your TV.
- ✔ Use the AC power adaptor to power the camcorder when you attach it to a TV.
- ✔ Select "HDMI TV Out". ➡ page 69

Using a mini HDMI cable

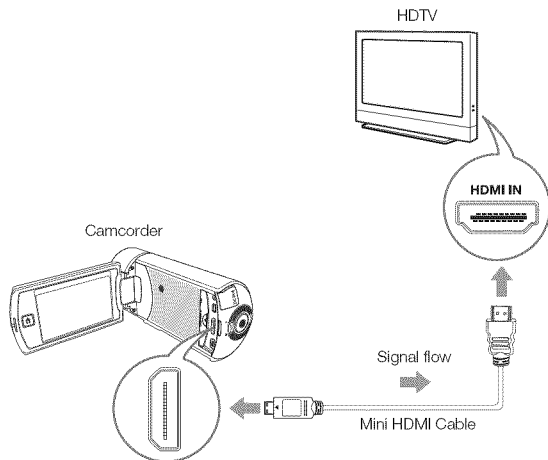

- 1 Turn on the camcorder.
 - If you do not turn on the camcorder first, the camcorder may fail to recognize the connected TV.
- 2 Connect the camcorder to the TV with a Mini HDMI cable.
- 3 Set the TV's input or source selector to the HDMI input you've attached the camcorder to.
 - Refer to the TV's instruction manual to see how to select the TV's input or source.
- 4 Select the playback mode on your camcorder, and then start to play back videos or photos. ➡ pages 42~46



Understanding the HDMI

HDMI (High Definition Multimedia Interface) is a compact audio/video interface for transmitting uncompressed digital data.

What is Anynet+ function?

The Anynet+ function lets you control all devices that support the Anynet+ function with the same remote. You can use the Anynet+ function on the camcorder if the camcorder is connected with an HDMI cable to an Anynet+ supported TV. For more information, refer to the Anynet+ supported TV's user manual.



- This camcorder is provided with the "TV Connect Guide" menu function. If you try to connect the camcorder to a TV and don't have your user's manual, you can use the "TV Connect Guide" menu function to view connection instructions on the camcorder's screen. ➡ page 71
- You can use only a C to A type Mini HDMI cable with this camcorder.
- The HDMI jack on the camcorder is for output only.
- If an Anynet+ supported TV is connected to the camcorder by an HDMI cable, turning on the camcorder may turn the TV's power on. (an Anynet+ function) If you don't want this to occur, set "Anynet+ (HDMI-CEC)" to "OFF". ➡ page 71
- Use only HDMI 1.3 cable when connecting to the HDMI jack of this camcorder. If the camcorder is connected with HDMI cables that are not version 1.3, the screen display may not work.

CONNECTING TO A REGULAR TV



You can view images recorded with your camcorder on a regular TV that supports standard definition. This camcorder supports the composite output for standard definition video transfer.

 Use the AC power adaptor to power the camcorder when you attach it to a TV.

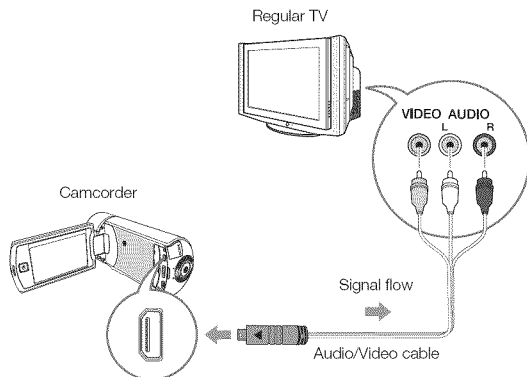
Connecting an Audio/Video cable for the composite output





- 1 Connect the camcorder to a TV with an Audio/Video cable.
- 2 Set the TV's input or source selector to the input you've attached the camcorder to.
 - Refer to the TV's instruction manual to see how to select the TV input.
- 3 Select the playback mode on your camcorder, and then start to play back videos or photos.  page 42-46

-  Make sure you've connected the camcorder to the correct input jacks. The TV screen may not display the right video information if connected incorrectly.
- When connecting to a TV using the Audio/Video cable, match the color of the cables to the color of the corresponding jacks.
- Video input may appear green depending on the TV. If this occurs, connect the yellow plug of the Audio/Video cable to the green jack of the TV.
- When the camcorder is connected to a TV with more than one kind of cable, the camcorder outputs video signals in the following order of priority:
 - HDMI → Audio/Video (composite) output
- This camcorder is provided with the "TV Connect Guide" menu function. If you try to connect the camcorder to a TV and don't have your user's manual, you can use the "TV Connect Guide" menu function to view connection instructions on the camcorder's screen.  page 71
- If your TV has one audio jack (mono input), connect the yellow plug of the Audio/Video cable to the video jack, the white plug to the audio jack, and leave the red plug unconnected.
- When you connect the camcorder to a TV using the Audio/Video cable, images recorded in high-definition image quality ("Full HD 1080/60i" or "HD 720/60p") are played back in standard definition image quality.

VIEWING ON A TV SCREEN

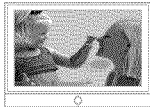
Image appearance depends on the TV screen aspect ratio

| Recording ratio | Appearance on Wide (16:9) TV | Appearance on 4:3 TV |
|---------------------------------|---|---|
| Images recorded in a 16:9 ratio |  |  |

- Adjust the volume to a moderate level. If the volume is too high, the video information may include noise.
- If "TV Display" is set "OFF", the TV screen does not display the camcorder's OSD (On Screen Display) menus. [▶ page 68](#)

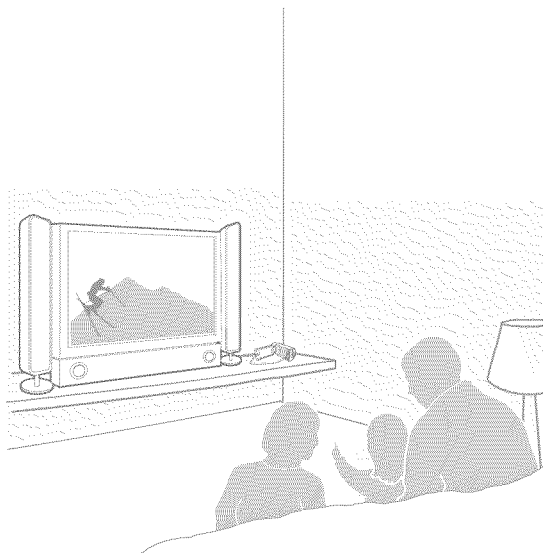

Dubbing videos

DUBBING TO A VCR OR DVD/HDD RECORDER

Videos recorded in this camcorder can be dubbed to a VCR or DVD/HDD recorders.

- Videos are dubbed to the other recording device via analog data transfer. (composite connection) Use the supplied Audio/Video cable.
- Use the AC power adaptor to power the camcorder when you dub to a VCR or DVD/HDD recorder.

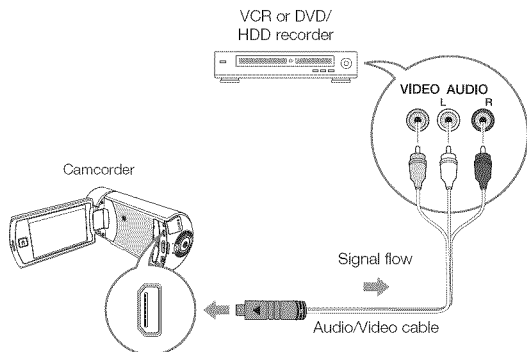

- 1 Connect your camcorder to the recording device (VCR or DVD/HDD recorder) with the Audio/Video cable.
 - Connect your camcorder to the input jacks of the recording device.
 - If your recording device has an input selector, set it to the correct input mode.
- 2 Insert the storage device (tape, disc, etc.) into the recording device.
- 3 Start the playback on your camcorder, and record it on the recording device.
 - Refer to the instruction manuals supplied with your recording device for details.
- 4 When dubbing is finished, stop the recording device, and the your camcorder.
 - Videos recorded on this camcorder can only be dubbed using the Audio/Video cable in SD (standard definition) image quality, regardless of the recording resolution (HD/SD).
 - You cannot dub to a recorder with an HDMI cable.
 - To copy a video recorded in HD (high definition) image quality in HD, use the built-in software of your camcorder, and copy the video to your computer. ➔ page 87
 - Because dubbing is performed via analog data transfer, the image quality may deteriorate.
 - To hide the screen indicators (such as the counter, etc.) on the screen of the connected monitor device set "TV Display: OFF". ➔ page 68
 - To record the date/time, display it on the screen. ➔ page 68

Printing photos

DIRECT PRINTING WITH A PICTBRIDGE PRINTER

You can print photos directly by connecting your camcorder to a PictBridge printer (sold separately) using a USB cable.

 Insert the memory card. [↪ page 30](#)

1 Set "USB Connect" to "PictBridge". [↪ page 70](#)

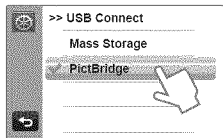

2 Use a USB cable to connect your camcorder to the printer.

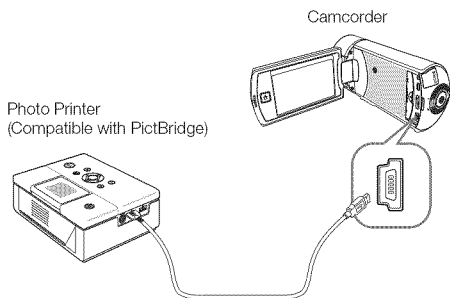

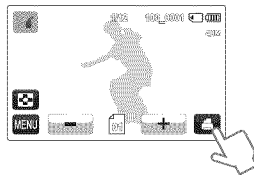

- 3 Turn your printer on.
 - The photo thumbnails appear on the LCD screen.
- 4 Touch the photos you want to print, and then touch the Print  tab.
 - The corresponding message appears.



- 5 Touch "Yes".
 - The selected photo is printed.

To set the number of prints

Touch the decrease ()/increase () tab to set the number of copies to print.

- The number of copies is set.

To cancel the print setting

Touch the Thumbnail view () tab on the LCD screen.

To stop printing after printing starts

Touch "Cancel" on the screen.

-  • If the camcorder fails to recognize the printer, remove the USB cable, and then turn off the printer. Set "USB Connect" to "PictBridge", and then connect the USB cable again.
- Use the supplied USB cable.

To set the date/time imprint for Pictbridge printers

- 1 In the printer mode, touch the MENU (MENU) tab → "Date/Time".

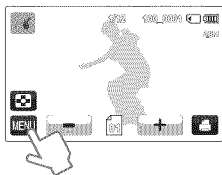

- 2 Touch the desired submenu item.
 - The selected date and time display option is set.

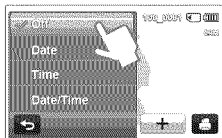

- 3 To exit the menu, touch the Return (RETURN) tab.
 - The selected date and time will be printed on photos.



- The date/time imprint option may not be supported by all printers. Check with your printer manufacturer. The date/time imprint option cannot be setup if the printer does not support the option.
- PictBridge™ is a registered trademark of CIPA (Camera & Imaging Products Association), an image transfer standard developed by Canon, Fuji, HP, Olympus, Seiko Epson, and Sony.
- Use the AC power adaptor to power the camcorder during PictBridge printing. If the camcorder shuts off during printing, it might damage data on the storage media.
- You cannot print video images.
- You cannot print photos recorded on other devices.
- Various printing options are available depending on the printer. Refer to the printer's user manual for details.

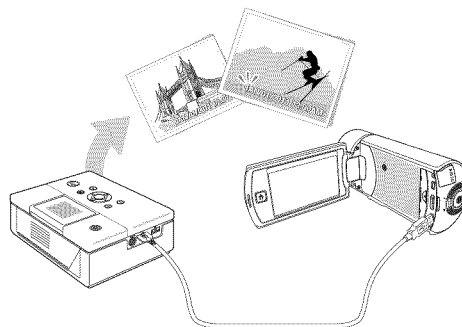

Using with a Windows computer

WHAT YOU CAN DO WITH A WINDOWS COMPUTER

You can perform the following functions by connecting your camcorder to your Windows computer with a USB cable and using the Intelli-studio editing software built into your camcorder.

Main function

- Intelli-studio editing software's main functions.
 - Playing back recorded videos or photos.
 - Editing recorded videos or photos.
 - Uploading the recorded videos and photos to YouTube, Flickr, Facebook, etc.
- You can transfer or copy the files (videos and photos) saved on the storage media into your computer. (the mass storage function)

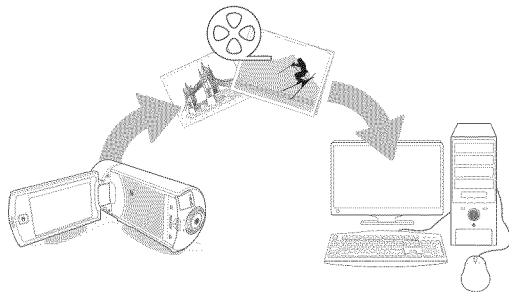

System requirements

The following requirements must be satisfied to use the internal editing software (Intelli-studio):

| Items | Requirement |
|-------------|--|
| OS | Microsoft Windows XP SP2, Vista, or Windows 7 |
| CPU | Intel® Core 2 Duo® 1.66 GHz or higher is recommended AMD Athlon™ X2 Dual-Core 2.2 GHz or higher is recommended (Notebook: Intel Core2 Duo 2.2GHz or AMD Athlon X2 Dual-Core 2.6GHz or higher is recommended) |
| RAM | 1GB or higher is recommended |
| Video Card | NVIDIA GeForce 8500 or higher, ATI Radeon HD 2600 series or higher |
| Display | 1024 x 768, 16-bit color or higher (1280 x 1024, 32-bit color recommended) |
| USB | USB 2.0 |
| Direct X | DirectX 9.0c or higher |
| Memory Card | A SDHC card of Class 6 or above |



- System requirements mentioned above are recommendations. Even on a system that satisfies the requirements, Intelli-studio may not operate optimally.
- On a slower computer than recommended, video playback may skip frames or operate unexpectedly.
- If the version of DirectX on your computer is lower than 9.0c, install DirectX 9.0c or higher.
- We recommend transferring the recorded videos to a PC before playing back or editing the video data.
- To run Intelli-studio, a laptop computer requires better and faster components than a desktop PC.
- Intelli-studio is not Mac OS compliant.

USING THE Intelli-studio PROGRAM

Intelli-studio is a built-in program that allows you to play back and edit files. You can upload files to web sites, such as YouTube or Flickr. For details, select **"Help"** → **"Help"** on the Intelli-studio screen.

Step 1. Connecting the USB cable

- 1 Set **"USB Connect: Mass Storage"** and **"PC Software: ON"**.
→ page 70
 - These are the default settings.
- 2 Connect the camcorder to a PC with the USB cable.
 - A new file saving window appears along with the Intelli-studio main window. If your camcorder has no new files, the pop-up window for saving new files will not appear.
 - Depending on your version of Windows, the Windows removable disk window may also appear.

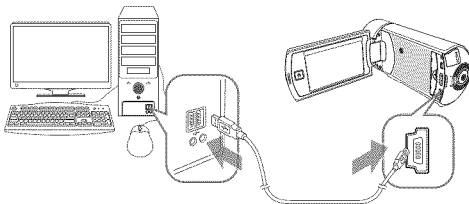

- 3 Click **"Yes"** in the new file saving window. The uploading procedure starts. Click **"Yes"** to confirm.
 - If you do not want to save any new files, select **"No"**.



 To disconnect the USB cable

To disconnect the USB cable after completing the file transfer, you must follow these steps:



1. Click the **"Safely Remove Hardware"** icon on the taskbar.
2. Select **"USB Mass Storage Device"**, and then click **"Stop"**.
3. If the **"Stop a Hardware device"** window appears, click **"OK"**.
4. Disconnect the USB cable from the camcorder and PC.

- Use the provided USB cable. (Supplied by Samsung)
- Make sure you insert the USB plug into the USB jack with the plug facing in the correct direction.
- Use the AC power adaptor to power the camcorder when transferring files to your computer.
- When the USB cable is connected, turning the camcorder on or off may cause the PC to malfunction.
- If you disconnect the USB cable from the PC or the camcorder while transferring files, the data transmission will stop and the data may be damaged.
- If you connect the camcorder to a PC via a USB HUB or simultaneously connect the camcorder along with other USB devices, the camcorder may not work properly. If this occurs, remove all USB devices from the PC, and then reconnect the camcorder.
- Intelli-studio may not automatically run. If this occurs, access My Computer or Windows Explorer, open the drive that corresponds to your camcorder, find Intelli-studio, and then run iStudio.exe.

Step 2. About the Intelli-studio main window

When the Intelli-studio starts up, video and photo thumbnails appear in the main window.

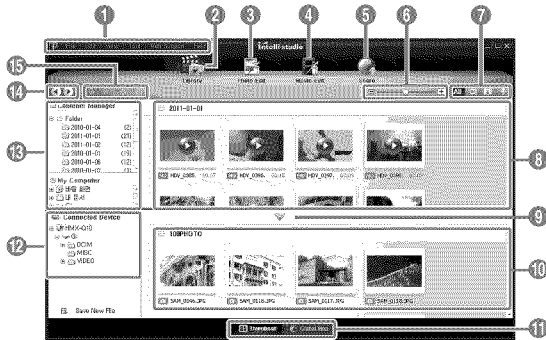

| No. | Description |
|-----|---|
| 1 | Menu items |
| 2 | Display files in the selected folder. |
| 3 | Switch to Photo edit mode. |
| 4 | Switch to Video edit mode. |
| 5 | Switch to Share mode. |
| 6 | Enlarge or reduce the thumbnails in the list. |
| 7 | Select a file type. |
| 8 | View videos and photos of the selected folder on your computer. |
| 9 | Show or hide videos and photos of the connected device. |
| 10 | View videos and photos of the selected folder on the device. |
| 11 | View files as thumbnails or on a map |
| 12 | Browse folders in the connected device. |
| 13 | Browse folders stored on your computer |
| 14 | Move to the previous or next folder |
| 15 | Print files, view files on a map, store files in Contents Manager, or register faces. |



- If you install Intelli-studio on your PC, the program will launch more quickly. To install the program, select **"Tool"** → **"Install Intelli-studio on PC"**.
- If you install the full version of Intelli-studio software, you can use various functions. Start the installation by clicking on **"Web Support"** → **"Update Intelli-studio"** → **"Start Update"**.
- You can update the firmware of this product by selecting **"Web Support"** → **"Upgrade firmware for the connected device"** from the program toolbar.
- The camcorder's built-in Intelli-studio software is intended for home use. It is not for precision or industrial productions. For these applications, we recommend an editing software designed for professional use.

Step 3. Playing back videos or photos

You can play back the recordings conveniently using the Intelli-studio application.

- 1 With Intelli-studio, click the desired folder to display your recordings.
 - Video or photo thumbnails appear on the screen, depending on the folder you selected.
- 2 Choose the video or photo that you want to play back.
 - You can view the file information by moving the mouse over the file.
 - If you click a video thumbnail once, the video plays back inside the thumbnail frame, allowing you to search for a desired scene with ease.
- 3 After you select the video or photo you want, double-click to play back.
 - Playback starts and the controls appear.



-  Intelli-studio supports the following file formats:
- Video formats: MP4 (Video: H.264, Audio: AAC), WMV (WMV 7/8/9)
 - Photo formats: JPG, GIF, BMP, PNG, TIFF

Step 4. Editing videos or photos

You can edit the videos or photos in various ways with various functions. (Change Size, Fine-Tuning, Image Effect, Insert Frame, etc.) Before editing a video or photo in Intelli-studio, make a backup copy of the video or photo file and store it on your computer for safe-keeping using My Computer or Windows Explorer.

- 1 Choose the videos or photos you want to edit.
- 2 Click "**Movie Edit**" or "**Photo Edit**" according to the selected file on the Intelli-studio browser.
 - The selected file appears in the editing window.
- 3 Edit a video or photo with various edit functions.



Step 5. Sharing the videos/photos online

Share your contents with the world by uploading photos and videos directly to a web site with one click.

- 1 Choose the videos or photos you want to share.
- 2 Click **"Share"** on the Intelli-studio browser.
 - The selected file appears in the sharing window.

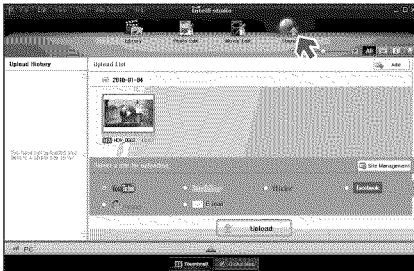

- 3 Click the web site you would like to upload files to.
 - You can choose "YouTube", "twitter", "Flickr", "Facebook", "Picasa", "Email", or another web site you want to use for your site management.

- 4 Click **"Upload"** to start uploading.
 - A pop up window appears asking for your ID and password.



- 5 Enter your ID and the password to access.
 - Access to the web site contents can be limited depending on your web access environment.
-  The recording time and capacity available for uploading videos can be changed depending on each web site's policy.

USING AS A REMOVABLE STORAGE DEVICE

You can copy video or photo files recorded by the camcorder to a Windows computer by connecting the camcorder to the computer using a USB cable.

Viewing the contents of storage media

- 1 Set **"USB Connect"** to **"Mass Storage"**. ➔ page 70
- 2 Set **"PC Software"** to **"OFF"**. ➔ page 70
- 3 Insert a memory card. ➔ page 30
- 4 Connect the camcorder to the PC with the USB cable.
➔ page 87
 - The **"Removable Disk"** or **"Samsung"** window appears on the PC's screen after a moment.
 - Select **"Open folders to view files using Windows Explorer"**, and then click **"OK"**.

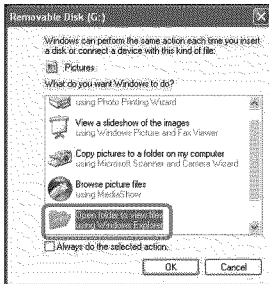

- 5 The folders in the storage media appear.
 - Different file types are stored in different folders.

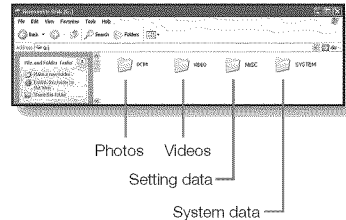

- 6 Select the desired folder or files to copy, then drag and drop them into the destination folder.
 - The folder or files are copied from the storage media to the PC.
- If the **"Removable Disk"** window does not appear, confirm the connection (➔ page 87) or perform steps 1 to 4 again. If the removable disk does not appear automatically, open the removable disk folder in My Computer.
- If the connected camcorder's disk drive does not open or the context menu that appears when right clicking your mouse (open or browse) appears broken, your computer may be infected by Autorun virus. Please update your anti-virus software to its latest version and scan your disk drives.

Structure of folders and files on the storage media

- The folder and file structure for storage media are below.
- File naming follows DCF (Design rule for Camera File System) rules.

Video file (H.264) ①

- HD-quality videos have an HDV_####.MP4 name format.
- SD-quality videos have a SDV_####.MP4 name format.
- The file number used in the file name automatically increases when you create a new video file.
- A new folder is created when the file number has reached 999~1,000.
- The folder names are given in the following order: 100VIDEO, 101VIDEO, etc. The maximum number of folders is 999.
- The camcorder can create a maximum of 9,999 files in a storage media.

Photo file ②

- As with video files, the file number used in the file name automatically increases when you create a new photo file.
- Photos have a SAM_####.JPG name format.
- The folder names are given in the following order: 100PHOTO, 101PHOTO, etc.

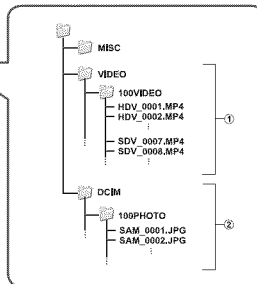
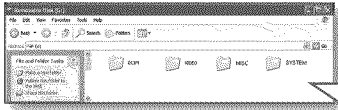

File format

Video files

- Video files are compressed in H.264 format. The file extension is “.MP4”.
- Refer to page 63 for the video resolution.

Photo files

- Photo images are compressed in JPEG (Joint Photographic Experts Group) format. The file extension is “.JPG”.
- Refer to page 63 for the photo resolution.



Do not modify the name of a video file recorded by the camcorder. For proper playback, the camcorder requires that files have their original folder and file names.

Troubleshooting

Before contacting a Samsung authorised service center, perform the following simple checks. They may save you the time and expense of an unnecessary call.





WARNING INDICATORS AND MESSAGES

Problems may occur because of the following reasons. Check the information and take corrective action.



Battery

| Message | Icon | Informs that... | Action |
|------------------------------------|------|---|--|
| Low Battery | - | The battery is almost discharged. | <ul style="list-style-type: none">• Replace with a charged battery or connect the AC power adaptor. |
| Check authenticity of the battery. | - | The battery cannot pass authenticity check. | <ul style="list-style-type: none">• Check whether the battery is authentic. If not, change to an authentic Samsung battery.• We recommend you use only genuine Samsung batteries in this camcorder. |

Storage media

| Message | Icon | Informs that... | Action |
|-------------|---|--|--|
| Insert Card |  | There is no memory card inserted in the memory card slot. | <ul style="list-style-type: none">• Insert a memory card. |
| Card Full |  | There is not enough space to record on the memory card. | <ul style="list-style-type: none">• Delete unnecessary files from the memory card.• Back-up files to a PC or another storage media, and then delete unneeded files.• Replace the memory card with another card that has enough free space. |
| Card Locked |  | The write protection tab on an SD or SDHC card has been set to lock. | <ul style="list-style-type: none">• Release the write protection tab. |
| Card Error |  | The memory card has a problem and the camcorder cannot recognize it. | <ul style="list-style-type: none">• Replace the memory card with another card. |

Storage media

| Message | Icon | Informs that... | Action |
|---|---|---|---|
| Not Formatted |  | The memory card is not formatted in this camcorder. | <ul style="list-style-type: none"> Format the memory card using this camcorder. |
| Not Supported Format |  | The memory card may have been formatted by another device and may still have existing images on it. | <ul style="list-style-type: none"> Files cannot be played as the memory card format is not supported by the camcorder. Format the card using the camcorder or replace the card with a card formatted correctly. |
| Not Supported Card |  | The memory card is not supported in this camcorder. | <ul style="list-style-type: none"> Replace the memory card with a recommended card. |
| Low Speed Card. Please record at a lower resolution. | - | The memory card is not fast enough to record at this resolution. | <ul style="list-style-type: none"> Record video at a lower resolution and quality. Replace memory card with a faster card. |

Recording

| Message | Icon | Informs that... | Action |
|---|------|--|--|
| Write Error | - | Some problem occurred while writing data to storage media. | <ul style="list-style-type: none"> Turn the camcorder's power off and on for data recovery. If a file is not recovered, use the camcorder to format the storage media after backing up important files to a PC or another storage media. |
| Recovering Data... Don't power off and keep card inside. | - | The file was not created normally. | <ul style="list-style-type: none"> Wait until data recovery is finished. Never turn off the power or eject memory card during recording. |

Recording

| Message | Icon | Informs that... | Action |
|---|---|---|---|
| The number of video files is full. Cannot record video. | - | The number of video files that can be stored is 9,999. | <ul style="list-style-type: none"> • Delete unnecessary files from the storage media. • Back up files to your PC or another storage media and delete files. • Change to another card which has enough free space. • Set "File No." to "Reset". • Format the storage media. |
| The number of photo files is full. Cannot take a photo. | - | The number of photo files that can be stored is 9,999. | <ul style="list-style-type: none"> • Delete unnecessary files on the storage media. • Back up files to your PC or another storage media and delete files. • Change to another card which has enough free space. • Set "File No." to "Reset". • Format the storage media. |
| File number is full. Cannot record video. | - | Folder and file number have reached the maximum number and you cannot record. | <ul style="list-style-type: none"> • Set "File No." to "Reset" and format the storage media. Remember to back up important files before formatting. |
| File number is full. Cannot take a photo. | - | Folder and file number have reached the maximum number and you cannot record. | <ul style="list-style-type: none"> • Set "File No." to "Reset" and format the storage media. Remember to back up important files before formatting. |
| Check the lens cover |  | Lens cover is closed. | <ul style="list-style-type: none"> • Open the lens cover. |

Playback

| Message | Icon | Informs that... | Action |
|----------------|------|---|---|
| Read Error | - | A problem has occurred while the camcorder was reading data from the storage media. | <ul style="list-style-type: none"> Use the camcorder to format the storage media after backing up important files to a PC or another storage device. |
| Corrupted file | - | This file cannot be read. | <ul style="list-style-type: none"> Use the camcorder to format the storage media after backing up important files to a PC or another storage device. |

Editing videos

| Message | Icon | Informs that... | Action |
|-------------------------------------|------|--|---|
| Cannot select different resolution. | - | The files you want to combine have different resolutions. | <ul style="list-style-type: none"> You cannot combine files that have different resolutions. |
| Not enough free space in Card. | - | You cannot edit due to insufficient space on memory card. | <ul style="list-style-type: none"> Edit after deleting unnecessary files. |
| Select 2 files for combine. | - | Only two files can be combined. | <ul style="list-style-type: none"> Combine two files first, and then combine the resulting file with an additional file. Note that you cannot combine files if the total size of the combined files exceeds 1.8GB. |
| Total file size is over than 1.8GB. | - | The files whose total size is likely to exceed 1.8GB cannot be combined. | <ul style="list-style-type: none"> Perform a divide or partial delete function first to delete unnecessary parts of the files, and then perform the combine function. |

USB

| Message | Icon | Informs that... | Action |
|---|------|--|---|
| Fail Printer Connecting Change 'USB Connect' | - | A problem occurred when connecting the camcorder via USB to a printer. | <ul style="list-style-type: none"> • Check the USB cable. • Try the connection procedure again. • Switch "USB connect" function to "PictBridge". |
| Fail USB Connecting Change 'USB Connect' | - | A problem occurred when connecting the camcorder via USB to a PC. | <ul style="list-style-type: none"> • Check the USB cable. • Try the connection procedure again. • Switch "USB connect" function to "Mass Storage". |
| Ink Error | - | There is a problem with an ink cartridge. | <ul style="list-style-type: none"> • Check the ink cartridge. • Put a new ink cartridge into the printer. |
| Paper Error | - | There is a problem with the paper. | <ul style="list-style-type: none"> • Check the paper in the printer. If there is no paper, insert paper. |
| File Error | - | There is a problem with the file. | <ul style="list-style-type: none"> • Your camcorder does not support this file format. • Try another file recorded on your camcorder. |
| Printer Error | | There is a problem with the printer. | <ul style="list-style-type: none"> • Turn the printer's power off and on. • Contact the printer manufacturer's service center. |
| Print Error | - | A problem occurred during printing. | <ul style="list-style-type: none"> • Do not remove power source or eject memory card during printing. |

SYMPTOMS AND SOLUTIONS

If these instructions do not solve your problem, contact your nearest Samsung authorized service center.

Power

| Symptom | Explanation/Solution |
|------------------------------------|---|
| The camcorder does not turn on. | <ul style="list-style-type: none"> The battery may not be installed in your camcorder. Insert the battery into the camcorder. The inserted battery may be discharged. Charge the battery or replace it with a charged one. If you use the AC power adaptor, make sure it is properly connected to a wall outlet. |
| The power turns off automatically. | <ul style="list-style-type: none"> Is “Auto Power Off” set to “5 Min”? If no button is pressed for about 5 minutes, the camcorder is automatically turned off (“Auto Power Off”). To disable this option, change the setting of “Auto Power Off” to “Off”. ➔ page 75 The battery is almost exhausted. Charge the battery or replace it with a charged one. |
| Power cannot be turned off. | <ul style="list-style-type: none"> Remove the battery or unplug the AC power adaptor, and connect the power supply to the camcorder again before turning it on. |
| The battery discharges quickly. | <ul style="list-style-type: none"> The temperature is too low. The battery is not fully charged. Charge the battery again. The battery has reached the end of its lifespan and cannot be recharged. Use another battery. |

Display

| Symptom | Explanation/Solution |
|--|--|
| The TV screen or LCD display has distorted images or has stripes at the top/bottom or on the left/right. | <ul style="list-style-type: none"> This can occur when recording or viewing a 16:9 ratio image on a 4:3 ratio TV, or vice versa. For more details, see the display specification. ➔ page 82 |
| Unknown image appears on the LCD screen. | <ul style="list-style-type: none"> The camcorder is in Demo mode. If you do not want to see Demo images, change the setting “Demo” to “OFF”. ➔ page 79 |
| Unknown indicator appears on the screen. | <ul style="list-style-type: none"> A warning indicator or message appears on the screen. ➔ pages 93-97 |

Display

| Symptom | Explanation/Solution |
|--|--|
| An afterimage remains on the LCD screen. | <ul style="list-style-type: none"> This occurs if you disconnect the AC power adaptor or remove the battery before turning the power off. |
| The image on the LCD screen looks dark. | <ul style="list-style-type: none"> Ambient light is too bright. Adjust the brightness and angle of the LCD. |

Recording

| Symptom | Explanation/Solution |
|---|---|
| Pressing the Recording start/stop button does not start recording. | <ul style="list-style-type: none"> Set your camcorder to the recording mode. ▶ page 26 There is not enough free space to record on the storage media. Check if memory card is not inserted or write-protect tab is set to lock. |
| The actual recording time is less than the estimated recording time. | <ul style="list-style-type: none"> The estimated recording time may vary depending on content and features used. When you record an object that moves fast, the actual recording time may be shortened. |
| The recording stops automatically. | <ul style="list-style-type: none"> There is no more free space for recording on the storage media. Back up important files on your PC and format the storage media or delete the unnecessary files. If you make recordings or delete files frequently, the performance of the storage media deteriorates. If this occurs, format the storage media again. If you use a memory card with low writing speed, the camcorder automatically stops recording videos and a corresponding message appears on the LCD screen. |
| When recording a subject illuminated by bright light, a vertical line appears. | <ul style="list-style-type: none"> This is not a malfunction. |
| When the screen is exposed to direct sunlight during recording, the screen becomes red or black for an instant. | <ul style="list-style-type: none"> This is not a malfunction. |
| During recording, the date/time does not display. | <ul style="list-style-type: none"> "Date/Time Display" is set to "Off". Set the "Date/Time Display" to On. ▶ page 68 |
| You cannot record a photo image. | <ul style="list-style-type: none"> Set your camcorder to the photo recording mode. ▶ page 26 Release the lock on the write-protection tab of the memory card if any. The storage media is full. Use a new memory card or format the storage media. ▶ page 77 Or remove unnecessary images. ▶ page 58 |

Recording

| Symptom | Explanation/Solution |
|--|---|
| You don't hear the shutter sound when you record a photo image. | <ul style="list-style-type: none"> Set "Shutter Sound" to "ON". When the Mini HDMI cable or Audio/Video cable is connected to the camcorder, the Shutter Sound is not available. |
| You don't hear the beep sound. | <ul style="list-style-type: none"> Set "Beep Sound" to "ON". Beep sound is temporarily off while recording videos. When the Mini HDMI cable or Audio/Video cable is connected to the camcorder, the Beep Sound is not available. |
| There is a time difference between the point where you press the Recording start/stop button and the point where the recorded video starts/stops. | <ul style="list-style-type: none"> On your camcorder, there may be a slight time delay between the point when you press the Recording start/stop button and the actual point where the recorded video starts/stops. This is not an error. |
| Horizontal stripes appear on the images. | <ul style="list-style-type: none"> This occurs when recording images under a fluorescent lamp, sodium lamp, or mercury lamp. This is not a malfunction. |

Storage Media

| Symptom | Explanation/Solution |
|--|--|
| Memory card functions do not operate. | <ul style="list-style-type: none"> Insert a memory card into your camcorder properly. ↪ page 30 If you use a memory card formatted on a computer, format it again directly on your camcorder. ↪ page 77 |
| Image cannot be deleted. | <ul style="list-style-type: none"> Release the lock on the write-protect tab of the memory card (SDHC/SD memory card), if any. ↪ page 31 You cannot delete a protected images. Release protection of the image using the Protect function. ↪ page 59 |
| You cannot format the memory card. | <ul style="list-style-type: none"> Release the lock on the write-protect tab of the memory card (SDHC/SD memory card), if any. ↪ page 31 The memory card is not supported on your camcorder or card has some problems. |
| The data file name is not indicated correctly. | <ul style="list-style-type: none"> The file may be corrupted. The file format is not supported by your camcorder. Only the file name is displayed if the directory structure complies with the international standard. |

Adjusting the image during recording

| Symptom | Explanation/Solution |
|---|--|
| Focus does not adjust automatically. | <ul style="list-style-type: none"> Set "Focus" to "Auto". (Video recording mode only) ➤page 53 The recording conditions are not suitable for auto focus. Adjust the focus manually. (Video recording mode only) ➤page 53 The lens is dusty on the surface. Clean the lens and check the focus. Recording is being made in a dark location. Use a light to brighten the area. |
| Image's color balance is not natural. | <ul style="list-style-type: none"> The white balance is incorrect. Set the proper "White Balance". ➤page 50 |
| A subject passing quickly through the frame appears distorted | <ul style="list-style-type: none"> This is called the focal plane phenomenon. This is not a malfunction. Because of the way the image device (CMOS sensor) reads out video signals, a subject passing through a frame rapidly may appear to bend, depending on the recording conditions. |

Playback on your camcorder

| Symptom | Explanation/Solution |
|--|---|
| Playback (playback/pause) function does not work. | <ul style="list-style-type: none"> Image files recorded using another device may not play back on your camcorder. Check memory card compatibility. ➤page 31 |
| Photo images stored on a storage media are not displayed in the actual size. | <ul style="list-style-type: none"> Photo images recorded on other devices may not appear in their actual size. This is not an error. |
| Playback is interrupted unexpectedly. | <ul style="list-style-type: none"> Check if the AC power adaptor or battery back is properly connected and secure. |

Playback on other devices (TV, etc.)

| Symptom | Explanation/Solution |
|--|---|
| You cannot view the image on or hear the sound from the connected device. | <ul style="list-style-type: none"> Make sure that the connection cable is connected to the proper jack. |
| The image appears distorted on a TV. | <ul style="list-style-type: none"> This phenomenon is caused by connecting to a TV with 4:3 aspect ratio. |
| You cannot view the image on or hear the sound from a TV connected using the HDMI cable. | <ul style="list-style-type: none"> The camcorder cannot output images from the HDMI jack if the material is copyright protected. |

Connecting/Dubbing with other devices (Recorder, PC, Printer, etc.)

| Symptom | Explanation/Solution |
|--|---|
| You cannot dub correctly using the HDMI cable. | <ul style="list-style-type: none"> You cannot dub images using the HDMI cable. |
| You cannot dub correctly using the Audio/Video cable. | <ul style="list-style-type: none"> The Audio/Video cable is not connected properly. Make sure that the Audio/Video cable is connected to the proper jack, i.e. to the input jack of the device used for dubbing images from your camcorder. ➤page 83 |
| Your PictBridge printer cannot print photos from your camcorder. | <ul style="list-style-type: none"> Your printer may not print images edited on a computer or recorded using other devices. This is not an error. |

Connecting to a computer

| Symptom | Explanation/Solution |
|--|---|
| Your computer does not recognize your camcorder. | <ul style="list-style-type: none"> Disconnect the USB cable from the computer and camcorder, restart the computer, and then connect the USB cable again correctly. |
| Cannot play back a video file properly on a PC. | <ul style="list-style-type: none"> You need a video codec to play back the file recorded on your camcorder. Install the software provided with your camcorder. ➤page 88 Make sure you insert the connector in the correct direction, and connect the USB cable to the USB jack on your camcorder firmly. Disconnect the cable from the computer and camcorder, restart the computer, and then connect the cable again properly. To play back an HD video file, you need a computer with better specifications. Use a computer with the recommended specifications. ➤page 86 |
| Intelli-studio does not function properly. | <ul style="list-style-type: none"> Exit the Intelli-studio application, and restart the Windows computer. |
| Intelli-studio does not start. | <ul style="list-style-type: none"> Set "PC Software" to "ON" in the Settings menu or install Intelli-studio on the computer. ➤pages 70, 88 |

Connecting to a computer

| Symptom | Explanation/Solution |
|---|---|
| Your computer is not playing videos, images, or sound located on your camcorder properly. | <ul style="list-style-type: none"> • Video playback or sound may stop temporarily depending on your computer. The video or sound copied to your computer is not affected. • If your camcorder is connected to a computer that does not support Hi-speed USB (USB2.0), the image or sound may not play back correctly. Images, video, and sound copied from the camcorder to your computer are not affected. |
| The playback screen is paused or distorted. | <ul style="list-style-type: none"> • Check the system requirements to play a video. • Shut down all other applications currently running on the computer. • If you play back a video on your camcorder when it is connected to a computer, the video may not play back smoothly on the computer, depending on the transfer speed. Please copy the file to your PC, and then play it back. |

Overall operations

| Symptom | Explanation/Solution |
|----------------------------------|---|
| The date and time are incorrect. | <ul style="list-style-type: none"> • Has the camcorder been left unused for a long period of time? The backup internal rechargeable battery may be discharged. ➔ page 28 |

Additional information

MAINTENANCE

The suggestions below will help you fulfill any warranty obligations and allow you to enjoy this product for many years.

Cautions when storing

- For safekeeping of the camcorder, turn off the camcorder.
 - Remove the battery.
 - Remove the memory card.

Cleaning the camcorder

Before cleaning, turn off the camcorder and remove the battery.

- **To clean the exterior**
 - Wipe gently with a soft dry cloth. Do not apply excessive force when cleaning. Gently rub the surface.
 - Do not use benzene or thinner to clean the camcorder. The exterior coating could peel off or the case could deteriorate.
- **To clean the LCD screen**

Wipe very gently with a soft dry cloth. Be careful not to damage the screen.

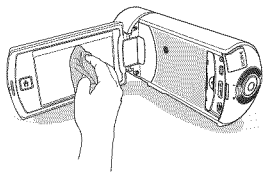

- **To clean the lens**

Use a blower brush to remove dust, and then wipe the lens gently with a soft cloth.

If necessary, wipe gently with lens paper or tissue.

- Mold may form if the lens is left dirty.
- If the lens looks dim, turn off the camcorder and leave it off for about 1 hour.

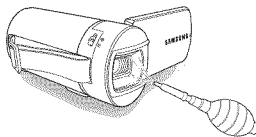

LCD screen

- To prolong its service life, do not rub the LCD screen with a coarse cloth.
- Be aware of the following LCD screen phenomena. They are not malfunctions.
 - When you use the camcorder, the surface around the LCD screen may heat up.
 - If you leave the power on for a long time, the surface around the LCD screen becomes hot.
 - When using the camcorder in cold conditions, an afterimage may appear on the LCD screen.
- An LCD screen is manufactured using advanced technology which creates screens with pixel failure rates of less than 0.01%. However, a black or bright spot (red, blue, white) may appear in the center of the LCD screen and up to two spots may appear outside the center. These spots, which are normally incurred during the manufacturing process, do not affect the recorded images.



When there is dew condensation, put the camcorder aside for a while before using.

- **What is dew condensation?**

Dew condensation happens when a camcorder is moved to a location where there is a significant temperature difference from the previous location. The dew condenses on the external or internal parts of the camcorder, and on the reflection lens. If there is dew on or in your camcorder, it may cause the camcorder to malfunction or damage the camcorder when you turn the power on.

- **Exactly when does dew condensation occur?**

When you move the camera to a location with a higher temperature than the previous location, or when you move it to a hot area suddenly. Examples:

- You record outside in cold weather during the winter and then move the camera indoors.
- You record outside in hot weather after being indoors or inside a car where the A/C was running.

- **What can I do?**

- Turn the power off, detach the battery, and leave the camcorder in a dry area for 1~2 hours before using it.



- Use the camcorder only after dew condensation has completely disappeared.
- Be sure to use the recommended accessories supplied with the camcorder. For service, contact your nearest Samsung authorized service center.

USING YOUR CAMCORDER ABROAD

- Each country or region has its own electric and color systems.
- Before using your camcorder abroad, check the following items.

Power sources

The AC adaptor provided lets you power, recharge, and use your camcorder in any country/region that has AC power in the 100 V to 240 V, 50/60 Hz range. You may need a commercially available AC plug adaptor depending on the design of local wall outlets.

On TV color systems

Your camcorder is an NTSC based camcorder. If you want to view your recordings on a TV or copy them to an external device, it must be an NTSC based TV or external device and have the appropriate Audio/Video jacks. Otherwise, you may need to use a separate video format transcoder (For example, an NTSC to PAL format converter).



The format transcoder is not provided by Samsung.

NTSC-compatible countries/regions

Bahamas, Canada, Central America, Japan, Korea, Mexico, Philippines, Taiwan, United States of America, etc.

PAL-compatible countries/regions

Australia, Austria, Belgium, Bulgaria, China, CIS, Czech Republic, Denmark, Egypt, Finland, France, Germany, Greece, Great Britain, Holland, Hong Kong, Hungary, India, Iran, Iraq, Kuwait, Libya, Malaysia, Mauritius, Norway, Romania, Saudi Arabia, Singapore, Slovak Republic, Spain, Sweden, Switzerland, Syria, Thailand, Tunisia, etc.



You can make recordings with your camcorder and view pictures on the LCD screen anywhere in the world.

GLOSSARY

AF (Auto Focus)

A system that automatically focuses the camcorder lens on the subject. Your camcorder uses the contrast to focus automatically.

Aperture

The aperture controls the amount of light that reaches the camcorder's sensor.

Camcorder shake (Blur)

If the camcorder is moved while the shutter is open, the entire image may appear blurred. This occurs more often when the shutter speed is slow. Prevent camcorder shake by raising the sensitivity, using a faster shutter speed. Alternately, use a tripod, the DIS or OIS function to stabilize the camcorder.

Composition

Composition in photography means arranging objects in a photo. Usually, abiding by the rule of thirds leads to a good composition.

Complementary Metal-Oxide-Semiconductor (CMOS)

CMOS is an image sensor producing images approaching the quality of CCD (charge coupled device) sensors. It consumes less power, meaning a longer battery life on your camcorder.

Digital zoom

A feature that artificially increases the amount of zoom available with zoom lens (Optical zoom). When using the Digital zoom, the image quality will deteriorate as the magnification increases.

Effective Pixel Count

Unlike the total pixel count, this is the actual number of pixels used to capture an image.

EV (Exposure Value)

All the combinations of the camcorder's shutter speed and lens aperture that result in the same exposure.

Exposure

The amount of light allowed to reach the camcorder's sensor. Exposure is controlled by a combination of the shutter speed, the aperture value, and ISO sensitivity.

Focal length

The distance from the middle of the lens to its focal point (in millimeters). Longer focal lengths result in narrower angles of view and the subject is magnified. Shorter focal lengths result in wider angles of view.

F. No (F-Number)

The f-number defines the brightness of lens. Smaller number lens has generally brighter image. The f-number is directly proportional to the focal length and inversely proportional to the lens diameter.

*F.No=focal length/diameter of lens aperture

MPEG-4 AVC/H.264

MPEG-4 AVC/H.264 defines the latest video coding format standardized by the ISO-IEC and the ITU-T, in 2003. Compared with the conventional MPEG-2 format, MPEG-4 AVC/H.264 has more than twice the efficiency. Your camcorder employs MPEG-4 AVC/H.264 to encode high definition videos.

Optical zoom

This is a general zoom which can enlarge images with a lens and does not deteriorate quality of images.

Quality

An expression of the rate of compression used in a digital image. Higher quality images have a lower rate of compression, which usually results in a larger file size.

Resolution

The number of pixels present in a digital image. High resolution images contain more pixels and typically show more detail than low resolution images.

Shutter speed

Shutter speed refers to the amount of time it takes to open and close the shutter, and it is an important factor in the brightness of a photo, as it controls the amount of light which pass through the aperture before it reaches the image sensor. A fast shutter speed allows less time to let light in and the photo becomes darker and more easily freezes subjects in motion.

Tele Macro

This feature allows you to capture close-up images of very small objects. When using the Tele Macro feature, the camcorder can maintain a sharp focus on small objects at a near life-size ratio (1:1).

White balance (color balance)

An adjustment of the intensities of colors (typically the primary colors red, green, and blue), in an image. The goal of adjusting the white balance, or color balance, is to correctly render the colors in an image.

Specifications

| | | |
|--------------|---|--|
| Model name | HMX-Q10BN/HMX-Q10TN/HMX-Q10UN/HMX-Q10PN HMX-Q100BN/HMX-Q100TN/HMX-Q100UN/HMX-Q100PN HMX-Q130BN/HMX-Q130TN/HMX-Q130UN/HMX-Q130PN | |
| System | Video signal | NTSC |
| | Picture compression format | H.264 (MPEG-4,AVC) |
| | Audio compression format | AAC (Advanced Audio Coding) |
| | Image device | 1/4" CMOS |
| | Effective pixels | 2.07 mega pixels |
| | Total pixels | 5.1 mega pixels |
| | Lens | F1.8 ~ F2.5, x10 Optical Zoom, x20 Digital Zoom |
| | Angle of View | 57.27°(W) ~ 6.23°(T) |
| LCD screen | Size/dot number | 2.7" Wide Touch LCD / 230k |
| | LCD screen method | TFT LCD |
| Connectors | Composite output | 1Vp-p (75 Ω terminated) |
| | HDMI output | C type connector |
| | Audio output | -7.5 dBs (600 Ω terminated) |
| | USB output | USB 2.0 |
| General | Power source | DC 5 V, Lithium Ion battery 3.7 V |
| | Power source type | Lithium Ion battery, Power supply (100 V ~ 240 V) 50/60 Hz |
| | Power consumption (Recording) | 2.5W (LCD on) |
| | Operating temperature | 32 °F~104 °F (0 °C ~ 40 °C) |
| | Operating humidity | 40% ~ 60% |
| | Storage temperature | -4 °F ~ 140 °F (-20 °C ~ 60 °C) |
| | Storage media | Memory card (SD/SDHC) (not supplied) |
| | External dimensions (WxHxD) | Approx. 43.7mm (1.72 inches) x 53.3mm (2.1 inches) x119.4mm (4.7 inches) |
| | Weight | Approx. 185.9g (0.41 lb, 6.56 oz) (Except for Lithium Ion battery) |
| Internal MIC | Omni-directional stereo microphone | |

※ The technical specifications and design may be changed without notice.

Warranty

SAMSUNG LIMITED WARRANTY

SAMSUNG Electronics America Inc. (SEA), warrants that this product is free from defective material and workmanship. SEA further warrants that if product fails to operate properly within the specified warranty period and the failure is due to improper workmanship or defective material, SEA will repair or replace the product at it's option. All warranty repairs must be performed by a SEA authorized service center. The name and address of the location nearest you can be obtained by calling toll free: 1-800 SAMSUNG (1-800-726-7864).

Labor
90 days carry-in
Parts
1 year

On carry-in models, transportation to and from the service center is the customer's responsibility. The original dated sales receipt must be retained by the customer and is the only acceptable proof of purchase. It must be presented to the authorized service center.

EXCLUSIONS (WHAT IS NOT COVERED)

This warranty does not cover damage due to accident, fire, flood and/or other acts of God; misuse, incorrect line voltage, improper installation, improper or unauthorized repairs, commercial use, or damage that occurs in shipping. Exterior and interior finish, lamps, and glass are not covered under this warranty. Customer adjustments which are explained in the instruction manual are not covered under the terms of this warranty. This warranty will automatically be voided for any unit found with a missing or altered serial number. This warranty is valid only on products purchased in the United States and Puerto Rico. Some States do not allow the exclusions or limitations of incidental or consequential damages, or allow limitations on how long an implied warranty lasts, so the above limitations or exclusions may not apply to you. This warranty gives you specific legal rights, and you may also have other rights which vary from State to State.



QUESTIONS OR COMMENTS?

| COUNTRY | CALL | OR VISIT US ONLINE AT | WRITE |
|-----------|-----------------------------|--|--|
| IN THE US | 1-800-SAMSUNG (726-7864) | www.samsung.com | Samsung Electronics America, Inc. 85 Challenger Road Ridgefield Park, NJ 07660-2112 |



RoHS compliant

Our product complies with "The Restriction Of the use of certain Hazardous Substances in electrical and electronic equipment", and we

do not use the 6 hazardous materials- Cadmium(Cd), Lead (Pb), Mercury (Hg), Hexavalent Chromium (Cr +6), Poly Brominated Biphenyls (PBBs), Poly Brominated Diphenyl Ethers(PBDEs)- in our products.