

# USE AND CARE MANUAL

---

## DISTINCTIVE SERIES COOKTOP

*For use with models DRT304S and DRT366S*

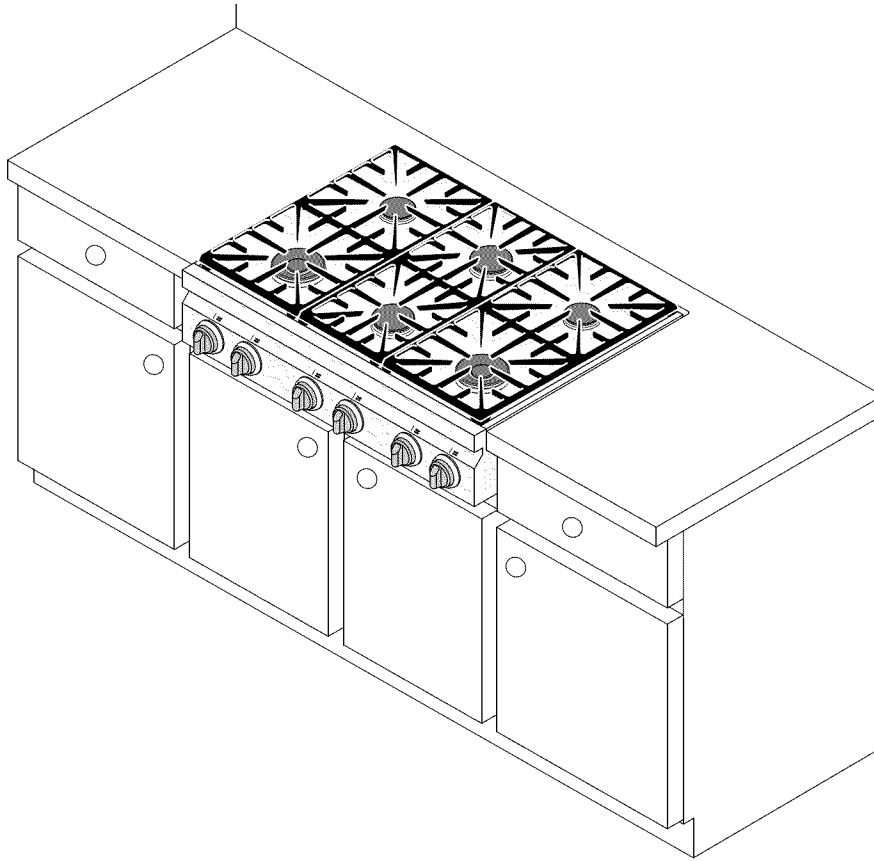

*Style varies, model DRT366S shown*

## TABLE OF CONTENTS

IMPORTANT SAFETY INSTRUCTIONS .....	1-3
GETTING TO KNOW YOUR COOKTOP.....	4
SETTING UP YOUR COOKTOP.....	5
OPERATING YOUR COOKTOP.....	6-7
CARE AND CLEANING.....	8-10
ACCESSORIES AND REPLACEMENT PARTS .....	10
BEFORE YOU CALL FOR SERVICE .....	11
WARRANTY AND SERVICE .....	12
WARRANTY CARD.....	BACK COVER





To Our Valued Customer:

Congratulations on your purchase of the very latest in Dacor® products! Our unique combination of features, style and performance make us The Life of the Kitchen™, and a great addition to your home.

In order to familiarize yourself with the controls, functions, and full potential of your new Distinctive Appliance, we suggest that you thoroughly read this use and care manual, beginning with the **Important Safety Instructions** section.

All Dacor appliances are designed and manufactured with quality and pride, while working within the framework of our company value. Should you ever experience a problem with your product, please first check the **Before You Call for Service** section of this manual for guidance. It provides useful suggestions and remedies prior to calling for service.

Valuable customer input helps us to continuously improve our products and services, so please feel free to contact our Customer Service Team for assistance with any of your product support needs.

Dacor Customer Service Team  
600 Anton Blvd. Suite 1000  
Costa Mesa, CA 92626

Telephone: (800) 793-0093  
Fax: (626) 403-3130  
Hours of Operation: Monday through Friday  
6:00 A.M. to 5:00 P.M. Pacific Time  
Web Site: [www.Dacor.com](http://www.Dacor.com)

Thank you for choosing Dacor for your home. We are a company built by families for families and we are dedicated to serving yours. We are confident that your new Dacor product will deliver a high level of performance and enjoyment for many years to come.

Sincerely,

*The Dacor Customer Service Team*

# Important Safety Instructions

**Installer:** Leave these instructions with the appliance.

**Consumer:** Read this use and care manual completely before using this appliance. Save it for future reference. It contains important use and care information. Keep your sales receipt or canceled check in a safe place. Proof of original purchase date is required for warranty service.

**For service and warranty information, see page 12.**

If you have any questions, call:

Dacor Customer Service

(800) 793-0093 (U.S.A. and Canada)

Monday — Friday 6:00 A.M. to 5:00 P.M. Pacific Time

Web site: [www.Dacor.com](http://www.Dacor.com)

Have the complete model and serial number identification of your cooktop ready. Record these numbers below for easy access. The numbers are found on a label on the under side of the chassis.

Model number \_\_\_\_\_

Serial number \_\_\_\_\_

Date of purchase \_\_\_\_\_

Since Dacor continuously improves the quality and performance of our products, we may need to make changes to the appliance without updating this manual.

## Important Information About Safety Instructions

The **Important Safety Instructions** and warnings in this manual are not meant to cover all possible problems and situations that can occur. Use common sense and caution when installing, maintaining or operating this or any other appliance.

Always contact the Dacor Customer Service Team about problems or situations that you do not understand.

## Safety Symbols and Labels

### **DANGER**

Immediate hazards that **WILL** result in severe personal injury or death.

### **WARNING**

Hazards or unsafe practices that **COULD** result in severe personal injury or death.

### **CAUTION**

Hazards or unsafe practices that **COULD** result in minor personal injury or property damage.

### **DANGER**

**IMPORTANT:** If you smell gas:

- Do not use or light any appliance.
- Do not touch any electrical switch or use any electrical devices including the telephone in your building.
- From a neighbor's phone, immediately call the gas supplier. Follow the gas supplier's instructions.
- If you cannot contact the gas supplier, call the fire department.

**IMPORTANT:** To avoid the possibility of explosion or fire, do not store or use combustible, flammable or explosive vapors and liquids (such as gasoline) in the vicinity of this or any other appliance. Also keep items that could explode, such as aerosol cans away from the cooktop. Do not store flammable or explosive materials in adjacent cabinets or areas.

### **WARNING**

**NEVER** use this appliance as a space heater to heat or warm the room. Doing so may result in carbon monoxide poisoning and overheating of the appliance.

### **WARNING**

**NEVER** cover any slots, holes or passages on the cooktop or cooktop chassis. Doing so blocks air flow through the cooktop and may cause carbon monoxide poisoning. Aluminum foil linings may also trap heat, causing a fire hazard. Keep all slots clear of grease and grime.

### **CALIFORNIA PROPOSITION 65 WARNING**

The burning of gas cooking fuel generates some by-products that are on the list of substances which are known by the State of California to cause cancer or reproductive harm. California law requires businesses to warn customers of potential exposure to such substances. To minimize exposure to these substances, always operate this unit according to the use and care manual, ensuring you provide good ventilation when cooking with gas.

**READ AND SAVE  
THESE INSTRUCTIONS**

# Important Safety Instructions

## General Safety Precautions

To reduce the risk of fire, electric shock, serious injury or death when using your cooktop, follow basic safety precautions, including the following:

### WARNING

- If you receive a damaged product, immediately contact your dealer or builder. Do not install or use a damaged appliance.
- Installations with less than 2 1/2" (64 mm) from the rear of the cooktop to a combustible vertical surface must use Dacor backguard model AEB3009, AEB3012, (for model DRT304S) AEB3609, AEB3612 (for model DRT366S) or a non-combustible material.
- Make sure that the cooktop has been properly installed and grounded by a qualified installer according to the accompanying installation instructions. Have the installer show you the location of the gas shut off valve and the power cord so that you know where and how to turn off the gas supply and disconnect power to the cooktop.
- Do not install, repair or replace any part of the cooktop unless specifically recommended in the literature accompanying it. A qualified service technician should perform all other service.
- Do not tamper with the controls. Do not adjust or alter any part of the cooktop unless specifically instructed to do so in these instructions.
- Before performing any type of service, make sure that the gas supply is turned off and the power cord to the cooktop is disconnected.
- Only use this cooktop for cooking tasks expected of a home appliance as outlined in this manual. This cooktop is not intended for commercial use.
- DO NOT TOUCH THE SURFACES OF THE COOKTOP DURING OR IMMEDIATELY AFTER USE. After use, make sure these surfaces have had sufficient time to cool before touching them.
- Make sure individuals who use the cooktop are able to operate it properly.
- Never allow anyone, including children to sit, stand or climb on any part of the cooktop. Doing so may cause damage, serious injury or death. Do not leave children alone or unattended in the area around the cooktop. Do not allow children to play with the controls or touch other parts of the cooktop.
- Do not store items of interest to children on top of or above the cooktop. Children could be burned or injured while climbing on the appliance.
- Do not attempt to use this appliance in the event of a power failure. If a power failure occurs while operating the cooktop, turn all control knobs to the **OFF** position.

### WARNING

- Do not heat unopened food containers such as baby food jars and cans. Pressure build up may cause the container to burst and cause injury.
- Do not cover the burners and grates with anything except properly selected utensils. Decorative covers may cause a fire hazard or damage to the cooktop if a burner is accidentally turned on with the cover in place.
- Clean the cooktop thoroughly before operating it for the first time.
- Clean and maintain the cooktop regularly as instructed in this manual. Keep the entire cooktop, ventilation filters and ventilation hoods free of grease that could catch fire.
- Keep flammable items, such as paper, cardboard, plastic and cloth away from the burners and other hot surfaces. Do not allow pot holders to touch hot surfaces or gas burners.
- Do not wear loose or hanging apparel while using the cooktop. Do not allow clothing to come into contact with the cooktop and surrounding areas during and immediately after use.
- Do not use towels or bulky cloth as pot holders.
- Do not hang flammable or heat sensitive objects over the cooktop.
- If the cooktop is near a window, do not use long curtains as window treatment. The curtains could blow over the cooktop and create a fire hazard.
- To avoid the possibility of fire, do not leave the cooktop unattended when in use.
- Use cookware only for its intended purpose. Check the manufacture's recommendations before use to determine if a utensil is suitable for use on a cooktop. Certain types of glass, ceramic and earthenware are not suitable for use on a cooktop. Personal injury or damage may result from improper cookware use.
- Select cookware carefully. Use utensils of the proper size, material and construction for the particular type of cooking being done. Utensils need to be large enough to contain the desired quantity of food without boil-overs or spill-overs. Choose pans with easy to hold handles that will stay cool while cooking. Do not use utensils with loose handles. Avoid using pans that are too heavy to lift safely.
- Use extreme caution if adding water to food on a hot cooktop. The steam can cause serious burns or scalds.

# Important Safety Instructions

## WARNING

- Make sure that all the cooktop parts are dry before lighting a burner.
- Turn the knobs to the **OFF** position prior to removing them from the valve stems.
- The cooktop should never be operated without the knobs and trim rings in place.
- Use only dry pot holders when removing food and cookware from the cooktop. Wet pot holders can cause steam burns.
- Non-stick coatings, when heated, can be harmful to birds. Remove birds to a separate, well-ventilated room during cooking.
- When deep fat frying:
  - ◇ Be certain that the pan is large enough to contain the desired volume of food without overflow caused by the bubbling of the fat. Never leave a deep fat fryer unattended.
  - ◇ Avoid frying moist or frost-covered foods. Foods with high water content may cause spattering or spilling of the hot fat.
  - ◇ Heat fat slowly, and stir together any combination of oils and fats prior to applying heat. Utilize a deep fat frying thermometer to avoid heating the fat to temperatures above the flash point.
- This appliance is equipped with a three prong grounding plug for your protection against possible electric shock hazards. If only a two prong outlet is available, it is the customer's responsibility to have it replaced with a dedicated, grounded, three prong electrical outlet by a licensed electrician. Do not under any circumstances:
  - ◇ Cut or remove the third (ground) prong from the power cord.
  - ◇ Use an adapter plug.
  - ◇ Use an extension cord.
  - ◇ Use a power cord that is frayed or damaged.
  - ◇ Plug the cooktop into an electrical outlet with a ground fault interrupter (GFI).

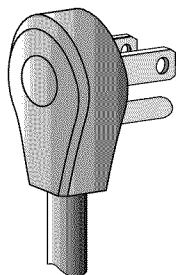

Power cord with three prong grounding plug

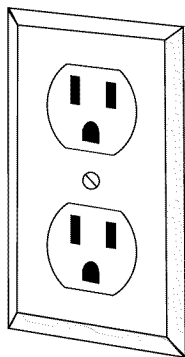

Three prong electrical outlet

## WARNING

- TO REDUCE THE RISK OF INJURY TO PERSONS IN THE EVENT OF A RANGE TOP GREASE FIRE:
- a. **SMOTHER FLAMES** with a close-fitting lid, cookie sheet or metal tray, then turn off the burner. **BE CAREFUL TO PREVENT BURNS.** If the flames do not go out immediately, **EVACUATE AND CALL THE FIRE DEPARTMENT.**
  - b. **NEVER PICK UP A FLAMING PAN** - you may be burned.
  - c. **DO NOT USE WATER**, including wet dish cloths or towels - a violent steam explosion may result.
  - d. Use a fire extinguisher **ONLY** if:
    - ◇ You have a Class ABC extinguisher, and you already know how to operate it.
    - ◇ The fire is small and contained in the area where it started.
    - ◇ The fire department is being called.
    - ◇ You can fight the fire with your back to an exit.

## CAUTION

- Do not allow acids (citrus juices, tomato sauces, etc.) to remain on the cooktop's surfaces. The porcelain finish may stain.
- Never use the cooktop surface as a cutting board.
- Do not try to remove heavy spills with a sharp object such as a knife or metal spatula. Sharp objects may scratch the cooktop's surfaces.
- Do not expose the knobs or trim rings to direct flame, hot utensils or other sources of heat.

# Getting to Know Your Cooktop

## Parts of the Cooktop

**Burners:** The cooktop's flame-less ignition system generates a spark that lights the burner when you turn the knob to **HIGH**. See the diagrams on the right for the size and location of the different burner types.

**Long Life Grates:** The porcelain coated cast iron grates support the cooking utensils during cooking. They are removable to allow the area below and around the burners to be cleaned easily. The size and location of each grate depends on the model of the cooktop.

**Spill Trays:** The spill trays catch any food that falls through the cooktop grates.

**Burner Control Knobs:** Use the knobs to turn on the burners and adjust the flame size. An indicator next to each knob lights when the burner control is on.

**Trim Rings:** Located behind each knob. They prevent liquids from getting into the cooktop's internal parts.

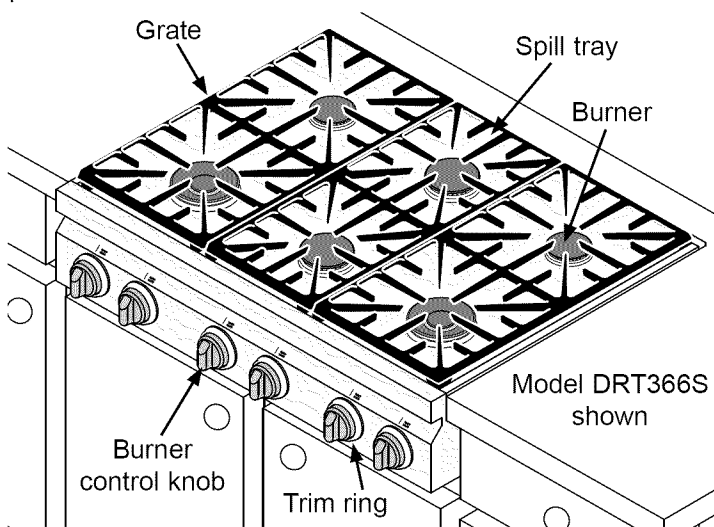

## Special Cooktop Features

**Perma-Flame™:** The Perma-Flame instant re-ignition feature automatically re-lights a burner quickly if it goes out. With Perma-Flame, your cooking experience is uninterrupted because the flame is re-ignited at the same level as when it went out.

**Smart Flame™ Technology:** All burners are equipped with Dacor's Smart Flame technology. It reduces the temperature under the fingers of the porcelain-coated cast iron grates. Smart-Flame extends grate life and protects the finish.

**SimmerSear™ Burners:** Dacor's exclusive precision burner control system. SimmerSear burners have a wider range of heat settings than the standard burners. The wider range allows you precise heat control from simmer to sear (high).

## Burner Locations

- A** Standard Burner: 1300 - 9500 BTU
- B** Standard Burner: 1700 - 15000 BTU
- C** SimmerSear Burner: 800 - 18000 BTU

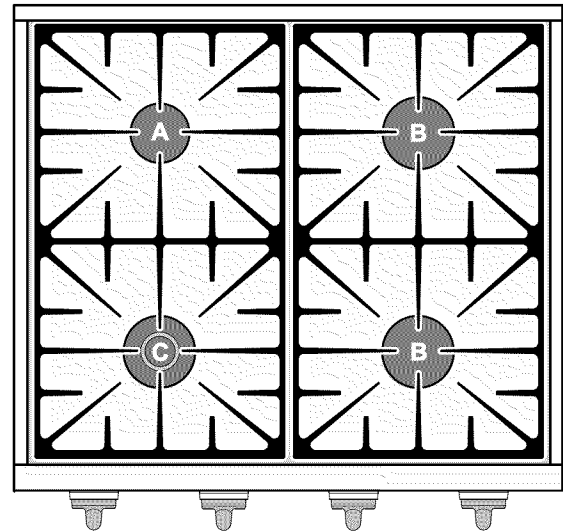

Model DRT304S - 4 burners

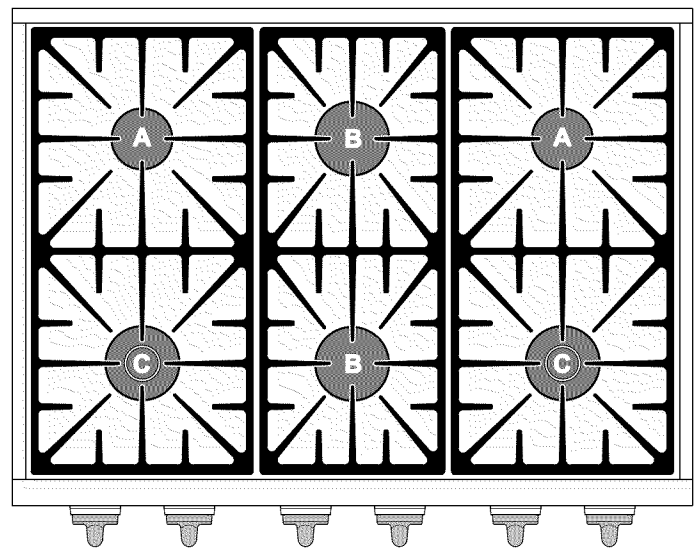

Model DRT366S - 6 burners

# Setting Up Your Cooktop

## Burner and Grate Assembly

### WARNING

Assemble the burners and grates only when the cooktop is cool.

Remove the burner rings, burner caps and grates from their shipping packages.

### SimmerSear Burner Assembly

1. Install the SimmerSear burner ring(s) on top of the SimmerSear burner base(s). Line up the indentations on the bottom of the burner ring with the pins on the top of the burner base.
2. Set the outer SimmerSear burner cap(s) on top of the burner ring(s). Make sure the burner ring is centered on top.
3. Set the inner SimmerSear burner cap(s) on the center of the dual burner base(s). Line up the ridge on the bottom of the cap with the pins on the center of the burner base.

### Standard Burner Assembly

1. Install the standard burner rings on the standard burner bases. Put the hole on the edge of each ring over the igniter. Center the tabs on the bottom of each ring in the hole in the center of each base.
2. Install all the standard burner caps. The ridge on the bottom of each cap must surround the top of each ring.

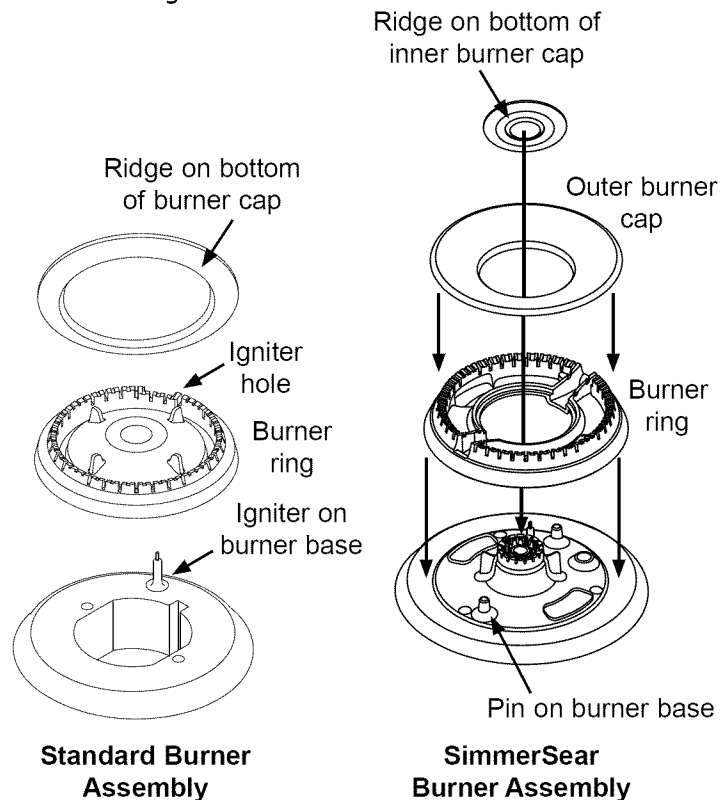

## Grate and Knob Installation

1. Gently set the grates on top of the spill tray. Put the legs of each grate into the corresponding dimples. On model DRT366S, the middle grate is smaller than the other two.

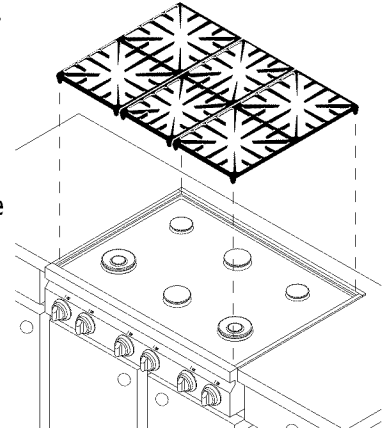

2. Attach the SimmerSear burner knobs **A** as shown below. The SimmerSear knobs have a wider space between the large flame icon and the simmer icon than the standard burner knobs. Align the "D-shaped" opening on the back of each knob with the end of the valve shaft. Carefully push each knob on until it stops.
3. Attach the remaining knobs which operate the standard burners **B**.

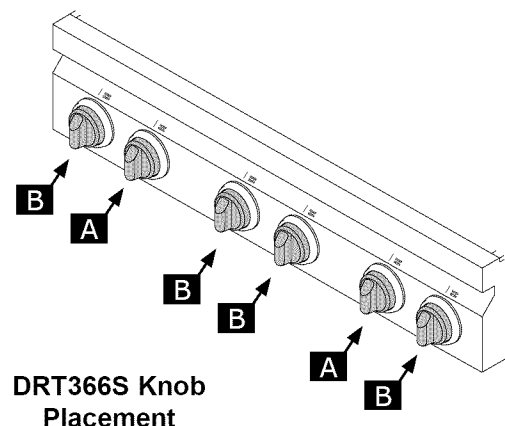
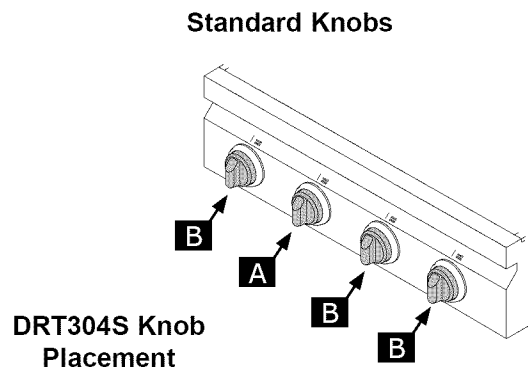

# Operating Your Cooktop

## Selecting the Cookware

### **WARNING**

- To avoid burns and scalding, always turn pan handles to a position where they cannot be easily hit. Also, handles should not extend over adjacent burners. Always set utensils gently onto the grates and center them so that they are well-balanced.
- Do not drag cookware across the grates. Sliding may damage the finish. Lift utensils to reposition them. Do not drop them on the grate.
- Cookware with rough bottoms can cause permanent damage to the coated surfaces on the grates.
- To avoid burns or a fire hazard, reduce the flame level if it extends beyond the bottom of the utensil. Flames extending up the sides are potentially dangerous.

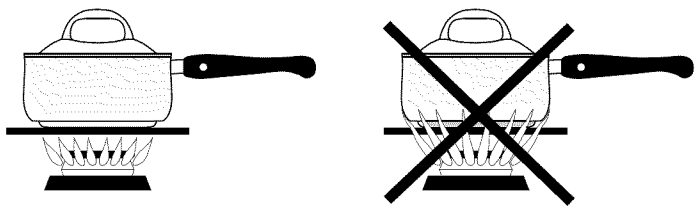

For overall safety and best cooktop performance, select the correct cooking utensil for the food being cooked. Improperly selected cooking utensils will not cook evenly or efficiently.

### Use cookware that:

- Has flat, smooth bottoms.
- Is well balanced.
- Has tight fitting lids to keep heat, odors and steam in.

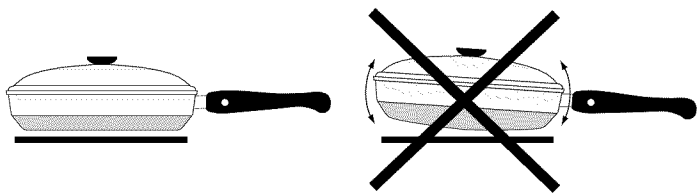

**IMPORTANT:** Avoid spills as much as possible. The porcelain surfaces of the grates, spill trays and burner caps are acid-resistant but not acid-proof. Some foods can cause permanent damage if allowed to remain on porcelain surfaces.

## Lighting a Burner

### **WARNING**

- To avoid the chance of fire, explosion or carbon monoxide poisoning, do not attempt to use your cooktop without the burners completely and properly assembled (see page 5). The burner rings spread the flame evenly around the burner cap. The burner rings must be properly seated for proper burner lighting and operation.
- In the interest of safety, always light the burner before putting the cooking utensil on the grate. Turn the burner knob to the **OFF** position before removing the utensil. Always check the position of the control knobs to make sure the cooktop is off when you are finished cooking.
- Do not turn the knob farther than the **HIGH** position until lit. Doing so may result in a burst of flame that could cause burns or damage to the surrounding area.
- Do not touch any part of the burner while the igniter is sparking. An electrical shock could result.
- Never light the burners with a match or other open flame.
- Always check to make sure all control knobs are in the **OFF** position when you are finished cooking.
- If the gas does not ignite after four seconds or if the flame goes out and gas escapes when attempting to light a burner, turn the knob to the **OFF** position. Open a window and allow at least five minutes for the gas to dissipate. Then, repeat the lighting procedure.

Each burner control knob has a small diagram next to it with an indicator light that tells you which burner it operates.

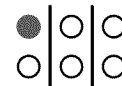

1. To light a burner, push in gently on the knob and turn it counter-clockwise to the **HIGH** position. The igniter will spark (click) repeatedly until the gas ignites. The burner should light within four seconds.

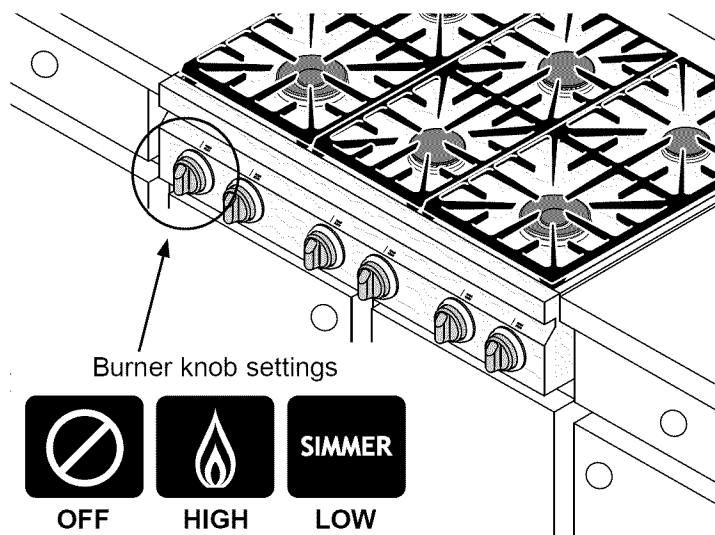



# Operating Your Cooktop

2. Once the burner is lit, set the flame height to the desired level by rotating the control knob further counterclockwise, then place the utensil on the grate.

## **IMPORTANT:**

- The flame should burn evenly around the perimeter of the burner, except underneath each grate support finger, where the flame height is reduced by Dacor's Smart-Flame feature. A normal flame is steady and blue in color. Foreign material in the gas line, especially in new construction, may cause an orange flame during initial operation. The orange color will disappear with further use. Small yellow tips on the ends of the flames are normal when using LP gas.
- If the flame is not even around the edge of the burner, wait for the cooktop to cool and check to make sure the burner is assembled properly (see page 5).
- When the cooktop is cool the igniter may continue to spark if the control knob is set to the **LOW** position. The burner will stop sparking when warm. The tendency to spark when cold can be reduced by operating the burner at a higher flame setting for about 60 seconds. After 60 seconds, lower the flame to cook. The burner will also warm up faster if a utensil is placed on the grate. The igniter will also spark automatically if the flame is distorted by a draft or by the household ventilation system. Eliminate any drafts or reduce the ventilation blower speed to reduce this type of problem.
- To keep the burners operating properly, keep the burner igniters, burner rings and burner caps clean and dry. See **Care and Cleaning** starting on page 8. Dirty or wet igniters will result in constant sparking, even if there is a flame present.

## Cooking Tips

For superior cooking performance and to save energy:

- Reduce the flame height to the minimum level necessary to perform the desired cooking process. Food cooks just as quickly at a gentle boil as it does at a vigorous, rolling boil. A higher boil than is necessary wastes energy, cooks away moisture and causes a loss in food flavor and nutrients.
- Dacor's SimmerSear feature allows you precision control of the flame. The larger the burner size, the wider the range of control. See page 4 for the heat ranges of the different burners.
- Use low or medium flame heights when cooking in utensils made of materials that are poor conductors of heat, such as glass, ceramic and cast iron. Reduce the flame height until it covers approximately 1/3 of the utensil diameter to ensure even heating and reduce scorching.
- Minimize the amount of liquid or fat to reduce cooking times.
- Use a timer rather than repeatedly removing the lid to check food. Doing so will decrease cooking time and save energy.
- Thaw foods prior to cooking to reduce cooking time.

# Care and Cleaning

## ⚠ WARNING

- Clean only the parts of the cooktop listed in this manual. Clean them only in the manner specified.
- To avoid dangerous fumes or damage to your cooktop's surfaces and accessories, use only the types of cleaning solutions specified in this manual.
- To avoid electrical shock or burns, turn off the burners and make sure that all parts are cool before cleaning. **DO NOT** turn the burners on during cleaning.
- Do not use a steam cleaner to clean the cooktop. Steam could penetrate the electrical components and cause a short circuit. After cleaning the burners, reassemble all of the burner parts before attempting to operate the cooktop.
- After cleaning the burners, always dry and reassemble the cooktop parts completely before use. See page 5.

## ⚠ CAUTION

- Do not try to remove heavy spills with a sharp object such as a knife or metal spatula. Sharp objects may scratch your cooktop's surfaces.
- To prevent damage, do not use abrasive or corrosive cleaners or applicators such as steel wool or scouring pads, on any part of the cooktop unless instructed to do so. Use only a sponge, soft cloth, fibrous or plastic brush or nylon cleaning pad for cleaning the surfaces of your cooktop.
- Do not remove the trim rings from the cooktop. Clean only the outside edges of the trim rings. If you get moisture inside the trim rings damage to the cooktop may occur.
- Do not soak the knobs in water or put them in the dishwasher.
- Installing the cooktop knobs in the wrong position may result in damage to the optional cooktop griddle or grill. Two of the knobs that come with the griddle/grill kit are marked with the maximum griddle settings. See the griddle or grill instructions.

## Cleaning the Cooktop

To keep the cooktop looking and operating its best, clean it after every use. Also, quickly wipe up spills that occur while cooking. Be careful not to touch any hot areas. Spills that remain on hot burner parts will be very difficult to clean, especially if allowed to burn on. Certain types of food, such as tomatoes, citrus juices, vinegar, alcohol and milk can damage the finishes if you allow them to stand for any length of time.

**IMPORTANT:** The cooktop is exposed to extremely high temperatures. The grates are under high stress when hot utensils are placed on them. Also, the cooktop parts are occasionally exposed to acidic food spill-overs. These severe operating conditions, cause the porcelain enamel parts on your cooktop to undergo a change in appearance over time. If you care for and clean these parts carefully, you will slow down, but not eliminate, the aging process.

### Cooktop Disassembly

1. For safety, disconnect the cooktop power cord from the electrical outlet prior to cleaning.
2. When the appliance is cool, remove the grates from the top of the cooktop.
3. Disassemble the burners. Lift the burner caps and burner rings off of the burners.

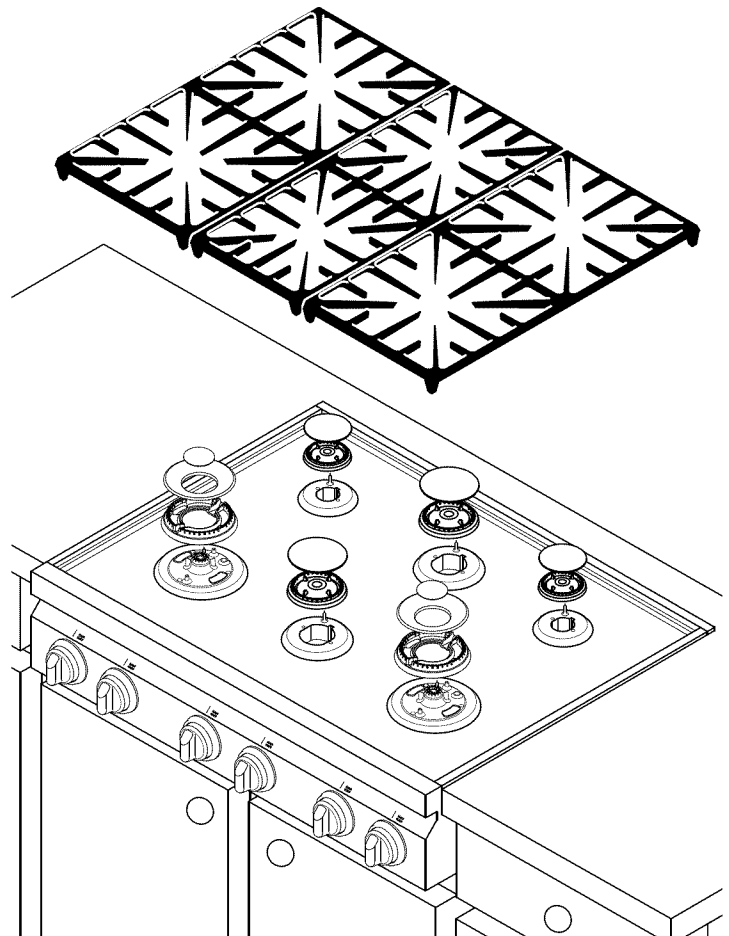

# Care and Cleaning

## Burner Components and Igniters

### ⚠ CAUTION

Use care while cleaning the igniters. The porcelain is fragile and can crack or break.

**IMPORTANT:** The igniters may not spark or work properly if the burner parts or the igniters themselves are not clean and dry.

After disassembling the burners, check for any dirt or grime deposited on the individual parts, including the igniters.

1. Use a firm toothbrush to clean completely around the igniter, including all of the metal top and porcelain base. Use care while cleaning because the porcelain is fragile and can crack or break. Do not use water to clean the igniters. If necessary, use a small amount of rubbing alcohol to help dissolve grime.
2. Examine the burner rings. Remove anything stuck in the holes with a straightened paper clip, wire or needle. Be careful not to scratch or damage the ring and head. Do not distort the shape of the burner ring holes.
3. Clean all of the burner parts, including the burner bases, with window cleaner or rubbing alcohol. Use a cleaning brush with plastic bristles or a firm tooth brush. When done, rinse the parts well with clean water. Dry all the parts thoroughly before re-assembling them.
4. Reassemble the cooktop according to the burner and grate assembly instructions on page 5. Test the burners after reassembling them. If the flame is uneven, be sure that all the burner parts are properly positioned, then check for any remaining dirt or grime on the burner parts or igniter. If erratic sparking (clicking) is still present, make sure the igniter is completely dry. If the unit still exhibits problems after drying, call your local Dacor Authorized Service Agent.

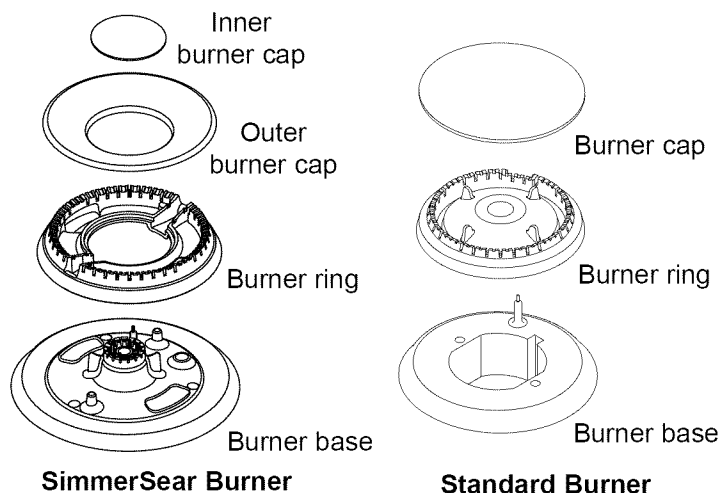

## Grates, Spill Trays and WOK Ring

### ⚠ CAUTION

Do not clean the cooktop grates, burner parts or WOK ring in a dishwasher. They will be damaged.

The grates, the spill tray and optional WOK ring are coated with a porcelain finish.

- For everyday cleaning, use a soft cloth or non-abrasive pad with warm soapy water to clean all of the porcelain parts.
- If necessary, tough stains may be removed by applying full-strength sprays such as Simple Green™, Ajax™ All-Purpose Cleaner or Formula 409™. To minimize wear, use the mildest cleaner needed to get the surface clean.
- For extremely stubborn stains, you may use a mildly abrasive cleaner or applicator, such as Soft Scrub™, Bon Ami™, S.O.S.® pads or other soap-filled steel wool pads. Use these cleaners with extreme care and only on occasion. Extensive use of these types of abrasives will eventually damage the porcelain enamel.

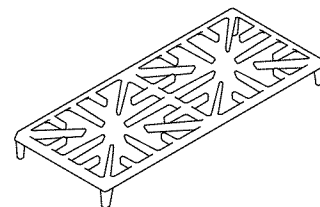

## Stainless Steel Surfaces

### ⚠ CAUTION

Always wipe stainless steel (silver colored) surfaces with the grain. To prevent scratching, do not use abrasive cleaners or scrubbers on stainless steel surfaces.

- Use the included Dacor Stainless Steel Cleaner on the stainless steel surfaces. Use it according to the directions on the package. See page 10 for reorder information.
- You may also clean stainless steel surfaces with a mild solution of detergent and warm water. Rinse and dry with a soft, lint-free cloth.

## Brass, Chrome and Copper Surfaces

### ⚠ CAUTION

To prevent scratching, do not use abrasive cleaners or scrubbers on metal surfaces.

Using a soft cloth, clean metal surfaces with a mild solution of detergent and warm water. Rinse and dry with a soft, lint-free cloth.

**Continued...**

# Care and Cleaning

## Cleaning the Cooktop (continued)

### Knobs and Trim Rings

#### **WARNING**

Never block the holes in the control panel behind the knobs. Doing so will impair the flow of combustion air and adversely affect burner operation, possibly creating a hazardous condition.

To prevent damage, do not expose the knobs to direct flame, hot utensils or other sources of heat.

- Turn the knobs to the off position before removing them for cleaning or replacement.
- To remove the knobs, gently grasp each knob and pull straight out, off of the valve shaft.

- Wash the knobs regularly with a solution of warm soapy water. Dacor recommends hand dishwashing liquid.
- Clean the outside edges of the trim rings while the knobs are removed. Do not remove the trim rings. Wipe them with a soft damp rag. Use caution to avoid getting moisture into the control panel behind the trim rings.
- Replace the knobs according to the directions on page 5. Be sure to install the knobs in their proper positions.

## Accessories and Replacement Parts

Description	Dacor Part Number
Dacor Stainless Steel Cleaner	A302
Wok ring	AWR4
Griddle for model DRT304S	ADRT14
Grill for model DRT304S	AGDRT14
Griddle for model DRT366S	ADRT12
Grill for model DRT366S	AGDRT12
9 inch backguard, model DRT304S	AEB3009
9 inch backguard, model DRT366S	AEB3609
12 inch backguard, model DRT304S	AEB3012
12 inch backguard, model DRT366S	AEB3612
10" grate (center grate, for model DRT366S only, 1 used per unit)	700037
12" grate (right and left grate, for model DRT366S only, 2 used per unit)	701196
14" grate (for model DRT304S only, 2 used per unit)	101524

To order parts and accessories, contact your Dacor dealer or visit [www.everythingdacor.com](http://www.everythingdacor.com).

# Before You Call for Service

## Problem Solution Guide

Problem	May Be Caused By	What to Do
Nothing works.	Cooktop not connected to electrical power.	Check to make sure power cord is connected to electrical outlet.
	Power to electrical outlet is off.	Turn on power at circuit breaker or fuse box. Check for tripped breaker or blown fuse.
	Power outage.	Contact power company.
Igniters do not spark (no clicking sound).	Power not supplied to unit.	See <b>Nothing Works</b> above.
	Wet or dirty igniter(s).	Clean and dry igniter and burner assembly according to <b>Care and Cleaning</b> section.
No flame.	Igniter(s) not working.	See <b>Igniters do not spark</b> above.
	Wet or dirty igniter(s).	Clean and dry according to <b>Care and Cleaning</b> section.
	Gas is turned off.	Make sure the gas supply valve is in the on position.
	Gas supply interrupted.	Contact gas company.
Burner goes out at low setting.	Air intake holes obstructed.	Check to make sure air holes above knobs are not blocked.
	Low gas pressure.	Contact gas company to have pressure tested.
Flame is distorted, yellow or very large.	Burner parts are dirty or clogged.	Clean and dry according to <b>Care and Cleaning</b> section.
	Burner parts are not properly positioned.	Make sure burner is assembled according to the <b>Setting Up Your Cooktop</b> section.
	Cooktop set up to use a different type of gas (Natural or LP) or set up for different altitude.	Have a qualified service technician check to make sure that the cooktop is set up for the type of gas and the correct altitude.
	Gas regulator is not installed or faulty.	Have a qualified service technician check the gas regulator.
Igniter continues to spark (click) after flame ignites.	Burner is cold.	Burners may continue to spark for up to 60 seconds when cold and set to low. See <b>Operating Your Cooktop</b> section for more information on how to minimize.
	Flame distorted by air draft.	Minimize any air drafts around the cooktop. Close nearby windows.
	Wet or dirty igniter(s).	Clean and dry according to <b>Care and Cleaning</b> section.
	Burner parts wet or dirty.	Clean and dry according to <b>Care and Cleaning</b> section.
	Burner parts not properly positioned.	Make sure burner is assembled according to the <b>Setting Up Your Cooktop</b> section.
	Power supply polarity is reversed.	Have a licensed electrician check the electrical outlet.

# Warranty and Service

## Getting Help

Before you request service, please review the **Before You Call for Service** section on page 11. If you have performed the checks in the **Problem Solution Guide** and the problem has not been remedied, please contact us at one of the numbers below. Prior to requesting service, it is helpful to be familiar with the warranty terms and conditions listed in the **Warranty** section below.

**For warranty repairs, call:**

**Dacor Distinctive Service:**

Phone: (877) 337-3226 (U.S.A. and Canada)  
Business Hours: 6:00 A.M. - 4:00 P.M. Pacific Time

**For non-warranty repairs, call:**

**Dacor Customer Service:**

Phone: (800) 793-0093 (U.S.A. and Canada)  
Business Hours: 6:00 A.M. - 5:00 P.M. Pacific Time

**Contact us through our web site at:**

www.Dacor.com

*At Dacor, we believe that our quality of service equals that of our product. Should your experience with our service network or product be different, please contact our Customer Service Team and share your encounter with us. We will do our utmost to resolve the situation for you and deliver on our Dacor promise.*

*If you need anything clarified, just let us know.*

## Warranty

### What is Covered

#### **CERTIFICATE OF WARRANTIES: DACOR COOKTOPS**

**WITHIN THE FIFTY STATES OF THE U.S.A., THE DISTRICT OF COLUMBIA AND CANADA\*:**

#### **FULL ONE-YEAR WARRANTY**

If your DACOR product fails to function within one year of the original date of purchase, due to a defect in material or workmanship, DACOR will remedy the defect without charge to you or subsequent users. The owner must provide proof of purchase upon request, and have the appliance accessible for service.

\*Warranty is null and void if non-ETL approved product is transported from the U.S.

#### **OUTSIDE THE FIFTY STATES OF THE U.S.A., THE DISTRICT OF COLUMBIA AND CANADA:**

#### **LIMITED FIRST YEAR WARRANTY**

If your DACOR product fails to function within one year of the original date of purchase, due to a defect in material or workmanship, DACOR will furnish a new part, F.O.B. factory to replace the defective part. All delivery, installation and labor costs are the responsibility of the purchaser. The owner must provide proof of purchase, upon request, and have the appliance accessible for service.

### What Is Not Covered

- Service calls to educate the customer in the proper use and care of the product.
- Failure of the product when used for commercial, business, rental or any application other than for residential consumer use.
- Replacement of house fuses or fuse boxes or resetting of circuit breakers.
- Damage to the product caused by accident, fire, flood or other acts of God.
- Breakage, discoloration or damage to glass, metal surfaces, plastic components, trim, paint or other cosmetic finish, caused by improper usage or care, abuse or neglect.

THE REMEDIES PROVIDED FOR IN THE ABOVE EXPRESS WARRANTIES ARE THE SOLE AND EXCLUSIVE REMEDIES. THEREFORE, NO OTHER EXPRESS WARRANTIES ARE MADE, AND OUTSIDE THE FIFTY STATES OF THE UNITED STATES, THE DISTRICT OF COLUMBIA AND CANADA, ALL IMPLIED WARRANTIES, INCLUDING BUT NOT LIMITED TO, ANY IMPLIED WARRANTY OF MERCHANTABILITY OR FITNESS FOR A PARTICULAR USE OR PURPOSE, ARE LIMITED IN DURATION TO ONE YEAR FROM THE DATE OF ORIGINAL PURCHASE. IN NO EVENT SHALL DACOR BE LIABLE FOR INCIDENTAL EXPENSE OR CONSEQUENTIAL DAMAGES. NO WARRANTIES, EXPRESS OR IMPLIED, ARE MADE TO ANY BUYER FOR RESALE.

Some states do not allow limitations on how long an implied warranty lasts, or do not allow the exclusion or limitation of inconsequential damages, so the above limitations or exclusions may not apply to you. This warranty gives you specific legal rights, and you may also have other rights that vary from state to state.

fold here



NO POSTAGE  
NECESSARY  
IF MAILED  
IN THE  
UNITED STATES

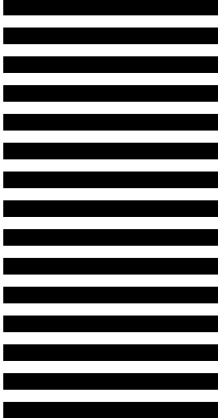

**BUSINESS REPLY MAIL**  
FIRST-CLASS MAIL PERMIT NO 1600 CITY OF INDUSTRY CA

POSTAGE WILL BE PAID BY ADDRESSEE

**DACOR  
ATTN WARRANTY PROCESSING DEPT  
PO BOX 90070  
CITY OF INDUSTRY CA 91715-9907**





Please visit [www.Dacor.com](http://www.Dacor.com) to activate your warranty online.

# WARRANTY INFORMATION



### IMPORTANT:

Your warranty will not be activated until you activate it online or return this form to Dacor. If you have purchased more than one Dacor product, please return all forms in one envelope or activate the warranty for each product online.

Please rest assured that under no conditions will Dacor sell your name or any of the information on this form for mailing list purposes. We are very grateful that you have chosen Dacor products for your home and do not consider the sale of such information to be a proper way of expressing our gratitude!

Owner's Name: \_\_\_\_\_  
Last (Please Print or Type) First Middle

Street: \_\_\_\_\_

City: \_\_\_\_\_ State: \_\_\_\_\_ Zip: \_\_\_\_\_

Purchase Date: \_\_\_\_\_ Email: \_\_\_\_\_ Telephone: \_\_\_\_\_

Dealer: \_\_\_\_\_

City: \_\_\_\_\_ State: \_\_\_\_\_ Zip: \_\_\_\_\_

Your willingness to take a few seconds to fill in the section below will be sincerely appreciated. Thank you.

1. How were you **first** exposed to Dacor products? (Please check one only.)

- A. T.V. Cooking Show
- B. Magazine
- C. Appliance Dealer Showroom
- D. Kitchen Dealer Showroom
- E. Home Show
- F. Builder
- G. Architect/Designer
- H. Another Dacor Owner
- I. Model Home
- J. Other \_\_\_\_\_

2. Where did you buy your Dacor appliances?

- A. Appliance Dealer
- B. Kitchen Dealer
- C. Builder Supplier
- D. Builder
- E. Other \_\_\_\_\_

3. For what purpose was the product purchased?

- A. Replacement **only**
- B. Part of a Remodel
- C. New Home
- D. Other \_\_\_\_\_

4. What is your household income?

- A. Under \$75,000
- B. \$75,000 – \$100,000
- C. \$100,000 – \$150,000
- D. \$150,000 – \$200,000
- E. \$200,000 – \$250,000
- F. Over \$250,000

5. What other brands of appliances do you have in your kitchen?

- A. Cooktop \_\_\_\_\_
- B. Oven \_\_\_\_\_
- C. Dishwasher \_\_\_\_\_
- D. Refrigerator \_\_\_\_\_

6. Would you buy or recommend another Dacor product?

- Yes
- No

Comments: \_\_\_\_\_

Thank you very much for your assistance. The information you have provided will be extremely valuable in helping us plan for the future and giving you the support you deserve.

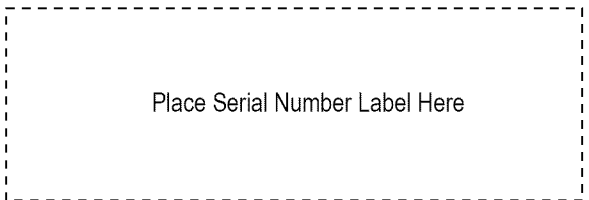

cut here