

**Sears**

*owners  
manual*

**MODEL NO.  
113.22560**

Serial  
Number \_\_\_\_\_

Model and serial  
number may be found  
on the right side  
of the base.

You should record both  
model and serial number  
in a safe place for  
future use.

**CAUTION:**

Read **GENERAL**  
and **ADDITIONAL**  
**SAFETY**  
**INSTRUCTIONS**  
carefully

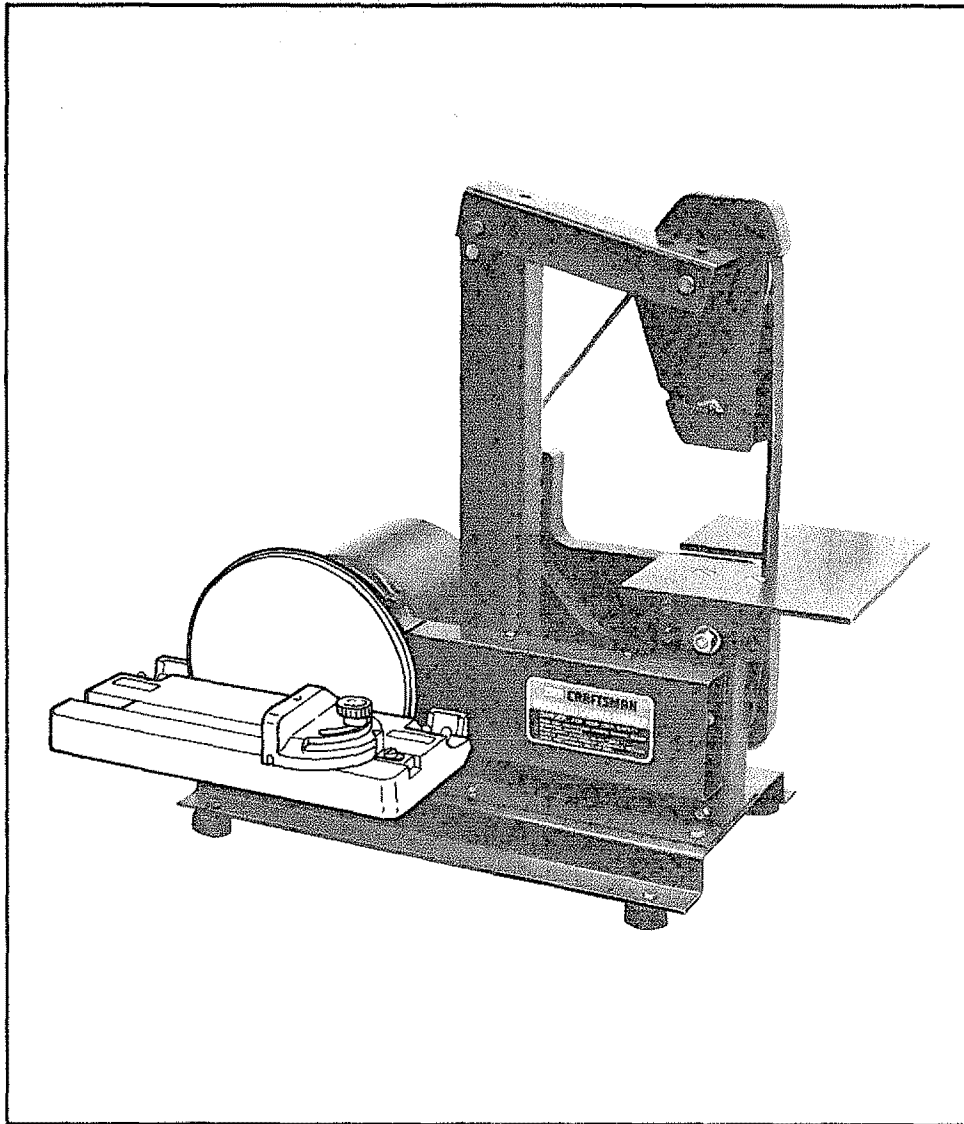

**Sears CRAFTSMAN.**

**1 INCH  
SANDER GRINDER**

- *assembly*
- *operating*
- *repair parts*

Sold by SEARS, ROEBUCK AND CO., Chicago, IL. 60684 U.S.A.

## FULL ONE YEAR WARRANTY ON CRAFTSMAN 1 INCH SANDER/GRINDER

If within one year from the date of purchase, this Craftsman 1 inch Sander/Grinder fails due to a defect in material or workmanship, Sears will repair it, free of charge.

WARRANTY SERVICE IS AVAILABLE BY SIMPLY CONTACTING THE NEAREST SEARS STORE OR SERVICE CENTER THROUGHOUT THE UNITED STATES.

This warranty gives you specific legal rights, and you may also have other rights which vary from state to state.

SEARS, ROEBUCK AND CO., Sears Tower, BSC 41-3, Chicago, IL 60684

## general safety instructions for power tools

- 1. KNOW YOUR POWER TOOL**  
Read the owner's manual carefully. Learn its application and limitations as well as the specific potential hazards peculiar to this tool.
- 2. GROUND ALL TOOLS**  
This tool is equipped with an approved 3-conductor cord and a 3-prong grounding type plug to fit the proper grounding type receptacle. The green conductor in the cord is the grounding wire. Never connect the green wire to a live terminal.
- 3. KEEP GUARDS IN PLACE**  
in working order, and in proper adjustment and alignment.
- 4. REMOVE ADJUSTING KEYS AND WRENCHES**  
Form habit of checking to see that keys and adjusting wrenches are removed from tool before turning it on.
- 5. KEEP WORK AREA CLEAN**  
Cluttered areas and benches invite accidents. Floor must not be slippery due to wax or sawdust.
- 6. AVOID DANGEROUS ENVIRONMENT**  
Don't use power tools in damp or wet locations or expose them to rain. Keep work area well lighted. Provide adequate surrounding work space.
- 7. KEEP CHILDREN AWAY**  
All visitors should be kept a safe distance from work area.
- 8. MAKE WORKSHOP KID-PROOF**  
— with padlocks, master switches, or by removing starter keys.
- 9. DON'T FORCE TOOL**  
It will do the job better and safer at the rate for which it was designed.
- 10. USE RIGHT TOOL**  
Don't force tool or attachment to do a job it was not designed for.
- 11. WEAR PROPER APPAREL**  
Do not wear loose clothing, gloves, neckties or jewelry (rings, wrist watches) to get caught in moving parts. Nonslip footwear is recommended. Wear protective hair covering to contain long hair. Roll long sleeves above the elbow.
- 12. USE SAFETY GOGGLES (Head Protection)**  
Wear Safety goggles (must comply with ANS Z87.1) at all times. "Everyday eyeglasses only have impact resistant lenses, they are NOT safety glasses." Also, use face or dust mask if cutting operation is dusty, and ear protectors (plugs or muffs) during extended periods of operation.
- 13. SECURE WORK**  
Use clamps or a vise to hold work when practical. It's safer than using your hand, frees both hands to operate tool.
- 14. DON'T OVERREACH**  
Keep proper footing and balance at all times.
- 15. MAINTAIN TOOLS WITH CARE**  
Keep tools sharp and clean for best and safest performance. Follow instructions for lubricating and changing accessories.
- 16. DISCONNECT TOOLS**  
before servicing; when changing accessories such as blades, bits, cutters, etc.
- 17. AVOID ACCIDENTAL STARTING**  
Make sure switch is in "OFF" position before plugging in.
- 18. USE RECOMMENDED ACCESSORIES**  
Consult the owner's manual for recommended accessories. Follow the instructions that accompany the accessories. The use of improper accessories may cause hazards.
- 19. NEVER STAND ON TOOL**  
Serious injury could occur if the tool is tipped or if the cutting tool is accidentally contacted.  
Do not store materials above or near the tool such that it is necessary to stand on the tool to reach them.
- 20. CHECK DAMAGED PARTS**  
Before further use of the tool, a guard or other part that is damaged should be carefully checked to ensure that it will operate properly and perform its intended function. Check for alignment of moving parts, binding of moving parts, breakage of parts, mounting, and any other conditions that may affect its operation. A guard or other part that is damaged should be properly repaired or replaced.
- 21. DIRECTION OF FEED**  
Feed work into a blade or cutter against the direction of rotation of the blade or cutter only.
- 22. NEVER LEAVE TOOL RUNNING UNATTENDED**  
Turn power off. Don't leave tool until it comes to a complete stop.

# ADDITIONAL SAFETY INSTRUCTIONS FOR SANDER/GRINDER

**WARNING: FOR YOUR OWN SAFETY, DO NOT ATTEMPT TO OPERATE YOUR SANDER/GRINDER UNTIL IT IS COMPLETELY ASSEMBLED ACCORDING TO THE INSTRUCTIONS, AND THAT YOU UNDERSTAND THE FOLLOWING (SEE CONTENTS... PAGE 3.)**

1. General safety Instructions for Power Tools (Page 2)
2. Getting to Know Your Sander/Grinder (Page 5)
3. Basic Sander/Grinder Operations (Page 6)
4. Maintenance (Page 8)
5. **Power Source Outlet.** This tool should be grounded while in use to protect the operator from electric shock. See "Motor Specifications and Electrical Requirements" section further on in this manual.
6. **Support Workpiece.** Maintain control of workpiece at all times.
7. **Do Not Wet Grind or Polish.** Never use a steady stream of water on the workpiece. Only quench the workpiece in water to cool it.

8. **Do Not Grind or Polish Magnesium . . .** because it could catch on fire.
9. **Note and follow Safety Instructions that appear on the belt guard.**

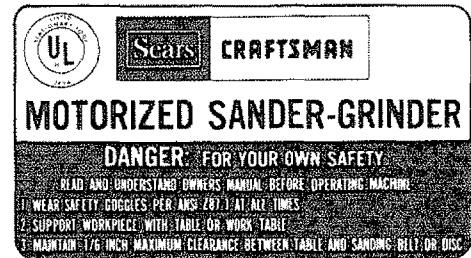

10. **THINK SAFETY:** Safety is a combination of operator common sense and alertness at all times when the Sander/Grinder is being used.

**WARNING: DO NOT ALLOW FAMILIARITY (GAINED FROM FREQUENT USE OF YOUR SANDER/GRINDER) TO BECOME COMMONPLACE. ALWAYS REMEMBER THAT A CARELESS FRACTION OF A SECOND IS SUFFICIENT TO INFLICT SEVERE INJURY.**



The operation of any power tool can result in foreign objects being thrown into the eyes, which can result in severe eye damage. Always wear safety goggles complying with ANSI Z87.1 (shown on Package) before commencing power tool operation. Safety Goggles are available at Sears retail or catalog stores.

## CONTENTS

|   | Page |
|---|------|
| General Rules for Power Tools . . . . .                     | 2    |
| Additional Safety Instructions for Sander Grinder . . . . . | 3    |
| Motor Specifications and Electrical Requirements . . . . .  | 4    |
| Assembly . . . . .  | 5    |
| Installing Abrasive Belt . . . . .                          | 5    |
| Tracking Abrasive Belt . . . . .                            | 5    |
| Getting to Know Your Sander/Grinder . . . . .               | 6    |
| Basic Sander/Grinder Operation . . . . .                    | 6    |
| Sanding Wood or Plastics . . . . .                          | 6    |
| Grinding Metal . . . . .                                    | 7    |
| Inside Work . . . . .                                       | 7    |
| Sharpening . . . . .  | 8    |
| Polishing . . . . .   | 8    |
| Maintenance . . . . .                                       | 8    |
| Lubrication . . . . .                                       | 8    |
| Recommended Accessories . . . . .                           | 9    |
| Trouble Shooting . . . . .                                  | 9    |
| Repair Parts . . . . .                                      | 10   |

## TOOLS NEEDED



9/16 INCH WRENCH

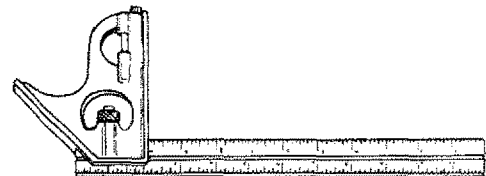

COMBINATION SQUARE

# MOTOR SPECIFICATIONS AND ELECTRICAL REQUIREMENTS

## MOTOR SPECIFICATIONS

The AC motor is a Split Phase non-reversible type, with the following specifications:

|  |           |
|--|-----------|
| Horsepower .....                                 | 1/3       |
| Voltage .....                                    | 115       |
| Amperes .....                                    | .6        |
| Hertz .....                                      | .60       |
| Phase .....                                      | Single    |
| RPM .....  | 1725      |
| Rotation (viewed from Pulley end) .....          | clockwise |
| Abrasive Belt Speed (Feet Per Min.) Approx. .... | .3000     |

Although the motor is designed for operation on the voltage and frequency specified on motor nameplate, normal loads will be handled safely on voltages not more than 10% above or below the nameplate voltage. Heavy loads, however, require that voltage at motor terminals be not less than the voltage specified on nameplate.

## CONNECTING TO POWER SOURCE OUTLET

This Sander/Grinder must be grounded while in use to protect the operator from electrical shock.

If power cord is worn or cut, or damaged in any way, have it replaced immediately.

If your Sander/Grinder is for use on less than 150 volts it has a plug that looks like below.

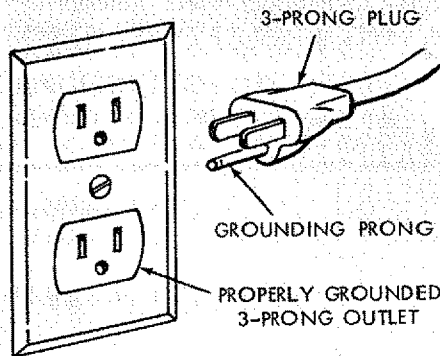

Plug power cord into 110-120V properly grounded type outlet protected by a 15-amp. time delay or Circuit-Saver fuse or circuit breaker.

**IF YOU ARE NOT SURE THAT YOUR OUTLET IS PROPERLY GROUNDED, HAVE IT CHECKED BY A QUALIFIED ELECTRICIAN.**

**WARNING: DO NOT PERMIT FINGERS TO TOUCH THE TERMINALS OF PLUG WHEN INSTALLING OR REMOVING THE PLUG TO OR FROM THE OUTLET.**

**WARNING: IF NOT PROPERLY GROUNDED THIS POWER TOOL CAN INCUR THE POTENTIAL HAZARD OF ELECTRICAL SHOCK, PARTICULARLY WHEN USED IN DAMP LOCATIONS, IN PROXIMITY TO PLUMBING, OR OUT OF DOORS. IF AN ELECTRICAL SHOCK OCCURS THERE IS THE POTENTIAL OF A SECONDARY HAZARD SUCH AS YOUR HANDS CONTACTING THE ABRASIVE BELT OR DISC.**

This Sander/Grinder is equipped with a 3-conductor cord and grounding type plug which has a grounding prong, approved by Underwriters' Laboratories and the Canadian Standards Association. The ground conductor has a green lug and is attached to the tool housing at one end and to the ground prong in the attachment plug at the other end.

This plug requires a mating 3-conductor grounded type outlet as shown.

If the outlet you are planning to use for this Sander/Grinder is of the two prong type DO NOT REMOVE OR ALTER THE GROUNDING PRONG IN ANY MANNER. Use an adapter as shown and always connect the grounding lug to a known ground.

It is recommended that you have a qualified electrician replace the TWO prong outlet with a properly grounded THREE prong outlet.

An adapter as shown below is available for connecting plugs to 2-prong receptacles. The green grounding lug extending from the adapter must be connected to a permanent ground such as to a properly grounded outlet box.

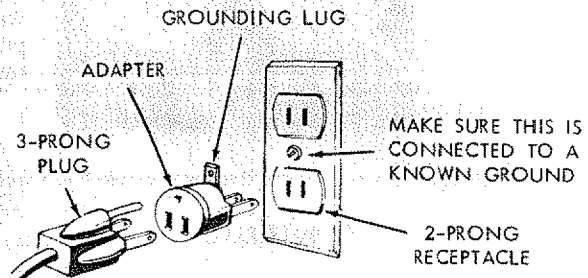

**NOTE:** The adapter illustrated is for use only if you already have a properly grounded 2-prong receptacle. Adapter is not allowed in Canada by the Canadian Electrical Code.

The use of any extension cord will cause some loss of power. To keep this to a minimum and to prevent over-heating and motor burn-out, use the table below to determine the minimum wire size (A.W.G.) extension cord. Use only 3 wire extension cords which have 3 prong grounding type plugs and 3-pole receptacles which will accept the plug on the Sander/Grinder.

| Extension Cord Length | Wire Size A.W.G. |
|-----------------------|------------------|
| Up to 100 Ft. ....    | .16              |
| 100-200 Ft. ....      | .14              |
| 200-400 Ft. ....      | .10              |

# ASSEMBLY

Your Craftsman Sander/Grinder is shipped complete including the motor. The Disc Sanding attachment and Miter Gauge are optional accessories.

**WARNING: FOR YOUR OWN SAFETY, NEVER CONNECT PLUG TO POWER SOURCE OUTLET UNTIL ALL ASSEMBLY STEPS ARE COMPLETED.**

The top arm is spring loaded and held down for shipping purposes with a piece of cord. Hold down against spring pressure on the arm, remove the cord and ease up on the arm.

Apply a coat of automobile wax to the table.  
Wipe all parts thoroughly with a clean, dry cloth.

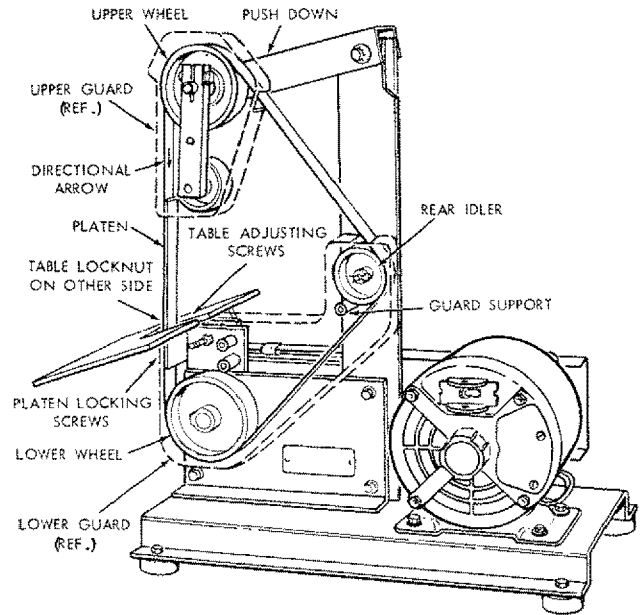

## INSTALLING ABRASIVE BELT

Your Sander/Grinder is shipped with the abrasive belt installed. When replacing belts, notice directional arrow → on inside of belt . . . it must point downward on the front section of the belt when installed.

1. Remove both upper and lower belt guards by removing the three (3) wing screws which secure the guards.
2. Push down on arm and position belt over upper and lower wheels and rear idler.
3. Using a 9/16 inch wrench, loosen TABLE LOCKNUT . . . swing table upwards and move it as close to the belt without touching it.
4. Using an accurate square adjust table 90° to belt . . .

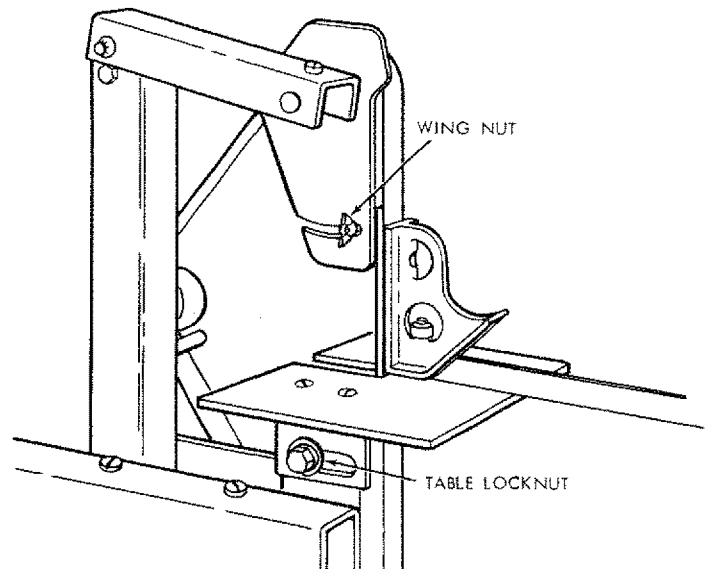

## TRACKING BELT

**CAUTION: Remove both upper and lower guard. Sanding belt may cut into guard prior to final tracking.**

1. Turn motor "ON". Belt should be running in center of upper wheel.
2. If it runs toward the right or left side of the wheel, loosen screw "A" using 3/16" set screw wrench furnished with your Sander/Grinder.
3. Turn screw "B" with Hex wrench and notice belt move sideways. Turn screw right or left until belt is running in center of wheel.
4. Tighten screw "A".
5. If belt touches edges of table, loosen TABLE ADJUSTING SCREWS and reposition table.
6. Belt should be even with edges of platen if it is not, loosen screws holding platen and adjust it.
7. Replace "Upper" and "Lower" Guards.

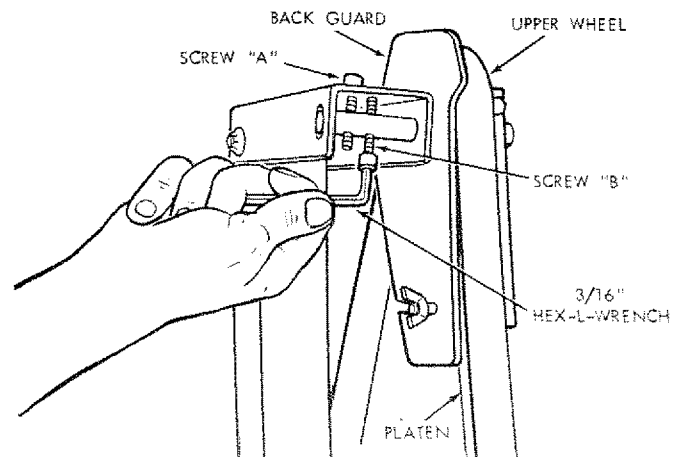

# GETTING TO KNOW YOUR SANDER/GRINDER

TABLE LOCK NUT locks table in place. Use a square or protractor to adjust table to desired angle to belt.

TRACKING SCREWS are adjusted to track belt.

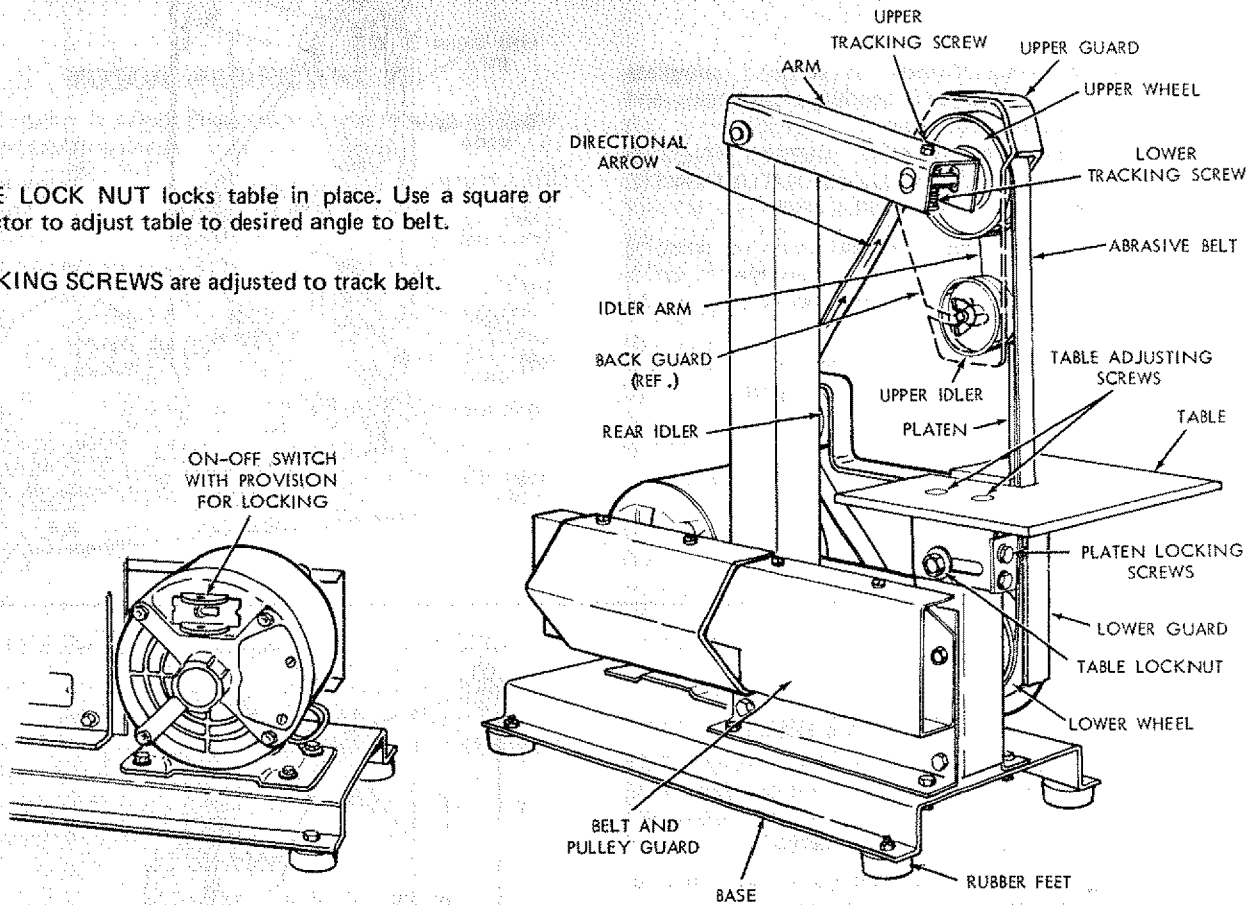

## BASIC SANDER/GRINDER OPERATIONS

We recommend the following instructions for operating your Sander/Grinder so that you get the best results and to minimize personal injury.

**WARNING: FOR YOUR OWN SAFETY, ALWAYS OBSERVE THE FOLLOWING SAFETY PRECAUTIONS.**

1. Make sure Table Lock Nut is always tight.
2. Remove plug from power source outlet when adjusting table, changing belts, or removing or adjusting platen.
3. After turning switch ON, always allow the belt to come up to full speed before sanding or grinding.
4. Make sure belt always tracks properly. Push the workpiece or cutting tool gently against the belt . . . allowing the belt to cut without reducing the belt speed appreciably or stalling the motor.
5. Keep your hands clear of the belt.
6. Replace belts when they become loaded (glazed) or frayed.

### SANDING WOOD OR PLASTICS

Move the workpiece across the belt.

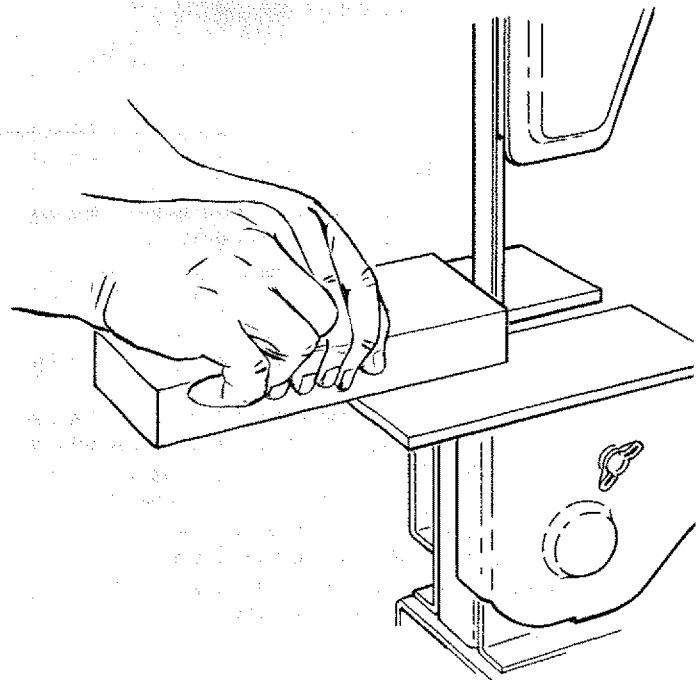

## GRINDING METAL

Move the workpiece across the belt.

If the workpiece becomes too hot to handle, quench it in cold water.

Never push a sharp corner of the workpiece rapidly against the belt because the belt could tear.

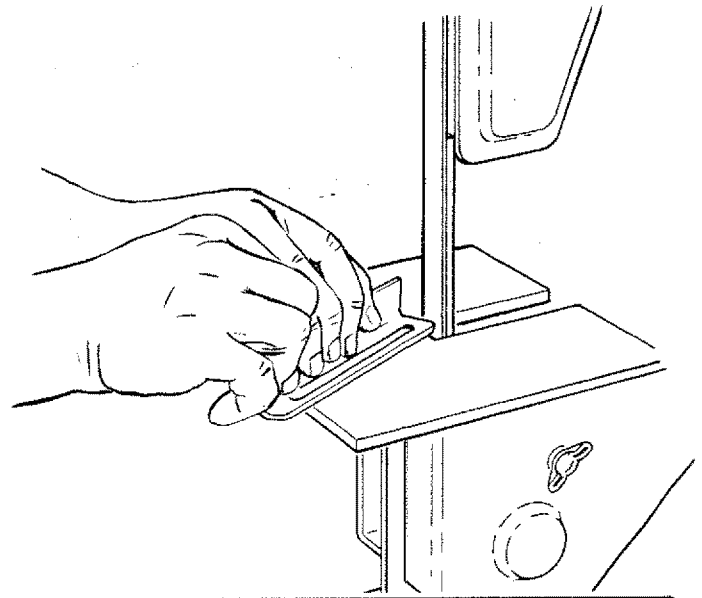

## INSIDE WORK

**WARNING: FOR YOUR OWN SAFETY, REMOVE PLUG FROM POWER SOURCE OUTLET.**

1. Remove both "Upper" and "Lower" guards.
2. Loosen wing nut and position guard back as shown.
3. Remove the "Hairpin Clip" which retains the rear idler. Use a pair of long nose pliers.
4. Remove washer and idler, and position them on shaft underneath table; replace clip.
5. Position belt over lower wheel and under idler. Thread belt through opening in workpiece.

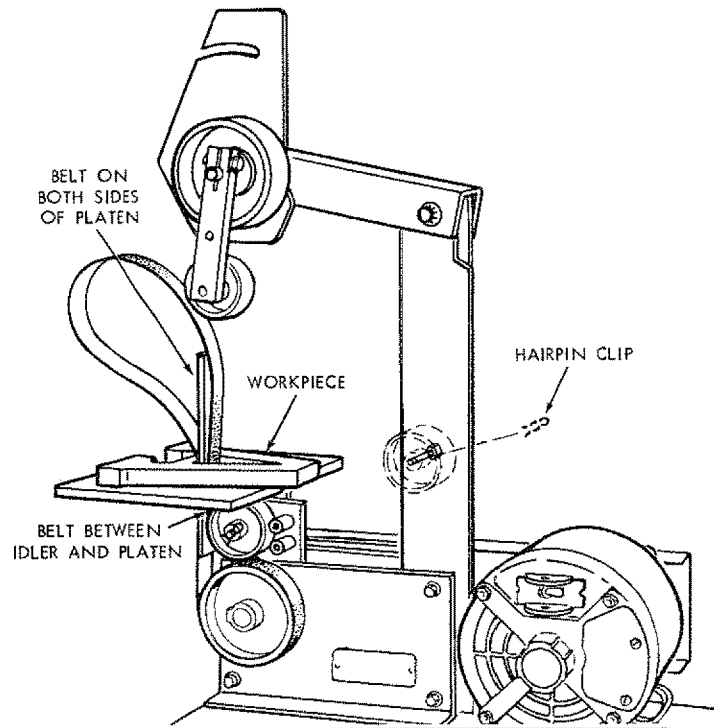

6. Push down on arm and position belt around upper idler and over upper wheel.
7. Make sure upper idler is positioned so that it causes belt to run against platen.
8. It can be adjusted by loosening nut "A" and repositioning idler arm.
9. Replace "Upper" and "Lower" guards.
10. Position guard back and tighten wing nut.
11. Follow same procedure for Sanding or Grinding.

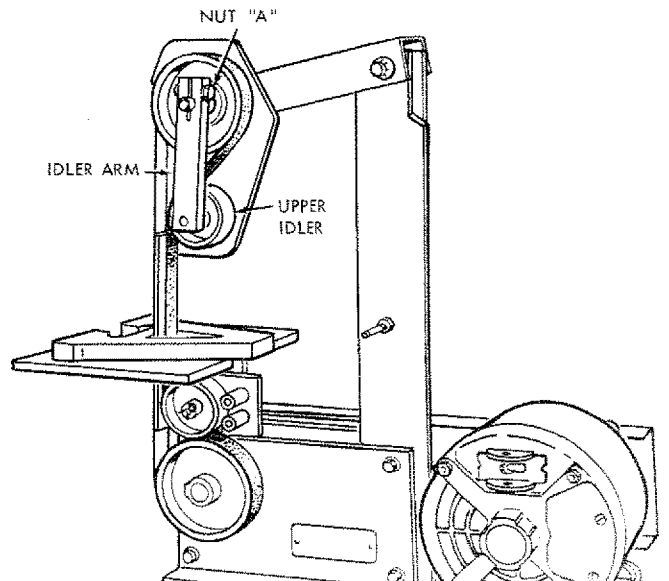

## SHARPENING

1. Adjust table to proper angular position for intended operation. Lock securely.
2. When sharpening short cutting tools such as wood chisels, it will be necessary to clamp a piece of wood to the table.
3. Sand a notch on the back of the wood so that the top corner is close to the belt.
4. Move the cutting tool across the belt, pushing on it gently so that it does not burn.
5. Frequently quench the cutting tool in water to keep it cool.

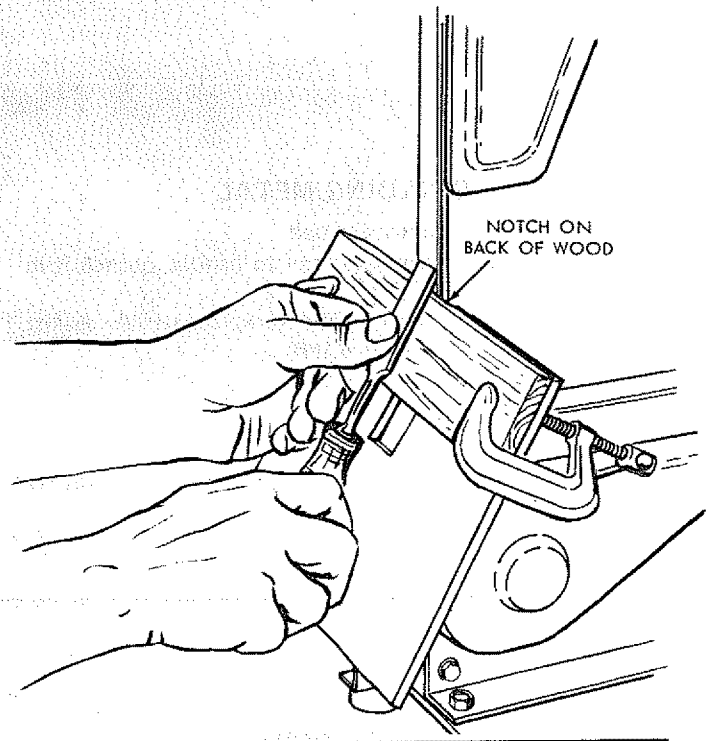

## POLISHING

1. Remove platen and adjust upper idler as shown or swing it to the rear.
2. Push the workpiece against the belt . . . move it gently so that the belt does not come off the wheels.
3. If the workpiece is metal, frequently quench it in water to keep it cool and prevent it from burning.

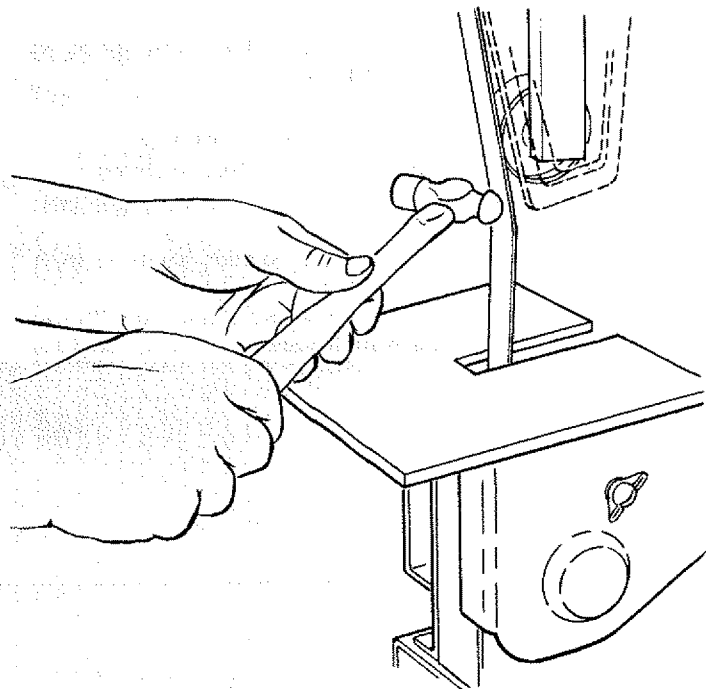

## MAINTENANCE

**WARNING: REMOVE PLUG FROM POWER SOURCE OUTLET BEFORE MAINTAINING OR LUBRICATING YOUR SANDER/GRINDER.**

Keep the Sander/Grinder and motor clean. Frequently blow out dust and chips.

## LUBRICATION

The upper and lower wheels run on ball bearings which are permanently lubricated. They require no further lubrication.

The idlers contain bronze bearings. Occasionally apply a few drops of light machine oil.



# RECOMMENDED ACCESSORIES

DISC SANDING ATTACHMENT ..... 9-22563  
 MITER GAUGE (FOR USE WITH 9-22563) ..... 9-22574  
 ABRASIVE BELTS 1" x 42"  
     FINE ..... 9-26056  
     MEDIUM ..... 9-26055  
     COARSE ..... 9-26054

STEEL STAND ..... 9-22219  
 POWER TOOL KNOW HOW "HANDBOOKS"  
     TABLE SAW ..... 9-2918  
     RADIAL SAW ..... 9-2917

The above recommended accessories are current and were available at the time this manual was printed.

## TROUBLE SHOOTING

**WARNING: FOR YOUR OWN SAFETY, ALWAYS REMOVE PLUG FROM POWER SOURCE OUTLET BEFORE TROUBLE SHOOTING.**

Any attempt to repair the motor may create a hazard unless repair is done by qualified service technician. Repair service is available at your nearest Sears Store.

| TROUBLE  | PROBABLE CAUSE  | SUGGESTED REMEDY  |
|--|---|---|
| Motor will not start.  | <ol style="list-style-type: none"> <li>1. Low voltage.</li> <li>2. Open circuit in motor or loose connections.</li> </ol>   | <ol style="list-style-type: none"> <li>1. Check power line for proper voltage.</li> <li>2. Inspect all lead terminations on motor for loose or open connection.</li> </ol>  |
| Motor will not start, fuses or circuit breakers "blow".  | <ol style="list-style-type: none"> <li>1. Short circuit in line, cord or plug.</li> <li>2. Short circuit in motor or loose connections.</li> <li>3. Incorrect fuses or circuit breakers in powerline.</li> </ol>                      | <ol style="list-style-type: none"> <li>1. Inspect line, cord or plug for damaged insulation and shorted wires.</li> <li>2. Inspect all lead terminations on motor for loose or shorted terminals or worn insulation on wires.</li> <li>3. Install correct fuses or circuit breakers.</li> </ol> |
| Motor fails to develop full power (power output of motor decreases rapidly with decrease in voltage at motor terminals). | <ol style="list-style-type: none"> <li>1. Power line overloaded with lights, appliances and other motors.</li> <li>2. Undersize wires or circuits too long.</li> <li>3. General overloading of power company's facilities.</li> </ol> | <ol style="list-style-type: none"> <li>1. Reduce the load on the power line.</li> <li>2. Increase wire sizes, or reduce length of wiring.</li> <li>3. Request a voltage check from the power company.</li> </ol>  |
| Motor overheats.   | <ol style="list-style-type: none"> <li>1. Motor overloaded.</li> <li>2. Air Circulation through the motor restricted.</li> </ol>  | <ol style="list-style-type: none"> <li>1. Reduce load on motor.</li> <li>2. Clean out motor to provide normal air circulation through motor.</li> </ol>   |
| Motor stalls (resulting in blown fuses or tripped circuit breakers).   | <ol style="list-style-type: none"> <li>1. Short circuit in motor or loose connections.</li> <li>2. Low voltage.</li> <li>3. Incorrect fuses or circuit breakers in power line.</li> <li>4. Motor overloaded.</li> </ol>               | <ol style="list-style-type: none"> <li>1. Inspect terminals in motor for loose or shorted terminals or worn insulation on lead wires.</li> <li>2. Correct the low line voltage conditions.</li> <li>3. Install correct fuses or circuit breakers.</li> <li>4. Reduce load on motor.</li> </ol>  |
| Frequent opening of fuses or circuit breakers.   | <ol style="list-style-type: none"> <li>1. Motor overloaded.</li> <li>2. Incorrect fuses or circuit breakers.</li> </ol>   | <ol style="list-style-type: none"> <li>1. Reduce motor load.</li> <li>2. Install correct fuses or circuit breakers.</li> </ol>  |
| Machine slows down while operating   | <ol style="list-style-type: none"> <li>1. "V" Belt to loose</li> <li>2. Applying to much pressure to workpiece</li> </ol>   | <ol style="list-style-type: none"> <li>1. Adjust belt tension by pushing motor toward back until all slack is removed from belt.</li> <li>2. Ease up on pressure.</li> </ol>  |
| Abrasive belt runs off top wheel   | <ol style="list-style-type: none"> <li>1. Not tracking properly.</li> </ol>   | <ol style="list-style-type: none"> <li>1. See assembly section "Tracking Belt"</li> </ol>   |

**PARTS LIST  
FOR CRAFTSMAN 1 INCH SANDER/GRINDER  
MODEL 113.22560**

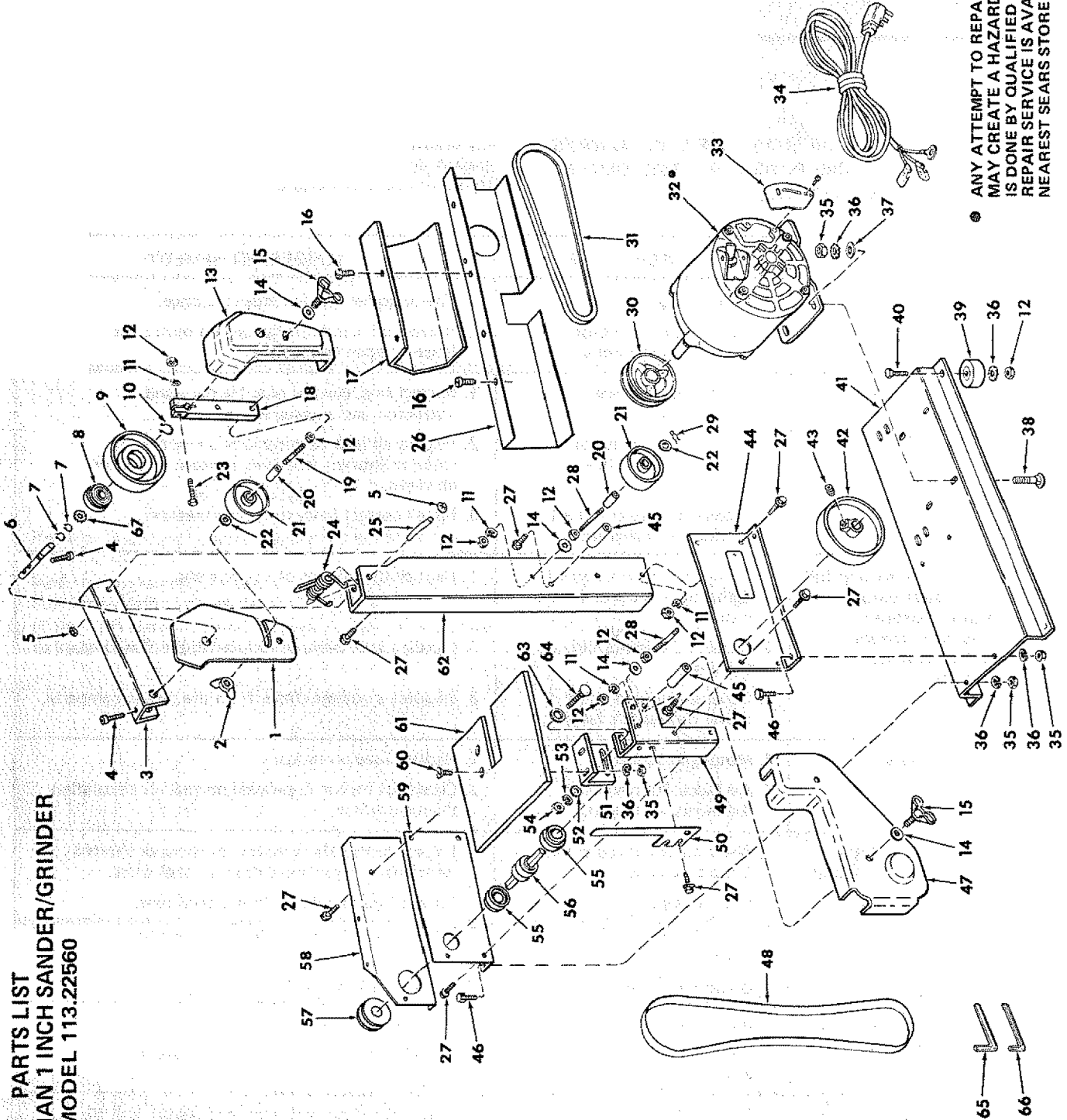

Ⓢ ANY ATTEMPT TO REPAIR THIS MOTOR  
MAY CREATE A HAZARD UNLESS REPAIR  
IS DONE BY QUALIFIED SERVICE TECHNICIAN.  
REPAIR SERVICE IS AVAILABLE AT YOUR  
NEAREST SEARS STORE.

**PARTS LIST  
FOR CRAFTSMAN 1 INCH SANDER/GRINDER  
MODEL 113.22560**

ALWAYS ORDER BY PART NO. — NOT BY KEY NO.

| Key No. | Part No.   | Description                             | Key No. | Part No.   | Description                          |
|---------|------------|---|---------|------------|--------------------------------------|
| 1       | 68042      | Guard, Back                             | 35      | STD 541231 | *Nut, Hex Jam 5/16-18                |
| 2       | STD 541710 | *Nut, Wing 10-32                        | 36      | STD 551131 | *Lockwasher, 5/16                    |
| 3       | 68023      | Bracket, Top Pivot                      | 37      | STD 551031 | *Washer, 11/32 x 3/4 x 1/16          |
| 4       | 60102      | *Screw, Hex Soc. Hd. Cap 1/4-20 x 1     | 38      | STD 533107 | *Bolt, Carriage 5/16-18 x 5/8        |
| 5       | 60240      | Nut, Push 3/8                           | 39      | 805116     | Bumper, Rubber                       |
| 6       | 68043      | Shaft, Top Arm Idler                    | 40      | STD 522506 | *Screw, M. Hex 1/4-20 x 5/8          |
| 7       | STD 582050 | *Ring, Retaining 1/2                    | 41      | 68048      | Base                                 |
| 8       | 805097     | Bearing, Ball                           | 42      | 805105     | Wheel, Drive                         |
| 9       | 805342     | Wheel, Top                              | 43      | STD 503103 | *Screw, Soc. Hd. Set 5/16-18 x 3/8   |
| 10      | 38538      | Ring, Retaining 1/2                     | 44      | 68020      | Plate, R. H.                         |
| 11      | STD 551125 | *Lockwasher, 1/4                        | 45      | 68041      | Support, Guard                       |
| 12      | STD 541025 | *Nut, Hex 1/4-20                        | 46      | STD 541408 | *Screw, M. Hex 5/16-18 x 1/2         |
| 13      | 68039      | Guard, Upper                            | 47      | 68040      | Guard, Lower                         |
| 14      | STD 551025 | *Washer, 17/64 x 5/8 x 1/16             | 48      | 68032      | †Belt, Sanding 1 x 42                |
| 15      | 30540      | Screw, Wing 1/4-20 x 1/2                | 49      | 68049      | Support, Table                       |
| 16      | STD 610805 | *Screw, Pan Hd. Ty. A No. 8 x 1/2       | 50      | 805098     | Platen, Belt                         |
| 17      | 68044      | Guard, Motor Shaft                      | 51      | 68031      | Bracket, Table                       |
| 18      | 68045      | Arm, Top                                | 52      | 120394     | *Washer, 3/8 x 7/8 x 5/64            |
| 19      | 68046      | Shaft, Idler                            | 53      | STD 551137 | *Lockwasher, 3/8                     |
| 20      | 805101     | Bearing, Sleeve                         | 54      | STD 541037 | *Nut, Hex 3/8-16                     |
| 21      | 805100     | Wheel, Idler (Includes Key No. 20)      | 55      | 805209     | Cap, Bearing                         |
| 22      | STD 551025 | *Washer, 17/64 x 5/8 x 1/32             | 56      | 805343     | Bearing, Arbor                       |
| 23      | STD 522512 | *Screw, M. Hex Hd. 1/4-20 x 1-1/4       | 57      | 805435     | Pulley, 1-1/2 x 5/8                  |
| 24      | 805091     | Spring, Torsion                         | 58      | 68027      | Bracket, Guard                       |
| 25      | 805210     | Shaft, Pivot Arm                        | 59      | 68019      | Plate, L. H.                         |
| 26      | 68047      | Guard, Belt                             | 60      | 133832     | *Screw, Mach. Flat Hd. 5/16-18 x 7/8 |
| 27      | 273229     | Screw, Hex Ind. Washer Hd. 1/4-20 x 1/2 | 61      | 68050      | Table                                |
| 28      | 805103     | Shaft, Idler                            | 62      | 68051      | Channel, Column                      |
| 29      | 805104     | Clip, Hairpin                           | 63      | 60292      | *Washer, 9/16 x 1-1/16 x 3/32        |
| 30      | 805391     | †Pulley 3" x 1/2                        | 64      | STD 533710 | *Bolt, Carriage 3/8-16 x 1           |
| 31      | STD303300  | *Belt, "V" 3/8 x 30                     | 65      | 37911      | †Wrench, Hex "L" 3/16                |
| 32      | 68037      | ●Motor                                  | 66      | 37837      | †Wrench, Hex "L" 5/32                |
| 33      | 64140      | Cover, Terminal                         | 67      | 806451     | Ring, Retaining 1-3/8                |
| 34      | 64394      | Cord w/Plug                             | ---     | 68038      | Owners Manual (not illustrated)      |

● Any attempt to repair this motor may create a hazard unless repair is done by qualified service technician.

Repair service is available at your nearest Sears store.

\* Standard Hardware Item — May be Purchased Locally.

† Stock Item — May be Secured Through the Hardware Departments of Most Sears or Simpson-Sears Retail Stores or Catalog Order Houses.

**Sears**

*owners  
manual*

**SERVICE**

**MODEL NO.  
113.22560**

**HOW TO ORDER  
REPAIR PARTS**

## 1 INCH SANDER GRINDER

Now that you have purchased your 1-inch sander grinder, should a need ever exist for repair or service, simply contact any Sears Service Center and most Sears, Roebuck and Co. stores. Be sure to provide all pertinent facts when you call or visit.

The model number of your 1-inch sander grinder will be found on the side of the base.

WHEN ORDERING REPAIR PARTS, ALWAYS GIVE THE FOLLOWING INFORMATION:

| PART NUMBER               | PART DESCRIPTION                      |
|---------------------------|---------------------------------------|
| MODEL NUMBER<br>113.22560 | NAME OF ITEM<br>1-INCH SANDER GRINDER |

All parts listed may be ordered from any Sears Service Center and most Sears stores. If the parts you need are not stocked locally, your order will be electronically transmitted to a Sears Repair Parts Distribution Center for handling.

**Sold by SEARS, ROEBUCK AND CO., Chicago, IL. 60684 U.S.A.**