

Dunkirk 

Quantum
90

**GAS-FIRED, DIRECT VENT,
CONDENSING, HOT WATER BOILER**

**INSTALLATION, OPERATION &
MAINTENANCE MANUAL**



innovative living™

An ISO 9001-2008 Certified Company

DUNKIRK BOILERS
85 Middle Rd.
Dunkirk, NY 14048
www.dunkirk.com

P/N# 14683301, Rev. C [12/2010]

90-50-100 GAS-FIRED BOILER

Model No.

90-50

90-75

90-100



**These instructions
must be affixed on or
adjacent to the boiler.**

WARNING



Improper installation, adjustment, alteration, service, or maintenance can cause injury or property damage. Refer to this manual. For assistance or additional information consult a qualified installer, service agency, or the gas supplier.

CAUTION





Read all instructions carefully before starting the installation.
Save this manual for reference.

TABLE OF CONTENTS

Warnings and Safety Symbols	3
Introduction.....	4
Boiler Ratings & Capacities	5
Boilers For Use At High Altitude	6
Rules For Safe Installation And Operation	8
Before Installing The Boiler.....	8
Placing The Boiler	11
Near Boiler Piping	12
Combustion Air and Vent Pipe	19
Gas Supply Piping.....	24
Electrical Wiring	26
Controls and Accessories	30
Water Treatment & Freeze Protection	32
Start Up	34
Operating Instructions.....	35
To Turn Off Gas To Appliance	35
Check Out Procedure and Adjustment	36
Installation and Check-Out Certificate.....	40
Maintenance And Cleaning	41
Detailed Sequence Of Operation	44
Troubleshooting.....	47
Differential Air Pressure Switch Check	55

IMPORTANT: THIS MANUAL MUST BE KEPT NEAR THE BOILER FOR FUTURE REFERENCE!!

WARNINGS AND SAFETY SYMBOLS

 <p>DANGER</p> <p>Indicates an imminently hazardous situation which, if not avoided, WILL result in death, serious injury or substantial property damage.</p>	 <p>CAUTION</p> <p>Indicates an imminently hazardous situation which, if not avoided, may result in injury or property damage.</p>
 <p>WARNING</p> <p>Indicates an imminently hazardous situation which, if not avoided, may result in death, serious injury or substantial property damage.</p>	<p>NOTICE</p> <p>Indicates information which should be followed to ensure proper installation and operation.</p>



INTRODUCTION

This appliance is a gas-fired direct vent hot water boiler with cast aluminum boiler sections. A revolutionary cast aluminum heat exchanger means better heat transfer and thermal storage than similarly sized cast iron boilers, which results in higher efficiency. The heating system water absorbs large amounts of heat from the cast aluminum heat exchanger, cooling the flue gases and causing condensation. Sealed combustion, premix gas burner, and low flame temperature means drastically reduced CO and NOx emissions, which contribute to a cleaner and healthier environment.

(sealed combustion) and does not compete with building occupants for fresh air. Sealed combustion (also known as “direct vent”) is the safest and best way to obtain plenty of clean combustion air. The induced draft fan draws in the outside combustion air, then takes the cooler flue gases from the boiler unit and provides a positive removal of the flue gases from the building through inexpensive and readily available PVC and CPVC pipes.

This appliance, unlike normal residential atmospheric and induced draft units, takes its combustion air directly from the outdoors

NOTICE

IMPORTANT: Read the following instructions COMPLETELY before installing!

Figure 1 - Boiler Dimensions

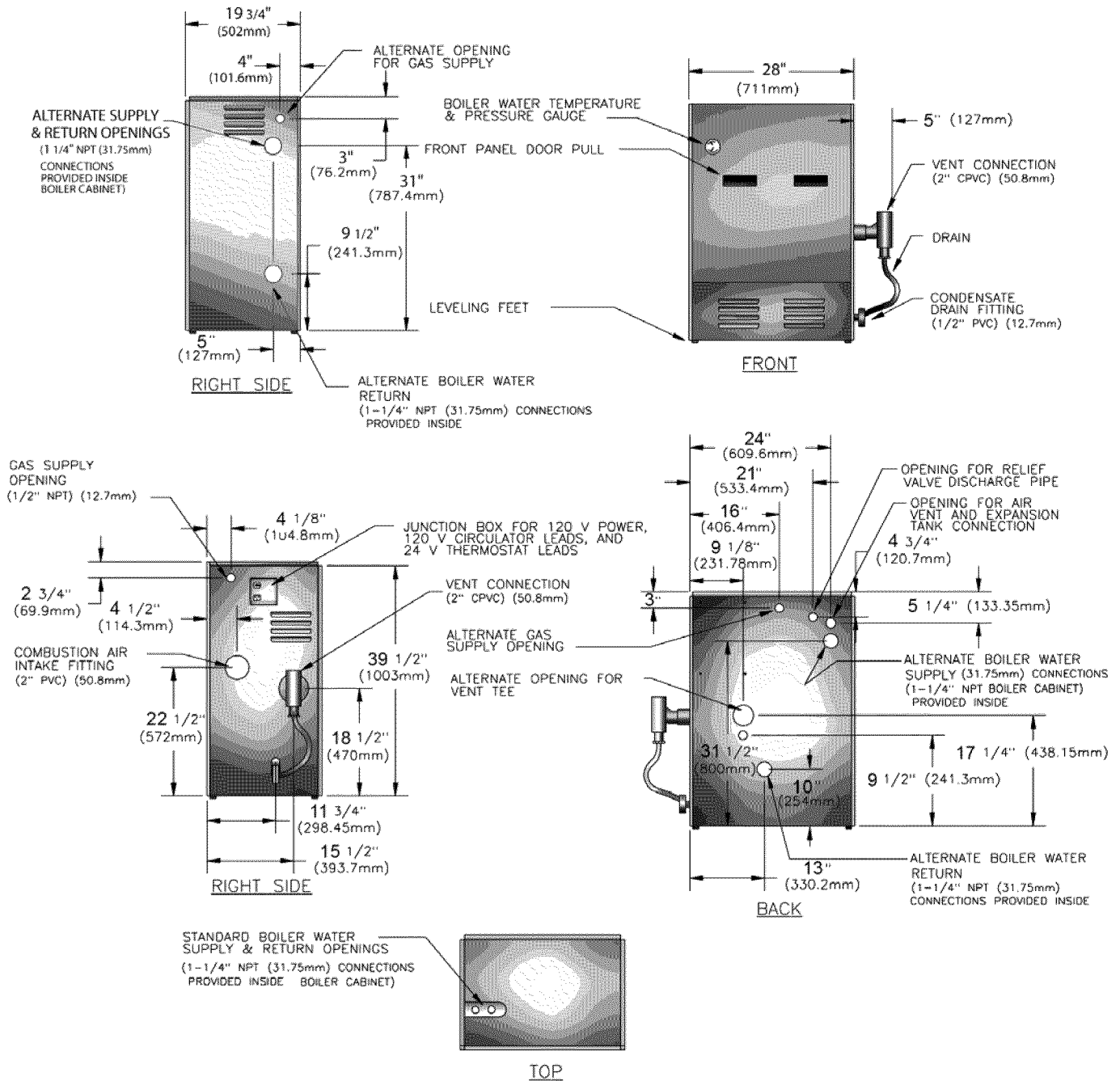

TABLE #1 – SEA LEVEL RATINGS – NATURAL AND PROPANE GASES

Model	Input *(MBH)	++ Heating Capacity *(MBH)	Net I=B=R Rating *(MBH)	Shipping Weight (lbs.)	Flue Dia.
90-50	50	45	39	220	2" CPVC & PVC
90-75	75	68	59	220	2" CPVC & PVC
90-100	100	90	78	220	2" CPVC & PVC

* 1 MBH = 1,000 Btuh Btuh = British Thermal Units Per Hour

These low pressure gas-fired hot water boilers are design certified by CSA International for use with natural and propane gases. The boilers are constructed and hydrostatically tested for a maximum working pressure of 50 psig (pounds per square inch gage) in accordance with A.S.M.E. (American Society of Mechanical Engineers) Boiler and Pressure Vessel Code Section IV Standards for heating boilers.

++ AFUE (Annual Fuel Utilization Efficiency) and Heating Capacity is based on the D.O.E. (Department of Energy) test procedure.

The Boilers are certified in accordance with ANSI (American National Standards Institute) Z21.13 standards as gas-fired, direct vent, condensing, hot water boilers.

The Heating Capacity indicates the amount of heat available after subtracting the losses up the stack. Most of this heat is available to heat water. A small portion is heat from the jacket and surfaces of the boiler, and it is assumed that this heat stays in the structure. The Net I=B=R Rating represents the portion of the remaining heat that can be applied to heat the radiation or terminal units (i.e. finned tube baseboard, cast iron radiators, radiant floor, etc.). The difference between the Heating Capacity and the Net I=B=R Rating, called the piping and pickup allowance, establishes a reserve for heating the volume of water in the system and offsetting heat losses from the piping.

The Net I=B R Ratings shown are based on a piping and pickup factor of 1.15 in accordance with the I=B=R Standard as published by the Hydronics Institute. The Net I=B=R Rating of the boiler selected should be greater than or equal to the calculated peak heating load (heat loss) for the building or area(s) served by the boiler and associated hot water heating systems. The manufacturer should be consulted before selecting a boiler for installations having unusual piping and pickup requirements.

The boilers are factory equipped for operation at altitudes ranging from 0-2,000 feet above sea level. For use of these boilers at altitudes above 2,000 feet above sea level, the gas input ratings (MBH) automatically reduced.

BOILERS FOR USE AT HIGH ALTITUDE

The boilers (with the exception of the 90-75 LP product) are factory equipped for operation at altitudes ranging from 0-10,000 feet above sea level. No changes to the factory settings are required for installations from 0-5,000 feet above sea level. For altitudes from 5,000-10,000 feet above sea level the gas manifold pressure will need to be adjusted based upon calorific (Btu) value of supply gas (contact local gas utility or distributor for this value). For specific settings refer to Table #1 for natural gas applications and **Table #2** for LP gas applications. Instructions on how to adjust the gas manifold pressure settings are shown in **Figures 17 & 18**.

Note that 90-75 LP applications for 5,000 - 10,000 feet above sea level will require an orifice change as well as a gas manifold pressure adjustment based upon calorific (Btu) value of supply gas. Refer to **Table #2** for altitude orifice kit part number. For replacing the orifice refer to specific instructions included with the kit.

TABLE #1: SERIES 90 NATURAL GAS

SERIES 90-50						
	Stock Factory	Btu Value of Natural Gas++				
	Settings	750	850	950	1000	1050
Altitude in Ft.	0-5,000	5,000-10,000				
Normal Input (MBH)	50	-	-	-	-	-
Manifold Pressure In W.C.	2.5	4	4	3.5	2.5	2.5
Orifice	43331094	43331094				
SERIES 90-75						
	Stock Factory	Btu Value of Natural Gas++				
	Settings	750	850	950	1000	1050
Altitude in Ft.	0-5,000	5,000-10,000				
Normal Input (MBH)	75	-	-	-	-	-
Manifold Pressure In W.C.	2.5	3.5	3.5	2.5	2.5	2.5
Orifice	43331092	43331092				
SERIES 90-100						
	Stock Factory	Btu Value of Natural Gas++				
	Settings	750	850	950	1000	1050
Altitude in Ft.	0-5,000	5,000-10,000				
Normal Input (MBH)	100	-	-	-	-	-
Manifold Pressure In W.C.	2.5	3.5	3.5	2.5	2.5	2.5
Orifice	43331090	43331090				
++Contact local gas utility or distributor for Btu value of gas.						

BOILERS FOR USE AT HIGH ALTITUDE

NOTICE

For model 90-75 LP units only at altitudes above 5,000 ft., install 90-75 High Altitude Orifice Kit #550001810*. For all other altitudes use factory installed orifice.

TABLE #2: SERIES 90 PROPANE GAS

SERIES 90-50						
	Stock Factory	Btu Value of LP Gas++				
	Settings	2300	2350	2400	2450	2500
Altitude in Ft.	0-5,000	5,000-10,000				
Normal Input (MBH)	50	-	-	-	-	-
Manifold Pressure In W.C.	2.5	3	3	2.5	2.5	2.5
Orifice	43331095	43331095				
SERIES 90-75*						
	Stock Factory	Btu Value of LP Gas++				
	Settings	2300	2350	2400	2450	2500
Altitude in Ft.	0-5,000	5,000-10,000				
Normal Input (MBH)	75	-	-	-	-	-
Manifold Pressure In W.C.	2.5	3.5	3.5	3.5	3	3
Orifice	43331093	43331096*				
* For model 90-75 LP units only at altitudes above 5,000 ft., install 90-75 High Altitude Orifice Kit #550001810. For all other altitudes use factory installed orifice.						
SERIES 90-100						
	Stock Factory	Btu Value of LP Gas++				
	Settings	2300	2350	2400	2450	2500
Altitude in Ft.	0-5,000	5,000-10,000				
Normal Input (MBH)	100	-	-	-	-	-
Manifold Pressure In W.C.	2.5	3	3	3	2.5	2.5
Orifice	43331091	43331091				
++Contact local gas utility or distributor for Btu value of gas.						

RULES FOR SAFE INSTALLATION AND OPERATION

1. Read the entire installation manual before beginning the installation. Failure to follow these rules for safe installation and operation and these instructions could cause a malfunction of the boiler and result in death, serious bodily injury, and/or property damage.
2. Check all applicable state and local building codes and utility company requirements before installation. The installation must conform with these requirements in their entirety. In the absence of these codes, use NFPA Installation Codes and good industry practice.
3. Before servicing the boiler - allow the boiler to cool. Always shut off any electricity and gas supply connected to the boiler prior to servicing.
4. Inspect gas line for leaks.
5. Be certain gas input rate is correct. Over firing may result in early failure of the boiler sections. This may cause dangerous operation. Under firing may result in too much air for the pre-mix burner causing poor or loss of combustion.
6. Never vent the products of combustion from this boiler to an enclosed space. Always vent to the outdoors. Never vent to another room or to inside a building.
7. Be sure there is adequate outdoor air supply to boiler for complete combustion.
8. Follow a regular service and maintenance schedule for efficient and safe operation.
9. Keep boiler area clean of debris and free of combustible and flammable materials.
10. Proper through the wall or through the roof combustion venting shall be in accordance with the materials and methods described in this manual. Installation must comply with local codes.
11. This boiler and related hot water heating systems are not do it yourself items. They must be installed and serviced by qualified professionals.

WARNING

This boiler has been equipped for residential installations. If used for commercial applications, any additional code requirements must be adhered to for installation. This may require additional controls including but not limited to a low water cut off, a manual reset high temperature limit, and wiring and/or piping modifications. The manufacturer is not responsible for any field installation changes made to a boiler installation which are not described or acknowledged in this manual.



BEFORE INSTALLING THE BOILER

Complete all of the following prior to installing the boiler. Codes

This boiler product is a gas-fired, direct vent, condensing boiler and must be installed to conform to the requirements of the authority having jurisdiction or, in the absence of such requirements:

United States - National Fuel Gas Code (NFPA-54/ANSI Z223.1).

Canada - National Gas and Propane Installation Code, Can/CSA B149.1.

Where required by the authority having jurisdiction, the installation must conform to the American Society of Mechanical Engineers Safety Code for Controls and Safety Devices for Automatically Fired Boilers, No.CSD-1.

NOTICE

Important - In the state of Massachusetts this product must be installed by a licensed plumber or gas fitter and the installation must be in accordance with 248 CMR.

Installers - Follow local regulations with respect to installation of CO (Carbon Monoxide) Detectors. Follow maintenance recommendations in this manual.

Installation Requirements Specific To The State Of Massachusetts For Direct Vent, Mechanical Vent, And Domestic Hot Water Appliances

For all side wall horizontally vented gas fueled equipment installed in every dwelling, building or structure used in whole or in part for residential purposes, including those owned or operated by the commonwealth and where the side wall exhaust vent termination is less than seven (7) feet above finished grade in the area of the venting, including but not limited to decks and porches, the following requirements shall be satisfied:

1. Installation of carbon monoxide detectors: at the time of installation of the side wall horizontal vented gas fueled equipment, the installing plumber or gasfitter shall observe that a hard wired carbon monoxide detector with an alarm and battery back-up is installed on the floor level where the gas equipment is to be installed. In addition, the installing plumber or gasfitter shall observe that a battery operated or hard wired carbon monoxide detector with an alarm is installed on each additional level of the dwelling, building or structure served by the side wall horizontal vented gas fueled equipment. It shall be the responsibility of the property owner to secure the services of qualified licensed professionals for the installation of hard wired carbon monoxide detectors.

- A. In the event that the side wall horizontally vented gas fueled equipment is installed in a crawl space or an attic, the hard wired carbon monoxide detector with alarm and battery back-up may be installed on the next adjacent floor level.
 - B. In the event that the requirements of this subdivision can not be met at the time of completion of installation, the owner shall have a period of thirty (30) days to comply with the above requirements; provided, however, that during said thirty (30) day period, a battery operated carbon monoxide detector with an alarm shall be installed.
2. Approved carbon monoxide detectors: each carbon monoxide detector as required in accordance with the above provisions shall comply with NFPA720 and be ANSI/UL 2034 listed and IAS certified.
 3. Signage: a metal or plastic identification plate shall be permanently mounted to the exterior of the building at a minimum height of eight (8) feet above grade directly in line with the exhaust vent terminal for the horizontally vented gas fueled heating appliance or equipment. The sign shall read, in print size no less than one-half (1/2) inch in size, "gas vent directly below. Keep clear of all obstructions".
 4. Inspection: the state or local gas inspector of the side wall horizontally vented gas fueled equipment shall not approve the installation unless, upon inspection, the inspector observes carbon monoxide detectors and signage installed in accordance with the provisions of 248 CMR 5.08(2)(A)1 through 4.
 5. Product-approved vent/air-intake: a product-approved vent terminal must be used and, if applicable, a product-approved air intake must be used. Installation shall be in strict compliance with the manufacturer's instructions.
 6. Installation instructions: a copy of all installation instructions for all product approved side wall horizontally vented gas fueled equipment, all venting instructions, all parts lists for venting instructions, and/or all venting design instructions shall remain with the appliance or equipment at the completion of the installation.

Boiler Sizing

Check to be sure you have selected the boiler with the proper capacity before starting the installation. The I=B=R Rating of the boiler selected should be greater than or equal to the calculated peak heating load (heat loss) for the building or area(s) served by the boiler and associated hot water heating systems. See the table "BOILER RATINGS AND CAPACITIES" (page 5 of this document).

Heat loss calculations should be based on approved industry methods.

Considerations For Boiler Location

Before selecting a location for the boiler, the following should be considered. Each boiler considered.

- Supplied with the correct type of gas (natural gas or propane).
- Connected to a suitable combustion air intake piping system to supply the correct amounts of fresh (outdoor) air for combustion, refer to Combustion Air And Vent Pipe section (near center of this manual) for details.
- Connected to a suitable venting system to remove the hazardous products of gas combustion, refer to Combustion Air And Vent Pipe section (page 19 of this manual) for details.
- Connected to a suitable hot water heating system.
- Supplied with a suitable electrical supply for all boiler motors and controls.
- Connected to a properly located thermostat or operating control. (not included with boiler)
- Placed on level surface (must NOT be installed on carpeting)
- Condensate drain line must be pitched down to floor drain or external condensate pump with reservoir at ¼" per foot (wood frame or blocks may be used to raise boiler).

Locating The Boiler

1. Select a location which is level, central to the piping systems served and as close to the vent and air intake terminals as possible.
2. Accessibility clearances, if more stringent (i.e. larger clearances) than required fire protection clearances, must be used for the boiler installation. Accessibility clearances may be achieved with the use of removable walls or partitions.
3. The boiler is approved for installation in closets and on combustible floors. This boiler shall NOT be installed on carpeting.
4. The clearances shown in **Table #2** indicate required clearances. A minimum 1" clearance must be maintained between combustible construction and each of the left, top and back surfaces of the boiler. A minimum 8" clearance is required on the right side, to allow room for the inlet air pipe. An 18" clearance must be maintained at a side where passage is required to access another side for cleaning or servicing, inspection or replacement of any parts that normally may require such attention. Allow at least 24" at the front and left side and 8" at the top for servicing. No clearances are required to venting or combustion air intake piping.
5. Equipment shall be installed in a location which facilitates the operation of venting and combustion air intake piping systems as described in this manual.

6. Advise owner of boiler to keep venting and combustion air intake passages free of obstructions. both the venting and combustion air intake piping systems connected to the outdoors must permit flow through the piping systems without restrictions for the boiler to operate.
7. The boiler shall be installed such that the automatic gas ignition system components are protected from water (dripping, spraying, rain, etc.) during operation and service (circulator replacement, condensate trap, control replacement, etc.).

sphere, and all flue products are discharged to outside atmosphere. Combustion air and vent pipe connections must terminate together in the same atmospheric pressure zone, either through the roof or sidewall (roof termination preferred). See **Figures 9 & 10** (in Combustion Air And Vent Pipe section of this manual) for required clearances.

CAUTION



Keep boiler area clean of debris and free of flammable and combustible materials, vapors and liquids.

Combustion Air And Vent Pipe Requirements

This boiler requires a dedicated direct vent system. In a direct vent system, all air for combustion is taken directly from outside atmo-

TABLE #2 - Required Clearances

Unit	Combustible Clearance <i>Inch (mm)</i>	Accessibility, Cleaning, and Servicing <i>Inch (mm)</i>
Top	1 (25.4)	8 (203.2)
Left Side	1 (25.4)	24 (609.6)
Right Side	8 (203.2)	-
Base	1 (25.4)	-
Front	1 (25.4)	24 (609.6)
Back	1 (25.4)	-
Intake/Vent Piping	0 (0)	-
Near Boiler Hot Water Piping	1 (25.4)	-

All distances measured from the cabinet of the boiler.

WARNING

When vent pipe is exposed to temperatures below freezing, such as when it passes through an unheated space or when a chimney is used as a raceway, vent pipe must be insulated with 1/2" Armaflex or equivalent. In extreme cold climate areas, use 3/4" Armaflex or equivalent.

Combustion air must be clean outdoor air. Combustion air must not be taken from inside structure because that air frequently is contaminated by halogens, which include fluorides, chlorides, phosphates, bromides and iodides. These elements are found in aerosols, detergents, bleaches, cleaning solvents, salts, air fresheners, paints, adhesives and other household products.



Locate combustion air inlet as far away as possible from swimming pool and swimming pool pump house.

All combustion air and vent pipes must be airtight and watertight. Combustion air and vent piping must also terminate exactly as shown in **Figure 9 or 10** (in Combustion Air And Vent Pipe section, page 19 of this manual).

Vent connections serving appliances vented by natural draft shall not be connected into any portion of mechanical draft systems operating under positive pressure.

Solvent cements are combustible. Keep away from heat, sparks, and open flame. Use only in well ventilated areas. Avoid breathing in vapor or allowing contact with skin or eyes.

FAILURE TO FOLLOW THE AFOREMENTIONED WARNINGS COULD RESULT IN FIRE, PROPERTY DAMAGE, PERSONAL INJURY, OR DEATH.

Condensate Drain Requirements

Condensate drain line to be pitched down to floor drain at a minimum of ¼" per foot. An external condensate pump (not furnished) may be used if floor drain is not available. The condensate pump must be designed for flue gas condensate application.

NOTICE

1. Condensate trap is built into the boiler, an external trap is not required and should not be used.
2. Wood frame or blocks may be used to raise the boiler to maintain drain pitch or to be above external condensate pump reservoir.
3. There is a 115 Volt AC receptacle provided on the service switch junction box which is located at the boiler right side, to provide power for an external condensate pump (if needed).

Foundation Requirements

Boiler must be placed on level surface. Boiler is NOT to be installed on carpeting.

NOTICE

If boiler is not level condensate drain lines will not function properly. Adjustable feet are located on the boiler to make up for minor surface irregularities or tilt.

Wood frame or blocks may be used to raise boiler to maintain drain pitch or to be above external condensate pump reservoir.

Removal of Existing Boiler From Common Vent System

When an existing boiler is removed from a common venting system, the common venting system is likely to be too large for proper venting of the appliances remaining connected to it. At the time of re-

moval of an existing boiler, the following steps shall be followed with each appliance remaining connected to the common venting system placed in operation, while the other appliances remaining connected to the common venting system are not in operation.

1. Seal any unused openings in the common venting system.
2. Visually inspect the venting system for proper size and horizontal pitch and determine there is no blockage, or restrictions, leakage, corrosion and other deficiencies which could cause an unsafe condition.
3. In-so-far as is practical, close all building doors and windows and all doors between the space in which the appliances remaining connected to the common venting system are located and other spaces of the building. Turn on clothes dryer and any appliance not connected to the common venting system. Turn on any exhaust fans, such as range hoods and bathroom exhaust, so they will operate at maximum speed. Do not operate a summer exhaust fan. Close fire dampers.
4. Place in operation the appliance being inspected. Follow the lighting instructions. Adjust thermostat so appliances will operate continuously.
5. Test for spillage at the draft hood relief opening after 5 minutes of main burner operation. Use the flame of a match or candle, or the smoke from a cigarette, cigar or pipe.
6. After it has been determined that each appliance remaining connected to the common venting system properly vents when tested as outlined above, return doors, windows, exhaust fans, fire place dampers, and any other gas-burning appliance to their previous condition of use.
7. Any improper operation of the common venting system should be corrected so the installation conforms with the National Fuel Code, NFPA-54/ANSI-Z223.1 and/or the Natural Gas and Propane Installation Code, CAN/CSA B149.1. When resizing any portion of the common venting system, the common venting system should be resized to approach the minimum size as determined using the appropriate tables in Chapter 13 of the National Fuel Gas Code, NFPA-54/ANSI-Z223.1 and/or the Natural Gas and Propane Installation Code, CAN/CSA B149.1.

PLACING THE BOILER

The boiler should be placed to provide the most direct connections to the combustion air, vent and system piping as possible.

Place crated boiler as close to selected location as possible and uncrate boiler. The uncrated boiler may be moved into position with an appliance dolly or 2-wheel hand truck. The dolly or hand truck should be inserted under the left hand side of the boiler. It is possible to slide the boiler for a short distance on a smooth floor or surface.

NOTICE

Refer to manual section "locating the boiler" (page 9 of this manual), for required clearances for servicing and maintenance.

NEAR BOILER PIPING

When the installation of the boiler is for a new heating system, first install all of the radiation units (panels, radiators, baseboard, or tubing) and the supply and return mains. After all heating system piping and components have been installed, make final connection of the system piping to the boiler. A hot water boiler installed above radiation level, or as required by the Authority having jurisdiction, must be equipped with a low water cut off device. A periodic inspection is necessary for flushing of float type devices, per low water cut off manufacturers specific instructions.

Supply And Return Lines

The packaged boiler unit is set up to receive 1 ¼" NPT supply and return piping from top access. The boiler unit can also be piped from the left side by turning the supply elbow, and from the rear of the unit by removing plugs in the rear boiler section.

NOTICE

The circulator pump and isolation valves are furnished within a carton inside the boiler cabinet and can be installed at the installer preferred location.

CAUTION

Copper supply and return piping must NOT be installed directly into aluminum boiler section casings due to galvanic corrosion between dissimilar metals. Iron or steel bushings or pipe nipples should be used between copper system piping and boiler to make final connection to boiler. Also, the use of dielectric unions is acceptable. The packaged boiler is furnished with iron piping in the front boiler section for the supply and return connections.



Figure 2 - Single Zone Boiler Piping

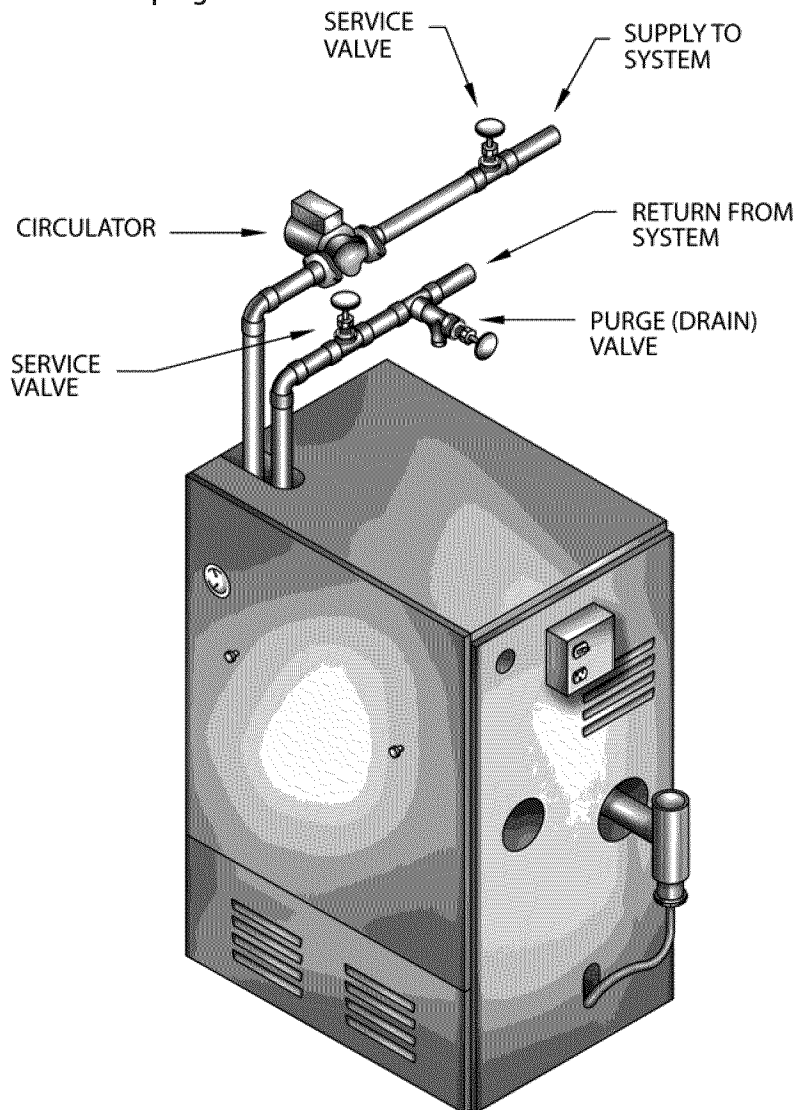

Figure 3 - Multi-zone Boiler Piping With Zone Valves

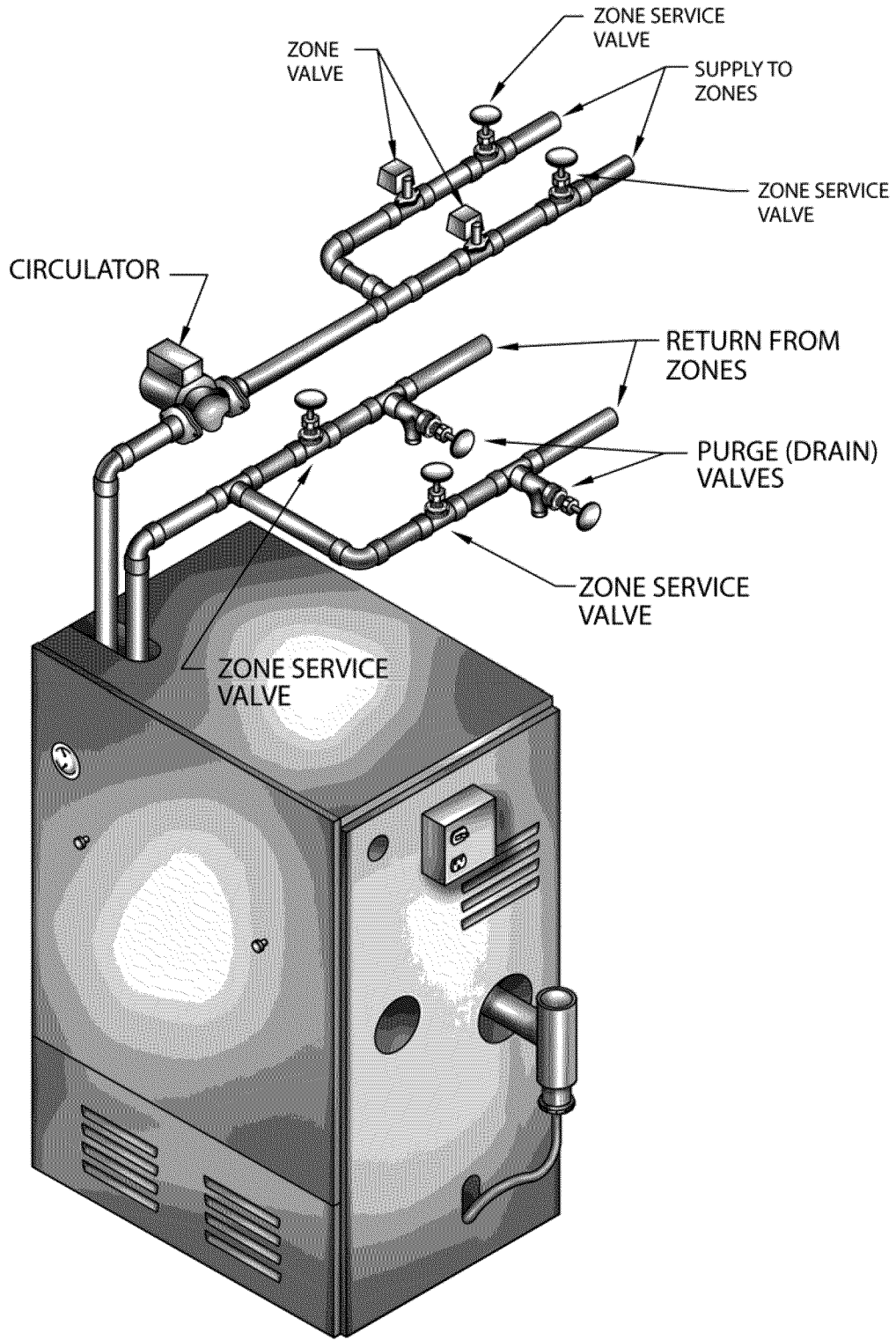
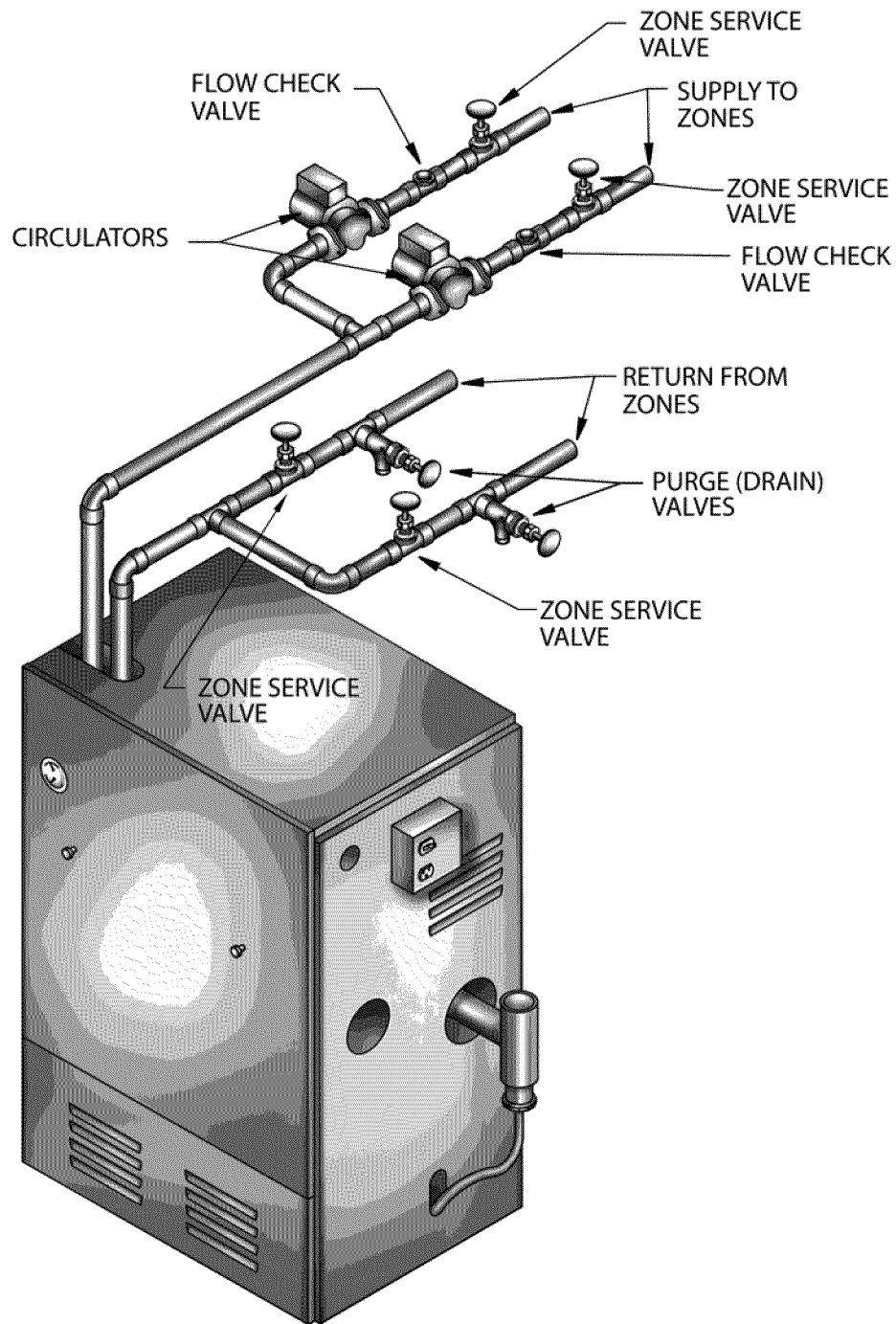
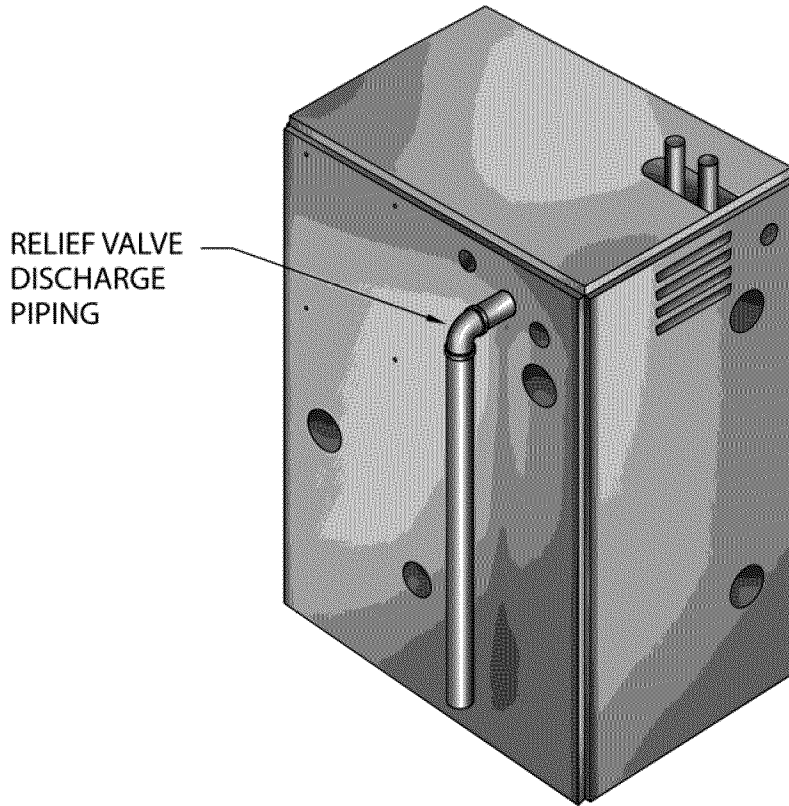

Figure 4 - Multi-Zone Boiler Piping With Circulators

**NOTICE**

When zoning with circulators, the furnished circulator pump should be used as one of the zone pumps. Each stripped end of the electrical wires for the circulator pump inside the junction box should be taped or wire nipped to prevent short circuits. Unplug the circulator pump wiring at the integrated boiler control.

Figure 5 - Single Zone Boiler Piping



Pressure Relief Valve

The boiler is furnished with a factory installed relief valve in the top of the boiler. Provide $\frac{3}{4}$ " piping from the supplied relief valve to a local floor drain, but leave an air gap between piping and drain. No shutoff of any description shall be placed between safety relief valve and the boiler, or on the discharge pipes between such safety valve and the atmosphere. Installation of the safety relief valve shall conform to ANSI/ASME Boiler and Pressure Vessel Code, Section IV. The manufacturer is not responsible for any water damage.

Expansion Tank And Make-Up Water

Determine required system fill pressure, system design temperature, and system water content. Boiler contains 2.6 gallons (U.S.). Size expansion tank accordingly. Consult expansion tank manufacturer for proper sizing information. Connect properly sized expansion tank (not furnished) as shown in **Figure 6** for diaphragm type expansion tank and **Figure 7** for conventional closed type expansion tanks. For diaphragm type expansion tanks, adjust the tank air pressure to match the system fill pressure. Install air vent (furnished) as shown for diaphragm type expansion tank system only. Install make-up water connections as shown per local codes. If a pressure reducing valve is used, adjust to match the system fill pressure. In connecting the cold make-up water supply to the boiler, make sure that clean water supply is available. When the water supply is from a well or pump, sand strainer should be installed at the pump.

Figure 6 - Diaphragm Type Expansion Tank Piping

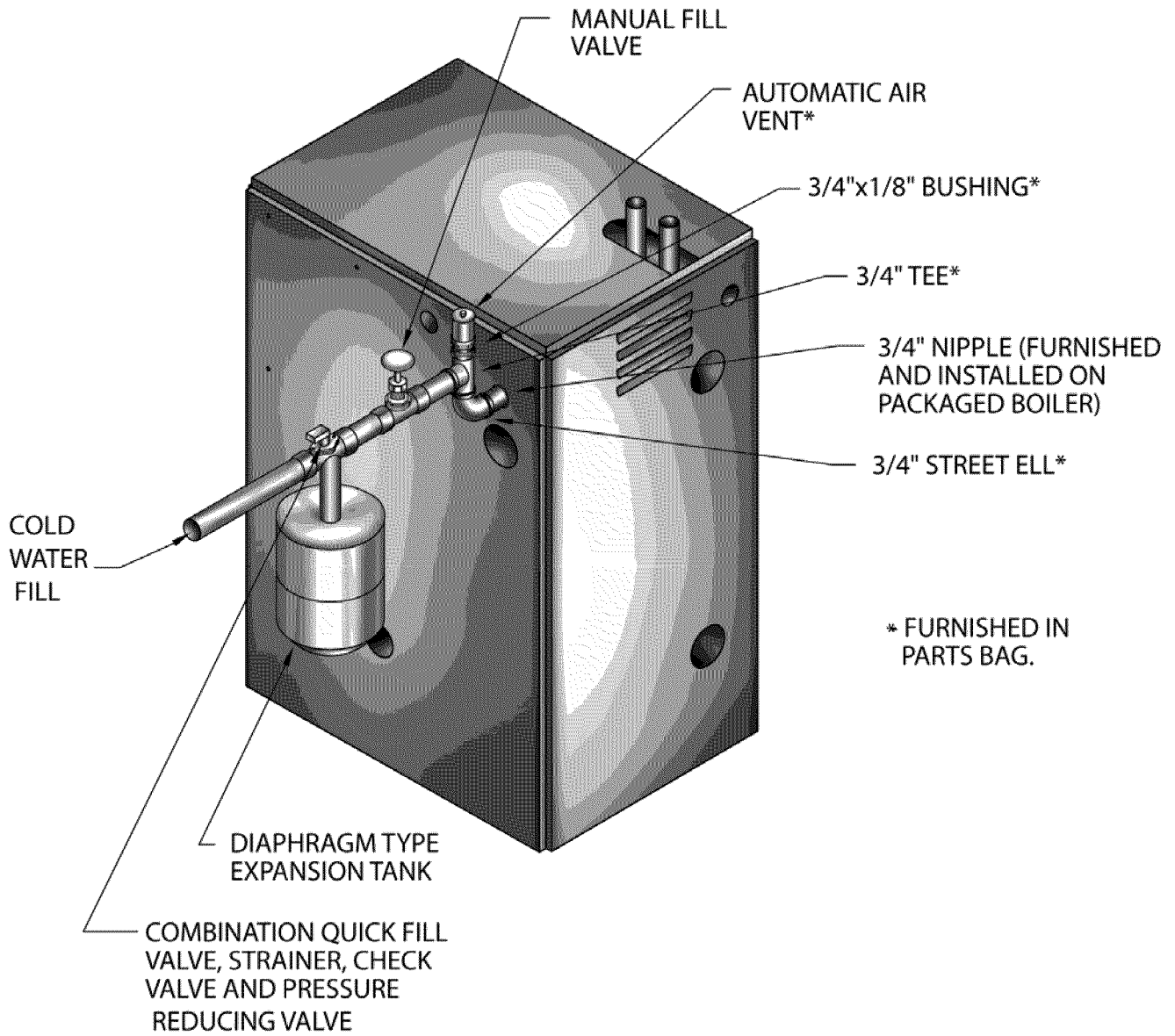

Figure 7 - Conventional (closed type) Expansion Tank Piping

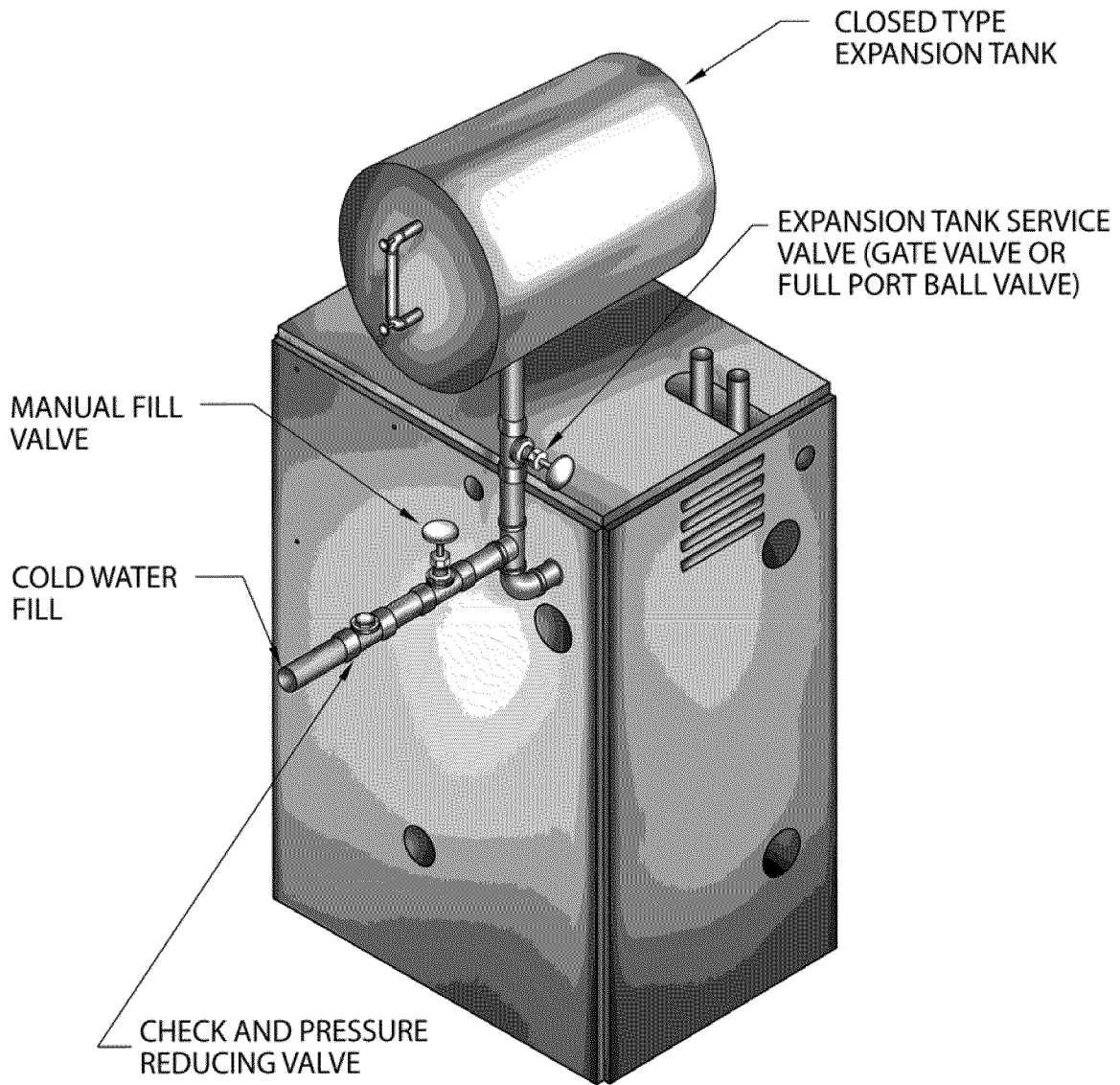
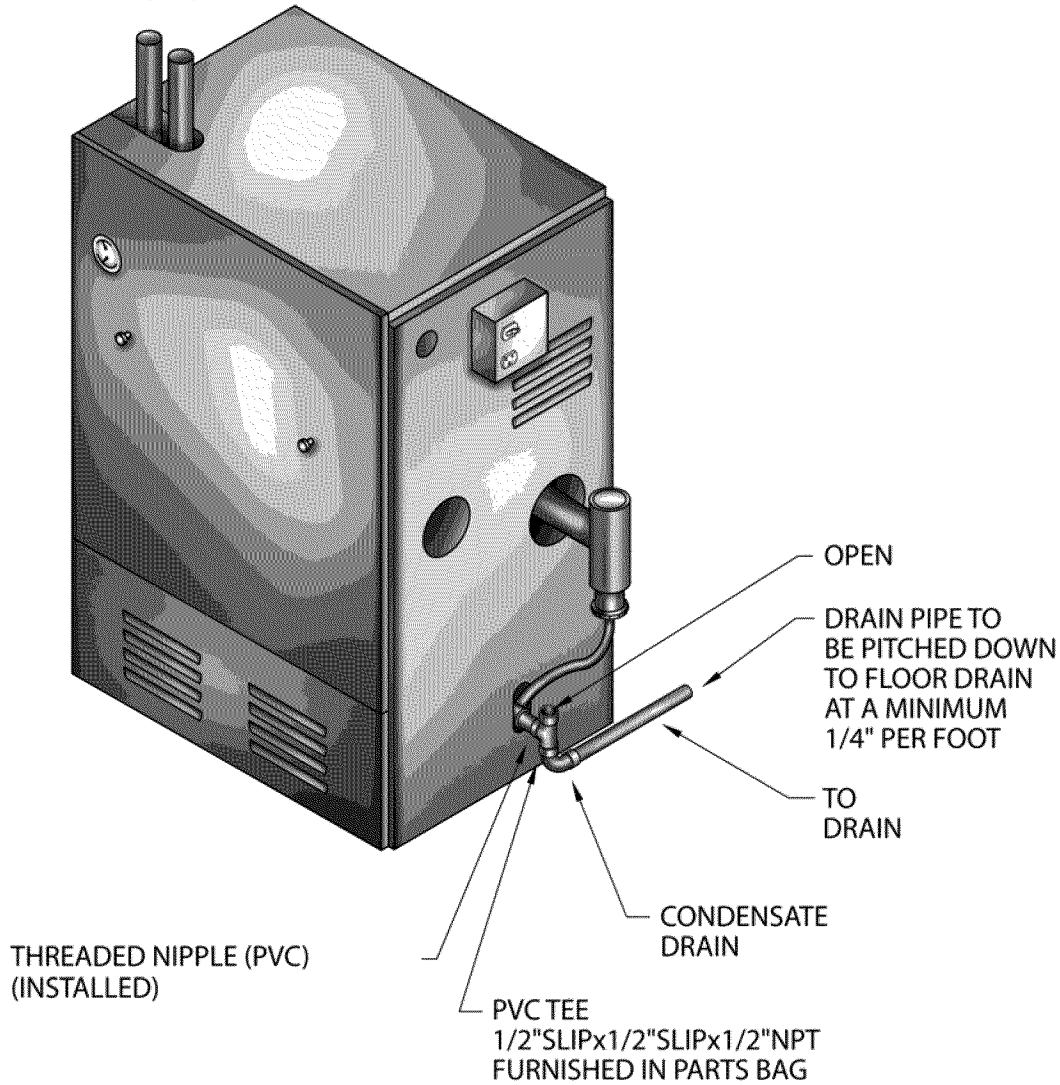

Figure 8 - Condensate Drain Piping



Condensate Drain Piping

The condensate trap is built into the boiler, an external trap is not required and should NOT be used.

Provide 1/2" PVC condensate drain and fittings. Condensate drain to be pitched down to floor drain at a minimum of 1/4" per foot.

Install furnished 1/2" PVC tee to overflow fitting as shown in **Figure 8**.

The 1/2" diameter schedule 40 PVC or CPVC condensate drain and pipe fittings must conform to ANSI standards and ASTM D 1785 or D2846. Schedule 40 PVC or CPVC cement and primer must conform to ASTM D2564 or F493. In Canada, use CSA or ULC certified schedule 40 PVC or CPVC drain pipe cement.

A condensate pump with a reservoir (not furnished) may be used to remove condensate to a drain line (sanitary line) above boiler if a floor drain is not available or its in accessible.

Filling Condensate Trap With Water

On The Initial Start Up The Condensate Trap Must Be Manually Filled With Water.

The following are the steps required to initially fill the condensate trap for start up, these steps are only required at the initial start up or if maintenance requires draining of the condensate trap:

1. Disconnect the vent condensate drain line from the bottom of the vent tee on the boiler.
2. Pour about 1 cup of cold tap water into the vent drain line with a proper funnel.
3. Excess water should go through the overflow and out through the condensate drain line. Verify proper operation of the drain line (or external condensate pump if used).
4. Reinstall the vent drain line.

Chilled Water Piping

The boiler, when used in connection with a refrigeration system, must be installed so the chiller medium is piped in parallel with the boiler with appropriate valves to prevent the chilled medium from entering the boiler.

The boiler piping system of a hot water boiler connected to heating coils is located in air handling units where they may be exposed to refrigerated air circulation must be equipped with flow control valves or other automatic means to prevent gravity circulation of the boiler water during cooling cycle.

COMBUSTION AIR AND VENT PIPE

Connections And Termination

Provisions for combustion and ventilation air must be in accordance with section, Air For Combustion and Ventilation, of the National Fuel Gas Code, ANSI 2223.1/NFPA54, or Sections 8.2, 8.3 or 8.4 of National Gas and Propane Installation Code, CAN/CGA-B 149.1 , or applicable provisions of the local building code.

These boilers require a dedicated direct vent system. All air for combustion is taken directly from outdoors through the combustion air intake pipe. All flue products are discharged to the outdoors through the vent pipe.

1. Refer to Combustion Air And Vent Pipe section that follows, also see **Figures 9 & 10** for combustion air and vent pipe roof and sidewall termination. (Roof termination is preferred) Combustion air and vent pipes must terminate together in same atmospheric pressure zone as shown. Construction through which vent and air intake pipes may be installed is a maximum 24 inches, minimum ¼” thickness.
2. Combustion air and vent pipe fittings must conform to American National Standards Institute (ANSI) standards and American Society for Testing and Materials (ASTM) standards D1784 (schedule-40 CPVC), D1785 (schedule-40 PVC), D2665 (PVC-DWV), D2241 (SDR-21 and SDR-26 PVC), D2661 (ABS-DWV), or F628 (schedule-40 ABS). Pipe cement and primer must conform to ASTM standards D2564 (PVC) or D2235 (ABS).

In Canada construct all combustion air and vent pipes for this unit of CSA or ULC certified schedule-40 CPVC, schedule-40 PVC, PVC-DWV or ABS-DWV pipe and pipe cement. SDR pipe is NOT approved in Canada.

3. Combustion air and vent piping connections on boiler are sized for 2” pipe. Any pipe size change (to 3”) must be made outside of the boiler casing in a vertical run of pipe to allow for proper drainage of vent condensate. Due to potential for flue gas temperatures over 155°F, the first five (5) feet of vent pipe must be CPVC, the remaining vent pipe can be PVC. If any elbows are employed within the first 5 feet of vent, they must be CPVC too. Two (2) - 30” pieces of 2” CPVC pipe are furnished with the boiler.

NOTICE

The transition from 2” pipe to 3” pipe must be made in a vertical run.

MAXIMUM ALLOWABLE TEMPERATURES OF TYPICAL NON-METALLIC VENT MATERIAL					
Material	HDT		RTI		Standard
	°F	°C	°F	°C	
PVC	158	70	-	-	ASTM F891 * ASTM D2665 ** ASTM D1785 ** ASTM D2241 **
CPVC	210	100	-	-	ASTM D2846 ** ASTM F441 ** ASTM F442 **
ABS	180	82	-	-	ASTM D2661 *** ASTM F628 ***
Radel - A200	414	212	-	-	UL-1738 ULC S636

* Allowable temperatures based on Classifications covered in ASTM D4396 [Deflection Temperatures under Load (264 psi) (1819KPa)].
 ** Allowable temperatures based on Classifications covered in ASTM D1784 [Deflection Temperatures under Load (264 psi) (1819KPa)].
 *** Allowable temperatures based on Classifications covered in ASTM D3965 [Deflection Temperatures under Load (264 psi) (1819KPa)].

4. Combustion air and vent piping lengths:

COMBUSTION AIR AND VENT PIPING LENGTHS				
BOILER SIZE	2" PIPE MINIMUM VENTING	2" PIPE MAXIMUM VENTING	3" PIPE MINIMUM VENTING	3" PIPE MAXIMUM VENTING
100	2 FEET	21 FEET	15 FEET	92 FEET
75 & 50	2 FEET	26 FEET	20 FEET	112 FEET

The first 5 ft. of "TOTAL EQUIVALENT LENGTH" of vent piping run must be 2" CPVC:

The length of pipe is counted from the boiler jacket (air intake pipe) or from vent tee (vent pipe) the termination is not counted toward the "Total Equivalent Length".

For additional elbows, reduce the maximum vent length as shown:

- 2" 90° elbow - 1 ½ ft. per additional elbow.
- 3" 90° elbow - 3 ft. per additional elbow.

Example:

To add 2 additional 90° elbows to a 3" pipe for a 75 boiler. Each elbow is 3 additional ft. per 90° elbow for a total of 6 ft..

(1 elbow @ 3 ft. + 1 elbow @ 3 ft. = 6 additional ft. of pipe)

The total additional pipe is then subtracted from the maximum allowable pipe length to give the new maximum length of 94 ft. with 6, 90° elbows.

("TOTAL EQUIVALENT LENGTH"):

Original 100 ft. max. - 6 ft. for 2 additional elbows = new 94 ft. maximum length.

5. Combustion air and vent piping to be pitched back to boiler at minimum ¼" per ft. (21 mm/m) from intake and vent terminals so that all moisture in combustion air and vent piping drains to boiler. Pipes must be pitched continuously with no sags or low spots where moisture can accumulate and block the flow of air or flue gas. Combustion air and vent pipes must be airtight and watertight.
6. Consideration for the following should be used when determining an appropriate location for termination of combustion air and vent piping.
 - Comply with all clearances required as stated in paragraph 7.
 - Termination should be positioned where vent vapors will not damage plants/shrubs or air conditioning equipment.
 - Termination should be positioned so that it will not be effected by wind eddy, air born leaves, snow, or recirculated flue gases.

- Termination should be positioned where it will not be subjected to potential damage by foreign objects, such as stones, balls, etc..
 - Termination should be positioned where vent vapors are not objectionable.
 - Put vent on a wall away from the prevailing winter wind. Locate or guard the vent to prevent accidental contact with people or pets.
 - Terminate the vent above normal snowline. Avoid locations where snow may drift and block the vent. Ice or snow may cause the boiler to shut down if the vent becomes obstructed.
 - Under certain conditions, flue gas will condense, forming moisture, and may be corrosive. In such cases, steps should be taken to prevent building materials at the vent from being damaged by exhaust of flue gas.
 - Vent shall not terminate where it may cause hazardous frost or ice accumulations on adjacent property surfaces.
7. The venting system shall terminate at least 3 ft. (0.9m) above any forced air inlet (except the boiler's combustion air inlet) within 10 ft.(3m). The venting system shall terminate at least 12 in. from any air opening into any building. The bottom of the vent shall be located at least 12 in. above grade. Termination of the vent shall be not less than 7 ft. (2.1m) above an adjacent public walkway or paved driveway. The vent terminal shall not be installed closer than 3 ft. from the inside corner of an L shaped structure. Termination of the vent should be kept at least 3 ft. away from vegetation.

USA only. The venting system shall terminate at least 4 ft. horizontally from, and in no case above or below, unless a 4 ft. (1.22m) horizontal distance is maintained, from electric meters, gas meters, regulators, and relief equipment.

Canada only. The venting system shall terminate at least 6 ft. (1.83m) horizontally from, an in no case above or below, unless a 6 ft. (1.83m) horizontal distance is maintained, from electric meters, gas meters, regulators, and relief equipment.

Figure 9 - Roof Vent / Intake terminations

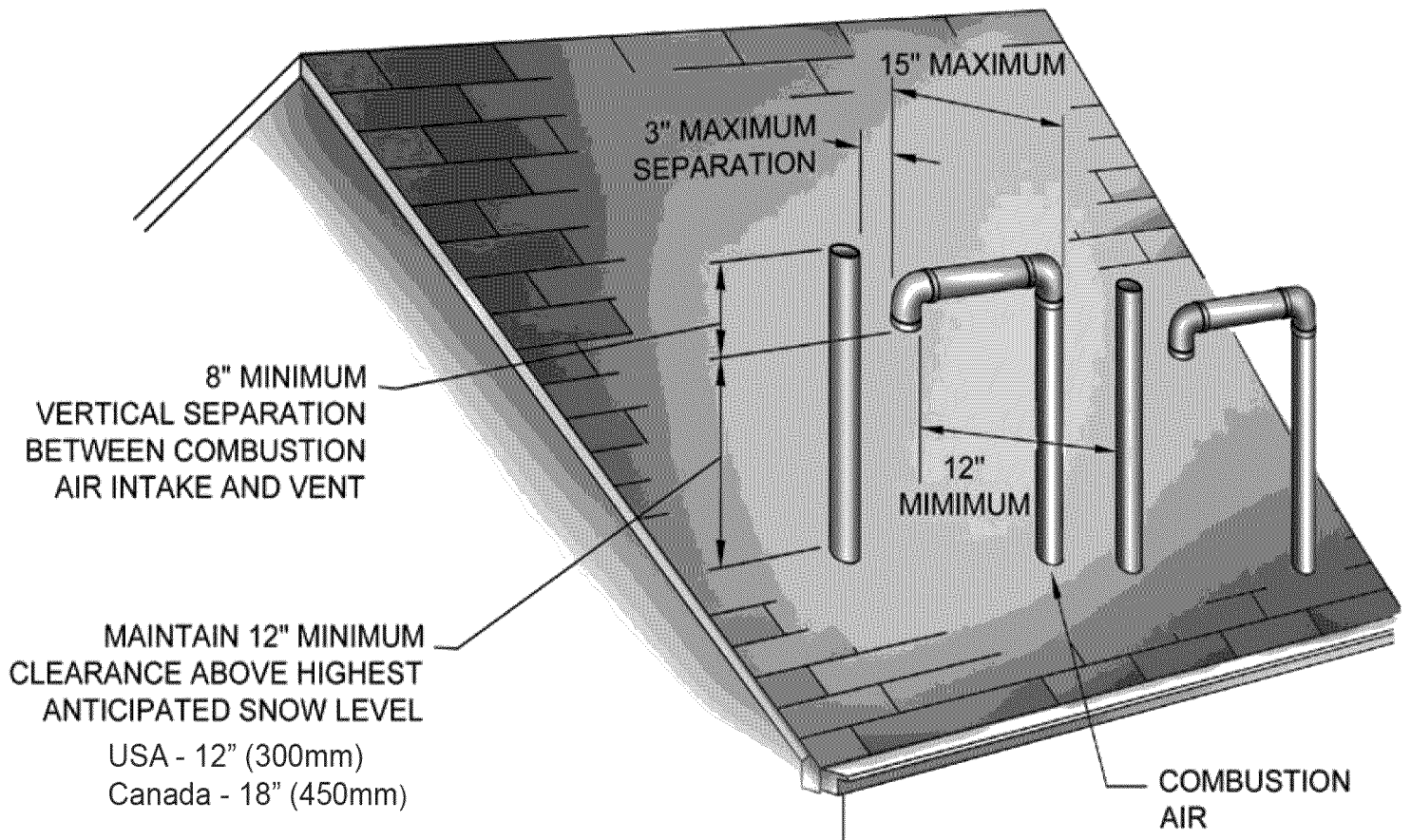

- Vent shall not terminate with 6 ft. (1.8m) of a mechanical air-supply inlet to any building.
- Vent shall not terminate above a regulator within 3 ft. (900 mm) horizontally of the vertical centerline of the regulator vent outlet to a maximum vertical distance of 15ft (9.5m).
- Vent shall not terminate within 3 ft. (900mm) of a window or door that can be opened in any building, or any non-mechanical air-supply inlet to any building, or of the combustion air inlet of any other appliance.
- Vent shall not terminate underneath a veranda, porch or deck unless, (a) the veranda, porch or deck is fully open on a minimum of two sides beneath the floor, and (b) the distance between the top of the vent termination and the underside of the veranda, porch or deck is greater than 1 ft. (300mm).

Figure 10A - Side Wall Vent / Intake terminations - Less Than 12" Clearance Above Grade

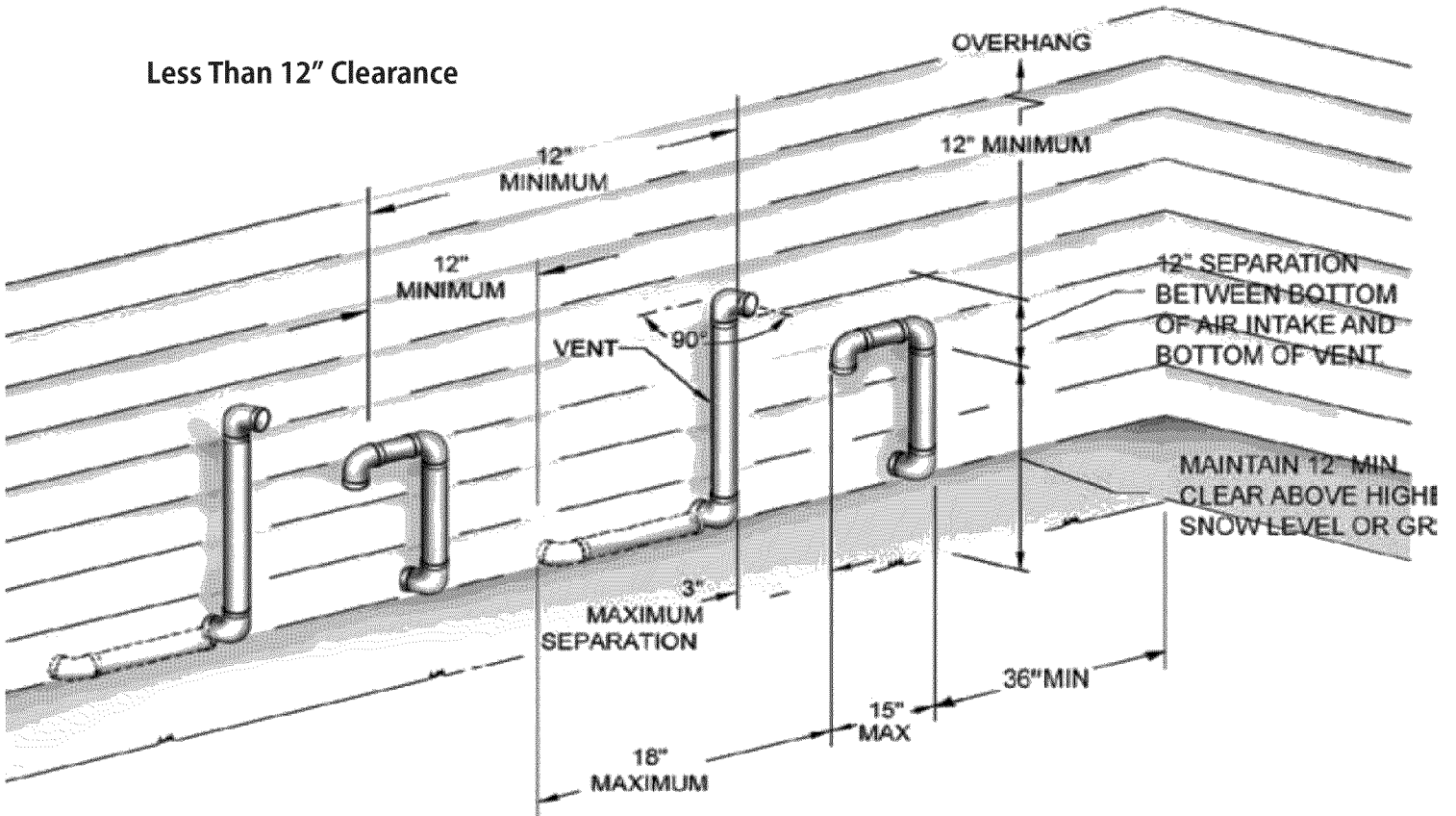

Figure 10B - Side Wall Vent / Intake Terminations - 12" Or More Clearance Above Grade

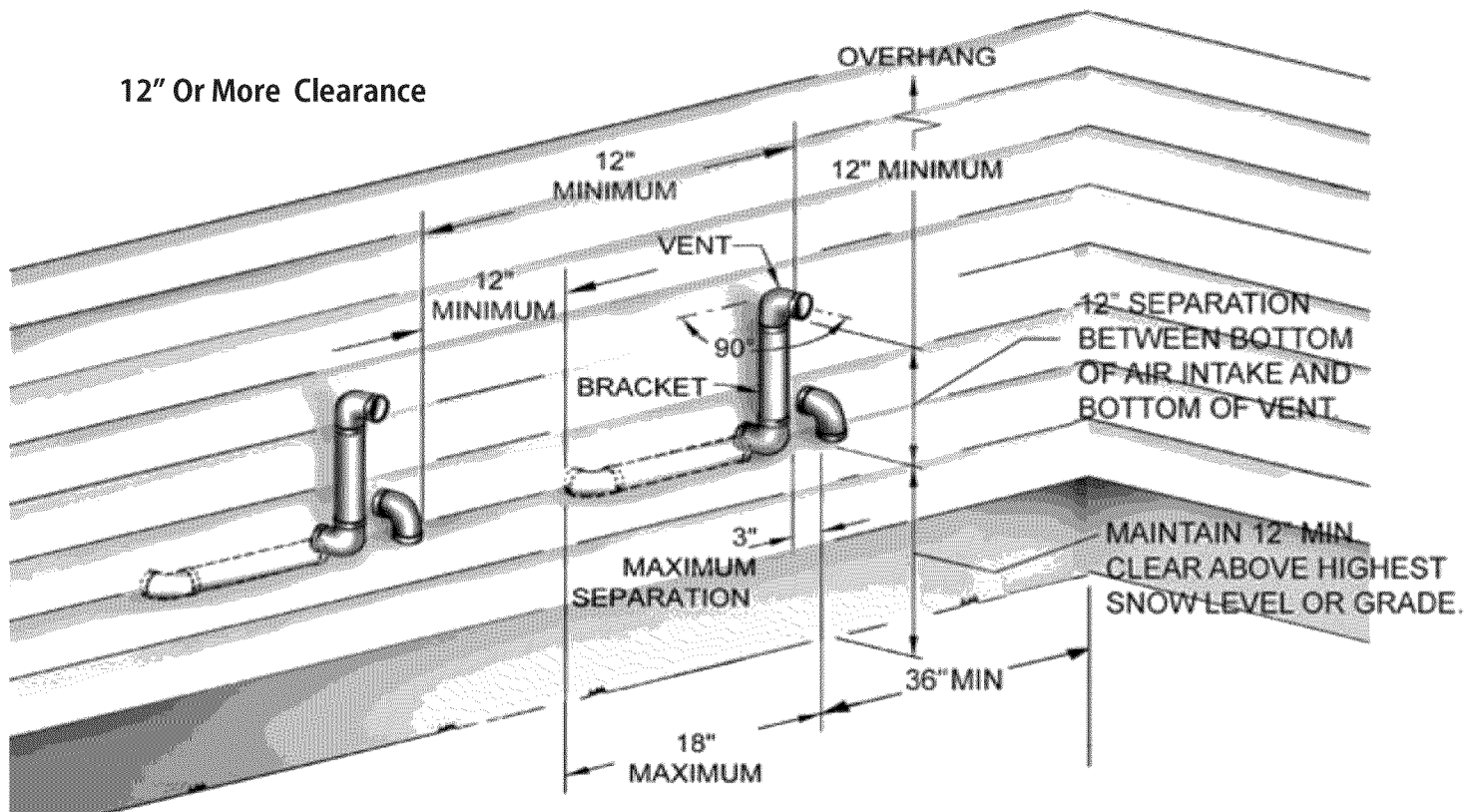
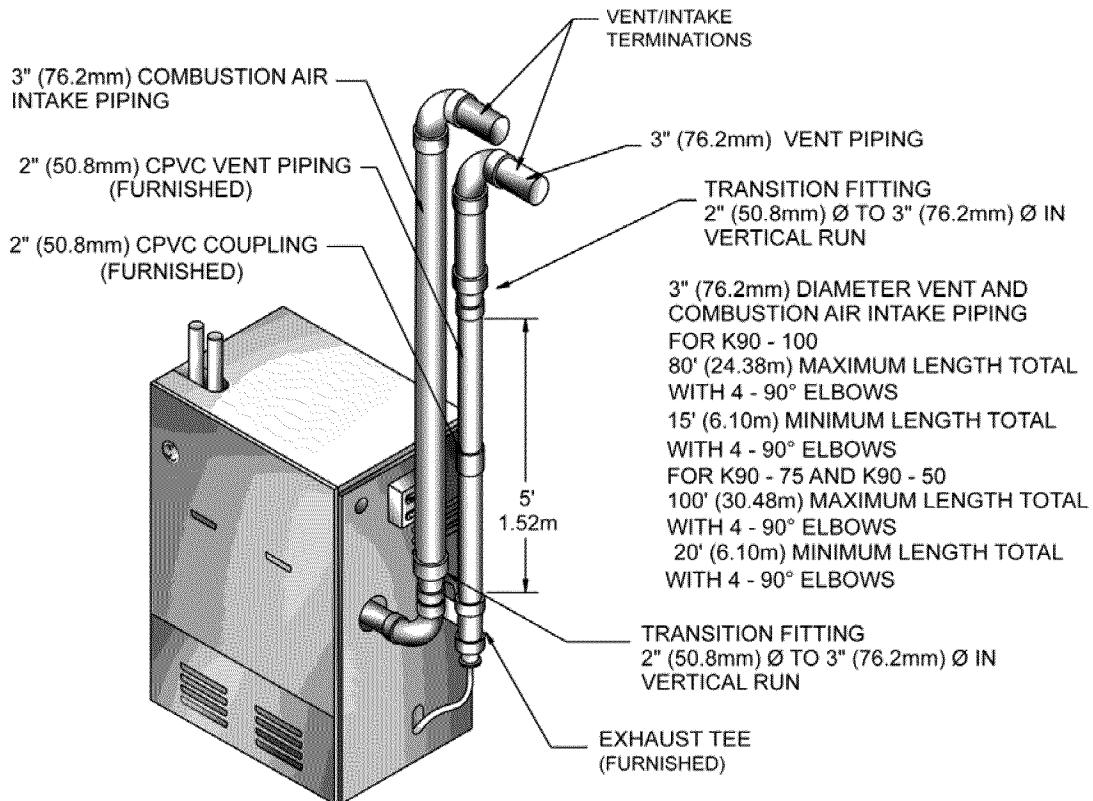
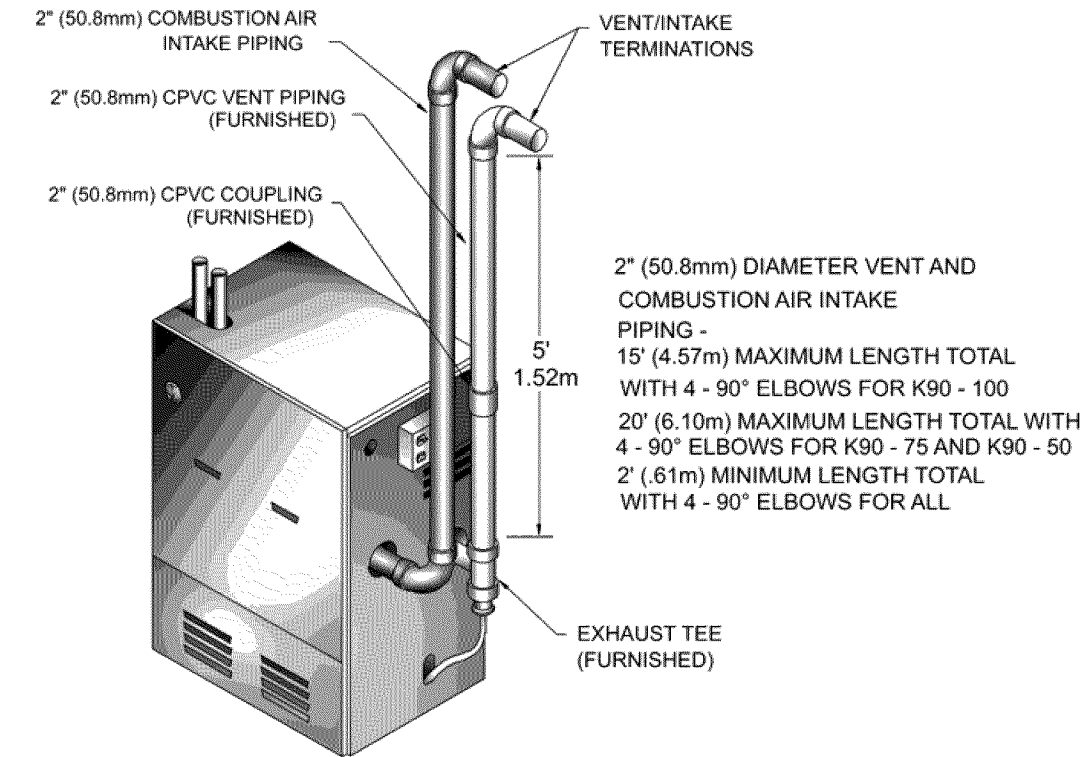

Figure 11 - Combustion Air and Vent Piping



Installation

1. Attach combustion air intake piping to supplied Fernco 2" coupling on mixer. Attach vent piping to furnished 2" CPVC vent tee on draft inducer outlet.

NOTICE

All pipe joints are to be water tight

2. Working from the boiler to the outside, cut pipe to required length(s).
3. Deburr inside and outside of pipe.
4. Chamfer outside edge of pipe for better distribution of primer and cement.
5. Clean and dry all surfaces to be joined.
6. Check dry fit of pipe and mark insertion depth on pipe.

NOTICE

It is recommended that all pipes be cut, prepared, and pre-assembled before permanently cementing any joint.

7. After pipes have been cut and pre-assembled, apply cement primer to pipe fitting socket and end of pipe to insertion mark. Quickly apply approved cement to end of pipe and fitting socket (over primer). Apply cement in light, uniform coat on the inside of socket to prevent buildup of excess cement. Apply second coat.
8. While cement is still wet, insert pipe into socket with ¼ turn twist. Be sure pipe is fully inserted into fitting socket.
9. Wipe excess cement from joint. A continuous bead of cement will be visible around perimeter of a properly made joint.
10. Handle pipe joint carefully until cement sets.
11. Support combustion air and vent piping a minimum of every 5 feet using pre-formed metal hanging straps. Do not rigidly support pipes. Allow movement due to expansion and contraction.
12. Slope horizontal portion of combustion air and vent pipes toward boiler a minimum of ¼" per linear ft. (21mm/m) with no sags between hangers.
13. Use appropriate methods to seal openings where vent and combustion air pipes pass through roof or side wall.

GAS SUPPLY PIPING

Check Gas Supply

The gas pipe to your boiler must be the correct size for the length of run and for the total Btu per hour input of all gas utilization equipment connected to it. See **Table #3** for the proper size (next page). Be sure your gas line complies with local codes and gas company requirements.

The boiler and its individual shutoff valve must be disconnected from the gas supply piping system during any pressure testing of that system at test pressures in excess of ½ psig (3.5kpa).

The boiler must be isolated from the gas supply piping system by closing its individual manual shutoff valve during any pressure testing of the gas supply piping system at test pressures equal to or less than ½ psig (3.50ka).

	NATURAL GAS	PROPANE GAS
MAXIMUM GAS SUPPLY PRESSURE	10" w.c.	14" w.c.
MINIMUM GAS SUPPLY PRESSURE	4" w.c.	10" w.c.

Connecting The Gas Piping

Refer to **Figure 12** (on following page) for the general layout at the boiler. It shows the basic fittings you will need. The gas line enters the boiler from the right side jacket panel. The boiler may receive the gas supply pipe through the left side, or rear jacket panel by relocating the gas valve connector and pipe assembly. The boiler is equipped with a ½" NPT connection on the gas valve for supply piping. The following rules apply:

1. Use only those piping materials and joining methods listed as acceptable by the authority having jurisdiction, or in the absence of such requirements, by the National Fuel Gas Code, ANSI Z223.1/NFPA 54 and or the Natural Gas and Propane Installation Code, CAN/CSA B149.1.
2. Use pipe joint compound suitable for liquefied petroleum gas on male threads only.
3. Use ground joint unions.
4. Install a sediment trap upstream of gas controls.
5. Use two pipe wrenches when making the connection to the gas valve to keep it from turning.
6. Install a manual shutoff valve in the vertical pipe about 5 feet above floor.
7. Tighten all joints securely.
8. Propane gas connections should only be made by a licensed propane installer.
9. Two stage regulation should be used by the propane installer.
10. Propane gas piping should be checked out by the propane installer.

Checking The Gas Piping

The boiler and its gas connection must be leak tested before placing the boiler in operation. Open the manual shutoff valve. Test for leaks by applying soap suds (or a liquid detergent) to each joint. Bubbles forming indicate leak. CORRECT EVEN THE SMALLEST LEAK AT ONCE.



WARNING

Never use a match or open flame to test for leaks.

TABLE #3 – GAS PIPE SIZES				
NATURAL GAS				
Length of Pipe - Ft.	Pipe Capacity - BTU Per Hour Input Includes Fittings			
	1/2"	3/4"	1"	1 1/4"
20	92,000	190,000	350,000	625,000
40	63,000	130,000	245,000	445,000
60	50,000	105,000	195,000	365,000
PROPANE GAS				
Length of Pipe - Ft.	Pipe Capacity - BTU Per Hour Input Includes Fittings			
	Copper Tubing*		Iron Pipe	
	5/8"	3/4"	1/2"	3/4"
20	131,000	216,000	189,000	393,000
40	90,000	145,000	129,000	267,000
60	72,000	121,000	103,000	217,000

* Outside diameter

Figure 12 - Gas Piping

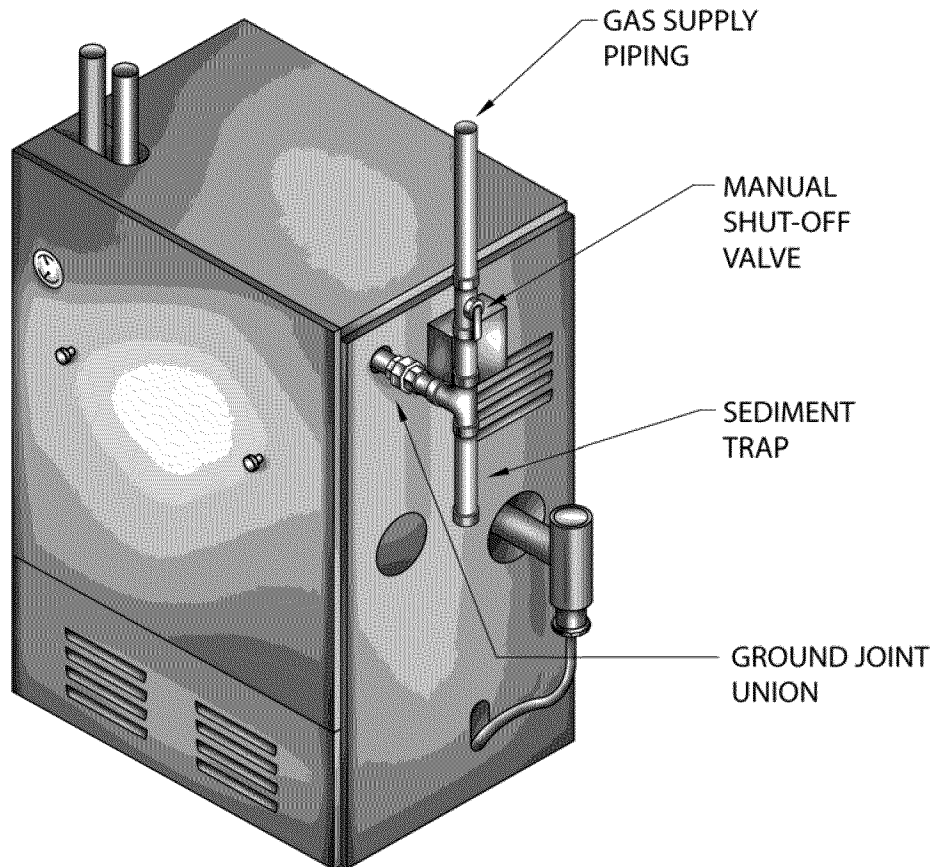

WARNING



Turn off electrical power at fuse box before making any line voltage connections. Follow local electrical codes.

All electrical work must conform to local codes as well as the National Electrical Code, ANSI/NFPA70, and/or the Canadian Electrical Code, Part 1, CSA C22.1, Electrical Code.

Electric Power Supply

Prior to making any line Voltage connections, service switch at boiler should be in the OFF position and the power turned OFF at the fuse box.

Run a separate 120 Volt circuit from a separate over current protection device in the electrical service entrance panel. This should be a 15 ampere circuit. A service switch has been pre-wired and located on the exterior boiler jacket. See **Figure 13** for diagram showing location of service switch junction box and power supply connection points. Connect black (hot) lead from the power supply to either of the unused brass screws on the service switch. Connect the white (neutral) lead from the power supply to the white screw on the service switch. Connect the green (ground) lead from the power supply to the ground (green) screw on the service switch. The receptacle on the service switch is always powered regardless of whether the switch is ON or OFF, and could be used as a power supply for an external condensate pump if one is used.

The boiler, when installed, must be electrically grounded in accordance with the requirements of the authority having jurisdiction or, in the absence of such requirements, with the National Electrical Code, ANSI/NFPA-70 and/or the Canadian Electrical Code Part 1, CSA-C22.1, Electrical Code.

Run a 14 gauge or heavier copper wire from the boiler to a grounded connection in the service panel or a properly driven and electrically

Install Your Thermostat

The thermostat location has an important effect on the operation of your boiler system. **BE SURE TO FOLLOW THE INSTRUCTIONS INCLUDED WITH YOUR THERMOSTAT.**

Locate the thermostat about five feet above the floor on an inside wall. It may be mounted directly on the wall or on a vertical mounted outlet box. It should be sensing average room temperature.

Avoid the Following:

Set heat anticipator at 0.7 amps. Connect 24 Volt thermostat leads to the two(2) yellow wires located in service switch junction box, located on outer jacket of boiler. See **Figure 13** for service switch junction box and thermostat field wiring connections.

Connect Circulator Pump Wiring

See **Figure 13** (following page) for service switch junction box and circulator pump field wiring connections. A 5 feet wiring harness with flexible metal conduit is supplied to connect the circulator pump to the service switch junction box. If the two 120 Volt circulator wire terminals inside the junction box are not used, please leave the two wire nuts to prevent the short circuit.

CAUTION



LABEL ALL WIRES PRIOR TO DISCONNECTION WHEN SERVICING CONTROLS. WIRING ERRORS CAN CAUSE IMPROPER AND DANGEROUS OPERATION. VERIFY PROPER OPERATION AFTER SERVICING.

Things to Avoid when Locating Thermostats	
DEAD SPOTS:	
Corners and alcoves	Behind doors
COLD SPOTS:	
Concealed pipes or ducts	Concealed pipes
	Fireplace
Stairwells - drafts	TV sets
	Radios
Unheated rooms on other side of wall	Lamps
	Direct sunlight
	Kitchens

Figure 13 - Field Wiring Connections

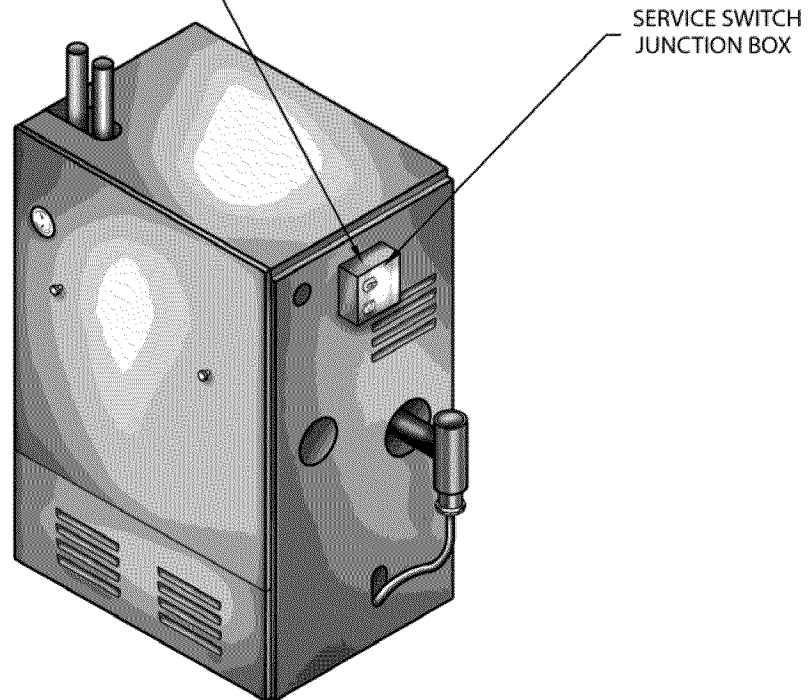
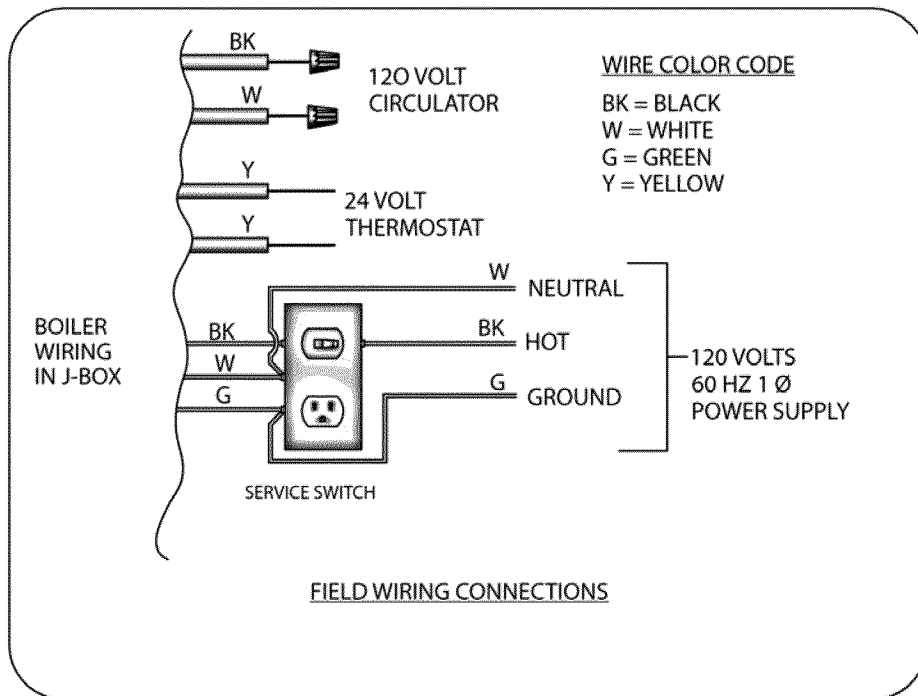
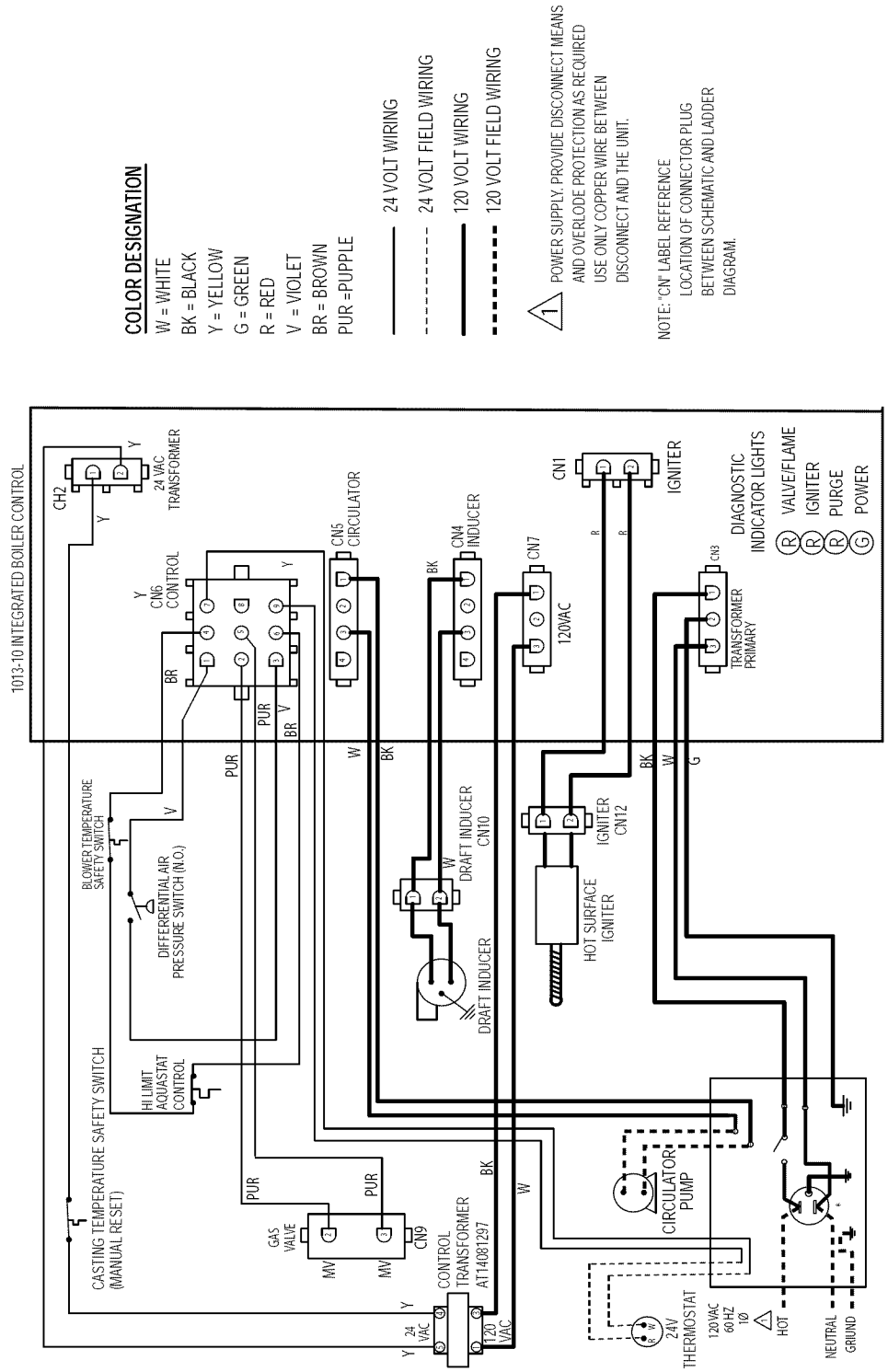
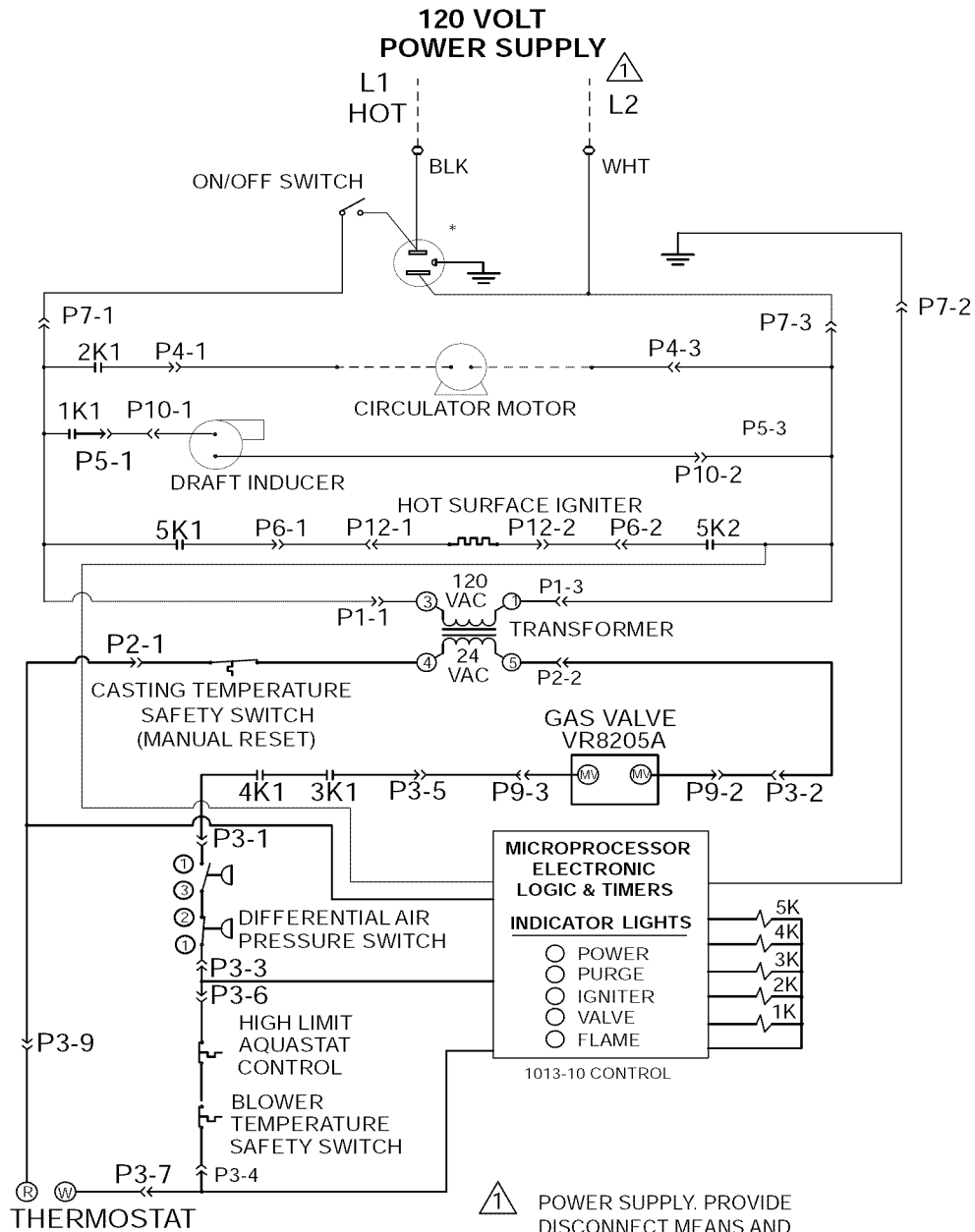

Figure 14 - D - Schematic Wiring Diagram



If any of the original wire as supplied with this appliance must be replaced, it must be replaced with type 150° C Thermoplastic wire or its equivalent

Figure 15 - E - Ladder Wiring Diagram



NOTE: "P" LABEL REFERENCE LOCATION OF CONNECTOR PLUG BETWEEN SCHEMATIC AND LADDER DIAGRAM

* CAUTION: RECEPTACLE IS LIVE WHEN BOILER SWITCH IS OFF

→ REFERENCES PLUG CONNECTION

This section provides a brief description of the key controls and accessories found in this boiler.

See the Troubleshooting section (page 47 of the of this installation manual) for detailed sequences of operation and troubleshooting procedures. See the Repair Parts Manual for locations of all control components and accessories described.

Integrated Boiler Control (IBC)

The Integrated Boiler Control (IBC) is a microprocessor based controller for a high efficiency gas boiler that monitors all safety controls and which controls the operation of the combustion air blower, circulator pump, burner, and a combination hot surface igniter/flame sensor. This controller is not intended for use with a vent damper. This controller is mounted on the control panel inside of the boiler and contains five (5) diagnostic indicator lights.

Gas Control Valve

The electrically controlled 24 Volt Honeywell Model VR8205 Combination Gas Control Valve is designed to meet the requirements for use with hot surface ignition systems found in this boiler. The valve is piped to the gas/air mixer.

Hot Surface Igniter

The 120 Volt Hot Surface Igniter heats up to 1800 °F to initiate combustion of the gas in the burner. The igniter is mounted next to the burner through the gas/air mixer. The igniter also serves as a means for proving the main burner flame by flame rectification. In the event of a lack of flame signal on three (3) consecutive trials for ignition, the IBC will lockout. The “VALVE” and “FLAME” diagnostic indicator lamps (lamp “D” and “E” on the IBC, See **Figure 16**) will blink indicating the failure mode as a lack of flame signal. The IBC is manually reset from lockout by either removing and reestablishing the thermostat’s call for heat, or by turning the service switch OFF, then back ON.

High Limit Aquastat Control

The High Limit Aquastat Control determines the maximum boiler water temperature and also provides a means for protecting the boiler and heating system from unsafe operating conditions which could damage the boiler. The aquastat is mounted in the ½” NPT control well and ¾”x½” bushing on the top of the front boiler section at the hot water outlet. The aquastat is tied in with the IBC and is factory set at 180 °F water temperature. The high limit setpoint is field adjustable and may be set anywhere between 100 °F and 200 °F. The field setpoint adjustment for each installation depends on heating system requirements. The aquastat automatically resets when the boiler water temperature decreases (5-30 °F adjustable differential). The differential can be adjusted with the (white) Differential Adjustment Wheel on the aquastat and gives the flexibility for boiler operation. The larger the differential, the longer the run cycle of the boiler.

NOTICE

The maximum setpoint of the Aquastat must not exceed 200 °F.

Draft Inducer Temperature Safety Switch

The Draft Inducer Temperature Safety Switch is a disc thermostat (180 °F setpoint) located on the induced draft fan outlet port. The switch protects the inducer and vent pipe from a potential high temperature condition for the discharging flue gases. This condition would typically be a result of higher aquastat setting or over firing. The temperature safety switch automatically resets when the higher aquastat setting or over firing. The temperature safety switch automatically resets when the vent temperature decreases. (15 °F switch differential).

Casting Temperature Safety Switch

In the event of lack of or loss of water in the boiler, the Casting Temperature Safety Switch (300 °F setpoint) installed on the top of the aluminum boiler section shuts off the boiler by shutting off power to the Integrated Boiler Control (IBC) and causes the Power Indicator Light to go out. This fault requires manual reset of the casting temperature safety switch to restart the boiler. Verify that the boiler is properly filled with water before resetting this switch.

WARNING-Never run cold water into a hot empty boiler.

Differential Pressure Air Proving Switch/Blocked Vent Safety Shutoff

All 90 Series Hot Water Boilers come equipped with either one (100 Series) or two (200 Series) diaphragm-type differential pressure switches. The differential pressure switch monitors air flow by sensing the differential pressure measured in inches of water (“w.c.”). The pressure switch contacts close when the draft inducer is running. The closed switch proves there is adequate air flow for combustion. The pressure switch shuts off the main burner if the differential pressure is inadequate due to a blocked vent pipe, a blocked air intake, blocked boiler sections, or a blocked draft inducer. After five (5) minutes of lack of adequate differential pressure, the IBC will lock out and the “Purge” indicator light will blink, indicating a failure to prove adequate combustion air flow or flue gas flow. The IBC will be automatically reset after fifteen (15) minutes or can be manually reset from lockout by (a) removing and reestablishing the thermostat call for heat or (b) by turning the service switch OFF and back ON again. If the boiler cannot be restored to normal operating conditions by resetting the control, contact a qualified service agency to check the heat exchanger flue-ways for blockage.

Draft Inducer

The draft inducer (blower) provides a means for pulling combustion air into and through the mixer, the burner, the flue ways of the cast aluminum boiler sections and the flue adapter before being discharged through the vent piping to the outdoors. See applicable sections for proper sizing and installation of combustion air and vent piping in this manual.

Circulator Pump

Every forced hot water system requires at least one circulating pump. The circulating pump imparts the necessary energy to move the water through the closed loop supply and return piping systems, terminal heating equipment (i.e. finned tube radiators, etc.) and back through the boiler for reheating. To provide the required hot water flow rates, the circulator pump must be properly sized to overcome frictional losses (usually measured in feet of water, also referred to as “pump head loss”) of the supply and return piping systems and boiler. The circulator pump is furnished in a carton within the boiler cabinet for a single zone or zone valve controlled heating system and should be correctly located on the downstream (i.e., pumping away) side of the expansion tank. For a pump controlled system (where there is a circulator for each zone) the circulator provided with the boiler can work for one zone. For more details on piping and circulators, see Near Boiler Piping section (page 12 of this manual).

Drain Valve

The manual drain valve provides a means of draining the water in the heating system, including the boiler and hot water supply and return piping systems installed above the drain valve. This drain valve is installed in the $\frac{3}{4}$ " tapping at the bottom of the front boiler section. Any piping installed below the elevation of this drain valve will require additional drain valves to be installed at low points in the piping systems in order to drain the entire system.

A.S.M.E. Rated Pressure Relief Valve

Each boiler must have a properly sized and installed American Society of Mechanical Engineers rated pressure relief valve. Water expands as it is heated by the burner/boiler sections. If there is no place for the water to expand its volume, (i.e. a properly sized and properly functioning expansion tank) pressure on the inside of the boiler and heating system will increase. The furnished relief valve will automatically open at 30 psig pressure to relieve the strain on the boiler and heating system from the increasing pressure. The pressure relief valve discharge must be piped with piping same size as the valve discharge opening to an open drain, tub or sink, or other suitable drainage point not subject to freezing, in accordance with A.S.M.E. specifications. Failure to provide the pressure relief valve with piping as herein described may cause water damage and/or serious bodily injury. The boiler manufacturer is not responsible for any water damage or personal injury.

Blocked Vent Safety Shutoff

This boiler is equipped with a blocked vent safety shutoff means, which shuts off main burner gas in the event that the flow of combustion products through the flueways is reduced. In the event of blocked flueways, enough air will not be available to support combustion, and the S9301 Integrated Boiler Control (IBC) will lockout due to loss of adequate air flow (after 3 trials for ignition). The “PURGE” diagnostic indicator lamp (lamp “B” on the IBC, see **Figure 16**) will blink indicating the failure mode as a lack of adequate air flow. The IBC is manually reset from lockout by either removing and re-establishing the thermostat’s call for heat, or by turning the service switch OFF, then back ON. If the boiler cannot be restored to normal operating condition by resetting the control, contact a qualified service agency to check heat exchanger flueways for blockage.

External Condensate Pump (Optional)

For installations where there is no floor drain or other appropriate drainage receptacle available to receive condensate from the boiler, an external float activated condensate pump with integral sump is required. This unit can be installed to pump the condensate to a remote tie in point to a sanitary sewer system. For this application, the boiler must be installed so that proper pitch of piping to the external condensate reservoir (sump) can be accomplished. Use wood frame or blocks to raise boiler as required for proper installation.

When filling the boiler water is the preferred heating solution. Most potable water supplies may be used to charge and re-fill provided the chlorine and chloride ions levels are less than 100 ppm.

Antifreeze may be used in most applications provided all of the following conditions are met:

1. Unless a strict schedule of sampling, analysis and maintenance of the antifreeze solution is followed, the boiler must be piped as a primary loop connected to secondary loop as shown in the Piping & Wiring Diagram Appendix. Failure to perform regular maintenance to the antifreeze manufacturer's instructions will result in damage to the heat exchanger and the voiding of boiler warranty.
2. Only the antifreeze manufacturers listed below are selected.
3. At installation of a new or replacement boiler and at least on an annual basis the system antifreeze must be analyzed by the antifreeze supplier or their recommended laboratory.
4. Adjustments to the system antifreeze must be made according to the antifreeze manufacturers recommendations using only their recommended products.
5. All existing systems MUST be flushed of ALL old system fluid. Failure to do so may void the boiler warranty if evidence of improper flushing is revealed. Consult with your heating professional for recommendations.

Piping Recommendations

System leaks may not always be visible. An unseen system leak will become obvious if boiler pressure decreases when make up valve is closed.

All system leaks must be repaired immediately. Constant introduction of make up water will introduce dissolved oxygen, resulting in accelerated boiler corrosion.

It is recommended that Primary/Secondary piping be used with any of the recommended antifreeze solutions found in this manual. See the **Piping & Wiring Diagram Appendix**.

Water Chemistry

This boiler is designed for a closed loop hydronic heat system ONLY! This boiler is not suitable for natural gravity type installations, or any other open type system.

System fluid pH must be maintained between 7.0 and 8.0.

Maintain water hardness below 7 grains hardness.

Filling with chlorinated fresh water should be acceptable since drinking water chlorine levels are typically less than 5 ppm. Do not fill boiler with water containing chlorine and chloride ions levels greater than 100 ppm.

Do not use inhibitors or other additives that are not specifically approved by the antifreeze manufacturer for this product.

Consult the antifreeze manufacturer if any of the above are outside the stated ranges.

Cleaning the Hydronic System

IMPORTANT: Do not mix different manufacturers' products. Doing so will void the warranty of the boiler.

Consideration MUST be given to cleaning the heating system, particularly in retrofit situations where a new boiler with an aluminum heat exchanger is being installed in an existing piping system.

All existing systems must be cleaned and flushed according to the antifreeze manufacturer's recommendations.

Systems that have antifreeze that is not recommended by the boiler manufacturer must be completely flushed to ensure no unapproved antifreeze remains according to the recommended antifreeze manufactures recommendations. Evidence of an alternate antifreeze in the system may void the boiler warranty.

In older systems obviously discolored, murky or dirty water; or a pH reading outside the boiler manufacturer's stated acceptable range (pH 7.0 to 8.0) are indications that the system should be cleaned or treated.

1. Measure total capacity of the system including the piping, tanks, boiler, collector plates, etc. The most accurate method of measuring fluid capacity is to fill the system and then completely drain it, volumetrically measuring the fluid drained.
2. Thoroughly flush the system with clean water to remove any sediment or contaminants. Sludge and iron oxide deposits can cause rapid breakdown of inhibitors.
3. Cleaning fluid – Flushing with clean water is preferred. If cleaning fluid is used, only use cleaner specifically approved for use with aluminum boilers. Use only cleaning fluids and the procedure recommended by the antifreeze manufacturer.

Freeze Protection

Aluminum Safe Antifreeze, Treatments and Additive Guidelines:

Antifreeze, if required, must be one of the antifreeze manufacturers listed in this manual. See the "Recommended Aluminum Antifreeze & Inhibitor Suppliers" section of this manual for a list of boiler manufacturer approved products.

Always clean system prior to using antifreeze, refer to the Cleaning the Hydronic System section of this manual for details.

Only use the antifreeze manufacturers' products outlined in this document.

Use of antifreeze must be in accordance with local plumbing codes. Dispose of old antifreeze and boiler system water in accordance with local authorities.

Antifreeze will raise the pH of the hydronic solution in a heating system above the recommended level due to the corrosion inhibitors in the antifreeze. The solution must be treated to maintain a pH within the boiler manufacturer's recommended level to avoid damage to the heat exchanger. Follow antifreeze manufacturer's instructions for details on how to adjust the pH.

WATER TREATMENT & FREEZE PROTECTION

If the system has leaked for some reason, the water and antifreeze chemistry will need to be adjusted. To avoid damage to the boiler, check the pH and chemistry of the boiler solution and consult the antifreeze manufacturer for recommendations.

It is recommended that a pH reading is taken annually, and adjusted as necessary. Follow antifreeze / inhibitor manufacturer's instructions for details on how to adjust the pH.

- Use of antifreeze in any boiler will reduce heating capacity as much as 10-20%. This must be taken into consideration when sizing the heating system, pumps and expansion tank. Consult antifreeze manufacturer's literature for specific information on reduced capacity.
- Using the antifreeze manufacturer's instructions to determine the

freezing temperature needed and use the correct amount of antifreeze. Never exceed 50% antifreeze by volume.

- The boiler operating pressure must remain below 15 psi for antifreeze solutions that specify a maximum of 250 °F (121 °C).

NOTICE

Antifreeze solutions can breakdown over time. Failure to check antifreeze chemistry, including inhibitors, annually may result in accelerated corrosion of boiler and other system components. Consult with the antifreeze manufacturer for recommendations.

Recommended Aluminum Antifreeze & Inhibitor Suppliers	Recommended Products
Interstate Chemical 2797 Freedland Road P.O. Box 1600 Hermitage, PA 16148-0600 www.interstatechemical.com Tel: 800-422-2436 Fax: 724-981-8383	Intercool NFP-30,40,50 AA Intercool RPH-15*
Noble Company PO Box 350 Grand Haven, MI 49417 www.noblecompany.com Tel: 800-878-5788 Fax: 800-272-1519	Noburst AL Antifreeze
Rhomar Water Management, Inc. PO Box 229 Springfield, MO 65801 www.rhomarwater.com Tel: 800-543-5975 Fax: 417-862-6410	Rhogard Antifreeze Pro-Tek 922 Inhibitor*

* These products may be used to adjust the pH level of the hydronic system, but on occasion may not resolve the pH issue. In these cases it is recommended to flush the system and refill with untreated water and new boiler manufacturer approved antifreeze suitable for Aluminum heat exchangers.

IMPORTANT: Regardless of antifreeze or inhibitors used, be sure to follow the antifreeze manufacturer's instructions for use, safe handling and storage of their products. Refer to the MSDS (Material Safety Data Sheets) provided by the antifreeze manufacturer for potential hazards and first aid procedures for exposure or ingestion.

Antifreeze Testing Services: Each of the recommended antifreeze manufacturers have developed a sampling program available to the homeowner and contractor. Contact the antifreeze manufacturer regarding their sampling plan procedure. Consult the antifreeze manufacturer for details on sample requirements and recommendations.

The boiler manufacturer reserves the right to make changes without notice.

Filling Boiler With Water And Purging Air For Systems With Diaphragm Type Expansion Tanks

Refer to the appropriate diagrams in Section VII, “Near Boiler Piping,” for more information.

1. Close all zone service valves on the supply and return piping. Open the feed valve and fill boiler with water. Make sure air vent is open. Hold relief valve open until water runs air free for five seconds to rapidly bleed air from boiler, then let the relief valve snap shut.
2. Open the zone service valve on the supply pipe for the first zone. Open the purge valve on the first zone. Feed water will fill the zone, pushing air out the purge valve. Close the purge valve when the water runs air free. Close the zone service valve.
3. Repeat step 2 for all remaining zones.
4. Open all service valves. Any air remaining trapped in the return lines between the service valves and the boiler will be pushed towards the air vent when the boiler is placed in operation.
5. Inspect piping system. Repair any leaks immediately.

Purging Air For Systems With Conventional Closed Type Expansion Tanks:

Refer to the appropriate diagrams in Section VII, “Near Boiler Piping,” for more information.

1. Close all zone service valves on the supply and return piping and close the expansion tank service valve. Drain expansion tank. Open the feed valve and fill boiler with water. Hold relief valve open until water runs air free for five seconds to rapidly bleed air from boiler, then let the relief valve snap shut.
2. Open the zone service valve on the supply pipe for the first zone. Open the purge valve on the first zone. Feed water will fill the zone, pushing air out the purge valve. Close the purge valve when the water runs air free. Close the zone service valve.
3. Repeat step 2 for all remaining zones.
4. Open the expansion tank service valve and the tank vent. Fill the tank to the proper level and close the tank vent. Remove the handle from the expansion tank service valve so the homeowner doesn't accidentally close it.
5. Open all service valves. Any air remaining trapped in the return lines between the service valves and the boiler will be pushed towards the expansion tank when the boiler is placed in operation.
6. Inspect piping system. Repair any leaks immediately.

Placing Boiler In Operation

WARNING



If you do not follow these instructions exactly, a fire or explosion may result causing property damage, personal injury or loss of life.

- A. This appliance is equipped with an ignition device which automatically lights the pilot. Do not try to light the pilot by hand.
- B. BEFORE OPERATING smell all around the appliance area for gas. Be sure to smell next to the floor because some gas is heavier than air and will settle on the floor.

What To Do If You Smell Gas

- Do not try to light any appliance.
 - Do not touch any electrical switch; do not use any phone in your building.
 - Immediately call your gas supplier from a neighbor's phone. Follow the gas supplier's instructions.
 - If you cannot reach your gas supplier, call the fire department.
- C. Use only your hand to move the system control switch. Never use tools. If the switch will not move by hand, don't try to repair it, call a qualified service technician. Force or attempted repair may result in a fire or explosion.
 - D. Do not use this appliance if any part has been under water. Immediately call a qualified service technician to inspect the appliance and to replace any part of the control system and any gas control which has been under water.

NOTICE

DO NOT use stop leak compounds. Leaks in threaded connections in the aluminum boiler sections must be repaired immediately. Aluminum threads will not seal themselves.

OPERATING INSTRUCTIONS

1. STOP! Read the safety information above on this label.
2. Set thermostat to lowest setting.
3. Turn off all electric power to the appliance.
4. This appliance is equipped with an ignition device which automatically lights the burner. DO NOT try to light the burner by hand.
5. Remove the front jacket panel.
6. Turn the gas control knob clockwise ↻ to "OFF".
7. Wait five (5) minutes to clear out any gas. Then smell for gas, including near the floor. If you smell gas, STOP! Follow "B" in the safety information above on this label. If you don't smell gas go on to next step.
8. Turn the gas control knob counterclockwise ↻ to "ON".
9. Replace front jacket panel.
10. Turn on all electrical power to the appliance.
11. Set the thermostat to desired setting.
12. If the appliance will not operate, follow the instructions "To Turn Off Gas To Appliance" and call your service technician or gas supplier.

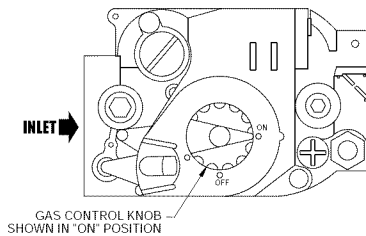

TO TURN OFF GAS TO APPLIANCE

1. Set the thermostat to lowest setting.
2. Turn off all electric power to the appliance if service is to be performed.
3. Remove the front jacket panel.
4. Turn gas control knob clockwise ↻ to "OFF".
5. Replace the front jacket panel.

Safe lighting and other performance criteria were met with the gas manifold and control assembly provided on the boiler when the boiler underwent tests specified in ANSI Z21.13-latest revision.

Verify Proper Sequence Of Operation

The sequence can be followed via the diagnostic indicator lamps on the Honeywell S9301A integrated boiler control in **Figure #16**. This is the normal sequence of operation. A more detailed sequence of operation containing potential faults can be found in the service hints section.

Figure 16 - Indicator Lamps

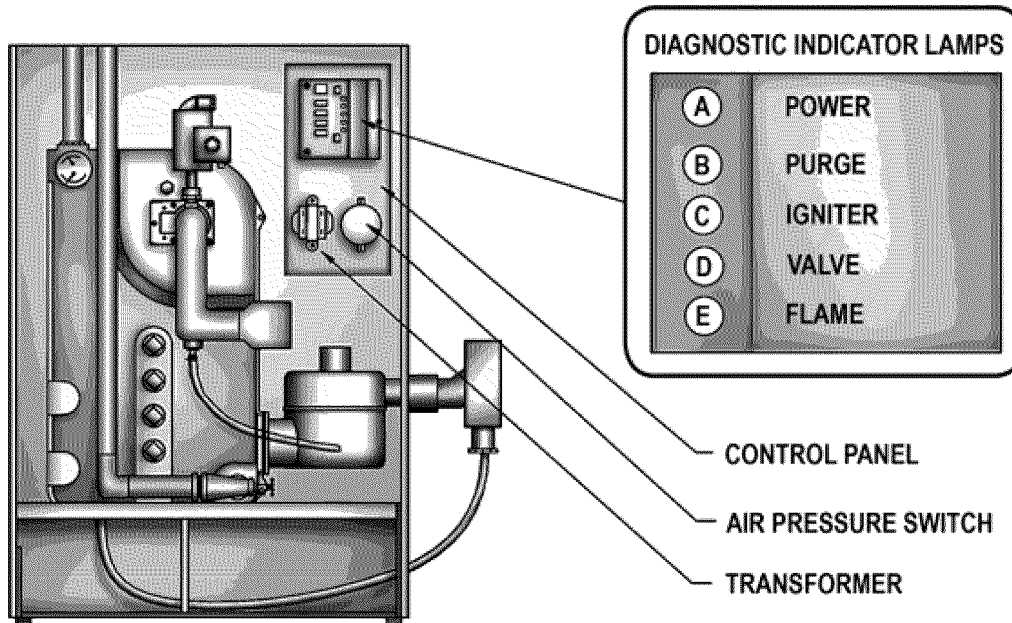

SEQUENCE OF OPERATION	"DIAGNOSTIC INDICATOR LAMPS"
"Power ON, boiler standing by. Lamp A is illuminated indicating 2 Volt power is being supplied to the integrated control."	A. ● B. ○ C. ○ D. ○ E. ○
Thermostat calls for heat, energizing system circulator	A. ● B. ○ C. ○ D. ○ E. ○
"Integrated boiler control goes through self check of internal circuitry (1-2 seconds) and energizes draft inducer"	A. ● B. ○ C. ○ D. ○ E. ○
"Draft inducer comes up to speed and establishes combustion airflow, causing the normally open differential pressure air proving switch contacts to close. Lamp B is illuminated indicating that combustion airflow is proved and the 15 second pre purge cycle"	A. ● B. ● C. ○ D. ○ E. ○

SEQUENCE OF OPERATION	"DIAGNOSTIC INDICATOR LAMPS"
After pre purge, Lamp B goes out and Lamp C illuminates, indicating the hot surface igniter is powered for the 20 second igniter warm-up period. The bright yellow orange glow of the hot surface igniter can be observed through the observation port in the front boiler section just above the igniter.	A. ○ B. ○ C. ● D. ○ E. ○
After igniter warm-up, the gas valve is energized, and opens on the normal firing rate regulator (2.5" w.c.) for a 6 second trial for ignition. Lamp D illuminates. The blue orange glow of the burner can be seen through the observation port.	A. ● B. ○ C. ● D. ● E. ⊙
Two seconds later, Lamp C goes out as power is turned off to the hot surface igniter. During the last two seconds of the 6 seconds trial for ignition, main burner flames is proven by flame rectification through the hot surface igniter, providing flame rectification to the integrated boiler control and fully illuminating Lamp E. The gas valve remains energized, and the boiler runs.	A. ● B. ○ C. ○ D. ● E. ●
Thermostat ends call for heat, de-energizing gas valve and system circulator. Burner stops firing, and Lamp D goes out. Draft inducers remains powered. Lamp B illuminates, indicating draft inducer is running for 30 second post-purge.	A. ● B. ● C. ○ D. ○ E. ○
After 30 seconds, draft inducer is de-energized. Lamp B goes out. Boiler stands by for next call for heat.	A. ● B. ○ C. ○ D. ○ E. ○

NOTICE

First couple of cold starts may be rough due to gas line not being completely purged of air, causing low firing rate and high excess air levels.

Inspect Venting And Air Intake System

Operate the boiler and verify that all vent/air intake connections are gas-tight and watertight. Repair any leaks immediately.

Inspect Condensate Drain

Verify that all connections are watertight, and that condensate flows freely. Repair any leaks immediately.

Inspect System Piping

Verify that all connections are watertight. Repair any leaks immediately.

Test Ignition System Safety Shutoff Device

1. Turn off manual gas valve
2. Set thermostat to call for heat
3. Boiler begins normal sequence of operation
4. After approximately 40 seconds (pre purge and igniter warm-up period), lamp D illuminates, indicating gas valve is powered
5. After 6 seconds, gas valve closes, lamp D goes out as integrated boiler control senses that flame is not present
6. To restart system, follow operating instructions under "START-UP PLACE IN OPERATION"

Test High Limit Control And Adjust

While burner is operating, move indicator on high limit control below actual boiler water temperature. Burner should go off while circulator continues to operate. Raise limit setting above boiler water temperature and burner should reignite after pre purge and igniter warm-up period. Set the high limit control to the design temperature requirements of the system. Maximum high limit setting is 200°F. Minimum high limit setting is 100°F.

Test Other Safety Controls

If the boiler is equipped with a low water cut off, a manual reset high limit, or additional safety controls, test for operation as outlined by the control manufacturer. Burner should be operating and should go off when controls are tested. When safety controls are restored, burner should reignite.

Set Thermostat Heat Anticipator (If Used) And Verify Thermostat Operation

For a single thermostat connected to the yellow thermostat lead wires in the furnished field wiring junction box, the heat anticipator should be set at 0.7 amps. For other wiring configurations, refer to the instructions provided by the thermostat manufacturer regarding adjustment of heat anticipator. Cycle boiler with thermostat. Raise the thermostat to the highest setting and verify boiler goes through normal start up cycle. Lower thermostat to lowest setting and verify boiler goes off.

Measure The Natural Gas Input Rate

Correct input rate is essential for proper and efficient operation of the burner and boiler.

1. Determine elevation at installation site.
2. See page 6 and 7 of this manual to determine the correct input rate for the local elevation.
3. Obtain the yearly average heating value of the local gas supply from the gas utility. At sea level elevation, it should be approximately 1000 Btu's per standard cubic foot.
4. Operate boiler for 5 minutes.
5. Turn off all other gas appliances, extinguishing standing pilots where applicable.
6. At gas meter, measure time in seconds required to use one cubic foot of gas.
7. Calculate input rate according to the following formula:

$$\text{Btuh input rate} = \frac{3600 \times \text{heating value from step 3}}{\text{time from step 6}}$$
8. Measured input rate should be within +/-2% of the input rating from step 2. If within 2%, go to step 9. If not, adjustment is required, proceed as follows:
 - A. Turn boiler off

- B. Set up U-tube manometer or differential pressure gauge for measuring manifold pressure, see **Figure #17**.
 - C. Manometer or gauge must be able to read at least 0.0 to 3.0 inches water column of pressure, and resolve to at least 0.1 inches water column.
 - D. Turn boiler on.
 - E. Manifold pressure has been nominally set at 2.5 inches w.c. Manifold pressure and input rate must always be measured with pressure regulator cover screw installed. Cover screw must be removed for adjustment. Manifold pressure reading will change (increase) when cover screw is removed.
 - F. After adjusting input rate, turn boiler off, remove manometer or pressure gauge, reinstall 1/8" plug on gas valve. Turn boiler on.
9. Restore all gas appliances that may have been shut off (while measuring boiler input rate) to normal operating conditions.
 - I. Remove regulator cover screw on top of gas valve, and insert an appropriate screwdriver into adjustment screw.
 - II. Turn adjustment screw clockwise to increase input rate, or counter clockwise to decrease input rate.
 - III. Replace cover screw, or cover hole temporarily with your finger to check new manifold pressure setting. Do not set manifold pressure lower than 2.0 inches w.c. or higher than 3.0 inches w.c. when adjusting input rate.
 - IV. Measure new input rate (cover screw must be installed). Repeat steps I-IV until the input rate is within +/-2% of the nameplate input rating.
 - V. If the actual input rate can not be set to within 2% of the correct input rating by adjusting manifold pressure, a change in gas orifice size is required. Consult the boiler manufacturer for information on correct orifice sizing. The specific gravity (G) and the higher heating value (HHV) of the local natural gas must be obtained from the local gas utility in order to determine the proper orifice size.

Set Thermostat To Desired Room Temperature

Observe several operating cycles to verify proper operation.

Review All Instructions

Review all instructions shipped with this boiler with owner or maintenance person. Instructions must be affixed on or adjacent to the boiler.

Complete and sign the installation and check-out certificate found in this manual.

CHECK OUT PROCEDURE AND ADJUSTMENT

The following steps and diagram indicate the location of the connection points required to measure the manifold pressure.

The manifold pressure may be measured using a U-Tube Manometer or a Differential Pressure Gauge. The diagram shows the connection of both measuring devices. Only ONE DEVICE IS REQUIRED to measure the manifold pressure.

Remove the plug. Install the appropriate barbed fitting and connect the pressure side line from the U-Tube Manometer or Differential Pressure Gauge.

Refer to "CHECK OUT PROCEDURE AND ADJUSTMENTS" in this manual when reading the manifold pressure.

When measurement is completed, disconnect the U-Tube Manometer or Differential Pressure Gauge. Be sure to reinstall the 1/8" plug, using appropriate pipe thread sealant approved for use with natural and liquefied Petroleum gases.

Figure 17 - Manifold Pressure Measurement Detail

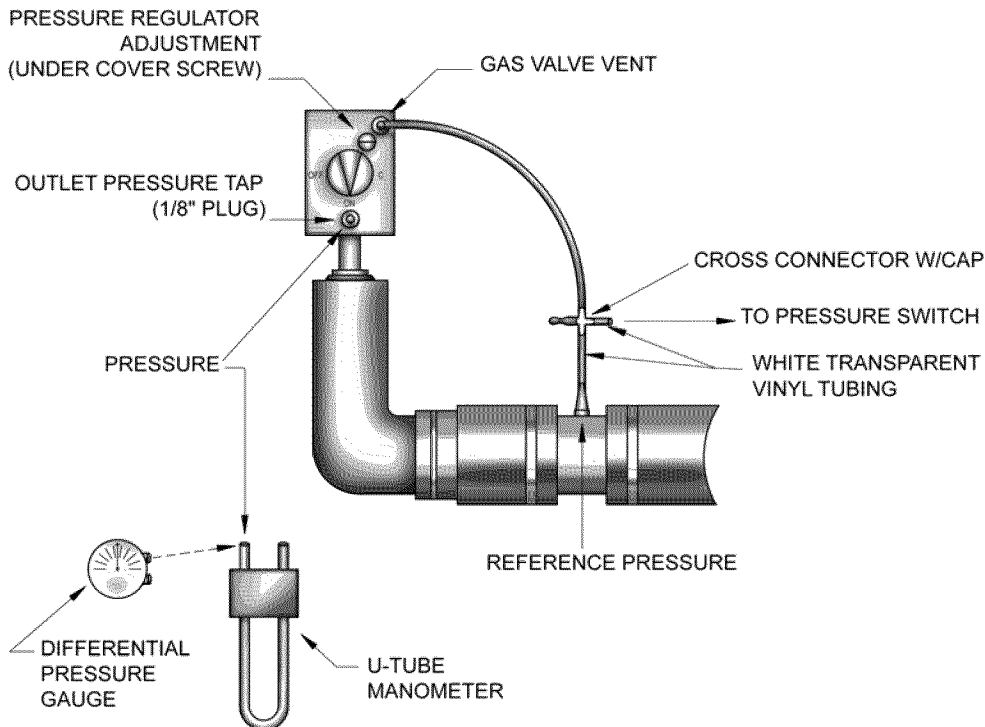
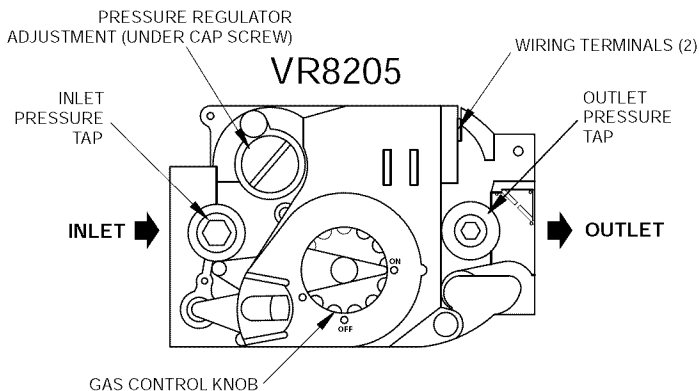

Figure 18 - Gas Valve



NOTICE

Regulator cover screw must be installed at all times unless adjusting manifold pressure. Firing rate and manifold pressure must only be measured with cover screw firmly installed.

INSTALLATION AND CHECK-OUT CERTIFICATE

Boiler Model _____ Serial # _____ Date Installed _____

Measured BTU/HR input _____

- Installation instructions have been followed
- Checkout procedure and adjustments performed
- Maintenance and Service issues reviewed with owner/ maintenance person
- Installation booklet affixed on or adjacent to boiler

Installer (Company)

Address

Phone

Installer's Name

Signature

Maintenance as outlined below can be performed by the owner unless otherwise noted.

The acidic nature of flue gasses condensing on the aluminum boiler sections will cause the formation of aluminum oxide. This oxide formation is normal, is generally uniform throughout the boiler sections, and represents a negligible mass of aluminum that is consumed by oxidation during the life of the boiler. If left unchecked, this buildup may eventually cause blockage of the flue gas passages in the boiler sections, reducing efficiency, and ultimately shutting down the boiler due to lack of combustion air flow. Regular service and maintenance by a qualified service agency must be performed to assure safe trouble free operation and maximum efficiency.

Beginning Of Each Heating Season

1. Annual service call by a qualified service agency, which includes:
 - A. Examine flue passages between boiler sections, burner, and condensate lines, and clean if necessary following the annual examination and cleaning instructions in paragraph "F" on the next page.
 - B. Visually inspect venting and air intake system for proper function, deterioration or leakage. If the vent or air intake show any signs of deterioration or leakage, repair or replace them, immediately. Insure proper reassembly and resealing of the vent and air intake system
 - C. Check for and remove any obstruction to the flow of combustion air or venting of flue gases. Check the air baffle located inside 1½" x 2" flexible coupling on the mixer, clean it if necessary and make sure to put it back. Refer to repair parts diagram of mixer and pressure switch assembly for exact location.
 - D. Follow instructions for "PLACING BOILER IN OPERATION".
 - E. Follow instructions for "CHECK OUT PROCEDURE AND ADJUSTMENTS".
 - F. Visually inspect condensate drain line for proper operation and deterioration. Check for plugged condensate drain line.
 - G. Check the silicone rubber seals between boiler sections. Insure that there are no leaks. Use RTV silicone rubber adhesive sealant (available in caulking gun tubes) rated for at least 400° F to replace or repair seals in locations where original seals have deteriorated.
 - H. Check all gasketed joints for leakage, and tighten bolts or replace gaskets if necessary.
 - I. Remove jacket front and top panels and check for piping leaks around relief valve and other fittings. Repair, if found. DO NOT use stop leak compounds.

2. Check that boiler area is free from combustible materials, gasoline, and other flammable vapors and liquids.
3. Circulator pump and blower motor furnished with boiler are permanently lubricated from factory and require no further lubrication. Additional or non-factory supplied pumps and/or motors should be lubricated according to the pump and/or motor manufacturer's instruction.

Daily During Heating Season

1. Check for and remove any obstruction to the flow of combustion air or venting of flue gases.
2. Check that boiler area is free from combustible materials, gasoline, and other flammable vapors and liquids.

NOTICE

The following service procedures must be performed only by a qualified service agency. Boiler owner should not attempt these procedures.

Monthly During Heating Season

1. 1. Remove jacket front and top panels and check for piping leaks around relief valve and other fittings. If found, contact a qualified service agency to repair. DO NOT use stop leak compounds.
2. 2. Test relief valve. Refer to valve manufacturers instructions packaged with relief valve.
3. 3. Visually inspect venting and air intake system for proper function, deterioration, or leakage. If the vent or air intake show any signs of deterioration or leakage, contact a qualified service agency to repair or replace them immediately and to insure proper reassembly and resealing of the vent and air intake system.
4. 4. Visually inspect the clear vinyl condensate lines and the PVC condensate drain pipe for proper operation, leakage, and deterioration. If the condensate lines or drain pipe show any signs of blockage, leakage, or deterioration contact a qualified service agency to clean, repair, or replace them immediately.
5. 5. Check the air baffle located inside 1 ½" x 2" flexible coupling, clean it if necessary and make sure to put it back. Refer to repair parts diagram, mixer and pressure switch assembly.

Periodically During Heating Season

Where low water cut offs are used, a periodic inspection of the low water cut off is necessary, including flushing of float type devices. Refer to low water cut off manufacturer's specific instructions.

End of Each Heating Season - Annual Shutdown Procedure

Follow instructions "TO TURN OFF GAS TO APPLIANCE".

If heating system is to remain out of service during freezing weather, and does not contain antifreeze, drain system completely. If boiler will be exposed to freezing temperatures, drain condensate lines. Otherwise, do not drain system or boiler.

Annual Examination And Cleaning Of Boiler Components

1. Before Servicing, turn off electrical power to boiler at service switch. Close manual gas valve to turn off gas supply to boiler.

2. Cleaning Flue passages between boiler sections.
 - A. Any buildup of sediment or aluminum oxide (white powdery or flaky substance) in the flue passages must be cleaned as follows:
 - B. Remove jacket front and top panels. Disconnect condensate drain line from the barbed fitting on the bottom of the boiler. Keep the open end of the drain line above the water level in the condensate trap to prevent the trap from draining. Disconnect pressure switch hose from barbed fitting on gas valve. Disconnect 1½ x 2" flexible coupling from air inlet. Disconnect air by-pass (½" transparent vinyl tube) from the bottom of the mixer.
 - C. Remove air baffle from ½" x 2" flexible coupling and clean air baffle if necessary. Refer to repair parts diagram, mixer and pressure switch assembly.
 - D. Confirm that manual gas valve is closed and disconnect gas line to gas valve at union. Disconnect wires to gas valve and igniter.
 - E. Loosen but do not remove five (5) nuts attaching mixer assembly to boiler. Remove two (2) igniter screws and very carefully remove the igniter. Use care when removing the igniter, it is very brittle!
 - F. Remove five (5) nuts and remove mixer assembly. Remove burner and mixer gasket.
 - G. Aluminum oxide deposits are water soluble and may be rinsed away with spraying or running water. Before rinsing, connect a ½" I.D. hose to the barbed fitting on the bottom of the boiler and run the hose to a bucket or drain.
 - H. After rinsing, remove any remaining loosened sediment using a shop vacuum with a snorkel attachment.
 - I. Inspect burner for any foreign matter in the flame ports or inside the burner. Any foreign matter should be removed by blowing with compressed air or vacuuming.
 - J. Inspect interior of mixer for any signs of sediment or aluminum oxide and clean if necessary.

- K. Reinstall burner and mixer gasket and position mixer assembly over studs. Install five (5) nuts but do not tighten. Reinstall igniter and igniter gasket and fasten with two (2) screws. Use care when installing the igniter. It is very brittle! Tighten five (5) nuts holding mixer assembly.
- L. Connect:
 - Gas line to gas valve
 - Condensate drain line to boiler
 - Pressure switch hose to gas valve
 - Air by-pass to mixer
 - 1 ½" x 2" flexible coupling to air inlet and make sure to put air baffle back to correct position
 - Igniter wires
 - Gas valve wires
- 3. Visually inspect condensate lines leading from the boiler sections and the vent tee to the condensate trap. Refer to repair parts diagrams. Any foreign material or debris that is visible in the condensate lines needs to be cleaned out as follows:
 - A. Raise condensate trap and drain condensate lines completely.
 - B. Once the condensate trap is emptied of water, disconnect condensate lines from the fittings on the boiler, the vent tee, and the condensate outlet.
 - C. Remove the condensate trap and run cold water through the condensate lines to thoroughly flush out any sediment or debris in the lines.
 - D. Reinstall and connect the condensate trap, using the hose clamps to secure the various condensate lines to their fittings.
 - E. Follow the instructions under "NEAR BOILER PIPING" for "filling condensate trap with water"
- 4. Inspection of the flue connector requires the following steps (Refer to the repair parts diagram.)
 - A. Loosen the clamp on the draft inducer end of the 2" flexible coupling that connects the vent tee to the draft inducer. Disconnect (unplug) wiring harness from draft inducer motor and draft inducer temperature safety switch. Remove four (4) bolts that attach draft inducer to flue connector.
 - B. Remove draft inducer and gasket from top of flue connector.
 - C. Inspect interior of flue connector. Any buildup of sediment or aluminum oxide on the inside surface must be cleaned. Position the draft inducer gasket and the draft inducer and fasten with four (4) screws. Be sure to connect ground wire from draft inducer motor to one of the four mounting screws.
 - D. Connect wiring harness leads to the draft inducer motor and the draft inducer temperature safety switch.
 - E. Connect the 2" flexible coupling to the draft inducer outlet.

Service Hints

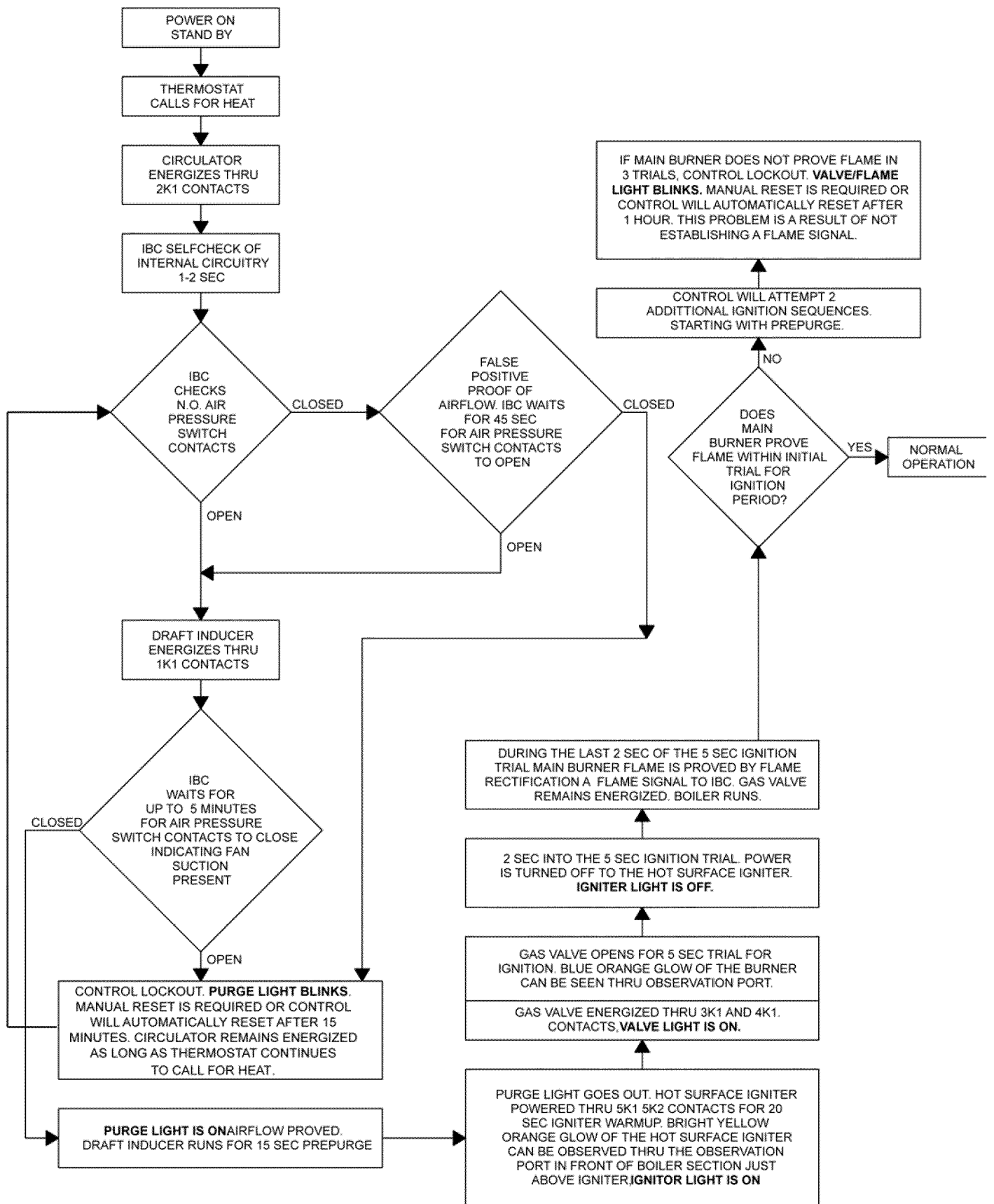

DRAFT INDUCER TEMPERATURE SAFETY SWITCH

IF DRAFT INDUCER TEMPERATURE REACHES TEMPERATURE SAFETY SWITCH SETPOINT, SAFETY SWITCH CONTACTS OPEN IMMEDIATELY CLOSING GAS VALVE (LIGHT GOES OUT)

Draft Inducer Runs Thru 30 Second Post Purge And Switches Off.

CIRCULATOR RUNS WITH THERMOSTAT ON CALL FOR HEAT.

WHEN TEMPERATURE SAFETY SWITCH CONTACTS REMAKE BEFORE END OF CALL FOR HEAT, CONTROL GOES INTO NORMAL SEQUENCE.

CASTING TEMPERATURE SAFETY SWITCH

IF BURNER OPERATES WHEN BOILER HAS NO WATER, ALUMINUM BOILER SECTIONS HEAT UP RAPIDLY.

CASTING TEMPERATURE SAFETY SWITCH CONTACTS WILL OPEN BREAKING 24 VOLT POWER TO IBC. POWER INDICATOR LIGHT GOES OUT. REQUIRES MANUAL RESET TO RE-CLOSE CONTACTS. POWER LIGHT GOES OUT.

LOSS OF FLAME SIGNAL

IF AN ESTABLISHED FLAME SIGNAL IS LOST WHILE CONTROL EXPECTS THAT THE BURNER IS OPERATING, CONTROL WILL IMMEDIATELY DE-ENERGIZE GAS VALVE. **VALVE AND FLAME LIGHTS GO OUT.**

DRAFT INDUCER RUNS THROUGH 30 SECOND POST PURGE.

CONTROL WILL ATTEMPT TO RELIGHT BOILER 3 TIMES. IF FLAME IS NOT PROVEN, CONTROL LOCKOUT - PROBLEM ESTABLISHING A FLAME SIGNAL. **VALVE LIGHT IS BLINKING.** CONTROL WILL AUTOMATICALLY RESET AFTER 1 HOUR.

HIGH LIMIT CONTROL

IF BOILER WATER TEMPERATURE REACHES HI LIMIT (AQUASTAT) SETPOINT, HI LIMIT N.C. CONTACTS OPEN IMMEDIATELY, CLOSING GAS VALVE. VALVE AND FLAME LIGHTS GO OUT.

DRAFT INDUCER CONTINUES TO RUN FOR 30 SECONDS POST PURGE AND SWITCH OFF.

CIRCULATOR RUNS AS LONG AS THERMOSTAT CALLS FOR HEAT.

WHEN HI LIMIT CONTACTS REMAKE BEFORE END OF CALL FOR HEAT, CONTROL GOES INTO A NORMAL LIGHT OFF SEQUENCE.

LOSS OF COMBUSTION AIRFLOW

IF COMBUSTION AIRFLOW IS LOST WHILE BURNER IS FIRING (DIFFERENTIAL AIR PRESSURE SWITCH CONTACTS OPEN) GAS VALVE WILL BE DE-ENERGIZED. **VALVE AND FLAME LIGHTS GO OUT.**

DRAFT INDUCER RUNS THROUGH 30 SECOND POST PURGE.

IF CALL FOR HEAT REMAINS, IBC WAITS 5 MINUTES FOR AIRFLOW TO BE RE-ESTABLISHED.

IF AIRFLOW DOES NOT RE-ESTABLISH CONTROL LOCKOUT - PROBLEM WITH COMBUSTION AIRFLOW. **PURGE LIGHT BLINKS.** CONTROL WILL AUTOMATICALLY RESET AFTER 15 MINUTES.

CIRCULATOR PUMP

CIRCULATOR WILL BE ENERGIZED AS LONG AS THERMOSTAT CALLS FOR HEAT DURING LOCKOUT.

RECOVERY FROM ANY LOCKOUT REQUIRES RESET, WHICH CAN BE ACCOMPLISHED BY:
(A) REMOVING AND REESTABLISHING THE THERMOSTAT'S CALL FOR HEAT OR TURNING THE SERVICE SWITCH OFF AND BACK ON;
OR (B) WAITING FOR THE CONTROL TO AUTOMATICALLY RESET AFTER 15 MINUTES FOR LOSS OF COMBUSTION AIRFLOW OR ONE HOUR FOR LOSS OF FLAME.

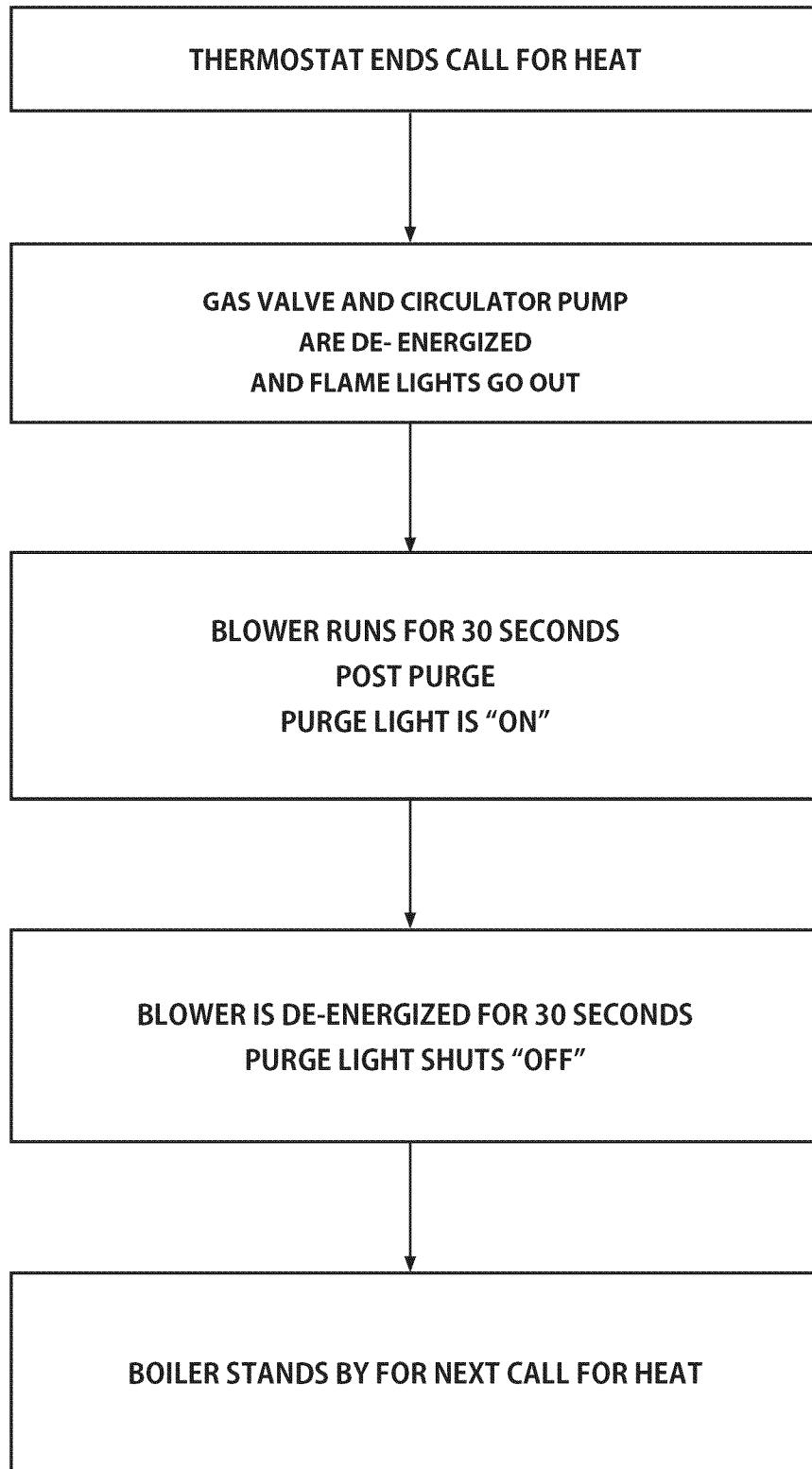

WARNING

Fire, explosion or shock hazard may cause property damage, severe injury or death. Do not attempt to modify the physical or electrical characteristics of this boiler in any way.

Important

1. In a reset from lockout condition, all electrical meter readings at the gas control valve (24 vac) must be taken within the trial for ignition period.
 2. If any component does not function properly, make sure it is correctly installed and wired before replacing it.
 3. Static electricity discharge can damage the integrated boiler control (IBC). Touch metal surface to discharge static electricity before touching IBC.
 4. The IBC cannot be repaired. If it malfunctions it must be replaced.
 5. Only trained, experienced service technicians should service the IBC systems. Following troubleshooting, check out the system following the sequence of operation section of this chapter for a normal light off sequence.
 6. All controls are factory tested in the assembly process and a defective control is generally the least likely cause. If you suspect you have a defective control, read through the troubleshooting chart before you replace it.
 7. It is extremely unlikely that the two consecutive controls are defective. If it seems to be happening, chances are that either there is nothing wrong with the control or it is being damaged by some other problem (an electrical short burning out a transformer, for example).
2. Troubleshooting tools:
 - A. Voltmeter to check 120 vac and 24 vac
 - B. Continuity tester.
 - C. Inclined manometer or pressure gauge with 0-2.0" Range (0.01" Scale) for measuring suction pressures at pressure switch.
 - D. U-tube manometer or differential pressure gauge with 0-14" range (0.1" Scale) for measuring inlet and manifold gas pressures.
 3. What is system status?
 - A. Consult the chart on the following page.
 - B. **Figure #16** shows the location on the boiler of the diagnostic indicator lamps.

Initial Service Checks

1. Before troubleshooting:
 - A. Make sure that circuit breaker is on or fuse is ok at electrical panel.
 - B. Make sure that service switch is on.
 - C. Make sure that gas is on at the gas meter, at all appropriate manual shutoff valves and at the gas control valve.
 - D. Make sure that the thermostat is calling for heat.
 - E. Check that wire connectors at the integrated boiler control and at the originating control are securely plugged in or connected.
 - F. Check that hoses are securely connected and are not plugged in or damaged.

System Status

The indicator lights track the operating sequence. If the system locks out, the lights indicate the point in the sequence of operation where lockout occurs.

LIGHT	STATUS	INDICATES
POWER	ON	IBC IS ENERGIZED THROUGH 24 VOLT TRANSFORMER.
	OFF	IBC IS NOT ENERGIZED.
	BLINKING	IBC RECEIVES MORE THAN 40 VAC
PURGE	ON	IBC IS ENERGIZING THE DRAFT INDUCER AND AIR FLOW IS PROVEN.
	OFF	OFF DURING PURGE CYCLE-DRAFT INDUCER IS NOT POWERED OR AIR FLOW IS NOT PROVEN.
		OFF DURING IGNITER AND RUN CYCLE-NORMAL OPERATION, PURGE CYCLE COMPLETE.
BLINKING	IBC IS LOCKED OUT. PROBLEM COULD INDICATE FALSE POSITIVE PROOF OF AIR FLOW. BLOCKED VENT OR INTAKE AIR PIPE OR FLUE WAY.	
IGNITER	ON	IBC IS ENERGIZING IGNITER
	OFF	IGNITER IS NOT ENERGIZED
VALVE	ON	IBC IS ENERGIZING GAS CONTROL VALVE TO OPEN.
	OFF	GAS CONTROL VALVE IS CLOSED.
	BLINKING	IBC IS LOCKED OUT. PROBLEM IS FLAME HAS NOT BEEN PROVEN IN THREE (3) IGNITION ATTEMPTS. MAY BE DUE TO BROKEN IGNITER OR LACK OF OR LOW FLAME SIGNAL, OR NO GAS.
FLAME	ON	FLAME PROVEN
	OFF	FLAME UNPROVEN

TROUBLESHOOTING CHART 1

WARNING

Electrical shock hazard may cause Serious injury or death.

The following procedures may expose you to dangerous line voltage. Use caution to avoid touching live electrical contacts. Service must be performed by a trained, experienced service technician.

What to do if you smell gas:

Do not try to light any appliance

Do not touch any electrical switch; do not use any phone in your building.

Immediately call your gas supplier from a neighbor's phone. Follow the gas supplier's instruction.

If you can not reach your gas supplier, call the fire department.

Should overheating occur or the gas supply fail to shut off, do not turn off or disconnect the electrical supply to the pump. Instead, shut off the gas at a location external to the appliance.

Do not use the boiler if any part of the gas control system has been under water a qualified service technician should inspect the boiler and replace any part of the control system and any gas control which has been under water.

Use only your hand to turn the gas control knob. Never use tools. If the knob will not turn by hand. Don't try to repair it. Force or attempted repair may result in a fire or explosion.

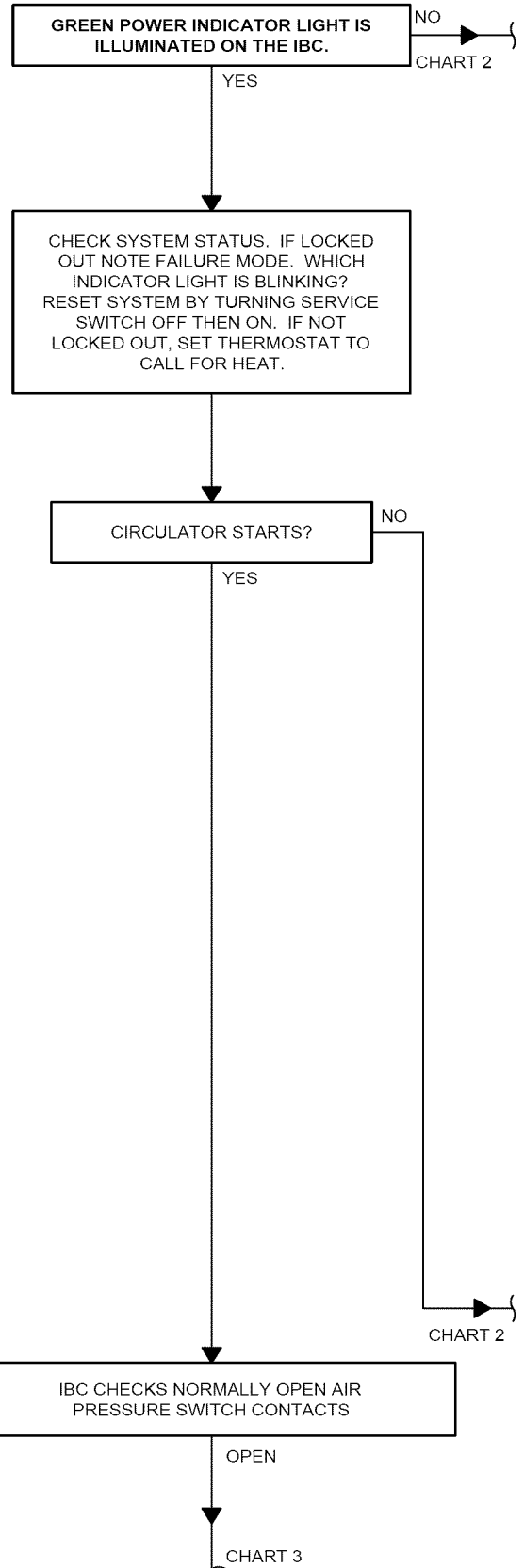

FALSE POSITIVE PROOF OF AIRFLOW. CHECK AIR PRESSURE SWITCH CONTACTS. IF CONTACTS ARE CLOSED WITH NO AIRFLOW, REPLACE PRESSURE SWITCH.

TROUBLESHOOTING CHART 2

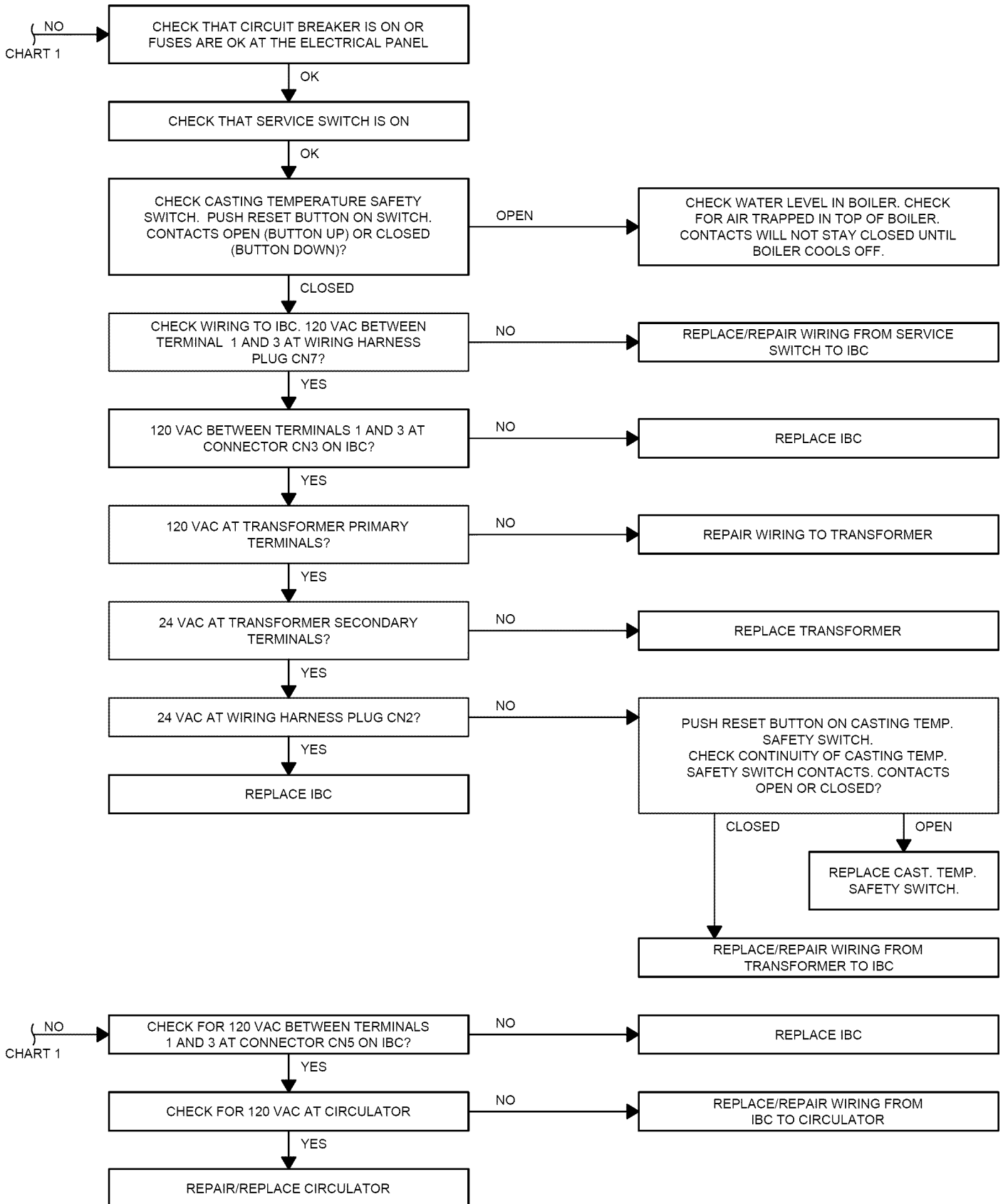

TROUBLESHOOTING CHART 3

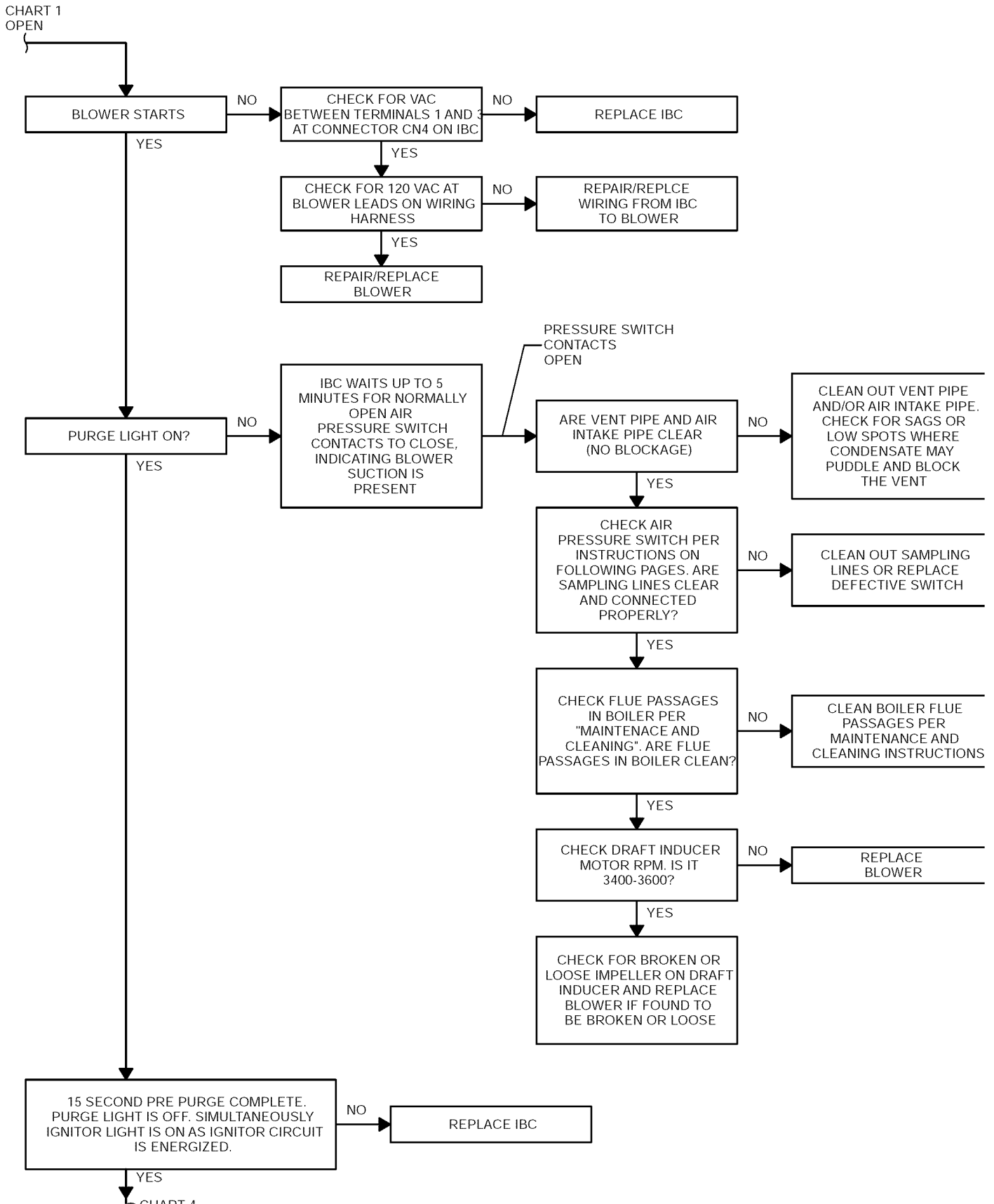

TROUBLESHOOTING CHART 4

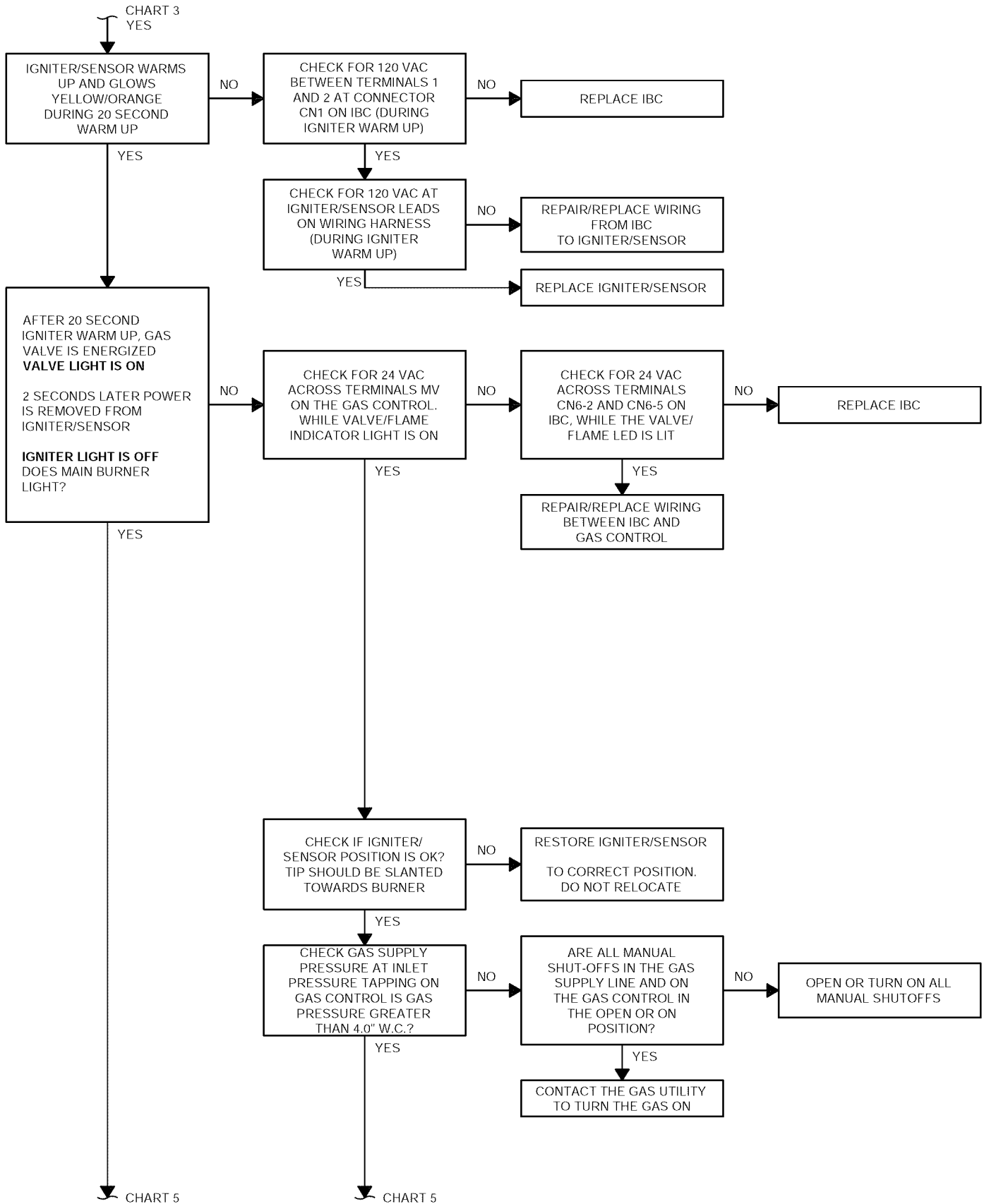

TROUBLESHOOTING CHART 5

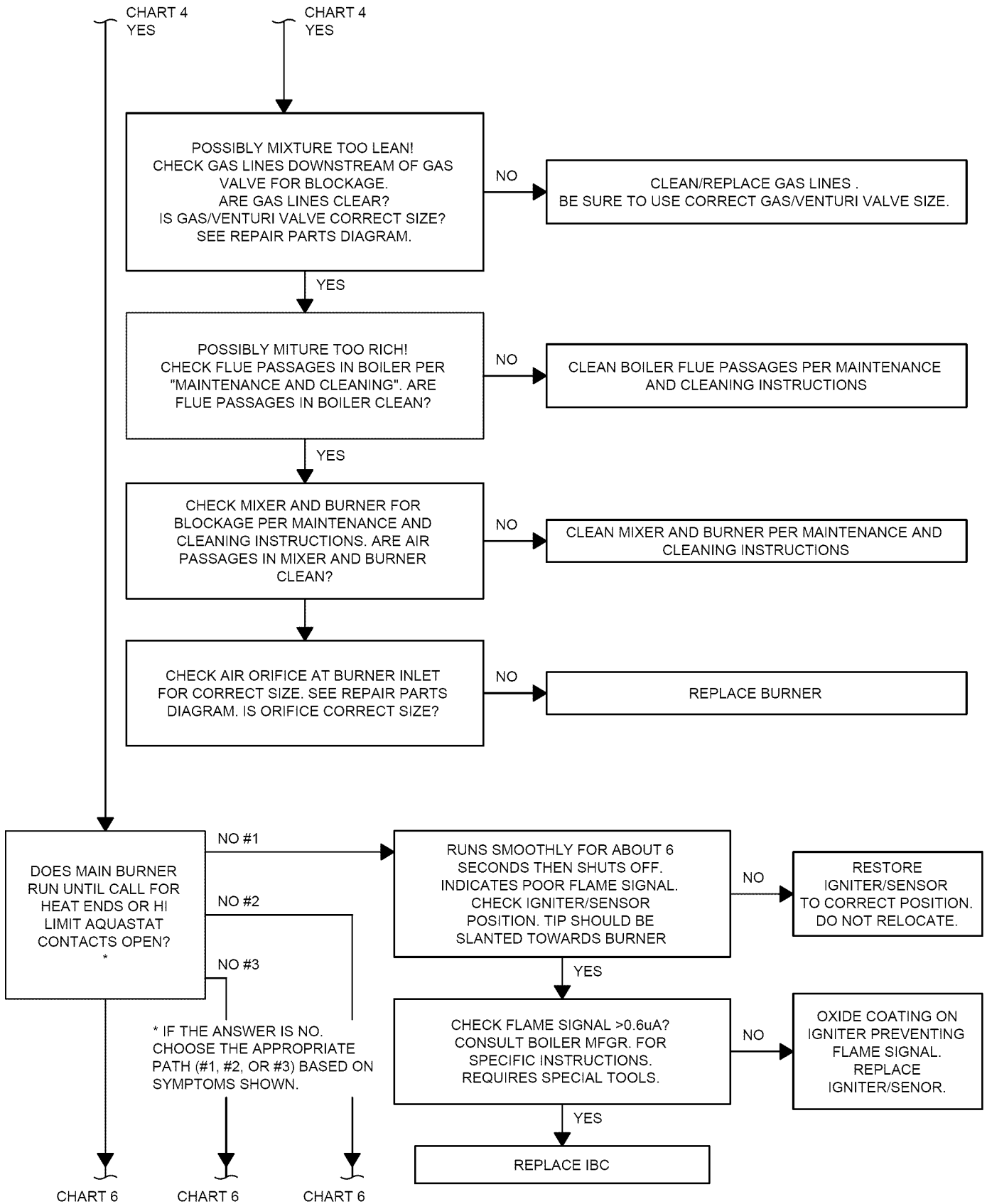

TROUBLESHOOTING CHART 6

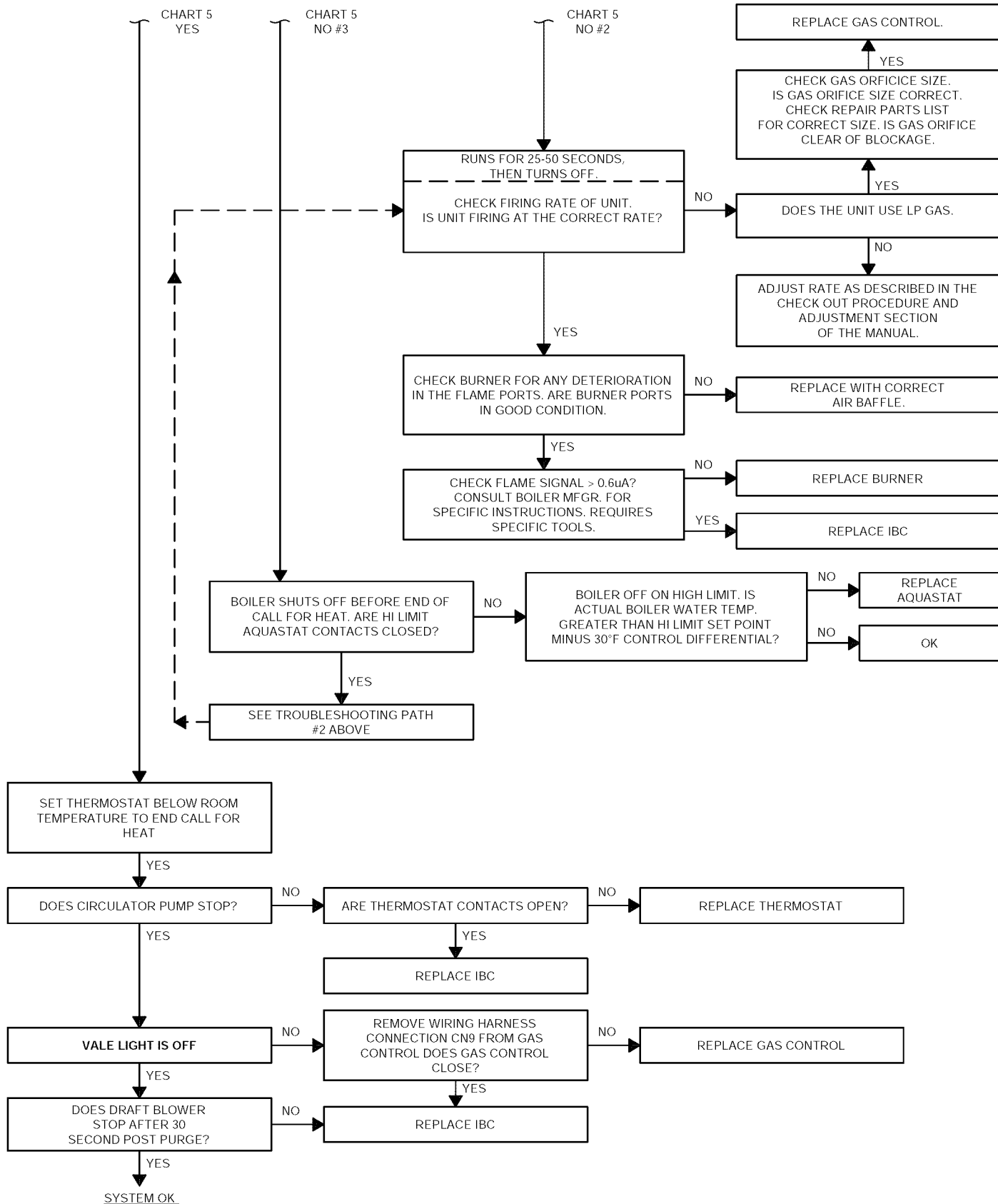

What Is System Status?

The following steps and diagram indicate the locations of the connection points required to check the differential air pressure.

The differential air pressure switch is a safety device which will prevent the boiler from firing if there is an air intake, boiler heat exchanger or vent blockage.

Turn off service switch, or lower thermostat setting.

Remove vinyl caps from Tee and 4-way connector.

Install testing lines as shown to inclined manometer or differential pressure gauge with the ability to read 0.01" to 2.0" w.c.

Turn on service switch and set thermostat to call for heat.

BOILER STATUS	DIFFERENTIAL PRESSURE (W.C.)	PRESSURE SWITCH CONNECTS
Not Running	0"	Normally Open
Setpoint	1.00" for Model-100	
	1.35" for Model-75	
	1.55" for Model-50	
Running Without Blockage	Greater Than Setpoints	Closed
Running With Blockage	Less Than or Equal to Setpoints	Open

If manometer readings do not correspond to the chart above, check for possible causes:

- Blockage or moisture in suction lines
- Blockage in air intake or vent pipes
- Undersized air intake or vent pipes
- Loose blower wheel or motor shaft
- Incorrect pressure switch or pressure switch setpoint

When pressure reading is proper and the pressure switch is operating properly, remove testing lines and reinstall vinyl caps to Tee and 4-way connector.

