

Model numbers

L46S604

L55S604

**HITACHI**  
Inspire the Next



# Owners Guide

Thank you for purchasing this Hitachi product. Please read these instructions carefully.  
 For additional assistance please call 800.HITACHI (800.448.2244) or visit our website at [www.hitachi.us/tv](http://www.hitachi.us/tv).  
 Keep this owners guide for future reference.

Record the model name and serial number of your LCD Television for future reference.  
 This information is located on the back and right side of the television.

MODEL NAME. \_\_\_\_\_ SERIAL NO. \_\_\_\_\_

## TABLE OF CONTENTS

IMPORTANT SAFETY INSTRUCTIONS .....	2-5
FIRST TIME USE .....	6-17
THE REMOTE CONTROL .....	18-27
ON-SCREEN DISPLAY .....	28-41
USEFUL INFORMATION .....	42-48
LIMITED WARRANTY .....	49
END USER LICENSE AGREEMENT FOR HITACHI DTV SOFTWARE .....	50-54
APPENDIXES .....	55
INDEX .....	56



# Important Safety Instructions



## SAFETY POINTS YOU SHOULD KNOW ABOUT YOUR HITACHI LCD TELEVISION

Our reputation has been built on the quality, performance, and ease of service of Hitachi LCD televisions.

Safety is also foremost in our minds in the design of these units. To help you operate these products properly, this section illustrates safety tips which will be of benefit to you. Please read it carefully and apply the knowledge you obtain from it to the proper operation of your Hitachi LCD television.

**CAUTION**  
**RISK OF ELECTRIC SHOCK**  
**DO NOT OPEN**

CAUTION: TO REDUCE THE RISK OF ELECTRIC SHOCK,  
DO NOT REMOVE COVER (OR BACK).  
NO USER SERVICEABLE PARTS INSIDE.  
REFER SERVICING TO QUALIFIED SERVICE PERSONNEL.



The lightning flash with arrowhead symbol, within an equilateral triangle, is intended to alert the user to the presence of uninsulated "dangerous voltage" within the product's enclosure that may be of a sufficient magnitude to constitute a risk of electric shock to a person.



The exclamation point within an equilateral triangle, is intended to alert the user to the presence of important operating and maintenance (servicing) instructions in the literature accompanying the appliance.

### READ BEFORE OPERATING EQUIPMENT

Follow all warnings and instructions marked on this LCD television.

1. Read these instructions.
2. Keep these instructions.
3. Heed all warnings.
4. Follow all instructions.
5. Do not use this apparatus near water.
6. Clean only with a dry cloth.
7. Do not block any ventilation openings. Install in accordance with the manufacturer's instructions.
8. Do not install near any heat sources such as radiators, heat registers, stoves, or other apparatus (including amplifiers) that produce heat.
9. Do not defeat the safety purpose of the polarized or grounding-type plug. A polarized plug has two blades with one wider than the other. A grounding type plug has two blades and a third grounding prong. The wide blade or the third prong are provided for your safety. If the provided plug does not fit into your outlet, consult an electrician for replacement of the obsolete outlet.
10. Protect the power cord from being walked on or pinched particularly at plugs, convenience receptacles, and the point where they exit from the apparatus.
11. Only use the attachments/accessories specified by the manufacturer.
12. Use only with the cart, stand, tripod, bracket, or table specified by the manufacturer, or sold with the apparatus. When a cart is used, use caution when moving the cart/apparatus combination to avoid injury from tip-over.
13. Unplug this apparatus during lightning storms or when unused for long periods of time.
14. Refer all servicing to qualified service personnel. Servicing is required when the apparatus has been damaged in any way, such as power-supply cord or plug is damaged, liquid has been spilled or objects have fallen into the apparatus, the

- apparatus has been exposed to rain or moisture, does not operate normally, or has been dropped.
15. Televisions are designed to comply with the recommended safety standards for tilt and stability. Do not apply excessive pulling force to the front, or top, of the cabinet which could cause the product to overturn resulting in product damage and/or personal injury.
16. Follow instructions for wall, shelf or ceiling mounting as recommended by the manufacturer.
17. An outdoor antenna should not be located in the vicinity of overhead power lines or other electrical circuits.
18. If an outside antenna is connected to the receiver be sure the antenna system is grounded so as to provide some protection against voltage surges and built up static charges. Section 810 of the National Electric Code, ANSI/NFPA No. 70-1984, provides information with respect to proper grounding for the mast and supporting structure, grounding of the lead-in wire to an antenna discharge unit, size of grounding connectors, location of antenna discharge unit, connection to grounding electrodes and requirements for the grounding electrode.

#### NOTE

To the CATV system installer: This reminder is provided to call the CATV system installer's attention to Article 820-44 of the NEC that provides guidelines for proper grounding and, in particular, specifies that the cable ground shall be connected to the grounding system of the building, as close to the point of cable entry as practical.

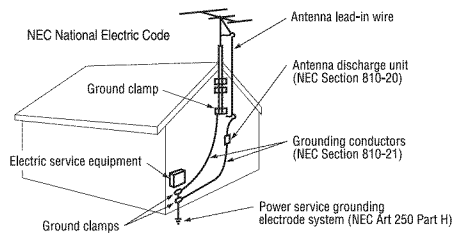

### Power source

This LCD television is designed to operate on 120 volts 60 Hz, AC current. Insert the power cord into a 120 volts 60 Hz outlet. The mains plug is used as the disconnect device and shall remain readily operable.

To prevent electric shock, do not use the LCD television's (polarized) plug with an extension cord, receptacle, or other outlet unless the blades and ground terminal can be fully inserted to prevent blade exposure.

Never connect the LCD television to 50 Hz, direct current, or anything other than the specified voltage.

This television's factory default settings as shipped meet ENERGY STAR requirements.

Please see the Energy Options section of this owners guide for more energy saving tips.



Adjust only those controls that are covered in the instructions, as improper changes or modifications not expressly approved by Hitachi could void the user's warranty.

# Important Safety Instructions



## Warning



- To reduce the risk of fire or electric shock, do not expose this apparatus to rain or moisture.
- The LCD television should not be exposed to dripping or splashing and no objects filled with liquids, such as vases, should be placed on the television.
- This apparatus shall be connected to a mains socket outlet with a protective earthing connection.

## Public viewing of copyrighted material

Public viewing of programs broadcast by TV stations and cable companies, as well as programs from other sources, may require prior authorization from the broadcaster or owner of the video program material.

This product incorporates copyright protection technology that is protected by U.S. patents and other intellectual property rights. Use of this copyright protection technology must be authorized, and is intended for home and other limited payper-view uses only unless otherwise authorized. Reverse engineering or disassembly is prohibited.

## Lead/Mercury Notice



This product contains lead and one or more non-replaceable mercury backlights. Do not put in trash. Recycle or dispose of according to applicable laws. For product recycling and disposal information, contact your local government agency or visit [www.eiae.org](http://www.eiae.org) (in USA) or [www.epsc.ca](http://www.epsc.ca) (in Canada). **FOR MORE INFORMATION, CALL 800.HITACHI.**

## FEDERAL COMMUNICATIONS COMMISSION NOTICE

This equipment has been tested and found to comply with the limits for a Class B digital device, pursuant to Part 15 of the FCC Rules. These limits are designed to provide reasonable protection against harmful interference in a residential installation. This equipment generates, uses and can radiate radio frequency energy and if not installed and used in accordance with the instructions, may cause harmful interference to radio communications. However, there is no guarantee that interference will not occur in a particular installation. If this equipment does cause harmful interference to radio or television reception, which can be determined by turning the equipment off and on, the user is encouraged to try to correct the interference by one or more of the following measures:

- Reorient or relocate the receiving antenna.
- Increase the separation between the equipment and the receiver.
- Connect the equipment into an outlet on a circuit different from that to which the receiver is connected.
- Consult the dealer or an experienced radio/television technician for help.



## Modifications

The FCC requires the user to be notified that any changes or modifications made to this device that are not expressly approved by Hitachi America, Ltd. may void the user's authority to operate the equipment.

## Cables

Connections to this device must be made with shielded cables with metallic RF/EMI connector hoods to maintain compliance with FCC Rules and Regulations.

Any cables or power code supplied with the system must be replaced with identical parts in order to assure compliance with FCC rules. You may order those replacement parts from Hitachi.

*This LCD Television receiver will display television closed captioning, (  or  ), in accordance with paragraph 15.119 and 15.122 of the FCC rules.*

## Declaration of Conformity

This device complies with part 15 of the FCC Rules. Operation is subject to the following two conditions :

(1)This device may not cause harmful interference and (2)This device must accept any interference received, including interference that may cause undesired operation.

For questions regarding this declaration, contact:

Hitachi America, Ltd.  
900 Hitachi Way  
Chula Vista, CA 91914-3556  
Tel. 800.448.2244(800.HITACHI)  
ATTN: Customer Relations

# CHILD SAFETY:

It Makes A Difference How and Where  
You Use Your Flat Panel Display

Congratulations on your purchase!

As you enjoy your new product, please keep these safety tips on mind:



## HITACHI CARES!

- The consumer electronics industry is committed to making home entertainment enjoyable and safe.
- Please note the American Academy of Pediatrics discourages television viewing for children younger than two years of age.
- The home theater entertainment experience is a growing trend and larger flat displays are popular purchases. However, flat panel displays are not always supported on the proper stands or installed according to the manufacturer's recommendations.
- Flat Panel displays that are inappropriately situated on dresser, bookcases, shelves, desks, speakers, chest or carts may fall over and cause injury.

## TUNE INTO SAFETY

- One size does NOT fit all. Follow the manufacturer's recommendations for the safe installation and use of your flat panel display.
- Carefully read and understand all enclosed instructions for proper use of this product.
- Don't allow children to climb on or play with furniture and television sets.
- Don't place flat panel displays on furniture that can easily be used as steps, such as a chest of drawers.
- Remember that children can become excited while watching a program, especially on a "larger than life" flat panel display. Care should be taken to place or install the display where it cannot be pushed, pulled over, or knocked down.
- Care should be taken to route all cords and cables connected to the flat panel display so that they cannot be pulled or grabbed by curious children.

## WALL MOUNTING: IF YOU DECIDE TO WALL MOUNT YOUR FLAT PANEL DISPLAY, ALWAYS:

- Use a mount that has been recommended by the display manufacturer and/or listed by an independent laboratory (such as UL, CSA, ETL).
- Follow all instructions supplied by the display and wall mount manufacturers.
- If you have any doubts about your ability to safely install your flat panel display, contact your retailer about professional installation.
- Make sure that the wall where you are mounting the display is appropriate. Some wall mounts are not designed to be mounted to walls with steel studs or old cinder block construction. If you are unsure, contact a professional installer.
- A minimum of two people are required for installation. Flat panel displays can be heavy.



# PRECAUTIONS AND REMINDERS

Do not place the unit on uneven surfaces, this may drop or damage the unit, it may also cause personal injury.

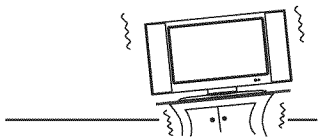

Unplug immediately if any foreign materials falls into the TV or if the TV fell down.

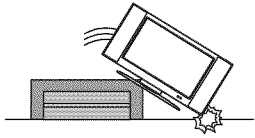

Do not cover or block any vents and openings of the TV. Inadequate ventilation may shorten the life of the display unit and cause overheating.

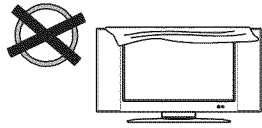

Unplug immediately if there is a malfunction on the TV like no picture, no video/audio or if there is smoke and bad odor coming from the TV.

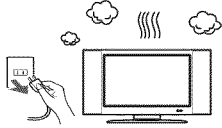

Do not open the TV cabinet.

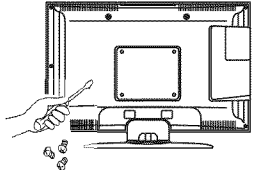

Avoid direct sunlight, dusty, high humidity and smokey locations.

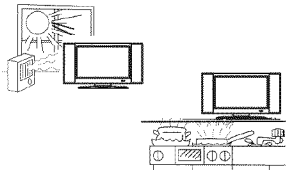

Do not throw any objects inside the TV like metals, coins or any other flammable materials.

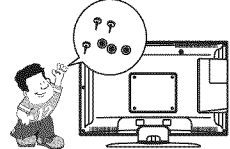

Remember to unplug the power cord from the AC outlet before cleaning. Do not use liquid cleaners or aerosol cleaners to clean the display.

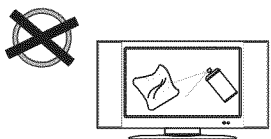

Do not place the TV near water, such as a bathtub, shower rooms, kitchen sink, laundry tub or swimming pool. Avoid liquid containers on top of the unit.

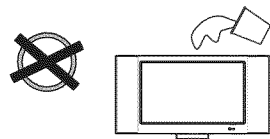

Do not place the TV in confined spaces or inside a box when the TV is operating.

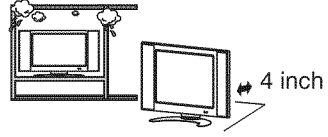

Make sure to unplug the TV when not in use for a long period of time (days).

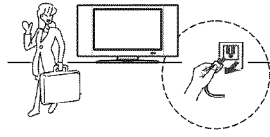

Do not pick up or handle the TV from where the TV connects to the stand. Injury may occur if the TV is picked up or handled from this area.

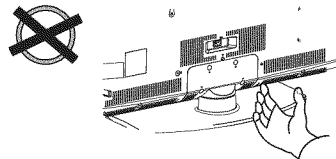

 Notice for remote control

Avoid dropping the unit.



Avoid liquids on it.



Avoid aerosol cleaners.



# Accessories

Check to make sure you have the following accessories before disposing of the packing material.

- ① Remote Control Unit  
CLU-4997S  
(Part No. HL02567)

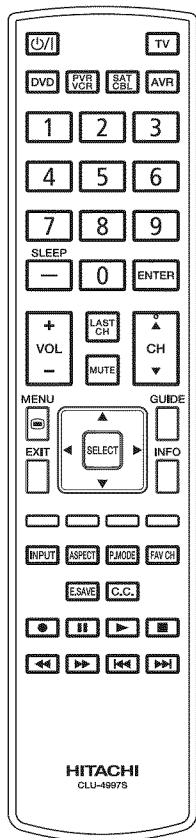

- ② “AAA” Size Batteries (2)

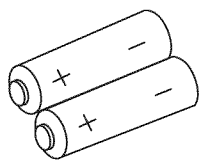

- ③ Power Cord

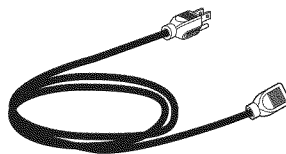

- ④ Owners Guide

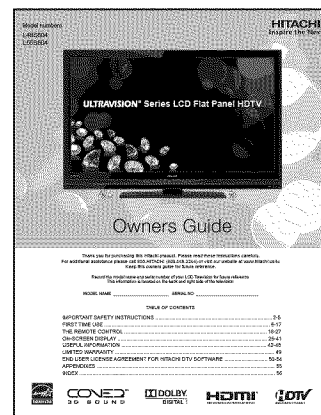

- ⑤ Easy Graphic Guide

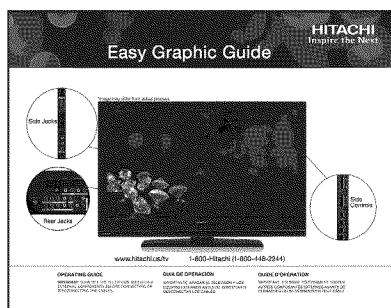

- ⑥ Stand Screws (4)



(M6x12: Part No. 0M1G1760 12225 CR3)

- ⑦ Stand Base

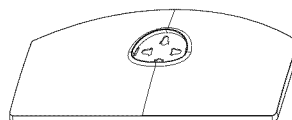

(Part No. A34T1371AFL 1L0100 & Q15T0840101)

For optional accessories, please access our web site at: [www.hitachi.us/tv](http://www.hitachi.us/tv)



- Ceiling mounting is not recommended. Mounting the panel on the ceiling does not provide adequate ventilation for the electronics or proper support for the front panel. This LCD television product is designed for a maximum tilting angle of 45 degrees from vertical.
- Please see page 8 for important information related to wall mounting.

## REMOTE CONTROL BATTERY INSTALLATION AND REPLACEMENT

The remote control operates on 2 “AAA” batteries.

1. Open the battery cover of the remote control by pushing and pulling it in the direction of the arrow.
2. Insert two new “AAA” size batteries for the remote control. When replacing old batteries, push them towards the springs and lift them out.
3. Match the batteries to the (+) and (-) marks in the battery compartment.
4. Insert the bottom of the battery, the (-) side, into the battery compartment first, push towards the springs and insert the top of the battery, the (+) side, into place. Do not force the battery into the battery compartment.
5. Close the battery cover making sure the tabs rest in the corresponding holes and push down the cover until it clicks shut.

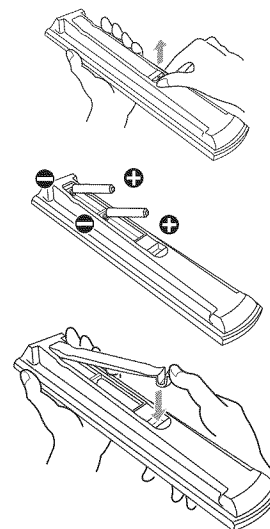

- Do not insert batteries with ‘+’ and ‘-’ polarities reversed as this may cause the batteries to swell or rupture resulting in leakage.
- Never mix used and new batteries in the device.
- Replace all the batteries in the device at the same time.
- Remove the batteries if the remote control is not going to be used for an extended period of time.
- The batteries (batteries installed) shall not be exposed to excessive heat such as sunshine, fire, etc.

# How To Install Your New Hitachi LCD Television

Take the following precautions to prevent the LCD Television from tipping over and possibly causing injury. It is important to mount the unit on a stable and flat surface.

## ASSEMBLY OF THE BASE

### IMPORTANT:

The base of the LCD TV must be assembled prior to use.

1. Place the TV unit face down on a soft and flat surface covered by a blanket, foam, cloth, etc. to prevent any damage or scratches to the LCD TV.
2. Carefully align and insert the Base to the TV stand post.
3. Insert the screws included with the accessories to the bottom of the base and tighten the base to the stand.

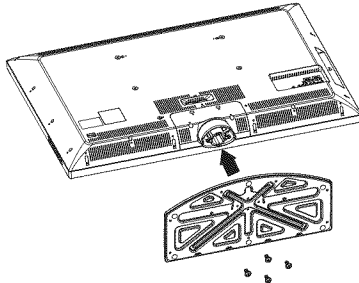

### Caution when moving the main unit

As this product is heavy, whenever it is moved, at least two people are required to transport it safely. Whenever the unit is moved, it should be lifted forward using the top and bottom on both sides of the Television for stability.

When moving the Television, lift from the corners, then support the top frame as shown below.

Please use caution when handling the left and right bottom corners of the TV, as these areas protrude slightly from the TV's frame. Handle this area with care to avoid damaging the unit and the possibility of personal injury.

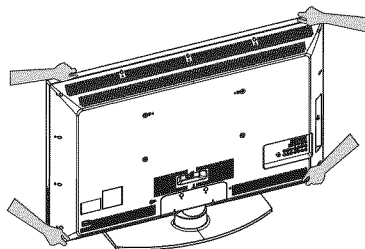

### Location

Select an area where sunlight or bright indoor illumination will not fall directly on the picture screen. If so, drapes or screens can be used to reduce the reflection.

Also, be sure that the location selected allows a free flow of air to and from the perforated back cover of the set. In order to prevent an internal temperature increase, maintain a space of 10 cm (4 inches) from the sides/back of the Television, and 30 cm (12 inches) from the top of the television to the ceiling. To avoid cabinet warping, cabinet color changes, and increased chance of set failure, do not place the TV where temperatures can become excessively hot, for example, in direct sunlight or near a heating appliance, etc.

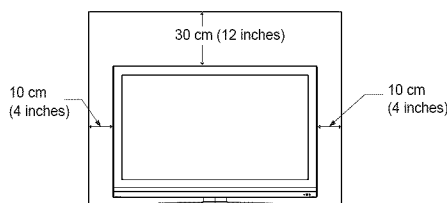

### NOTES



- Do not block the ventilation holes of the LCD Television. Blocking the ventilation holes might cause overheating and damage.
- In case of an abnormal symptom, unplug the power cord and contact 800.HITACHI.
- If you purchased a wall mount bracket, is it recommended that you ask for professional installation.
- Install the unit at a proper area where it does not expose anyone to any danger of hitting themselves (For example: their hands, head or face, etc.) against the edge of the unit that could cause personal injury.

### Power Cord Installation

The power cord provided with your new LCD Television needs to be installed correctly to avoid its disconnection when rotating the TV on its Table Top Stand.

Located on the back of the TV there is one plastic clamp to hold the Power cord. Please follow the instructions below.

1. Pass the power cord through the wire clamp and connect it to the TV.
2. Close the clamp to fix the power cord to the TV.
3. All the cables connected to the TV will be held by this clamp.

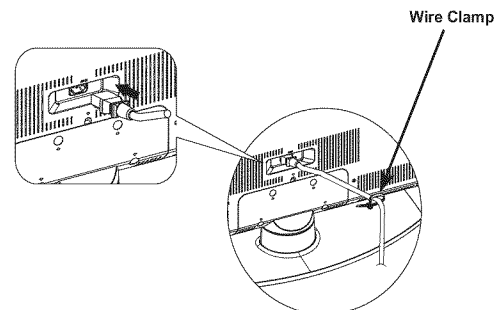

### Securing to a Wall

1. Use a metallic wire (two locations) to fasten the set to the clamping screw on the rear of the LCD TV as shown below.
2. Keep the LCD television 4 inches away from the wall, except when mounted using the wall mount bracket, and secure to the wall as shown below:

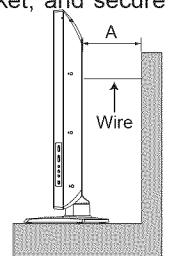
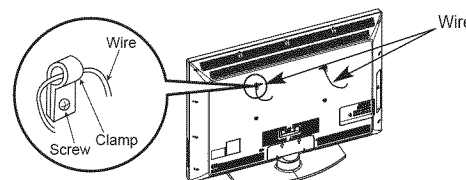

	A
46"	4 in.
55"	10 cm.

# How To Install Your New Hitachi LCD Television

## WALL MOUNTING SETUP

### STEP (1) : REMOVE THE STAND BASE FROM THE LCD TELEVISION

In order to remove the stand from the TV safely, please put the TV set on a soft and flat surface (blanket, foam, cloth, etc.) to prevent any damage; then remove the screws as shown below to separate the Table Top Stand from the TV. Now the Stand can be separated from the TV. Useful dimensions for the WALL MOUNT assembly are illustrated on page 46 and 47.

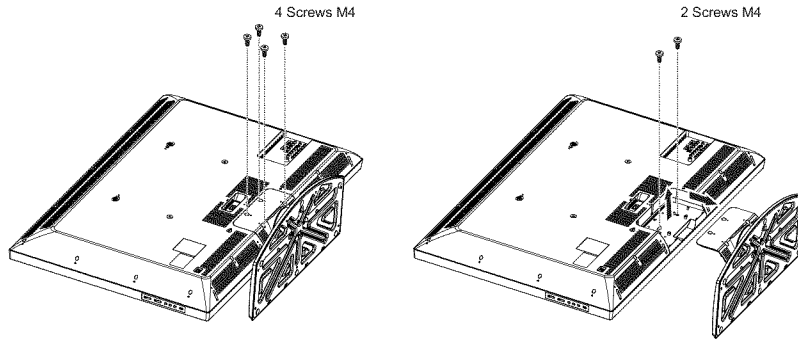

### STEP (2) : INSTALL THE WALL MOUNT BRACKETS ON THE LCD TELEVISION USING 4 SCREWS.

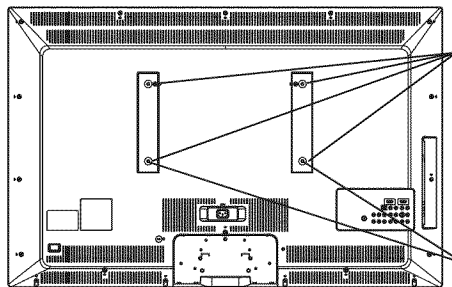

Screw mounting holes (4 locations) for use with a wall mount bracket.  
DO NOT reuse the original screws that were in these screw mounting holes or the screws removed in STEP(1) above, as such screws are not long enough to properly secure the TV to the wall bracket. Please refer to example at right and caution below to determine proper screw length.

Wall Mount Brackets

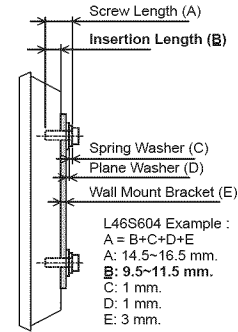

- For Wall Mount assembly, please refer to the Installation Manual of the Wall Mount Unit.

- The screw type :Thread ISO M6 (Metric type, do not use Standard type).



Insertion length (B) of the screws must be (i) within 9.5~11.5 mm for L46S604, or (ii) within 15.5~17.5 mm for L55S604. If the length is less than specified, the TV's weight cannot be maintained. If the length is more than specified, a space is created between the Wall Mount Bracket and the LCD Television. This insertion length is **very important**.

### STEP (3) : TIPS TO CONSIDER FOR THE LOCATION OF THE LCD TELEVISION.

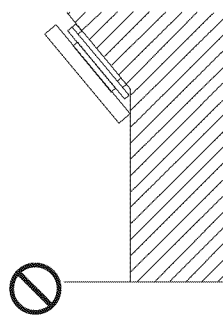
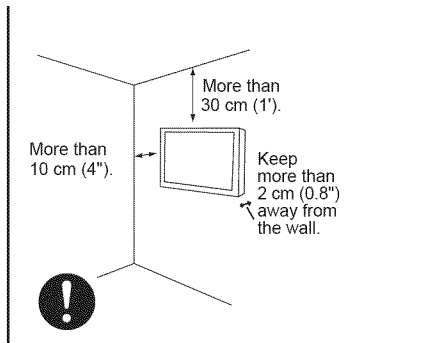

- Do not block the ventilation holes. In addition please keep a certain distance around the TV and make sure not to obstruct ventilation. Blocking the ventilation holes may cause fire or defect.

- If you purchased a Wall Mount bracket, please ask for a professional installation. Do not install by yourself.
- This LCD unit features an advanced ventilation system configured for vertical installation. A knowledgeable and experienced professional technician can perform other mounting or installation orientations (e.g., horizontal, tilted) provided that you specifically inform the technician of the unit's specialized ventilation needs. Call 800.HITACHI for additional info and guidance.



Although this LCD Display Panel can be installed using a variety of third party wall mounting brackets/devices, such third party brackets/devices have not been tested or approved by Hitachi for use or compatibility with this LCD Display Panel. Accordingly, Hitachi accepts no responsibility or liability for any injuries or property damage resulting from the use of such third party brackets/devices. Hitachi strongly advises that any

installation of this LCD Display Panel using wall mounting brackets/devices be performed only by a qualified and experienced television installation technician who has completed a thorough evaluation of:

- a) the weight-bearing strength and stability of the intended wall mount surface; and
- b) the weight-bearing strength and compatibility of the intended wall mount brackets/device.



# Side Panel Jacks & Controls

FIRST TIME USE

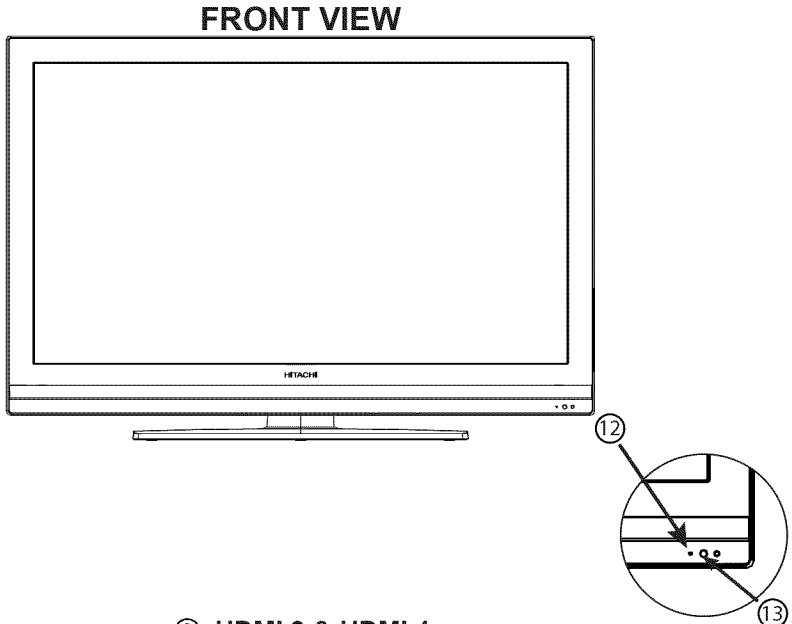
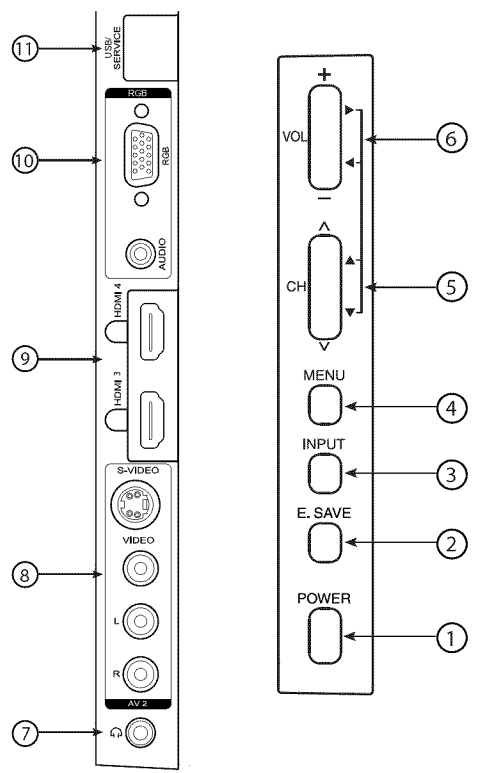

**① POWER Button**

This button is for turning ON the LCD TV, in order to turn the TV On, the standby indicator must be lit red. If the indicator is off, plug the power cord into the AC outlet.

**② ENERGY SAVE Button**

Press this button to set power consumption reduction based on three levels (Min, Medium, Max).

**③ INPUT Button**

Press this button to access the INPUT menu.

**④ MENU Button**

This button allows you to enter the MENU, making it possible to set TV features to your preference without using the remote control. This button also serves as the Return button when in the MENU system.

**⑤ CHANNEL Selector**

Press these buttons until the desired channel appears in the top right corner of the TV screen. These buttons also serve as the CURSOR down (▼) and up (▲) buttons when in the MENU system.

**⑥ VOLUME (+/-) Level**

Press these buttons to adjust the sound level. The volume level will be displayed on the TV screen. These buttons also serve as the CURSOR left (◀) and right (▶) buttons when in the MENU system.

**⑦ HEADPHONE Jack**

Use this jack to connect headphones.

**⑧ COMPOSITE AV2 Jack**

AV2 input provide composite Video and S-Video jacks for connecting device with this capability, such as a DVD player, Game Console or Camcorders.

**⑨ HDMI 3 & HDMI 4**

Use these side HDMI inputs for AV device such as set top boxes or DVD players equipped with an HDMI output connection (see page 14 for reference).

**⑩ RGB (PC and AUDIO IN)**

Video and audio input from computer.

**⑪ USB MULTIMEDIA/SERVICE Slot**

This USB slot is for use with the multimedia feature and future software upgrades.

**⑫ POWER LIGHT Indicator**

To turn the TV ON, press the POWER button (①). A blue indicator lamp located on the lower right corner of the front bezel illuminates to indicate the TV power is ON.

Indicating Lamp	Power Status	Operating
Lights Red	OFF (Stand-by)	When the LCD TV is plugged to the AC outlet.
Lights Blue	ON	TV Power is ON; picture is shown.
Quickly Blinking Red	ON	The TV is powering OFF. It will soon be in the Off (Stand-by) state.

**⑬ REMOTE CONTROL Sensor**

Point your remote control at this area when selecting channels, adjusting volume, etc.

**NOTES**

- Your Hitachi LCD TV will not show any picture if there is no video input when AV1, AV2, Component1 or 2, or HDMI 1, 2, 3 or 4 is selected. Instead, a message will indicate "No Signal", and the Power Light will remain Blue until the TV is turned off or in Stand-by mode (lights red) when not in use.
- The remote control can turn the TV ON/OFF as well as control various devices and any compatible HDMI CEC devices.
- Please do not put anything around the remote control sensor.

# Rear Panel Jacks

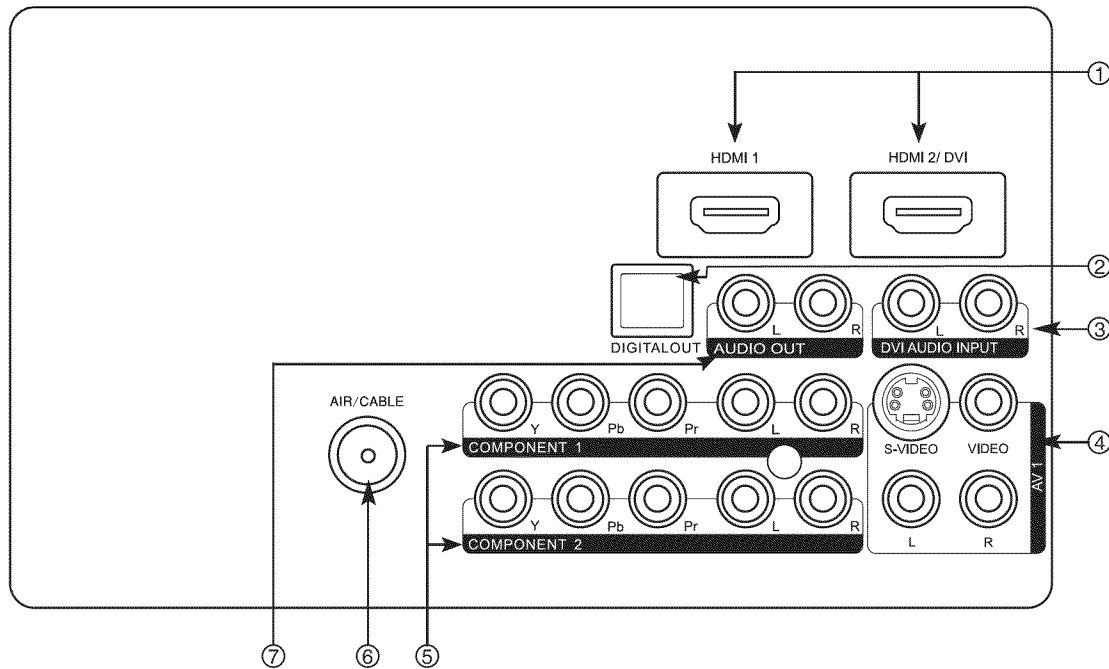

**① HDMI 1 & HDMI 2/DVI (High Definition Multimedia Interface)**

HDMI input for your AV device such as set top boxes or DVD players equipped with an HDMI output connection.

**② DIGITAL OUT (Optical Digital Audio)**

This jack provides Digital Audio Output for your audio device that is RAW and PCM compatible, such as an audio amplifier.

**NOTE** The Digital Output option will grayout with all input sources, except with a digital program channel on the Air/Cable input source.

**③ DVI AUDIO Input**

This jack provides Audio Input from a DVI device when connected to the HDMI 2 Input. A DVI (device) to HDMI (TV) connection must be made to HDMI 2.

**NOTES**

- It is not necessary to connect the DVI Audio Input when the connection to HDMI 2 is a HDMI to HDMI connection.
- The DVI Audio Input is only compatible with the HDMI 2 Input.

**④ COMPOSITE AV1 Jacks**

AV1 input provides composite Video and S-Video jacks for connecting device with this capability, such as a DVD player, Game Console or Camcorders.

**⑤ COMPONENT: Y-PbPr and Audio Inputs**

Component 1 and 2 provide Y-PbPr and Audio jacks for connecting device with this capability, such as a DVD player or set top box.

**NOTES**

- Your component outputs may be labeled Y, B-Y, and R-Y. In this case, connect the components B-Y output to the TV's Pb input and the components R-Y output to the TV's Pr input.
- Your component outputs may be labeled Y-CbCr. In this case, connect the component Cb output to the TV's Pb input and the component Cr output to the TV's Pr input.
- It may be necessary to adjust Tint to obtain optimum picture quality when using the Y-PbPr inputs (see page 31).

**⑥ AIR/CABLE Terminal**

To switch between cable and air, go to the Channels Menu option to change the signal source Cable or Air (see page 40).

**⑦ AUDIO OUT Jack**

This jack provides stereo audio output from your TV to your audio device, such as an audio amplifier.

# Quick Reference Remote Control Buttons and Functions

FIRST TIME USE

In addition to controlling all of the functions on your Hitachi LCD TV, the new remote control is designed to operate different types of devices, such as, DVD Players, Cable Boxes (CBL), set top boxes, satellite receivers (SAT), VCRs and compatible HDMI CEC DVD Players. The remote control must be programmed to control the chosen device. Please see pages 22~27 for a complete description of all features and programming of the remote control.

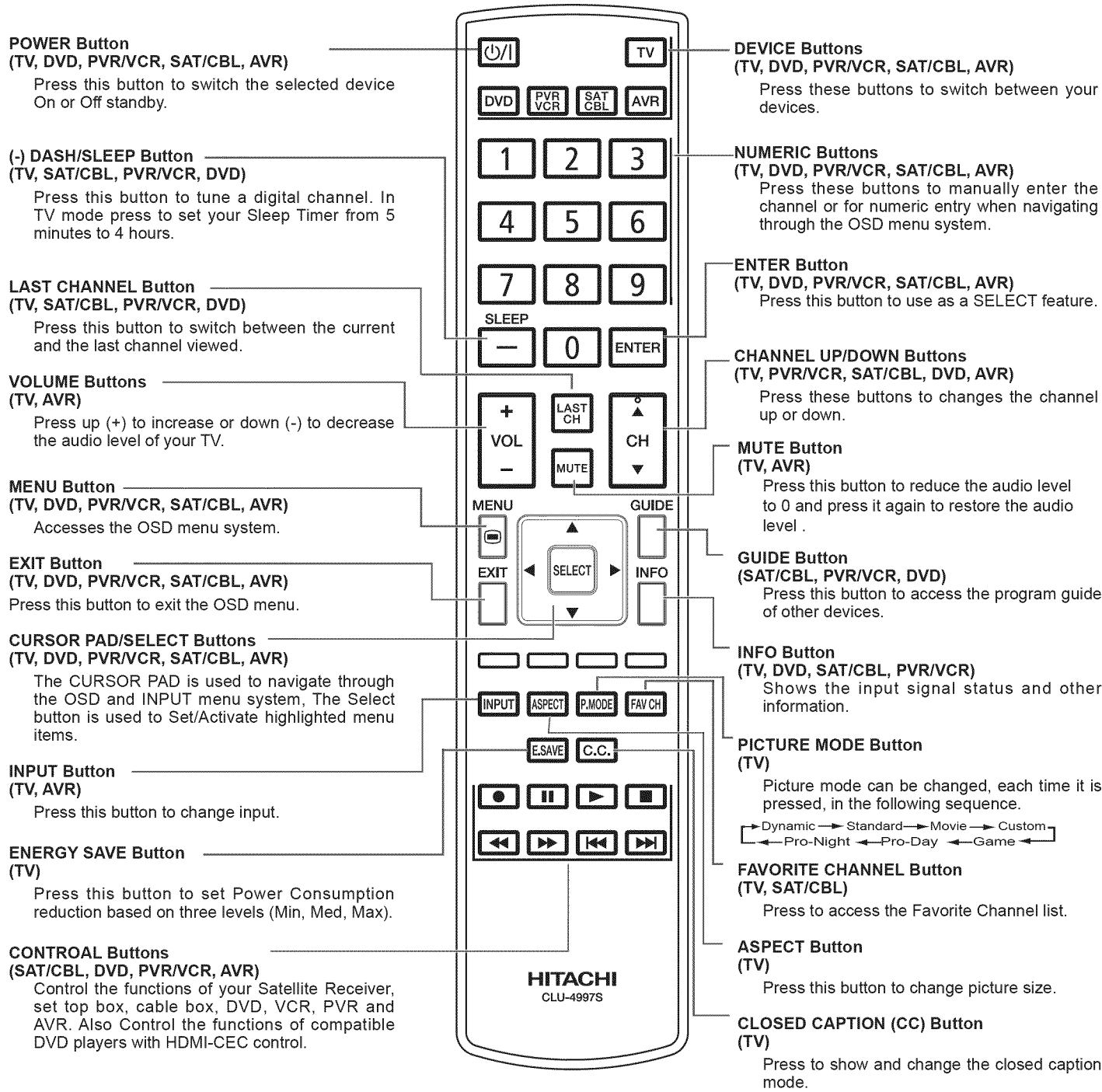

**LEGENDS**

- TV - Television
- DVD- Digital Video Disc Player
- AVR - Audio/Video Receiver
- VCR - Video Cassette Recorder
- SAT - Satellite Receiver
- PVR - Personal Video Recorder
- CBL - Cable Box

**NOTES**

- The TV's remote control sensor is located on the right bottom corner of the TV frame. To control TV functions, please point the remote control directly at the sensor for best results.
- The pause button "II" on the remote control can be used to Freeze the picture on the screen, in case this button is pressed by accident, please press it one more time to restore the moving picture.
- For HDMI CEC details please see page 38.

# Quick Setup Guide

Perform the following steps to quickly setup your new Hitachi LCD Television Set.

## 1. ANTENNA CONNECTION

Unless your LCD Television is connected to a cable TV system or to a centralized antenna system, a good outdoor color TV antenna is recommended for best performance. However, if you are located in an exceptionally good signal area that is free from interference and multiple image ghosts, an indoor antenna may be sufficient.

### a). VHF (75-Ohm) antenna/CATV (Cable TV)

When using a 75-Ohm coaxial cable system, connect the CATV coaxial cable to the AIR/CABLE (75-Ohm) terminal. Or if you have an antenna, connect the coaxial cable to the same AIR/CABLE terminal.

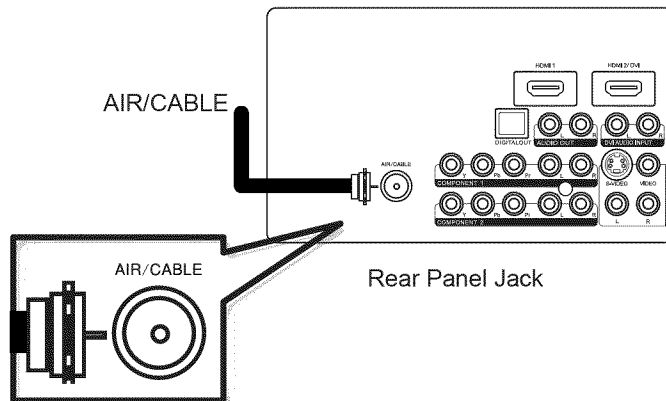
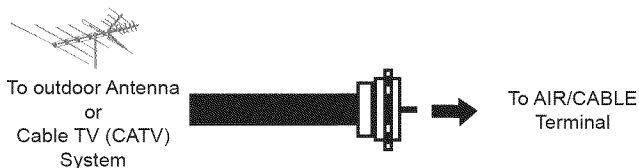

## 2. CONNECT YOUR NEW HITACHI LCD TV TO THE POWER SOURCE

a). Connect the power cord to your TV set and secure it with the Wire Clamp (see page 7).

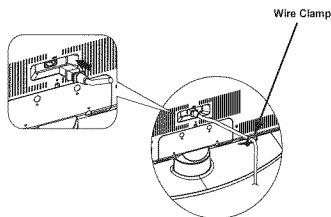

c). The Indicating Lamp will light red (Standby mode) and then light blue (picture is shown).

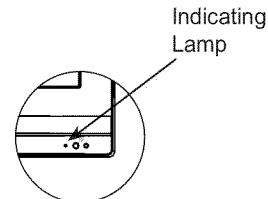

b). Connect the power cord to the AC outlet.

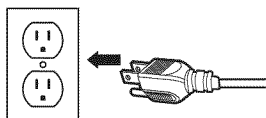

## 3. POWER ON/OFF YOUR NEW HITACHI LCD TV

Press the POWER button on the remote control or the Power button on the Side Control Panel to power on/off the LCD TV.

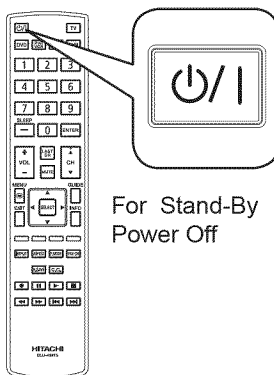

or

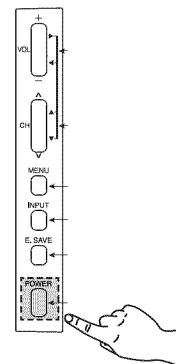

**NOTE** If the Indicating lamp is off, the POWER button on the remote control will not operate. Please make sure that the power cord is plugged to the AC outlet.

## 4. FOLLOW THE TV SETUP WIZARD INSTRUCTIONS ON NEXT PAGE

# TV Setup Wizard

Your Hitachi LCD television has a TV Setup Wizard feature which has the ability to help you easily setup the first time you turn on your TV and find the channels available in your area. Please follow the instructions below.

The first time you turn on your Hitachi LCD TV, the Energy Savings Initial Settings screen will appear. Please select either Home or Retail mode settings to advance to the TV Setup Wizard screen. If you select Home mode, this will save energy, and is intended for home use. Retail mode will set the Picture to Dynamic default settings and the picture will be brighter. This setting is intended for showroom and shop use. If later you want to change the Energy Savings Initial Settings, you can use the Setup menu (refer to page 37).



## NOTE

*Retail mode is intended for showroom or shop use. If you make adjustment changes in this mode, they will not be saved when TV's AC power is lost (e.g. power cord unplugged).*

The TV Setup Wizard screen automatically starts after the Energy Savings Initial Settings the first time the TV is turned on.

The second step is to set the language of your TV On Screen Menu. Select the language that you prefer. Use the CURSOR PAD ▲ or ▼ to select language and press the SELECT button on the remote control.



The third and fourth steps are to set the date and time. There are two options; one for automatic time setting in which you will select only the time zone in your area and the second option is a manual setup for the date and time. Use the CURSOR PAD to select and change the options with the remote control.



The fifth step is designed to find broadcasting or cable channels. There are two options, Air for an external antenna and Cable for a cable system provider in your home. Use the CURSOR PAD ▲ or ▼ to select a source and press the SELECT button on the remote control.



The sixth step will start the scanning feature to find the channels available on the antenna or cable system. Press the SELECT button on the remote control to start the channel scan.



The seventh step is the channel scanning process, it shows the scan of digital channels first and then the analog channels next. The scanning process will show how many channels have been found. Please be patient while the scanning process searches for the available channels in your area. If you wish to cancel the process, press the SELECT button on the remote control.

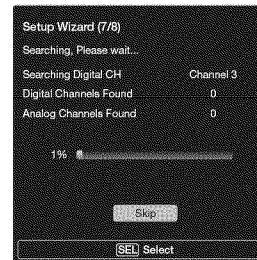

## NOTES

- Once the user cancels the wizard, the wizard will not be shown again.
- If you see the screen above and if you did not connect your antenna cables to your TV, turn off your TV, unplug the power cord and connect your cables according to the applicable connections in the "First Time Use" section of this Owners Guide.
- After completing the TV Setup Wizard, these screens will not appear again. For updating and adding the channels available in your area refer to the Add Channels to List feature on page 40.

The last step is the completion of process, it shows a brief message and you are ready to view TV programming. This final message will be shown for a few seconds and then the first detected channel will be tuned in. You may also press EXIT button on the remote control to tune to the first detected channel.

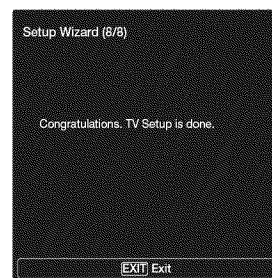

# Side Panel Connections

The following connection diagrams are offered as suggestions. However, you may need to modify them to accommodate your particular assortment of devices and features. For best performance, video and audio cables should be made from coaxial shielded wire. There are two SIDE panel HDMI jacks provided as a convenience to allow you to easily connect HDMI or DVI signals from a DVD, set top box, Video Game as shown in the following examples (When a DVI product is connected, the use of a separate audio device is necessary for audio, use an Audio Amplifier and connect to the Audio In jacks).

## A) CONNECTING HDMI SIGNAL



## B) CONNECTING DVI SIGNAL

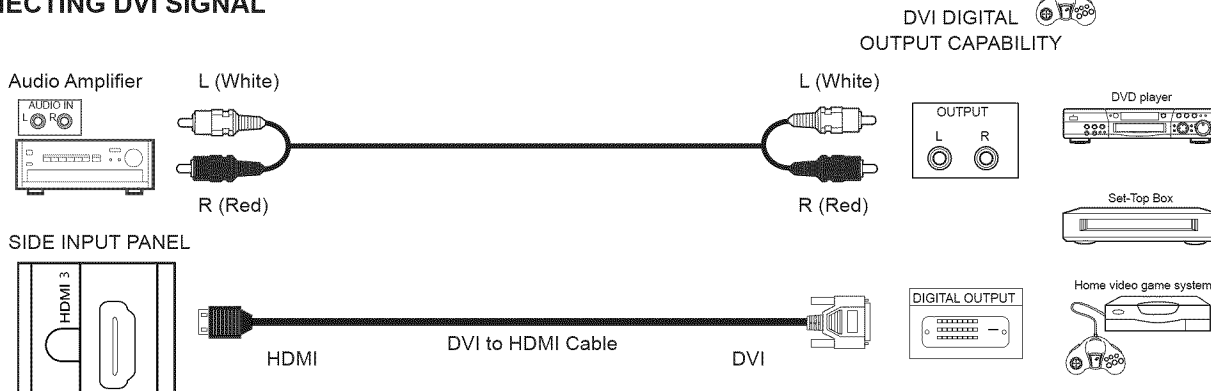

The SIDE panel VIDEO and S-VIDEO jacks are provided as a convenience to allow you to easily connect a Camcorder, DVD, Video Game and a VCR as shown in the following examples. (When connecting an S-VIDEO device, also connect the audio output into the Side Audio Input jacks).

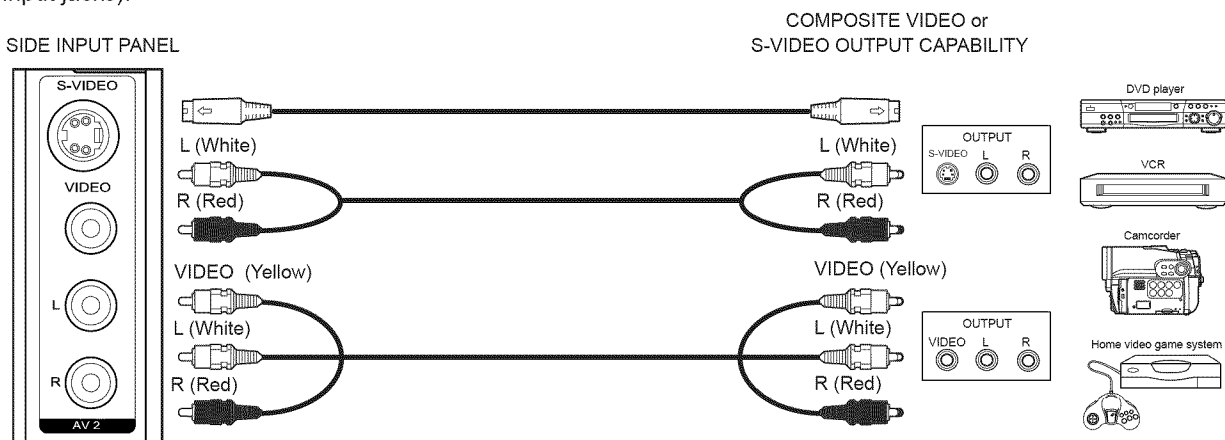

### NOTES

- Completely insert connection cord plugs when connecting to side panel jacks. If you do not, the picture and/or sound may be abnormal.
- Cable plugs are often color-coded. Match colors of plugs and jacks, i.e. connect red to red, white to white, etc.
- When making video connections, connect S-Video only or Video only. If both are connected, S-Video takes priority.

The exact arrangement you use to connect the VCR, Camcorder, DVD player, or HDTV set top box to your LCD TV is dependent on the model and features of each device. Check the owners guide of each device for the location of video and audio inputs and outputs.

## CONNECTING A PERSONAL COMPUTER

Use the RGB PC connection jack and the Analog Audio Input jacks to connect the PC.

1. Connect the RGB (D-sub 15 Pin) and AUDIO cable from the RGB and AUDIO OUT jack of the PC to the RGB and AUDIO jack, as shown on the Side Panel on the right.
2. Press the INPUT button, then select RGB from the INPUTS menu to view the signal from the PC.

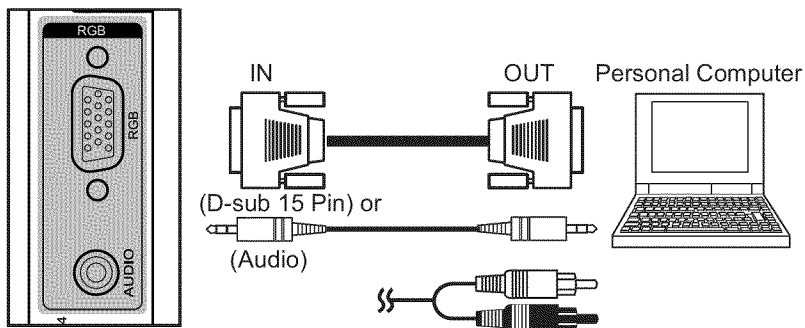

# Rear Panel Connections

## Before Operating External Video Devices

Connect an external device to one of the INPUT jacks, then press the INPUT button to show the Inputs List. Use the CURSORS (▲ and ▼) to select the Input of your choice. Then press the SELECT button to confirm your choice (see page 19).

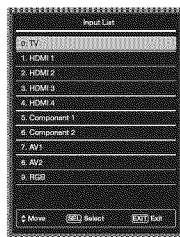
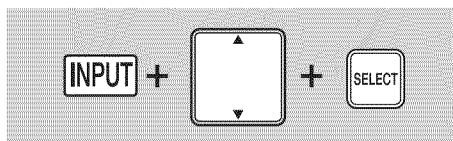

Example: Selecting the TV (AIR/CABLE) Input and highlight "0.TV".

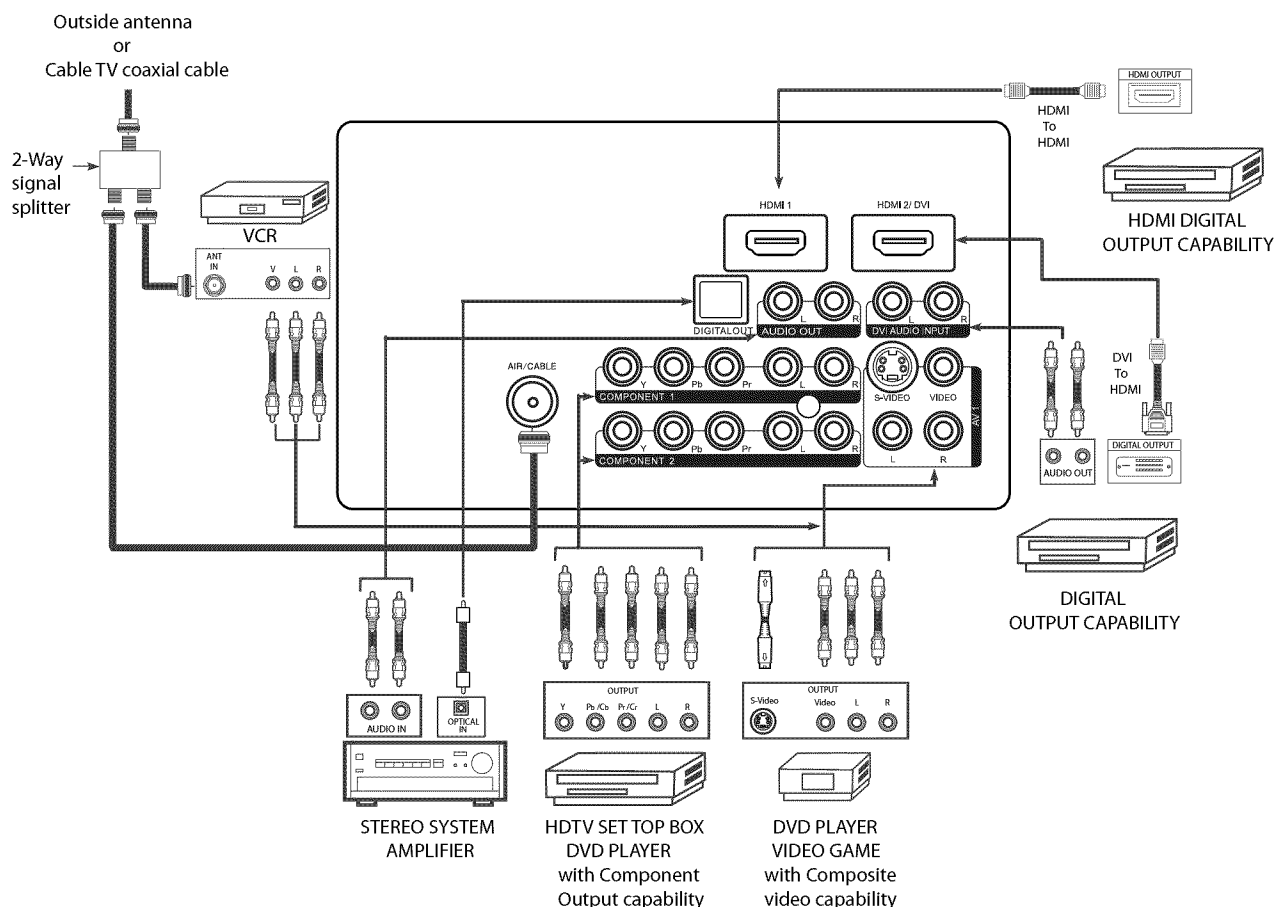

**NOTE** Cables are not included.

### TIPS ON REAR PANEL CONNECTIONS

- ◆ COMPONENT Y-PbPr (COMPONENT 1 & 2) or HDMI (1 & 2) connections are provided for high performance DVD players, VCRs etc. that have this feature. Use these connections in place of the standard video connection if your device has this feature.
- ◆ For additional information on connecting your other electronic devices, please refer to the device's owners guide.
- ◆ Connect only 1 component (VCR, DVD player, camcorder, etc.) to each input jack.
- ◆ Your component outputs may be labeled Y, B-Y, and R-Y. In this case, connect the components B-Y output to the TV's Pb input and the components R-Y output to the TV's Pr input.
- ◆ Your component outputs may be labeled Y-CbCr. In this case, connect the components Cb output to the TV's Pb input and the components Cr output to the TV's Pr input.
- ◆ It may be necessary to adjust TINT to obtain optimum picture quality when using the Y-PbPr inputs. (See page 31).
- ◆ When using a HDMI input from a set top box, it is recommended to use a 1080p, 1080i or 720p input signal.
- ◆ When the HDMI input is a 1080p signal, it is recommended that the length of the cable should be less than 5 meters.

- NOTES**
- Completely insert all connection cord plugs when connecting to rear panel jacks. The picture and sound that is played back will be abnormal if the connection is loose.
  - Cable plugs are often color-coded. Match colors of plugs and jacks, i.e. connect red to red, white to white, etc.

# Rear Panel Connections

## CONNECTING A VIDEO AND STEREO AUDIO DEVICE TO AV1

1. Connect the VIDEO and AUDIO cables from the VIDEO OUT and AUDIO OUT jacks of the VCR to the AV1 (VIDEO) jacks. A VCR connection to Rear Panel AV1 example is shown on the right.
2. Press the INPUT button, then select AV1 from the INPUTS menu to view the program from the VCR.

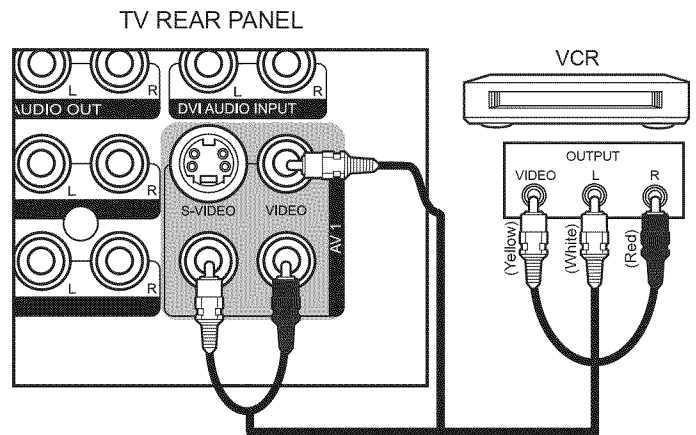

## CONNECTING A DEVICE AND STEREO AUDIO DEVICE TO COMPONENT 1 or 2: YPbPr

1. Connect the Y, Pb/Cb, Pr/Cr and AUDIO cables from the Y, Pb/Cb, Pr/Cr OUT and AUDIO OUT jacks of the DVD PLAYER or HDTV set top box to the COMPONENT 1 or 2 YPbPr and AUDIO jacks. A DVD connection to Rear Panel COMPONENT 2 example is shown on the right.
2. Press the INPUT button, then select COMPONENT 1 or 2 from the INPUTS menu to view the program from the DVD player or HDTV set top box.

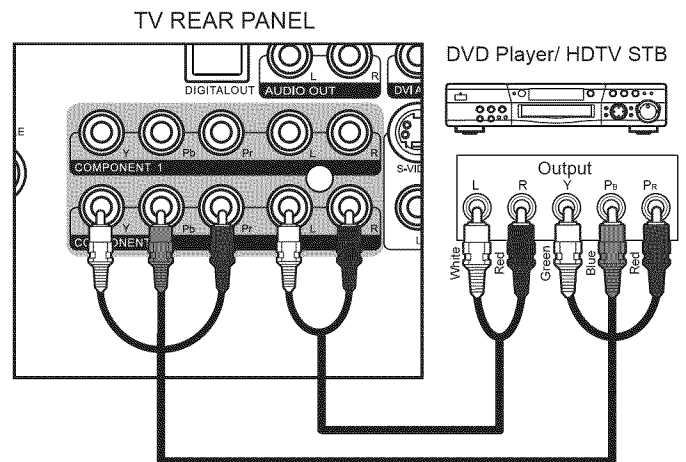

### NOTES

- Completely insert the connection cord plugs when connecting to rear panel jacks. If you do not, the picture and/or sound may be abnormal.
- Cable plugs are often color-coded. Match colors of plugs and jacks, i.e. connect red to red, white to white, etc.
- To return to the last channel viewed, select "0.TV" from the INPUTS menu.



# Rear Panel Connections

FIRST TIME USE

## CONNECTING AN DEVICE WITH HDMI OR DVI CAPABILITY TO HDMI 1 & HDMI 2

1. Connect the HDMI or DVI to HDMI connection cable from the output of the HDTV set top box or DVD player to the HDMI input as shown near the Rear panel at right.
2. With DVI output devices, connect a DVI to HDMI cable to the HDMI 2 input. Connect the audio out L and R cables to DVI Audio Input or connect the audio cables from the Audio output jack from the HDTV set top box or DVD player to an external audio amplifier as shown to the right.
3. Press the INPUT button, then select HDMI 1 or 2 to view the program from the HDTV set top box or DVD player.

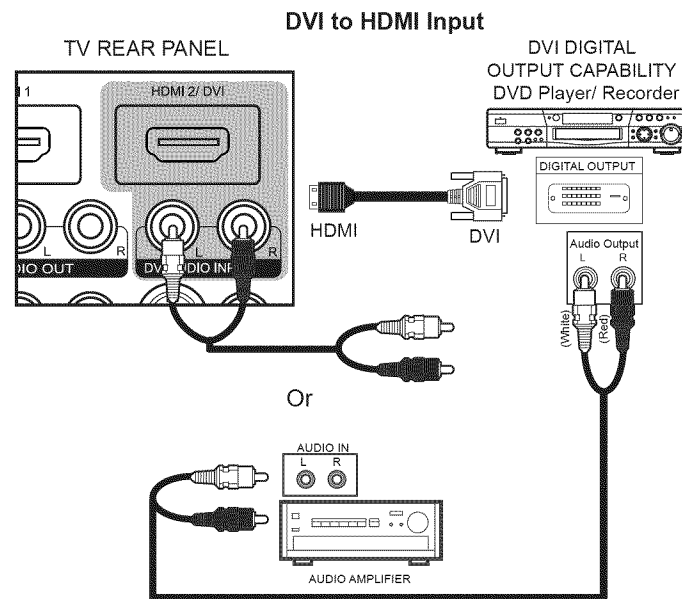
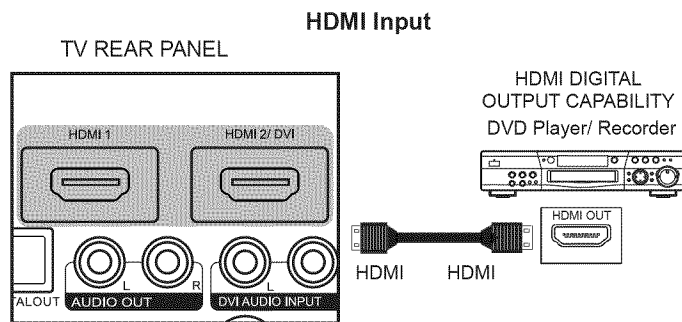

*Note: An external Audio amplifier can be used for the same purpose.*

### NOTES

- Completely insert the connection cord plugs when connecting to the rear panel jacks. If you do not, the picture and/or sound may be abnormal.
- When using a DVI to HDMI cable, connect the Audio Out L and R cables to an external audio amplifier.
- The HDMI input on HDMI 1, 2, 3 and 4 contains the copy protection system called High-bandwidth Digital Content Protection (HDCP). HDCP is a cryptographic system that encrypts video signals when using HDMI connections to prevent illegal copying of video contents.
- HDMI is not a "NETWORK" technology. It establishes a one-way, point-to-point connection for delivery of uncompressed video to a display.
- The connected digital output device controls the HDMI interface, so proper set-up of device user settings determines final video appearance.
- Only HDMI 2 can support DVI audio input.

## CONNECTING AN EXTERNAL AUDIO AMPLIFIER

To monitor the audio level of the LCD TV to an external audio amplifier, connect the system as shown on the right. The DIGITAL OUT and AUDIO OUT from the Rear Panel is a fixed output. The Volume of the amplifier is controlled by the amplifier, not by the LCD Television. The DIGITAL OUT jack outputs all audio sources to device with Optical IN capability.

1. Connect an optical cable from the DIGITAL OUT to the OPTICAL IN of a separate Stereo System Amplifier as shown on the Rear Panel on the right.
2. Connect an RCA stereo cable from the AUDIO OUT to the Audio input of a separate Stereo System Amplifier as shown on the Rear Panel on the right.

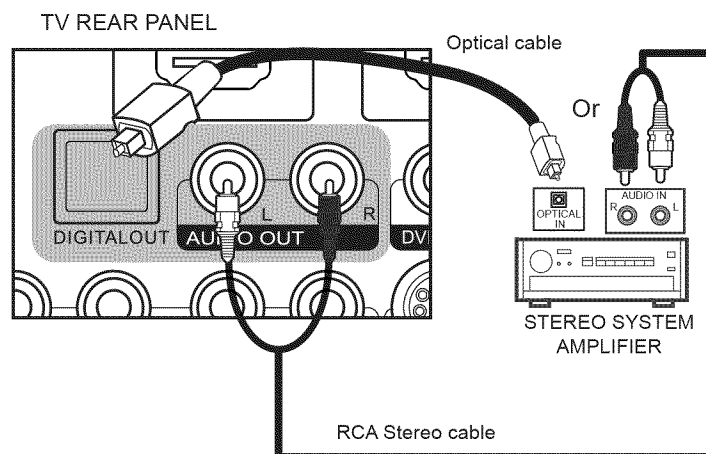

### NOTES

- Completely insert the connection cord plugs when connecting to rear panel jacks. If you do not, the picture and/or sound may be abnormal.
- Cable plugs are often color-coded. Match colors of plugs and jacks, i.e. connect red to red, white to white, etc.
- To return to the last channel viewed, select "0.TV" from the INPUTS menu.

# The Remote Control

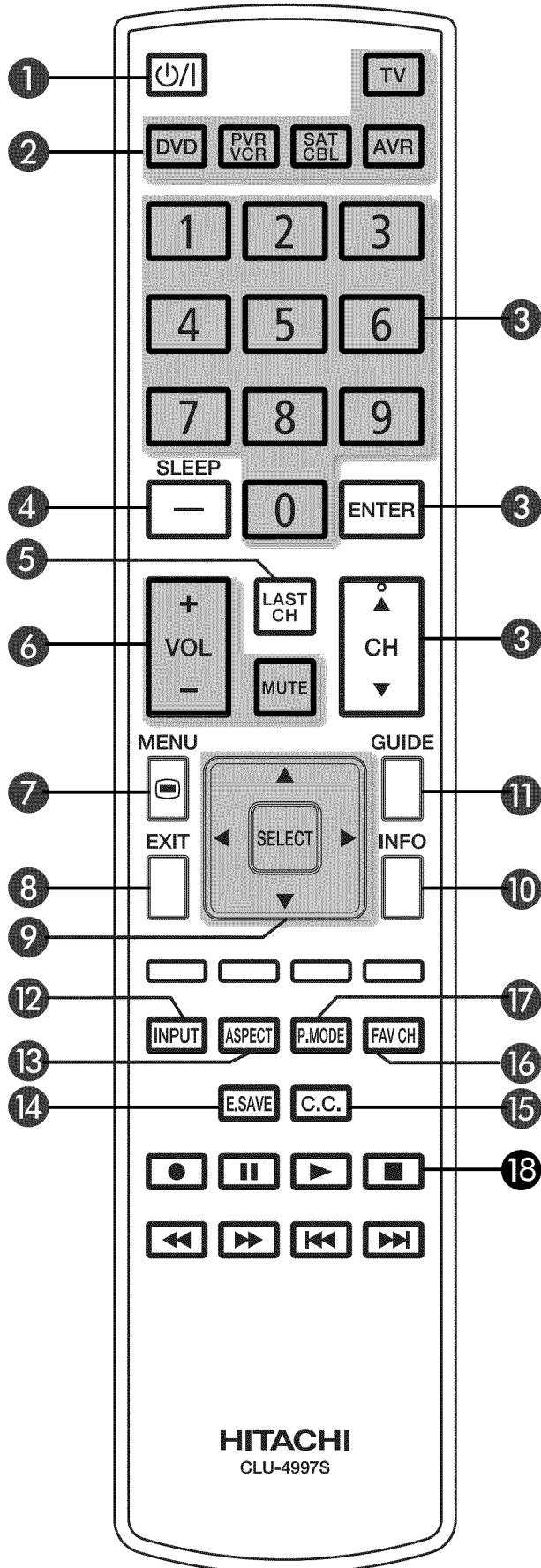

## 1 POWER Button

Press this button to turn the TV set on or off.

## 2 DEVICE Buttons

In addition to controlling all the functions on your Hitachi LCD TV, the new remote control is designed to operate different types of VCRs, cable boxes, set top boxes, satellite receivers, DVD players, and other audio/video device with one touch. Basic operation buttons are grouped together in one area.

To operate your LCD TV, select TV by pressing the TV button on the remote control. The TV mode indicator will blink, indicating that the remote will now control your television.

Repeat the same procedure for other devices. Press the DVD button for DVD players, press the PVR/VCR button for personal video recorders, press the SAT/CBL button for satellite/cable boxes, and press the AVR button for audio video receivers.

See pages 22~27 for instructions on how to program the remote control to control your device.

## 3 CHANNEL SELECTOR/ENTER Buttons

The CHANNEL SELECTOR buttons are used to select channels, lock access code, etc. Use the CHANNEL SELECTOR buttons to enter one, two, or three numbers to select channels. Enter 0 first for channels 1 to 9, or simply press the single digit channel you wish to tune, then press the ENTER button for the TV to tune. Channel selection may also be performed by CHANNEL (CH) UP (▲) or CHANNEL (CH) DOWN (▼).

## 4 (-) DASH/SLEEP Button

Use the (-) DASH button with the CHANNEL SELECTOR buttons to enter Digital Channels that have subchannel numbers indicated by (-) DASH (example 15-1). Also press to Set the Sleep Timer from 5 minutes to 4 hours.

## 5 LAST CHANNEL Button

Press this button to toggle between the current and last channel viewed.

## 6 VOLUME (VOL), MUTE Button

Press the VOLUME button (+ or -) until you obtain the desired sound level.

Press the MUTE button to turn the sound off completely (MUTE). To restore the sound, press the MUTE button one more time, or VOL UP (+).

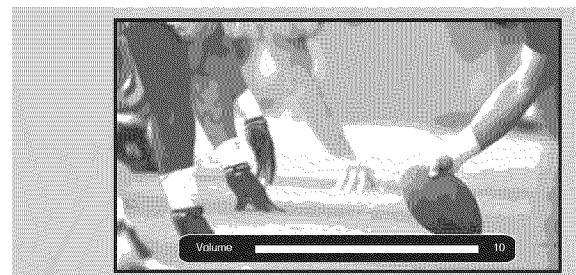

# How To Use The Remote Control To Control Your TV

Closed Captioning will display automatically when MUTE is on and Closed Caption is set to With Mute (see page 37). When the TV power is turned off at a volume level 21 or greater, the volume level will default to 20 when the TV is turned on. However, if it is set to a level 20 or less, the volume level will be at the level it was set when the TV was turned off.

## 7 MENU Button

The MENU button will start the On-Screen Display.

## 8 EXIT Button

This button will exit all On-Screen Displays.

## 9 CURSOR PAD/SELECT Button

All the On-Screen Display features can be set or adjusted by using the CURSOR PAD and the SELECT button, except for numeric entries. Press the CURSOR PAD toward desired direction and press the SELECT button to select.

## 10 INFO Button

Press this button when you want to check the channel being received, the picture source, if the channel has stereo (ST) or second audio program (SAP), the time, and CHANNEL ID.

## 11 GUIDE Button

Press this button to access the Channel Guide of your Satellite receiver, set top box or cable box while in SAT/CBL mode.

## 12 INPUT Button

Press this button to access the INPUTS menu. Use the CURSOR PAD and SELECT buttons to select the desired input. Pressing the INPUT button repeatedly will also cycle through the inputs that are available. Then press the SELECT button or wait 4 seconds to automatically select the highlighted input.

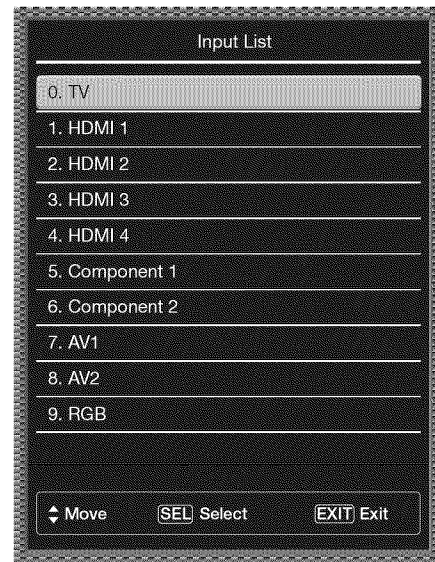
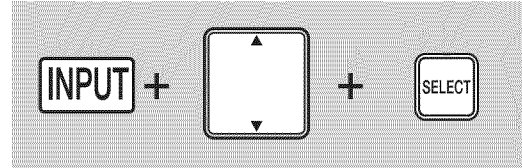

### ANALOG CHANNELS

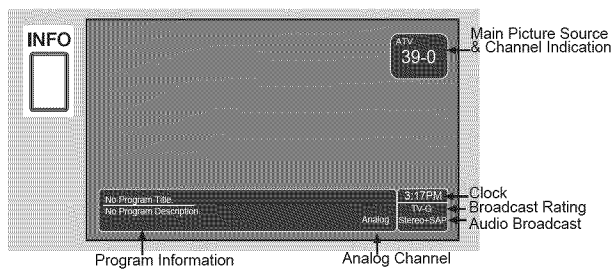

### DIGITAL CHANNELS

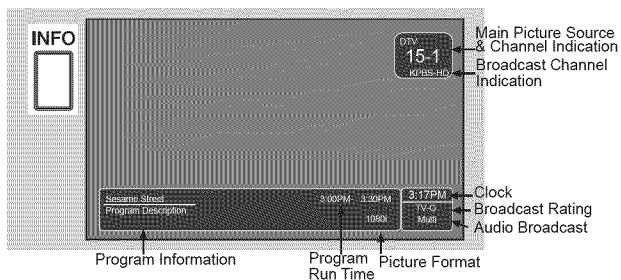

### VIDEO INPUTS

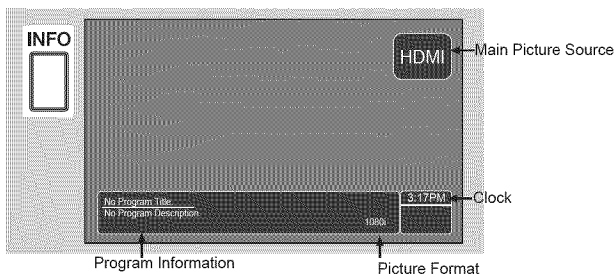

- |                |                                       |
|----------------|---------------------------------------|
| 0. TV          | Watch TV from an Air or Cable signal. |
| 1. HDMI 1      | Select to choose HDMI 1 Input.        |
| 2. HDMI 2      | Select to choose HDMI 2 Input.        |
| 3. HDMI 3      | Select to choose HDMI 3 Input.        |
| 4. HDMI 4      | Select to choose HDMI 4 Input.        |
| 5. Component 1 | Select to choose Component Input 1.   |
| 6. Component 2 | Select to choose Component Input 2.   |
| 7. AV 1        | Select to choose AV1 Input.           |
| 8. AV 2        | Select to choose AV2 Input.           |
| 9. RGB         | Select to choose PC input             |

### NOTE

The inputs that do not have any device connected to them will be unavailable (grayed out). Depending on the device, it may be required to turn on the device for the TV to recognize it is available. You can access these grayed-out inputs by using the CURSOR PAD or NUMERIC buttons on the remote control.

### NOTES

- Press the INFO button again or the EXIT button to return to normal viewing.
- The Aspect INFO will not be shown when the INFO is pressed.

# How To Use The Remote Control To Control Your TV

## 13 ASPECT Button

Press this button to quickly change the picture format ASPECT ratio. Depending on the input picture format, ASPECT allows you to adjust the image through the following options.

### Auto

Use this aspect mode to have the aspect mode change automatically by signal detector.

### 4:3

Use this aspect mode to display conventional (4:3) images. Side panels (black areas) are placed to the left and right of the image to preserve the original aspect ratio of the source.

### 16:9

Use this aspect mode to display 16:9 sources like HDTV and DVD's preserving the original 16:9 aspect ratio showing 95% of the size.

### Full

Use this aspect mode to display 16:9 sources like HDTV and DVD's preserving the original 16:9 aspect ratio showing 100% of the size.

### Zoom1/Zoom2

Use these aspect modes to zoom in and to reduce the black bars.

- AIR/CABLE - Analog Signal
- AIR/CABLE - Digital Signal
- COMPONENT

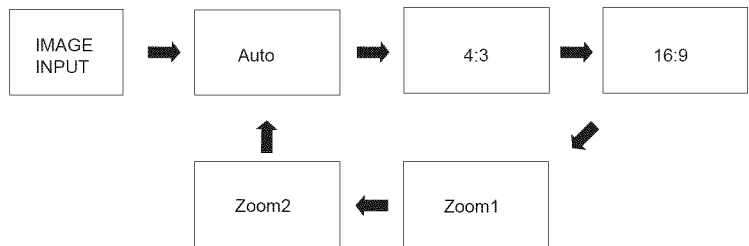

- AV

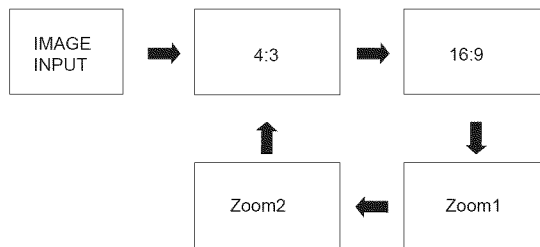

- HDMI - VGA
- DVI - VGA
- RGB

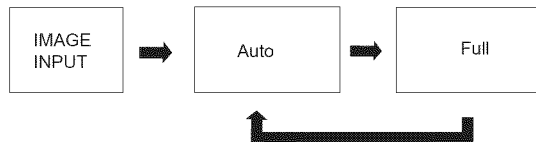

- HDMI - 1080p/1080i/720p/480p/480i
- DVI - 1080p/1080i/720p/480p/480i

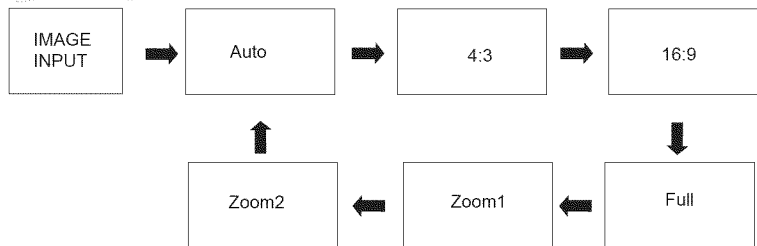

## NOTES



- Each input has memory for the Aspect setting. Changing the aspect on one input will not affect the aspect settings on other inputs.
- When displaying "Full" you may notice noise at the top of the picture. Select the "16:9" aspect mode to remove the noise. The noise is normal for some signals.
- See page 55 for Aspect availability according to signal format in use.

# How To Use The Remote Control To Control Your TV

## 14 ENERGY SAVE (E.SAVE) Button

Use this button to choose power consumption reduction settings based on 3 levels (Min, Medium, Max). See page 37 for further details.

## 15 CLOSED CAPTIONS (C.C.) Button

Use this button to display the dialogue, narration, and/or sound effects of a television program or home video which are displayed on the TV screen when available. Your local TV program guide denotes these programs as  or .

## 16 FAVORITE CHANNEL (FAV CH) Button

Press the FAV CH button to display the Favorite CH List. You have to first setup the Favorite Channels in the Channels Menu in order display the list. Press the FAV CH button on the remote control to display the list and select the desired channel using the CURSOR PAD and then press SELECT button to view.

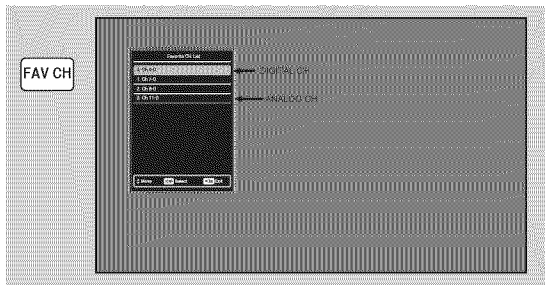

## 17 PICTURE MODE (P.MODE) Button

Press this button to toggle between Dynamic, Standard, Movie, Custom, Game, Pro-Day and Pro-Night picture mode settings. Select Dynamic mode for automatic brightness and contrast adjustment. Select Standard mode for day time viewing with more brightness and contrast to compete with room light. Select Movie mode for viewing with less brightness and contrast for a more detailed picture. Select Custom mode for viewing with your own brightness and contrast picture settings. Game mode is for automatic brightness and contrast adjustment when playing video games. Pro modes are for your custom calibration settings. (see page 30 for setting changes).

## 18

### DEVICE CONTROL Buttons

These buttons can control external devices (i.e. PVR/VCR, DVD, etc.) directly depending on the device mode set on the remote control. Also, these buttons are for controlling devices with Consumer Electronics Control (CEC) through the HDMI connection like Blu-Ray or DVD players, PRV, set top box while in TV mode.

### NOTE

*For some devices, these buttons are not available to control through the TV and HDMI connection; please refer to the device's owners guide for more information.*

# How To Use The Remote Control To Control Your AV Device

## OPERATING THE PRECODED FUNCTIONS FOR YOUR AV DEVICE.

The new remote control is designed to operate different types of VCRs, cable boxes, set top boxes, satellite receivers, DVD players, and other audio/video device. You must first program the remote control to match the remote control system of your AV device (refer to pages 26~27 for a preprogrammed code number).

### AV DEVICE CONTROL SETUP PROCEDURE

1. Turn on your AV device.
2. Select the desired mode: DVD, PVR/VCR, SAT/CBL or AVR by pressing the corresponding button.
3. Hold down the device button (DVD, PVR/VCR, SAT/CBL or AVR) on the remote control and enter the four digit preset code that matches your device as shown on pages 26~27.
4. Release the device button.
5. If done correctly, the device LED indicator will blink 3 times to confirm proper setup.
6. The remote control will now control the desired device.

### SETUP EXAMPLE (Hitachi Cable Box with precode 0003)

1. Turn ON your Cable box.
2. Select cable mode by using your SAT/CBL button to position the LED indicator on SAT/CBL.
3. Hold down the SAT/CBL button on the remote control and press the numbers 0, 0, 0 and 3.
4. Release the SAT/CBL button.
5. The indicator light will flash 3 times if the code was accepted.
6. Aim the remote control at the cable box and press the POWER button. The remote control will turn off your cable box when the correct four digit preset code is entered. When this occurs, the remote control is programmed for your cable box. If the cable box does not turn off, try a different four digit preset code.
7. The remote control will now control your cable box.

Repeat the same procedure for your set top box or satellite receiver (select SAT/CBL), your DVD (select DVD), your VCR/PVR(select VCR/PVR), or your AVR (select AVR).

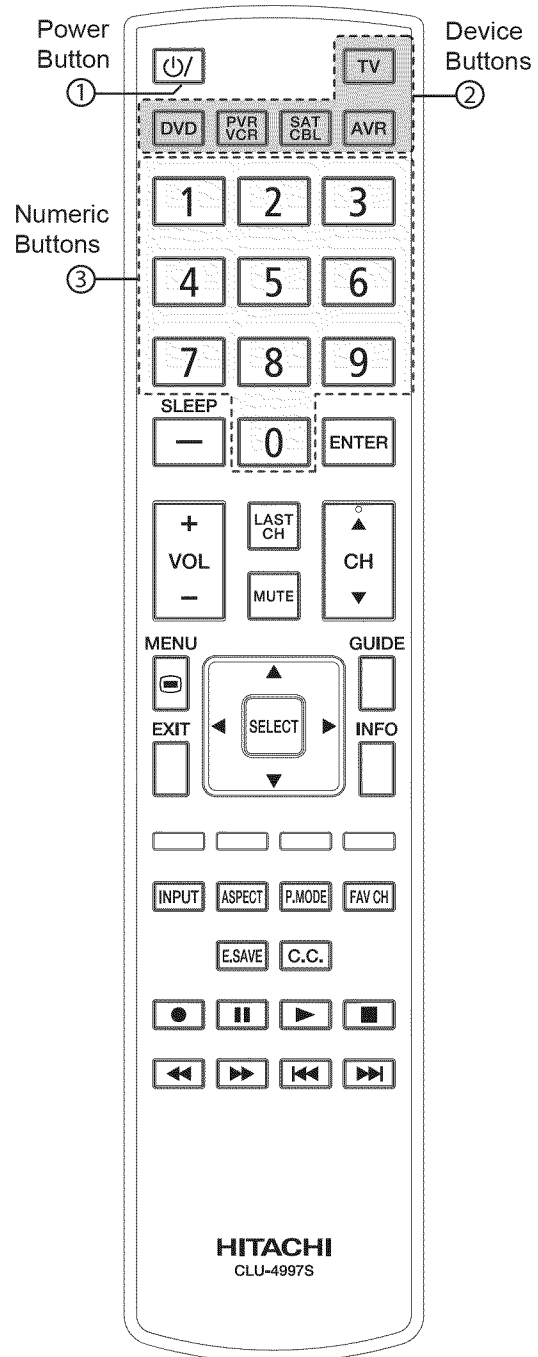

### NOTES

- If your AV device cannot be operated after performing the above procedures, your AV device code has not been preprogrammed into the remote control.
- In the unlikely event that your AV device cannot be operated after performing the above procedures, please consult your AV device owners guide.
- The remote control will remember the codes you have programmed even after the batteries are removed from the remote control. To reset all programmed codes to factory default place remote control in TV mode, then press and hold TV mode button and enter "9", "8", "1" in sequence.

# How To Use The Remote Control To Control Your AV Device

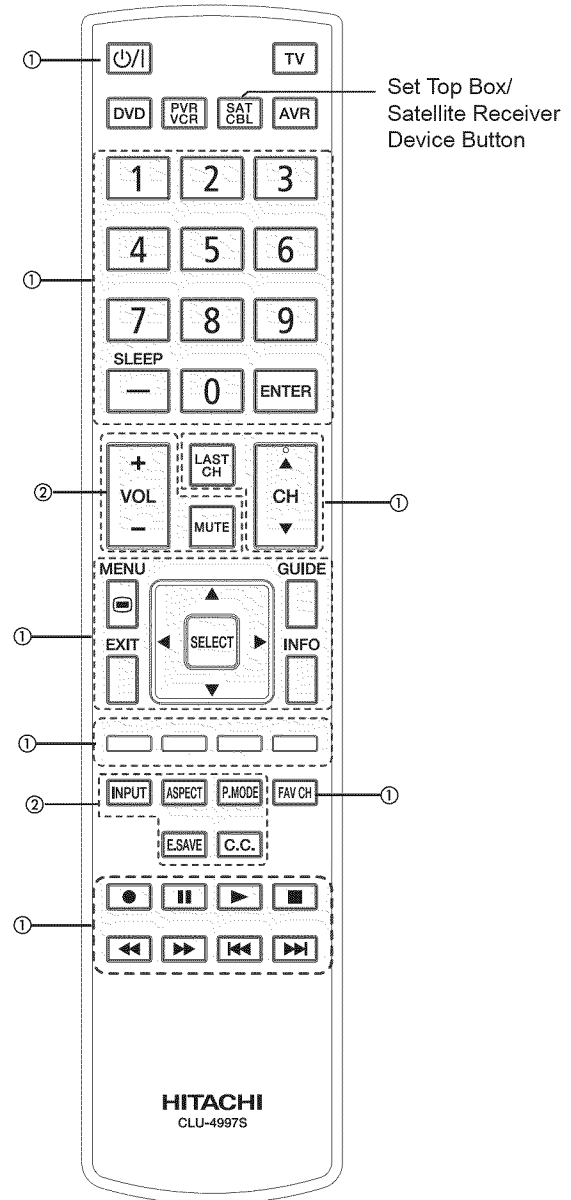
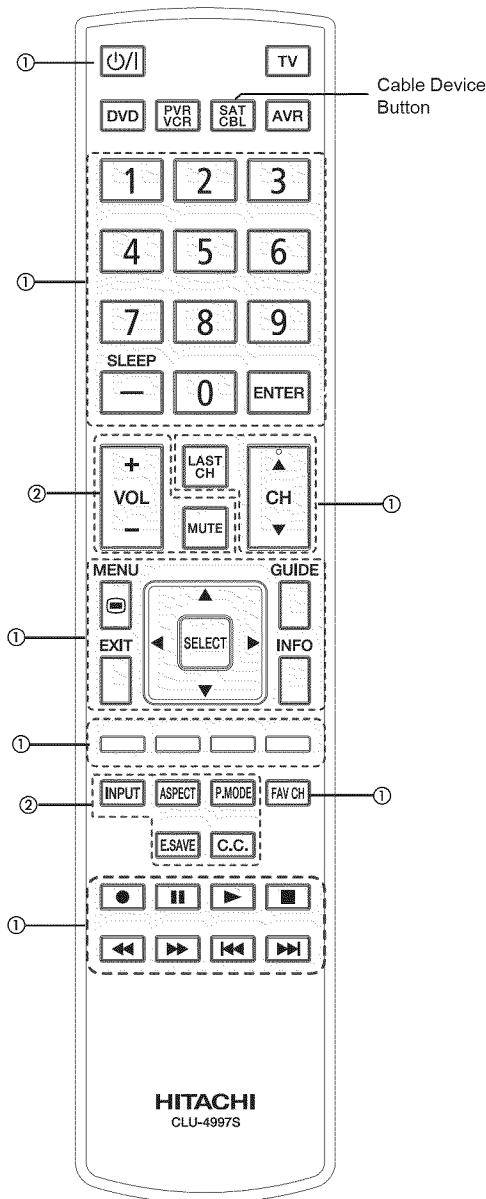

REMOTE CONTROL

**MY CABLE BOX CODE IS:** \_\_\_\_\_

**MY SET TOP BOX/SATELLITE RECEIVER CODE IS:** \_\_\_\_\_

**NOTE** Refer to the instruction manual of the cable box for operation of the buttons exclusively for the cable box.

**NOTE** Refer to the instruction manual of the Set Top Box/Satellite Receiver for operation of the buttons exclusively for the Set Top Box/Satellite Receiver.

- ① **PRECODED CABLE BOX Buttons**  
 These buttons transmit the chosen precoded cable codes :
- Power
  - Cursor & Select
  - Number PAD
  - Menu
  - Info
  - Enter
  - Exit
  - Channel Up & Down
  - Dash (-)
  - Guide
  - Last CH
  - Fav CH
  - Play, Stop, Pause, RWD, FWD, Skip
  - Color Buttons
  - FWD, Skip RWD, Record.

- ① **PRECODED SET TOP BOX/SATELLITE Buttons**  
 These buttons transmit the chosen precoded Set Top Box/Satellite Receiver codes :
- Power
  - Cursor & Select
  - Number PAD
  - Menu
  - Info
  - Enter
  - Exit
  - Channel Up & Down
  - Dash (-)
  - Guide
  - Last CH
  - Fav CH
  - Play, Stop, Pause, RWD, FWD, Skip
  - Color Buttons
  - FWD, Skip RWD, Record.

- ② **EXCLUSIVE TV Buttons**  
 These buttons are for operating the TV :
- P. Mode
  - CC
  - Input
  - Aspect
  - Vol Up & Down
  - Mute
  - E. Save

- ② **EXCLUSIVE TV Buttons**  
 These buttons are for operating the TV :
- P. Mode
  - CC
  - Input
  - Aspect
  - Vol Up & Down
  - Mute
  - E. Save

# How To Use The Remote Control To Control Your AV Device

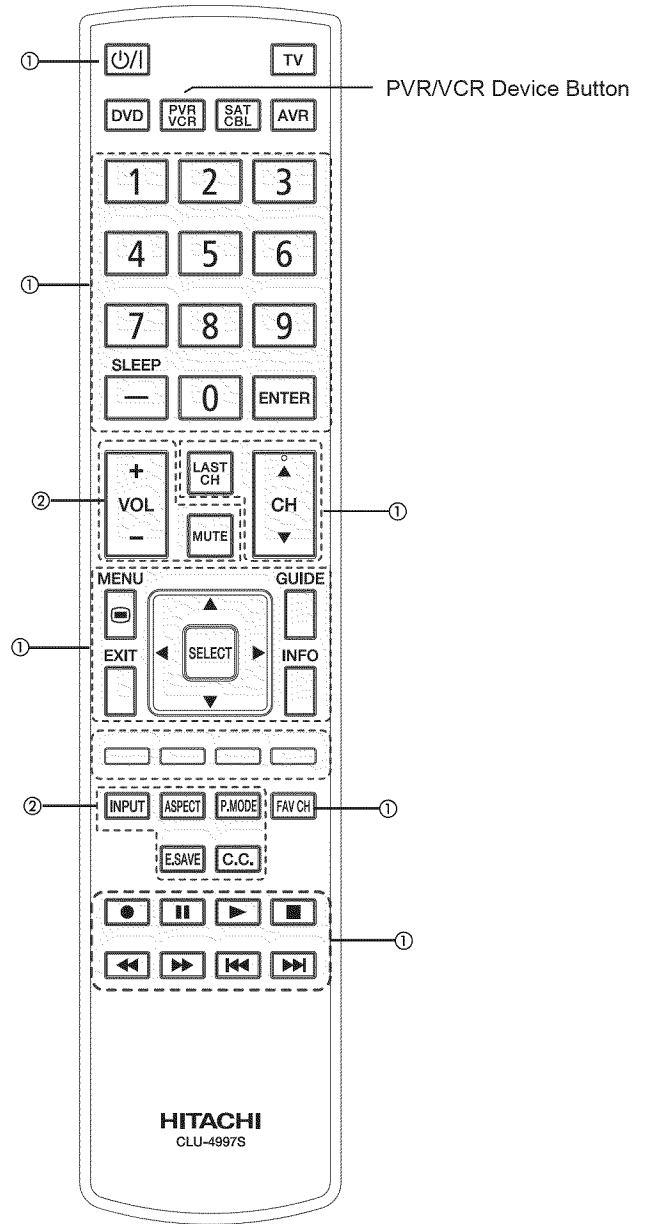
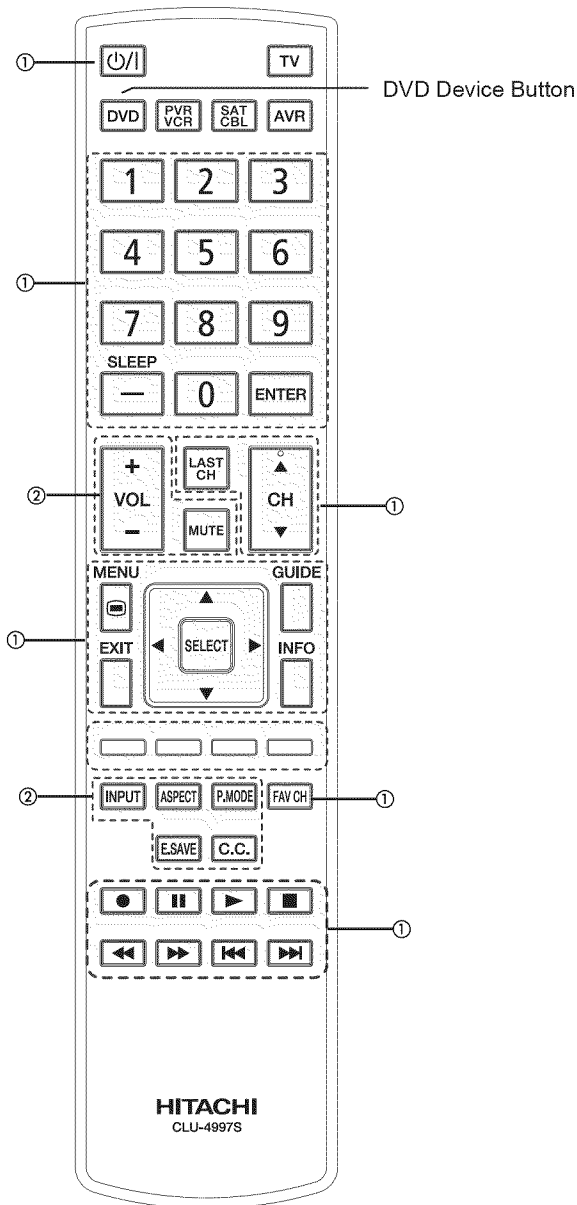

**MY DVD PLAYER CODE IS:** \_\_\_\_\_

**MY VCR/PVR CODE IS:** \_\_\_\_\_

**NOTE** Refer to the instruction manual of the DVD Player for operation of the buttons exclusively for the DVD Player.

**NOTE** Refer to the instruction manual of the PVR/VCR for operation of the buttons exclusively for the PVR/VCR.

- ① **PRECODED DVD Buttons**  
 These buttons transmit the chosen precoded DVD codes :
- |                  |                    |  |
|------------------|--------------------|--|
| -Power           | -Number PAD        | -Play, Stop, Pause, RWD, FWD, Skip FWD, Skip FWD |
| -Menu            | -Info              |  |
| -Cursor & Select | -Channel Up & Down |  |
| -Exit            |                    | -Record  |
| -Dash            | -Enter             | Guide  |

- ① **PRECODED VCR/PVR Buttons**  
 These buttons transmit the chosen precoded VCR/PVR codes :
- |                        |                    |                                   |
|------------------------|--------------------|-----------------------------------|
| -Power                 | -Cursor & Select   | -Enter                            |
| -Menu                  | -Channel Up & Down | -Dash(-)                          |
| -Exit                  | -Number PAD        | -Play, Pause, Stop, FWD, Skip FWD |
| -Info                  | -Last CH           |                                   |
| -Record                | -RWD, Skip RWD     |                                   |
| -FAV CH (Only for VCR) |                    |                                   |

- ② **EXCLUSIVE TV Buttons**  
 These buttons are for operating the TV :
- |          |                |        |
|----------|----------------|--------|
| -P. Mode | -CC            | -Input |
| -Aspect  | -Vol Up & Down | -Mute  |
| -E. Save |                |        |

- ② **EXCLUSIVE TV Buttons**  
 These buttons are for operating the TV :
- |          |                |        |
|----------|----------------|--------|
| -P. Mode | -CC            | -Input |
| -Aspect  | -Vol Up & Down | -Mute  |
| -E.Save  |                |        |



# How To Use The Remote Control To Control Your AV Device

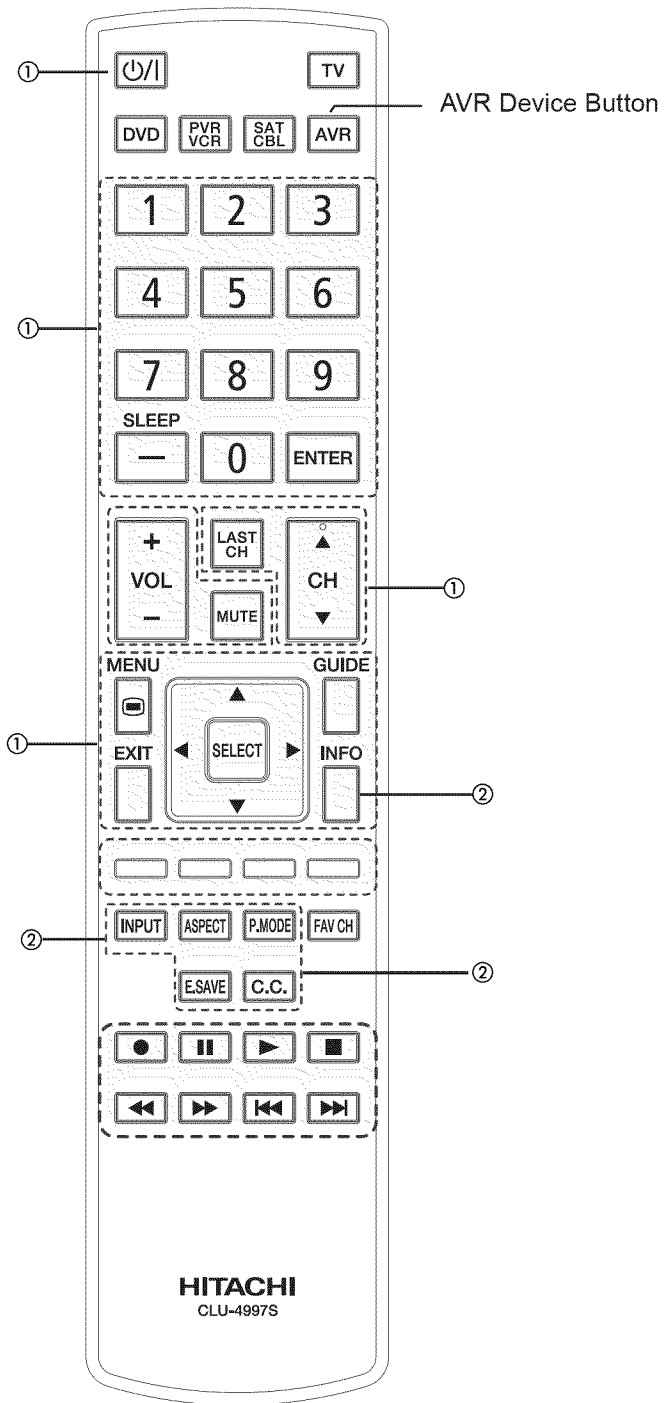

## MY AUDIO/VIDEO RECEIVER (AVR)

CODE IS: \_\_\_\_\_

### NOTE

Refer to the instruction manual of the AVR for operation of the buttons exclusively for the AVR.

### ① PRECODED AVR Buttons

These buttons transmit the chosen precoded AVR codes :

- Power
- Cursor & Select
- Vol Up & Down
- Menu
- Channel Up & Down
- Mute
- Exit
- Number PAD
- Play, Pause, Stop, RWD, Skip RWD, FWD, Skip FWD,
- Input
- Record
- Enter

### ② EXCLUSIVE TV Buttons

These buttons are for operating the TV :

- P. Mode
- CC
- Aspect
- E.Save
- Info



# Remote Control Codes

WARDS	0060,0035,0037 0048,0047,0081 0033,0240,0045 0000,0042,0043 0041,0072,0038 0479,0065,0046 0000,0209,0072 0278,0479	AMPHION 0872 MEDIA WORKS AMW 0872 APEX DIGITAL 0533,0672,1020 1056,1061	LITEON 1058,1158,1416 1440 0741 0783 0675 0503,0539,0646 0675,1354,1506 1159	VOCOPRO 1360 XBOX 0522,2083 YAMAHA 0490,0539,0545 0497 0872 0503,0591,0741	RCA 1023,1609,1390 REALISTIC 1609,0121 REVOX 0189 SAMSUNG 1304,1500,1868 SANGEAN 2165 SANSUI 1189,0189 SHERWOOD 1913 SIRIUS 1602,1811 SONY 1058,1441,1258 1759,1622,1406 1558,1658,1758 1858		
WHITE WESTINGHOUSE WORLD XR-100 YAMAHA ZENITH	0035,0240,0000 0072 0041,0038 0037,0039,0033 0000,0209,0041 0278,0479,1139 1972	ARRGO 1023 ASPIRE 1168 DIGITAL AUDIOVOX 0790 AWA 0730 B & K 0655,0662 BBK 1224 BEL CANTO 1571 DESIGN BLUE PARADE 0571 BLUE SKY 0695 BROKSONIC 0695 CALIFORNIA 0490 AUDIO LABS CELESTIAL 1020 CENTREX 0672 CINEA 0831 CINEVISION 0876,0833,0869 CITIZEN 1003,0695,1277 1587,2116 CLAIRTONE 0571 COBY 0778,0852,1077 1086,1107,1165 1177,1351 CRAIG 0831 CREATIVE 0503,0539 CURTIS MATHES CYBERHOME 0816,0874,1023 1024,1129,1502 1537 CYTRON 0705 DAEWOO 0784,0705,0770 0833,0869,1169 1172,1234,1242 DANSAI 0770 DAYTEK 0872 DECCA 0770 DENON 0490,0634 DENVER 0778 DIGITREX 0672 DISNEY 0675,1270 DI VIDO 0705 DUAL 0675 DURABRAND 1127 DVD2000 0521 EMERSON 1003,2116 ENTERPRISE 0591,0675 ENTIVO 0503,0539 ENZER 0770 FISHER 1919 FUNAI 0675 GATEWAY 1073,1077,1158 GE 0522,0815 GO VIDEO 0573,0744,0715 0741,0783,0833 0869,1044,1075 1099,1144,1158 1304,1730 0741,0869 GOLDSTAR 0790 GOODMANS 0790 GPX 0769 GRADIENTE 0490 GRUNDIG 0539,0705 HARMAN/ KARDON 0582,0702 HELLO KITTY 0831 HITACHI 0573,0664,1919 HITEKER 0672 INSIGNIA 2095 INTEGRA 0571,0627 IRT 0783 JBL 0702 JMB 0695 JSI 1423 JVC 0558,0623,0867 1164 1049,1051 JWIN 0790 KAWASAKI 0490,0534 KENWOOD 0790,1020,1149 0533 KLOSS 0711,0721 KONKA 0769,1061,1423 KOSS 0627 LASONIC 1533 LECSON 1127 LENOMX 0591,0741,0869 LG	MALATA MARANTZ 0503,0539,0646 0675,1354,1506 0675,1354,1506 MCINTOSH MCMOREX 0695,0831,1270 2213 MICROSOFT 0522,2083 MINATO 0752 MITSUBISHI 1521,0521 MUSTEK 0730 MYRAD 0894 NAD 0741 0770 NAIKO 0785,0869 NEC 1402 NEXXTECH 1051 NINTAUS 1003,0872,1107 1265 ONKYO 0503,0827,1769 OPPO 0575,1224,1525 2185 0571 OPTIMUS 0672,0852 PALSONIC 0503,0490,0571 PANASONIC 0703,1641,1762 0675 PHILCO 0503,0539,0646 PHILIPS 0675,1267,1340 1354,2056,2084 1024 PIANODISC 0525,0571,0142 PIONEER 0631,1571 1020,1061,1086 0539 POLAROID 0770 POLK AUDIO 0675 PORTLAND 2126,2127 PRESIDIAN 0672 PRIMA 0522 PROCEED 0778 PROSCAN 0741 PROVISION 0571 RADIONETTE 0522,0571,0790 RADIO SHACK 1919 RCA 0822,1769 0571 REALISTIC 0752 REOC 0869 RIO 1360 RJTECH 0623,1178 ROTEL 0698,0752 SAMPO 0490,0573,0744 SAMSUNG 0199,0820,1044 1075,2069 0695 SANSUI 0675,0695,0873 SANYO 1919 SCHNEIDER 0783 SCHWAIGER 0752 SENSORY SCIENCE 1158 SHARP 0630,0675,0752 1256 SHERWOOD 0633,0770,1043 1077 SHINSONIC 0533 SLIM ART 0784 SM ELECTRONIC 0730 SONIC BLUE 0573,0715,0783 0869,1099 SONY 0533,1533,0864 1033,1070,1431 1516,1536 0675 SYLVANIA 0675 SYMPHONIC 0894 TAG MCLAREN 0770 TATUNG 0571,0790 TECHNICS 0490,0703 TECHNIKA 0770 TECHSONIC 0730 THETA DIGITAL 0571 THOMSON 0522 TIVO 1503 TOSHIBA 0503,0573,0539 0695,1154,1503 1608,1769 0800,0803 TREDEX 0770 UNIMAX 0730 UNITED 0730 UNIVERSUM 0591 URBAN CONCEPTS 0503,0539 V 1064,1226 VENTURER 0790 VIZIO 1064,1226	GO VIDEO 1730 PANASONIC 0490 PHILIPS 1340 PIONEER 0631 RCA 0522 SHARP 1256 SONY 1033,1070,1536 SYLVANIA 0675 TOSHIBA 1503	ALCO 1405,0189,0121 AIVWA 1243,1388,1641 1390 1609 ANAM 1774 APEX DIGITAL 1189 ARCAM 1189 AUDIOTRONIC 1390 AUDIOVOX 0820,0840 B & K 0639,1253,1933 BOSE 1602 BRAUN 0189 CAIRN 1189,0189,0121 CARVER 0014 CURTIS MATHES 1414 DELPHI 1360,0121,1142 DENON 1306 ELECTROHOME 2026 GRUNDIG 0189 HARMAN/ 0189,0891,1304 KARDON 1306 HITACHI 0228 INSIGNIA 1030,2169 INTEGRA 0842,1298,1320 1805 JBL 1306 JVC 1058,1374,1495 1811 KAWASAKI 1390 KENWOOD 1570,1569 KLH 1390,1428 KOSS 1497 LG 2197 LINN 0189 LIQUID VIDEO 1497 MAGNAVOX 1189,1269,0189 1266,1514 MARANTZ 1189,1269,0189 0891 MICROMEGA 1189,0189 MITSUBISHI 1393 MYRAD 1189 NAKAMICHI 0097,1555 ONKYO 0842,1298,1320 1805 OPTIMUS 1023,0014,0121 0670 ORITRON 1497 PANASONIC 1308,1518,1288 1316,1548,1633 1763,1764,2967 PHILIPS 1189,1269,0189 0891,1266 PIONEER 1023,0014,0630 1384,1935 POLK AUDIO 1089,1414 RADIO SHACK 1609	SOUNDESIGN 0670 STEREOPHONICS 1023 TEAC 1390 TECHNICS 1308,1518,1633 THORENS 1189 TOSHIBA 0842,1788 VENTURER 1390 WARDS 0189,0014 XM 1406,1414 YAMAHA 1023,0176,1176 1276,1331,1815 2061	AUDIO AMPLIFIER Brand ADCOM 0577,1100 BOSE 0674 CARVER 0892 CARY AUDIO 1879 DESIGN CLASSE 1461 FLEXTRONICS 1879 HALCRO 1934 HARMAN/ KARDON 0892 KRELL 1837 LEFT COAST 0892 LEXICON 1145,1802 MARANTZ 0892 MARK LEVINSON 1483 PARASOUND 1934 PHILIPS 0892 POLK AUDIO 0892 PRIMARE 1395 YAMAHA 0354
<b>PVR Brand CODES</b>	ABS 1972 ALIENWARE 1972 CYBERPOWER 1972 DELL 1972 DIRECTV 0739 GATEWAY 1972 GO VIDEO 0614 HEWLETT PACKARD 1972 HOWARD COMPUTERS HP 1972 HUGHES NETWORK SYSTEMS 0739 HUMAX 0739,1797,1988 HUSH 1972 IBUYPOWER 192 LINKSYS 1972 MEDIA CENTER PC 1972 MICROSOFT 1972 MIND 1972 NIVEUS MEDIA 1972 NORTHGATE 1972 PANASONIC 0614,0616 PHILIPS 0618,0739 PIONEER 1337 RCA 0880 REPLAY TV 0614,0616 SAMSUNG 0739 SONIC BLUE 0614,0616 SONY 0636,1972 STACK 9 1972 SYSTEMAX 1972 TAGAR 1972 SYSTEMS TIVO 0618,0636,0739 1337 TOSHIBA 1008,1972,1988 TOUCH 1972 VIEWSONIC 1972 VOODOO 1972 ZT GROUP 1972	<b>DBS/PVR COMBO CODES</b> DIRECTV 0739 HUGHES NETWORK SYSTEMS 0739 PHILIPS 0739 SAMSUNG 0739 TIVO 0739 <b>DVD/PVR COMBO CODES</b> HUMAX 1797,1988 PIONEER 1337 RCA 0880 SYLVANIA 0000 TIVO 1337 TOSHIBA 1008,1988 <b>DVD Brand CODES</b> 3D LAB 0503,0539 ACCURIAN 0675,1416 ACOUSTIC SOLUTIONS 0730 ADCOM 1094 AFREEY 0898 AIWA 0641 AKAI 0695,0705,0770 1089 ALBA 0672 ALCO 0790 ALLEGRO 0869					

# On-Screen Display

1. Press MENU button on the remote control to display the different features on your Hitachi LCD TV.
2. Use the CURSOR PAD (▲, ▼, ◀ and ▶) and highlight a different feature of the On-Screen Display menu. Press the SELECT button to select.
3. Press EXIT button on the remote control to quickly exit from any menu.

MENU

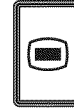

EXIT

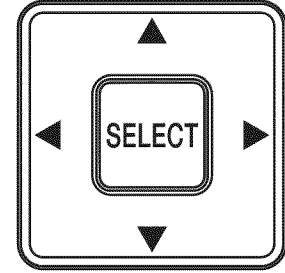
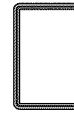

This part of the screen shows which selections are available.

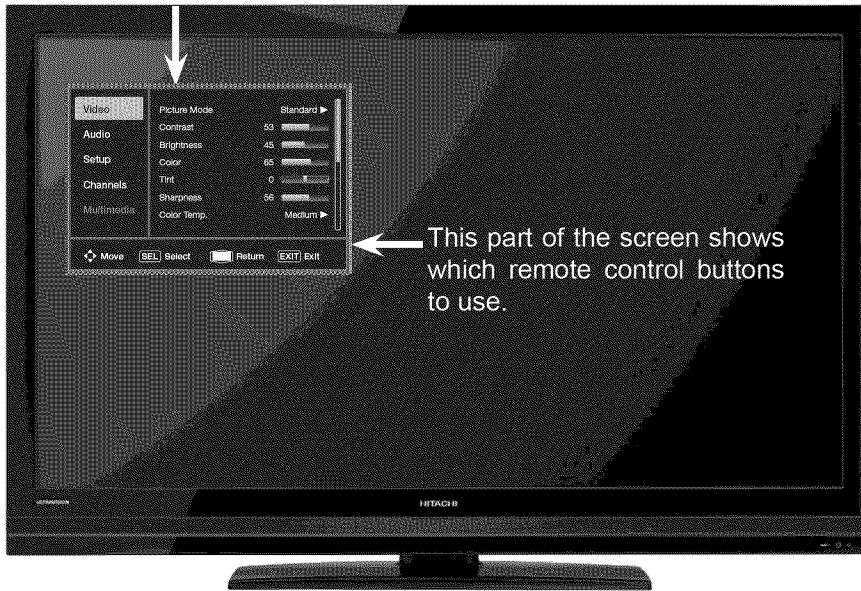

This part of the screen shows which remote control buttons to use.

## NOTE

The On Screen Display (OSD) for the different submenus shown in the following pages are for illustration purposes only, there may be slight differences from the actual appearance of the OSD of your Hitachi LCD TV.

## Video

**Picture Mode**

Select between 7 pictures modes; Dynamic, Standard, Movie, Custom, Game, Pro Day and Pro Night.

**Contrast**

Adjust picture contrast.

**Brightness**

Adjust picture brightness.

**Color**

Adjust color.

**Tint**

Adjust tint.

**Sharpness**

Adjust sharpness.

**Color Temp.**

Set this to High for less intense color with more blue, set to Medium for natural color and set to Standard for warm colors.

**Noise Reduction**

Reduces conspicuous noise in the picture.

**MPEG NR**

Reduces block noise in the picture.

**Gamma**

Changes the gamma ratio value to produce pictures of greater contrast.

**Backlight**

Adjust to increase or decrease the brightness of backlight.

**Auto Movie**

Select the 3:2 Pull down detection feature Auto/Off. For a film like picture.

**Reel120 Motion**

Adjust the movie motion to smooth or original.

**Aspect Ratio**

Choose the picture format aspect ratio.

**Reset**

Choose to Reset Video Settings to factory settings.

# On-Screen Display

## Audio

Sound Mode	Selects 4 audio presets (Custom, Standard, Movie, News).
Bass	Adjust the intensity of low frequencies.
Treble	Adjust the intensity of high frequencies.
Balance	Adjust the balance.
CONEQ	Select sound equalizing mode.
CONEQ 3D Sound	Select CONEQ 3D Sound settings (On, Off).
Audio Source	Select between three Audio Sources (Stereo, Mono, SAP).
Preferred Language	Select Language options if available (Available for digital channel).
Audio Language	Select Language options if available.
Digital Output	Select Optical Output options.
Internal Speakers	Turn On/Off internal speakers.
Perfect Volume	Adjust volume to be closer in level between channels.
Reset	Resets all Audio settings the original condition

**NOTE**

*The Audio Language and Digital Output of the Audio OSD are only available for Digital channels.*

## Setup

Menu Language	Choose English, French or Spanish OSD Language.
Time	Set Clock Settings.
Sleep Timer	Set Sleep Timer intervals (5 minutes ~ 4 hours).
Day/Night Timer	Set Day/Night picture mode to start at preset times.
Set Password	Set the password for the Parental control access and Calibration menu access.
Parental Controls	Ratings system to block various types of programs.
Closed Captions	Feature to turn On/Off closed captions.
Digital Captions	Feature to display Digital dialogue/text.
Digital Caption Options	Feature to change the appearance of the Digital Captions.
Analog Captions	Feature to display Analog dialogue/text.
Energy Options	Select Power Consumption Savings options.
Light Control	Set the brightness or turn Off the Power LED.
Transparency	Feature to change the OSD Menu transparency.
HDMI-CEC	Set to ON, this feature will enable simplified operation of compatible HDMI CEC devices.
Input Labels	Label Video Inputs, VCR, DVD, etc.
Component Options	Adjust the Phase and applies Reset to any adjustments made.
RGB Options	Adjust Horizontal Position, Vertical Position, Clock, Phase and Reset.
Reset AV & Setup	Resets all Audio, Video and Setup settings to the original condition.

## Channels

Source	Selects the type of signal to be used Cable or Air.
Signal Strength	Access Signal Strength meter.
New Channel Scan	Set Auto Channel Scan.
Add Channels to List	Adds Channels to the List (Scanned channels remain the same until New Channel Scan is performed).
Channel List	Set Channel List.
Channel Labels	Set Labels on the channels.
Favorite Channels	Set the Favorite Channels.

**NOTE**

*The Signal Strength feature of the Channels OSD is only available for Digital (DTV) channels.*

## Multimedia

JPEG Viewer	View digital still pictures from USB Drives.
-------------	--

**NOTE**

*If there are any options grayed out, this is an indicator that option is not available for that specific function or mode.*

**NOTE**

*Changing any Video/Audio settings, other than the Standard/Default settings, may not meet ENERGY STAR requirements.*

# Video

Select Video to adjust picture settings and improve picture quality. You can independently customize each of the video inputs, including Analog channels separately from Digital Channels (under TV Mode). Adjustments will be applied to Custom settings.

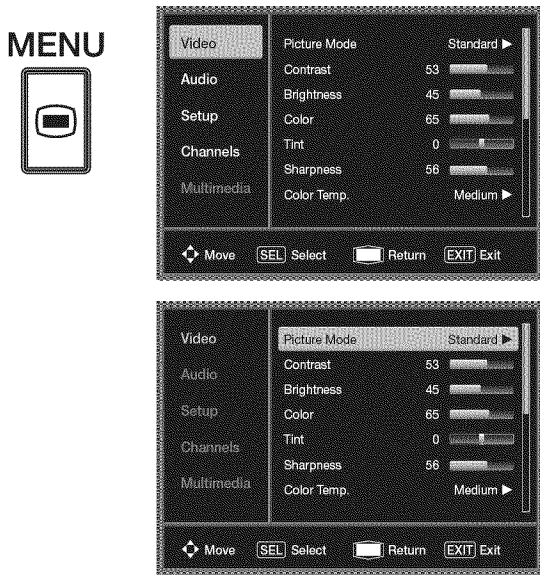

## Picture Mode

Use this function to choose from preset picture settings to optimize your TV's performance.

1. Use the CURSOR PAD ► to select Picture Mode settings (Dynamic, Standard, Movie, Custom, Game or Pro modes).
2. Then press the CURSOR PAD ◀ button to return to the Video menu or press the EXIT button to quit menu.
3. There are seven Picture Modes available: Dynamic, Standard, Movie, Custom, Game, Pro-Day, and Pro-Night Mode. Standard mode is the factory preset mode for your TV. The only mode that can be directly changed by adjusting any Video setting to your desired conditions is the Custom mode. The other modes, with the exception of the Pro-Day and Pro-Night (refer to Calibration Menu on page 30 for adjusting these modes), are preset. Any changes made to these modes will be applied to Custom mode.

### NOTES

- For the PC input, there are only two Picture modes available: Standard and Custom. In this case, only Custom can be changed to your desired conditions.
- Video Setting can be set to the user's preference in Game mode (Similar to Custom mode) with the exception of the Auto Movie setting.
- If you change any of the adjustments in the Dynamic, Standard and Movie modes, the name of the Custom option will change. For example, changes on Dynamic will rename the option as "Custom-Dyn.". This means that the original picture mode is not affected by the changes; the only thing affected is that Custom mode will take the video adjustments of the mode where the change was made.

## Pro Mode

This Hitachi LCD TV includes a picture quality mode called "Pro Mode" designed to customize the picture settings and is protected by a password in order to keep your settings as you want it. This option will give a couple extra picture modes (Pro-Day and Pro-Night) on your LCD TV for your viewing pleasure.

Please follow the next steps in order to adjust these special modes on your LCD TV.

1. Using the remote control, press the MENU button and select the Video menu by pressing the SELECT or ► button.
2. Use the CURSOR PAD ▼ to highlight the Picture Mode option, then press and hold the P.MODE button for 3 seconds, the Access Screen should appear.

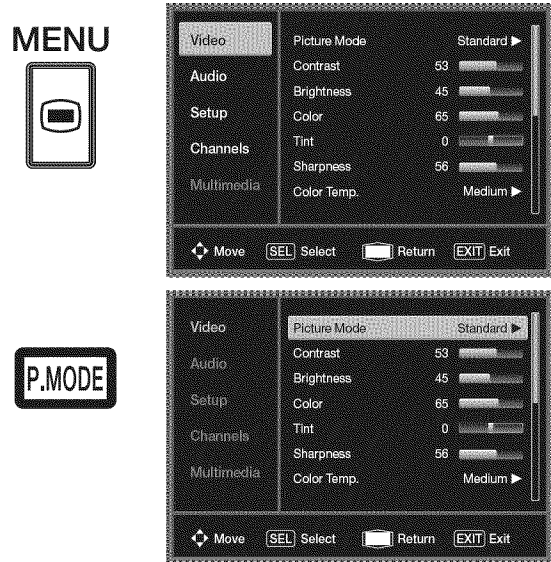

3. The code to enter the Pro Mode feature is a four digit access code. The factory preset code is 0000. Use the NUMERIC buttons on the remote control to enter the access code. After entering the correct access code, the Calibration Menu (green OSD) should appear and the picture mode changes to Pro Mode.

### NOTE

The password used to access the Pro Mode feature is the same password that is used to set and activate parental controls. To change this password please refer to the "Set the Password" Function on page 34.

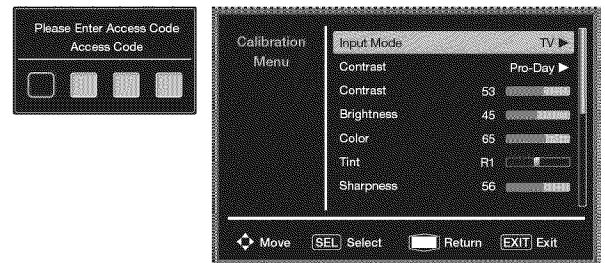

4. While in the Calibration menu, use the CURSOR PAD ▲, ▼ to highlight the desired function to be adjusted.
5. Press the SELECT button or the CURSOR PAD ► to select the function settings.
6. Press the CURSOR PAD ◀ or ► to adjust the function.
7. Press the MENU button to return to the Main menu or the EXIT button to quit the Calibration menu.

## Calibration Menu:

**White Balance:** Use this function to adjust the dark end (Cutoff) and bright end (drive) of the White background.

### NOTE

For Input Mode, CABLE and AIR share the same Video adjustment settings. Also, each of the video inputs have their own independent video adjustment settings.

# Video

## Other Video Menu Setting Adjustments

Use the CURSOR PAD ▲ or ▼ to highlight the function to be adjusted.

1. Press the SELECT button or the CURSOR PAD ► to select the function settings.
2. Press the CURSOR PAD ◀ or ▶ to adjust the function.
3. Press the MENU button to return to main menu.
4. Press the EXIT button to quit menu.

### Contrast

Use this function to change the contrast between black and white level in the picture.

### Brightness

Use this function to change the overall brightness of the dark areas of the picture.

### Color

Use this function to adjust the level of color in the picture.

### Tint

Use this function to adjust flesh tones so they appear natural.

### Sharpness

Use this function to adjust the amount of fine detail in the picture.

### Color Temp.

Set this to High for cooler color with more blue, set to Medium for a more natural color or set to Standard for accurate color.

### Noise Reduction

The Noise Reduction function automatically reduces conspicuous noise in the picture without degrading picture quality. Set Noise Reduction to Off if you see individual blocks in the picture.

### MPEG NR

The MPEG NR (Noise Reduction) function automatically reduces block noise in the picture without degrading picture quality.

### Gamma

The Gamma function allows you to set between three levels of gamma ratio correction values (Gamma 1, Gamma 2, or Gamma 3) to produce pictures contrast.

### Backlight

Adjust the brightness of the Backlight for maximum visibility. It changes the intensity of the backlight. Increase for bright rooms and decrease for darker rooms to make the dark areas of the picture black.

### Auto Movie

The Auto Movie function sets the 3:2 pull down detection feature to Auto or Off. Theatrical movies are shot on film at 24 frames or still pictures per second, instead of 30 frames or 60 fields like video. When film is transferred to video for television viewing, the disparity between the two frame rates must be reconciled. This involves a process known as 3:2 pull down. When Auto Movie is set to Auto your Hitachi LCD Television will activate the circuitry for this special feature to improve video performance when watching interlaced format film based sources. Set to Off to deactivate this feature.

### Reel120 Motion

Hitachi's advanced video processor can display movies at 120 frames per second. The following settings are available to smooth the motion of movie sources. Please note that the effect may not be immediately noticeable and the effect depends on the content of the movie.

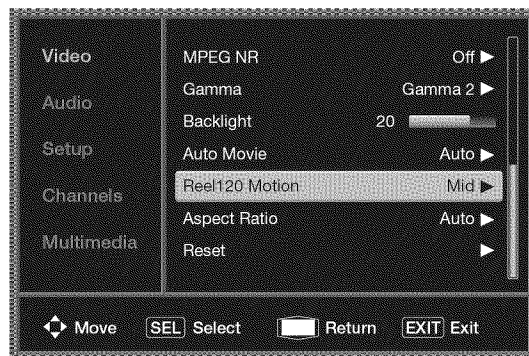

1. Use the CURSOR PAD ▲, ▼ to highlight Reel120 Motion function.
2. Press the CURSOR PAD ► to select Off, Low, Mid, or High.

**High:** Use this setting for the maximum smooth motion effect.

**Mid:** Use this setting for a moderate smooth motion effect.

**Low:** Use this setting for a mild smooth motion effect.

**Off:** Use this setting if there is noise with the High, Medium or Low settings.

### NOTE

Please note that the effect may not be immediately noticeable and the effect depends on the content of the movie.

## Aspect Ratio



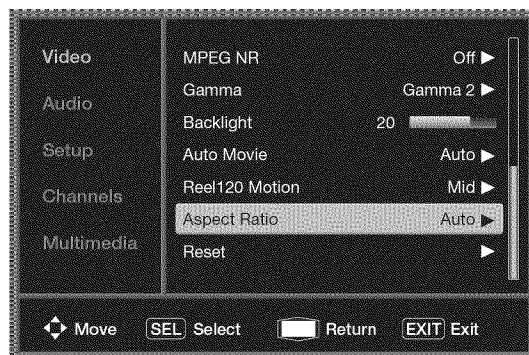

Use this function to select the Picture Format Aspect Ratio.

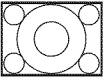
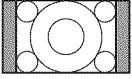
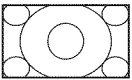

**Auto Aspect:** Automatically adjust the Aspect Ratio depending on the input signal.

**Aspect Modes:** Manually select the Aspect Ratio. There are different aspect ratios available according to the signal in use. See page 55.

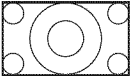
## Aspect Ratio reference

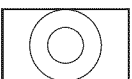
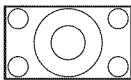
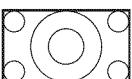
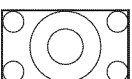
Input Signal	Display Screen	Display Aspect Recommended	To display suitable screen as follows.
When Watching Standard Definition Pictures:			
 (4:3 Signal)		4:3	Displays 4:3 programs in their original aspect ratio with bars to the left and right of the image.
		16:9	Expands a 4:3 aspect ratio program to fill the widescreen 16:9 screen
 (Vista)		Zoom1	Use this aspect mode to expand letterbox movies to fill the screen. Note that some of the image may not be visible.
 (Cinema)		Zoom2	Use this aspect mode to fill the screen with very widescreen movies. Note that some of the image may not be viewable in this mode.
When Watching High Definition Pictures:			
 (16:9 Signal)		16:9	Plays a 16:9 image faithfully showing 95% of the size.
		Full	Use this mode when you want to see 100% of the signal. Note that some signals have noise. In the case of noise use the 16:9 mode.

## Reset

This function allows you to reset the Video Menu Settings of the present input source and return it to the Standard video mode



1. Use the CURSOR PAD ▲ or ▼ to highlight this function.
2. Press the SELECT button or CURSOR PAD ► to select Yes or No.
3. Press the SELECT button on the Yes option to execute the reset of the Video settings.

Depending upon the video program being viewed, you can customize each video input to your preference to increase viewing performance and pleasure.

If you run this Reset menu, only the present input source will reset to its initial condition. For example, if the Reset menu has been selected and done for HDMI 1 input source, only the HDMI 1 settings will return to its factory default.



# Audio

Select Audio to adjust the sound to your preference.

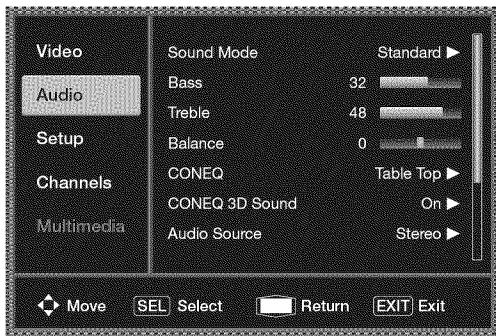

## Sound Mode

This function has four sound modes that are preset according to the type of program. Standard mode is for normal audio conditions, Movie mode is for movies, News mode is for News programs, and Custom mode is for adjusting audio levels to your preference. The only mode that can be directly changed by adjusting any audio setting to your desired conditions is the Custom mode. The other modes are preset and any changes made to these modes will be applied to Custom mode.

## Audio Menu Settings Adjustment

1. Press the CURSOR PAD ▲ or ▼ to select menu item.
2. Press the CURSOR PAD ◀ or ▶ to adjust the function.
3. Press the EXIT button to quit the menu, or select Audio to return to the main menu.

**NOTE** If Treble is selected you are adjusting treble. The additional menu items Bass and Balance can be selected and adjusted in the same manner.

## Bass

This function controls the low frequency audio to the speakers.

## Treble

This function controls the high frequency audio to the speakers.

## Balance

This function will control the left to right balance of the LCD TV internal speakers and headphone jack.

## CONEQ

Delivers clear crisp sound and high fidelity music playback. Use CURSOR ▶ to select the preferred setting.

**Table Top:** Use this setting for improved sound quality with table top stands.

**Wall Mount:** Select this setting for improved sound quality when wall mounting.

**Hearing Aid:** This special mode is for users that want to maintain clear sound after removing their conventional hearing aid. Note that this feature emphasizes higher frequencies.

## CONEQ 3D Sound

Produces a natural three-dimensional sound experience through the TV's sound system.

## Audio Source

Multi-Channel Television Sound will allow you to select Stereo (a stereo broadcast), Mono (monaural sound) used when receiving a weak stereo broadcast or SAP (Second Audio Program) which may be a secondary language, weather report, etc. This setting is only for analog programming.

## Preferred Language

Some programs transmit in other languages. This language function will allow you to set between 3 language options (English, Español and Français) to your preference as the audio default language.

## Audio Language

Some programs transmit more than one DTV language option. Most will have English as a default language. The language function will allow you to select up to 6 language options (if available). Please try all available options.

## Digital Output

This function allows you to select between RAW and PCM. This setting changes the format of the Digital Optical Output.

**PCM:** Select this feature if the TV is connected to an amplifier/receiver with a PCM only decoder; it will provide two independent soundtrack channels through the optical audio output jack (Digital Audio).

**RAW:** Select this feature to allow the original audio bit stream to be passed through to the audio receiver.

## Internal Speakers

This function is useful when using external speakers. Select On if using the internal speakers only. Select Off if you prefer to use the speakers from a separate stereo system.

## Perfect Volume

This function will automatically adjust volume so each channel and input has the same average volume level.

## Reset

This function allows you to reset the Audio Menu Settings of the present input source and return it to the Standard mode and default settings.

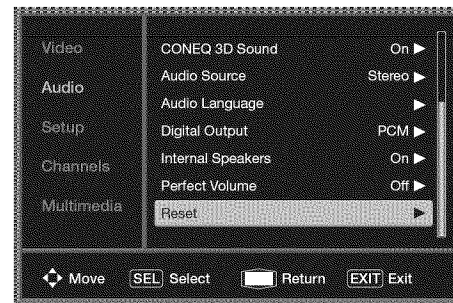

1. Use the CURSOR PAD ▲, ▼ to highlight functions.
2. Press the SELECT or the CURSOR PAD ▶ to select Yes or No.
3. Press the SELECT button on the Yes option to execute the reset of the Audio settings.

Depending upon the audio program being heard, you can customize each audio input to your preference to increase audio performance and pleasure.

All the input sources will be reset to its initial condition by running this Reset menu.

# Setup

Select Setup when setting your TV up for the first time.

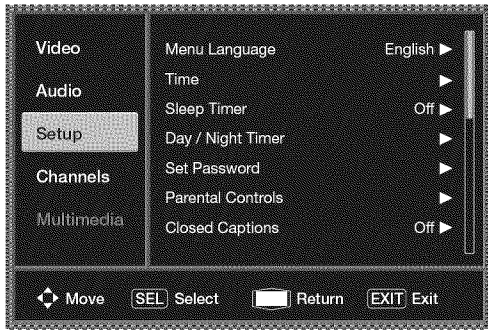

1. Use the CURSOR PAD ▲ or ▼ to select the Setup menu.
2. Use the CURSOR PAD ► to enter the option of your choice and make the changes that you need.
3. Press the MENU button to return.

## Menu Language

Sets the Language of the Menu OSD. This feature will allow you to select any one of three different languages for the on-screen displays.

1. Use the CURSOR PAD ► to select the language of your choice.
2. Press the EXIT button to quit the menu or the MENU to return to the previous menu.

## Time

Use this option to set the Clock, Date and Time Zone for your LCD TV.



1. Use the CURSOR PAD ▲, ▼, ►, ◀, to highlight and setup the Time settings.
2. If you observe daylight savings, use the CURSOR PAD to highlight Daylight Savings and press the ► button to activate it. This can only be changed if the Time Mode is set to Auto.
3. Use the CURSOR PAD to highlight and adjust the Current Time (hour and minute), AM or PM, Month, Day and Year.
4. Press the SELECT button to set the Time.
5. Press the EXIT button to quit the menu or the MENU to return to the previous menu.

### NOTES

- When Auto is set Daylight Savings can be set, the TV will automatically calculate the clock adjustment for Daylight Savings. Set this setting according to the current DST status.
- The TV counts electrical pulses for regulating the Timers. When the power cord is unplugged quickly, the clock will reset to factory default setting.
- The Year, Month, Date, and Time setup can be changed only if the Time Mode is set to Manual.

## Set Sleep Timer

Select this feature to set your Sleep Timer from 5 minutes to 4 hours.

1. Press the CURSOR PAD ► repeatedly to set your Timer from Off, 5 min, 10 min, 15 min, 30 min, 60 min, 90 min, 120 min, 180 min and 240 min.

## Day/Night Timer

Select this feature to activate and set your TV's Day/Night/Picture Mode Timers. There are three available Timers for your convenience.

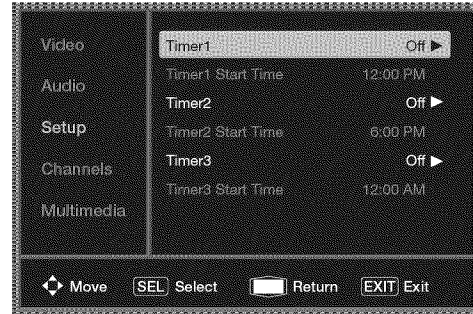

1. Use the CURSOR PAD to highlight the Timer that you would like to set (Timer1, Timer2, or Timer3).
2. Use the CURSOR PAD or SELECT button to select the Picture Mode you would like to activate. (Dynamic, Standard, Movie, Custom, Game, Pro-Day or Pro-Night).
3. Use the CURSOR PAD and select "Timer Start Time" and press Select.
4. Use the CURSOR PAD or NUMERIC buttons to set the timer start time.
5. Once the start time is set, press the SELECT button.
6. Repeat steps 1-6 to set another Timer.

## Set Password

1. To change the password, select Set the Password option to change the factory preset password (0000) to your preference. If you forget your password, use the factory password 7777 to erase your password. This will reset the access code number back to the factory preset (0000).
2. Enter a new four digit number.
3. Press EXIT button to quit the menu.

### NOTE

When setting the password, please take note that this password will also be common with the password used to access and set the Pro Mode/Calibration Menu features. For details about the Pro Mode/Calibration Menu, please refer to page 30.

# Setup

## Parental Controls

This function will block out the picture and sound of the selected rating levels.

The password to enter the Locks feature is a four digit number. The factory preset password is 0000. Use the NUMERIC buttons to enter the password.

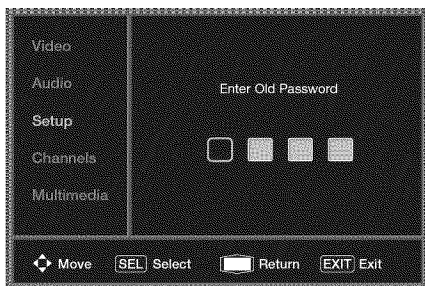
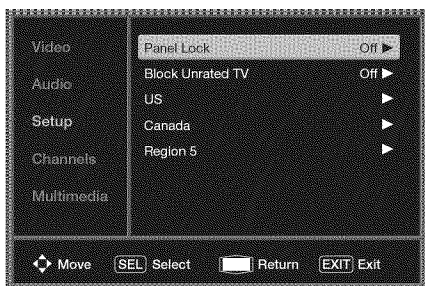

## Panel Lock

When Panel Lock is turned On, all buttons on the Side Panel, except the POWER button will be deactivated.

## Block Unrated TV

When this feature is turned On, programs without ratings will be blocked.

## US

This option will block TV and Movie Ratings in the USA to prevent viewing of any content that you feel may be inappropriate (see below).

## Canada

This option will block TV and Movie Ratings in Canada to prevent viewing of any content that you feel may be inappropriate due to its content (see page 36).

## Motion Picture Ratings Table

NOT RATED	Contains no rating. Not Rated (NR) and Not Applicable (NA) programs. Movie has not been rated or ratings do not apply.
G	General audiences. All ages admitted.
PG	Parental guidance suggested. Some material may not be suitable for children.
PG-13	Parents strongly cautioned. Some material may be inappropriate for children under 13.
R	Restricted. Under 17 requires accompanying parent or adult guardian.
NC-17	No one 17 and under admitted.
X	Adults only

### NOTES

- If the movie does not carry a rating, the TV will not block it.
- Blocking NOT RATED programs may block emergency programming, sports, news, public service announcements, religious programs and weather.

## TV Parental Guide Ratings Table

TV-Y	All children. The themes and elements in this program are specifically designed for a very young audience, including children from ages 2-6.
TV-Y7	Directed to older children. Themes and elements in this program may include mild physical or comedic violence, or may frighten children under the age of 7.
TV-G	General audience. It contains little or no violence, no strong language, and little or no sexual dialogue or situations.
TV-PG	Parental guidance suggested. The program may contain infrequent coarse language, limited violence, some suggestive sexual dialogue and situations.
TV-14	Parents strongly cautioned. This program may contain sophisticated themes, intense sexual situation, more intense violence and intensely suggestive dialogue.
TV-MA	Mature audiences only. This program may contain mature themes, indecent language, graphic violence, and explicit sexual content.

FV: Fantasy/Cartoon Violence    V: Violence    S: Sexual Situation    L: Adult Language    D: Sexually Suggestive Dialogue

### NOTES

- If you Block TV-14D, you will still permit TV-MA programs; If you block TV-14V, you will automatically block TV-MAV programs, but you will still permit TV-MALS programs. This means that the TV will block violence in TV-14 and higher (TV-MA), but not language and sex.
- TV program ratings are dependent on the broadcaster. If the program is not rated, the TV will not block it.

# Setup

## Canadian Ratings English Table

C	Programming intended for children under age 8 - Violence Guidelines; Careful attention is paid to themes, which could threaten children's sense of security and well-being. There will be no realistic scenes of violence. Depictions of aggressive behavior will be infrequent and limited to portrayals that are clearly imaginary, comedic or unrealistic in nature. Other Content Guidelines: There will be no offensive language, nudity or sexual content.
C8+	Programming generally considered acceptable for children 8 years and over to watch on their own - Violence Guidelines: Violence will not be portrayed as the preferred, acceptable, or only way to resolve conflict; or encourage children to imitate dangerous acts which they may see on television. Any realistic depictions of violence will be infrequent, discreet, of low intensity and will show the consequences of the acts. Other Content Guidelines: There will be no profanity, nudity or sexual content.
G	General Audience - Violence Guidelines: Will contain very little violence, either physical or verbal or emotional. Will be sensitive to themes which could frighten a younger child, will not depict realistic scenes of violence which minimize or gloss over the effects of violent acts. Other Content Guidelines: There may be some inoffensive slang, no profanity and no nudity.
PG	Parental Guidance - Programming intended for a general audience but which may not be suitable for younger children. Parents may consider some content inappropriate for unsupervised viewing by children ages 8-13. Violence Guidelines: Depictions of conflict and/or aggression will be limited and moderate; may include physical, fantasy, or supernatural violence. Other Content Guidelines: May contain infrequent mild profanity, or mildly suggestive language. Could also contain brief scenes of nudity.
14+	Programming contains themes or content which may not be suitable for viewers under the age of 14 - Parents are strongly cautioned to exercise discretion in permitting viewing by pre-teens and early teens. Violence Guidelines: May contain intense scenes of violence. Could deal with mature themes and societal issues in a realistic fashion. Other Content Guidelines: May contain scenes of nudity and/or sexual activity. There could be frequent use of profanity.
18+	Adult - Violence Guidelines: May contain violence integral to the development of the plot, character or theme, intended for adult audiences. Other Content Guidelines: May contain graphic language and explicit portrayals of nudity and/or sex.

## Canadian Ratings French Table

G	General - Programming intended for audiences of all ages. Contains no violence, or the violence content is minimal or is depicted appropriately with humor or caricature or in an unrealistic manner.
8 ans+	8 + General - Not recommended for young children - Programming intended for a broad audience but contains light or occasional violence that could disturb young children. Viewing with an adult is therefore recommended for young children (under the age of 8) who cannot differentiate between real and imaginary portrayals.
13 ans+	Programming may not be suitable for children under the age of 13 - Contains either a few violent scenes or one or more sufficiently violent scenes to affect them. Viewing with an adult is therefore strongly recommended for children under 13.
16 ans+	Programming is not suitable for children under the age of 16 - Contains frequent scenes of violence or intense violence.
18 ans+	Programming restricted to adults - Contains constant violence or scenes of extreme violence.

## Region 5

Use Region 5 to block various types of movies and television programs based on ratings systems used in the U.S. that you feel may be inappropriate due to its content. The Region 5 option will operate for Digital Channels (ATSC) only.

## Ratings Procedure

1. Use the CURSOR PAD ◀ or ▶ to select the Rating Category (MPAA, TV Rating, etc.) that you want to block.
2. Press the SELECT button to block the RATING that you have selected.
3. Press the EXIT button to quit the menu.

## Region 5 Alternate Ratings (Example Only)

G	General audiences. All ages admitted.
PG	Parental guidance suggested. Some material may not be suitable for children.
PG-13	Parents strongly cautioned. Some material may be inappropriate for children under 13.
R	Restricted. Under 17 requires accompanying parent or adult guardian.
NC-17	No one 17 and under admitted.
X	Adults only.
Y	Adults only.

## NOTES

- In order to set the Region 5 Ratings the ATSC Digital channel received must include Region 5 Ratings data. To see if the channel has Region 5 Ratings, press the INFO button on the remote control.
- Once the TV has received Region 5 Ratings data, the Region 5 option in the Parental Controls menu will become available and display the data.

# Setup

## Closed Captions

Closed Captions are the dialogue, narration, and/or sound effects of a television program or home video which are displayed on the TV screen. Your local TV program guide denotes these programs as **CC** or .

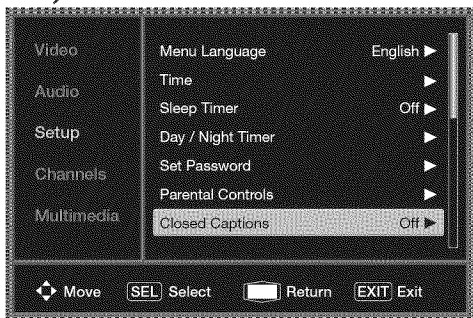

1. Use the CURSOR PAD **▶**, **▲** and **▼** to highlight and select the function to change.
2. Press the EXIT button to quit menu or press menu to return to the Main menu items.

### Closed Captions:

**On/Off** will turn the display **CC** on or off.

**With Mute** will turn the display **CC** on when Mute is on.

### Digital Captions

Set captions for digital programs and set available language.

### Digital Captions Options

This function will help choose and set font, size, color and background style of digital captions.

#### NOTES

- The Digital Closed Captions feature only works when using the "TV" input of this television.
- Caption Display will not work when viewing a 480i, 480p, 720p, 1080i or 1080p input via the COMPONENT: Y-PbPr or HDMI inputs.
- Analog and digital Closed Captions availability and content depends on the broadcaster. Digital Closed Caption are available when the Closed Caption icon is displayed on the info banner.
- Digital Captions language will not be available (grayed out) when using analog channels.

### Analog Captions:

Set captions for analog programs. This function will help choose and set available mode and channel.

**CC1, CC2, etc.** : These are for the program you are viewing.

**TEXT1, etc.** : These are for additional information such as news reports or a TV program guide. This information covers the entire screen and viewing the TV program is not possible. Text may not be available with every **CC** program.

## Energy Options

Use this feature to save energy when watching your Hitachi LCD TV.

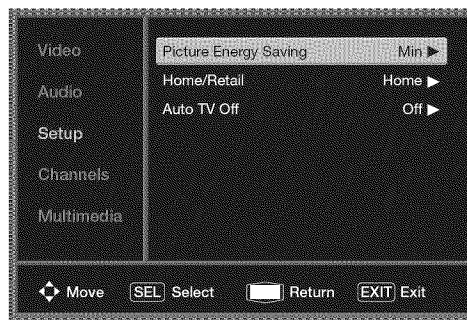
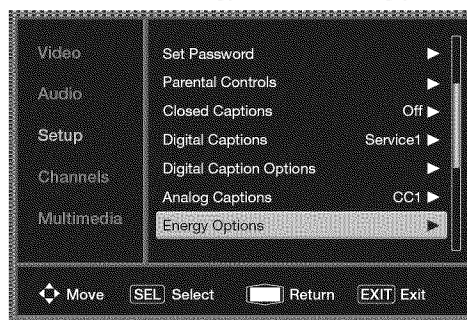

1. Press the CURSOR PAD **▲** or **▼** to highlight Energy Options.
2. Press the CURSOR PAD **▶** to select your choice.

### Picture Energy Saving

This function allows you to choose power consumption reduction based on 3 levels (Min, Medium, and Max).

### Home/Retail

This function allows you to return to the Energy Savings Initial Setting screen (see page 13).

#### NOTE

The Retail mode is intended for showroom or shop-use only, if you make any video or audio adjustment changes in this mode, they will not be saved when the TV is turned AC Off.

### Auto TV Off

This function turns off the TV when no remote control signal is detected for 3 hours to save energy. Please choose On or Off to set this feature.

### Light Control

This feature allows you to turn Off/On the LED indicating light in front of your LCD TV.

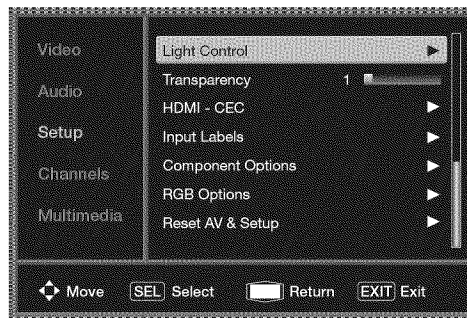

1. Press the CURSOR PAD **▲** or **▼** to highlight Light Control.
2. Press the CURSOR PAD **▶** or SELECT button to enter the Light Control menu.

# Setup

## Power LED

Select this feature to turn Off or On the Power LED indicator on the front panel on your TV.

## Transparency

This function allows you to change the transparency of OSD based on 10 levels (0 opaque ~ 10 transparent). Adjust to your own preference.

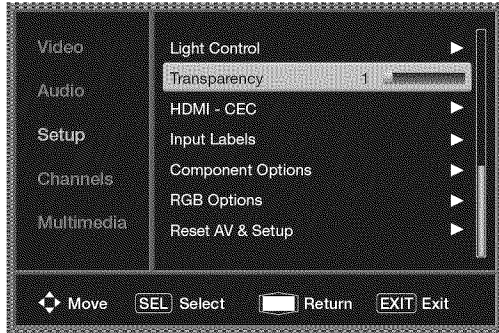

1. Press the CURSOR PAD ▲ or ▼ to highlight Transparency.
2. Press the CURSOR PAD ► or SELECT button.
3. Press the CURSOR PAD ► to increase or CURSOR PAD ◀ to decrease the OSD transparency.

## HDMI-CEC

Set to On and this feature will enable the HDMI-CEC signal bus to allow your Hitachi LCD TV to discover and communicate automatically with other compatible HDMI-interfaced Audio/Video device. The CEC signal bus makes global controls possible, based on "plug & play" automation, to minimize the number of IR remotes and key-presses required for basic operation of your AV device. Select Off to disable this option.

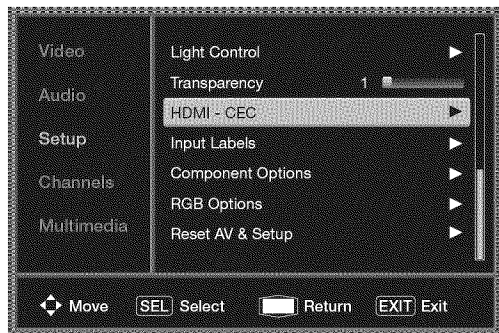

With the "HDMI-CEC" feature, you can interface the connected device through the HDMI jack automatically if the connected device meets the "HDMI CEC (Consumer Electronics Control)" industry standard. Please check if the connected device supports HDMI CEC before using this feature. For example, here are three common functions after setting item "CEC Enable" to "On".

Feature	Description
<b>One-Touch Play (TV Auto On)</b>	Pushing the "Play" button on the CEC enabled device will command the device to play, turn the TV on, and the HDMI input, that the device is connected to, will become the active input device for the TV.
<b>System Standby (Device Auto Off)</b>	When the user turns off the TV, all active CEC enabled devices on the HDMI input will go to Standby.
<b>Playback Control</b>	The user can operate the CEC enabled device's deck control functions (i.e. Play, Stop, Fast Forward and Rewind) by the TV's remote control's transport keys (i.e. ►, ■, ◀ and ►►).

### NOTE

Not all devices with an HDMI connection have the CEC feature. Consult the instruction manuals for the device you are trying to control to confirm whether or not CEC is available.

## Input Labels

Use this feature to give a name to any of the nine video inputs excluding the TV input.

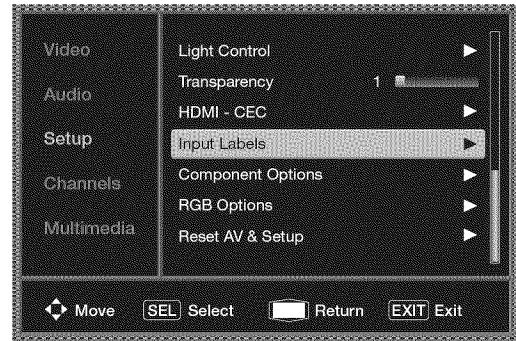

1. Press the CURSOR PAD ▲ or ▼ to highlight Inputs Labels.
2. Press the CURSOR PAD ► to select your choices.

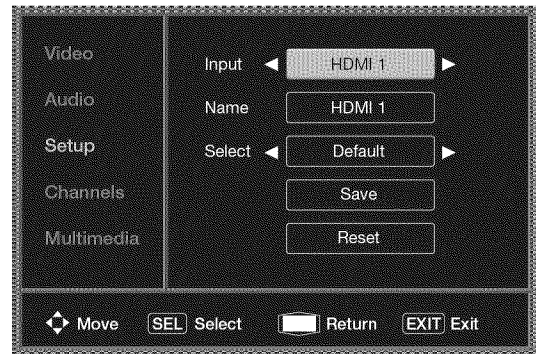

### NOTE

Input Labels is Grayed out (Skip) or disabled until you are on the INPUT that you like to change. When the Custom option is selected a Keyboard will appear on the screen to place your desired label.

# Setup

## Component Options

This function allows you to adjust the phase between your TV and the Device with component output.



1. Press the CURSOR PAD ▲ or ▼ to highlight Component Options.
2. Press the CURSOR PAD ► to select your choice.

There are two options for the Component inputs:

### Phase

Use this feature to fine-tune the display to perfectly synchronize with the video signal source.

**Reset:** Return to the original condition for Component inputs.

## RGB Options

This function is to adjust the RGB input to match your PC or laptop output with your LCD Television.



1. Press the CURSOR PAD ▲ or ▼ to highlight RGB Options.
2. Press the CURSOR PAD ► to select your choices.

There are six options for the RGB input. H-Position, V-Position, Clock, Phase, Auto Adjust and Reset.

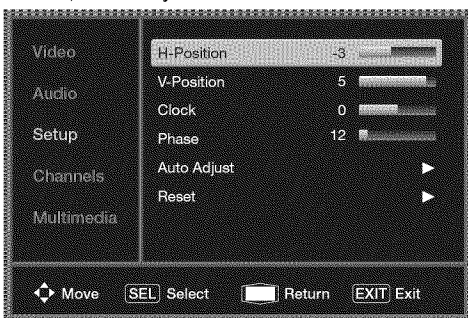

### H-Position

Adjusts the display position horizontally.

### V-Position

Adjusts the display position vertically.

### Clock

Minimizes vertical stripes on the screen.

### Phase

Minimizes the blurring of letters and stripes on horizontal row.

## Auto Adjust

Adjusts Horizontal Position, Vertical Position, Clock, and Phase automatically.

## Reset

Each item in RGB Options Menu will be restored to the factory setting by selecting Yes.

## Reset AV & Setup

This feature restores all Audio, Video and Setup configuration that you have made on the TV and it will return to the factory settings.

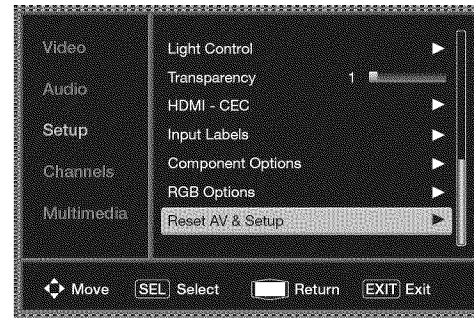

# Channels

Select Channels to set your signal source options, run New Channel Scan, Check Signal Meter and Set Channel List (Add channels to List, Channel/Labels and Favorite Channels).



1. Press the CURSOR PAD ▲ or ▼ to highlight functions.
2. Press the SELECT button or the CURSOR PAD ► enter the next popped-up menu.
3. Press the CURSOR PAD ▲ or ▼ to select.

## Source

Select the signal Source for the TV. When using an indoor or outdoor antenna select Air. When using a cable system select Cable.

## Signal Strength

Select Signal Strength when using an indoor or outdoor antenna. This feature will show the signal strength of the antenna signal to help you adjust your antenna to optimize signal reception. Use the MENU button or EXIT button to return.

**NOTE** The Signal Strength meter will not be available (grayed out) when watching analog channels.

## New Channel Scan

This feature will automatically store active Analog and Digital channels to the Channel list. This scan will erase all channels previously stored in the list.



1. Use the CURSOR PAD ▲ or ▼ to highlight then press SELECT button to start.

**NOTE** If you do not want to erase all scanned channels, please use the Add Channels to List option instead.

## Add Channels to List

This function allows you to add channels to the channel memory. Sometimes adjusting the antenna direction will allow reception of additional channels.

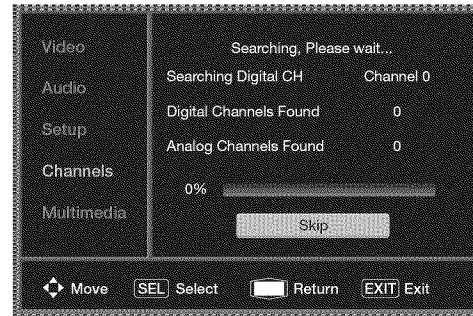

1. Use the CURSOR PAD to select the Add Channels to List.
2. Press the SELECT button to start scanning.
3. Press the EXIT button to return to normal viewing.

**NOTE** Only the Channels that have been added to the list will be stored.

## Channel List

This function allows you to review which channels have been added to the Channel List.



1. Use the CURSOR PAD to navigate the Channel List.
2. Press the SELECT button or the CURSOR PAD ► to select Skip or View.
3. Press the EXIT button to return to normal viewing.

**NOTE** The Channel List cannot be updated by only changing the signal. Auto Channel Scan must be performed for the Channel List to be updated.



# Channels/Multimedia

## Channel Labels

Use this feature to give a name to any of the channels.

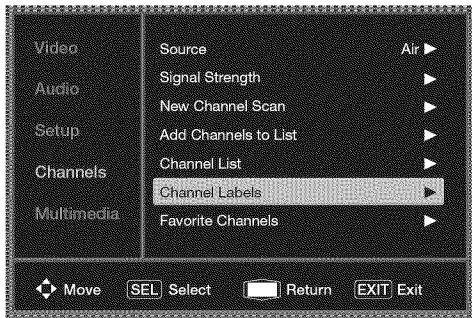

1. Press the CURSOR PAD ◀ or ▶ to highlight the channels.
2. Press the CURSOR PAD ▼ to change the channel label.
3. Press the SELECT button to show the keyboard for editing the channels.

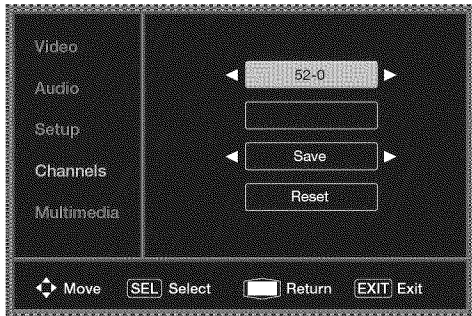

## Favorite Channels

This function allows you to manage your Favorite Channels.

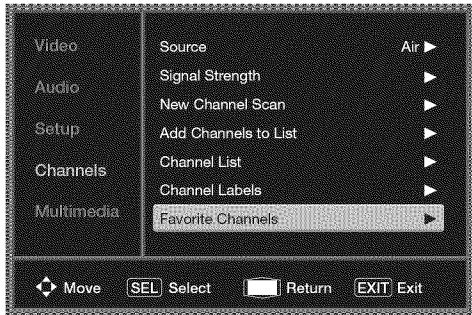

1. Use the CURSOR PAD to navigate the Favorite Channels.



2. Press the SELECT button or CURSOR PAD ▶ to check mark the channel and make it a Favorite channel. Select all desired channels.

3. Press the EXIT button to return to normal viewing.
4. To view all the Favorite channels that you have chosen, press the FAV CH button on the remote control.

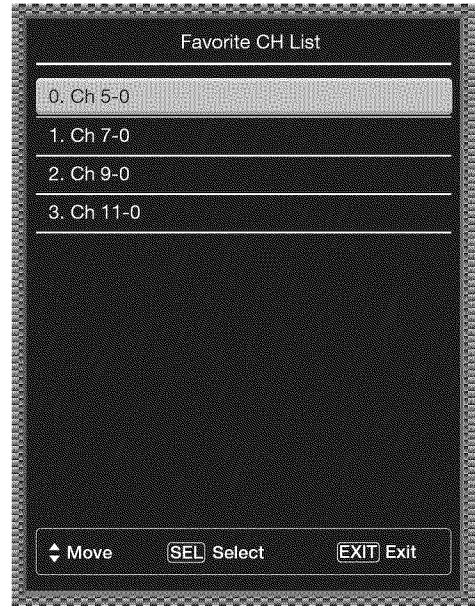

## Multimedia

This feature is useful for viewing digital still pictures from USB Drives using the USB slot in the side panel of your Hitachi LCD television.

Upon inserting a USB drive into the USB slot, you will be prompted to view these photos with the JPEG viewer feature or you can access them via the OSD Main Menu under Multimedia. Using the remote control's CURSOR PAD you can navigate through thumbnails and individually select pictures you would like to view. During manual playback of selected photos, the CURSOR PAD can be utilized to scroll through your pictures. Additionally, using the Menu button on the remote control in the Browser View or Picture View mode you can activate and set Slideshow options.

### NOTE

*This option will remain grayed out until a USB drive containing pictures (JPEG format) is inserted and recognized by TV.*

# Equipment Care and Troubleshooting

## DO

Dust the screen and cabinet with a soft cloth.

Clean the screen with a soft cloth moistened in warm water and dry with a soft cloth. A mild soap may be used if the screen is extremely dirty.

Place your LCD Television away from extreme heat, humidity and extremely dusty places.

Remove the plug from the AC outlet if your LCD Television will not be used for a long period of time, for instance, when you go on vacation.

## DO NOT

Do not clean your screen with strong cleaners, polishes or a chemically treated cloth.

Do not place rubber or vinyl products or tape on your LCD Television.

Avoid repeatedly touching the screen.

Do not drop or hit the remote control. This may cause damage its internal parts.

Avoid placing the remote control in a high humidity place or getting it wet. Do not leave it on or near a heater. Excessive heat or moisture may cause the unit to fail.

When the batteries run down, remote control operation will become erratic or become unresponsive. Replace the old batteries with two new "AAA" size batteries. Do not use an old battery with a new battery.

Exposing the screen to direct sunlight for a long period of time or heat may cause damage to the LCD screen.

Troubles are sometimes caused by simple "faults" that you can correct without the help of a service technician. If you experience any difficulty with your TV, check a few basic remedies before calling your service technician.

### TV will not turn ON

1. Press the POWER button (ON/OFF button) once.
2. If there is still no power, wait 30 seconds and press the POWER button again.
3. If there is still no power, unplug the power cord from the wall. Wait 30 seconds and plug the power cord back in. Press the POWER button again.

### When the Following Messages Appear on the Screen

Message	Condition / Action
No Signal	<p>The unit cannot detect any signals from any input jacks or the TV channel does not show picture.</p> <ul style="list-style-type: none"><li>• Check if the cable is connected correctly and firmly.</li><li>• Check if the power of any external device is ON.</li><li>• Check if the input selection matches the connection jack.</li><li>• This message will be displayed for 15 minutes then the TV will turn Off.</li></ul>

# Troubleshooting

## Symptom and Checklist

SYMPTOM	CHECKLIST	PAGES
No picture - no sound	<ul style="list-style-type: none"> <li>• Check the Indicating lamp status (Off, Red, Blue).</li> <li>• Check the connection of the power cord and/or other cables.</li> <li>• Check if the power of the unit or external device is ON.</li> <li>• Check if the correct Video input is selected.</li> <li>• Check if the unit is in "Standby mode" .</li> <li>• Adjust the values in "Video menu" and "Audio menu".</li> </ul>	9, 12, 14~17 30~33
Multiple images-normal sound	<ul style="list-style-type: none"> <li>• Check the connections to external device.</li> </ul>	14~17
Intermittent interference	<ul style="list-style-type: none"> <li>• Check if the source of interference is shielded correctly.</li> <li>• Move these kinds of electrical devices away from the unit.</li> </ul>	44
Normal picture, but no sound	<ul style="list-style-type: none"> <li>• Check the volume level.</li> <li>• Check if the MUTE button has been pressed or not.</li> <li>• Check the connections to external device.</li> <li>• Try next/other Audio Language.</li> </ul>	14~18 33
No picture - normal sound	<ul style="list-style-type: none"> <li>• Check the value level of "Brightness" and "Contrast" in "Video Menu".</li> </ul>	31
The remote control does not work.	<ul style="list-style-type: none"> <li>• Check if the batteries are installed correctly.</li> <li>• The batteries might be exhausted. Replace them with new ones.</li> <li>• Remove all obstructions from in front of the sensor window on the unit.</li> <li>• Check if the buttons on the control panel are working.</li> </ul>	6, 9
The buttons on both the remote control and control panel do not work.	<ul style="list-style-type: none"> <li>• Unplug and connect the power cord again.</li> </ul>	7, 42
Normal picture but no color-normal sound	<ul style="list-style-type: none"> <li>• Check the connections to external device.</li> </ul>	14~17
No picture The Indicating lamp → Off	<ul style="list-style-type: none"> <li>• Check if the power cord is plugged into the socket securely.</li> </ul>	7, 9
No picture The indicating lamp → Blue	<ul style="list-style-type: none"> <li>• Check if the signal cable is connected correctly and securely.</li> <li>• Adjust the level of Brightness and Contrast lower.</li> </ul>	12, 14~17, 31
Some screen display aspects cannot be switched in.	<ul style="list-style-type: none"> <li>• Check the signal status by pressing the INFO button on the remote control. The available screen display aspect is different depending on the current signal status.</li> </ul>	11, 20 55
No power	<ul style="list-style-type: none"> <li>• Check the power cord is connected to the AC outlet.</li> </ul>	9, 12
Turns Off by itself	<ul style="list-style-type: none"> <li>• Check or ensure Sleep Timer settings are not activated.</li> </ul>	11, 18, 34
Turns On by itself	<ul style="list-style-type: none"> <li>• Check if the HDMI-CEC feature is activated.</li> </ul>	38
Picture may "block" or freeze when watching a digital channel.	<ul style="list-style-type: none"> <li>• Check signal strength under "Signal Strength".</li> </ul>	40

## HDMI Issues

SYMPTOM	CHECKLIST	PAGES
No picture - no sound	<ul style="list-style-type: none"> <li>• Make sure you have selected the correct HDMI input. Toggle through them while HDMI device is ON or during playback.</li> <li>• Unplug and re-plug HDMI connection while TV and HDMI device are powered on.</li> <li>• Turn TV and HDMI device off. Turn TV on first and then HDMI device second.</li> </ul>	14, 15, 17, 19
Error notice comes to screen	<ul style="list-style-type: none"> <li>• Try pressing "exit" on HDMI device remote control and then on TV remote to find source of the error OSD. If error persist or comes back even after pressing exit, try alternate HDMI input on TV.</li> <li>• Unplug and re-plug HDMI connection while TV and HDMI device are powered on.</li> <li>• Turn TV and HDMI device off. Turn TV on first and then HDMI device second.</li> </ul>	9, 11 14, 17
Normal picture, but no sound	<ul style="list-style-type: none"> <li>• Check HDMI Audio settings under the HDMI device menu (of the HDMI source device). In order to get sound on TV, HDMI output must be set to PCM option.</li> </ul>	
No sound from TV Optical Out when using HDMI devices	<ul style="list-style-type: none"> <li>• Change Digital Output selection.</li> <li>• As an option, use audio optical output from HDMI source device directly to separate Audio Amplifier.</li> </ul>	33
Picture flickers during channel change w/ using HDMI set top boxes	<ul style="list-style-type: none"> <li>• This is normal operation from the source switching delay itself. It's not an indicator of a TV malfunction.</li> </ul>	
Picture is blurry or fuzzy	<ul style="list-style-type: none"> <li>• If HDMI source is HD capable, ensure it's output is set to 1080p, 1080i or 720p under HDMI device menu (of the HDMI source device).</li> </ul>	
Pixelization noise or loss connection ("No Signal" message display)	<ul style="list-style-type: none"> <li>• Check HDMI input picture format, if use 1080p format confirm cable length it is recommended that the length of the cable should be less than 5 meters, or change HDMI input picture format to 1080i.</li> </ul>	

If the problem cannot be solved with the suggested procedures, contact 800.HITACHI. For your safety, never try to repair the product yourself.

# Reception Problems

---



## **IGNITION NOISE:**

Black spots or horizontal streaks may appear, picture may flutter or drift. Usually caused by interference from automobile ignition systems, neon lamps, electrical drills, and other electrical appliances.

---



## **GHOSTS:**

Ghosts are caused by the television signal following two paths. One is the direct path and the other is reflected from tall buildings, hills or some other objects. Changing the direction or position of the antenna may improve reception. Ghosting may also be caused by defects in the antenna system such as unshielded leads or connecting several sets to the same antenna without using multiple antenna couplers.

---



## **SNOW:**

If your receiver is located in the fringe area of a television station where the signal is weak, your picture may be marred by the appearance of small dots. When the signal is extremely weak, it may be necessary to install a special antenna to improve the picture.

---

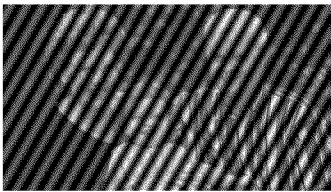

## **RADIO FREQUENCY INTERFERENCE:**

The interference produces moving ripples or diagonal streaks, and in some cases, causes loss of contrast in the picture.

## **PREVENTION OF AN OBSTACLE TO RADIO RECEIVERS**

This television has been designed pursuant to the FCC class B Rules. This is to prevent a problem to Radio receivers. If this television causes a problem to Radio receivers, then take the following steps:

- Keep the television away from Radio.
- Adjust Radio antennas in order for the television not to receive interference.
- The antenna cable of Radio should be kept away from the television.
- Use a coaxial cable for antenna.

You can check if this television influences Radio receivers by turning off all other device other than the television. If you find a problem receiving Radio when using the television, check the instructions mentioned above.

---



## **BLOCK NOISE or FREEZE (DIGITAL INPUT):**

Fuzzy blocks may appear in some area or the whole area of the screen. This is usually caused by interference from automobile ignition systems, neon lamps, electrical drills, ghosting of the image and lost or weak receiving signals.

---

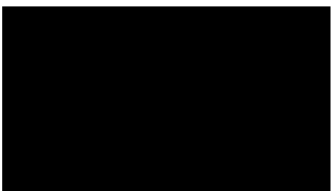

## **BLACK SCREEN:**

When using an antenna, weak signals will display a black screen. It may be necessary to upgrade your antenna.

---

### **NOTE**

*The TV set can generate sound distortion in external devices such as a radio. Please separate radio device from the TV set to a considerable distance.*

# Features and Specifications

## Features:

- **New** High Gloss Black Frame
- (4) HDMI® (V.1.3 with Deep Color, CEC)
- 1080p60, 1080p24 Input Compatible
- **New** Multi-Function Remote Control
- 120Hz 1080p Perfected
- Reel 120 Motion Correction
- Dynamic/Standard/Movie/Custom/Game/Pro-Day/Pro-Night Picture Memories
- 3 Preset Color Temperatures
- Game Mode
- Calibration Menu

## Video:

- 1920 x 1080p Display Resolution
- Wide Viewing Angle
- Color Temperature Presets: High, Medium, and Standard
- Multiple Screen Fill Modes: (Auto/4:3/16:9/Zoom1/Zoom2/Full)<sup>1</sup>
- 4MB 10-bit 3D Y/C Comb Filter
- Picture Modes: Dynamic/Standard/Movie/Custom/Game/Pro-Day/Pro-Night

## Audio:

- CONEQ™ Sound Quality
- MTS Stereo/SAP
- 4 Sound Modes (Custom, Standard, Movie, News)
- Rated Output Power: 12W+12W

## Inputs:

- Power Input . . . . . AC 120V, 60Hz
- Power Consumption
  - Maximum Power L46S604 . . . . . 210 W, 1.76A
  - Maximum Power L55S604 . . . . . 240 W, 2.10A
- Antenna Input Impedance . . . . . 75 Ohm
- Channel Coverage . . . . . 191ch.
  - VHF-Band . . . . . 2~13
  - UHF-Band . . . . . 14~69
  - CATV Mid Band . . . . . A5~A1, A~I
  - Super Band . . . . . J~W
  - Hyper Band . . . . . W+1~W+28
  - Ultra Band . . . . . W+29~W+94
- Television System . . . . . NTSC Standard
  - . . . . . ATSC Standard (8 VSB, 64-QAM, 256-QAM)
- Video . . . . . 1.0Vp-p, 75 Ohm
- S-Video
  - Luminance(Y) . . . . . 1.0Vp-p, 75 Ohm
  - Chrominance(C) . . . . . 0.286Vp-p, 75 Ohm
- Component Video
  - Luminance(Y) . . . . . 1.0Vp-p, 75 Ohm
  - Chrominance(Pb/Pr) . . . . . 0.7Vp-p, 75 Ohm
- Audio Input Impedance . . . . . >10k Ohm
- Audio Input Sensitivity . . . . . 500mVrms
- HDMI . . . . . (19 PIN)

## Supplied Accessories:

- Remote Control
- Batteries (AAA)
- Power Cord
- Owners Guide
- Easy Graphic Guide
- Stand Base
- Stand Screws

## Inputs/Outputs:

- Wideband Component Y, Pb, Pr . . . . . 2
- Composite Video . . . . . 2
- S-Video . . . . . 2
- Antenna (RF) Input . . . . . 1
- Audio Output . . . . . 1
- Optical Output . . . . . 1
- HDMI . . . . . 4
- USB Multimedia/Upgrade Slot . . . . . 1
- RGB Input . . . . . 1
- RGB Audio Input . . . . . 1
- Phono Jack for Headphone . . . . . 1
- DVI Audio Input . . . . . 1

## Specifications:

- FCC class . . . . . B for Consumer Use
- Power Requirements . . . . . 108-132VAC, 60Hz

<sup>1</sup> Screen mode availability varies by input format.

VGA and XGA are trademarks of International Business Machines Corporation.

VESA is a registered trademark of the Video Electronics Standard Association.

HDTV Televisions display HDTV only when an HDTV source is available.

All specifications, weights, and dimensions are subject to change without prior notice. Please access [www.hitachi.us/tv](http://www.hitachi.us/tv) for detailed specifications and dimensions for custom installations.



InstaPort and the InstaPort logo are trademarks or registered trademarks of Silicon Image, Inc. in the United States and other countries.



HDMI, the HDMI logo and High-Definition Multimedia Interface are trademarks or registered trademarks of HDMI Licensing LLC in the United States and other countries.



Manufactured under license from Dolby Laboratories. Dolby and the double-D symbol are trademarks of Dolby Laboratories.



Manufactured under license from Real Sound Lab, SIA. CONEQ is a trademark of Real Sound Lab, SIA. CONEQ™ delivers clear, rich sound using proprietary professional equalizing technology. Dialog is clear and music sounds more dynamic when the speakers are perfectly optimized.



CONEQ HA Mode™ (Hearing Aid) technology produces natural sound for the hearing impaired. The listener can enjoy details in music and clear dialog often without the help of a hearing aid.



CONEQ™ 3D Sound produces a natural three-dimensional sound experience. CONEQ 3D Sound compliments any program by providing musically accurate sound.

# Set Dimensions

L46S604 model (Includes Table Top Stand) Weight (lbs./kg): 53.3/24.2

Units : Inches (mm)

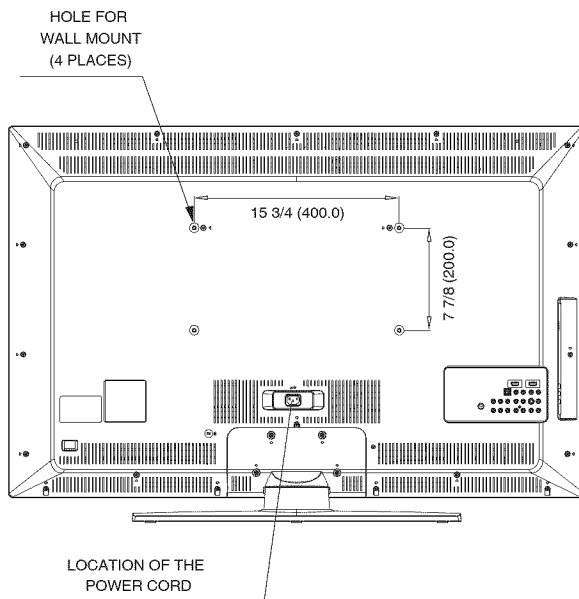
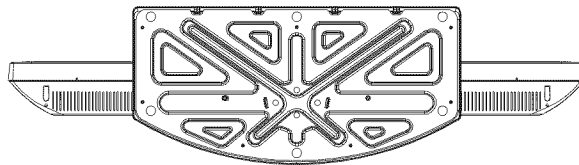
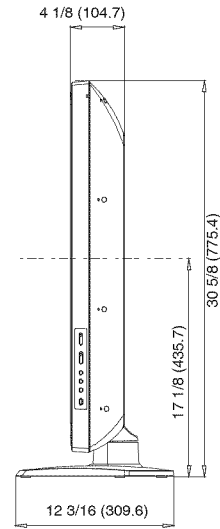
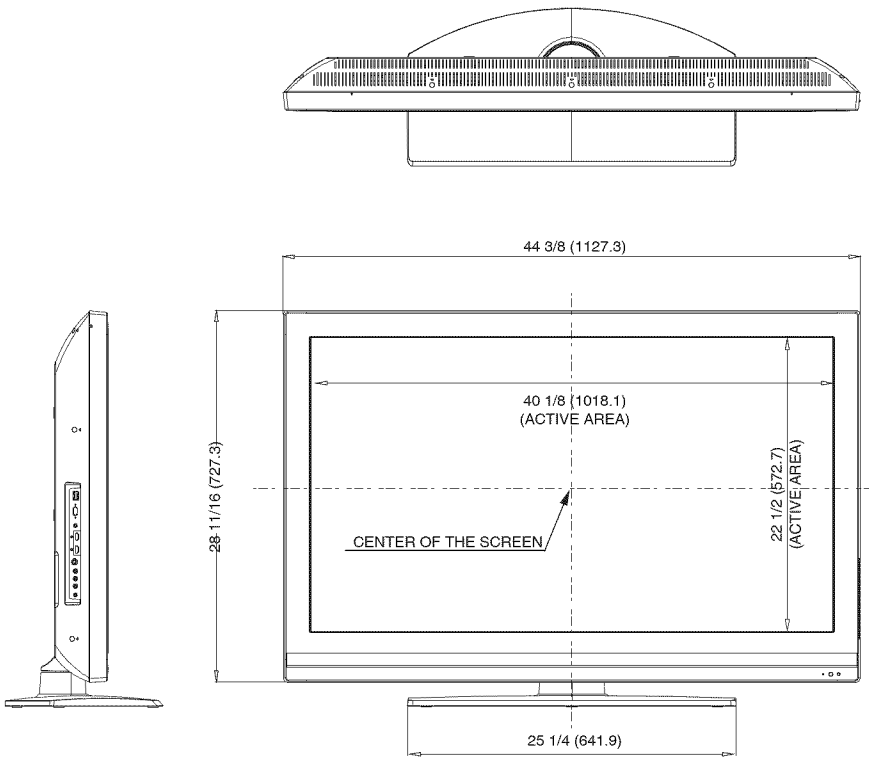

Rear View  
Use as Reference for Wall Mount Bracket

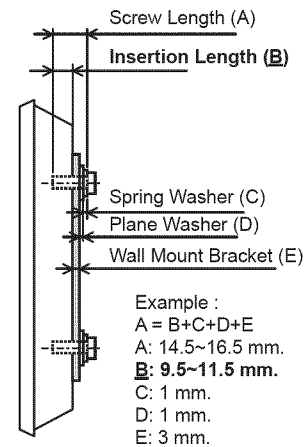

• The screw type : Thread ISO M6 (Metric type, do not use Standard type).

Side View  
Wall Mount Screw specification

# Set Dimensions

L55S604 model (Includes Table Top Stand) Weight (lbs./kg): 81.1/36.8

Units: Inches (mm)

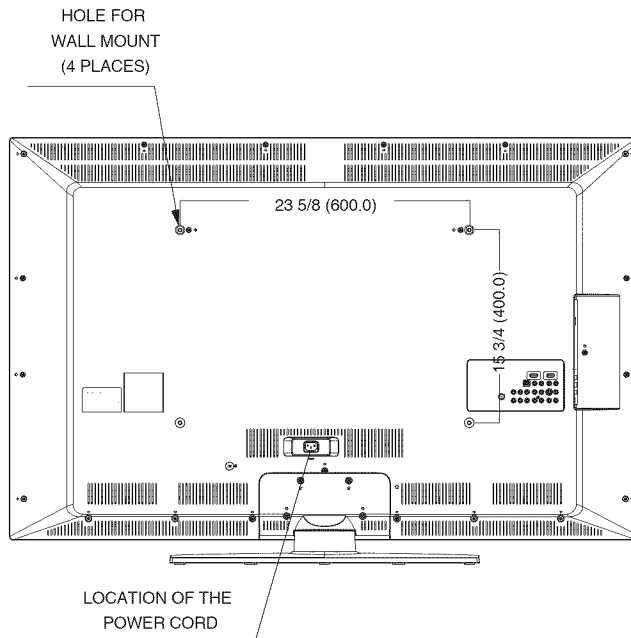
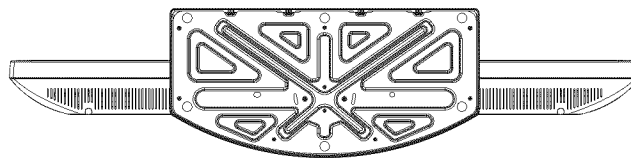
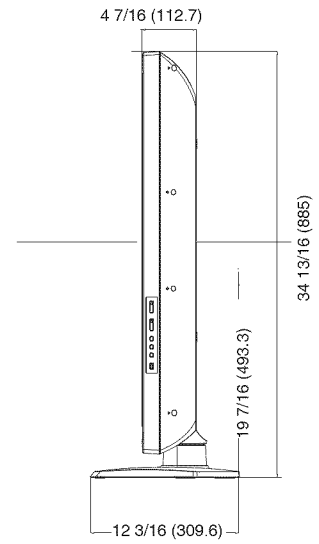
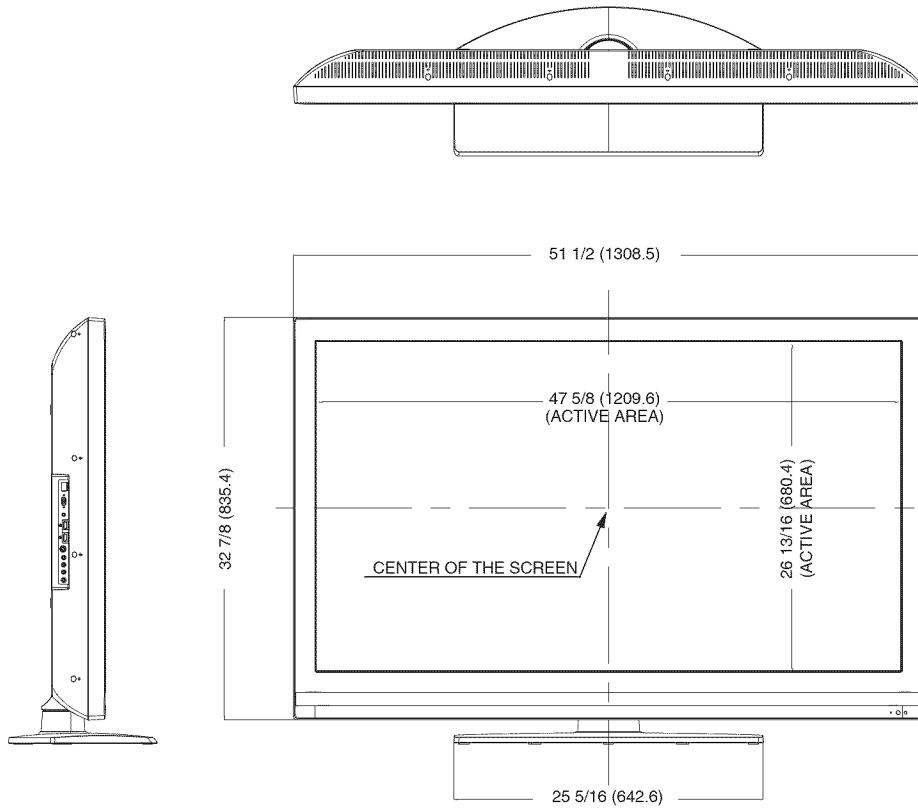

Rear View  
Use as Reference for Wall Mount Bracket

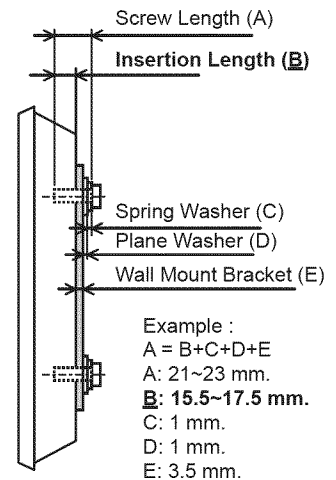

•The screw type : Thread ISO M6 (Metric type, do not use Standard type).

Side View  
Wall Mount Screw specification

USEFUL INFORMATION

# Service Information

**800.HITACHI**  
(800.448.2244)

**Monday ~ Friday**  
**8:00 am - 7:00 pm CST**

[www.hitachi.us/tv](http://www.hitachi.us/tv)



**Sincere - Prompt - Efficient**

**HITACHI**  
Inspire the Next

HITACHI AMERICA, LTD.

HITACHI has made every effort to assure you hours of trouble free operation from your Hitachi product. Should you require service assistance with **OPERATIONAL, HOOK UP, TECHNICAL ASSISTANCE OR WARRANTY SERVICE SUPPORT**, please contact one of our knowledgeable Customer Service Representatives at **800.HITACHI (800.448.2244)**.

Our Customer Service Representatives will provide you with the assistance you need and if necessary coordinate the repair process with a local Authorized Service Facility in your area. Please be prepared to submit proof of purchase and/or delivery receipts to your 800.HITACHI Customer Service Representative. Warranty coverage will be provided in accordance with the provisions of your Limited Warranty (see the Limited Warranty page in this owners guide).

Pour de plus amples renseignements sur le service durant la période couverte par la garantie, sur le fonctionnement ou pour de l'assistance technique communiquez avec:

**Au Canada: 800.HITACHI (800.448.2244)**

Lundi~ Vendredi 8:00 am – 7:00 pm HNC

**Hitachi America, Ltd., Digital Media Division**  
**Customer Service Support**  
PO Box 3900  
Peoria, IL 61612  
U.S.A.: [customerservice.ce@hal.hitachi.com](mailto:customerservice.ce@hal.hitachi.com)  
Canada: [customerservice.canada@hal.hitachi.com](mailto:customerservice.canada@hal.hitachi.com)

## Customer Record

The MODEL NAME and SERIAL NUMBER of this product is located on the backcover and also on the RIGHT SIDE of the set. Please follow the next steps to find this information and then record it in the space provided below for use in case you call 800.HITACHI, they will require this information in order to give you the proper support.

- 1 Look on the right side of the set.
- 2 Locate the label where it shows the information related to MODEL NAME and SERIAL #.
- 3 800.HITACHI will require this information in order to give you the proper support regarding your questions.

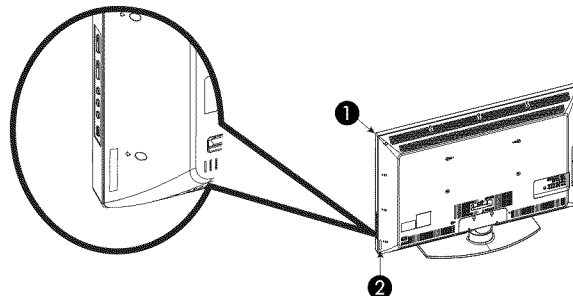

Model Name \_\_\_\_\_

Serial Number \_\_\_\_\_



# Limited Warranty

Congratulations on your purchase of a new Hitachi display product.

## LIMITED WARRANTY

Hitachi America, Ltd. warrants this product in accordance with the terms and conditions applicable to the products identified below:

## Conditions of Hitachi Limited Warranty

This Hitachi display product (the "Product") is warranted to be free from defects in materials and workmanship beginning on the date of purchase by the original owner and continuing for the duration of the applicable time periods specified below. If the Product is found to be defective, Hitachi will repair or replace (at Hitachi's option) defective parts at no charge, subject to the conditions of this Limited Warranty. If the original owner rejects, refuses or otherwise does not accept Hitachi's offer to repair or replace such defective parts under this Limited Warranty, this Limited Warranty shall be void and of no further force or effect. This Limited Warranty extends to the original owner only and is not transferable, and such owner must provide a dated sales receipt for the Product to qualify for parts or service under this Limited Warranty. The original owner must notify Hitachi of a defect claim by calling 800.HITACHI during the applicable Limited Warranty period for this Limited Warranty to be effective. This Limited Warranty is valid only in the U.S.A. and Puerto Rico.

Hitachi Product :  
LCD Flat Panel Televisions

**PARTS:** The Limited Warranty period for parts is 1 year from the date of original purchase. During the Limited Warranty period for parts, Hitachi will replace defective parts with new or rebuilt parts (at Hitachi's option) at no charge for such parts. Any replacement part will be warranted for the remainder of the original warranty period applicable to the part replaced.

**LABOR:** The Limited Warranty period for labor is 1 year from the date of original purchase. During the Limited Warranty period for labor, Hitachi will repair or replace (at Hitachi's option) defective parts without charge for labor.

**SERVICE LOCATION:** In-home warranty service, which includes either in-home repair or free pick-up and delivery (at Hitachi's option), applies to all Hitachi products except: (i) 32-inch and smaller LCD Flat Panel Televisions; (ii) Products located outside the U.S.A. or Puerto Rico; (iii) Products located more than seventy-five (75) driving miles from Hitachi's nearest Authorized Service Facility. If the foregoing clauses (i), (ii), (iii) apply, then the Product owner will be responsible for bringing/delivering the Product to a Hitachi Authorized Service Facility and, following warranty service, retrieving the Product from such Authorized Service Facility.



CERTIFIED  
SERVICE  
CENTER

Hitachi is a proud supporter of the Certified Service Center program. Businesses who display the CSC certification mark have demonstrated that they operate in accordance with the high standards of professionalism prescribed by the Consortium for Certified Service Centers.

### IMPORTANT:

Before using or installing your Product, please complete this form and attach your sales receipt and retain them for your records. This will help facilitate proper warranty coverage.

### Warranty Limitations

This Hitachi Limited Warranty does not cover:

- A. Any Product that has been modified or repaired in a manner not previously authorized by Hitachi in writing.
- B. Any Product whose serial number has been removed, altered, replaced, defaced or rendered illegible.
- C. Any defect, malfunction, or failure caused by or resulting from improper or unauthorized service, maintenance or repair.
- D. Damage resulting from abuse, misuse, mishandling, neglect or damage caused by exposure to hostile operating environments such as areas containing dust and/or smoke.
- E. Damage caused by power surges, accidents, natural disasters or any other events or circumstances outside Hitachi's control.
- F. Any Product used in any manner inconsistent with the acceptable set-up, usage, safety or installation configurations identified in the Product's Owners Guide.
- G. Any Product used for purposes or applications, or subjected to operating conditions, other than those identified as acceptable in the Product's Owners Guide.
- H. Product repairs (including any product whose case has been opened), or part replacements provided or installed, by any person other than an Authorized Hitachi Service Facility Representative.
- I. Improper uncrating, set-up or installation or any misadjustments caused by user-operated controls.
- J. Any labor or costs associated with removing the Product from a custom cabinet or other specialized product installation that impedes direct and immediate removal of the Product from the owner's premises (must be arranged and paid by the owner).
- K. Product cabinets, cabinet parts, knobs, batteries or accessories.
- L. Product screens that have been cleaned by any method other than as specified in the Product's Owners Guide.
- M. Normal usage, degraded brightness caused by backlight aging and/or cell defects or ordinary wear and tear, including, without limitation, scratches or marks on the Product's screen, cabinet or the appearance of bright or dark screen pixels.
- N. Any Product returned for service that is damaged due to improper packaging, mishandling or shipping. (IMPORTANT: When shipping any Product to a Hitachi Authorized Service Facility, Product owner must package it securely in the original shipping container or its equivalent to prevent damage. The Product must be returned with the shipping charges prepaid and proof of purchases included in the shipping container. Failure to properly package such product during such shipment will void all warranties.)
- O. Any Product purchased or serviced outside the United States of America and Puerto Rico.
- P. Any Product that has been used for commercial purposes.

NO PERSON, AGENT, DISTRIBUTOR, DEALER, SERVICE FACILITY, OR COMPANY IS AUTHORIZED TO CHANGE, MODIFY OR AMEND THE TERMS OF THIS LIMITED WARRANTY IN ANY MANNER WHATSOEVER. EXCEPT AS PROVIDED IN THIS LIMITED WARRANTY, HITACHI MAKES NO EXPRESS WARRANTY REGARDING THIS HITACHI PRODUCT. FURTHER, ALL IMPLIED WARRANTIES RELATING TO ANY PORTION OF THIS PRODUCT, INCLUDING ANY WARRANTY OF MERCHANTABILITY OR FITNESS FOR A PARTICULAR PURPOSE, ARE LIMITED TO THE DURATION SPECIFIED UNDER THIS LIMITED WARRANTY. HITACHI SHALL NOT BE LIABLE TO THE PURCHASER OR TO ANY OTHER PERSON FOR ANY INCIDENTAL OR CONSEQUENTIAL DAMAGES OR LOSS OF PROFIT OR PRODUCT RESULTING FROM ANY DEFECT IN, OR MALFUNCTION OR FAILURE OF, THIS HITACHI PRODUCT. BECAUSE SOME STATES DO NOT ALLOW LIMITATIONS ON HOW LONG AN IMPLIED WARRANTY LASTS, OR THE EXCLUSION OF INCIDENTAL OR CONSEQUENTIAL DAMAGES, THE ABOVE LIMITATIONS MAY NOT APPLY TO YOU. THIS LIMITED WARRANTY CONFERS SPECIFIC LEGAL RIGHTS, INCLUDING CERTAIN OTHER RIGHTS THAT MAY VARY DEPENDING ON YOUR JURISDICTION.

800.HITACHI (800.448.2244)

Please call 800.HITACHI (800.448.2244) for operational, hook up or warranty service support.

Visit our website at [www.hitachi.us/tv](http://www.hitachi.us/tv) :

Hitachi's website features a wealth of information on Hitachi products and technologies, as well as downloadable owners guides and other useful information.

MODEL NAME	SERIAL NO.
DEALER NAME	DATE OF PURCHASE
DEALER ADDRESS	
CITY	STATE

LIMITED WARRANTY

# End User License Agreement for HITACHI DTV Software

## END USER LICENSE AGREEMENT FOR HITACHI DTV SOFTWARE

**IMPORTANT – READ CAREFULLY:** This End User License Agreement for HITACHI DTV Software (this “Agreement”) is a legal agreement between you (“you” or “your”), in your capacity as the owner of a HITACHI brand digital television (the “DTV”), and HITACHI America, Ltd., Home Electronics Division (“HITACHI”). By using the DTV or the digital television software installed on the DTV (the “DTV Software”) or any Upgrade (as defined below, and together with the DTV Software, the “Software”), you agree to be bound by the terms and conditions of this Agreement. **IF YOU DO NOT AGREE TO BE BOUND BY THIS LICENSE AGREEMENT, DO NOT USE THE DTV OR THE SOFTWARE.**

1. **LICENSE GRANT.** HITACHI grants to you, for the life of the DTV, a non-exclusive, non-transferable, revocable license to install and use one copy of the Software on the DTV, subject to the following limitations and restrictions:
  - a. You may not share, duplicate, republish or redistribute the Software;
  - b. You may not resell, rent, lease, sublicense, gift, loan, as sign or otherwise transfer the Software or any of your rights under this Agreement;
  - c. You may not modify, adapt, translate, reverse engineer, decompile, disassemble or make derivative works from the Software or use the Software in combination with any non-Hitachi software; and
  - d. You may not use the Software for any commercial purpose.
2. **VIOLATIONS; INDEMNITY.** You understand and agree that your use of the Software in any manner except as permitted under this Agreement could constitute a serious crime and could subject you to damages and an award to HITACHI of attorneys’ fees in connection with your violation of this Agreement. You further understand that you may be held legally responsible for any copyright infringement or other violation of intellectual property rights caused or facilitated by your failure to abide by the terms of this Agreement. You agree to defend, indemnify and hold HITACHI and its parent and affiliate companies harmless from and against any and all liability resulting from any breach by you of this Agreement.
3. **INTELLECTUAL PROPERTY.** The Software is protected by federal copyright laws, international copyright treaties and other intellectual property laws and treaties. The Software is licensed, not sold, to you. All right, title and interest in and to the Software and any intellectual property associated therewith, including any accompanying printed materials, shall belong to HITACHI and its licensors and suppliers. Except as expressly provided herein, neither HITACHI nor any of its licensors or suppliers grants to you under this Agreement any express or implied right in or to any patents, copyrights, trademarks, trade secrets or other intellectual property. All right, title and interest in and to the intellectual property rights associated with any content that is accessible through use of the Software shall belong to the applicable content owners and may be protected by copyright or other intellectual property laws and treaties. This Agreement grants you no rights to use such content. Any rights of HITACHI not expressly granted to you hereunder are reserved expressly by Hitachi.
4. **SOFTWARE UPGRADES.** In the future, HITACHI may release or make available one or more upgrades to the DTV Software (each, an “Upgrade”). You understand and agree that if you decide to install or use any Upgrade, your installation and use of such Upgrade and/or any other software or intellectual property HITACHI may provide in connection therewith shall be governed by the terms and conditions of this Agreement, except to the extent that HITACHI provides different or supplementary license terms or conditions that accompany such Upgrade or other software or intellectual property. In the event HITACHI provides you with a “flash card” or other media to effect or facilitate an Upgrade, you understand and acknowledge that your failure to return such flash card or other media to HITACHI as HITACHI may require could result in HITACHI placing your name and your DTV’s serial number on a “No Further Upgrades” list, which will prohibit you from receiving any subsequent Upgrades HITACHI may later release or make available. **IF YOU DO NOT AGREE WITH ALL THE TERMS AND CONDITIONS OF THIS AGREEMENT OR ALL THE TERMS AND CONDITIONS OF ANY DIFFERENT OR SUPPLEMENTARY LICENSE THAT MAY ACCOMPANY SUCH UPGRADE, (A) DO NOT USE ANY HITACHI-PROVIDED FLASH CARD OR OTHER MEDIA, (B) DO NOT PERFORM INSTALL ANY HITACHI-PROVIDED UPGRADE SOFTWARE ON YOUR DTV, AND (C) PROMPTLY RETURN SUCH FLASH CARD OR OTHER MEDIA TO HITACHI.**
5. **EXPORT RESTRICTIONS.** HITACHI is licensing the Software for use within North America only. You agree that you will not export or re-export the Software. You specifically agree not to export or reexport the Software: (i) to any country to which the U.S. has embargoed or restricted the export of goods or services, which currently include, but are not necessarily limited to Cuba, Iran, Libya, North Korea, Sudan and Syria, or to any national of any such country, wherever located, who intends to transmit or transport the Software back to such country; (ii) to any person or entity who you know or have reason to know will utilize the Software in the design, development, or production of nuclear, chemical, or biological weapons; or (iii) to any person or entity who has been prohibited from participating in U.S. export transactions by any federal agency of the U.S.

government. You warrant and represent that neither the U.S. Bureau of Industry and Security nor any other U.S. federal Agency has suspended, revoked, or denied your export privileges.

6. **NO WARRANTIES.** The software is provided to you in “as is” condition and HITACHI makes no warranties of any kind whatsoever regarding the software and, to the maximum extent permitted by law, hereby expressly disclaims all warranties of any kind whatsoever, express or implied, with respect to the software. All implied warranties, including without limitation, the implied warranties of non-infringement, merchantability and fitness for a particular purpose are hereby expressly disclaimed by HITACHI to the maximum extent permitted by law.
7. **LIMITATION OF LIABILITY.** To the maximum extent permitted by applicable law, HITACHI, its licensors, suppliers, parent companies, affiliates, subsidiaries, employees and agents shall not under any circumstances be liable to you or any third parties for any damages of any nature arising in any way from this agreement, your use of the software or otherwise, whether indirect, special, incidental, consequential or otherwise, including, without limitation, any claims for lost profits, lost good will, lost data, business interruption, procurement of substitute goods or services, or expenditures made or committed for in reliance on the continuation of this agreement, even if advised in advance of the possibility of such damages.
8. **NO FAILURE OF ESSENTIAL PURPOSE.** You agree that neither HITACHI’S breach of this agreement nor its failure to repair a defect, error or bug in the software shall constitute a failure of the essential purpose of this agreement.
9. **CRYPTOGRAPHIC SOFTWARE.** The software contains software developed by the OpenSSL Project, including cryptographic software written by eric young (the “cryptographic software”). The cryptographic software is provided by the OpenSSL Project in “as is” condition and any express or implied warranties, including but not limited to, the implied warranties of merchantability and fitness for a particular purpose are hereby expressly disclaimed to the maximum extent permitted by law. In no event shall the OpenSSL Project, its contributors, HITACHI or any of its parent or affiliate companies be liable for any direct, indirect, incidental, special, exemplary, or consequential damages (including, but not limited to, procurement of substitute goods or services; loss of use, data, or profits; or business interruption) however caused and on any theory of liability, whether in contract, strict liability, or tort (including negligence or otherwise) arising in any way out of the use of the software or the cryptographic software, even if advised in advance of the possibility of such damages.
10. **TERMINATION.** HITACHI may terminate this Agreement immediately at any time by providing notice to you.
11. **GOVERNING LAW; SEVERABILITY.** This Agreement will be governed by the laws of the State of New York, and you consent to the exclusive jurisdiction and venue in the federal courts sitting in the Southern District of New York, unless no federal subject matter jurisdiction exists, in which case you consent to the exclusive jurisdiction and venue in the Borough of Manhattan, New York, USA.

# End User License Agreement for Open Source Software

## OPEN SOURCE SOFTWARE LICENSE INFORMATION

This Hitachi TV incorporates open source software modules distributed under certain licenses, including the GNU General Public License Version 3 (as defined by the Free Software Foundation, Inc.).

This Hitachi TV incorporates software based in part on the work of the Independent JPEG Group.

The open source software modules incorporated in this Hitachi TV are shown in the table below:

Software Module	Library Name	Link	Applicable License
AC3 decoder	liba52.c	<a href="http://www.liba52.sourceforge.net">www.liba52.sourceforge.net</a>	GNU General Public License Version 3
PNG decoder	libpng 1.0.2	<a href="http://www.libpng.org/pub/png/libpng.html">www.libpng.org/pub/png/libpng.html</a>	<a href="http://www.libpng.org/pub/png/src/libpng-LICENSE.txt">http://www.libpng.org/pub/png/src/libpng-LICENSE.txt</a>
zlib	Zlib 1.1.3	<a href="http://www.zlib.net">www.zlib.net</a>	<a href="http://www.zlib.net/zlib_license.html">http://www.zlib.net/zlib_license.html</a>
Jpeg decoder	jpeglib	<a href="http://www.iijg.org">www.iijg.org</a>	Download of license (within README file) available at <a href="http://www.iijg.org">www.iijg.org</a> .

THESE SOFTWARE MODULES AND THE SOURCE CODE MODIFICATIONS THERETO ARE PROVIDED "AS IS" AND BOTH THE LICENSORS AND HITACHI DISCLAIM ANY AND ALL WARRANTIES OF ANY KIND, INCLUDING THE IMPLIED WARRANTY OF MERCHANTABILITY AND OF FITNESS FOR A PARTICULAR PURPOSE.

See above links and the GNU General Public License that appears on the following pages of this Owners Guide for additional terms and conditions.

If you would like to learn more about the Free Software Foundation, Inc. or the GNU software project, please visit <http://www.fsf.org>. If you would like to request a copy of the Source Code Modifications, please send an email to the following address: [tvsoftwaresupport@hal.hitachi.com](mailto:tvsoftwaresupport@hal.hitachi.com)

# End User License Agreement for Operating System Software

## TERMS AND CONDITIONS

### 0. Definitions.

"This License" refers to version 3 of the GNU General Public License.

"Copyright" also means copyright-like laws that apply to other kinds of works, such as semiconductor masks.

"The Program" refers to any copyrightable work licensed under this License. Each licensee is addressed as "you". "Licensees" and "recipients" may be individuals or organizations.

To "modify" a work means to copy from or adapt all or part of the work in a fashion requiring copyright permission, other than the making of an exact copy. The resulting work is called a "modified version" of the earlier work or a work "based on" the earlier work.

A "covered work" means either the unmodified Program or a work based on the Program.

To "propagate" a work means to do anything with it that, without permission, would make you directly or secondarily liable for infringement under applicable copyright law, except executing it on a computer or modifying a private copy. Propagation includes copying, distribution (with or without modification), making available to the public, and in some countries other activities as well.

To "convey" a work means any kind of propagation that enables other parties to make or receive copies. Mere interaction with a user through a computer network, with no transfer of a copy, is not conveying.

An interactive user interface displays "Appropriate Legal Notices" to the extent that it includes a convenient and prominently visible feature that (1) displays an appropriate copyright notice, and (2) tells the user that there is no warranty for the work (except to the extent that warranties are provided), that licensees may convey the work under this License, and how to view a copy of this License. If the interface presents a list of user commands or options, such as a menu, a prominent item in the list meets this criterion.

### 1. Source Code.

The "source code" for a work means the preferred form of the work for making modifications to it. "Object code" means any non-source form of a work.

A "Standard Interface" means an interface that either is an official standard defined by a recognized standards body, or, in the case of interfaces specified for a particular programming language, one that is widely used among developers working in that language.

The "System Libraries" of an executable work include anything, other than the work as a whole, that (a) is included in the normal form of packaging a Major Component, but which is not part of that Major Component, and (b) serves only to enable use of the work with that Major Component, or to implement a Standard Interface for which an implementation is available to the public in source code form. A "Major Component", in this context, means a major essential component (kernel, window system, and so on) of the specific operating system (if any) on which the executable work runs, or a compiler used to produce the work, or an object code interpreter used to run it.

The "Corresponding Source" for a work in object code form means all the source code needed to generate, install, and (for an executable work) run the object code and to modify the work, including scripts to control those activities. However, it does not include the work's System Libraries, or general-purpose tools or generally available free programs which are used unmodified in performing those activities but which are not part of the work. For example, Corresponding Source includes interface definition files associated with source files for the work, and the source code for shared libraries and dynamically linked subprograms that the work is specifically designed to require, such as by intimate data communication or control flow between those subprograms and other parts of the work.

The Corresponding Source need not include anything that users can regenerate automatically from other parts of the Corresponding Source.

The Corresponding Source for a work in source code form is that same work.

### 2. Basic Permissions.

All rights granted under this License are granted for the term of copyright on the Program, and are irrevocable provided the stated conditions are met. This License explicitly affirms your unlimited permission to run the unmodified Program. The output from running a covered work is covered by this License only if the output, given its content, constitutes a covered work. This License acknowledges your rights of fair use or other equivalent, as provided by copyright law.

You may make, run and propagate covered works that you do not convey, without conditions so long as your license otherwise remains in force. You may convey covered works to others for the sole purpose of having them make modifications exclusively for you, or provide you with facilities for running those works, provided that you comply with the terms of this License in conveying all material for which you do not control copyright. Those thus making or running the covered works for you must do so exclusively on your behalf, under your direction and control, on terms that prohibit them from making any copies of your copyrighted material outside their relationship with you.

Conveying under any other circumstances is permitted solely under the conditions stated below. Sublicensing is not allowed; section 10 makes it unnecessary.

### 3. Protecting Users' Legal Rights From Anti-Circumvention Law.

No covered work shall be deemed part of an effective technological measure under any applicable law fulfilling obligations under article 11 of the WIPO copyright treaty adopted on 20 December 1996, or similar laws prohibiting or restricting circumvention of such measures.

When you convey a covered work, you waive any legal power to forbid circumvention of technological measures to the extent such circumvention is effected by exercising rights under this License with respect to the covered work, and you disclaim any intention to limit operation or modification of the work as a means of enforcing, against the work's users, your or third parties' legal rights to forbid circumvention of technological measures.

### 4. Conveying Verbatim Copies.

You may convey verbatim copies of the Program's source code as you receive it, in any medium, provided that you conspicuously and appropriately publish on each copy an appropriate copyright notice; keep intact all notices stating that this License and any non-permissive terms added in accord with section 7 apply to the code; keep intact all notices of the absence of any warranty; and give all recipients a copy of this License along with the Program.

You may charge any price or no price for each copy that you convey, and you may offer support or warranty protection for a fee.

### 5. Conveying Modified Source Versions.

You may convey a work based on the Program, or the modifications to produce it from the Program, in the form of source code under the terms of section 4, provided that you also meet all of these conditions:

- a) The work must carry prominent notices stating that you modified it, and giving a relevant date.
- b) The work must carry prominent notices stating that it is released under this License and any conditions added under section 7. This requirement modifies the requirement in section 4 to "keep intact all notices".
- c) You must license the entire work, as a whole, under this License to anyone who comes into possession of a copy. This License will therefore apply, along with any applicable section 7 additional terms, to the whole of the work, and all its parts, regardless of how they are packaged. This License gives no permission to license the work in any other way, but it does not invalidate such permission if you have separately received it.
- d) If the work has interactive user interfaces, each must display Appropriate Legal Notices; however, if the Program has interactive interfaces that do not display Appropriate Legal Notices, your work need not make them do so.

A compilation of a covered work with other separate and independent works, which are not by their nature extensions of the covered work, and which are not combined with it such as to form a larger program, in or on a volume of a storage or distribution medium, is called an "aggregate" if the compilation and its resulting copyright are not used to limit the access or legal rights of the compilation's users beyond what the individual works permit. Inclusion of a covered work in an aggregate does not cause this License to apply to the other parts of the aggregate.

### 6. Conveying Non-Source Forms.

You may convey a covered work in object code form under the terms of sections 4 and 5, provided that you also convey the machine-readable Corresponding Source under the terms of this License, in one of these ways:

- a) Convey the object code in, or embodied in, a physical product (including a physical distribution medium), accompanied by the Corresponding Source fixed on a durable physical medium customarily used for software interchange.
- b) Convey the object code in, or embodied in, a physical product (including a physical distribution medium), accompanied by a written offer, valid for at least three years and valid for as long as you offer spare parts or customer support for that product model, to give anyone who possesses the object code either (1) a copy of the Corresponding Source for all the software in the product that is covered by this License, on a durable physical medium customarily used for software interchange, for a price no more than your reasonable cost of physically performing this conveying of source, or (2) access to copy the Corresponding Source from a network server at no charge.
- c) Convey individual copies of the object code with a copy of the written offer to provide the Corresponding Source. This alternative is allowed only occasionally and noncommercially, and only if you received the object code with such an offer, in accord with subsection 6b.
- d) Convey the object code by offering access from a designated place (gratis or for a charge), and offer equivalent access to the Corresponding Source in the same way through the same place at no further charge. You need not require recipients to copy the Corresponding Source along with the object code. If the place to copy the object code is a network server, the Corresponding Source may be on a different server (operated by you or a third party) that supports equivalent copying facilities, provided you maintain clear directions next to the object code saying where to find the Corresponding Source. Regardless of what server hosts the Corresponding Source, you remain obligated to ensure that it is available for as long as needed to satisfy these requirements.

# End User License Agreement for Operating System Software

- e) Convey the object code using peer-to-peer transmission, provided you inform other peers where the object code and Corresponding Source of the work are being offered to the general public at no charge under subsection 6d.

A separable portion of the object code, whose source code is excluded from the Corresponding Source as a System Library, need not be included in conveying the object code work.

A "User Product" is either (1) a "consumer product", which means any tangible personal property which is normally used for personal, family, or household purposes, or (2) anything designed or sold for incorporation into a dwelling. In determining whether a product is a consumer product, doubtful cases shall be resolved in favor of coverage. For a particular product received by a particular user, "normally used" refers to a typical or common use of that class of product, regardless of the status of the particular user or of the way in which the particular user actually uses, or expects or is expected to use, the product. A product is a consumer product regardless of whether the product has substantial commercial, industrial or non-consumer uses, unless such uses represent the only significant mode of use of the product.

"Installation Information" for a User Product means any methods, procedures, authorization keys, or other information required to install and execute modified versions of a covered work in that User Product from a modified version of its Corresponding Source. The information must suffice to ensure that the continued functioning of the modified object code is in no case prevented or interfered with solely because modification has been made.

If you convey an object code work under this section in, or with, or specifically for use in, a User Product, and the conveying occurs as part of a transaction in which the right of possession and use of the User Product is transferred to the recipient in perpetuity or for a fixed term (regardless of how the transaction is characterized), the Corresponding Source conveyed under this section must be accompanied by the Installation Information. But this requirement does not apply if neither you nor any third party retains the ability to install modified object code on the User Product (for example, the work has been installed in ROM).

The requirement to provide Installation Information does not include a requirement to continue to provide support service, warranty, or updates for a work that has been modified or installed by the recipient, or for the User Product in which it has been modified or installed. Access to a network may be denied when the modification itself materially and adversely affects the operation of the network or violates the rules and protocols for communication across the network.

Corresponding Source conveyed, and Installation Information provided, in accord with this section must be in a format that is publicly documented (and with an implementation available to the public in source code form), and must require no special password or key for unpacking, reading or copying.

## 7. Additional Terms.

"Additional permissions" are terms that supplement the terms of this License by making exceptions from one or more of its conditions. Additional permissions that are applicable to the entire Program shall be treated as though they were included in this License, to the extent that they are valid under applicable law. If additional permissions apply only to part of the Program, that part may be used separately under those permissions, but the entire Program remains governed by this License without regard to the additional permissions.

When you convey a copy of a covered work, you may at your option remove any additional permissions from that copy, or from any part of it. (Additional permissions may be written to require their own removal in certain cases when you modify the work.) You may place additional permissions on material, added by you to a covered work, for which you have or can give appropriate copyright permission.

Notwithstanding any other provision of this License, for material you add to a covered work, you may (if authorized by the copyright holders of that material) supplement the terms of this License with terms:

- a) Disclaiming warranty or limiting liability differently from the terms of sections 15 and 16 of this License; or
- b) Requiring preservation of specified reasonable legal notices or author attributions in that material or in the Appropriate Legal Notices displayed by works containing it; or
- c) Prohibiting misrepresentation of the origin of that material, or requiring that modified versions of such material be marked in reasonable ways as different from the original version; or
- d) Limiting the use for publicity purposes of names of licensors or authors of the material; or
- e) Declining to grant rights under trademark law for use of some trade names, trademarks, or service marks; or
- f) Requiring indemnification of licensors and authors of that material by anyone who conveys the material (or modified versions of it) with contractual assumptions of liability to the recipient, for any liability that these contractual assumptions directly impose on those licensors and authors.

All other non-permissive additional terms are considered "further restrictions" within the meaning of section 10. If the Program as you received it, or any part of it, contains a notice stating that it is governed by this License along with a term that is a further restriction, you may remove that term. If a license document contains a further restriction but permits relicensing or conveying under this License, you may add to a covered work material governed by the terms of that license document, provided that the further restriction does not survive such relicensing or conveying.

If you add terms to a covered work in accord with this section, you must place, in the relevant source files, a statement of the additional terms that apply to those files, or a notice indicating where to find the applicable terms.

Additional terms, permissive or non-permissive, may be stated in the form of a separately written license, or stated as exceptions; the above requirements apply either way.

## 8. Termination.

You may not propagate or modify a covered work except as expressly provided under this License. Any attempt otherwise to propagate or modify it is void, and will automatically terminate your rights under this License (including any patent licenses granted under the third paragraph of section 11).

However, if you cease all violation of this License, then your license from a particular copyright holder is reinstated (a) provisionally, unless and until the copyright holder explicitly and finally terminates your license, and (b) permanently, if the copyright holder fails to notify you of the violation by some reasonable means prior to 60 days after the cessation.

Moreover, your license from a particular copyright holder is reinstated permanently if the copyright holder notifies you of the violation by some reasonable means, this is the first time you have received notice of violation of this License (for any work) from that copyright holder, and you cure the violation prior to 30 days after your receipt of the notice.

Termination of your rights under this section does not terminate the licenses of parties who have received copies or rights from you under this License. If your rights have been terminated and not permanently reinstated, you do not qualify to receive new licenses for the same material under section 10.

## 9. Acceptance Not Required for Having Copies.

You are not required to accept this License in order to receive or run a copy of the Program. Ancillary propagation of a covered work occurring solely as a consequence of using peer-to-peer transmission to receive a copy likewise does not require acceptance. However, nothing other than this License grants you permission to propagate or modify any covered work. These actions infringe copyright if you do not accept this License. Therefore, by modifying or propagating a covered work, you indicate your acceptance of this License to do so.

## 10. Automatic Licensing of Downstream Recipients.

Each time you convey a covered work, the recipient automatically receives a license from the original licensors, to run, modify and propagate that work, subject to this License. You are not responsible for enforcing compliance by third parties with this License.

An "entity transaction" is a transaction transferring control of an organization, or substantially all assets of one, or subdividing an organization, or merging organizations. If propagation of a covered work results from an entity transaction, each party to that transaction who receives a copy of the work also receives whatever licenses to the work the party's predecessor in interest had or could give under the previous paragraph, plus a right to possession of the Corresponding Source of the work from the predecessor in interest, if the predecessor has it or can get it with reasonable efforts.

You may not impose any further restrictions on the exercise of the rights granted or affirmed under this License. For example, you may not impose a license fee, royalty, or other charge for exercise of rights granted under this License, and you may not initiate litigation (including a cross-claim or counterclaim in a lawsuit) alleging that any patent claim is infringed by making, using, selling, offering for sale, or importing the Program or any portion of it.

## 11. Patents.

A "contributor" is a copyright holder who authorizes use under this License of the Program or a work on which the Program is based. The work thus licensed is called the contributor's "contributor version".

A contributor's "essential patent claims" are all patent claims owned or controlled by the contributor, whether already acquired or hereafter acquired, that would be infringed by some manner, permitted by this License, of making, using, or selling its contributor version, but do not include claims that would be infringed only as a consequence of further modification of the contributor version. For purposes of this definition, "control" includes the right to grant patent sublicenses in a manner consistent with the requirements of this License.

Each contributor grants you a non-exclusive, worldwide, royalty-free patent license under the contributor's essential patent claims, to make, use, sell, offer for sale, import and otherwise run, modify and propagate the contents of its contributor version.

In the following three paragraphs, a "patent license" is any express agreement or commitment, however denominated, not to enforce a patent (such as an express permission to practice a patent or covenant not to sue for patent infringement). To "grant" such a patent license to a party means to make such an agreement or commitment not to enforce a patent against the party.

# End User License Agreement for Operating System Software

If you convey a covered work, knowingly relying on a patent license, and the Corresponding Source of the work is not available for anyone to copy, free of charge and under the terms of this License, through a publicly available network server or other readily accessible means, then you must either (1) cause the Corresponding Source to be so available, or (2) arrange to deprive yourself of the benefit of the patent license for this particular work, or (3) arrange, in a manner consistent with the requirements of this License, to extend the patent license to downstream recipients. "Knowingly relying" means you have actual knowledge that, but for the patent license, your conveying the covered work in a country, or your recipient's use of the covered work in a country, would infringe one or more identifiable patents in that country that you have reason to believe are valid.

If, pursuant to or in connection with a single transaction or arrangement, you convey, or propagate by procuring conveyance of, a covered work, and grant a patent license to some of the parties receiving the covered work authorizing them to use, propagate, modify or convey a specific copy of the covered work, then the patent license you grant is automatically extended to all recipients of the covered work and works based on it.

A patent license is "discriminatory" if it does not include within the scope of its coverage, prohibits the exercise of, or is conditioned on the non-exercise of one or more of the rights that are specifically granted under this License. You may not convey a covered work if you are a party to an arrangement with a third party that is in the business of distributing software, under which you make payment to the third party based on the extent of your activity of conveying the work, and under which the third party grants, to any of the parties who would receive the covered work from you, a discriminatory patent license (a) in connection with copies of the covered work conveyed by you (or copies made from those copies), or (b) primarily for and in connection with specific products or compilations that contain the covered work, unless you entered into that arrangement, or that patent license was granted, prior to 28 March 2007.

Nothing in this License shall be construed as excluding or limiting any implied license or other defenses to infringement that may otherwise be available to you under applicable patent law.

## 12. No Surrender of Others' Freedom.

If conditions are imposed on you (whether by court order, agreement or otherwise) that contradict the conditions of this License, they do not excuse you from the conditions of this License. If you cannot convey a covered work so as to satisfy simultaneously your obligations under this License and any other pertinent obligations, then as a consequence you may not convey it at all. For example, if you agree to terms that obligate you to collect a royalty for further conveying from those to whom you convey the Program, the only way you could satisfy both those terms and this License would be to refrain entirely from conveying the Program.

## 13. Use with the GNU Affero General Public License.

Notwithstanding any other provision of this License, you have permission to link or combine any covered work with a work licensed under version 3 of the GNU Affero General Public License into a single combined work, and to convey the resulting work. The terms of this License will continue to apply to the part which is the covered work, but the special requirements of the GNU Affero General Public License, section 13, concerning interaction through a network will apply to the combination as such.

## 14. Revised Versions of this License.

The Free Software Foundation may publish revised and/or new versions of the GNU General Public License from time to time. Such new versions will be similar in spirit to the present version, but may differ in detail to address new problems or concerns.

Each version is given a distinguishing version number. If the Program specifies that a certain numbered version of the GNU General Public License "or any later version" applies to it, you have the option of following the terms and conditions either of that numbered version or of any later version published by the Free Software Foundation. If the Program does not specify a version number of the GNU General Public License, you may choose any version ever published by the Free Software Foundation.

If the Program specifies that a proxy can decide which future versions of the GNU General Public License can be used, that proxy's public statement of acceptance of a version permanently authorizes you to choose that version for the Program.

Later license versions may give you additional or different permissions. However, no additional obligations are imposed on any author or copyright holder as a result of your choosing to follow a later version.

## 15. Disclaimer of Warranty.

THERE IS NO WARRANTY FOR THE PROGRAM, TO THE EXTENT PERMITTED BY APPLICABLE LAW. EXCEPT WHEN OTHERWISE STATED IN WRITING THE COPYRIGHT HOLDERS AND/OR OTHER PARTIES PROVIDE THE PROGRAM "AS IS" WITHOUT WARRANTY OF ANY KIND, EITHER EXPRESSED OR IMPLIED, INCLUDING, BUT NOT LIMITED TO, THE IMPLIED WARRANTIES OF MERCHANTABILITY AND FITNESS FOR A PARTICULAR PURPOSE. THE ENTIRE RISK AS TO THE QUALITY AND PERFORMANCE OF THE PROGRAM IS WITH YOU. SHOULD THE PROGRAM PROVE DEFECTIVE, YOU ASSUME THE COST OF ALL NECESSARY SERVICING, REPAIR OR CORRECTION.

## 16. Limitation of Liability.

IN NO EVENT UNLESS REQUIRED BY APPLICABLE LAW OR AGREED TO IN WRITING WILL ANY COPYRIGHT HOLDER, OR ANY OTHER PARTY WHO MODIFIES AND/OR CONVEYS THE PROGRAM AS PERMITTED ABOVE, BE LIABLE TO YOU FOR DAMAGES, INCLUDING ANY GENERAL, SPECIAL, INCIDENTAL OR CONSEQUENTIAL DAMAGES ARISING OUT OF THE USE OR INABILITY TO USE THE PROGRAM (INCLUDING BUT NOT LIMITED TO LOSS OF DATA OR DATA BEING RENDERED INACCURATE OR LOSSES SUSTAINED BY YOU OR THIRD PARTIES OR A FAILURE OF THE PROGRAM TO OPERATE WITH ANY OTHER PROGRAMS), EVEN IF SUCH HOLDER OR OTHER PARTY HAS BEEN ADVISED OF THE POSSIBILITY OF SUCH DAMAGES.

## 17. Interpretation of Sections 15 and 16.

If the disclaimer of warranty and limitation of liability provided above cannot be given local legal effect according to their terms, reviewing courts shall apply local law that most closely approximates an absolute waiver of all civil liability in connection with the Program, unless a warranty or assumption of liability accompanies a copy of the Program in return for a fee.

# Appendixes

## Appendix A: Picture Format for Each Input Source

Aspect Specifications

Yes: Available / --: Not Available

Input Signal			Aspect					
			Auto	4:3	16:9	Full	Zoom1	Zoom2
AIR / CABLE	Air / Cable		Yes	Yes	Yes	--	Yes	Yes
HDMI 1	HDMI	1080p, 1080i, 720p, 480p, 480i	Yes	Yes	Yes	Yes	Yes	Yes
HDMI 2	HDMI / DVI	1080p, 1080i, 720p, 480p, 480i	Yes	Yes	Yes	Yes	Yes	Yes
		640x480, 800x600, 1024x768, 1280x720, 1280x768, 1280x1024, 1440x900, 1680x1050	Yes	--	--	Yes	--	--
HDMI 3	HDMI	1080p, 1080i, 720p, 480p, 480i	Yes	Yes	Yes	Yes	Yes	Yes
HDMI 4	HDMI	1080p, 1080i, 720p, 480p, 480i	Yes	Yes	Yes	Yes	Yes	Yes
COMPONENT 1	YPbPr		Yes	Yes	Yes	--	Yes	Yes
COMPONENT 2	YPbPr		Yes	Yes	Yes	--	Yes	Yes
AV 1	Video / S-Video		--	Yes	Yes	--	Yes	Yes
AV 2	Video / S-Video		--	Yes	Yes	--	Yes	Yes
RGB	Analog RGB		Yes	--	--	Yes	--	--

## Appendix B: RGB Format

Resolution	Frequency(Hz)	Resolution	Frequency(Hz)
640x480	60, 72, 75	1280x1024	60
720x400	70	1440x900	60
800x600	56, 60, 72, 75	1680x1050	60
1024x768	60, 70, 75	1920x1080	60
1280x720	60		
1280x768	60		

The type of video board or connecting cable may not allow for correct displays adjustment of H-Position, V-Position, Clock and Phase.

# Index

---

## A

Accessories	6
Add Channels to List	40
Analog Captions	37
Antenna Connection	12
Aspect Ratio	20, 31, 32, 55
Audio Language	33
Audio Settings	33
Audio Source	33
Auto Movie	31

## B

Backlight	31
Balance	33
Bass	33
Brightness	31

## C

Caution and Safety Tips	2-5
Channel List	40
Channel Labels	41
Calibration Menu	30
White Balance	30
Closed Captions	37
Color	31
Color Temp.	31
CONEQ	33
CONEQ 3D Sound	33
Contrast	31
Component Options	39

## D

Day/Night Timer	34
Digital Captions	37
Digital Caption Options	37
Digital Output	33

## E

Energy Options	37
End User Licence Agreement	50-54
External Video Sources	14-17

## F

Favorite Channels	41
Features	45

## G

Game Mode	30
Gamma	31

## H

HDMI	14, 15, 17
HDMI-CEC	38

## I

Input Setup	38
Internal Speakers	33

## L

Light Control	37
---------------	----

## M

Menu Language	34
MPEG NR	31
Multimedia	41

## N

New Channel Scan	40
Noise Reduction	31

## P

Parental Controls	
Set Password	34
Block Unrated Channel	35
Panel Lock	35
Movie Ratings	35
TV Ratings	35
TV Ratings (Canadian - English)	36
TV Ratings (Canadian - French)	36
Region 5 (Downloadable VChip)	36
Preferred Language	33
Perfect Volume	33
Picture Mode	30
Pro Mode	30

## R

Reel120 Motion	31
Remote Control	
Functions	18-27
Installing Batteries	6
Reset (Video)	32
Reset (Audio)	33
Reset (AV& Setup)	39
RGB Options	39

## S

Service Information	48
Set Dimensions	46-47
Set Password	34
Setup	34-39
Sharpness	31
Signal Strength	40
Sleep Timer	34
Sound Mode	33
Source	40
Specifications	45-47

## T

Time	34
Tint	31
Transparency	38
Treble	33
Troubleshooting	42-44

## V

Video Settings	30-32
----------------	-------