

Use and Care Guide



18.5" Square Charcoal Grill

Kmart Item No. 680-02701243-4

This Grill is for Outdoor Use Only

SAVE THESE INSTRUCTIONS!



	WARNING	
<ul style="list-style-type: none">• Read and follow all Safety, Assembly, and Use and Care Instructions in this Guide before assembling and cooking with this grill.• Failure to follow all instructions in this Use and Care Guide may lead to fire or explosion, which could result in property damage, personal injury or death.		

- Safety
- Parts
- Use and Care
- Assembly

Assembly Questions?
Call 1-866-561-0731

Tools needed for assembly:

Screwdriver (not provided)
Open end wrench (not provided)

Sears, Roebuck and Co., Hoffman Estates, IL 60179 U.S.A.
See our extensive assortment of outdoor living products on-line at
www.sears.com and www.kmart.com

BBQ-PRO Charcoal Grill Assembly Instructions

Tips and Features for safety and ease of use

Verify that all parts are included with your grill before beginning assembly by checking the Parts List inside. If all parts are not included, please e-mail us at customerservice@vldgus.com or call us toll free 1-866-561-0731 (M-F 8:30 - 4:30) CT.

USE DIAGRAM(S) PROVIDED FOR ASSEMBLY. Leave nuts half-tightened on the grill during assembly until unit is completely assembled, then finish tightening nuts.









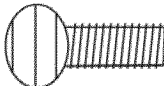

SAFETY GUIDELINES

- This grill is intended for **HOUSEHOLD OUTDOOR USE ONLY**. Do not attempt to use grill in enclosed areas or under an overhead cover of any kind, including a tent or patio cover.
Your grill should never be used closer than 36 inches from walls on the back and side(s) of grill.
- Place your grill outdoors on a firm, level surface. Do not use this grill on a surface that will burn or melt, such as a plastic or artificial surface or wood table. Keep grill away from wooden fences, overhanging trees, or other flammable objects before adding and lighting charcoal.
- DO NOT USE GASOLINE, ALCOHOL OR KEROSENE IN THIS GRILL.** Use only commercial charcoal lighter fluid with charcoal briquettes or pre-soaked charcoal briquettes. Prepare charcoal according to the product's instructions. Do not exceed 3 lbs of charcoal briquettes in this grill per use.
- After lighting charcoal, do not leave grill unattended.
- Remember to keep children and pets away from lit grill at all times.
- To avoid harm to people, pets, or property, do not move the grill once the charcoal has been lit.
- Once coals are lit, the grill and surrounding surfaces become very hot. Use proper outdoor cooking mitts, utensils and avoid skin contact with all hot surfaces on grill.
- To extinguish charcoal after cooking, douse coals with sand or spray with a fine mist of water.
- After your grill has cooled, remove ashes from the catcher and cover, and store the grill when not in use.



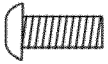





WARNING! Combustion by-products produced when using this product contain chemicals known to the State of California to cause cancer, birth defects, and other reproductive harm.

HARDWARE LIST

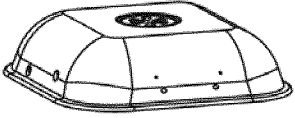
1: (4pcs) 1/4"x 1-1/2" Leg Bolt		7: (6pcs) 3/16" Winged Nut	
2: (4pcs) 1/4" x 5/8" Handle Bolt		8: (2pcs) 5/16" Locknut	
3: (4pcs) 3/16" x 3/8" Bolt		9: (21pcs) 1/4" Fiber Washer	
4: (2pcs) 3/16" x 3/8" Bolt		10: (8pcs) 1/4" Metal Washer	
5: (1pc) 5/32" x 3/8" Damper Bolt		11: (2pcs) 5/16" plastic Washer	
6: (1pc) 5/32" Damper Winged Nut			

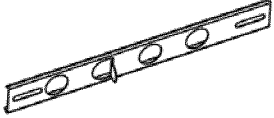
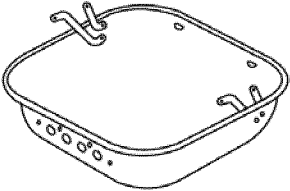
BBQ-PRO Charcoal Grill Assembly Instructions

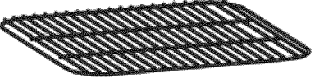
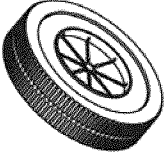
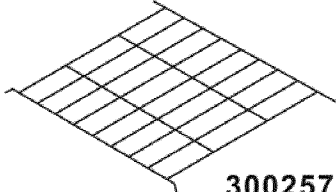
PARTS LIST

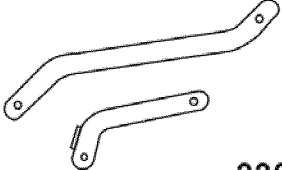
<p>A: Top Lid (1)</p>  <p>200450N</p>	<p>E: Wheel Leg (2)</p>  <p>300254N</p>	<p>I: Bottom Bowl Damper (1)</p>  <p>220105N</p>
<p>B: Bottom Bowl (1)</p>  <p>210307N</p>	<p>F: Lid Vent (1)</p>  <p>300255N</p>	<p>J: Handle (2)</p>  <p>220010N</p>
<p>C: Cooking Grid (1)</p>  <p>300529N</p>	<p>G: Wheel (2)</p>  <p>500200N</p>	<p>K: Wire Rack (Leg Support) (1)</p>  <p>300257N</p>
<p>D: Stationary Leg (2)</p>  <p>300253N</p>	<p>H: Leg Bowl (4)</p>  <p>220200N</p>	<p>L: L&S Hinge (2 each) (Pre-assembled on Bottom Bowl)</p>  <p>220600N</p>

BBQ-PRO Charcoal Grill Assembly Instructions

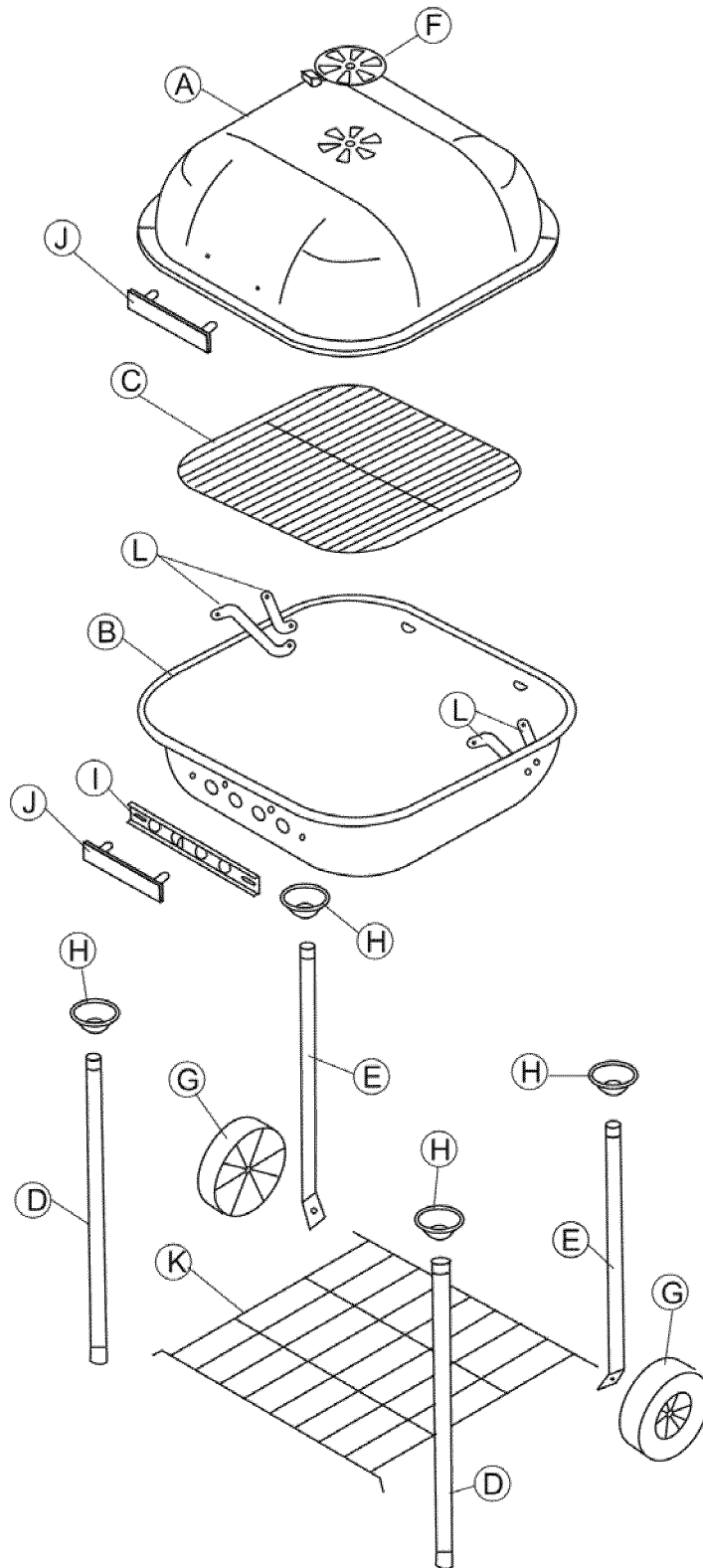

BBQ-PRO Charcoal Grill Assembly Instructions

Remove all the parts from the carton and lay them out on a smooth, clean surface. Verify the presence of all parts by comparing to Hardware and Parts Lists on previous pages. Do not throw away any of the packaging until you locate all the parts.

STEP 1: Attach lid vent (F) to lid (A) by using damper bolt (5), fiber washer (9) and damper winged nut (6).

Attach handle (J) to lid (A) by using 2 handle bolts (2), 2 metal washers (10) and 4 fiber washers (9). Screw handle bolts (2) into handle (J).

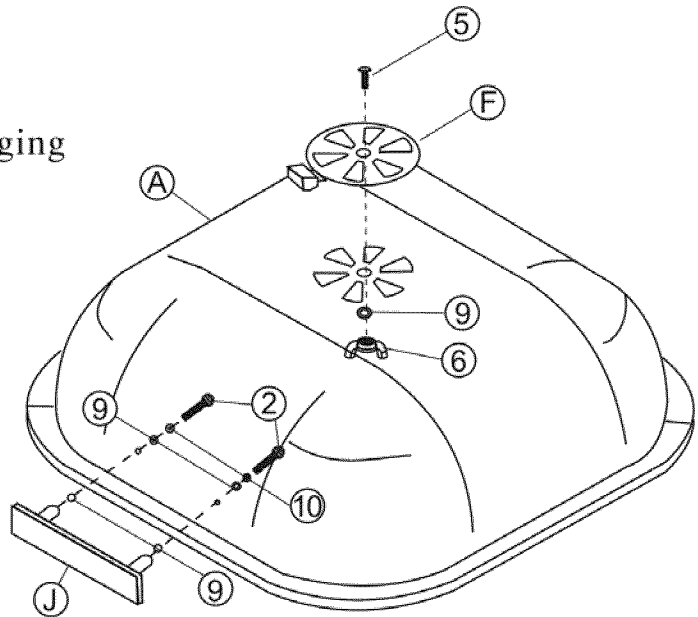

STEP 2: Before attaching the legs make sure that the bottom bowl (B) is facing in the proper position. You want to make sure you place the stationary legs (D) on the opposite side of the bottom bowl (B) away from the hinges (L). See diagram.

Attach stationary legs (D) of grill by inserting a leg bolt (1) through metal washer (10), bottom bowl (B), leg bowl (H), and screwing bolt (1) into stationary leg (D). Repeat procedure for the other stationary leg. Hand tighten.

Attach wheel legs (E) of grill by inserting a leg bolt (1) through metal washer (10), bottom bowl (B), leg bowl (H), and screwing bolt (1) into wheel leg (E). Repeat procedure for the other wheel leg. Hand tighten.

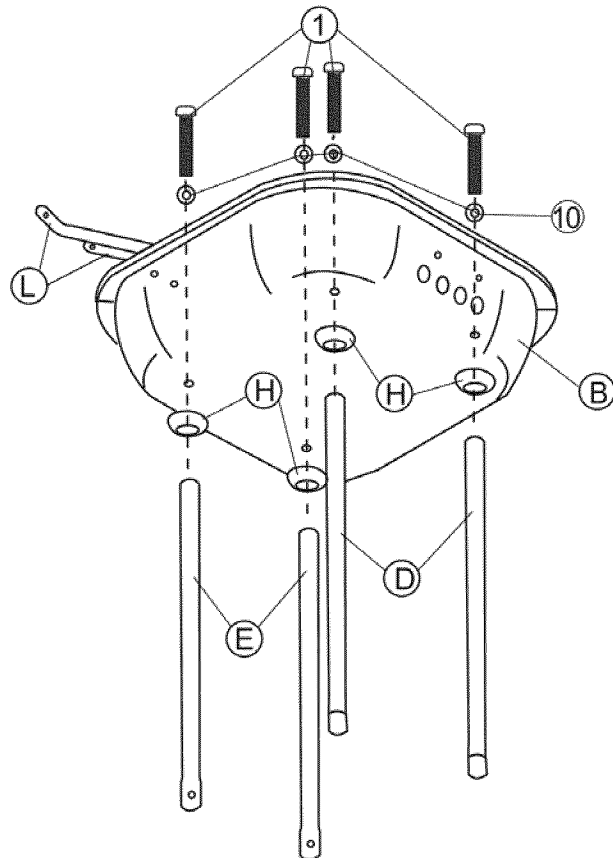

BBQ-PRO Charcoal Grill Assembly Instructions

STEP 3: Before attaching wire rack (K) make sure that the short axles are facing the front. Attach wire rack (K) to stationary legs (D) by inserting the short axles of wire rack (K) through holes in front legs (D).

Attach wire rack (K) to wheel legs (E) by inserting the long axles of wire rack (K) through wheel legs (E), 2 wheels (G), 2 plastic washers (11) and screw 2 locknuts (8).

Tighten all leg bolts and wheel axle nuts

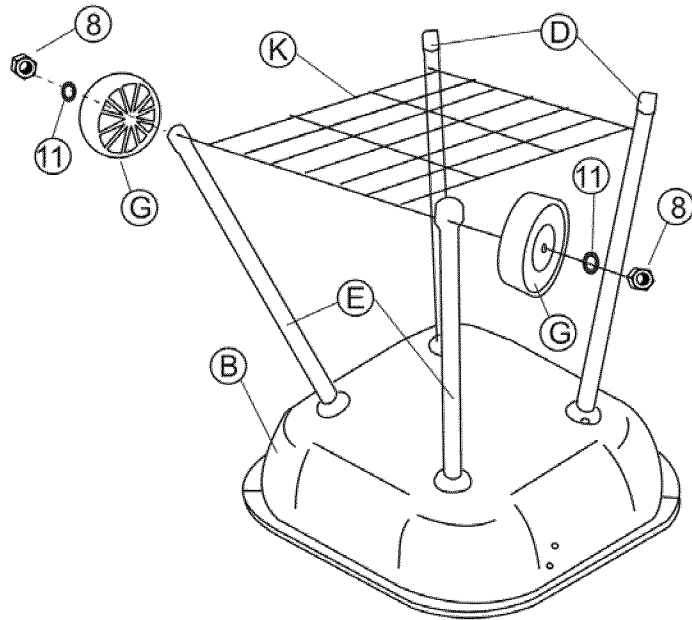

STEP 4: Attach bottom bowl damper (I) to the front of bottom bowl (B). Make sure that the small handle on the bottom bowl damper (I) is facing away from the bottom bowl (B). For the bottom bowl damper (I) use 2 bowl damper bolts (4), 4 fiber washers (9) and 2 winged nuts (7). Make sure when tightening that the bottom bowl damper (I) can move side to side.

Attach handle (J) to bottom bowl (B) by using two handle bolts (2), two metal washers (10) and 4 fiber washers (9). Tighten handle bolts (2) into handle (J).

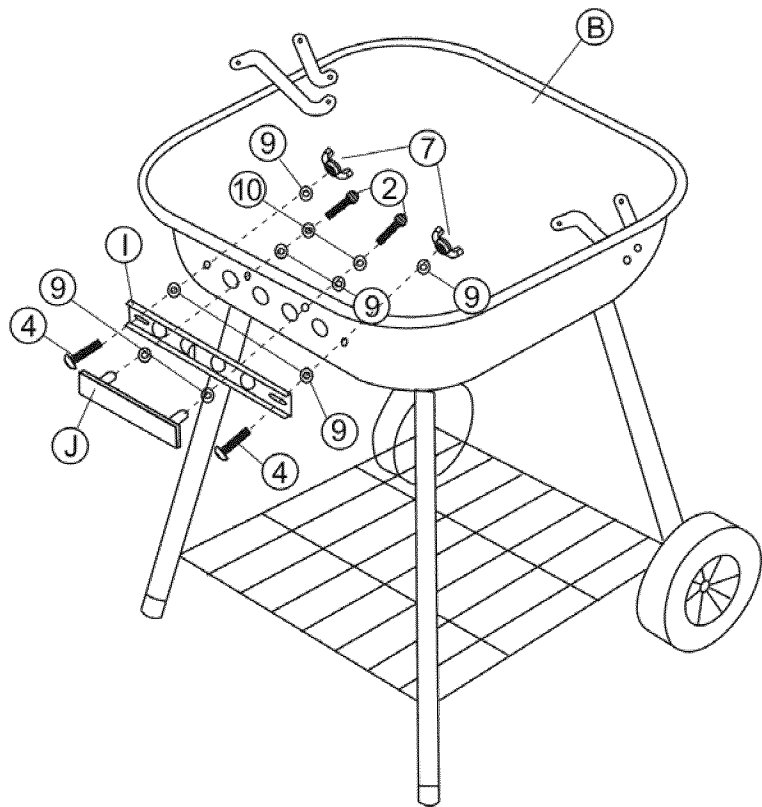

BBQ-PRO Charcoal Grill Assembly Instructions

STEP 6: Pull the preassembled hinges (L) up from inside the bottom bowl (B). Lean the top lid (A) against the rear of the bottom bowl (B). Make sure the hinges (L) are inside the top lid (A). Work with the hinge (L) side closest to you. Line up the bottom hole on the side of the top lid (A) with the hole on the "L" shaped hinge (L) insert a hinge bolt (3), through the top lid (A), a fiber washer (9), the "L" shaped hinge (L), a fiber washer (9), and attach a winged nut (7) to the hinge bolt (3). Repeat same procedure on the other side. Through the top hole insert another hinge bolt (3), through the top lid (A), fiber washer (9), the "S" shaped hinge (L), another fiber washer (9) and attach another winged nut (7) to the hinge bolt (3). Repeat same procedure on other side. Hand tighten only for easy movement.

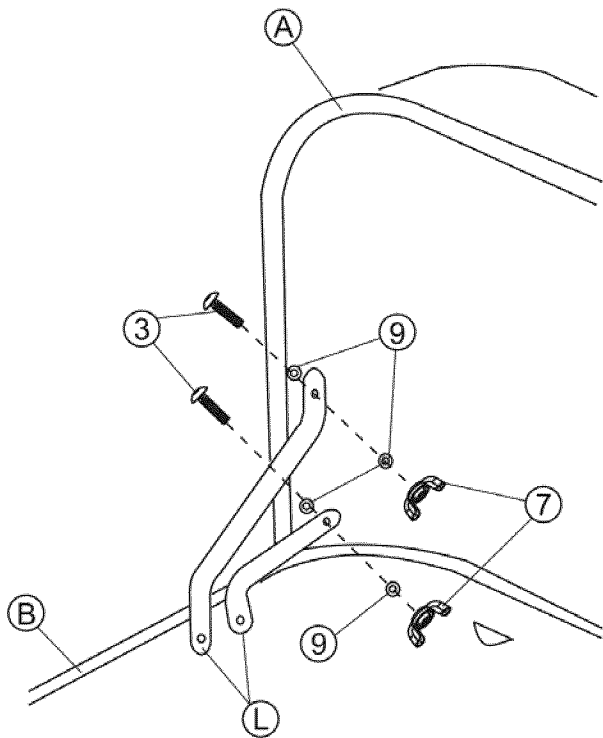

STEP 6: Place cooking grid (C) into bottom bowl (B).

STEP 7: Fully tighten all nuts & screws at this time.

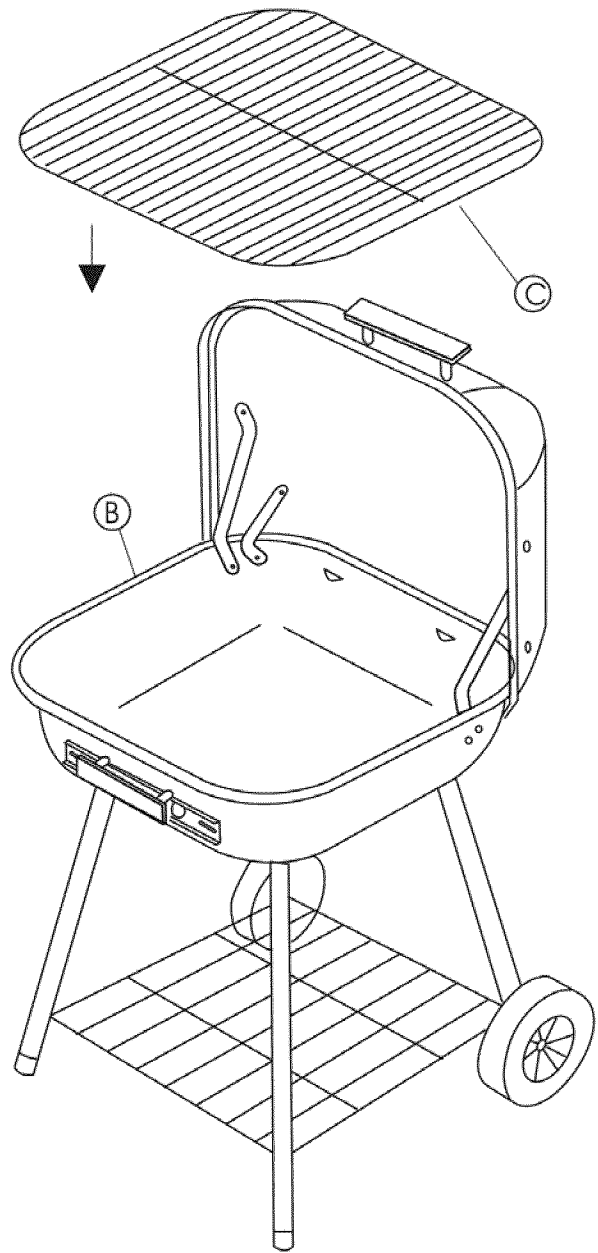

BBQ-PRO Charcoal Grill Assembly Instructions

ORDER PARTS

KEY#	QUANTITY	DESCRIPTION	PART#
A	1	TOP LID	200450N
B	1	BOTTOM BOWL	210307N
C	1	COOKING GRID	300529N
D	2	STATIONARY LEG	300253N
E	2	WHEEL LEG	300254N
F	1	LID VENT	300255N
G	2	WHEEL	500200N
H	4	LEG BOWL	220200N
I	1	BOTTOM BOWL DAMPER	220105N
J	2	HANDLE	220010N
K	1	WIRE RACK (LEG SUPPORT)	300257N
L	2 SETS	L & S HINGE	220600N
1-11	1	HARDWARE PACK	

WARNING: To ensure that it is safe to eat, food must be cooked to the minimum internal temperatures listed in the table below.

USDA* Safe Minimum Internal Temperatures	
Fish	145° F
Pork	160° F
Egg Dishes	160° F
Steaks and Roasts of Beef, Veal or Lamb	145° F
Ground Beef, Veal or Lamb	160° F
Whole Poultry (Turkey, Chicken, Duck, etc.)	165° F
Ground or Pieces Poultry (Chicken Breast, etc.)	165° F

*United States Department of Agriculture

90 Day Limited Warranty

If this BBQ-Pro product fails due to a defect in material or workmanship within 90 days from the date of purchase, return it to any Kmart store or other BBQ-Pro outlet in the United States with your proof of purchase for free replacement.

This warranty gives you specific legal rights, and you may also have other rights which vary from state to state.

Sears, Roebuck and Co., Hoffman Estates, IL 60179

For further information, contact the manufacturer, toll free at 1-866-561-0731.