

HOOVER™

SpinSweep™ Outdoor Sweeper

Owner's Manual

English → pp. 1-8

Español → pàg. 9-12

Français → p. 13-16

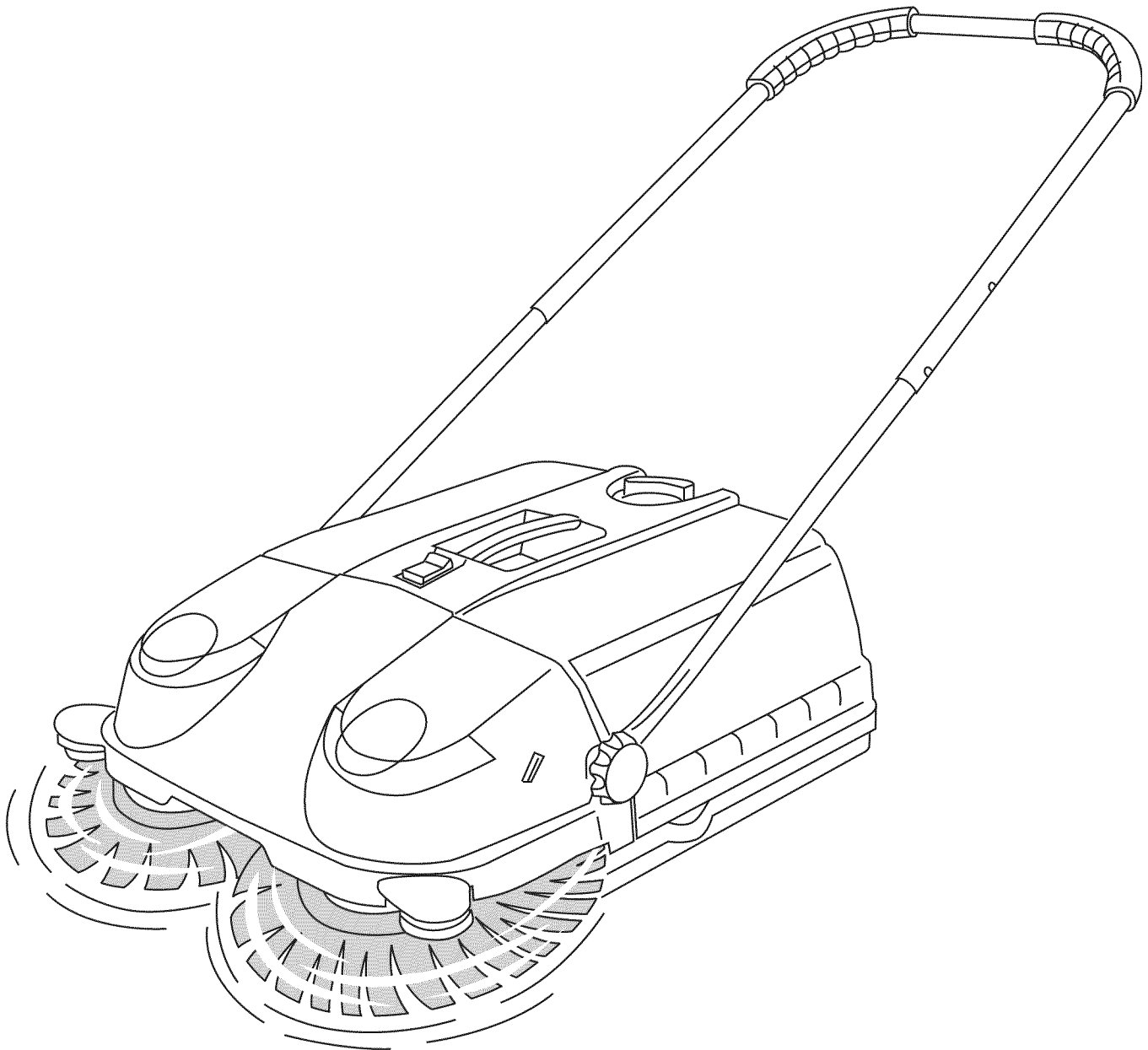

TM

Review this manual before operating sweeper

Thank you for choosing a HOOVER product.

Please enter the COMPLETE model and serial numbers in the spaces provided. The numbers are located on the bottom of your outdoor sweeper.

Model _____

Serial number _____

Hint: Attach your sales receipt to this owner's manual.

Verification of date of purchase may be required for warranty service of your HOOVER product.

Be sure to fill out and return the product registration card included with your outdoor sweeper (see back cover).

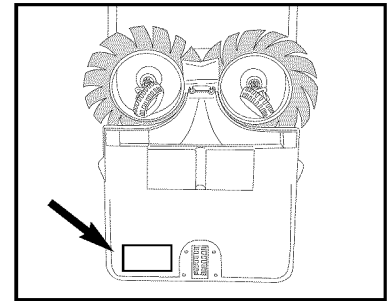

Contents

Important Safeguards	2
Carton Contents	3
Assembly	3-4
How to Use.....	4
Maintenance.....	6
If You Have a Problem	7
Service.....	8
Warranty.....	8

Important Safeguards!

When using any equipment, always follow basic precautions, including the following:

READ ALL INSTRUCTIONS BEFORE USING THIS PRODUCT

Warning:

To reduce the risk of fire, electric shock or injury:

- Close supervision is necessary when any equipment is used by or near children. Do not allow outdoor sweeper to be used as a toy.
- Keep hair, loose clothing, fingers, feet and all parts of body away from openings and moving parts. Do not operate outdoor sweeper in bare feet or when wearing open toe shoes or sandals.
- Do not use to pick up anything that is burning or smoking, such as cigarettes, matches, or hot ashes.
- Do not use to pick up flammable, combustible, explosive, toxic, carcinogenic or other materials and liquids dangerous to health.
- To avoid injury, use heavy gloves when removing glass, metal or similar material from dirt bin.
- Do not use the outdoor sweeper near heat sources such as fire, fan heaters, or other heat dissipating devices.
- Do not sweep over electrical cords.
- Use outdoor sweeper only for its intended use as described in the instructions. Use only attachments recommended by The Hoover Company; others may cause hazards.

Save these instructions!

If you need any assistance:

Visit our website at www.hoover.com. Click on the "Service" button to find the service outlet nearest you.

Please do not return this product to the store.

1. Assembly

Carton contents

- A. Lower handle sections (2)
- B. Top handle section
- C. Outdoor sweeper

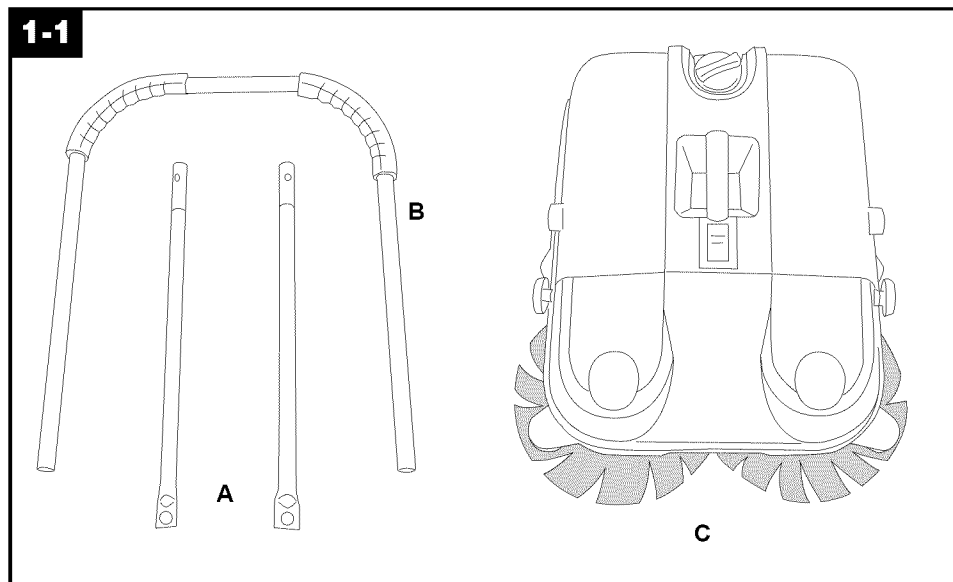

Assemble handle

Insert round end of straight lower handle sections (A) into each side of upper handle section (B).

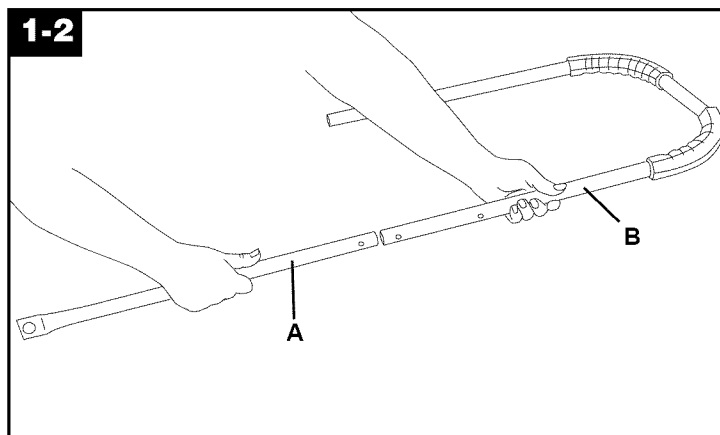

Press button (C) on lower handle section. Slide lower section into upper handle until button snaps into one of the holes (D).

Select upper holes for a shorter handle or lower holes for a longer handle.

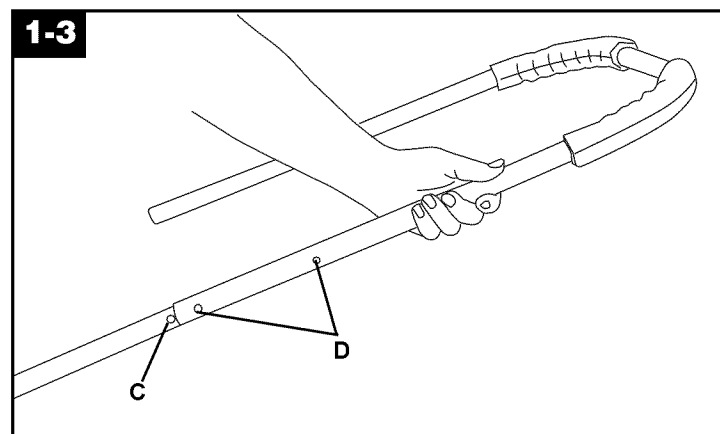

Attach handle

Unscrew handle knobs (E) from each side of sweeper.

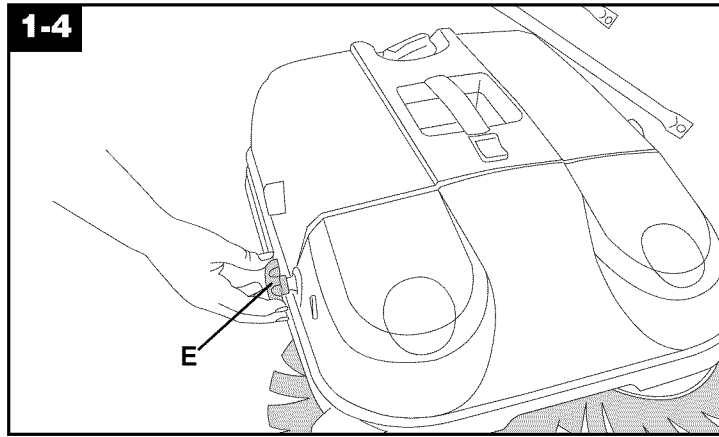

Fit holes on handle onto screw posts (F).

Reattach knobs and twist to tighten.

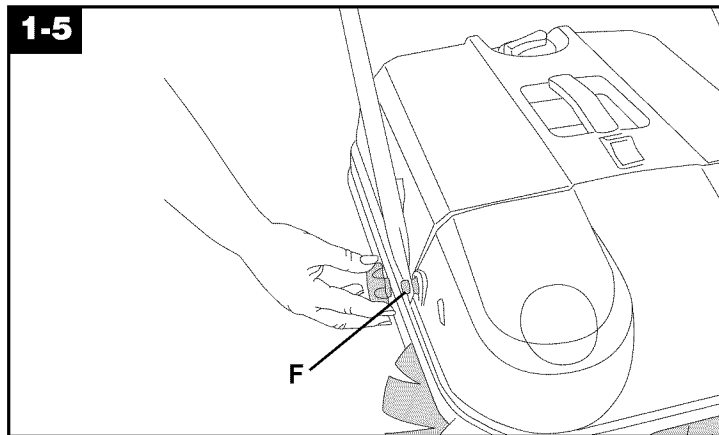

2. How to use

Sweeper description

1. Handle
2. Handle knobs
3. Dirt bin
4. Height adjustment
5. Dirt bin handle
6. Dirt bin release button
7. SpinSweep™ brushes
8. Wall guides

This outdoor sweeper is not intended for heavy commercial use.

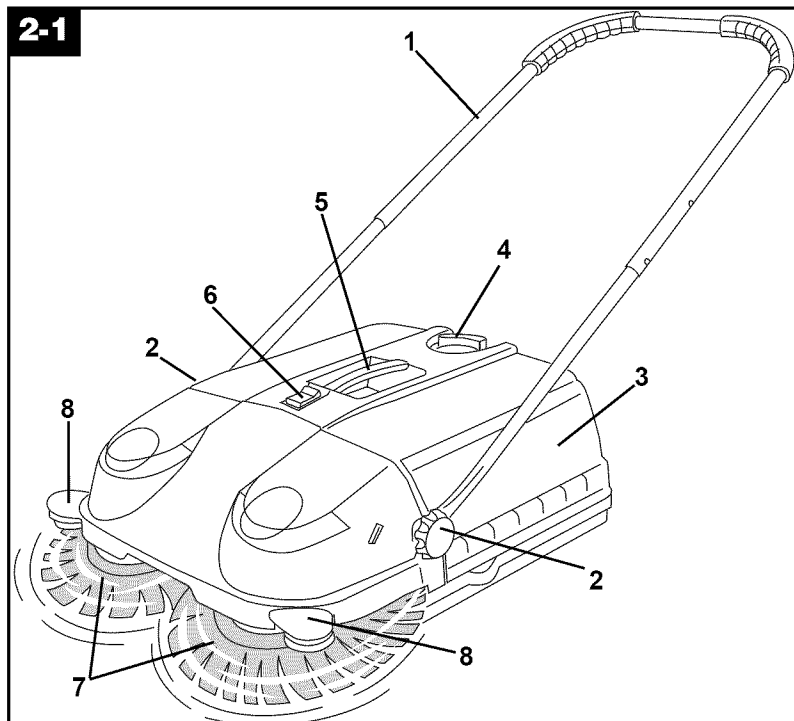

The outdoor sweeper is designed for use on hard, flat surfaces. It is not intended to be used for wet pick up or on lawns. Do not use outdoor sweeper on steps.

The brushes rotate and sweep up debris when the sweeper is pushed forward.

For best results, push the outdoor sweeper at a normal walking pace.

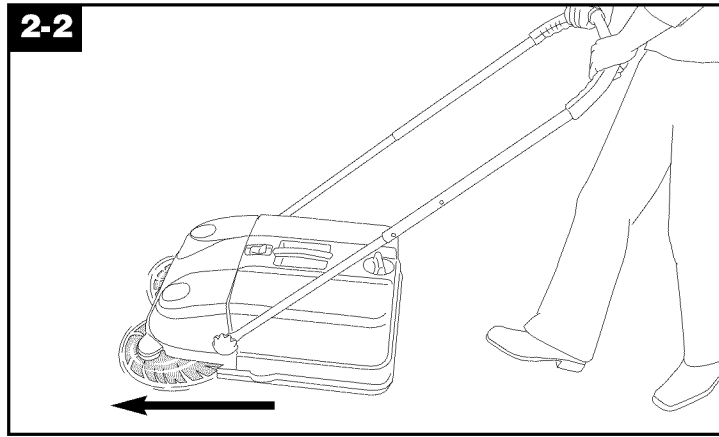

Brush height adjustment

Turn the height adjustment control (A) toward "HIGH" to raise the brushes. (The rear of the sweeper will move to a lower position.) Turn it towards "LOW" to lower the brushes. (The rear of the sweeper will move to a higher position.)

The settings

LOW - for smooth surfaces and picking up debris that is small in size.

HIGHER settings - for rougher surfaces, such as brick and asphalt, or for picking up larger debris.

If the sweeper is difficult to push on a surface, turn the height adjustment toward "HIGH".

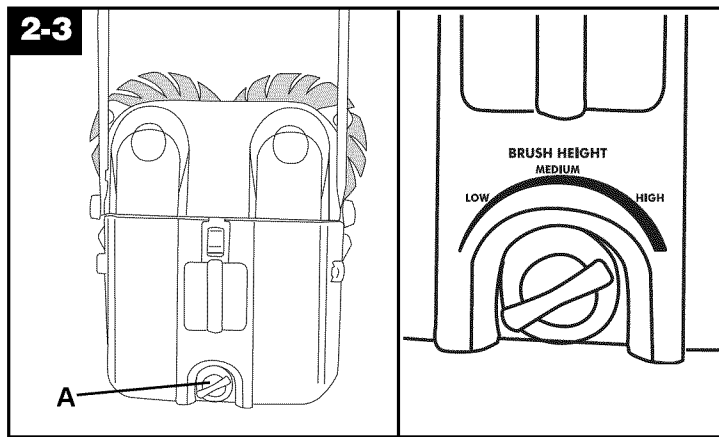

Wall guides

Wall guides are provided on each side of the sweeper to aid in sweeping close to walls or edges.

Guide either side of sweeper along walls.

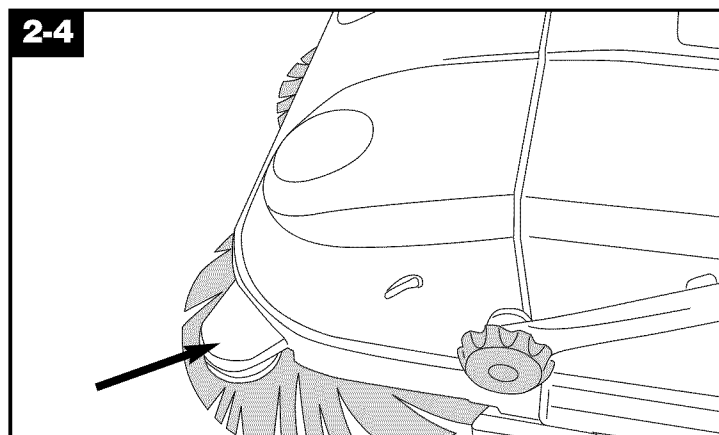

3. Maintenance

Familiarize yourself with these home maintenance tasks, as proper use and care of your outdoor sweeper will ensure continued cleaning ability.

Dirt bin

When to empty

It is recommended that the dirt bin be emptied after every use.

How to empty

Slide dirt bin release (A) toward rear of sweeper.

Lift on handle (B) and remove bin.

Empty bin in an approved trash receptacle. If needed, clean the bin and exterior of sweeper with water and mild detergent. **Do not use any solvent-based cleansers.**

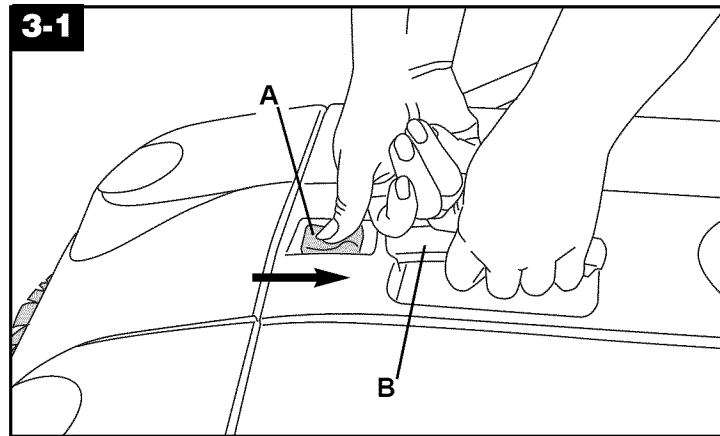

To replace dirt bin, align indent (C) on bin over height adjustment (D).

Lower bin onto sweeper and snap in place.

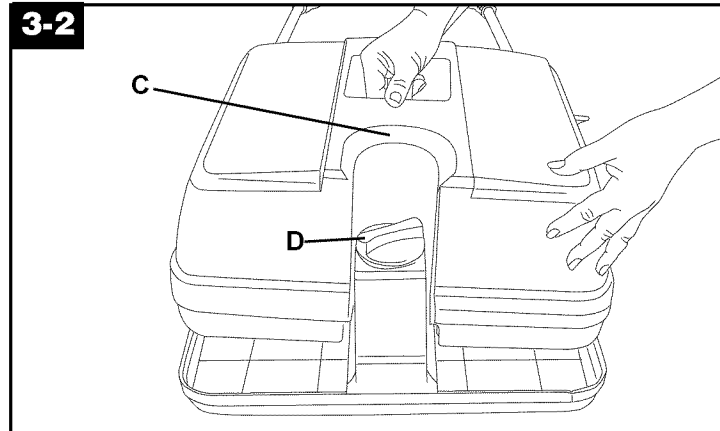

The brushes

Clean brushes with water and mild detergent. Do not use high pressure water spray to clean the brushes.

New brushes can be installed by your local Hoover Service Center.

Storage

Loosen handle knobs and rotate handle toward the brushes and past the “stoppers” (E). Tighten the handle knobs.

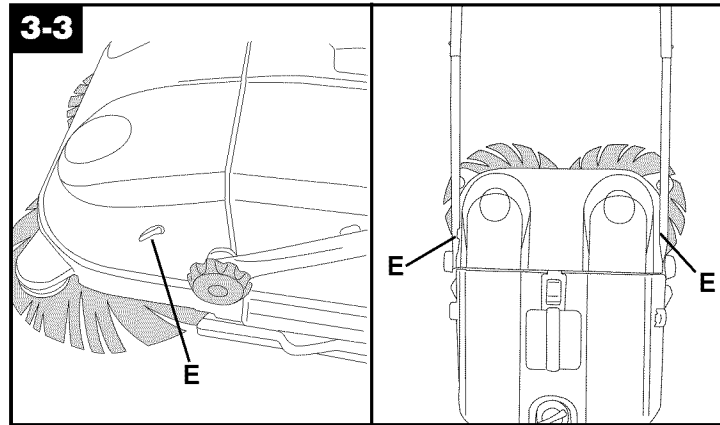

Store the outdoor sweeper either standing upright or hanging.

Store in a dry place.

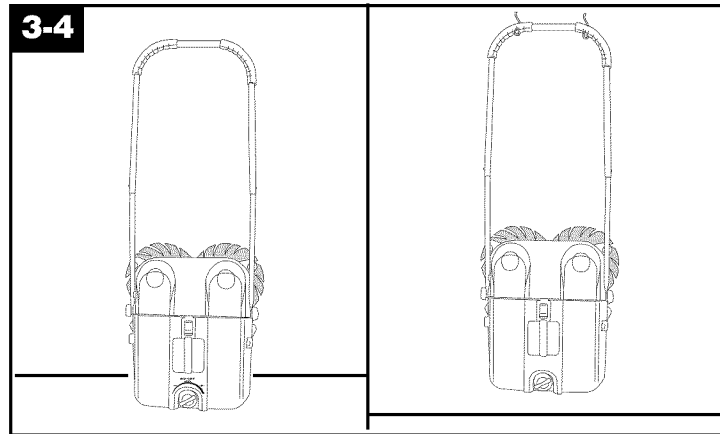

4. If you have a problem

Problem: Debris is swept back onto surface during use.

Possible cause

Possible solution

- **Light debris has collected in front of dirt bin.**
- *Tip the outdoor sweeper back to allow debris to move to back of dirt bin.*

Problem: Line of debris is left while using.

Possible cause

Possible solution

- **Fine debris or large amounts of debris have been picked up.**
- *Overlap the sweeping path to more effectively clean the area.*
- **Sweeper is being pushed too slowly.**
- *Push sweeper slightly faster.*

Problem: Sweeper difficult to push.

Possible cause

Possible solution

- **Surface is rough or uneven.**
- *Turn the height adjustment knob toward a higher setting.*

Problem: Sweeper does not pick up debris.

Possible cause

Possible solution

- **Height adjustment setting set too high for small debris.**
- *Turn the height adjustment knob toward a lower setting.*
- **Height adjustment setting set too low for large debris.**
- *Turn the height adjustment knob toward a higher setting.*

Problem: Brushes won't turn.

Possible cause

Possible solution

- **Surface is uneven.**
- *Turn the height adjustment knob toward a higher setting.*
- **Surface is too smooth.**
- *Sweeper not designed for optimum performance on low friction surfaces, such as vinyl decks.*

Service

To obtain approved HOOVER service and genuine HOOVER parts, locate the nearest **Hoover Factory Service Center or Authorized Hoover Warranty Service Dealer (Depot)** by:

- checking the Yellow pages under "Vacuum Cleaners - Household" OR -
- checking the list of Factory Service Centers provided with this sweeper OR -
- checking the Service section of The Hoover Company on-line at **www.hoover.com** OR -
- calling 1-800-944-9200 for an automated referral of authorized service outlet locations (U.S. only).

Do not send your sweeper to The Hoover Company in North Canton for service, as this will only result in delay.

If further assistance is needed, contact The Hoover Company Consumer Response Center, North Canton, Ohio 44720, Phone: 330-499-9499.

In Canada, contact Hoover Canada, Burlington, Ontario L7R 4A8, Phone: 1-800-263-6376.

Always identify your sweeper by the **complete** model number when requesting information or ordering parts. (The model number appears on the bottom of the sweeper.)

Full One Year Warranty

Your HOOVER® sweeper is warranted in normal household and light commercial use, in accordance with the Owner's Manual against original defects in material and workmanship for a period of one full year from date of purchase. This warranty provides, at no cost to you, all labor and parts to place this sweeper in correct operating condition during the warranted period. This warranty applies when the sweeper is purchased in the United States, including its territories and possessions, or in Canada or from a U.S. Military Exchange. Sweepers purchased elsewhere are covered by a limited one year warranty which covers the cost of parts only. This warranty does not apply if the sweeper is used in a heavy commercial or rental application.

Warranty service can only be obtained by presenting the sweeper to one of the following authorized warranty service outlets. Proof of purchase will be required before service is rendered.

1. Hoover Factory Service Centers
2. Hoover Authorized Warranty Service Dealers (Depots)

For an automated referral of authorized service outlets in the U.S.A., phone 1-800-944-9200 OR visit The Hoover Company on-line at www.hoover.com.

This warranty does not cover pick up, delivery, or house calls; however, if you mail your sweeper to a Hoover Factory Service Center for warranty service, transportation will be paid one way.

While this warranty gives you specific legal rights, you may also have other rights which vary from state to state.

If further assistance is needed, or if there are questions concerning this warranty or the availability of warranty service outlets, write or phone the Consumer Response Center, The Hoover Company, 101 East Maple St., North Canton, Ohio 44720. Phone: 1-330-499-9499

In Canada, contact Hoover Canada, Burlington, Ontario L7R 4A8, 1-800-263-6376.