

Downflow, Direct Vent (Sealed Combustion) Forced Air Gas & Oil Furnaces

Installation Instructions

Series M1B, M1G, M1M & M5S

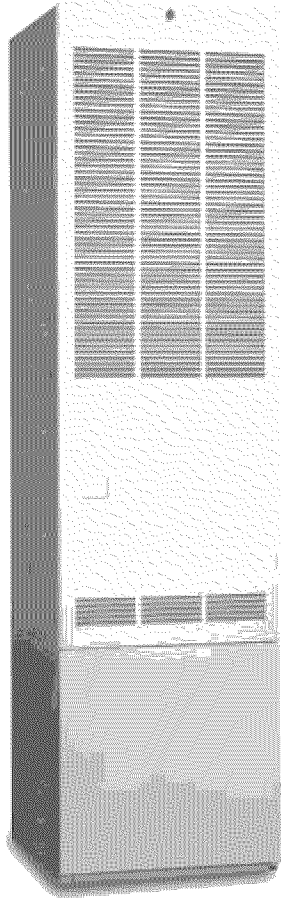

For installation in:

- Manufactured Homes
- Recreational Vehicles, Park Models, & Manufactured Buildings
- Modular Homes/Buildings

ATTENTION INSTALLERS:

It is your responsibility to know this product better than your customer. This includes being able to install the product according to strict safety guidelines and instructing the customer on how to operate and maintain the equipment for the life of the product. Safety should always be the deciding factor when installing this product and using common sense plays an important role as well. Pay attention to all safety warnings and any other special notes highlighted in the manual. Improper installation of the furnace or failure to follow safety warnings could result in serious injury, death, or property damage.

These instructions are primarily intended to assist qualified individuals experienced in the proper installation of this appliance. Some local codes require licensed installation/service personnel for this type of equipment. Please read all instructions carefully before starting the installation. Return these instructions to the customer's package for future reference.

! WARNING:

WHAT TO DO IF YOU SMELL GAS

- Do not try to light any appliance.
- Do not touch any electrical switch; do not use any phone in your building.
- Leave the building immediately.
- Immediately call your gas supplier from a neighbors phone. Follow the gas suppliers instructions.
- If you cannot reach your gas supplier, call the fire department

FIRE OR EXPLOSION HAZARD

- Failure to follow safety warnings exactly could result in serious injury or property damage.
- Installation and service must be performed by a qualified installer, service agency or the gas supplier.
- Do not store or use gasoline or other flammable vapors and liquids in the vicinity of this or any other appliance.

DO NOT DESTROY. PLEASE READ CAREFULLY AND KEEP IN A SAFE PLACE FOR FUTURE REFERENCE.

SAFETY INFORMATION	3	Operating Instructions - Oil Gun	22
REQUIREMENTS & CODES	3	Operating Instructions - Gas Gun.....	22
GENERAL INFORMATION	5	How to Shut Off Gas - Gas Gun	22
Warranty Information	5	Burner Adjustments.....	22
Minimum Clearances	5	Gas Pressure	22
Applications	6	Pilot Flame	22
Unit Location	6	Combustion Air	23
CIRCULATING AIR REQUIREMENTS	7	Gas Gun	23
Return Air Connections	7	Oil Gun	23
Supply Air Connections	7	Electrode Setting - Oil Gun.....	23
FURNACE INSTALLATION	8	Switching Honeywell (R7184) Ignition from	23
General Information.....	8	Interrupted to Intermittent.....	23
Requirements & Codes	8	OPERATING SEQUENCE	24
Locating & Cutting Duct Openings	8	Standing Pilot	24
Standard Duct Connector Installation.....	9	Standing Pilot w/ Induced Draft Blower ...	24
Alternate Attachment Method	10	M1 Models - Direct Ignition.....	24
Round Duct Connector Installation.....	10	Oil Gun Models.....	24
Installing the Furnace	10	Gas Gun Models.....	24
ROOF JACK INSTALLATION	11	FURNACE CONTROLS & FUNCTIONS	25
Roof Jack Selection	11	Furnace On-Off Switch.....	25
Application Notes.....	11	Limit Control	25
Locating & Cutting Roof Openings	12	Gas Valve.....	25
Installing the Roof Jack.....	13	Roll Out Switch - M1G	25
Installation of Transit-Mode Vent System.	13	Oil Burner Primary Control	25
Manufactured Home Factory.....	13	Summer Cooling - B,C,D Series	25
ELECTRICAL INFORMATION.....	14	TROUBLESHOOTING	26
Line Voltage Wiring	14	Standing Pilot Models.....	26
Connecting Power Supply Wires.....	15	Direct Ignition Models	26
Low Voltage Wiring	15	Oil Gun Models.....	27
Connecting Thermostat Wires.....	15	OPTIONAL ACCESSORIES.....	28
Verifying Anticipator Setting.....	15	MAINTENANCE	30
Grounding.....	15	Homeowner Information	30
FUEL SUPPLY AND PIPING	16	Installer Information Information	30
Oil Tank & Piping Installation	17	FIGURE & TABLES.....	31
One Line System	17	Table 10 - Furnace Specifications	31
Two Line System.....	17	Table 11 - Orifice Sizes - High Alt.....	32
Fuel Line Hook Up	17	Table 12 - Blower Speed Selection.....	32
Leak Check	18	Gas Information	33
Priming Honeywell R7184	18	Table 13 - Gas Flow Rates	33
Priming Beckett 7505	18	Table 14 - Gas Pipe Capacities	33
Fuel Oil Type	18	Wiring Diagrams	34
Conversion to Propane Gas	18	Fig. 39 - Gas Furnace - 056, 070	34
Atmospheric & Direct Ignition	18	Fig. 41 - Standing Pilot - 077, 090	35
High Altitude Conversion	19	Fig. 42 - Gas Furn. w/ac 056, 070	36
Flue Gas Sampling	19	Fig. 43 - Standing Pilot. w/ac 077, 090	37
STARTUP & ADJUSTMENTS	20	Fig. 44 - Gas Only (M1M Models)	38
Lighting Instructions - Pilot Models.....	20	Fig. 45 - Gas & Oil (M1B & M5S)	39
How to Shut Off Gas - Pilot Models.....	21	Installation Checklist.....	40
Operating Instructions - Direct Ignition ...	21		
How to Shut Off Gas - Direct Ignition ...	22		

SAFETY INFORMATION

Safety markings are used frequently throughout this manual to designate a degree or level of seriousness and should not be ignored. **WARNING** indicates a potentially hazardous situation that if not avoided, could result in personal injury or death. **CAUTION** indicates a potentially hazardous situation that if not avoided, may result in minor or moderate injury or property damage.

WARNING:

The safety information listed below must be followed during the installation, service, and operation of this furnace. Failure to follow safety recommendations could result in possible damage to the equipment, serious personal injury or death.

- Use only with type of gas approved for this furnace. Refer to the furnace rating plate.
- Install this furnace in accordance to the minimum clearances to combustible materials listed in Table 1 (page 5).
- Provide adequate combustion air to the furnace space as specified on page 23.
- Combustion products must be discharged outdoors. Connect this furnace to an approved vent system, as specified on pages 13 - 14.
- Never test for gas leaks with an open flame. Use a commercially available soap solution to check all connections (page 18).
- This furnace is designed to operate with a maximum external pressure rise of 0.5 inches of water column. Consult Table 8 (page 38), and the rating plate for the proper circulating air flow and temperature rise.
NOTE: It is important that the duct system be designed to handle the desired flow rate and external pressure rise. An improperly designed duct system can result in nuisance shutdowns, and comfort or noise issues.
- This furnace may not be used for temporary heating of buildings or structures under construction.
- When supply ducts carry air circulated by the furnace to areas outside the space containing the furnace, the return air shall also be handled by duct(s) sealed to the furnace casing and terminating outside the space containing the furnace. See page 14.

WARNING:

Do not use this appliance if any part has been submerged under water. Immediately call a qualified service technician to inspect the appliance and to replace any part of the control system and any gas control that has been submerged underwater.

Notice to Installer

Installer is advised to carefully follow all instructions and warnings in this manual to insure maximum performance, safety, and operating efficiency of these appliances. Improper installation may create hazardous conditions, and will void the appliance warranty.

WARNING:

**PROPOSITION 65 WARNING:
This product contains chemicals known to the state of California to cause cancer, birth defects or other reproductive harm.**

REQUIREMENTS AND CODES

This furnace must be installed in accordance with these instructions, all applicable local building codes and the current revision of the National Fuel Gas Code (NFPA54/ANSI Z223.1) or the Natural Gas and Propane Installation Code, CAN/CGA B149.1.

CE générateur d'air chaud doit être installé conformément aux instructions du fabricant et aux codes locaux. En l'absence de code local, respecter la norme ANSI Z223.1, intitulé National Fuel Gas Code ou les codes d'installation CAN/GCA-B149.

The Commonwealth of Massachusetts requires compliance with regulation 248 CMR 4.00 and 5.00 for installation of through – the – wall vented gas appliances as follows:

1. For direct-vent appliances, mechanical-vent heating appliances or domestic hot water equipment, where the bottom of the vent terminal and the air intake is installed below four feet above grade the following requirements must be satisfied:

- a.) A carbon monoxide (CO) detector and alarm shall be placed on each floor level where there are bedrooms. The detector shall comply with NFPA 720 (2005 Edition) and be mounted in the living area outside the bedroom(s).
 - b.) A (CO) detector shall be located in the room that houses the appliance or equipment and shall:
 - Be powered by the same electrical circuit as the appliance or equipment. Only one service switch shall power the appliance and the (CO) detector;
 - Have battery back-up power;
 - Meet ANSI/UL 2034 Standards and comply with NFPA 720 (2005 Edition); and Approved and listed by a Nationally Recognized Testing Laboratory as recognized under 527 CMR.
 - c.) A Product-approved vent terminal must be used, and if applicable, a product-approved air intake must be used. Installation shall be in strict compliance with the manufacturer's instructions. A copy of the installation instructions shall remain with the appliance or equipment at the completion of the installation.
 - d.) A metal or plastic identification plate shall be mounted at the exterior of the building, 4 feet directly above the location of vent terminal. The plate shall be of sufficient size, easily read from a distance of eight feet away, and read "Gas Vent Directly Below".
2. For direct-vent appliances, mechanical vent heating appliances or domestic hot water equipment where the bottom of the vent terminal and the air intake is installed above four feet above grade the following requirements must be satisfied:
- a.) A (CO) detector and alarm shall be placed on each floor level where there are bedrooms. The detector shall comply with NFPA 720 (2005 Edition) and be mounted in the living area outside the bedroom(s).
 - b.) The (CO) detector shall:
 - Be located in the room that houses the appliance or equipment;
 - Be hard-wired, battery powered or both.
 - Shall comply with NFPA 720 (2005 Edition).
 - c.) A product-approved vent terminal must be used, and if applicable, a product-approved air intake must be used. Installation shall be in strict compliance with the manufacturer's instructions. A

copy of the installation instructions shall remain with the appliance or equipment at the completion of the installation.

The information listed below is for reference purposes only and does not necessarily have jurisdiction over local or state codes. Always consult with local authorities before installing any gas appliance.

Combustion and Ventilation Air

- US: National Fuel Gas Code (NFGC), Air for Combustion and Ventilation
- CANADA: Natural Gas and Propane Installation Codes (NSCNGPIC), Venting Systems and Air Supply for Appliances

Duct Systems

- US and CANADA: Air Conditioning Contractors Association (ACCA) Manual D, Sheet Metal and Air Conditioning Contractors National Association (SMACNA), or American Society of Heating, Refrigeration, and Air Conditioning Engineers (ASHRAE) Fundamentals Handbook

Electrical Connections

- US: National Electrical Code (NEC) ANSI/NFPA 70
- CANADA: Canadian Electrical Code CSA C22.1

Gas Piping and Gas Pipe Pressure Testing

- US: NFGC and National Plumbing Codes
- CANADA: NSCNGPIC

General Installation

- US: Current edition of the NFGC and the NFPA 90B. For copies, contact the National Fire Protection Association Inc., Batterymarch Park, Quincy, MA 02269; or American Gas Association, 400 N. Capitol, N.W., Washington DC 20001 or www.NFPA.org
- CANADA: NSCNGPIC. For a copy, contact Standard Sales, CSA International, 178 Rexdale Boulevard, Etobicoke (Toronto), Ontario, M9W 1R3 Canada

Safety

- US: (NFGC) NFPA 54–1999/ANSI Z223.1 and the Installation Standards, Warm Air Heating and Air Conditioning Systems ANSI/NFPA 90B.
- Federal Manufactured Home Constructions & Safety Standard (H.U.D. Title 24, Part 3280.707[a][2])
- The Standard for Manufactured Home Installations (Manufactured Home Sites, Communities, and Set-Ups) ANSI A225.1 and/or CAN/CSA-2240 MH Series).

- American National Standard (ANSI-119.2/ NFPA-501C) for all recreational vehicle installations.
- CANADA: CAN/CGA-B149.1 and .2-M00 National Standard of Canada. (NSCNGPIC)

GENERAL INFORMATION

Manufacturer Warranty - Owner's Responsibilities

It is the sole responsibility of the homeowner to make certain the gas furnace has been correctly set up and converted to the proper fuel (L.P. gas or Natural gas) and adjusted to operate properly. All gas furnaces are manufactured for Natural gas and must be field converted when using L.P. gas.

⚠ CAUTION:

- **Do Not alter or modify this furnace or any of its components.**
- **Never attempt to repair damaged or inoperable components. This may cause unsafe operation, explosion, fire and/or asphyxiation.**
- **If furnace malfunctions or does not operate properly, contact a qualified service agency or gas utility for assistance.**

A warranty certificate with full details is included with these instructions. However, NORDYNE will not be responsible for any costs found necessary to correct problems due to improper setup, improper installation, furnace adjustments, improper operating procedure on the part of the user, etc. Carefully review these responsibilities with your manufactured housing dealer, service company or gas supplier. Some specific examples of service calls which cannot be included in warranty payments are:

- Converting the furnace to use another type of gas.
- Repairing duct work in the home found to be faulty.
- Correcting wiring problems in the electrical circuit supplying the furnace.
- Resetting circuit breakers, blown fuses or other switches.
- Correcting problems due to improper gas supply pressure to the furnace.
- Providing instructional training on how to light and operate the furnace.
- Furnace problems caused by installation of an air conditioner, heat pump or other air comfort devices.

- Adding a Roof Jack extension because of unusual wind and/or snow conditions.
- Revising installation of the furnace flue assembly (Roof Jack).
- Adjusting or calibrating of thermostat.
- Any construction debris which falls into flue system.

Minimum Clearances

This heating appliance must be installed with clearances not less than the minimums listed in Table 1. This furnace must be installed with ample clearance for easy access to the air filter, blower assembly, burner assembly, controls, and vent connections. See Figures 1 - 3 (page 6).

- The dimensions of the room or alcove must be able to accommodate the overall size of the furnace and the installation clearances listed in Table 1 and in Figure 4 (page 6).
- Alcove installations: minimum 18" clearance at front of furnace shall be provided for future servicing. A removable access panel should be installed between top of the furnace door frame and the ceiling.
- Closet installations must use a louvered door having a minimum free area of 235 sq. in. when located 6" from furnace or 390 sq. in. for 5 ton ready M1/M5 furnaces. For special clearance between 1" and 6", requirements are a louvered door with a minimum of 250 sq. in. free area, with the openings in the closet door in line with the louvered openings in the furnace door. A fully louvered closet door may be used. See Circulating Air Requirements (page 7).

ALL MODELS	CLOSET	ALCOVE
Front	6"	18"
Back	0"	0"
Sides	0"	0"
Roof Jack	0"	0"
Top	6"	6"
Top and Sides of Duct	0"	0"
Bottom of Duct		
B Cabinet	0"	0"
A Cabinet (w/ coil box)	0"	0"
A Cabinet (w/o coil box)	1/4"	1/4"

Table 1. Minimum Clearances

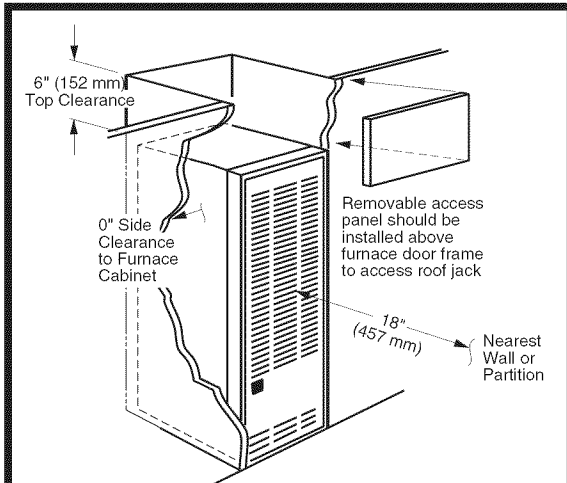

Figure 1. Alcove Installation

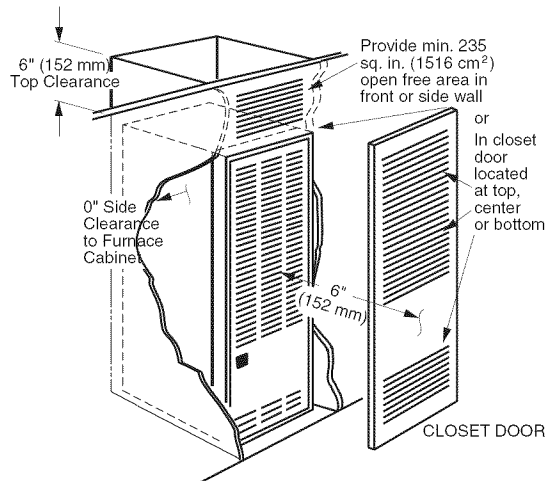

Figure 2. Closet Installation

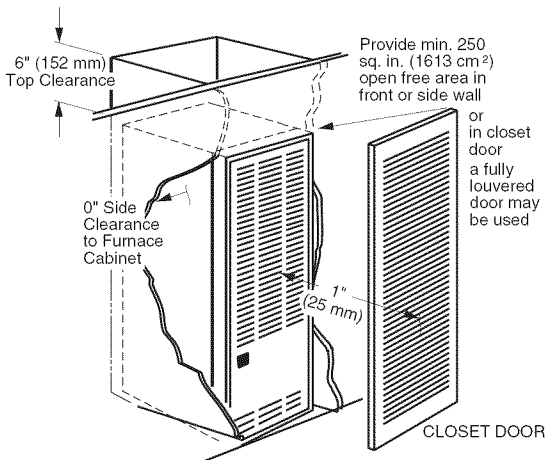

Figure 3. Special 1" Clearance

Part No.	Blower / Motor Assembly		A/C Capacity (Tons)
	Blower Wheel	Motor (Hp)	
903773	10 x 8	1/4	2, 2½ & 3
903413	11 x 8	1/2	2, 2½, 3 & 4
903890	11 x 8	3/4	2, 2½, 3, 4 & 5

Table 2. Blower Assemblies

Applications

M1 Series gas and M5 Series oil furnaces are listed direct vent (sealed combustion), downflow heating appliances for manufactured (mobile) homes, recreational vehicles, and for use in residential/modular/commercial construction. The furnace must be located so that venting can be properly achieved.

Air conditioning may be added to structures with M1/M5 series furnaces using air conditioning or conventional units. This Installation Instruction manual includes special requirements for incorporation of air conditioning equipment to the M1/M5 series of furnaces. See Tabel 12 (page 32).

Multi-speed blower assemblies shown in Table 2, have been certified for field installation in M1/M5 Series furnaces.

Unit Location

- The furnace shall be appropriately located to the supply and return air distribution system (See Page 7). Sides and back of the furnace may be enclosed by wall framing. See Minimum Clearances (page 2) and Figures 1- 3.
- The furnace installation is only intended for free air return through the furnace door louvers. **DO NOT** connect a ducted return air system directly to the furnace. Improper installation may create a hazard and damage equipment, as well as void all warranties.
- Furnace may be installed on combustible flooring when using NORDYNE Duct Connectors. See pages 9 & 10.
- When installed in a residential garage, the furnace must be positioned so the burners and the source of the ignition are located no less than 18 inches above the floor and protected from physical damage by vehicles.

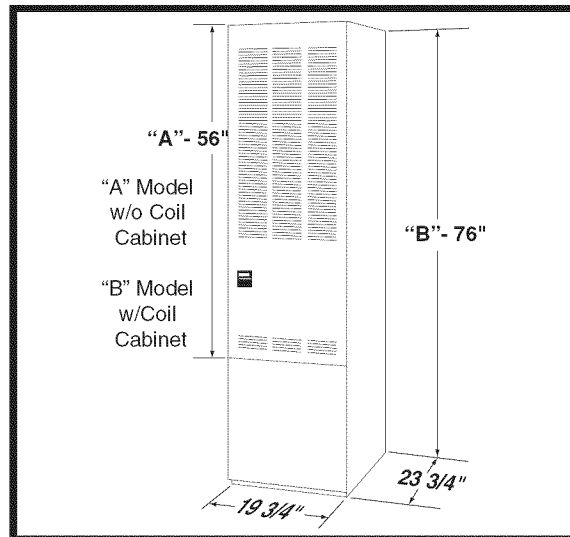

Figure 4. Overall Dimensions

 **WARNING:**

Do not allow combustion products to enter the circulating air supply. Failure to prevent the circulation of combustion products into the living space can create potentially hazardous conditions including carbon monoxide poisoning that could result in personal injury or death.

All return ductwork must be secured to the furnace with sheet metal screws. For installations in confined spaces, all return ductwork must be adequately sealed. The joint between the furnace and the return air plenum must be air tight.

The surface that the furnace is mounted on must provide sound physical support of the furnace with no gaps, cracks or sagging between the furnace and the floor or platform.

Return air and circulating air ductwork must not be connected to any other heat producing device such as a fireplace insert, stove, etc. This may result in fire, explosion, carbon monoxide poisoning, personal injury, or property damage.

Return Air Connections

U.S.A. home manufacturers shall comply with all of the following conditions to have acceptable return air systems for closet installed forced air heating appliances:

- The return air opening into the closet shall not be less than specified in the appliance's listing.
- The cross-sectional area of the return duct system leading into the closet, when located in the floor or ceiling shall not be less than 235 square inches (or 390 square inches for 5 ton ready M1/M5 Furnaces).

 **CAUTION:**

HAZARD OF ASPHYXIATION: Do not cover or restrict return air opening.

- Means shall be provided that prevent inadvertent closure of flat objects placed over the return air opening located in the floor of the closet (versus the vertical front or side wall).
 - The total free area of openings in the floor or ceiling registers serving the return air duct system must be at least 235 sq. in. At least one register should be located where it is not likely to be covered by carpeting, boxes and other objects.
 - Materials located in the return duct system must have a flame spread classification of 200 or less. This includes a closet door if the furnace is in a closet.
 - Noncombustible pans having 1" upturned flanges are located beneath openings in a floor duct system.
 - Wiring materials located in the return duct system shall conform to Articles 300-22 of the National Electrical Code (ANSI C1/NFPA-70).
 - Gas piping is not run in or through the return duct system.
-

 **CAUTION:**

HAZARD OF ASPHYXIATION: Negative pressure inside the closet, with closet door closed and the furnace blower operating on high speed, shall be no more negative than minus 0.05 inch water column.

- Test the negative pressure in the closet with the air-circulating fan operating at high speed and the closet closed. The negative pressure is to be no more negative than minus 0.05 inch water column.
- Air conditioning systems may require more duct register and open louver area to obtain necessary airflow. Use NORDYNE's certiduct program to determine proper duct size for A/C.

Supply Air Connections

For proper air distribution, the supply duct system must be designed so that the static pressure measured external to the furnace does not exceed the listed static pressure rating shown on the furnace rating plate.

Location, size, and number of registers should be selected on the basis of best air distribution and floor plan of the home. **The supply air must be delivered to the heated space by duct(s) secured to the furnace casing, running full size and without interruption.**

Three typical distribution systems are shown in Figure 5. The location, size, and number of registers should be selected on the basis of best air distribution and floor plan of the home.

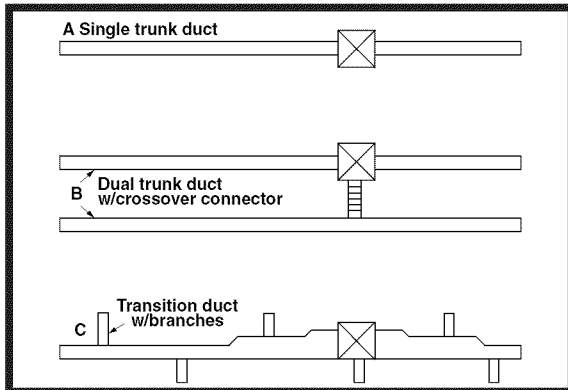

Figure 5. Typical Supply Duct System

FURNACE INSTALLATION

NOTE: These Installation procedures are suggested for typical furnace installations. Since all installations are different from each other, the sequence of instructions may differ from the actual installation. Only qualified HVAC technicians should install this furnace.

General Information

- The furnace must be leveled at installation and attached to a properly installed duct system. **Do not use the back of the furnace for return air.** See page 7 for circulating requirements.
- The furnace must be installed so that all electrical components are protected from water.
- The dimensions of the room or alcove must be able to accommodate the overall size of the furnace and the installation clearances listed in Table 1 and Figure 3 (page 6)
- The furnace must be installed upstream from a refrigeration system.
- The plenum attached to the A/C coil box and ductwork within 3 ft. of the furnace must be installed so that surfaces are at least 1/4" from combustible construction.
- The cabinet plug must always be used to close the hole in the side of the furnace when rotating the inducer.
- M1/M5 models must be installed with the Nordyne A/C coil box which are listed according to the cabinet size of the furnace: "B" cabinet - 920169, "C" cabinet - 920171, and "D" cabinet - 920172.

- The M1 Series gas and M5 Series oil furnace is certified for use on wood flooring or supports, but must be installed on top of a duct connector. This factory supplied accessory must be installed in the floor cavity and attached to the supply air duct before the furnace is installed.

Requirements and Codes

Installer must be familiar with and comply with all codes and regulations applicable to the installation of these heating appliances and related equipment. In the absence of local codes, the installation must be in accordance with the current provisions of one or more of the following standards.

- Federal Manufactured Home Construction & Safety Standard (H.U.D. Title 24, Part 3280.707[a][2])
- American National Standard (ANSI-119.2/NFPA-501C) for all recreational vehicle installations.
- American National Standard (ANSI-Z223.1/NFPA-54) and/or CAN/CSA B149 for all gas-fired furnace models.
- American National Standard (ANSI-Z95.1/NFPA-31) and/or CSA B139 for all oil-fired furnace models.
- American National Standard (ANSI-C1/NFPA-70) and/or CSA 22.1 Canadian Electric Code Part 1 for all electrical field wiring.
- Units have been researched under standards UL 307A & B, UL727-1999, ANSI Z21.47b/CSA 2.3b-2008, and CSA B140.10.

Locating and Cutting Duct Openings

Floor cut-outs and fuel line holes must be carefully located to avoid misalignment of the furnace, and vent piping. To locate standard ducts see Figure 6 (page 9). For round ducts, see Figure 7.

1. Measure 10" from the rear wall or alcove and mark the centerline of the cut-out on the floor.
2. Using the centerline as a starting point, draw the rest of the duct cut-out to the dimensions shown in Figures 6 or 7.
3. Cut out the floor opening 1/16" larger than the actual cutout drawn. This will allow some clearance when installing the duct connector.
4. Measure from the top of the floor down to the top of the supply air duct to obtain the depth of the floor cavity. **NOTE:** The depth of the floor cavity shown as "X" in Figure 9 (page 9) will determine the correct duct connector.
5. Determine which duct connector to use from Table 3 (page 9).
6. Measure and drill gas hole. and cut out for cooling coil (if applicable). See Figures 6 or 7 (page 9).

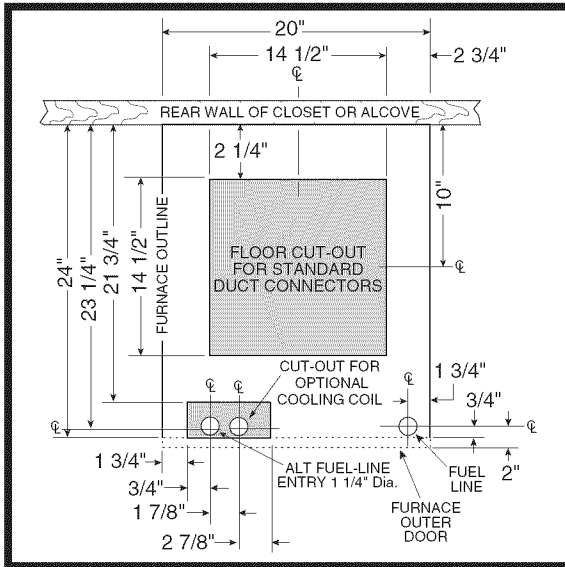

Figure 6. Cut-Out Dimensions for Standard Duct Connectors

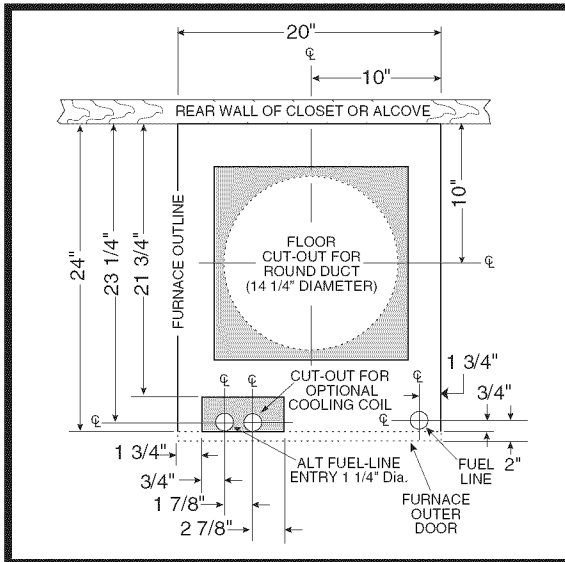

Figure 7. Cut-Out Dimensions for Round Duct Connectors

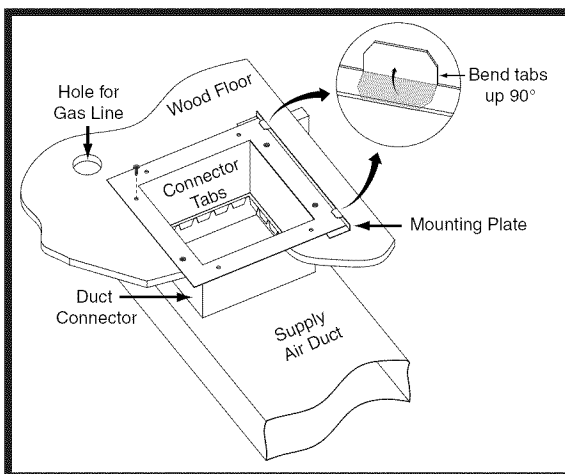

Figure 8. Standard Duct Connector Installed

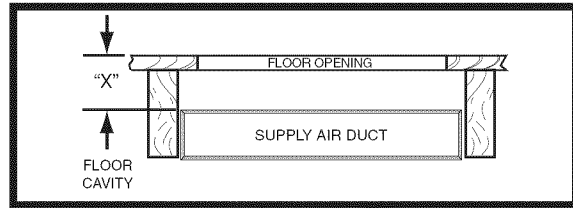

Figure 9. Floor Cavity

If Floor Cavity "X" is:	Duct Connector Type & Part Number	
	Standard Duct	Round Duct
7/8" / (22)	901987A	904008
2" / (51)	901988A	904009
4-1/4" / (108)	901989A	904010
6-1/4" / (159)	901990A	904011
8-1/4" / (210)	901991A	904012
10-1/4" / (260)	901992A	904013
12-1/4" / (311)	901993A	904014

Note: Dimensions shown as Inches / (Millimeter)

Table 3. Duct Connector Sizes

Standard Duct Connector Installation

The standard duct connector is designed for use on ducts 12" in width. However ducts narrower than 12" may not allow sufficient clearances for this type of installation. For an alternate installation method, see page 10.

1. Center the duct connector in the floor opening with bottom tabs resting on top of the supply air duct.
2. Mark the cut-out area on the supply air duct by tracing around the connector tabs (Figure 8) of the duct connector.
3. Remove the duct connector and cut out the marked area of the supply air duct 1/4" larger the actual cutout drawn.
4. Install the duct connector back in the floor opening with the bottom tabs extending into the supply air duct.
5. Install the mounting plate (Figure 8) under the back side of the duct connector. Align the screw holes in both components.
6. Secure the duct connector and the mounting plate to the wood floor with appropriate size screws.
7. Bend the connector tabs on the bottom of the duct connector upwards and as tight as possible against the supply air duct.
8. Bend both tabs on the mounting plate up 90°. See Figure 10, (page 10)
9. Seal all connections with industrial grade sealing tape or liquid sealant.

NOTE: Requirements for sealing ductwork vary from region to region. Consult with local codes for requirements specific to your area.

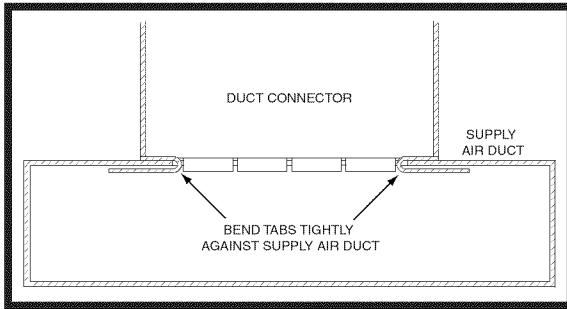

Figure 10. Duct Connector Tabs

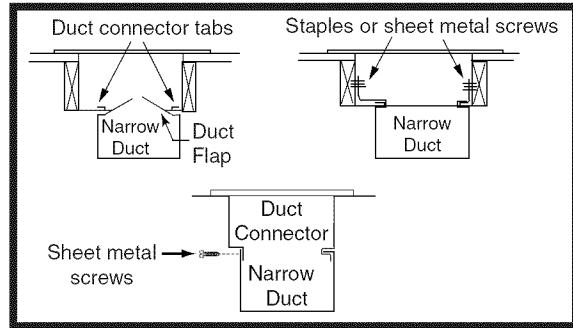

Figure 12. Narrow Ducts

Alternate Attachment Method

The standard duct connector is designed for use on ducts 12" in width. However if there is insufficient clearance to bend the duct connector tabs, this alternate attachment method may be used.

1. Score and cut the top of the supply air duct as indicated in Option 1 or Option 2 (Figure 11). With Option 1 choice, cut out the metal from the shaded area.
2. Fold the two flaps (Options 1 or 2) up to form the opening for the duct connector.
3. Install the duct connector with the bottom tabs extending into the supply air duct.
4. Bend the tabs on the bottom of the duct connector upwards and as tight as possible against the supply air duct (Figure 12).
5. Form the flaps (Options 1 or 2) up against the duct connector as tight as possible.
6. Secure the duct connector flaps to the supply air duct with staples (3 minimum) or if a 2x block/joist is not provided, use sheet metal screws (2 minimum). **NOTE:** The duct connector tabs may be attached to the air duct with sheet metal screws or other suitable fasteners as long as the duct connector and the air duct are securely attached.
7. Seal all connections with industrial grade sealing tape or liquid sealant.

NOTE: Requirements for sealing ductwork vary from region to region. Consult with local codes for requirements specific to your area.

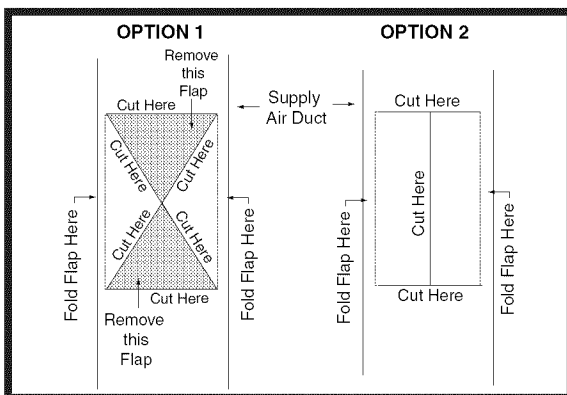

Figure 11. Narrow Air Duct Openings

Round Duct Connector Installation

1. Apply a bead of caulking, mastic, or other approved sealant around bottom side of connector.
2. Install and center the duct connector in the floor opening.
3. Install the mounting plate under the back side of the duct connector. See Figure 13 (page 11). **NOTE:** Align the screw holes in both components.
4. Secure the duct connector and the mounting plate to the wood floor with appropriate size screws.
5. Connect the round supply duct to the underside of the duct connector and secure them with field supplied sheet metal screws.
6. Seal all connections with industrial grade sealing tape or liquid sealant.

NOTE: Requirements for sealing ductwork vary from region to region. Consult with local codes for requirements specific to your area.

Installing The Furnace

Sides and back of the furnace may be enclosed by wall framing such as in a closet or alcove. The dimensions of the room or alcove must be able to accommodate the overall size of the furnace and the installation clearances outlined on page 2 and Figures 1 - 4 (page 6). The furnace shall be appropriately connected to the supply and return air distribution system as shown in Figures 14 & 15 (page 11).

1. Remove furnace outer door(s) and bottom fuel line knockout.
2. Place furnace onto duct connector and center with floor opening.
3. Slide onto mounting plate. (Bottom rear slots on furnace should engage with mounting plate tabs.)
4. Secure front with one (1) fastener at each corner (Figures 14 or 15).

NOTE: Additional fasteners may be used at rear, sides or through door frame, as desired, to secure furnace to closet or alcove framing.

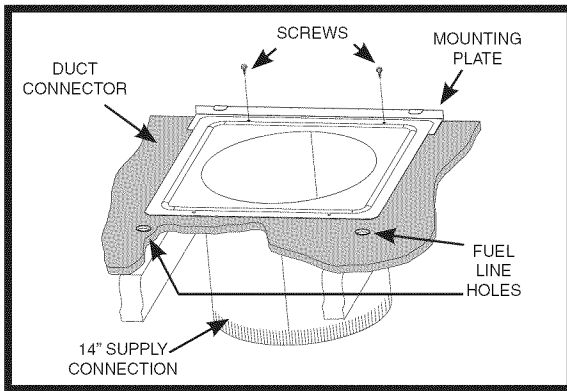

Figure 13. Round Duct Connector Installed

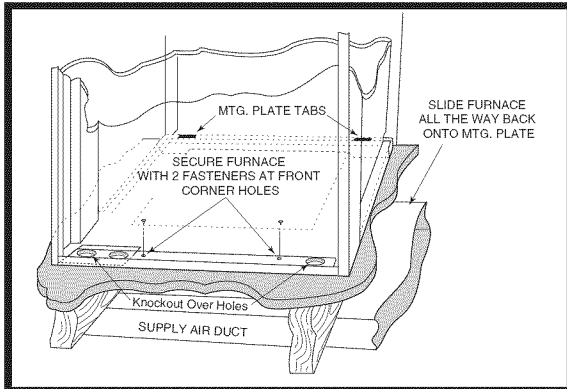

Figure 14. "A" & "B" Cabinet Furnaces

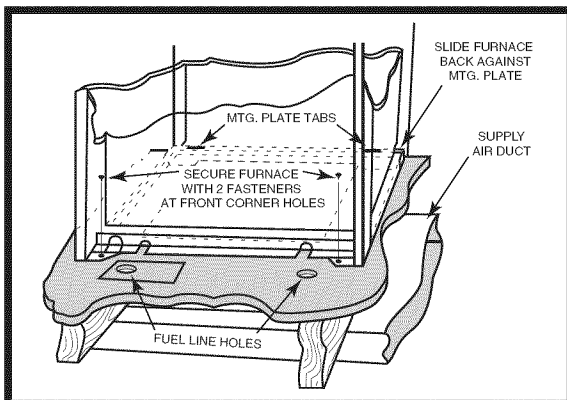

Figure 15. "A" Cabinet Furnace on Coil Cabinet

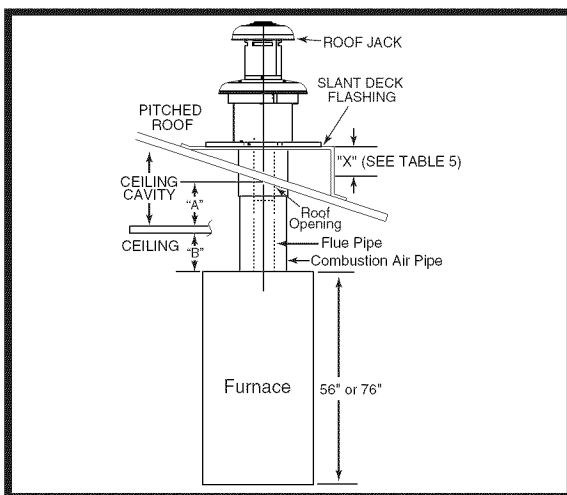

Figure 16. Ceiling Cavity Depth

ROOF JACK INSTALLATION

Required ceiling and roof cut-out openings (see Figure 11) must be carefully located to avoid misalignment of the furnace and Roof Jack. **Note:** Install only Roof Jack Assemblies listed in Table 4 on this heating appliance.

Roof Jack Selection

1. Determine depth of ceiling cavity from center of roof opening to center of ceiling opening. (See Dimension "A" in Figure 16.)
2. Determine ceiling height and subtract height of furnace. (See Dimension "B" in Figure 16.)
3. Add dimensions A + B (and X from Table 5 and Figure 18 if slant deck flashing is used). The total length of (A + B + X) must be within the minimum and maximum range of one of the Roof Jacks listed in Table 4.

Application Notes:

- FAW, FAWT, SAW and SAWT Series Roof Jacks with a 5" diameter inner vent pipe may be used with all models of M1 Series gas and M5 Series oil furnaces.

F = Flat Flashing: flexes from 0/12 to 1/12 roof slope. See Figure 17 (page 12).

S = Slant Flashing: 2.5/12 Slope flexes from 1/12 to 4/12 roof slope, 4/12 flexes from 3/12 to 5/12. See Figure 18.

- Stainless steel roof jacks are available.
- M1/M5 furnaces may be used with roof jacks as tall as 170" (except M1M 056 & M1B 066 models, which are limited to 120"). An internal roof jack extension (p/n 901935 - 10", p/n 903107 - 18") can be used to increase roof jack height. All connections inside the home must be made below the ceiling.

NOTE: If the roof jack crown is covered or blocked with snow, the furnace will not operate properly.

MODEL NUMBER	APPROX. LENGTH BELOW FLASHING
(F,S)AW(T)1523-(0,2,4)(A,S)	15" - 23"
(F,S)AW(T)2135-(0,2,4)(A,S)	21" - 35"
(F,S)AW(T)2747-(0,2,4)(A,S)	27" - 47"
(F,S)AW(T)3563-(0,2,4)(A,S)	35" - 63"
(F,S)AW(T)5195-(0,2,4)(A,S)	51" - 95"

F = FLAT FLASHING	S	AW	T	27	47	- 2	S	FLUE STEEL TYPE
S = SLANT FLASHING								A = ALUMINIZED
								S = STAINLESS
		AW = ALL WEATHER						FLASHING PITCH/12" RISE
								0 = FLAT
								2 = 2.5/12
								4 = 4/12
								TYPE:
								BLANK = NON-TRANSIT
								T = TRANSIT MODE
								MIN. ADJ. LENGTH
								MAX. ADJ. LENGTH

Table 4. Roof Jack Assemblies

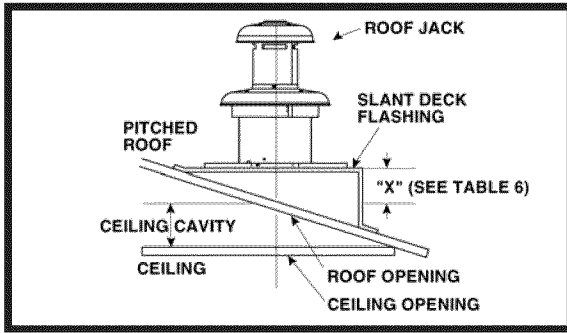

Figure 17. Example of Flat Jack with Flashing

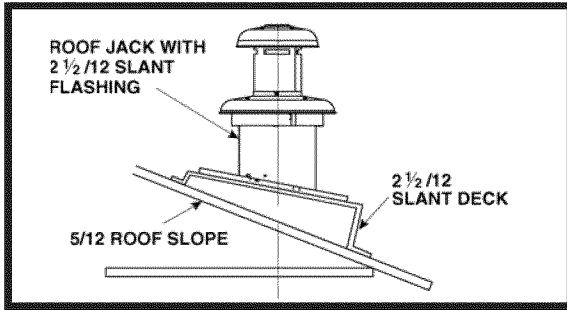

Figure 18. Example of 2 1/2 /12 Slant Jack with Flashing

If the home is located in regions where snow accumulation exceeds 7" (HUD snowload zones) use an external roof jack extension (p/n 901937). Extensions are optional accessories and may be purchased through your NORDYNE distributor.

Locating and Cutting Roof & Ceiling Openings
DO NOT ALLOW DEBRIS TO FALL INTO THE FURNACE. THIS COULD CAUSE UNSAFE OPERATION AND VOIDS THE FURNACE WARRANTY. Use the top cap that comes with the furnace packaging (or alternate protector) to prevent debris from falling into the furnace before the final roof jack connection is made

1. Locate center of Roof Jack opening, measure 13 1/2" from the rear wall of closet or alcove along the center line of furnace and floor opening. See Figure 19.
2. Cut ceiling and roof holes as follows:
 - Ceiling = 8 3/4" (222 mm) diameter
 - Roof = 9 3/8" (238 mm) diameter

! IMPORTANT:

Refer to the installation instructions provided with optional air conditioning packages when installing furnaces with optional cooling coil cabinet or with optional C* series indoor coils.

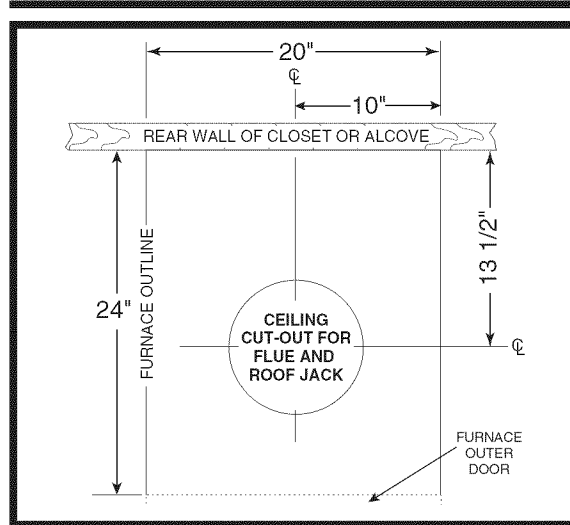

Figure 19. Cut-Out Dimensions for Flue & Roof Jack

ROOF JACK SERIES	IF ROOF PITCH IS:	SLANT DECK FLASHING NUMBER	"X" FACTOR IS:
"F" Series	2" in 12"	903893 (2.5/12)	2-1/8"
	2-1/2" in 12"	903893 (2.5/12)	2-1/2"
	3" in 12"	903894 (3/12)	2-7/8"
	3-1/2" in 12"	903894 (3/12)	3-1/4"
	4" in 12"	903895 (4/12)	3-5/8"
"S" Series (2.5 / 12 Pitch only)	4-1/2" in 12"	903895 (2.5/12)	2-1/8"
	5" in 12"	903895 (2.5/12)	2-1/2"
	5-1/2" in 12"	903894 (3/12)	2-7/8"
	6" in 12"	903894 (3/12)	3-1/4"
	6-1/2" in 12"	903895 (4/12)	3-5/8"

Optional Deck Flashings for Flat and 2.5/12 Pitch Roof Jacks. 4/12 Pitch Roof Jacks not applicable.

Table 5. Slant Deck Flashings

Installing The Roof Jack

1. Apply caulking compound on underside of roof flashing to form a continuous strip at least 3/8" wide around the underside of the perimeter of the flashing. See Figures 20 or 21.
2. Connect Roof Jack Assembly to the furnace. Insert telescoping Roof Jack Assembly through the opening cut on the roof.
3. Connect flue pipe to flue collar of furnace. See Figure 22.
4. Connect combustion air pipe to furnace collar with sheet metal screw (See Figure 22).

NOTE: It is recommended that the connection of the combustion air pipe to the furnace be made before the flashing is secured to the roof to maintain alignment of roof jack and furnace connections.

NOTE: For replacement furnaces, be sure the inner flue pipe connects over the furnace vent collar. **DO NOT use a smaller diameter inner flue pipe which could slide inside the furnace vent collar and restrict the flow of furnace flue products.**

5. Attach Roof Flashing. If necessary, shift roof flashing slightly in the roof opening so that assembly is in alignment with furnace.

NOTE: If flashing is mounted on 12 degree angle, it may be necessary to adjust the angle to match the roof pitch; (1/12 - 4/12 maximum).

6. Press down firmly on roof flashing (over caulking) to make the seal with roof water tight.
7. Secure flashing with appropriate fasteners.

NOTE: For added protection against leaks, coat the flashing plate and fasteners with approved roofing compound.

Installation of Transit-Mode Venting System Manufactured Home Factory

1. Furnace must be installed in accordance to furnace installation manual.
2. Select appropriate Roof Jack from Table 4 (page 11).
3. Roof Jack (less upper Roof Jack crown), with weather cap to be installed as described under Install Roof Jack.

NOTE: Upper Roof Jack crown to be stored in a prominent location inside manufactured home until on-site installation.

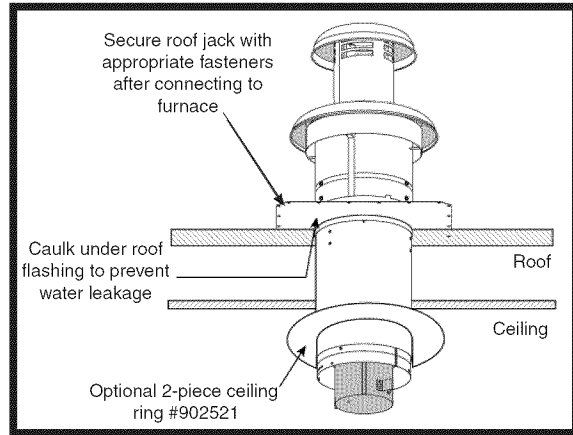

Figure 20. Flat Roof

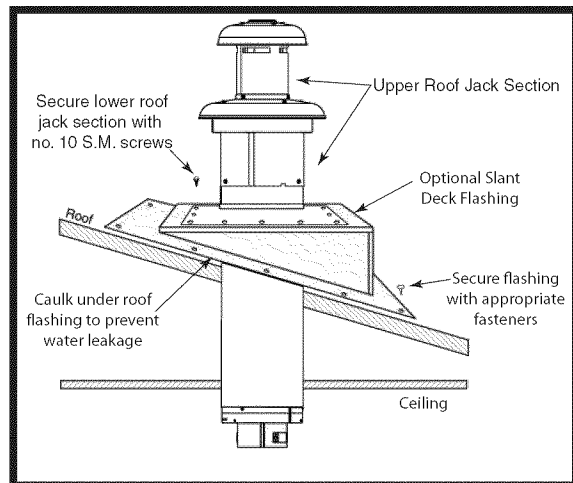

Figure 21. Pitched Roof

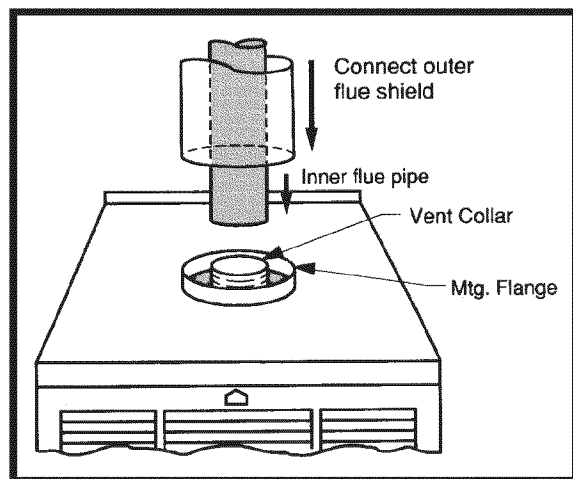

Figure 22. Combustion Air Pipe Connection

4. The four warning tags supplied must be installed as follows:
 - To weather cap
 - To fuel line connection point (Gas) or furnace burner (Oil)
 - To furnace flame observation door (Gas or Oil)
 - To furnace wall thermostat
5. Transit-mode weather cap to be removed and upper Roof Jack crown installed (See Figure 24). Do Not Discard screws.
6. Place upper Roof Jack (crown) on to the flue pipe assembly. **NOTE:** Make sure inside flue pipe attaches over inner flue pipe and outer Roof Jack pipe fits over outer pipe.
7. Secure in place using three (3), #10, 1/2" sheet metal screws removed in step 5. Do not use the same holes which secured the rain cap in place.
8. Remove and discard venting system warning tags.

! WARNING:

Failure to properly secure the flue pipe to the furnace may result in fire, explosion or asphyxiation when operating the furnace.

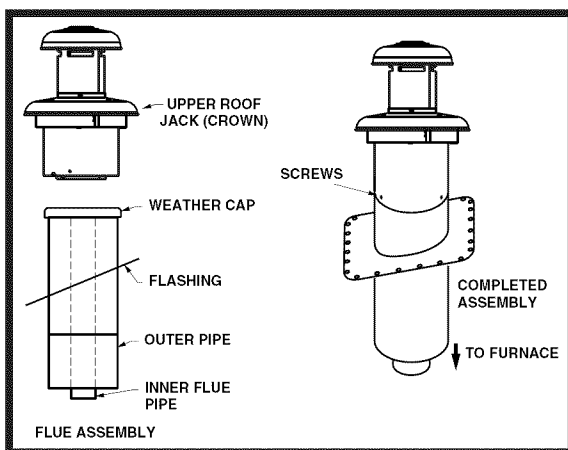

Figure 23. Roof Jack Crown

ELECTRICAL INFORMATION

! WARNING:

To avoid electric shock, personal injury, or death, turn off the electric power at the disconnect or the main service panel before making any electrical connections.

- Electrical connections must be in compliance with all applicable local codes with the current revision of the National Electric Code (ANSI/NFPA 70).
- For Canadian installations the electrical connections and grounding shall comply with the current Canadian Electrical Code (CSA C22.1 and/or local codes).

Line Voltage Wiring

It is recommended that 115VAC line voltage be supplied to the furnace from a dedicated branch circuit containing the correct fuse or circuit breaker for the furnace. See Table 10 (page 31).

IMPORTANT NOTE: An electrical disconnect must be installed readily accessible from and located within sight of the furnace. Refer to the wiring diagram inside the control box cover or Figures 40 - 45 (pages 34 - 39) for the wiring of your particular unit. Any other wiring methods must be acceptable to authority having jurisdiction.

! CAUTION:

Label all wires prior to disconnection when servicing controls. Wiring errors can cause improper and dangerous operation. Verify proper operation after servicing.

IMPORTANT NOTE: Proper line voltage polarity must be maintained in order for the control system to operate correctly. Verify the incoming neutral line is connected to the white wire and the incoming "hot" line is connected to the black wire. The furnace will not operate unless the polarity and ground are properly connected as shown in Figure 25.

Route all electrical wiring to the left side of the furnace. For installation of "A" Cabinet furnaces, allow sufficient slack in the wiring if an optional cooling coil cabinet is added at a later time. *Use of copper conductors is recommended.*

Connecting Power Supply Wires

1. Remove the furnace control panel cover.
2. Route wires (115 VAC) through the strain relief on the left side of the furnace control box (see Figure 24).
3. Connect the **hot** wire to the **black** pigtail lead, and the **neutral** wire to the **white** pigtail lead. Secure all connections with suitable wire nuts.
4. Connect the **ground** wire to the grounding screw.
5. Reinstall the control panel cover and secure with the original mounting screws.

Low Voltage Wiring

The thermostat must be installed according to the instructions supplied by the thermostat manufacturer. Low voltage connections (24 VAC) from the thermostat are wired to the terminal strip on the integrated control in the furnace.

NOTE: The thermostat must not be installed on an outside wall or any other location where its operation may be adversely affected by radiant heat from fireplaces, sunlight, or lighting fixtures, and convective heat from warm air registers or electrical appliances. The nominal anticipator setting is 0.4. (Refer to the thermostat literature for additional information.)

Five-conductor thermostat wire is recommended for 24 volt low-voltage circuit (2-wire is required for furnace only; 5-wire for heating and optional cooling systems). Refer to table 6 for thermostat wire information.

Connecting Thermostat Wires

1. Insert 24 volt wires through the plastic grommet just above the control panel.
2. Connect the thermostat wires to the furnace low voltage pigtails (see Figure 25).
3. Connect low-voltage circuit to the wall thermostat.
4. A hole may be made in the furnace cabinet to ease thermostat wiring. Make sure that the wiring is protected from the sharp edge of the added hole.

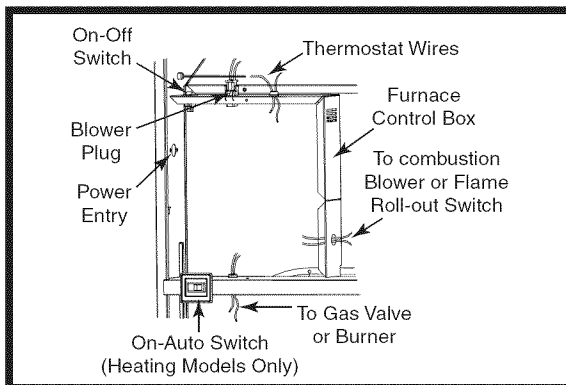

Figure 24. Control Panel (All Models)

Verifying Anticipator Setting

After the furnace is installed, check the thermostat anticipator against the nominal setting of 0.4.

1. Connect the milliamp meter in series with one of the gas valve's low voltage terminals.
2. Energize the gas valve.
3. Read the value of the milliamps.
4. Adjust the heat anticipator of the thermostat to the value on the milliamp meter. If the heat anticipator is set too high, the furnace may delay turning on. If set too low, the furnace may cycle frequently and not provide comfort to the homeowner.

Thermostat Wire Gauge	Recommended T'STAT Wire Length (Unit to T'STAT)	
	2-Wire (Heating)	5-Wire (Heating/Cooling)
24	55	25
22	90	45
20	140	70
18	225	110

Table 6. Thermostat Wire Gauge

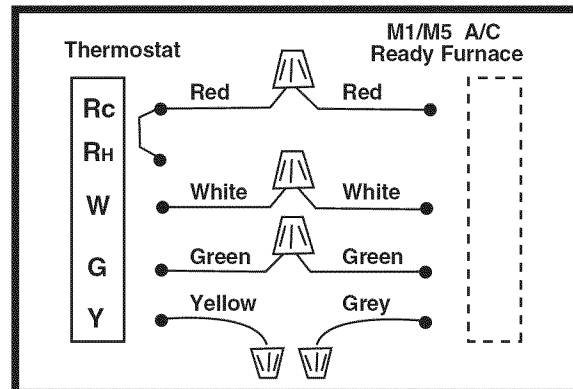

Figure 25. Thermostat Wiring For A/C Ready Models

Grounding

! WARNING:

To minimize personal injury, the furnace cabinet must have an uninterrupted or unbroken electrical ground. The controls used in this furnace require an earth ground to operate properly. Acceptable methods include electrical wire or conduit approved for ground service. Do not use gas piping as an electrical ground!

! WARNING:

All piping must conform with local building codes, or in the absence of local codes, with the most recent edition of the National Fuel Gas Code ANSI Z223.1 or (CAN/CGA B149.1 or .2). Failure to follow all safety warnings could result in serious injury, death or property damage.

This furnace may be installed with left or right side gas entry. When connecting the gas supply, provide clearance between the gas supply line and the entry hole in the furnace casing to avoid unwanted noise and/or damage to the furnace. Typical gas service hookup for this furnace is shown in Figure 26. Table 14 (page 37) lists gas flow capacities for standard pipe sizes as a function of length in typical applications based on nominal pressure drop in the line.

IMPORTANT NOTES:

- Some local regulations require the installation of a manual main shut-off valve and ground joint union external to the furnace (Figure 36). The shut-off valve should be readily accessible for service and/or emergency use. Consult the local utility or gas supplier for additional requirements regarding placement of the manual main gas shut-off.
- Gas piping must never run in or through air ducts, chimneys, gas vents, or elevator shafts.
- Compounds used on threaded joints of gas piping must be resistant to the actions of -liquefied petroleum gases.
- The main gas valve and main power disconnect to the furnace must be properly labeled by the installer in case emergency shutdown is required.
- Flexible gas connectors are not recommended for this furnace but may be used if allowed by local jurisdiction. Only new flexible connectors may be used. DO NOT reuse old flexible gas connectors.
- A drip leg should be installed in the vertical pipe run to the unit (Figure 36).
- All piping shall be black iron pipe, or equivalently sized steel tubing. Internally tinned copper tubing may be used for gas supply systems.

Fuel line installations other than typical installations shown in Figures 26 and 27 (page 17) must comply with the fuel piping provisions stated in the Federal Manufactured Home Standard (H.U.D. TITLE 24, PART 280) and the National Fuel Gas Code (ANSI-Z223.1/ NFPA-54).

- Optional fuel inlet lines are available for all gas furnace models to permit the addition of a 1/2" F.P.T. shut-off valve above the floor.

NOTE: Shut-off valve must be designed and listed for use with liquid petroleum (L.P. gas).

The gas supply to your home will either be Natural Gas or L.P. (bottle gas). Your furnace is factory equipped to operate on Natural Gas. If your gas supply is L.P. (bottle gas), you must contact a qualified serviceman or gas supplier to convert the furnace. Instructions for gas conversion are listed on page 18. Factory installed orifice sizes are listed in Table 10 (page 31).

For natural gas operation, the furnace is designed for 7" W.C. inlet pressure. Pressure is reduced to 3 1/2" W.C. by the pressure regulator in the gas valve. The maximum inlet pressure for the valve is 13" W.C.

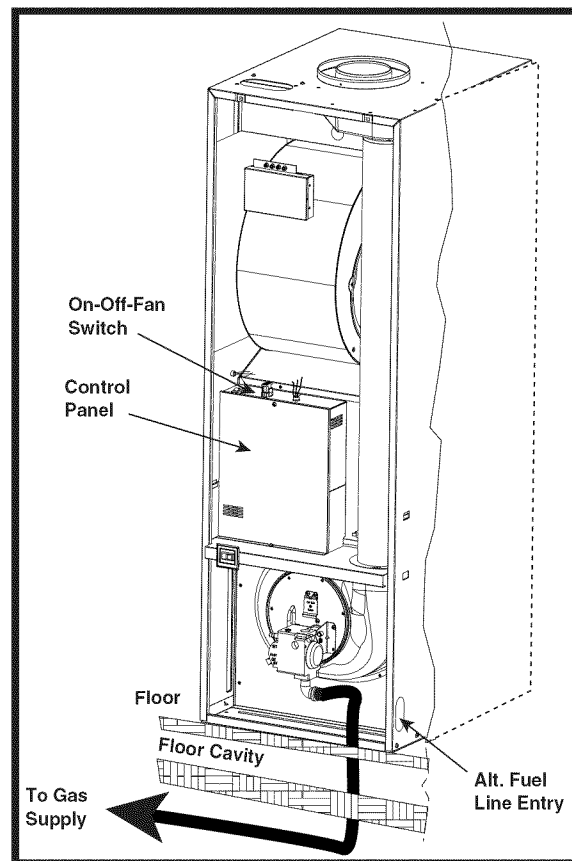

Figure 26. Typical Gas Piping

For L.P. gas, pressure to the gas valve must be more than 11" W.C. but not more than 13" W.C. Pressure is reduced to 10" W.C. by the pressure regulator in the gas valve.

⚠ CAUTION:

Furnace conversion must be performed by a qualified technician. Improper conversion can cause unsafe operation, explosion, fire and/or asphyxiation.

Oil Tank and Piping Installation

The following procedures are recommended as good practice. However, requirements of local codes and ordinances, H.U.D. Manufactured Home and Safety Standards or National Fire Protection Association must be satisfied, where they apply, for an approved installation.

- Use a tank capacity suitable for the application with a weatherproof, capped fill opening and a shielded vent to let in air as fuel is used.
- The inside of the tank must be clean before filling. All water, rust, sediment, and debris must be flushed out.
- A fuel or tank gauge (Figure 27) is recommended for easy checking of the fuel level. Check the gauge reading with a dipstick.
- Locate the storage tank conveniently near the home. If the fuel tank is installed above ground, the tank may rest 3 to 4 inches off the ground. Fuel tanks may also be buried if properly coated to resist corrosion. The vertical dimension from the bottom of the fuel tank to the fuel pump must not exceed 10 feet.
- Keep the tank filled, especially in the summer to reduce the accumulation of condensation.

One Line System

The one line system is highly recommended where vertical lift, from bottom of tank to pump, is less than eight feet (Figure 27). A single line hookup has the advantage of lower cost and quieter operation.

Two Line System

If a two pipe system is used or if oil is taken from the bottom of the tank, a filter is recommended. A two line system should only be used if vertical lift exceeds 8 feet.

1. Install the oil feed line as outlined in steps 1 - 6 below.
2. Install the oil pump bypass plug in the bottom return port.
3. Route the return line up through the furnace base to the return port of the pump. Route the other end of the line to the tank, using 3/8" O.D. copper tubing or 1/4" pipe with the ends capped.
4. Insert the return line through the second opening in the duplex bushing. If the bottom of the tank is lower than the pump intake, the tube should be inserted three or four inches from the tank bottom. If the bottom of the tank is higher than the pump intake, the return line should extend not more than 8" inside the tank.

Fuel line Hook-Up

1. Use a 3/8" O.D. copper tubing for the fuel line.
 - NOTE:** Cap the end with tape to keep out dirt while the line is being routed.
2. Install duplex bushing for two 3/8" lines in the top fitting of the tank. See Figure 27.
3. Insert one end of the tubing through the duplex bushing until it is three to five inches from the bottom drain. Tighten the bushing.
4. Route the line where it will not incur any damage. Make bends gradual and avoid kinks which might restrict oil flow.

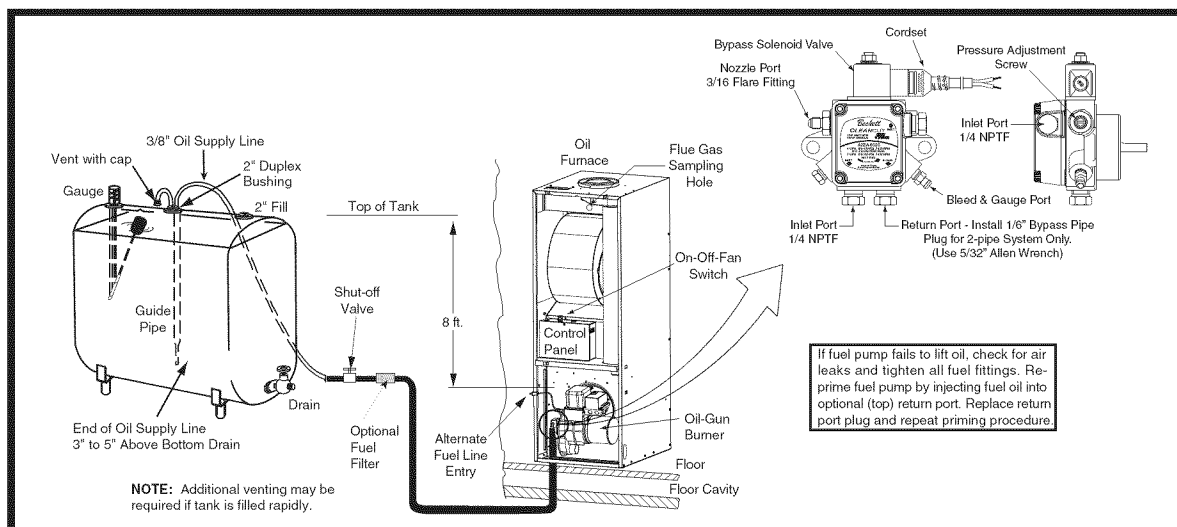

Figure 27. Typical Oil Piping for Above Ground (Single-Line) Supply

5. Open the furnace door and connect the oil line to the intake port on the pump. Tighten other port plugs on the pump. **NOTE:** Verify the oil line is airtight! Air leaks can cause the pump to lose prime and will create other problems such as nozzle failure, odors, rumbling noise, and false safety shutdown.
6. Insert the short length of the copper tube level with the bottom of the duplex bushing. Form the tube into an inverted “U” to serve as a vent.

Leak Check

To eliminate problems caused by air in the oil line, all connections in the oil supply line and all plugs, nuts, and fittings on the pump must be airtight. **NOTE:** This includes the nut that covers the pressure adjustment. It is important that the hook-up be done carefully and with a good flaring tool.

Prepare the burner for priming by attaching a clear plastic hose over the bleed port fitting and fully opening the pump bleed port. Use a suitable container to collect purged oil.

To ensure continuous operation, use a wire to jump terminals **T-T** (or **F-F**) on the primary control while burner is running.

After the piping to the furnace is complete, all connections must be tested for leakage. This includes pipe connections at the main gas valve, emergency shutoff valve and each joint or union. The soap and water solution can be applied using a small paintbrush. If any bubbling is observed, the connection is not sealed adequately and must be retightened. Repeat the tightening and soap check process until bubbling ceases.

Priming furnaces equipped with Honeywell R7184 primary control:

1. While the ignition is on, press for 1/2 second (or less), and release the reset button. The lockout time will be extended to 4 minutes.
2. If prime is not established within the 4 minutes, the control will lock out. Press the reset button to reset the control.
3. Repeat steps 1 & 2 (if needed) until the oil pump is fully primed.

Priming furnaces equipped with the Beckett 7505 primary control:

1. After the burner starts, press and hold the reset button until the yellow LED turns on (15 seconds). This indicates that the button has been held long enough.
2. Release the reset button. The yellow LED will turn off and the burner will start up again.
3. At burner start up, click the reset button while the igniter is still on. This transitions the control

to a dedicated pump prime mode, during which the motor, igniter and valve are powered for 4 minutes. The yellow LED will be on. **NOTE:** If prime is not established during the four minute pump prime mode, repeat step 3 until the oil pump is fully primed.

4. When oil flow is clear and free of air bubbles, close air-bleed valve and tighten. (Time to bleed air out will vary depending on length of oil line, number of bends, etc.)

Fuel Oil Type

Do not use fuel oil heavier than Grade No. 2. Grade No. 1 may be used where the oil supply is subject to low temperatures.

DO NOT USE GASOLINE, CRANKCASE OIL, OR ANY OIL CONTAINING GASOLINE.

WARNING:

Failure to keep supply of oil clean by various procedures described above may cause failure of certain components such as the fuel pump gears, check valve, shaft seal, or burner nozzle which may result in a burner fire.

Conversion to Propane (LP) Gas

This gas fired heating appliance was shipped from the factory for use with natural gas. However, the appliance can be converted for use with LP gas. Use the following procedure for gas conversion of the burner. See Table

Atmospheric and Direct Ignition Furnaces

1. Follow the instructions “How to Shut Off Gas” on pages 21 or 22.
2. Disconnect the gas pipe union and the electrical wires connected to the gas valve.
3. Remove the pilot tube and thermocouple from the gas valve (M1G).
4. Remove the gas valve assembly:
 - a. Remove screw(s) from gas valve bracket. Gas valve and spud may be removed. Orifice is located at the end of the spud (M1G or M1M) or remove three (3) bolts from U-shaped manifold plate and orifice assembly (M1B).
5. Replace the main orifice with the L.P. gas orifice supplied in the envelope located by the gas valve. Verify the orifice size matches the nameplate or Table 10 (page 31). **NOTE:** It is not necessary to convert the pilot orifice.

6. For Honeywell gas valves with the regulator converter (Figure 28, page 19):
 - a. Unscrew the pressure regulator cap and check for the letters NAT or LP.
 - b. Invert the cap and tighten until snug.
7. For Robertshaw gas valves with the regulator converter (Figure 29):
 - a. Remove the black cover and unscrew the converter located on top of the gas valve.
 - b. Invert the converter: for LP the red ring will be located at the bottom and the LP stamping on the converter will appear right side up.
 - c. Screw converter back into the regulator, hand tight plus 1/8 turn. Replace the black cover on the converter top to protect the threads.
8. Reassemble the burner assembly into the furnace.
9. Reconnect the gas piping and electrical wires to the gas valve.
10. Open the manual shut-off valve and follow the Lighting and Operating instructions on page 22.

High Altitude Conversion

High altitude conversion with this furnace depends on the installation altitude and the heating value of the gas. The installation of this furnace at altitudes above 2,000 feet must meet the requirements of the National Fuel Gas Code or local jurisdiction. In Canada, the requirements for high altitude are different and governed by CGA B149.1. Please consult your local code authority.

! WARNING:

The reduction of input rating necessary for high altitude installation may only be accomplished with factory supplied orifices. Do not attempt to drill out orifices in the field. Improperly drilled orifices may cause fire, explosion, carbon monoxide poisoning, personal injury or death.

This furnace is shipped from the factory with orifices and gas regulator settings for natural gas operation at sea level altitudes. At 2000 feet, the NFGC requires that this appliance be derated 4% for each 1000 feet of altitude. For example, the input needs to be reduced 8% at 2,000 feet, 12% at 3,000 feet and etc. This deration is in reference to the input rate and gas heating value at sea level. See Table 12 (page 32).

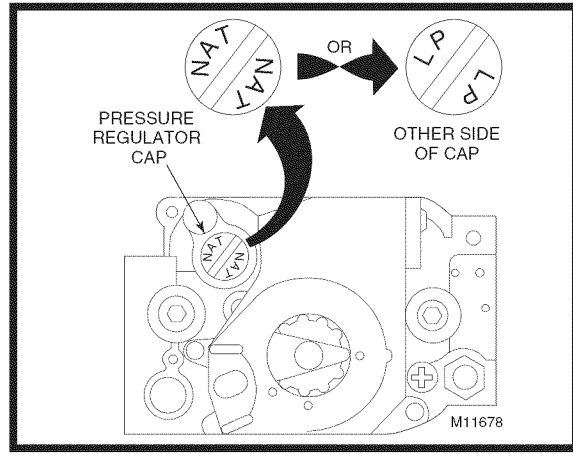

Figure 28. Honeywell Gas Valve

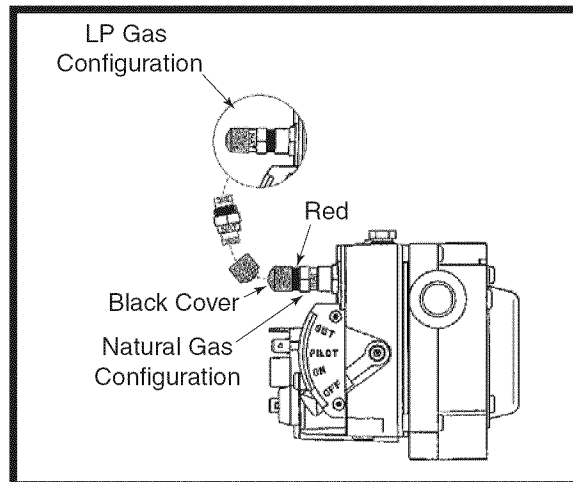

Figure 29. Robertshaw Gas Valve

Flue Gas Sampling

It may be necessary to take flue gas sampling from oil and gas furnaces (M5S and M1B Series Models) in order to check the performance after furnace installation. A flue gas sample may be taken from the heat exchanger, which is located behind the hole of the top-front of blower compartment.

1. Turn off all electric power to the appliance.
2. Remove the black plastic cap located above the blower. Do not discard cap.
3. Drill a hole through the top of the blower compartment. **NOTE:** Hole diameter should be same size as sampling tube.
4. Insert sampling tube through the drilled hole and into the heat exchanger.
5. After a complete check and adjustment of furnace performance, seal the drilled hole with a screw larger than the hole. **NOTE:** Seal the screw threads with silicon sealant - rated at least 500° F.
6. Plug the outside hole with the plastic cap removed in step 3.

STARTUP AND ADJUSTMENTS

PLEASE READ ALL SAFETY INFORMATION
BEFORE LIGHTING THE FURNACE

WARNING:

FIRE OR EXPLOSION HAZARD

WHAT TO DO IF YOU SMELL GAS

- Do not try to light any appliance.
- Do not touch any electrical switch; do not use any phone in your building.
- Leave the building immediately.
- Immediately call your gas supplier from a neighbors phone. Follow the gas suppliers instructions.
- If you cannot reach your gas supplier, call the fire department.

WARNING:

Before placing the furnace in service, it must be checked to ensure it is equipped for the type of gas being used. The burner flame must be observed and adjusted if necessary. Failure to observe this caution may result in unsafe operation, explosion and/or fire, or asphyxiation. See the Gas Supply and Combustion Air sections.

- The first lighting of the furnace after any home setup must be performed by a qualified service technician.
- If this appliance has a pilot that must be lit by hand, follow these instructions exactly.
- BEFORE LIGHTING: Smell all around the furnace for gas and next to the floor. Some gas is heavier than air and may settle on the floor.
- Use only your hand to push in the gas control lever. Never use tools. If the lever will not push in by hand, don't try to repair it. Force or attempted repair may result in a fire or explosion. Call a qualified service technician.
- Do not use this furnace if any part has been under water. Immediately call a service technician to inspect the furnace and to replace any part of the gas valve or control system which has been under water.

Lighting Instructions - Standing Pilot Models.

1. Set the thermostat to the lowest setting.
2. Turn off all electric power to the appliance.
3. Remove the furnace door.
4. Push in and move the gas control lever to the **OFF** position (Figure 30). **DO NOT FORCE!**
5. Wait 10 minutes to clear out any gas. If you smell gas, **STOP!** and read the Safety Information. If you don't smell gas, proceed to step 6.
6. Find pilot - follow metal pilot tube from gas control valve. Open hinged fire observation door. The pilot is found at the end of the pilot tube just left of the pilot shield (Figure 31).
7. Lightly depress the gas control lever and move it to the **ON** position. Release and move the lever to the **PILOT** position.
8. Move the control lever to **SET** and hold. Immediately light the pilot with a match. Continue to hold the control lever for about one (1) minute after the pilot is lit. **NOTE:** The pilot flame is adjustable by turning the adjustment screw located on the gas valve with a small screwdriver. See Figure 29.
9. Release the lever and it will spring back to the **PILOT** position. **NOTE:** Pilot should remain lit. If it goes out, repeat steps 4 through 8 above. If the lever does not spring back when released, immediately call your service technician or gas supplier. If the pilot will not stay lit after several tries, move the gas control lever to **OFF** and call your service technician or gas supplier.
10. Move the gas control lever to **ON**.
11. Turn on all electric power to the furnace.

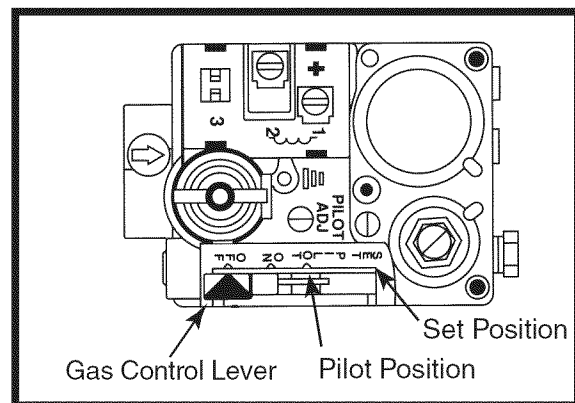

Figure 30. Standing Pilot Valve

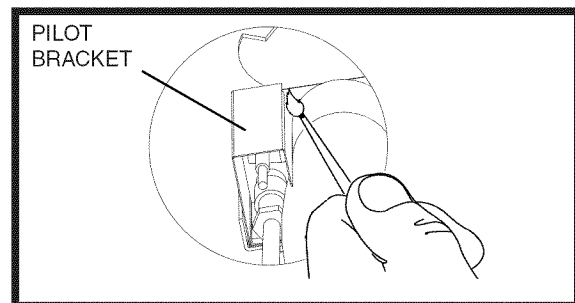

Figure 31. Lighting The Furnace

12. Set the thermostat mode to **HEAT** or a desired temperature setting and then **ON**.

! WARNING:

Close the hinged fire door. If door is left open or spring is broken it may allow products of combustion into the living space by the furnace blower, resulting in possible asphyxiation.

13. Replace the furnace door.

NOTE: In the event of any flashback or explosion, immediately shut off the furnace and call your service technician.

! WARNING:

Should overheating occur, or the gas supply fails to shut off, shut off the manual gas valve to the furnace before shutting off the electrical supply.

! AVERTISSEMENT:

En case de température excessive, ou s'il est impossible de couper l'alimentation en gaz, fermer le robinet manuel d'alimentation en gaz du générateur d'air chaud avant de couper l'alimentation électrique.

How to Shut Off Gas - Standing Pilot

1. Set the thermostat to the lowest setting.
2. Turn off all electric power to the appliance at the breaker or fuse box.
3. Remove the furnace door.
4. Push in the gas control lever and move to the left to the **OFF** position. **DO NOT FORCE!**
5. Replace the furnace door.

Operating Instructions for Direct Ignition Models M1M

Direct ignition furnaces do not have a pilot. Ignition is accomplished by a silicon carbide hot surface ignitor. A control module takes care of all timing functions. After lighting, the control module uses the ignitor as a flame sensor, shutting off gas should the flame go out. There are no external relays or timing devices. **Do not try to light this furnace by hand. The control module is not field serviceable.**

1. Set the thermostat to the lowest setting.
2. Turn off all electric power to the appliance.
3. Remove the furnace door and turn off the gas valve:
 - **Honeywell:** push in and turn the gas control knob clockwise to **OFF** (Figure 32)
 - **Robertshaw:** push the gas control lever to the **OFF** position (Figure 33). **Do not force!**
4. Wait ten (10) minutes to clear out any gas. If you smell gas, **STOP!** and follow the Safety Information on page 19. If you do not smell gas, proceed to next step 5.
5. Set the thermostat **MODE** the **ON** position.
6. Turn the gas valve **ON**:
 - **Honeywell:** push in and turn gas control knob counter-clockwise to **ON** (Figure 32).
 - **Robertshaw:** push the gas control lever to the **ON** position (Figure 33). **Do not force!**
7. Replace the furnace door.
8. Turn on all electric power to the appliance.
9. Change the thermostat mode to **HEAT** and the temperature selector to a desired temperature level. The igniter should light in approximately 75 seconds. If the appliance will not operate, see "How To Shut Off Gas - Direct Ignition" and call your service technician or gas supplier.

NOTE: In the event of any flashback or explosion, immediately shut off the furnace and call your service technician.

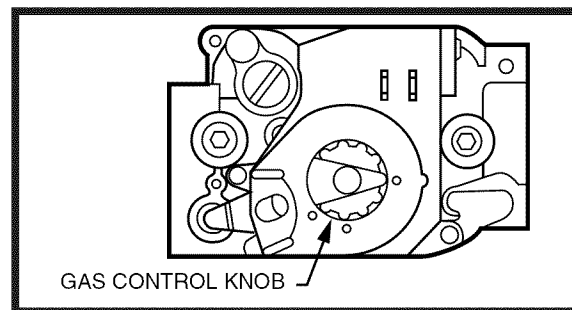

Figure 32. Direct Ignition Gas Valve - Honeywell

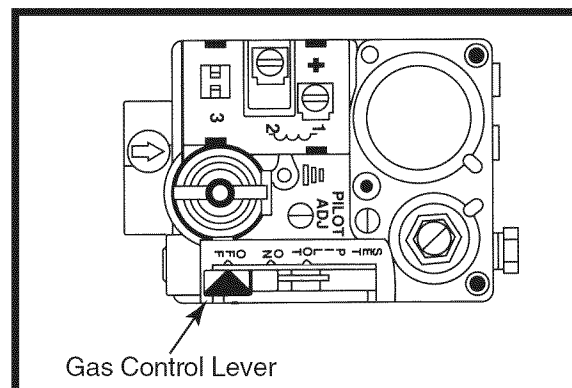

Figure 33. Direct Ignition Gas Valve - Robertshaw

How to Shut Off Gas - Direct Ignition

1. Set the thermostat to the lowest setting.
2. Turn off all electric power to the appliance before servicing unit.
3. Set the furnace On-Off Switch to **OFF**.
 - Honeywell (Figure 32): Turn gas control knob clockwise to **OFF**, Robertshaw (Figure 33): Push the gas control lever to **OFF**.
 - For oil, shut off all valves.
4. Replace the furnace door.

Operating Instructions for Oil Gun Furnaces

If your furnace model number begins with M5S*, the furnace is equipped with an ignition device which automatically lights the burner. **Do not try to light this furnace manually.**

1. Open all valves in the oil line.
2. Verify the fire door is closed.
3. Set the furnace On-Off switch to **ON**.
4. Set the thermostat to the desired setting.

NOTE: M5 oil gun furnaces may be converted to gas gun in the field by using the proper conversion kit listed in the RPL.

Operating Instructions for Gas Gun Models

If your furnace model number begins with M1B, the furnace does not have a pilot. Ignition is accomplished by a silicon carbide hot surface ignitor. A control module takes care of all lighting and timing functions. There are no external relays or timing devices. **Do not try to light this furnace by hand. The control module is not field serviceable.**

1. Before operation, smell for gas all around the furnace, especially near the floor because some gases are heavier than air and will settle on the floor. If you detect gas, STOP and follow all the safety instructions.
2. Set the thermostat to the lowest setting.
3. Turn off all electric power to the appliance.
4. Turn off the gas valve:
 - Honeywell: push in the gas control knob and turn clockwise to **OFF** (Figure 32).
 - Robertshaw: push the gas control lever to **OFF** (Figure 33). The lever cannot be placed in the off position unless it is pushed in slightly. **DO NOT FORCE!**
5. Wait ten minutes to clear out any gas. If you smell gas, STOP! and follow the safety information. If gas is not detected, proceed to the next step.
6. Set the **furnace On-Off** switch to the **ON** position.
 - Honeywell: turn knob on gas control counter clockwise to **ON**.
 - Robertshaw: push the gas control lever to **ON**.

7. Turn electric power to the appliance ON.
8. Set the thermostat to **HEAT** and/or the desired temperature setting. The furnace should light in approximately 45 seconds. If the appliance will not operate, follow the instructions "How to Shut Off Gas - Direct Ignition Furnace" (page 21) and call your service technician or gas supplier.

In the event of any flashback or explosion, immediately shut off the furnace and call your service technician.

How to Shut Off Gas - Oil & Gas Gun

1. Set the thermostat to the lowest setting.
2. Turn off all electric power to the appliance at the breaker or fuse box.
3. Set the thermostat MODE switch to **OFF**.
4. Turn the gas valve OFF:
 - Honeywell: push in and turn the gas control knob clockwise to the **OFF** position (Figure 32).
 - Robertshaw - push the gas control lever to the **OFF** position (Figure 33).
5. Replace the furnace door.

NOTE: M1B gas gun furnaces may be converted to oil gun in the field by using the proper conversion kit listed in the RPL

Burner Adjustments

Burner settings are made at the factory. However, these settings may change during shipping, handling, and installation. The following items should be checked and readjusted if necessary.

Gas Pressure

The gas pressure can be checked with a manometer at the pressure tap located on the side of the gas valve. The gas valve pressure regulator can be adjusted by removing the regulator selector stack and turning the slotted insert located directly under the selector stack. The regulator selector stack must be secured in place before each pressure reading is taken. Natural gas manifold pressure should be 3.5" W.C. and L.P. gas manifold pressure should be 10" W.C. Replace the gas pressure tap plug on the gas valve.

Pilot Flame (Standing Pilot Only)

The pilot flame can be adjusted by turning the pilot adjustment screw, located on top of the gas valve (See Figure 30, page 20). The pilot flame height should be between 3/4" and 1." The flame tip should be visible just above the pilot bracket when viewed through the observation door. The same pilot orifice is used with both natural and LP gas.

Combustion Air

In order for the flame to burn efficiently, it must receive adequate combustion air. The amount of combustion air required varies according to altitude, actual B.T.U. content of the fuel, gas pressure, conversion to another gas and other factors. The burner flame should be observed and any necessary adjustments made before the furnace is placed into service. See Table 7 for Factory Air settings.

CAUTION:

- **Combustion air adjustment must be made only by a qualified technician. Improper air adjustment may cause unsafe operation, explosion and/or fire asphyxiation.**
- **If the input to the furnace is too great because of excessive gas pressure, wrong size nozzle or orifice, high altitude, etc., the burner flame will be sooty and can produce carbon monoxide, which could result in unsafe operation, explosion and/or fire or asphyxiation.**

Model	Nat. Gas	LP Gas	Oil
66,000	3.5	3.5	3.5
86,000	5.3	6	5

Table 7. Factory Combustion Air Settings

Gas Gun

Combustion air box adjustment is made to the main burner by loosening the two lock nuts on the plastic air shutter, located on the left side of the burner blower housing. Air shutter adjustment line is located on the same side of the blower housing. Turn the plastic shutter to a smaller number (counter clockwise) for less air to a larger number (clockwise) for more air. Gently tighten the lock nuts after completing the adjustment. For best results, use instrument to measure between 8 - 9% CO₂, after the combustion air has been adjusted. **Note:** Do not over-tighten the lock nuts. This may damage the plastic air shutter.

Oil Gun Only

It is recommended that the CO₂ and Smoke levels be measured for maximum performance. CO₂ readings should be 10 - 11% for 66,000 BTUH furnaces and 12 - 13% for 86,000 BTUH furnaces.

The Smoke should be N0. 0 on the Bacharach Scale, and 0 to 0.02 negative draft over fire.

Electrode Setting (Oil Gun Only)

Poor ignition of the oil spray may result if the electrodes are not adjusted as shown in Figure 34. Do not permit any electrodes to be grounded to any surface.

Switching Ignition Control between Interrupted and Intermittent Duty (Oil Gun Only)

Honeywell and Beckett oil primary controls can be switched between interrupted and intermittent ignition control. To switch from interrupted duty (Factory set) to intermittent duty, remove the blue wire from the quick-connect terminal. Attach the burner motor and igniter wire to the burner motor (orange) control terminal by splicing or adding tab adapters. Seal and isolate any bare wires.

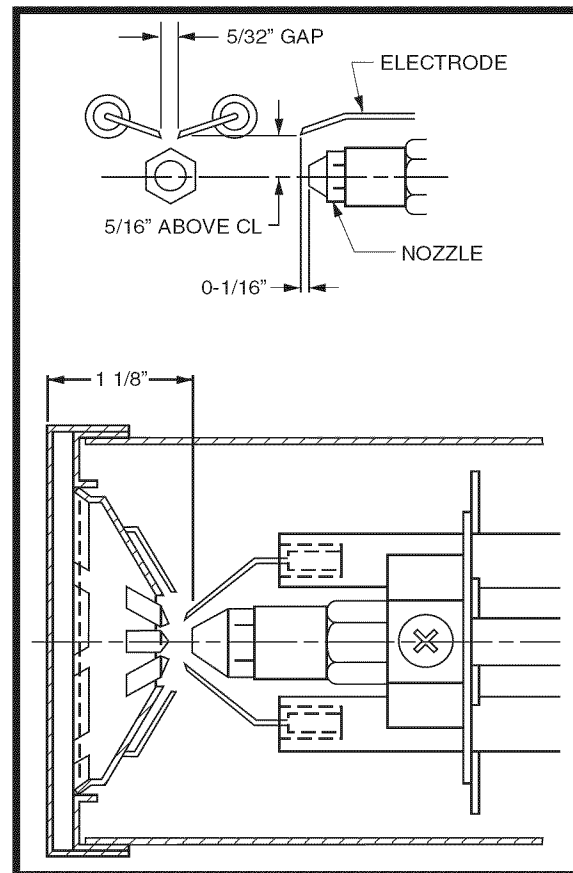

Figure 34. Oil Gun electrode Position

OPERATING SEQUENCE

Standing Pilot

1. On a call for heat, the thermostat contacts close, supplying 24 VAC to the gas valve. When energized, the valve steps open at a reduced flow and opens fully within 14 seconds.
2. When the call for heat is satisfied, the thermostat contacts open, shutting off gas flow.

Standing Pilot w/Induced Draft Blowers

1. On a call for heat, the thermostat contacts close, supplying 24 VAC to the relay.
2. The relay contacts close and the induced draft motor energizes.
3. When the inducer starts, the air pressure switch closes at -0.20 W.C. differential pressure and energizes the gas valve. The valve steps open at a reduced flow and opens fully after approximately 14 seconds.
4. When the call for heat is satisfied, the thermostat contacts open, the gas valve shuts off gas flow, and the induced draft blower stops.

M1M Models with Direct Ignition

1. On a call for heat, the thermostat contacts close, supplying 24 VAC between terminals **C** and **W** of the control module.
2. When the inducer starts, the air pressure switch closes at -0.20 W.C. differential pressure and energizes the gas valve.
3. After a 45 second purge, the ignitor is energized for a 30 second warm-up period. After warm up, the gas valve opens. **NOTE:** The time for ignition is approximately 6 seconds, after which the gas valve either remains open if flame is sensed, or closes if flame is not sensed.
5. If flame is not sensed, the sequence repeats four more times before a lockout occurs. To reset, wait 30 seconds and then interrupt the 24 VAC power by turning the room thermostat below room temperature, then returning it to the original set point.
6. If flame does not establish on the 5th attempt (initial fire + 4 re-tries), the control de-energizes the gas valve, the **red** LED flashes 4 times, and the furnace locks out heat operation for 1 hour. See Table 9 (page 29).
7. If a flame is present, the control energizes the main blower on heat speed 30 seconds after the gas valve opens.
8. When call for heat is satisfied the thermostat contacts open, the gas valve shuts off gas flow and the combustion blower remains on for a 30 second post-purge period.
9. The main blower is de-energized after a 120 second blower off delay.

Oil Gun Furnace with Honeywell R7184 / Beckett 7505 Control - M5S Models

1. When a call for heat is initiated, there is a 2 to 6 second delay while the control performs a safe start check.
2. The ignition and motor are turned on and a flame should establish within a 15-second lockout time. **NOTE:** Burner will prepurge for 15 seconds if equipped with Honeywell R7184B or Beckett 7505B Control.
3. If flame is not sensed within the 15-second lockout time, the control shuts down on safety lockout and must be manually reset by pushing the reset button on the control. If control locks over three times in a row, the control enters restricted lockout. To reset Honeywell R7184: Hold down the reset button for 45 seconds until the LED flashes once. Beckett 7505: Hold down reset button for 15 seconds until the **red** LED turns off and the **yellow** LED turns on.

WARNING:

If furnace still doesn't light, turn the furnace off as described above and call your technician. In the event of flashback or explosion, immediately shut off furnace and call your service technician.

4. After flame is established, the ignition remains on for 10 seconds to ensure flame stability. It then turns off.
5. The circulating air blower will energize after the temperature fan switch closes.
6. The furnace runs until the call for heat is satisfied.
7. The circulating air blower will de-energize when the temperature fan switch opens.

Gas Gun Models

1. On a call for heat, the furnace control begins an ignition sequence which lasts approximately 45 seconds.
2. After this sequence, the control module tests to see if flame is sensed. If it has, the furnace continues to heat until the thermostat is satisfied.
3. If the burner has not lit, the ignition sequence is repeated a maximum of two more times. If flame is not sensed after three attempts, the control enters Lockout and no further attempts to light the burner will occur. If Lockout occurs, contact a qualified service technician for assistance.

4. When call for heat is satisfied, the thermostat contacts open and the gas valve shuts off gas flow.

! WARNING:

Should overheating occur, or the gas supply fails to shut off, shut off the manual gas valve to the furnace before shutting off the electrical supply.

! AVERTISSEMENT:

En case de température excessive, ou s'il est impossible de couper l'alimentation en gaz, fermer le robinet manuel d'alimentation en gaz du générateur d'air chaud avant de couper l'alimentation électrique.

FURNACE CONTROLS & FUNCTIONS

Furnace On-Off Switch

This switch turns electrical power to the furnace on and off. The switch must be set in the **ON** position for the furnace to operate. For M1G models, in warm weather there is a possibility of the blower turning on periodically or operating continuously due to a heat buildup within the furnace by a combination of warm weather and heat from the pilot. This is normal operation as long as there is power to the furnace and the furnace On-Off switch is in the **ON** position. If blower operation is not desired, the furnace On-Off switch may be set in the **OFF** position to cut the electrical power to the furnace. See Figure 35.

Limit Control

This furnace is protected by two high temperature safety limit switches. The auxiliary (upper) limit switch and the high temperature (lower) limit switch are automatic reset types. If either limit trips, the burner will shut off. If either limit switch trips off again soon after resetting, set the furnace furnace On-Off switch to the **OFF** position and call your authorized serviceman. See Figure 35.

Gas Valve

The gas valves for the gas furnaces are a 100% shut-off type and will fail safe, if for some reason the gas is turned off. The valve is a "step-open" type for M1G models and "slow-open" for M1M and M1B models which means it opens to a low-fire position, and after a few seconds, "steps-open" to high-fire.

Roll Out Switch (M1G - 056 & 070)

The furnace is protected by a manual reset safety switch located on the bottom left hand side of the combustion pipe.

Oil Burner Primary Control

The primary control for oil gun furnaces starts the burner, monitors a safe operating cycle, and shuts the burner off at the end of a heating cycle. The control uses a light sensing transducer to determine if fuel ignition has been successfully attained. If ignition is not attained by the end of the safety ignition timing period, the control shuts the burner off and enters "lock-out." See Figure 35.

Summer Cooling - (B, C, & D Series)

Your furnace is A/C ready, equipped with A/C relay and transformer. The unit is equipped to use a 4-wire thermostat. When using a 5-wire thermostat, RC and RH should be jumped (see instructions included with thermostat).

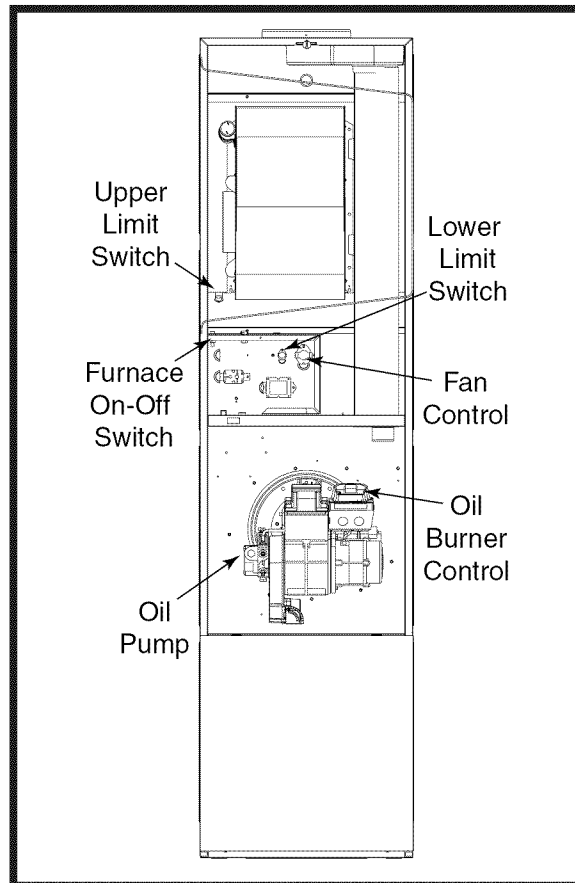

Figure 35. Furnace Controls - Oil Furnace

TROUBLESHOOTING

Standing Pilot Models

Main Burner Does Not Ignite

1. Check the electrical supply to the furnace.
2. Verify the furnace furnace On-Off switch is in the **ON** position.
3. Check for proper thermostat operation.
4. Check for broken or open thermostat wires.
5. Verify the insulation located on the inside of the front panel is glued securely around the fan switch and the limit switch.
6. Shut off the electrical supply to the furnace and remove the electrical box cover.
7. Check for a defective transformer or blown fuse.
8. Check electrical circuit for proper grounding, polarity, and make sure the electrical connections are tight.
9. Check the limit switches. Did they fail to close?
10. Replace the electrical box cover and restore electrical power to the furnace. Turn the furnace On-Off switch to **ON** and raise the thermostat setting above room temperature.
11. Check for 24 VAC at the gas valve. Replace the valve if the pilot is established and it does not open when powered with 24 volts.

Powered (24 VAC) Gas Valve - No Main Flame

1. Verify the manual shut-off valve is **OFF**.
2. Check the pilot flame. It must be established.
3. Check the gas valve control lever. It must be in the **ON** position.
4. Check incoming gas pressure.
5. Replace the gas valve if the main burner does not come on under the above conditions.

Pilot Will Not Light or Goes Out

1. Check the incoming gas pressure.
2. Check for the proper pilot orifice. See specifications on the furnace nameplate.
3. Check for proper pilot flame adjustment. See Burner Adjustment section (page 22).
4. Verify the thermocouple millivoltage. If reading is not between 18 - 30 mv., the gas valve electromagnet may be defective. Replace the gas valve if necessary.
5. Verify the pilot shield is in place.
6. Check for gas leaks (page 18).
7. Check the flue assembly for air leaks.
8. See lighting procedures (pages 20 - 22).

Main Flame Is Not Burning Properly

1. Check the manifold gas pressure.
2. Check for the correct main burner orifice. See furnace nameplate for specifications.
3. Check the flue for any blockages or loose connections.
4. Check the combustion air passages for blockage.

High Gas Bills

- a. Verify the proper orifices are being used.
- b. Check the return air system. Is it clear and free of blockage?
- c. Check the furnace filter. Is it clean or need replacing?
- d. Verify the home is insulated, windows and doors fit tightly, and there are no leaks in the heating duct system.
- e. Check the room thermostat. Is the setting higher than necessary? Low humidity requires higher temperatures for the same level of comfort. Check for proper humidity level in the home.

Direct Ignition Furnaces Including Gas Gun M1B Series (see Table 9, page 29)

Burner Motor won't Run - T-stat Calls for Heat

1. Check the electrical supply to the furnace.
2. Verify the furnace furnace On-Off switch is in the **ON** position.
3. Defective thermostat circuit - white and red thermostat low voltage leads (M1/M5M, M1/M5B models). If the burner motor or combustion fan runs, check:
 - Thermostat connections
 - Thermostat
4. No voltage to control module - determine if 24 volts (or 120 volts) is available to the control module. If voltage is not available check for:
 - Blown fuse, defective transformer, circuit breaker, no electrical supply.
 - Limit switch open.
 - Loose connections.

Combustion Blower Runs - No Flame

1. Defective centrifugal switch (M1B Model).
 - Check the operation of centrifugal switch by removing end bell of the burner motor.
 - Clean contacts of motor.
 - If the contacts are closed, replace the motor.
2. Defective pressure switch (M1M & M1G - 077, 090 Models) - check air tube and electrical connections.
3. Burner in purge mode - allow 75 seconds for flame establishing period.
4. Check for proper electrical connections at purge timer, control box, or gas valve.
5. Check for gas supply - gas line valve on, control lever on.

Control Module is Powered - Ignitor won't Heat Up

1. Disconnect ignitor leads at AMP receptacle and check for 120 volts at the plug during ignition sequence.
2. Replace ignition control if 120 volts is not available at AMP plug during ignition sequence.

120 VAC Is Available At AMP Plug - Ignitor Does Not Heat Up

1. Disconnect power to the furnace.
2. Disconnect AMP plug to the ignitor, and check ignitor resistance with an ohm meter. Set on RX1 scale.
 - Normal reading should be 40 - 75 ohms.
 - If above or below this rating at room temperature change ignitor.
3. Check for continuity from ignitor receptacle to burner.

Main Flame Ignites - Burner Locks Out

- Ignition control is not properly grounded.
- Defective ignition control.
- Improper polarity of 120 volt power supply.
- Ignitor has hairline crack.
- Improper gas pressure or burner air adjustment is not allowing flame to contact ignitor tip for flame rectification.
- Misaligned ignitor does not allow flame to contact ignitor tip for flame rectification.

Burner Short Cycling - Thermostat Calls for Heat, Limit Switches Closed

- Check for polarity.
- Check ground.
- Check flue.
- Check combustion air.
- Check gas pressure.
- Check orifice.
- Check the position of ignitor, a normal reading should be 40-75 ohms.

24 Volts Supplied To Gas Valve During Ignition - No Main Gas Flow

- Gas valve may be defective. Replace if necessary.
- Gas piping may be plugged. Check for adequate gas supply to gas valve at union.

Burner Operates - Insufficient Heat

- Check thermostat for proper setting and location. Thermostat should not be located where it will be affected by another heat source.
- Check for clean filter and proper air flow.
- Check burner for proper gas firing rate.
- Be sure unit is not undersized for its thermal load.
- Check thermostat anticipator. The nominal setting is 0.4.

Burner Flame Without Motor Running

- Gas valve stuck open, check gas valve for proper operation (replace if necessary) and inspect heat exchanger.
- Check for 115 volts to the combustion blower motor; replace if necessary.
- If no power to combustion blower then check wiring and control module; replace if necessary.

Circulation Air Blower Will Not Operate Even Though The Burner Does Operate

- Check thermostat **G** connection.
- Check wiring to motor.
- Check for a defective motor.

Oil Gun - Honeywell R7184 or Beckett 7505 Controls Only - M5S Series.

Burner does not start with a call for heat.

- Check the electrical supply to furnace.
- Verify the furnace door switch is in the **ON** position.
- Check for line voltage (115 VAC) at the oil primary control.
- Check indicator LED with burner off, no call for heat (no flame). See Table 9 (page 29).
 - If green LED indicator is on, the cad cell is seeing stray light or the cad cell of controller is defective.
 - If green LED indicator is off, go immediately to step 5.
 - If LED indicator is flashing (red or green on Beckett 7505 control), refer to the next step 1 below - Reset primary control.
- Jumper **T** to **T** terminals on primary control.
 - If burner starts, check thermostat or limit wiring connections.
 - If burner does not start, turn off power. Check all wiring connections.
 - If burner does not start, replace primary control.

Burner starts and then locks out on safety with Honeywell R7184 LED indicator flashing ½ second on, ½ second off. For Beckett 7505 control, the red LED will flash.

1. Reset primary control: To reset the control from (soft) lockout, the button needs only to be pressed and released. If the R7184 control is in restricted mode, press and hold the button for 45 seconds - until the LED flashes once. If the 7505 control is in restricted mode, press and hold the button in for 15 seconds until the red turns off and the yellow LED turns on.

NOTE: Restricted Lockout: If the control locks out three times in a row without a complete heat cycle between attempts, the lockout becomes a restricted (hard) lockout.

2. If the LED indicator stops flashing and the ignition remains off, the primary control could be defective. If line voltage is present at the igniter terminals, and there is no ignition, the igniter is likely defective and needs to be replaced.
3. If the stops flashing, burner turns on, but the control locks out again, check the cad cell. If

the cad cell is operational, replace the primary control.

4. If the LED continues to flash at the interval listed above, verify that the control is not in restricted mode. If in restricted mode, reset it. If not in restricted mode, replace the control.
5. If the (LED indicator for R7184 control; green LED for 7505 control) stays off while the flame is on, check the cad cell sighting for view of the flame.
6. If the burner locks out, check the cad cell resistance. (See Table 8)
7. If the burner stays running, the system is operational.
8. If the (LED indicator for R7184 control; green LED for 7505 control) is off, check the cad cell assembly after disconnecting the line voltage. Burner will not start and the LED indicator is flashing at 2 seconds on, 2 seconds off for R7184 (or the green LED is flashing for 7505).

- Hold the reset button down for 1 - 2 seconds. If LED indicator continues to flash, wait for 60 - 70 seconds. If it still continues to flash, replace the primary control.
- **Honeywell R7184 control:** To check cad cell resistance, press and release the button during the run mode, with the igniter off. The LED will flash to indicate the cad cell resistance. For proper burner operation, it is important that the cad cell resistance is under 1600 Ohms. For cad cell resistance, see Table 8.
- **Beckett 7505 control:** To check cad cell resistance, unplug the cad cell leads (yellow wires) from the control. Measure the resistance with a meter in the conventional way (when a flame is present). For proper burner operation, it is important that the cad cell resistance is under 1,600 Ohms.

LED Flashes (Ohms)	Cad Cell Resistance
1	0-400
2	400-800
3	800-1600
4	>1600

Table 8. Cad Cell Resistance when sensing flame

OPTIONAL ACCESSORIES

Necessary when the Furnace is Used with Some Central Air Conditioners

If an air conditioner is installed that does not use the furnace blower for air distribution and operates independently of the furnace, the thermostat system must have an interlock to prevent the furnace and air conditioner from operating at the same time. This interlock system usually contains either a "Heat-Cool" switch which must be turned to one of the positions to activate heat or cool operation, or a positive "OFF" switch on the cooling thermostat.

The furnace must also be equipped with an automatic damper to prevent cold air from being discharged up around the heat exchanger (NORDYNE p/n 901996 for furnaces without coil cavity, or p/n 901083 with coil cavity). See Figure 36 or 37. Cold air may cause condensation inside the heat exchanger which can rust and lead to early failure.

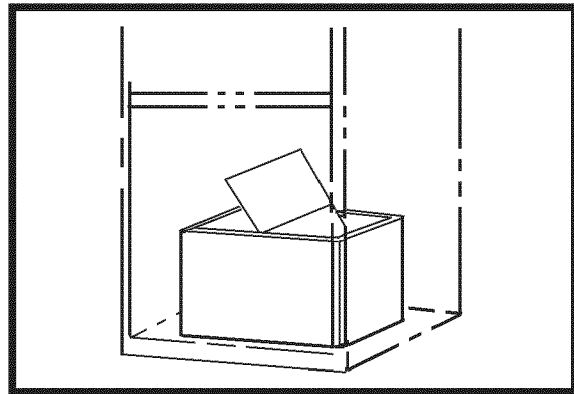

Figure 36. Coil Cavity Damper

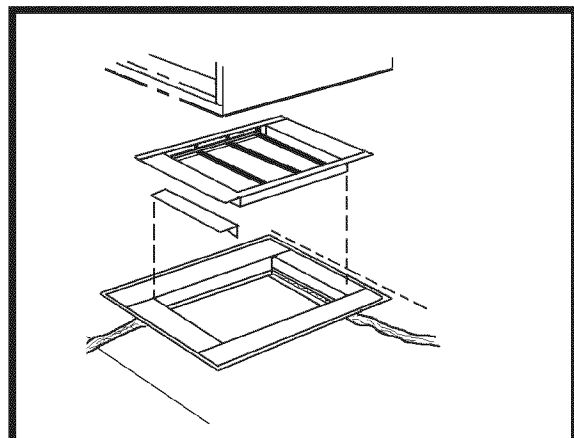

Figure 37. Damper without Coil Cavity

Control Module Status Indicators - M1M Series	
Red LED Indicator	Status
Steady ON	Control OK
Steady OFF	No power
Rapid flash	False flame or internal control fault
One flash	Limit switch is open
Two flashes	Pressure switch is open
Three flashes	Pressure switch is stuck closed
Four flashes	Lockout due to failed ignition
Five flashes	L1 neutral reversed or L1 voltage not present on L1

Flame Status - A Yellow LED labeled "Flame" is provided to indicate flame status. When flame is sensed, the flame LED is lit. If flame sense is weak, yellow LED will flash.

Control Module Status Indicator - M1B	
Red LED Indicator	Status
One flash	The control is in lock-out because the inducer centrifugal switch is or was stuck closed.
Two flashes	The control is in lockout because the signal was not received by the control that the inducer centrifugal switch had closed within the time.
Three flashes	The control is in lockout because a failed ignition attempt, a gas valve error, or a false flame sensed during the warm up period. If false flame has been sensed, the control will return to normal operation, and repeat ignition sequence when the false flame is not present.
Four flashes	The control is in lockout due to a failure within the control board

Control Module Status Indicator - M5S Series

The LED indicator(s) on the oil primary control provides lockout, recycle and cad cell indications.

Honeywell R7184 Control	
Green LED Indicator	Status
On	Cad cell is sensing flame (could be flame or stray light)
Off	Cad cell is not sensing flame
Flashing - 1/2 sec. on, 1/2 sec. off	Lockout/Restricted Lockout
Flashing - 2 sec. on, 2 sec. off	Recycle

Beckett 7505 Control		
LED Indicator Color	On Continuously	Flashing
Red	Restricted (hard) lockout	Soft lockout
Green	Cad cell is sensing flame - (could be flame or stray light)	Recycle
Yellow	Pump prime mode or reset button currently held for 15+ sec.	N/A

Table 9. Control Module Status Indicators

OPTIONAL ADD-ON AIR CONDITIONING

Whether split system or single package, an energy-saving NORDYNE Air Conditioner is available that has been designed specifically for manufactured housing applications and can best handle your home comfort needs. Ask your dealer or contractor about NORDYNE add-on central air conditioning systems.

Single package unit includes cooling coils, compressor, and vertical discharge fan. This type of unit connects with the existing home air duct system (an optional close-off damper is required with the furnace).

Split system unit with vertical discharge for quiet operation connects with NORDYNE cooling coil furnace (optional coil cavity required with "A" model furnaces).

MAINTENANCE

Homeowner Information

- On some closet installations, the return air opening to the furnace may be on the floor, in the door, in the side wall of the closet, or any combination of these. The upper grille on the front of the furnace admits return air to the blower. Return air must be provided back to the circulating blower in order to provide air distribution. See Figure 38.
- Filters - At least twice each season (more often in dusty areas) remove and clean the air filters with a vacuum or with warm water and soap. Reinstall when dry. Also clean dust and lint around furnace and in the furnace vestibule.
- During extremely cold weather, ice may form on the furnace roof jack (Figure 39). Small amounts of ice forming on the roof jack will present no problems to proper furnace operation. Excessive ice formation could restrict the combustion air supply to the burner, causing inefficient burner operation. If excessive ice has formed on the air inlet or exhaust portions of the roof jack, it must be carefully removed.

Installer Information

All furnaces need periodic service at the beginning of each heating season. Call your serviceman to:

- Remove the air circulator and clean all dust and lint from the unit with a stiff bristle brush.
- Inspect the combustion chamber blower compartment, flue collar and Roof Jack.
- Check the gas valve (if applicable) and fuel line connections for leaks.
- Make any adjustments necessary for good operation.

WARNING:

Use of furnace or air conditioning components that are not included in the certification of this appliance may create a hazard, invalidate the certification, and in many states, make installations illegal. Listed NORDYNE air conditioning components are specified on the furnace label.

Additional Oil Furnace Maintenance

In addition to the preceding, the following should be performed by a qualified service contractor at least once each season for oil-fired furnaces:

- Replace the oil nozzle with the type nozzle specified for your furnace.
- Clean, adjust and replace if necessary the spark electrodes.
- Reset the nozzle/drawer assembly to factory specifications.
- Clean the inside of the furnace heat exchanger and replace the combustion liner if necessary.
- Clean or replace the oil filter element at the oil tank.
- Adjust the burner for top efficiency and check to make sure all fittings are leak-tight.

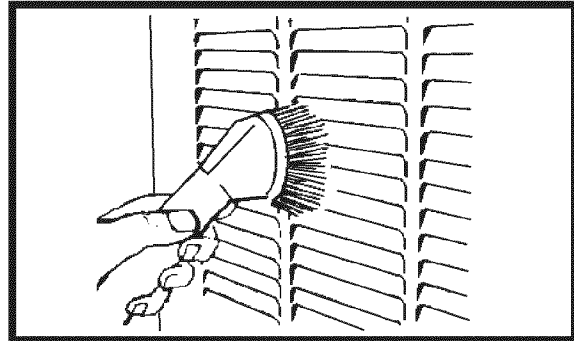

Figure 38. Periodic Cleaning

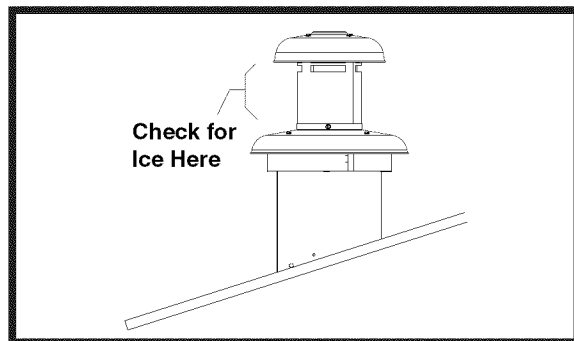

Figure 39. Roof Jack

Furnace Model No	Input MBtu/h	Output MBtu/h	Orifice No		E.S.P. In WC	Pilot Burner	Ignitor Direct	Comb. Blower	Motor Hp	A/C Ready Tons
			Nat.	LP						
M1GB 056	56	45	29	45	0.3	x			1/4	3
M1GB 070	70	57	24	42	0.3	x			1/4	3
M1GB 077	77	62	21	40	0.3	x		x	1/4	3
M1GB 090	90	72	17	36	0.3	x		x	1/4	3
M1MB 056	56	46	29	45	0.3		x	x	1/4	3
M1MC 056	56	46	29	45	0.3		x	x	1/2	4
M1MB 070	70	57	24	42	0.3		x	x	1/4	3
M1MC 070	70	57	24	42	0.3		x	x	1/2	4
M1MB 077	77	62	21	40	0.3		x	x	1/4	3
M1MC 077	77	62	21	40	0.3		x	x	1/2	4
M1MB 090	90	72	17	36	0.3		x	x	1/4	3
M1MC 090	90	72	17	36	0.3		x	x	1/2	4
M1BB 066	66	53	26	43	0.3		x	x	1/4	3
M1BC 066	66	53	26	43	0.3		x	x	1/2	4
M1BB 086	86	68	18	37	0.3		x	x	1/4	3
M1BC 086	86	68	18	37	0.3		x	x	1/2	4
M5SB 066	66	56	.50 Gph		0.3		x	Burner Model:	1/4	3
M5SC 066	66	56	.50 Gph		0.3		x	AF-10	1/2	4
M5SB 086	86	73	.65 Gph		0.3		x	Spray Angle:	1/4	3
M5SC 086	86	73	.65 Gph		0.3		x	80° A	1/2	4
NOTES:	<ul style="list-style-type: none"> • Electrical Supply - 120 volts, 60HZ, 1 Ph. Fuse or Breaker - 15 amps • Temperature Rise - 45° F to 75° F • High Altitude - See Table 12 (page 32). For Canadian Altitudes (2,000' to 4,500'), reduce the gas manifold pressure to 3.0" W.C. for natural gas and to 8" W.C. for LP gas. 						<ul style="list-style-type: none"> • Thermostat Circuit - 24 volts, 60HZ, 30 vac • Normal Anticipator Setting - 0.4 • Manifold Pressure - Natural Gas: 3.5" w.c. LP Gas: 10" w.c. 			

Table 10. M1/M5 Furnace Specifications - Factory Settings

FURNACE MODEL	ORIFICE SIZE AND OUTPUT CAPACITY	ALTITUDE - FEET									
		SEA LEVEL	2,000	3,000	4,000	5,000	6,000	7,000	8,000	9,000	10,000
M1M/M1G - 056	Orifice Size - Nat. Gas	29	29	30	30	30	30	31	31	31	32
	Orifice Size - LP	45	46	47	47	47	48	48	49	49	50
	Output - MBTUH	45.4	41.8	40.1	38.5	37.0	35.5	34.1	32.7	31.4	30.2
M1M/M1G - 070	Orifice Size - Nat. Gas	24	25	26	27	27	28	28	29	29	30
	Orifice Size - LP	42	42	43	43	43	44	44	45	46	47
	Output - MBTUH	56.7	52.3	50.2	48.2	46.2	44.4	42.6	40.9	39.3	37.7
M1M - 077	Orifice Size - Nat. Gas	21	23	23	24	25	26	27	28	28	29
	Orifice Size - LP	40	41	42	42	42	43	43	44	44	45
	Output - MBTUH	61.7	56.9	54.6	52.4	50.3	48.3	46.4	44.5	42.7	41.0
M1G - 077	Orifice Size - Nat. Gas	21	23	23	24	25	26	27	28	28	29
	Orifice Size - LP	40	41	42	42	42	43	43	44	44	45
	Output - MBTUH	59.9	55.2	53.0	50.9	48.9	46.9	45.0	43.2	41.5	39.8
M1M - 090	Orifice Size - Nat. Gas	17	18	19	19	20	21	22	23	24	26
	Orifice Size - LP	36	37	38	38	39	40	41	41	42	43
	Output - MBTUH	71.7	66.1	63.5	60.9	58.5	56.1	53.9	51.7	49.7	47.7
M1G - 090	Orifice Size - Nat. Gas	17	18	19	19	20	21	22	23	24	26
	Orifice Size - LP	36	37	38	38	39	40	41	41	42	43
	Output - MBTUH	69.7	64.2	61.7	59.2	56.8	54.6	52.4	50.3	48.3	46.3
M1B - 066	Orifice Size - Nat. Gas	26	27	28	28	28	29	29	30	30	30
	Orifice Size - LP	43	44	44	44	45	45	46	47	47	48
	Output - MBTUH	52.6	48.5	46.6	44.7	42.9	41.2	39.6	38.0	36.5	35.0
M1B - 086	Orifice Size - Nat. Gas	18	19	19	20	21	22	23	24	26	27
	Orifice Size - LP	37	38	39	39	40	41	42	42	43	43
	Output - MBTUH	68.2	62.9	60.3	57.9	55.6	53.4	51.2	49.2	47.2	45.3

NOTES: For Canadian high altitude (2,000 - 4,500'), reduce gas manifold pressure to 3.0" W.C. for natural gas and 9" W.C. for LP gas. (Includes 4% Input Reduction for Each 1,000 Feet). These specs do not apply to oil furnace installations. Reference Sources: ANSI Z233.1 & NFPA 54, National Fuel Gas Code.

Table 11. Equivalent Orifice Sizes for High Altitude Installations

M1/M5*B Models and for use with Blower Kit No. 903773 1/4 Hp 3 Speed

Furnace Input	Heating Speed Setting	Cooling Speed/ Evap Coil		
		2 Ton	2-1/2 Ton	3 Ton
086, 090	H	L	M	H
066, 070, 077	M	L	M	H
56	L	L	M	H

M1/M5*C Models and for use with Blower Kit No. 903413 1/2 Hp 4 Speed

Furnace Input	Heating Speed Setting	Cooling Speed/ Evap Coil			
		2 Ton	2-1/2 Ton & 3 Ton	3-1/2 Ton	4 Ton
077, 086, 090	ML	L	ML	MH	H
056, 066, 070	L	L	ML	MH	H

M1/M5*D Models & for use with Blower Kit No. 903890 3/4 Hp 4 Speed

Furnace Input	Heating Speed Setting	Cooling Speed/ Evap Coil			
		2 Ton	2-1/2 Ton & 3 Ton	3-1/2 Ton & 4 Ton	5 Ton
077, 086, 090	ML	L	ML	MH	H
056, 066, 070	L	L	ML	MH	H

Table 12. A/C Blower Speed Selection Chart

GAS INFORMATION

GAS FLOW RATES			
TIME FOR ONE REVOLUTION (SECONDS)	CUBIC FEET PER REVOLUTION OF GAS METER		
	1	5	10
10	360	1,800	3,600
12	300	1,500	3,000
14	257	1,286	2,571
16	225	1,125	2,250
18	200	1,000	2,000
20	180	900	1,800
22	164	818	1,636
24	150	750	1,500
26	138	692	1,385
28	129	643	1,286
30	120	600	1,200
32	113	563	1,125
34	106	529	1,059
36	100	500	1,000
38	95	474	947
40	90	450	900
42	86	429	857
44	82	409	818
46	78	391	783
48	75	375	750
50	72	360	720
52	69	346	692
54	67	333	667
56	64	321	643
58	62	310	621
60	60	300	600
62	58	290	581
64	56	281	563

GAS FLOW RATES			
TIME FOR ONE REVOLUTION (SECONDS)	CUBIC FEET PER REVOLUTION OF GAS METER		
	1	5	10
66	55	273	545
68	53	265	529
70	51	257	514
72	50	250	500
74	49	243	486
76	47	237	474
78	46	231	462
80	45	225	450
82	44	220	439
84	43	214	429
86	42	209	419
88	41	205	409
90	40	200	400
92	39	196	391
94	38	191	383
96	38	188	375
98	37	184	367
100	36	180	360
102	35	176	353
104	35	173	346
106	34	170	340
108	33	167	333
110	33	164	327
112	32	161	321
114	32	158	316
116	31	155	310
118	31	153	305
120	30	150	300

Table 13. Gas Flow Rates (Cubic Feet per Hour)

CAPACITY OF BLACK IRON GAS PIPE (CU. FT. PER HOUR) FOR NATURAL GAS (SPECIFIC GRAVITY - 0.60)								
NOMINAL BLACK IRON PIPE DIAMETER (IN.)	LENGTH OF PIPE RUN (FT)							
	10	20	30	40	50	60	70	80
½	130	90	75	65	55	50	45	40
¾	280	190	150	130	115	105	95	90
1	520	350	285	245	215	195	180	170
1 ¼	1,050	730	590	500	440	400	370	350
1 ½	1,600	1,100	890	760	670	610		

$$\text{Cubic Feet Per Hour Required} = \frac{\text{Input To Furnace (Btu/hr)}}{\text{Heating Value of Gas (Btu/Cu. Ft.)}}$$

NOTE: The cubic feet per hour listed in the table above must be greater than the cubic feet per hour of gas flow required by the furnace. To determine the cubic feet per hour of gas flow required by the furnace, divide the input rate of the furnace by the heating value (from gas supplier) of the gas.

**Table 14. Capacity of Black Iron Gas Pipe (cu. ft. per hour)
for Natural Gas w/ Specific Gravity = 0.60**

Figure 40. Gas Atmospheric Furnace, M1GH 056, 070 Models

WIRING DIAGRAM

Gas Atmospheric Furnaces, M1GH 056, 070

NOTES

1. Incoming power must be polarized. Observe color coding. (See furnace data label for electrical information.)
2. If any of the original wires (as supplied with the appliance) must be replaced, use 105°C Thermoplastic type wire or its equivalent.

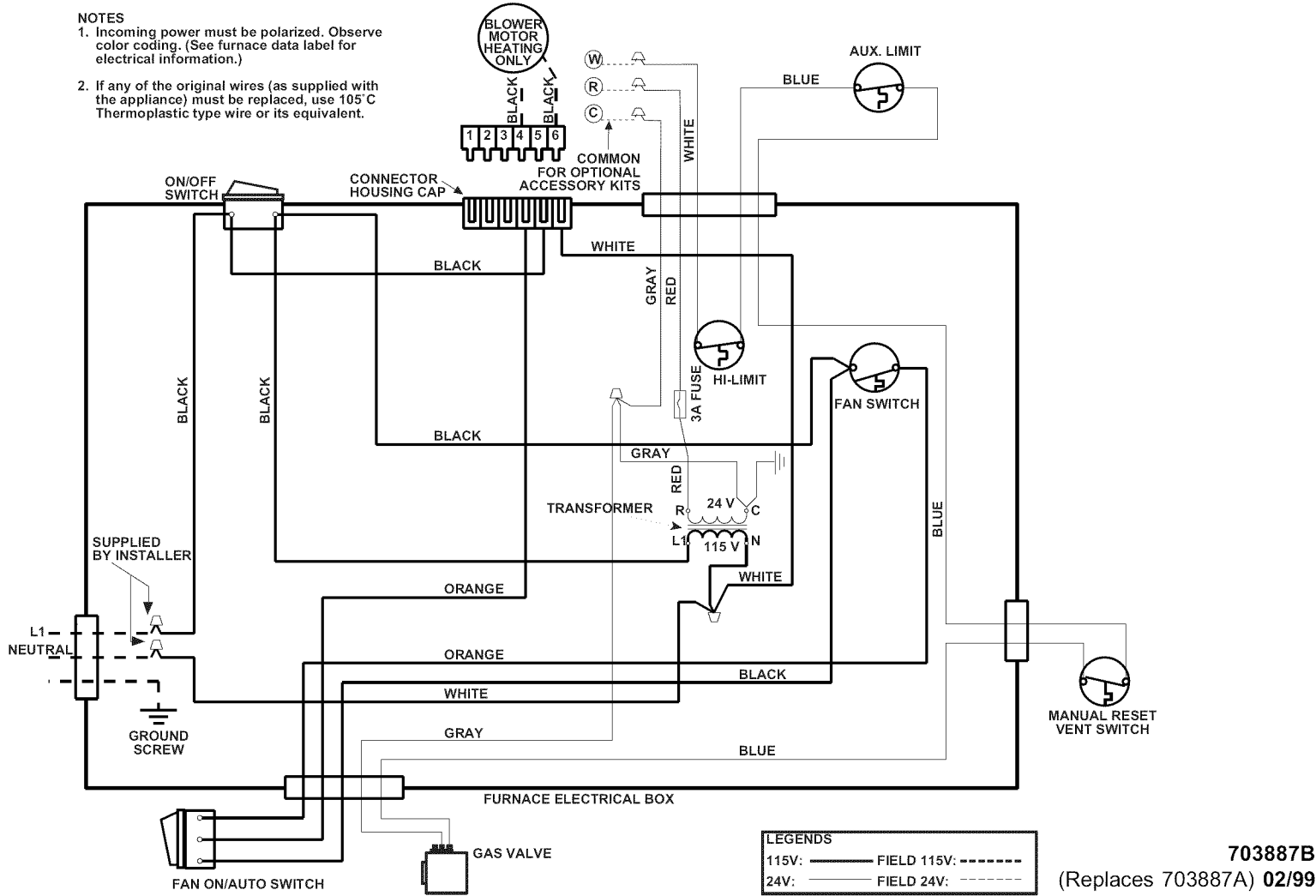

WIRING DIAGRAMS

WIRING DIAGRAM

Standing Pilot With Induced Draft Furnaces, M1GH 077, 090 Models.

NOTES

1. Incoming power must be polarized. Observe color coding. (See furnace data label for electrical information.)
2. If any of the original wires (as supplied with the appliance) must be replaced, use 105°C Thermoplastic type wire or its equivalent.

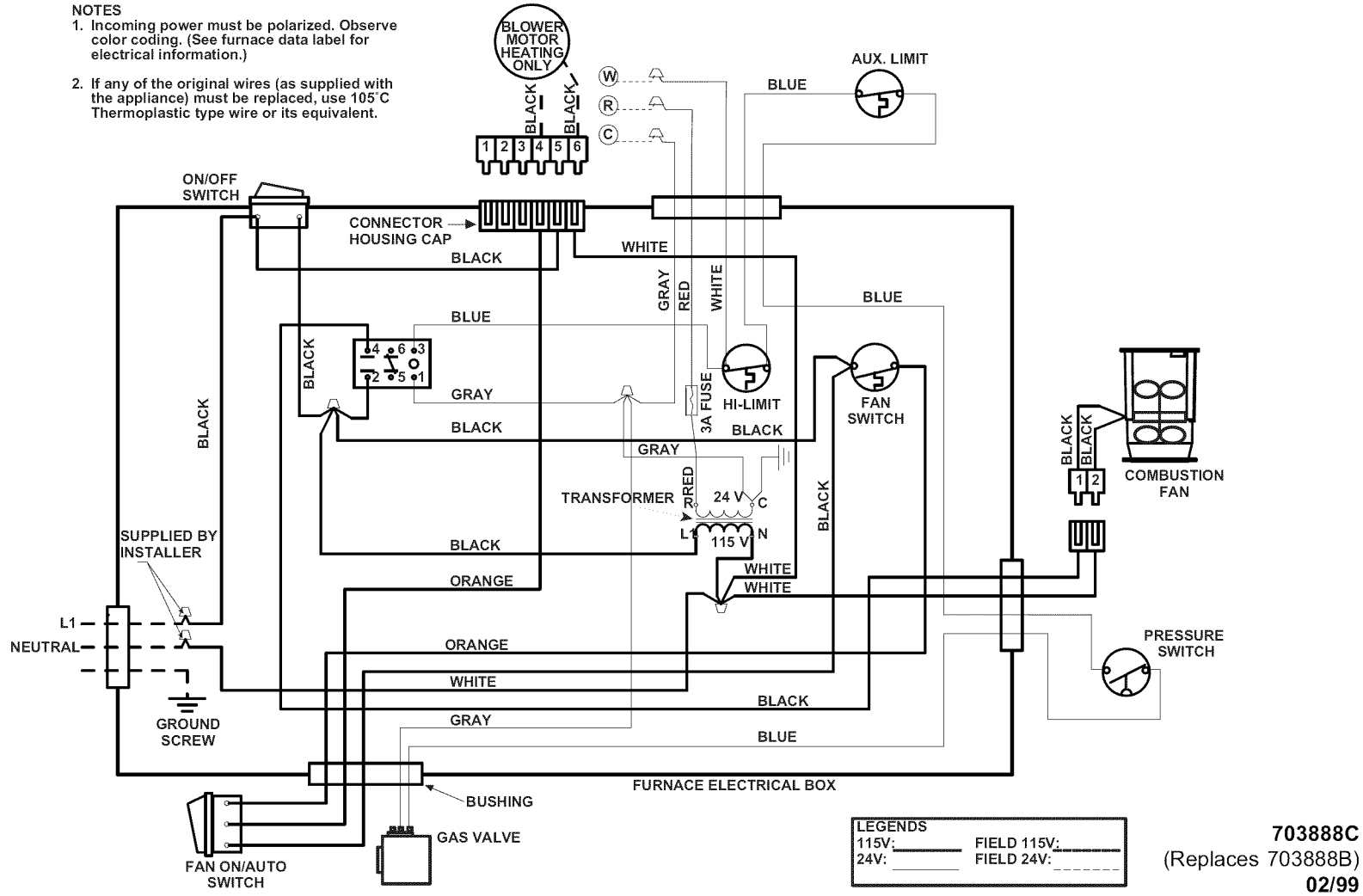

LEGENDS	
115V: _____	FIELD 115V: _____
24V: _____	FIELD 24V: _____

703888C
 (Replaces 703888B)
02/99

Figure 41. Standing Pilot with Induced Draft Furnace, M1GH 077, 090 Models

Figure 42. Gas Atmospheric Furnace, A/C Ready, M1GB 056, 070 Models

WIRING DIAGRAM

Gas Atmospheric Furnaces, A/C Ready, M1G (B, C, D) 056, 070 Models

NOTES

- Incoming power must be polarized. Observe color coding. (See furnace data label for electrical information.)
- If any of the original wires (as supplied with the appliance) must be replaced, use 105°C Thermoplastic type wire or its equivalent.

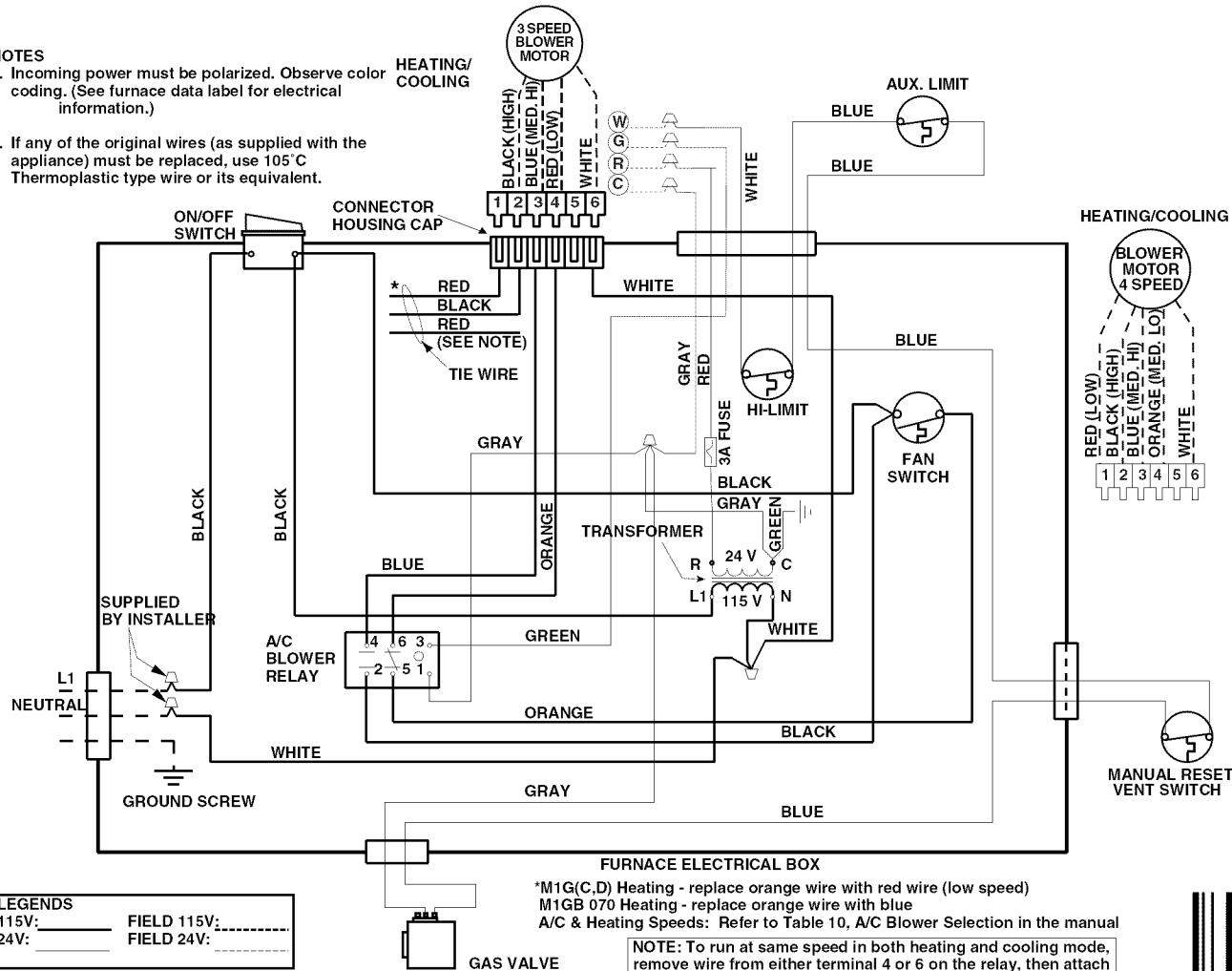

7101500 8/00
(Replaces 7101030)



WIRING DIAGRAM

Standing Pilot With Induced Draft Furnaces, A/C Ready , M1G(B,C,D) 077, 090 Models.

NOTES

- Incoming power must be polarized. Observe color coding. (See furnace data label for electrical information.)
- If any of the original wires (as supplied with the appliance) must be replaced, use 105°C Thermoplastic type wire or its equivalent.

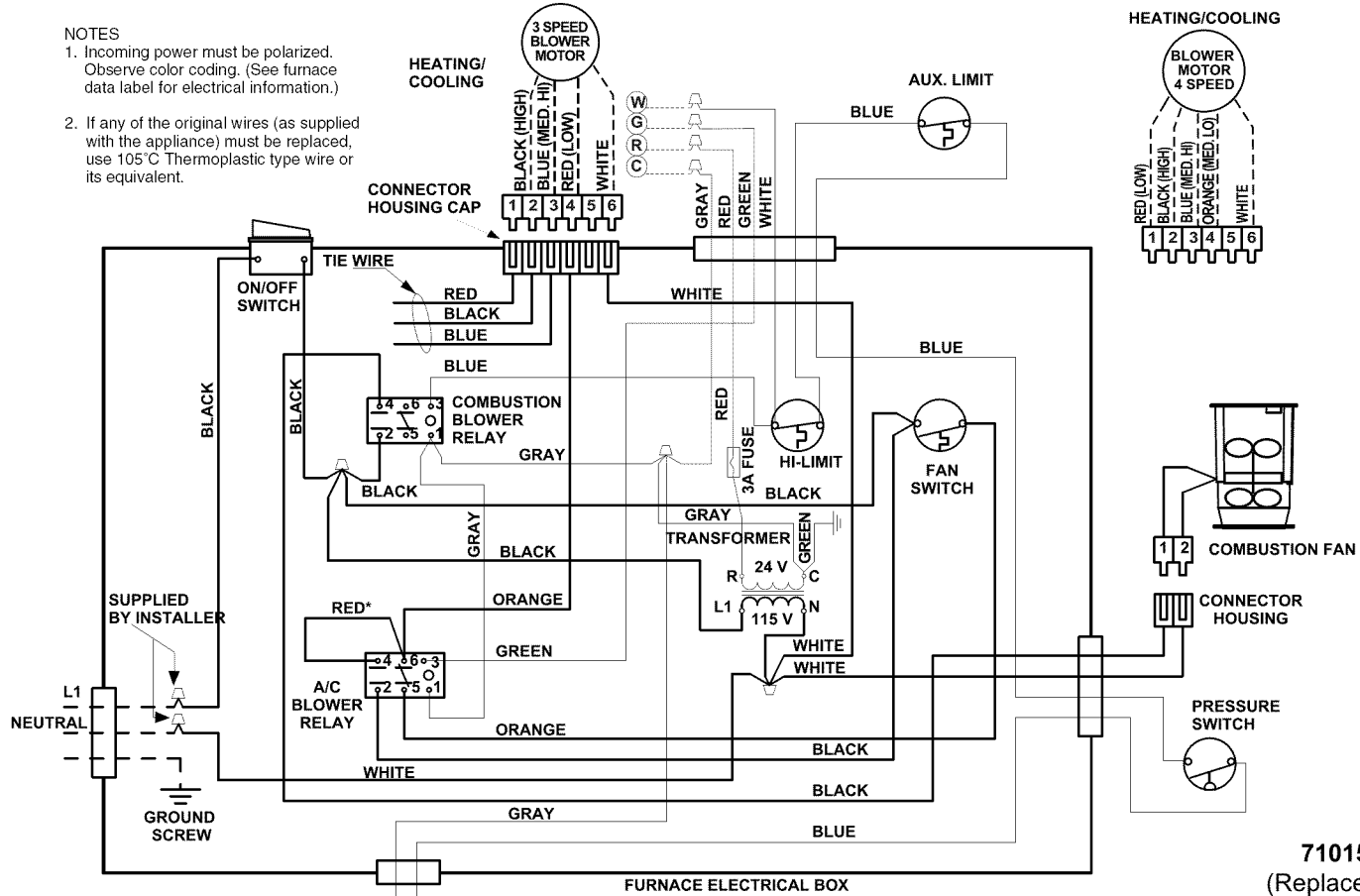

LEGENDS	
115V: _____	FIELD 115V: _____
24V: _____	FIELD 24V: _____

- * Jumper Wire - M1GB 090 Units Only
Otherwise Hi-Speed Connected to Blower Relay (Black)
- M1GB 077 Heating: Orange wire replaced by Blue
- M1GB 090 Heating: Orange wire replaced by Black

A/C & Heating Speeds: Refer to Table 10, A/C Blower Selection in the manual

7101510 08/00
(Replaces 7101040)



Figure 43. Standing Pilot with Induced Draft Furnace, A/C Ready M1G (B, C, D) 077, 090 Models

Figure 44. Gas Direct Ignition Furnace, Heating & A/C Ready - All M1M Models

WIRING DIAGRAM

Gas Direct Ignition Furnace, Heating & A/C Ready, M1M All Models.

NOTES

1. Incoming power must be polarized. Observe color coding. (See furnace data label for electrical information.)
2. If any of the original wires (as supplied with the appliance) must be replaced, use 105°C Thermoplastic type wire or its equivalent.

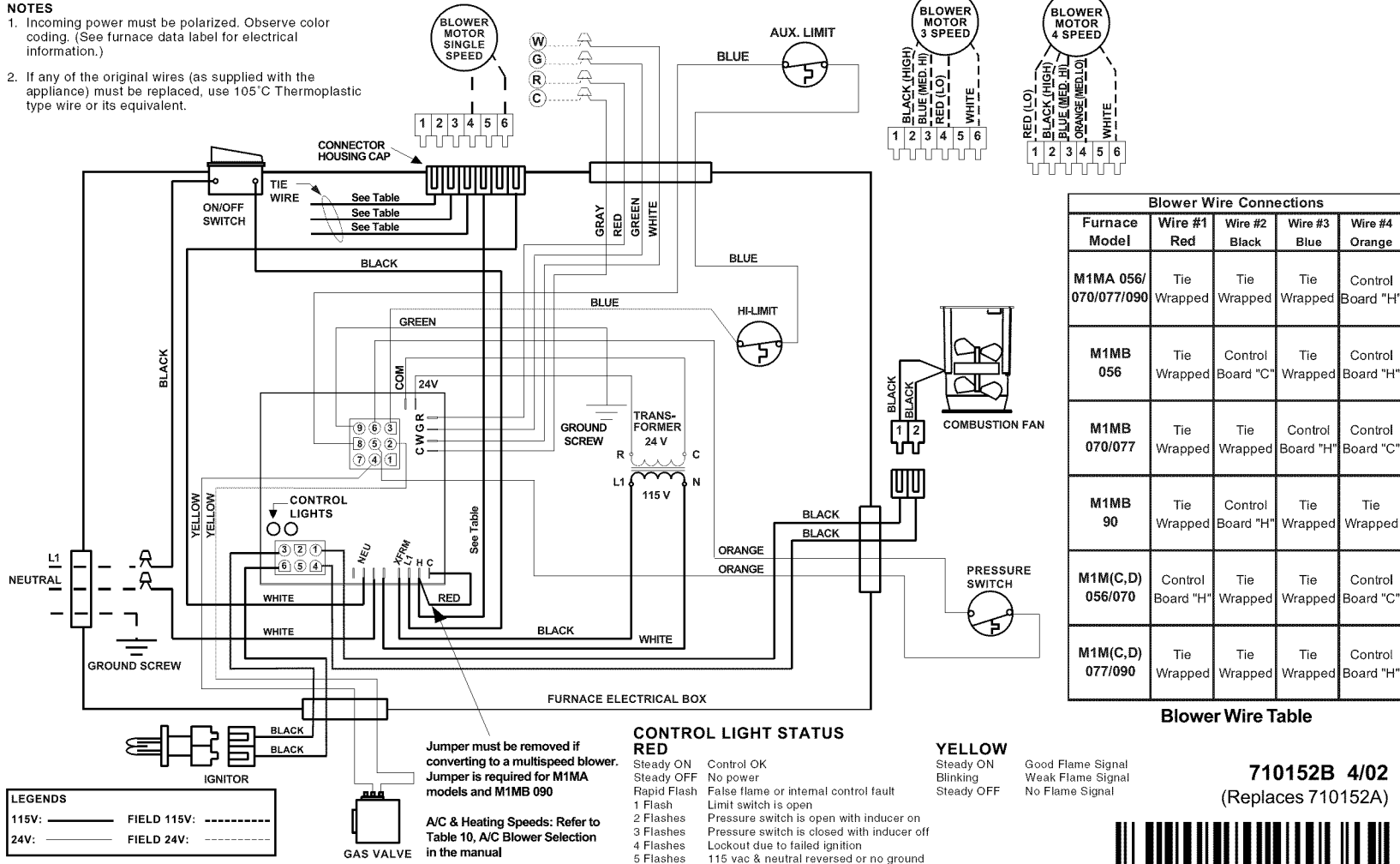

Blower Wire Connections				
Furnace Model	Wire #1 Red	Wire #2 Black	Wire #3 Blue	Wire #4 Orange
M1MA 056/070/077/090	Tie Wrapped	Tie Wrapped	Tie Wrapped	Control Board "H"
M1MB 056	Tie Wrapped	Control Board "C"	Tie Wrapped	Control Board "H"
M1MB 070/077	Tie Wrapped	Tie Wrapped	Control Board "H"	Control Board "C"
M1MB 90	Tie Wrapped	Control Board "H"	Tie Wrapped	Tie Wrapped
M1M(C,D) 056/070	Control Board "H"	Tie Wrapped	Tie Wrapped	Control Board "C"
M1M(C,D) 077/090	Tie Wrapped	Tie Wrapped	Tie Wrapped	Control Board "H"

Blower Wire Table

710152B 4/02
(Replaces 710152A)



LEGENDS

115V: ———	FIELD 115V: - - - - -
24V: ———	FIELD 24V: - - - - -

Jumper must be removed if converting to a multispeed blower. Jumper is required for M1MA models and M1MB 090

A/C & Heating Speeds: Refer to Table 10, A/C Blower Selection in the manual

CONTROL LIGHT STATUS

- RED**
- Steady ON Control OK
 - Steady OFF No power
 - Rapid Flash False flame or internal control fault
 - 1 Flash Limit switch is open
 - 2 Flashes Pressure switch is open with inducer on
 - 3 Flashes Pressure switch is closed with inducer off
 - 4 Flashes Lockout due to failed ignition
 - 5 Flashes 115 vac & neutral reversed or no ground

- YELLOW**
- Steady ON Good Flame Signal
 - Blinking Weak Flame Signal
 - Steady OFF No Flame Signal

WIRING DIAGRAM

M1B & M5S Furnace Series

120 Volt

Single Phase / 60 Hz

NOTES:

1. Incoming power must be polarized. Observe color coding. (See furnace data label for electrical information.)
2. If any of the original wires (as supplied with the appliance) must be replaced, use 105°C Thermoplastic type wire or its equivalent.
3. On models M1(B,S)A and M1(B,S)086 jumper wire is installed. On all other models, cooling speed is connected to black wire.
4. A/C Heating Speeds: Refer to Table 11, A/C Blower Selection
5. If any of the original wire supplied with the appliance is replaced, use 105°C wire or equivalent.
6. Use copper conductors only.

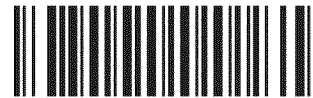
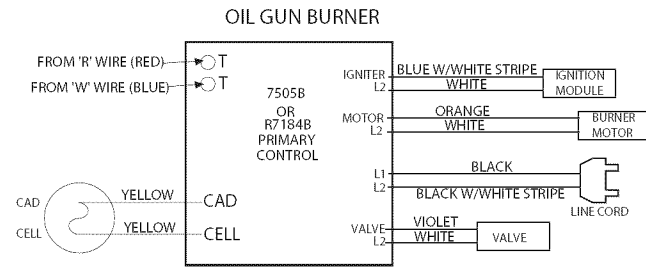
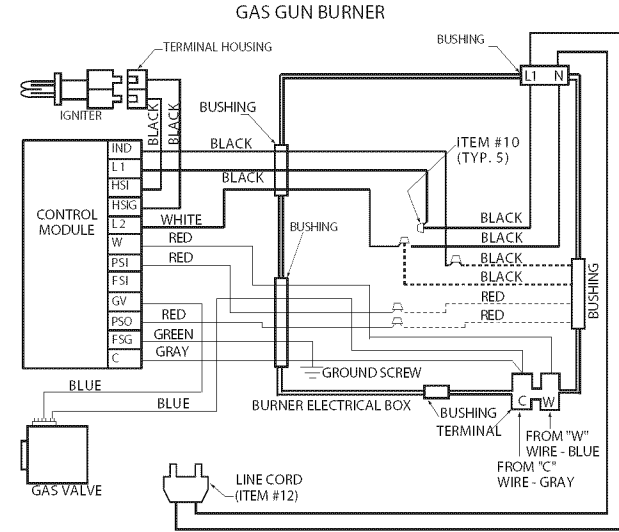
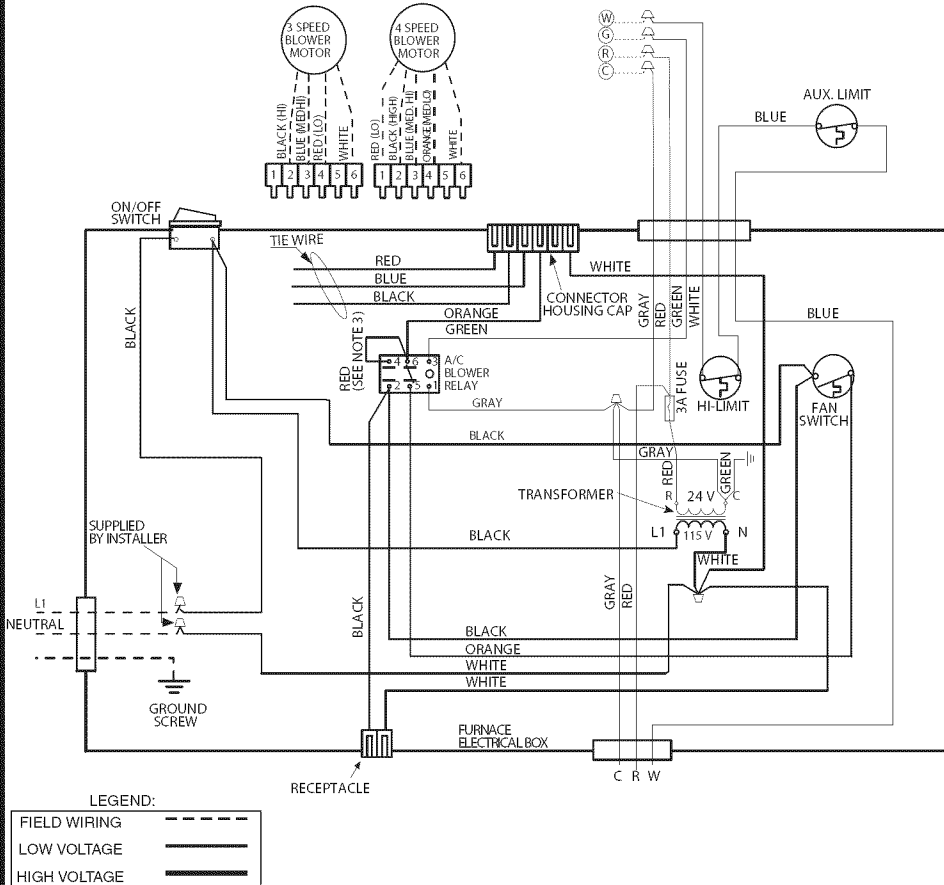

7109990
(Replaces 710971A)

0909

Figure 45. Gas and Oil Furnaces, A/C Ready - M1B & M5S (066, 086) Models

INSTALLATION / PERFORMANCE CHECK LIST

INSTALLER NAME:		
CITY _____	STATE _____	
INSTALLATION ADDRESS:		
CITY _____	STATE _____	
UNIT MODEL # _____		
UNIT SERIAL # _____		
Minimum clearances per Table 1 (page 5)?	YES	NO
Has the owner's information been reviewed with the home-owner?	YES	NO
Has the literature package been left near the furnace?	YES	NO

ELECTRICAL SYSTEM:		
Electrical connections tight?	YES	NO
Line voltage polarity correct?	YES	NO
Supply Voltage: _____ VOLTS		
Has the thermostat been calibrated?	YES	NO
Is the thermostat level?	YES	NO
Is the heat anticipator setting correct?	YES	NO

GAS SYSTEM:		
Gas Type: (circle one)	Natural Gas	Propane
Gas pipe connections leak tested?	YES	NO
Gas Line Pressure: _____ (in - W.C.)		
Is there adequate fresh air supply for combustion and ventilation?	YES	NO
Installation Altitude: _____ (FT.)		
Deration Percentage: _____ (%)		
Furnace Input: _____ (Btuh)		
Supply Air Temperature: _____ (°F)		
Return Air Temperature: _____ (°F)		
Temperature Rise: _____ (°F)		



We Encourage Professionalism



Through Technician Certification by NATE

VENTING SYSTEM:		
Vent free from restrictions?	YES	NO
Filter(s) secured in place?	YES	NO
Filter(s) clean?	YES	NO
Flue connections tight?	YES	NO
Is there proper draft?	YES	NO

NORDDYNE
COMPLETE COMFORT. GENUINE VALUE.

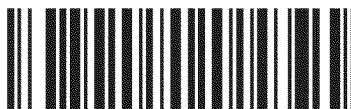

O'Fallon MO

709123A

709123A (Replaces 7091230)
Specifications & illustrations
subject to change without
notice or incurring obligations.
Printed in U.S.A. (04/10)