

# *Cub Cadet*<sup>®</sup>

# OPERATOR'S MANUAL

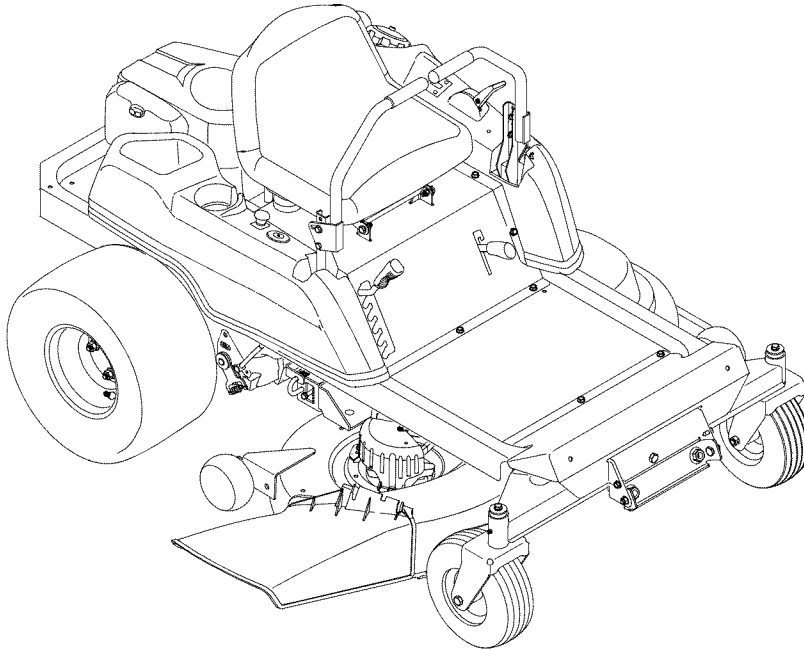

## **RZT SERIES TRACTOR Model Number RZT 42 w/42" Mower Deck**

### **IMPORTANT: READ SAFETY RULES AND INSTRUCTIONS CAREFULLY**

**Warning:** This unit is equipped with an internal combustion engine and should not be used on or near any unimproved forest-covered, brush-covered or grass-covered land unless the engine's exhaust system is equipped with a spark arrester meeting applicable local or state laws (if any). If a spark arrester is used, it should be maintained in effective working order by the operator. In the State of California the above is required by law (Section 4442 of the California Public Resources Code). Other states may have similar laws. Federal laws apply on federal lands. A spark arrester for the muffler is available through your nearest engine authorized service dealer or contact the service department, P.O. Box 361131 Cleveland, Ohio 44136-0019.

**CUB CADET LLC P.O. BOX 361131 CLEVELAND, OHIO 44136-0019 [www.cubcadet.com]**

---

## TABLE OF CONTENTS

TRACTOR PREPARATION .....	2
IMPORTANT SAFE OPERATION PRACTICES .....	4
SAFETY DECALS AND LABELS .....	7
SLOPE GAUGE .....	8
TO THE OWNER .....	9
CALLING SERVICE INFORMATION .....	9
RECORDING MODEL AND SERIAL NUMBER INFORMATION .....	9
SECTION 1: CONTROLS AND FEATURES .....	10
SECTION 2: OPERATION .....	13
SECTION 3: ADJUSTMENTS .....	20
SECTION 4: MAINTENANCE .....	21
SECTION 5: MOWER DECK .....	28
WARRANTIES .....	34

---

## TRACTOR PREPARATION

Remove the upper crating material from the shipping pallet, and cut any bands or tie straps securing the tractor to the pallet.

Use the lift handle to raise the deck to its highest position; engage the transmission bypass rods (Refer to SECTION 1, CONTROLS AND FEATURES); and carefully roll the tractor off the shipping pallet. Disengage the bypass rods.

Remove the deck wash system nozzle adapter and oil drain tube from the manual bag and store for future use.

### INSTALL OPERATOR'S SEAT

The operator's seat was partially inserted into the seat pivot bracket for shipping purposes. To install the seat proceed as follows:

1. Cut any straps securing the seat assembly and the drive control levers to the tractor. Remove any packing material.

**NOTE:** *The seat is partially inserted into the slots of the seat pivot bracket. If the seat does not become disengaged from the pivot bracket when removing the packaging material, the pivot bracket may be pivoted upward and the seat pushed into place as described in step 6. If the seat does disengage the pivot bracket, install the seat as instructed in steps 2 through 6.*

2. Pivot the seat pivot bracket partially upward. Refer to Figure 1.
3. Note the grooves in the seat adjust spacers attached to the bottom of the seat, then lift the seat and position above and to the rear of the pivot bracket.

4. Align the grooves in the seat adjust spacers with the sides of the adjustment slots in the pivot bracket.
5. Slide the seat adjust spacers into the slots of the pivot bracket.
6. Continue to push the seat forward in the pivot bracket until the front/left shoulder bolt of the seat assembly passes forward of the stop bracket on the seat pivot bracket. See Figure 1.

Use the seat adjust lever to adjust the seat position. Refer to "Adjusting the Operator's Seat" in Section 3 for seat adjustment instructions.

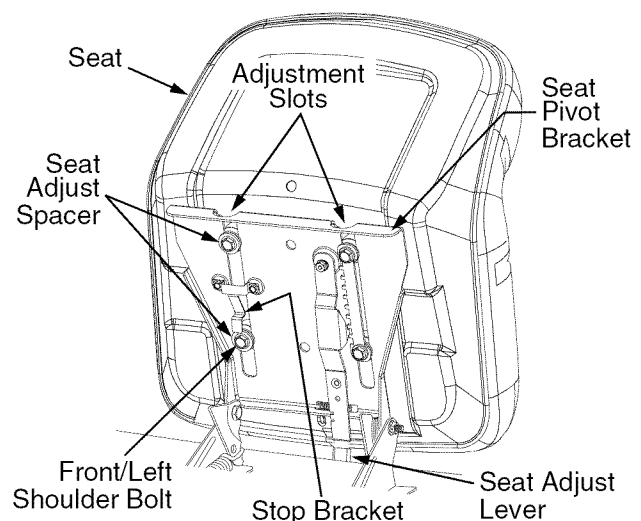

**Figure 1**

## POSITION DRIVE CONTROL LEVERS

The drive control levers of the tractor are lowered for shipping purposes. To accomplish this, the flange lock nut, hex screw, and flat washer normally used to secure each control lever to its pivot bracket are removed. The hardware is then installed in the slotted hole of each control lever for shipment. The control levers must be moved to their operating position. To reposition the control levers for operation, proceed as follows:

- Remove the hex screw, flat washer, and flange lock nut from the slot of one of the drive control levers.
- Lift and swing that control lever upward until the slotted hole in the lever bracket aligns with one of the holes in the pivot bracket. Refer to Figure 2.
- Slide the flat washer onto the hex screw. **From the outside**, insert the hex screw w/washer through the control lever slot and the hole of the pivot bracket. Secure with the flange lock nut. See Figure 2.

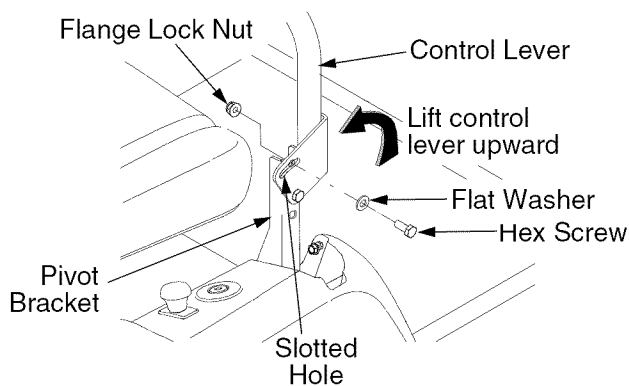

Figure 2

- Note the relative position of the control lever to the pivot bracket, then repeat the previous steps to reposition the other control lever in approximately the same position.
- Refer to "Adjusting the Drive Control Levers" in Section 3 for instructions on final adjustment of the levers.

## CONNECT THE BATTERY



**WARNING: Battery posts, terminals and related accessories contain lead and lead compounds. Wash hands after handling.**

The tractor is shipped with an activated sealed battery, with the positive battery cable factory connected. The negative cable must be connected.

**NOTE:** Make sure the ignition switch is in the "OFF" position before attaching the battery cable.

1. Pull the protective cap, if present, off the negative terminal of the battery, and remove the hex cap screw and nut from the free end of the negative battery cable.
2. Connect the negative battery cable (heavy black) to negative terminal (NEG) of the battery using the hex cap screw and nut. Slide the black terminal cover, if present, over the negative terminal of the battery.

## REMOVE THE CHUTE STOP

- Locate the chute stop on the right side of the mower, between discharge chute and cutting deck.
- While holding the discharge chute up, rotate the chute stop clockwise and remove.
- Discard the chute stop.

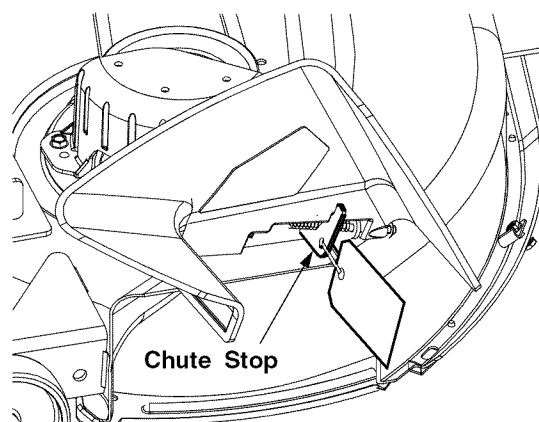

Figure 3



## WARNING

- The engine exhaust, some of its constituents, and certain vehicle components contain or emit chemicals known to the State of California to cause cancer, birth defects or other reproductive harm.
- This unit is equipped with an internal combustion engine and should not be used on or near any unimproved forest-covered, brush-covered, or grass-covered land unless the engine's exhaust system is equipped with a spark arrester meeting applicable local or state laws (if any). If a spark arrester is used, it should be maintained in effective working order by the operator.
- In the State of California, the above is required by law (Section 4442 of the California Public Resources Code). Other States may have similar laws. Federal laws apply to federal lands. A spark arrester muffler is available at your nearest engine authorized service center.

# IMPORTANT

## SAFE OPERATION PRACTICES



THIS SYMBOL POINTS OUT IMPORTANT SAFETY INSTRUCTIONS WHICH, IF NOT FOLLOWED, COULD ENDANGER THE PERSONAL SAFETY AND/OR PROPERTY OF YOURSELF AND OTHERS. READ AND FOLLOW ALL INSTRUCTIONS IN THIS MANUAL BEFORE ATTEMPTING TO OPERATE YOUR UNIT. FAILURE TO COMPLY WITH THESE INSTRUCTIONS MAY RESULT IN PERSONAL INJURY. WHEN YOU SEE THIS SYMBOL—  **HEED ITS WARNING.**



## DANGER

Your lawn mower was built to be operated according to the rules for safe operation in this manual. As with any type of power equipment, carelessness or error on the part of the operator can result in injury. This lawn mower is capable of amputating hands and feet or throwing objects. Failure to observe the following safety instructions could result in serious injury or death.



### I. GENERAL OPERATION

1. Read, understand and follow all instructions in the manual and on the machine before starting. Keep this manual in a safe place for future and regular reference.
2. Only allow responsible individuals familiar with the instructions to operate the machine. Know the controls and how to stop the machine quickly.
3. Do not put hands or feet under the cutting deck or near rotating parts.
4. Clear the area of objects such as rocks, toys, wire, etc. which could be picked up and thrown by the blades. A small object may have been overlooked and could be accidentally thrown by the mower in any direction and cause injury to you or a bystander. To help avoid a thrown objects injury, keep children, animals, bystanders and helpers at least 75 feet from the mower while it is in operation. Always wear safety glasses with side shields or safety goggles during operation or while performing an adjustment or repair, to protect eyes from foreign objects. Stop the blades when crossing gravel drives, walks or roads.
5. Be sure the area is clear of other people before mowing. Stop machine if anyone enters the area.
6. Never carry passengers.
7. Disengage the blades before shifting into reverse and backing up. Always look down and behind before and while backing.
8. Be aware of the mower and attachment discharge direction and do not point it at anyone. Do not operate the mower without either the entire grass catcher or the chute guard in place.
9. Slow down before turning. Operate the machine smoothly. Avoid erratic operation and excessive speed.
10. Never leave a running machine unattended. Always turn off the blades, place the transmission in neutral, set the parking brake, stop the engine and remove key before dismounting.
11. Turn off blades when not mowing.
12. Stop the engine and wait until the blades come to a complete stop before (a) removing the grass catcher or unclogging chute, or (b) making any repairs, adjusting or removing any grass or debris.

13. Mow only in daylight or good artificial light.
14. Do not operate the machine while under the influence of alcohol or drugs.
15. Watch for traffic when operating near or crossing roadways.
16. Use extra care when loading or unloading the machine into a trailer or truck. This unit should not be driven up or down a ramp onto a trailer or truck under power, because the unit could tip over causing serious personal injury. The unit must be pushed manually on a ramp to load or unload properly.
17. Never make a cutting height adjustment while the engine is running if the operator must dismount to do so.
18. Wear sturdy, rough-soled work shoes and close-fitting slacks and shirts. Do not wear loose fitting clothes or jewelry. They can be caught in moving parts. Never operate a unit in bare feet, sandals or sneakers.
19. Check overhead clearance carefully before driving under power lines, wires, bridges or low hanging tree branches, before entering or leaving buildings, or in any other situation where the operator may be struck or pulled from the unit, which could result in serious injury.
20. Disengage all attachment clutches, set the parking brake in the on position, and put the lap bars to the neutral or out position before attempting to start the engine.
21. Your mower is designed to cut normal residential grass of a height no more than 10". Do not attempt to mow through unusually tall, dry grass (e.g. pasture) or piles of dry leaves. Debris may build up on the mower deck or contact the engine exhaust presenting a potential fire hazard.
22. Use only accessories approved for this machine by *Cub Cadet*. Read, understand and follow all instructions provided with the approved accessory.

## II. SLOPE OPERATION

Slopes are a major factor related to loss of control and tip-over accidents, which can result in severe injury or death. **All** slopes require extra caution. If you cannot back up the slope or if you feel uneasy on it, do not mow it.

For your safety, use the slope gauge included as part of this manual to measure slopes before operating this unit on a sloped or hilly area. If the slope is greater than 15° as shown on the slope gauge, do not operate this unit on that area or serious injury could result.

## **DO:**

Mow across slopes, not up and down.

Keep all movement on the slopes **slow** and **gradual**. Do not make sudden changes in speed or direction. Rapid acceleration or deceleration could cause the front of the machine to lift and rapidly flip over backwards, which could cause serious injury.

Avoid starting or stopping on a slope. If the tires are unable to maintain traction, disengage the blades and proceed slowly and carefully **straight** down the slope. Do not mow the slope until able to maintain traction.

Use slow speed. Choose a low enough speed so that you will not have to stop while on the slope.

Remove obstacles such as rocks, limbs, etc.

Watch for holes, ruts or bumps. Uneven terrain could overturn the machine. **Tall grass can hide obstacles.**

Follow the manufacturer's recommendations for counterweights with attachments to improve stability.

Use extra care with grass catchers or other attachments. These can change the stability of the machine.

## **DO NOT:**

**Do not** turn on slopes unless necessary; then turn slowly and use extra care while turning.

**Do not** mow near drop-offs, ditches or embankments. The mower could suddenly turn over if a wheel is over the edge of a cliff or ditch, or if an edge caves in.

**Do not** mow on wet grass. Reduced traction could cause sliding.

**Do not** try to stabilize the machine by putting your foot on the ground.

**Do not** use the grass catcher on steep slopes.

## III. CHILDREN

Tragic accidents can occur if the operator is not alert to the presence of children. Children are often attracted to the machine and the mowing activity. **Never** assume that children will remain where you last saw them.

1. Keep children out of the mowing area and in watchful care of an adult other than the operator.
2. Be alert and turn the machine off if children enter the area.
3. Before and when backing up, look behind and **down** for small children.
4. Never carry children, even with the blades off. They may fall off and be seriously injured or may interfere with safe machine operation.

5. Never allow children under 14 years old to operate the machine. Children 14 years and over should only operate the machine under close parental supervision and proper instruction.
6. Use extra care when approaching blind corners, shrubs, trees or other objects that may obscure your vision of a child or other hazard.
7. Remove the key when the machine is left unattended to prevent unauthorized operation.



#### IV. SERVICE

1. Use extreme care in handling gasoline and other fuels. They are extremely flammable and the vapors are explosive.
  - a. Use only an approved container.
  - b. Never remove fuel cap or add fuel with the engine running. Allow the engine to cool at least two minutes before refueling.
  - c. Replace the fuel cap securely and wipe off any spilled fuel before starting the engine as it may cause a fire or explosion.
  - d. Extinguish all cigarettes, cigars, pipes and other sources of ignition.
  - e. Never refuel the machine indoors because fuel vapors will accumulate in the area.
  - f. Never store the fuel container or machine inside where there is an open flame or spark, such as a gas hot water heater, space heater or furnace.
2. Never run a machine inside a closed area.
3. To reduce fire hazard, keep the machine free of grass, leaves or other debris build-up. Clean up oil or fuel spillage. Allow the machine to cool at least 5 minutes before storing.
4. Before cleaning, repairing or inspecting, make certain the blade and all moving parts have stopped. Disconnect the spark plug wire, and keep the wire away from the spark plug to prevent accidental starting.
5. Check the blade and engine mounting bolts at frequent intervals for proper tightness. Also visually inspect blades for damage (e.g., excessive wear, bent, cracked). Replace with blades which meet original equipment specifications.
6. Keep all nuts, bolts and screws tight to be sure the equipment is in safe working condition.
7. Never tamper with safety devices. Check their proper operation regularly. Use all guards as instructed in this manual.
8. After striking a foreign object, stop the engine, remove the wire from the spark plug and thoroughly inspect the mower for any damage. Repair the damage before restarting and operating the mower.
9. Grass catcher components are subject to wear, damage and deterioration, which could expose moving parts or allow objects to be thrown. For your safety protection, frequently check the components and replace with manufacturer's recommended parts when necessary.
10. Mower blades are sharp and can cut. Wrap the blades or wear gloves, and use extra caution when servicing blades.
11. Check the park brake operation frequently. Adjust and service as required.
12. Muffler, engine and belt guards become hot during operation and can cause a burn. Allow to cool down before touching.
13. Do not change the engine governor settings or overspeed the engine. Excessive engine speeds are dangerous.
14. Observe proper disposal laws and regulations. Improper disposal of fluids and materials can harm the environment and the ecology.
  - a. Prior to disposal, contact your local Environmental Protection Agency to determine the proper method for disposing of the waste. Recycling centers are established to properly dispose of materials in an environmentally safe fashion.
  - b. Use proper containers when draining fluids. Do not use food or beverage containers that may mislead someone into drinking from them. Properly dispose of the containers immediately following the draining of fluids.
  - c. DO NOT pour oil or other fluids into the ground, down a drain or into a stream, pond, lake, or other body of water. Observe Environmental Protection Agency regulations when disposing of oil, fuel, coolant, brake fluid, filters, batteries, tires and other harmful waste.
15. With the exception of utilizing the deck wash feature, we do not recommend the use of a pressure washer or garden hose to clean your tractor. Water may cause damage to electrical components; pulleys; bearings; or the engine. The use of water will result in shortened life and reduce serviceability.



**WARNING - YOUR RESPONSIBILITY:** Restrict the use of this power machine to persons who read, understand and follow the warnings and instructions in this manual and on the machine.

# SAFETY DECALS AND LABELS

Keep product safety graphics (decals) clean. Replace any safety graphic that is damaged, destroyed, missing, painted over or can no longer be read. Replacement safety graphics are available through your dealer.

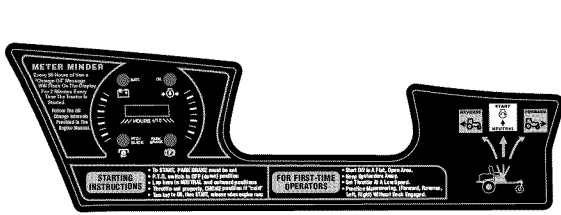

**GENERAL SAFETY INSTRUCTIONS**  
 – LOCATED ON LEFT CONSOLE  
 ASIDE OPERATOR'S SEAT

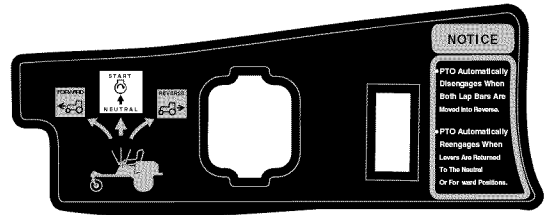

**GENERAL OPERATING INSTRUCTIONS**  
 – LOCATED ON RIGHT CONSOLE  
 ASIDE OPERATOR'S SEAT



**GENERAL SAFETY INSTRUCTIONS**  
**WARNING** – LOCATED IN CENTER  
 OF SEAT BOX FRAME



**DECK HEIGHT**  
**INDICATOR**

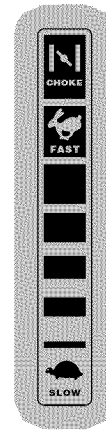

**THROTTLE CONTROL**  
**INDICATOR**



**PARK BRAKE**  
**INDICATOR**



**HANDS AND FEET**  
**SAFETY GRAPHIC**



**MOWER DECK**  
**SAFETY GRAPHIC**



**MOWER DECK**  
**SAFETY GRAPHIC**

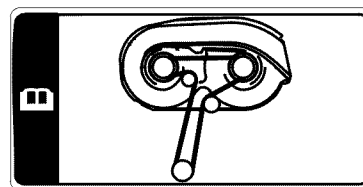

**MOWER DECK**  
**INFORMATION GRAPHIC**

USE THIS PAGE AS A GUIDE TO DETERMINE SLOPES WHERE YOU MAY NOT OPERATE SAFELY.

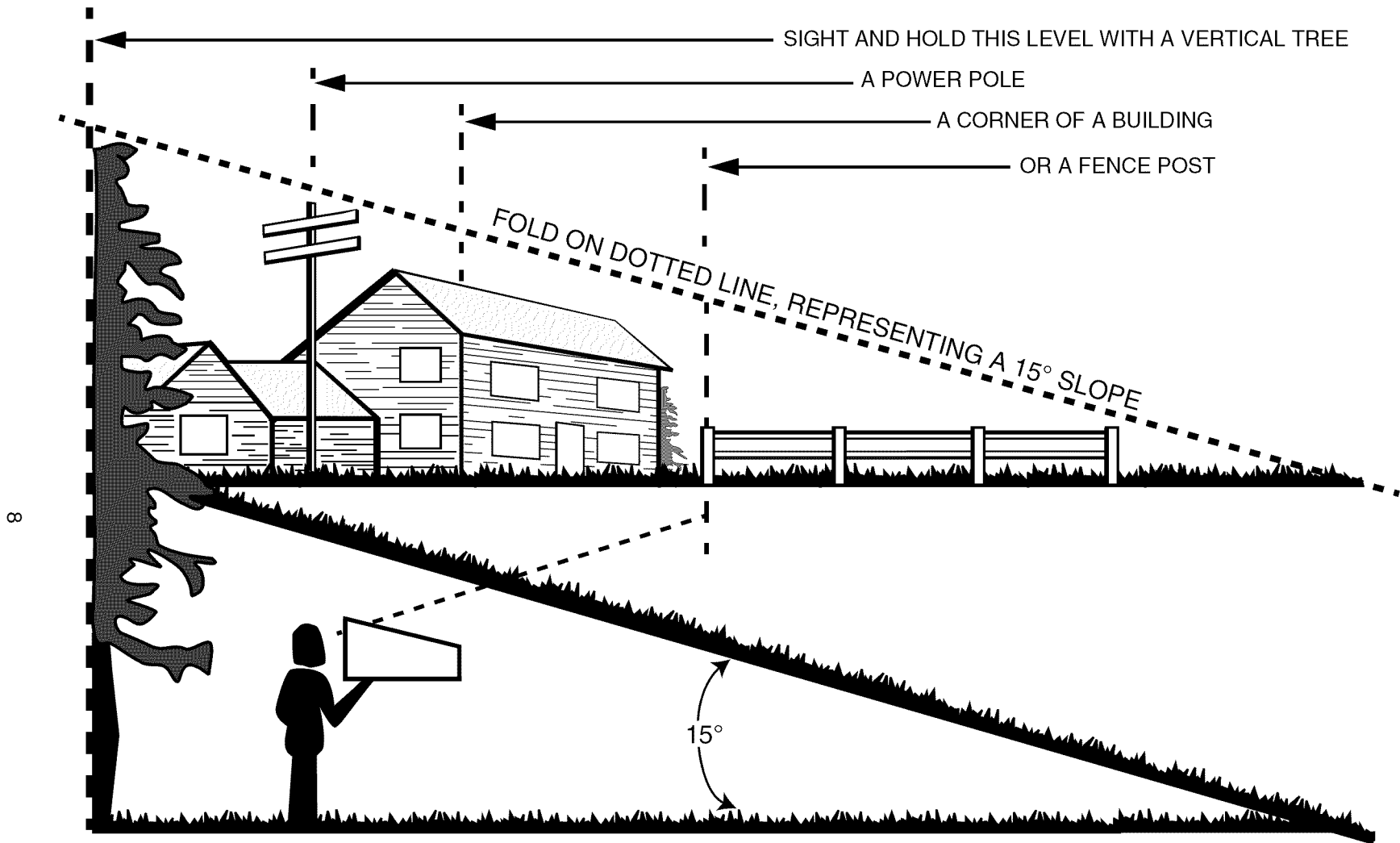

(Keep this sheet in a safe place for future reference.)

# SLOPE GAUGE



**WARNING**

Do not mow on inclines with a slope in excess of 15 degrees (a rise of approximately 2-1/2 feet every 10 feet). A riding mower could overturn and cause serious injury. If operating a walk-behind mower on such a slope, it is extremely difficult to maintain your footing and you could slip, resulting in serious injury. Operate RZT zero turn tractors across the face of slopes rather than up and down. Begin with the first pass across the bottom of the slope and turn uphill at the end of each pass whenever possible.



---

## TO THE OWNER

This Operator's Manual is an important part of your new tractor. The information contained in this manual has been prepared in detail to help you better understand the features, correct operation, adjustments, and maintenance of your tractor. The performance and dependability of this tractor rely greatly on the manner in which it is operated and maintained. Therefore, it is recommended that all operators of the tractor carefully read this manual and fully understand its operation. Also keep the manual available for reference to ensure proper operation, and that maintenance procedures are performed as scheduled to assure the tractor's optimal mechanical condition.

**NOTE:** All references to *LEFT, RIGHT, FRONT, and REAR*, unless specifically stated otherwise, indicate that relative position on the tractor when facing forward while seated in the operator's seat.

**CAUTION:** DO NOT tow your Model RZT42 tractor. Towing may damage the transmissions. Place the tractor on a LEVEL SURFACE before pulling the transmission bypass rods to the engaged position (transmission disengaged).

Your local authorized *Cub Cadet* dealer is interested in the performance you receive from your tractor, and with the maintenance needed to ensure the satisfactory operation of your tractor. The dealer has trained service personnel familiar with the latest servicing information, is equipped with the latest tools, and has a complete line of genuine *Cub Cadet* service parts which assure proper fit and high quality.

---

## CALLING SERVICE INFORMATION

The engine manufacturer is responsible for all engine-related issues with regards to performance, power-rating, and specifications.

If you have difficulties with the tractor and/or equipment; have any questions regarding the operation or maintenance of this equipment; or desire additional information not found in this manual, contact your nearest authorized *Cub Cadet* dealer. If you need assistance in locating a dealer in your area, contact the Customer Dealer Referral Line by calling:

**1-877-282-8684**

Or you may contact Cub Cadet via the internet by logging on to our Web Site at:

**[www.cubcadet.com](http://www.cubcadet.com)**

To obtain top performance and assure economical operation, the tractor should be inspected by your authorized dealer periodically or at least once a year, depending on its hours of use. Before calling your dealer, make sure that you have your model number(s) and manufacturing date available for the dealer.

---

## RECORDING MODEL AND SERIAL NUMBER INFORMATION

Product identification plates are provided for major components of your tractor. The numbers on these plates are important if your tractor should require dealer service, or if you need additional information on your tractor. Prior to using your tractor for the first time, record the numbers from the identification plates in the appropriate spaces provided below.

The chassis model plate, showing the factory model number and Mfg. Date (See Figure 4) can be found either on the underside of the seat mounting base or on the right frame rail near the right front tire.

The engine information appear on a decal affixed to the engine shrouding (See Figure 5).

Model \_\_\_\_\_ Factory Model No. \_\_\_\_\_ Mfg. Date \_\_\_\_\_

Delivery Date \_\_\_\_\_ Engine Model/Spec No. \_\_\_\_\_ Engine Serial No. \_\_\_\_\_

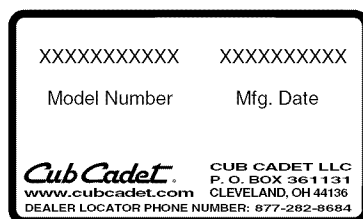

Figure 4

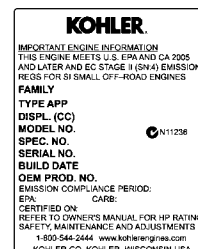
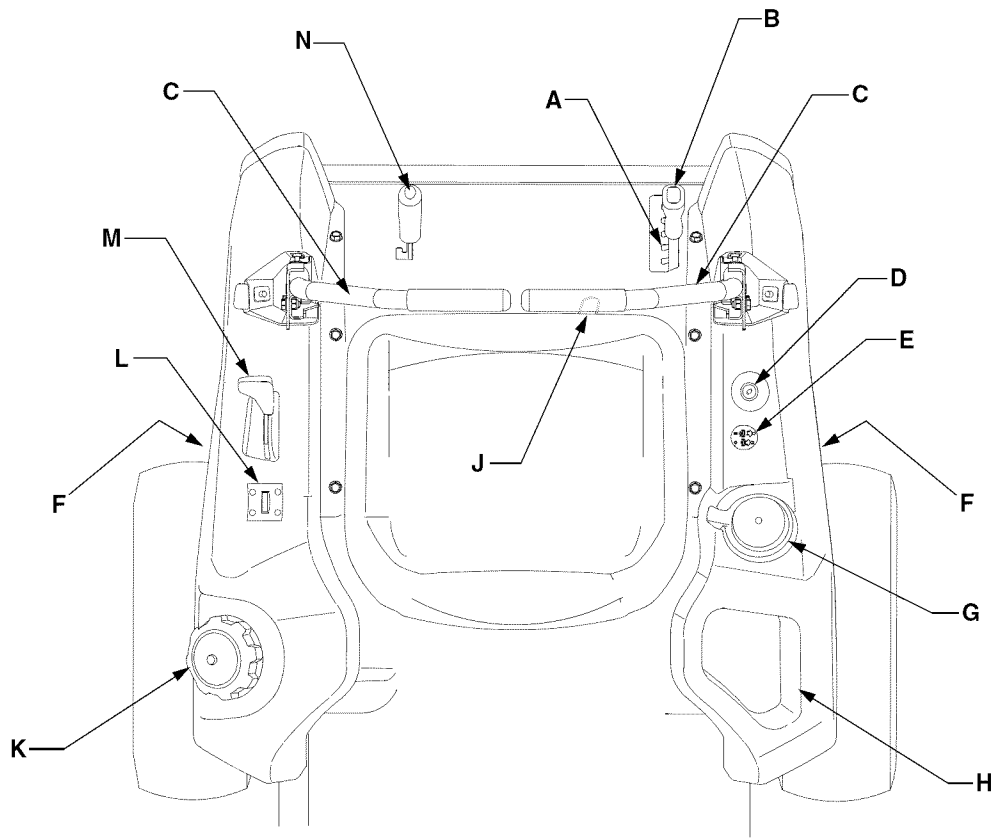

Figure 5

---

## SECTION 1: CONTROLS AND FEATURES



**Figure 6**

- |  |                                     |
|--|-------------------------------------|
| A. Deck Height Index                   | H. Storage Tray                     |
| B. Deck Lift Handle                    | J. Seat Adjustment Lever (Not Seen) |
| C. RH and LH Drive Control Levers      | K. Fuel Tank Cap                    |
| D. Ignition Switch                     | L. Hour Meter/Indicator Panel       |
| E. PTO Switch                          | M. Throttle Control                 |
| F. Transmission Bypass Rod (Not Shown) | N. Parking Brake Engagement Lever   |
| G. Cup Holder                          |                                     |

**NOTE:** References to *LEFT*, *RIGHT*, *FRONT*, and *REAR* indicate that position on the tractor when facing forward while seated in the operator's seat.

### A. Deck Height Index

The deck height index consists of six index notches located on the front/right of the seat box frame. Each notch corresponds to a 1/2 inch change in the deck height position ranging from 1-1/2 inches at the lowest notch to 4 inches at the highest notch.

### B. Deck Lift Handle

The deck lift handle is located on the front/right of the seat box frame, and is used to raise and lower the mower deck.

Pull the handle to the left out of the index notch and push downward to lower the deck, or pull upward to raise the deck. When the desired height is attained, move the lift handle to the right until fully in the index notch.

### C. RH and LH Drive Control Levers

The RH and LH control levers are located on each side of the operator's seat. These hinged levers pivot outward to open space to permit the operator to either sit in the tractor seat, or to dismount the tractor. The levers must be fully opened out and in the neutral position to start the tractor engine.

Each lever controls the respective RH or LH transmission. Consequently, these levers control all of the movements of the tractor. Driving and steering utilizing these control levers is quite different from conventional tractors, and will take some practice to master. Refer to **SECTION 2: OPERATION** for instructions on using the control levers.

### D. Ignition Switch

The ignition switch is located on the RH console to the right of the operator's seat.

The ignition switch has three positions as follow:

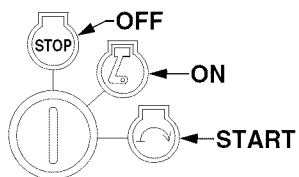

**Figure 7**

OFF - The engine and electrical system is turned off.

ON - The tractor electrical system is energized.

START- The starter motor will turn over the engine. Release the key immediately when the engine starts

**NOTE:** To prevent accidental starting and/or battery discharge, remove the key from the ignition switch when the tractor is not in use.

### E. Power Take-Off (PTO) Switch

The PTO switch is located on the RH console to the right of the operator's seat.

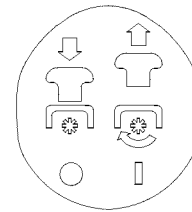

**Figure 8**

The PTO switch operates the electric PTO clutch mounted on the bottom of the engine crankshaft. Pull the switch knob upward to engage the PTO clutch, or push the knob downward to disengage the clutch.

The PTO switch must be in the "disengaged" position when starting the engine.

### F. Transmission Bypass Rods (Not Seen)

The transmission bypass rods (one for each the RH and LH transmission) are located beneath the frame platform, just inside each rear wheel.

When engaged, the two rods open a bypass within the hydrostatic transmissions, which allows the tractor to be pushed short distances by hand. Refer to **SECTION 4: MAINTENANCE** for instructions on using the bypass feature.



**WARNING:** Never tow your tractor. Towing the tractor with the rear wheels on the ground may cause severe damage to the transmissions.

### G. Cup Holder

The cup holder is located toward the rear of the RH console to the right of the operator's seat.

### H. Storage Tray

The storage tray is located at the rear of the RH console.

### J. Seat Adjustment Lever (Not Seen)

The seat adjustment lever is located below the front/left of the seat. The lever allows for adjustment of the fore to aft position of the operator's seat. Refer to **SECTION 3: ADJUSTMENTS** for instructions on adjusting the seat position.

### K. Fuel Tank Cap

The fuel tank cap is located at the rear of the LH console. Turn the cap counterclockwise to unscrew and remove from the fuel tank. Always re-install the fuel cap tightly onto the fuel tank after removing.



**WARNING:** Never fill the fuel tank when the engine is running. If the engine is hot from recently running, allow to cool for several minutes before refueling. Highly flammable gasoline could splash onto the engine and cause a fire.

## L. Hour Meter/Indicator Panel

The hour meter/indicator panel is located on the LH console to the left of the operator's seat.

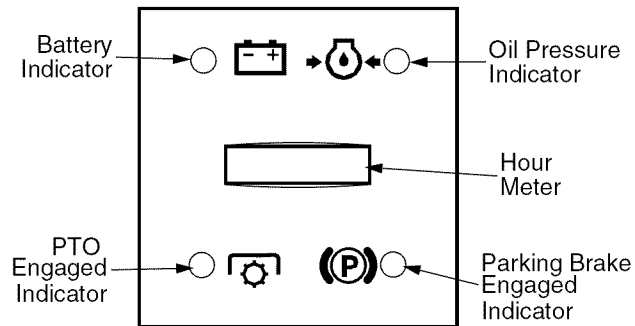

Figure 9

### Hour Meter Features

The hour meter records the hours that the tractor has been operated in the digital display (tenths of an hour-right most digit).

**NOTE:** The hour meter is activated whenever the ignition switch is turned to the "ON" position. Keep a record of the actual hours of operation to assure all maintenance procedures are completed according to the instructions in this manual and the engine manual.

- When key is turned to the "ON" position, the battery indicator light briefly illuminates and the battery voltage is briefly displayed. The display then changes to the accumulated hours.
- The Indicator Monitor will also remind the operator of maintenance intervals for changing the engine oil. The LCD will alternately flash, "CHG"; "OIL" and the recorded hours for five minutes after every 50 hours of recorded operation. The maintenance interval lasts for two hours (from 50-52, 100-102, 150-152, etc.). The LCD will flash as described for five minutes every time the tractor's engine is started during this maintenance interval. **Follow the oil change intervals provided in this manual.**

### Indicator Panel Features

#### Battery Indicator (Refer to Figure 9)

- Illuminates and the battery voltage is displayed briefly when the ignition switch is turned to the "ON" position.
- Illuminates to indicate the battery voltage has dropped below 11.5 (+0.5/-1.0) volts. The battery voltage is also displayed on the hour meter. If this indicator and display come on during operation,

check the battery and charging system for possible causes and/or contact your Cub Cadet dealer.

#### Oil Pressure Indicator (Refer to Figure 9)

- This warning lamp indicates low engine oil pressure. If the indicator comes on while the engine is running, stop the engine immediately and check for possible causes. Do not run the engine while this indicator is illuminated. Contact your Cub Cadet dealer to have the tractor and engine inspected.

**NOTE:** The oil pressure indicator may illuminate when the ignition switch is in the ON position, but should turn off when the engine is started.

#### PTO Engaged Indicator (Refer to Figure 9)

- This indicator illuminates when the PTO switch is pulled upward in the "ENGAGED" position and the ignition switch is turned to the "START" position. Check this indicator if the engine will not crank with the ignition switch in the "START" position. If necessary, move the PTO switch to the "DISENGAGED" position.

#### Parking Brake Engaged Indicator (Refer to Figure 9)

- This indicator illuminates when the parking brake is in the DISENGAGED position and the ignition switch is turned to the "START" position. Check this indicator if the engine will not crank with the ignition switch in the "START" position. If necessary, move the parking brake to the ENGAGED position.

This indicator also illuminates when the ignition switch is turned to the "START" position and the RH and/or LH drive control levers are in a position other than the fully out in neutral position. Move the control levers fully outward.

## M. Throttle Control

The throttle control is located on the LH console to the left of the operator's seat. When set in a given position, a uniform engine speed will be maintained.



This symbol indicates the fast position.



This symbol indicates the slow position.



This symbol indicates the choke position.

CHOKE

Figure 10

- Push the throttle control handle forward to increase the engine speed. The tractor is designed to operate with the throttle control in the fast position (full throttle) when the tractor is being driven and the mower deck is engaged.

- Pull the throttle control handle rearward to decrease the engine speed.
- When starting the engine, push the control handle fully forward into the "CHOKE" position. Refer to Figure 10. After starting and warming the engine, move the control handle rearward until you feel it move past the choke detent.

#### N. Parking Brake Engagement Lever

The parking brake engagement lever is located on the front/left of the seat box frame, and is used to engage the parking brake.

- Pull the lever fully upward and to the left; then lower into the "J" slot to engage the parking brake.
- Pull the lever up out of the "J" slot and to the right; then lower completely to disengage the parking brake.

**IMPORTANT:** *If the LH and RH drive control levers are not fully opened out in the neutral position when engaging the parking brake, the engine will stop. The parking brake must be placed in the engaged position when starting the tractor engine.*

---

## SECTION 2: OPERATION

### GENERAL SAFETY

- RECEIVE INSTRUCTION - Read the operator's manual. Learn to operate this machine SAFELY. Don't risk INJURY or DEATH. Allow only those who have become competent in its usage to operate this tractor .
- Familiarize yourself with the operations of all the instruments and controls.
- Before starting the engine or beginning operation, be familiar with the controls. The operator should be in the operator's seat. The PTO switch must be in the disengaged position, the parking brake engaged, and the RH and LH drive control levers moved fully outward in the neutral position.
- Keep all shields in place. Keep away from moving parts.
- NO RIDERS! Keep all people and pets a safe distance away. Look behind and down to both sides of the tractor before and while backing up.
- DO NOT direct the mower discharge at people.
- Avoid slopes where possible. Never operate on slopes greater than 15°. Slopes with a greater incline present dangerous operating conditions. Tractors can be rolled over.
- Before leaving the operator's seat: Shut off the PTO, move the RH and LH drive control levers fully outward in the neutral position, engage the parking brake, shut off the engine and remove the ignition key. Wait for all movement to stop before servicing or cleaning.
- Operate the drive control levers smoothly and avoid any sudden movements of the levers when starting and stopping. Keep a firm grip on the control levers; do not allow the levers to return to neutral on their own.
- Be careful when operating near roadways. Stop the tractor motion and wait for vehicles to pass before operating along the road.

- Do not operate the tractor with the mower deck removed. Removal of the deck will change the balance of the tractor, and could contribute to a tractor rollover.
- Avoid operation on traction surfaces that are unstable; use extreme caution if the surface is slippery.
- Slow down before turning and come to a complete stop before any zero turn maneuver.
- Do not stop the tractor or park the tractor over combustible materials such as dry grass, leaves, debris, etc.
- Do not fill the fuel tank when the engine is running or while the engine is hot. Allow the engine several minutes to cool before refueling. Tighten the fuel cap securely.

### BEFORE OPERATING YOUR TRACTOR

- Before you operate the tractor, study this manual carefully to familiarize yourself with the operations of all the instruments and controls. It has been prepared to help you operate and maintain your tractor efficiently.
- Familiarize yourself with the operations of all the instruments and controls.
- This engine is certified to operate on unleaded gasoline. For best results, fill the fuel tank with only clean, fresh, unleaded gasoline with a pump sticker octane rating of 87 or higher. In countries using the Research method, it should be 90 octane minimum.
- Unleaded gasoline is recommended because it leaves less combustion chamber deposits and reduces harmful exhaust emissions. Leaded gasoline is not recommended and must not be used where exhaust emissions are regulated.

**NOTE:** *Purchase gasoline in small quantities. Do not use gasoline left over from the previous season, to minimize gum deposits in the fuel system.*

- Gasohol (up to 10% ethyl alcohol, 90% unleaded gasoline by volume) is an approved fuel. Other gasoline/alcohol blends are not approved.
- Methyl Tertiary Butyl Ether (MTBE) and unleaded gasoline blends (up to a maximum of 15% MTBE by volume) are approved fuels. Other gasoline/ether blends are not approved.
- Check the engine oil level.
- Clean the air cleaner element if necessary.
- Check the tire inflation pressures.
- Adjust the seat for operator's maximum comfort, visibility and for maintaining complete control of the tractor.

### SAFETY INTERLOCK SYSTEM

This tractor is equipped with a safety interlock system for the protection of the operator. If the interlock system should ever malfunction, do not operate the tractor. Contact your authorized *Cub Cadet Dealer*.

- The safety interlock system prevents the engine from cranking or starting unless the RH and LH drive control levers are moved fully outward in the neutral position, the parking brake is engaged, and the PTO is disengaged.
- To avoid sudden movement when disengaging the parking brake, the safety interlock system will shut off the engine if the RH and/or LH drive control levers are moved to a position other than the fully out in neutral position when the parking brake is engaged.
- The safety interlock system will shut off the engine if the operator leaves the seat before engaging the parking brake.
- The safety interlock system will shut off the engine if the operator leaves the seat with the PTO engaged, regardless of whether the parking brake is engaged.

**NOTE:** *The PTO switch must be moved to the "OFF" position to restart the engine.*

- The safety interlock system will shut off the PTO and the mower blades will stop if both drive control levers are moved into the reverse position. The PTO will re-engage when one or both of the levers are moved back to the neutral or forward position.

### STARTING THE ENGINE



**WARNING:** This unit is equipped with a safety interlock system designed for the protection of the operator. Do not operate the tractor if any part of the interlock system is malfunctioning. Periodically check the functions of the interlock system for proper operation.



**WARNING:** For personal safety, the operator must be sitting in the tractor seat when starting the engine.

- Move the RH and LH drive control levers fully outward in the neutral position. Refer to Figure 11.
- Operator must be sitting in the tractor seat.
- Engage the parking brake. Refer to Figure 11.
- Make certain the PTO switch is in the disengaged (down) position. Refer to Figure 11.
- Move the throttle control lever fully forward into the "CHOKE" position. **NOTE:** *If the engine is warmed up, it may not be necessary to place the throttle control in the choke position.*

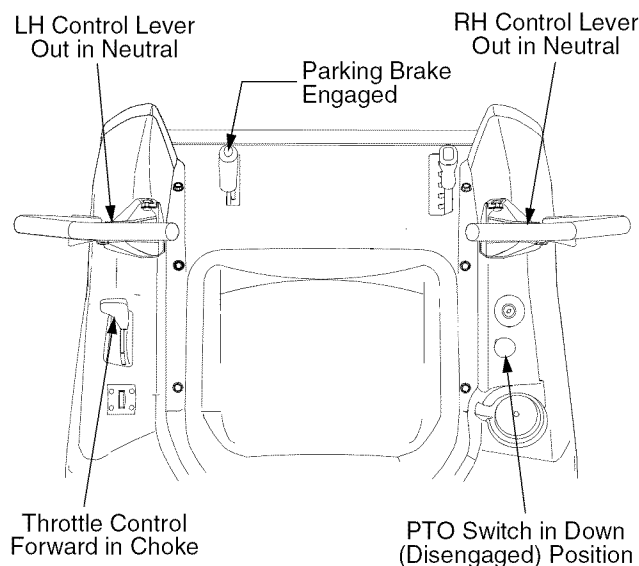

**Figure 11**

- Turn the ignition key clockwise to the "START" position and release it as soon as the engine starts; however, do not crank the engine continuously for more than 10 seconds at a time. If the engine does not start within this time, turn the key to "OFF" and wait a minute to allow the engine's starter motor to cool. Try again after waiting. If after a few attempts the engine fails to start, do not keep trying to start it with the choke closed as this will cause flooding and make starting more difficult.
- As the engine warms up, gradually pull the throttle control lever rearward past the choke detent position. Do not use the choke to enrich the fuel mixture, except as necessary to start the engine.
- Allow the engine to run for a few minutes at mid throttle before putting the engine under load.
- Observe the hour meter/indicator panel. If the battery indicator light or oil pressure light come on, immediately stop the engine. Have the tractor inspected by your *Cub Cadet dealer*.

## COLD WEATHER STARTING

- When starting the engine at temperatures near or below freezing, ensure the correct viscosity motor oil is used in the engine and the battery is fully charged. Start the engine as follows:
- Be sure the battery is in good condition. A warm battery has much more starting capacity than a cold battery.
- Use fresh winter grade fuel. Winter grade gasoline has higher volatility to improve starting. Do not use gasoline left over from summer.
- Follow the previous instruction for STARTING THE ENGINE.

## USING JUMPER CABLES TO START ENGINE



**WARNING: Batteries contain sulfuric acid and produce explosive gasses. Make certain the area is well ventilated, wear gloves and eye protection, and avoid sparks or flames near the battery.**

If the battery charge is not sufficient to crank the engine, recharge the battery. If a battery charger is unavailable and the tractor must be started, the aid of a booster battery will be necessary. Connect the booster battery as follows:

- Connect the end of one cable to the disabled tractor battery's positive terminal; then connect the other end of that cable to the booster battery's positive terminal.
- Connect one end of the other cable to the booster battery's negative terminal; then connect the other end of that cable to the frame of the disabled tractor, as far from the battery as possible.
- Start the disabled tractor following the normal starting instructions previously provided; then disconnect the jumper cables in the exact reverse order of their connection.
- Have the tractor's electrical system checked and repaired as soon as possible to eliminate the need for jump starting.

## STOPPING THE ENGINE

- Place the PTO switch in the "OFF" position.
- Move the RH and LH drive control levers fully outward in the neutral position.
- Engage the parking brake.

- Place the throttle control lever between half and full throttle.
- Turn the ignition key to the "OFF" position and remove the key from the ignition switch.

**NOTE:** *Always remove the key from the ignition switch to prevent accidental starting or battery discharge if the equipment is left unattended.*

## PRACTICE OPERATION (INITIAL USE)

Operating a zero-turn tractor is not like operating a conventional type riding tractor. Although and because a zero-turn tractor is more maneuverable, getting used to operating the control levers takes some practice.

We strongly recommend that you locate a reasonably large, level and open "practice area" where there are no obstructions, pedestrians, or animals. You should practice operating the tractor for a minimum of 30 minutes.

Carefully move (or have moved) the tractor to the practice area. When performing the practice session, the PTO should not be engaged. While practicing, operate the tractor at approximately 1/2-3/4 throttle and at less than full speed in both forward and reverse.

Carefully practice maneuvering the tractor using the instructions in the following section "Driving the Tractor." Practice until you are confident that you can safely operate the tractor.

## DRIVING THE TRACTOR



**WARNING: Avoid sudden starts, excessive speed and sudden stops.**



**WARNING: Do not leave the seat of the tractor without disengaging the PTO, moving drive control levers fully outward in the neutral position, and engaging the parking brake. If leaving the tractor unattended, turn the ignition key off and remove key.**

- Adjust the operator's seat to the most comfortable position that allows you to operate the controls. See seat adjustment in the **ADJUSTMENTS** section.
- Release the parking brake.

- Move the RH and LH drive control levers inward in the neutral position. See Figure 12.

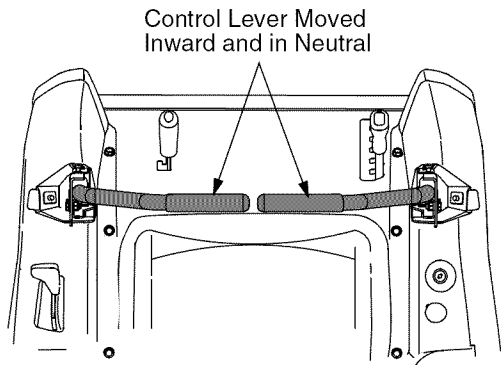

Figure 12

**NOTE:** If the control levers are not even in the neutral position, refer to Section 3 and adjust the levers so that they are even.

- Move the throttle control lever forward to the full throttle position (3500-3600 RPM). Make certain the throttle control has not been moved too far forward into the "Choke" position.

**NOTE:** The tractor and engine are designed to run at full throttle. If performing a practice session, it is preferable that the tractor is operated at less than full throttle (approximately 2500-3000 RPM), but this only applies to practice operation.



**WARNING:** Always maintain a firm grip on the control levers. Do not release the control levers to slow or stop the tractor; move the levers to the neutral position using your hands.

- To drive the tractor, firmly grasp the respective drive control levers with your right and left hands and proceed as follows :

#### Driving the Tractor Forward



**WARNING:** Keep all movement of the drive control levers slow and smooth. Abrupt movement of the control levers can affect the stability of the tractor and could cause the tractor to flip over, which may result in serious injury or death to the operator.

- Slowly and evenly move both drive control levers forward. The tractor will start to move forward. See Figure 13.
- As the control levers are pushed farther forward the speed of the tractor will increase.

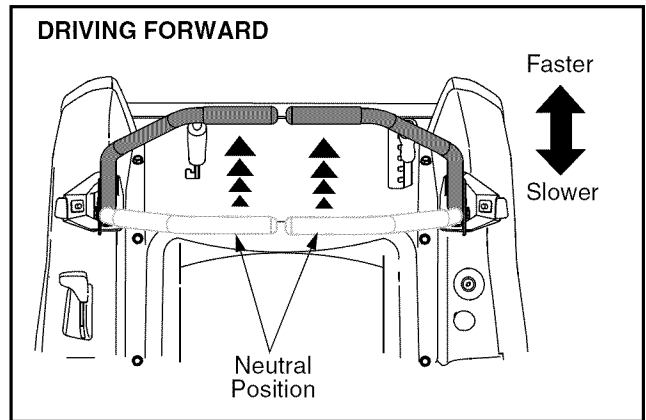

Figure 13

- To slow the tractor move the controls lever rearward to attain the desired speed, or move the levers to the neutral position to stop the tractor.

**IMPORTANT:** Always maintain your grasp on the drive control levers. Do not release the levers to slow the tractor or to return to neutral.

#### Turning the Tractor While Driving Forward



**WARNING:** When reversing the direction of travel, we recommend performing gradual 'U' turns where possible. Sharper turns increase the possibility of turf defacement, and could affect control of the tractor. ALWAYS slow the tractor before making sharp turns.

- To turn the tractor while driving forward, move the control levers as necessary so that one lever is rearward of the other. The tractor will turn in the direction of the rearward control lever.
  - To turn to the left, move the left drive control lever rearward of the right lever. See Figure 14.

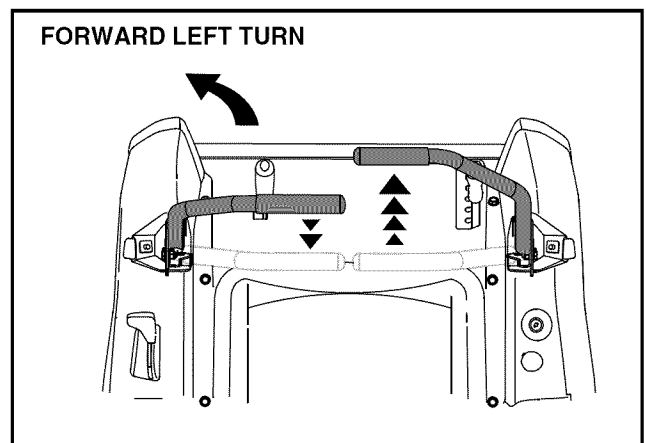

Figure 14



- To turn to the right, move the right drive control lever rearward of the left lever. See Figure 15.

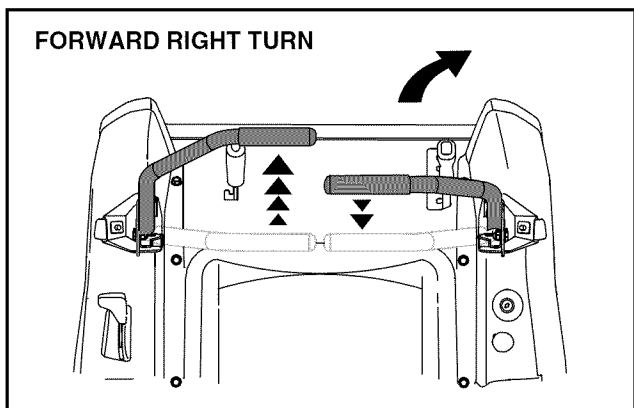

Figure 15

- The greater the fore-to-aft distance between the two levers, the sharper the tractor will turn.
  - To execute a "pivot turn," move the turn side drive control lever to the neutral position, while moving the other control lever forward.
- IMPORTANT: Making a "pivot turn" on grass will greatly increase the potential for defacement of the turf.**

#### Driving the Tractor In Reverse



**WARNING: Always look behind and down on both sides of the tractor before backing up. Always look behind while traveling in the reverse direction.**

- Slowly and evenly move both drive control levers rearward. The tractor will start to move in the reverse direction. See Figure 16.

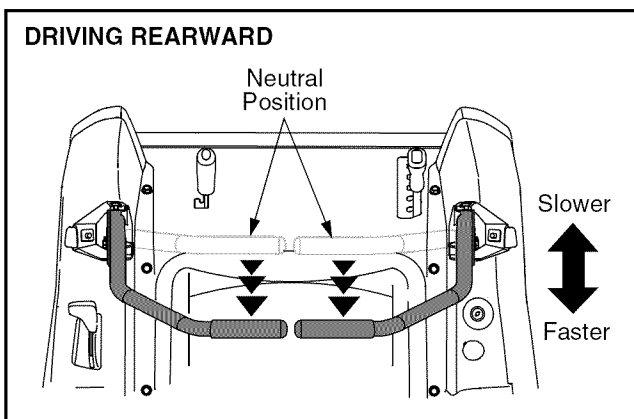

Figure 16

- As the control levers are pushed farther rearward the speed of the tractor will increase.
- To slow the tractor move the controls lever forward to attain the desired speed, or move the levers to the neutral position to stop the tractor.

**IMPORTANT: Always maintain your grasp on the drive control levers. Do not release the levers to slow the tractor or to return to neutral.**

#### Turning While Driving Rearward

- To turn the tractor while driving rearward, move the control levers as necessary so that one lever is forward of the other. The tractor will turn in the direction of the forward control lever.
- To turn to the left while traveling in reverse, move the left drive control lever forward of the right lever. See Figure 17.

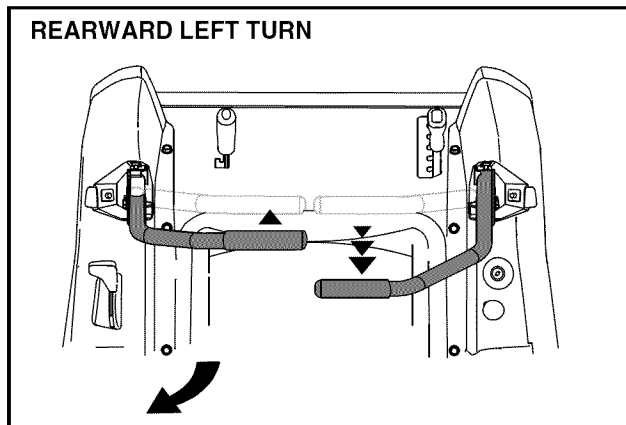

Figure 17

- To turn to the right while traveling in reverse, move the right drive control lever forward of the left lever. See Figure 18.

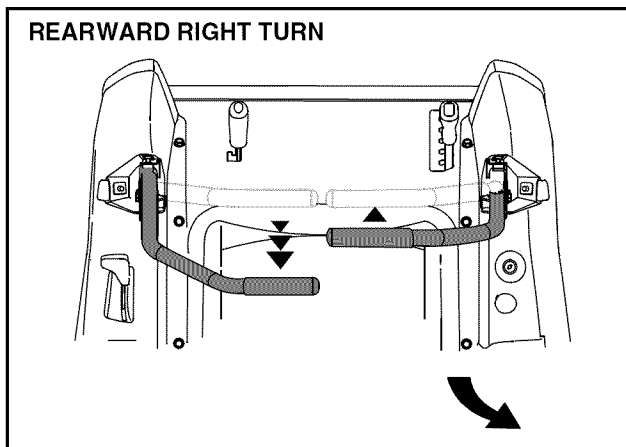

Figure 18

- The greater the fore-to-aft distance between the two levers, the sharper the tractor will turn.
  - To execute a "pivot turn," move the turn side drive control lever to the neutral position, while moving the other control lever rearward.
- IMPORTANT: Making a "pivot turn" on grass will greatly increase the potential for defacement of the turf.**

## Executing a Zero Turn



**WARNING:** When executing a zero turn, the tractor **MUST BE STOPPED**. Executing a zero turn while the tractor is moving can significantly reduce your control of the tractor and will cause severe turf defacement to occur.

- Stop the forward or reverse motion of the tractor by moving the two drive control levers to neutral.
- To turn clockwise, move the left control lever forward while simultaneously moving the right control lever rearward. See Figure 19.

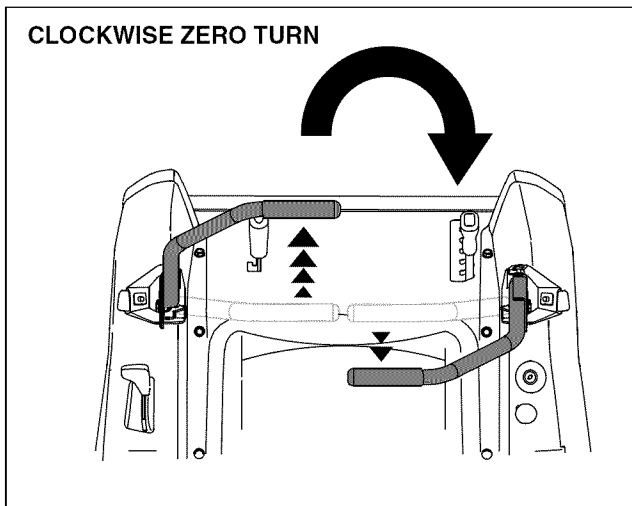

Figure 19

- To turn counterclockwise, move the right control lever forward while simultaneously moving the left control lever rearward. See Figure 20.

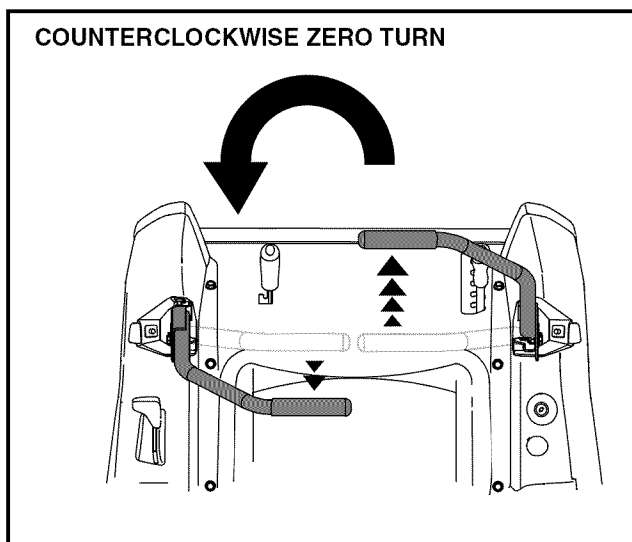

Figure 20

## STOPPING THE TRACTOR

- Move both drive control levers to the neutral position to stop the motion of the tractor.
- Push the PTO switch downward to the disengaged position.
- Use the deck lift handle to raise the deck to its highest position.
- If dismounting the tractor, move the drive control handles fully outward in the neutral position, engage the parking brake, place the throttle control lever between half and full throttle, turn the ignition switch to "OFF" and remove the key from the switch.

## DRIVING ON SLOPES

Refer to the SLOPE GAUGE on page 8 to help determine slopes where you may not operate safely.



**WARNING:** Do not operate on inclines with a slope in excess of 15 degrees (a rise of approximately 2-1/2 feet every 10 feet). The tractor could overturn and cause serious injury.

- Always drive across slopes, never up and down. Control the speed and direction of the tractor using primarily the control lever on the downhill side of the tractor, with the uphill control lever remaining essentially in a fixed position.
- Avoid turning downhill if possible. Start at the bottom of a slope and work upward. Always slow down before turning.
- Use extra care and go slowly when turning downhill.

## OPERATING THE PTO

Operate the PTO clutch as follows:

- Move the throttle control lever to approximately the mid throttle position.
- Pull the PTO switch upward to the "ENGAGED" position.
- Advance the throttle lever to the operating speed (full engine speed).
- The operator must remain in the tractor seat at all times. If the operator should leave the seat without turning off the power take-off switch, the tractor's engine will shut off.
- The PTO clutch cannot be operated when the tractor is driving in the reverse direction. The PTO will disengage when both drive control levers are moved to the reverse position, and will re-engage when one (or both) control lever(s) is moved to the neutral or forward position.

## USING THE MOWER DECK



**WARNING:** Make certain the area to be mowed is free of debris, sticks, stones, wire or other objects that can be thrown by the rotating blades.

**IMPORTANT:** Do not engage the mower deck when lowered in grass. Premature wear and possible failure of the "V" belt and PTO clutch will result. Fully raise the deck or move to a non grassy area before engaging the mower deck.

- Mow across slopes, not up and down. If mowing a slope, start at bottom and work upward to ensure turns are made uphill.
- On the first pass pick a point on the opposite side of the area to be mowed.
- Engage the PTO clutch using the PTO switch and move the throttle control to the fast position.
- Lower the mower deck to the desired height setting using the lift handle.
- Slowly and evenly push the RH and LH drive control levers forward to move the tractor forward, and keep the tractor headed directly toward the alignment point.

**NOTE:** The speed of the tractor will affect the quality of the mower cut. Mowing at full speed will adversely affect the cut quality. Control the ground speed with the control levers.

- When approaching the other end of the strip, slow down or stop before turning. A U-turn is recommended unless a pivot or zero turn is required.
- Align the mower with an edge of the mowed strip and overlap approximately 3 inches.
- Direct the tractor on each subsequent strip to align with a previously cut strip.
- To prevent rutting or grooving of the turf, if possible, change the direction that the strips are mowed by approximately 45° for the next and each subsequent mowing.



**WARNING:** Be careful when crossing gravel paths or driveways. Disengage the PTO and raise the deck to the highest position before crossing.

**IMPORTANT:** When stopping the tractor for any reason while on a grass surface, always:

- Place the control levers in neutral,
- Engage the parking brake,
- Shut engine off and remove the key.

Doing so will minimize the possibility of having your lawn "browned" by hot exhaust from your tractor's running engine.

## CHECKING THE SAFETY INTERLOCK CIRCUITS

Periodically check the safety interlock circuits to ensure they are working properly. If a safety circuit is not working as designed, contact your Cub Cadet dealer to have the tractor inspected. DO NOT operate the tractor if any safety circuit is not functioning properly. To check the safety circuits, proceed as follows:

- Sitting in the tractor seat with both drive control levers opened fully outward, disengage the parking brake and momentarily turn the ignition switch to the start position. The engine should not crank.
- Engage the parking brake and pull the PTO switch upward to the engaged position. Momentarily turn the ignition switch to the start position; the engine should not crank.
- Push the PTO switch downward to the disengaged position and engage the parking brake. Start the engine and move one of the drive control levers from the fully outward neutral position. The engine should stop running. Repeat the procedure with the opposite control lever.
- Move both control levers fully outward to the neutral position and disengage the parking brake; then lift upward from the operator's seat. The engine should stop.
- With both control levers fully outward in the neutral position and the parking brake engaged, engage the PTO. Lift upward from the operator's seat; the engine should stop.
- Start the tractor, disengage the parking brake, and move the control levers inward to the neutral operating position. Engage the PTO and move both control lever slowly into the slow reverse position; the PTO should disengage and the mower deck should stop until one or both of the control levers is moved to the neutral or forward position.

## SECTION 3: ADJUSTMENTS

### ADJUSTING THE OPERATORS SEAT

To adjust the position of the seat, move and hold the seat adjustment lever toward the left. Slide the seat forward or rearward to the desired position; then release the adjustment lever. Make sure seat is locked into position before operating the tractor. See Figure 21.

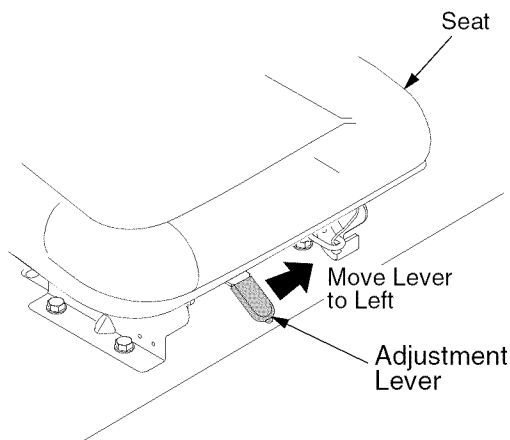

Figure 21

### ADJUSTING RH & LH DRIVE CONTROL LEVERS

The RH and LH drive control levers can be adjusted up or down and fore-and-aft for the comfort of the operator. The drive control levers can be placed in either of two height positions, and/or can be moved forward or rearward within the range of the slot in each control lever mounting bracket.

To adjust the drive control lever height, proceed as follows:

- Remove the flange lock nut, flat washer, and hex screw securing the lever to the pivot bracket.
- While supporting the control lever to keep it from falling, remove the hex insert flange lock nut and shoulder screw from the bottom of the control lever and pivot bracket. Refer to Figure 22.

- Reposition the control lever to align with the other set of holes in the pivot bracket and insert the shoulder screw removed earlier. Fasten with the hex insert flange lock nut and tighten until snug.
- Insert the hex screw w/washer through the control lever slot and the pivot bracket. Thread the flange lock nut onto the screw, but do not tighten now.
- If you are going to adjust the control levers forward or rearward, proceed to the next step. If not, fully the flange lock nut.

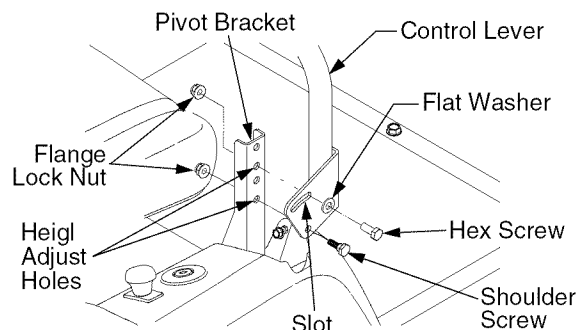

Figure 22

To adjust the drive control levers forward or rearward, proceed as follows:

If not already loose, loosen the flange lock nut and rotate the control lever either forward or rearward to the desired position. See Figure 22.

**NOTE:** *If the control lever is too tight to move, slightly loosen the hex insert flange lock nut and shoulder screw at the bottom of the control lever.*

- Tighten the flange lock nut to fix the control lever in the adjusted position
- Repeat the above procedure to adjust the other control lever into the same position. Adjust so that both levers are even with each other when in the neutral position.

## SECTION 4: MAINTENANCE

Perform all maintenance procedures at the intervals given in the instructions.

### ENGINE MAINTENANCE

Engine maintenance procedures must be performed at the intervals given in the following instructions.

#### Checking Engine Oil Level

Check engine oil level before each use as follows:

- Place the tractor on a flat surface and stop the engine. Allow the engine to cool long enough for the oil to drain into the engine sump.
- Clean the area around the oil dipstick/fill cap.
- Pull and remove the dipstick/fill cap and wipe the oil off. Reinsert the dipstick into the tube and push firmly into place. See Figure 23.

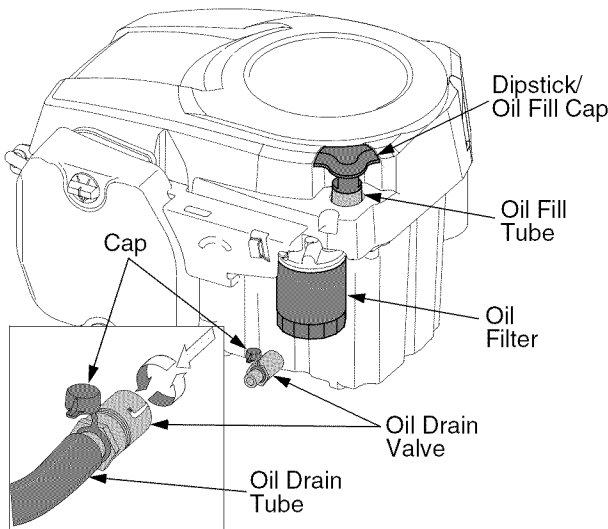

**Figure 23**

- Remove the dipstick and check the oil level. The oil level should be up to, but not over, the 'F' mark on the distick. See Figure 24.

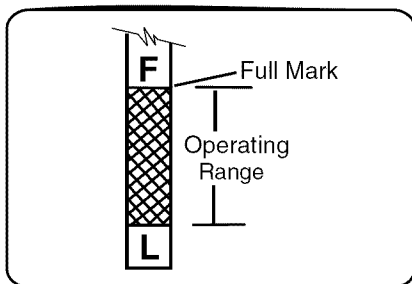

**Figure 24**

- If the level is low, add oil of the proper type, up to the 'F' mark on the dipstick. (Refer to the Recommended Viscosity Chart below.) Always check the level with the dipstick before adding more oil.

#### RECOMMENDED SAE VISCOSITY GRADES

-30°C	-20°C	-10°C	0°C	10°C	20°C	30°C	40°C
				10W-30			
**				*			
5W-20, 5W-30							
-22°F	-4°F	14°F	32°F	50°F	68°F	86°F	104°F
Temperature Range Expected Before Next Oil Change							

\* Use of synthetic oil having 5W-20 or 5W-30 rating is acceptable up to 40°F.

\*\* Synthetic oils will provide better starting in extreme cold (below -10°F)

**IMPORTANT:** Always maintain the proper oil level in the crankcase. Never operate the engine with the oil level below the 'L' mark or over the 'F' mark on the dipstick.

#### Changing Engine Oil & Filter

Change the engine oil and oil filter after every 100 hours of operation.

- Run the engine for a short time to warm the engine oil. The oil will flow more freely and carry away more impurities.
- Locate the oil drain valve on the right side of the engine. Pop open the protective cap on the end of the oil drain valve to expose the oil drain port. See Figure 23.
- Push the oil drain hose (packed with this manual) onto the oil drain port. Route the opposite end of the hose into an appropriate oil collection container with a capacity great enough to collect the used oil (1.6 qts.; 1.5 liters).
- Remove the dipstick/oil fill cap from the oil fill tube.
- Push the oil drain valve in slightly, then rotate counterclockwise and pull outward to begin draining oil. See Figure 23.
- After draining the oil, remove the drain hose, push the drain valve in and rotate clockwise to lock in the closed position. Push the protective cap back onto the drain valve.
- Remove the oil filter using an automotive type oil filter wrench (Refer to Figure 23). Wipe the filter adapter with a clean cloth.
- Place the new oil filter in a shallow pan with open end up. Pour new oil, of the proper type, into the center threaded hole. Stop pouring when the oil reaches the bottom of the threads. Allow a few minutes for the oil to be absorbed by the filter material.

- Apply a thin coat of new oil on the rubber gasket of the new oil filter.
- Install the new oil filter on the filter adapter. Hand tighten until the filter gasket contacts the adapter, then tighten the filter an additional 3/4-1 turn.
- Refill the engine with the proper type oil. The engine oil capacity is approximately (1.6 qts.; 1.5 liters).
- Reinstall the dipstick/oil fill cap and push firmly into place.

### Engine Air Filter Service

The engine is equipped with a replaceable, high density paper air cleaner element and an oiled, foam precleaner, located in the outer air cleaner cover.

Check the air cleaner before each use. Check for a buildup of dirt and debris around the air cleaner system. Keep this area clean. Also check for loose or damaged components. Replace all bent or damaged air cleaner components.



**WARNING: Operating the engine with loose or damaged air cleaner components could allow unfiltered air into the engine causing premature wear and failure.**

### Service the Air Filter Precleaner

Wash and reoil the precleaner every two months or every 25 hours of operation, (more often under extremely dusty or dirty conditions).

- Loosen the air cleaner cover knobs and remove the cover. Remove the precleaner from the cover. Refer to Figure 25.
- Wash the precleaner in warm water with detergent. Rinse the precleaner thoroughly until all traces of detergent are eliminated. Squeeze out excess water (do not wring). Allow the precleaner to air dry.
- Saturate the precleaner with new engine oil. Squeeze out all excess oil.
- Reinstall the precleaner into the upper section of the air cleaner cover. Make sure hole in precleaner is aligned with the upper mounting knob.
- Reinstall the air cleaner cover and secure with the two knobs.

### Service the Air Filter Paper Element

Check the paper element every two months or every 25 hours of operation, (more often under extremely dusty or dirty conditions). Clean or replace the element as necessary. Replace the air cleaner element annually, or every 100 hours.

- Remove the air cleaner cover. Service the pre-cleaner if required.

- Remove the air cleaner element with the integral rubber seal. See Figure 25.

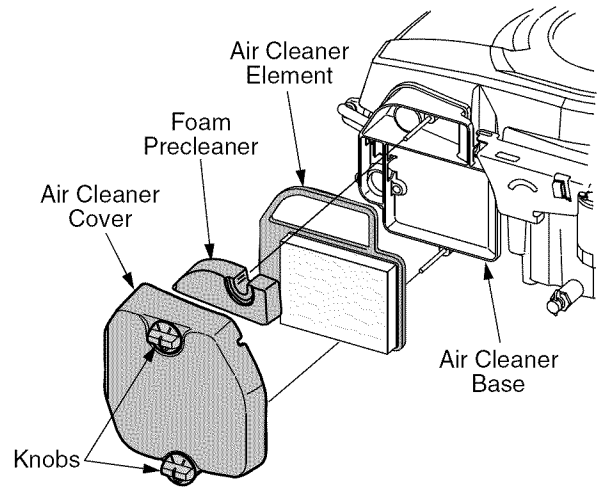

**Figure 25**

- Gently tap the pleated side of the paper element to dislodge dirt. **Do not** wash the paper element or use pressurized air, as this will damage the element. Replace a dirty, bent, or damaged element with a new element. Handle new elements carefully; do not use if the rubber seal is damaged.
- Clean all air cleaner components of any accumulated dirt or foreign material. Prevent any dirt from entering the throat of carburetor.
- Install the air cleaner element with the pleated side "out" and seat the rubber seal onto the edges of the air cleaner base. See Figure 26.

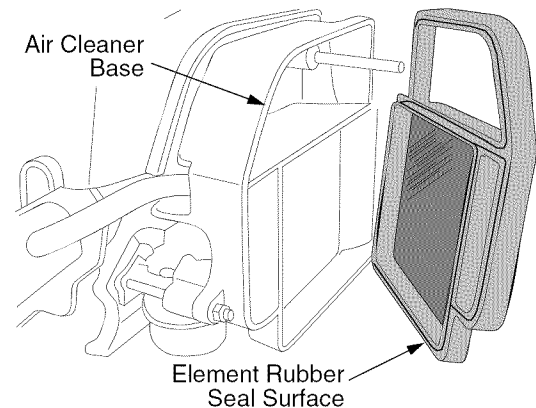

**Figure 26**

- Reinstall the pre-cleaner, into the upper section of the air cleaner cover. Make sure the hole in pre-cleaner is aligned with the upper mounting knob.
- Reinstall the air cleaner cover and secure with the two knobs.

## Clean Engine Cooling Areas

To ensure proper cooling, make sure the grass screen, cooling fins, and other external surfaces of the engine are kept clean at all times.

Annually or every 100 hours of operation (more often under extremely dusty, dirty conditions), remove the blower housing and cooling shrouds. Clean the cooling fins and external surfaces as necessary. Make sure the cooling shrouds are reinstalled. Torque the blower housing screws to 65 in. lb. (7.5 N·m).

**IMPORTANT:** Operating the engine with a blocked grass screen, dirty or plugged cooling fins, and/or cooling shrouds removed, will cause engine damage due to overheating.

## Service Engine Spark Plug

Every 2 years or 200 hours of operation, remove the spark plug, check condition, and reset the gap or replace with a new plug as necessary. Spark plug replacement is recommended at 500 hours.

- Before removing the spark plug, clean the area around the base of the plug to keep dirt and debris out of the engine. Due to the deep recess around the spark plug, blowing out the cavity with compressed air is usually the most effective method for cleaning. The spark plug is most accessible when the blower housing is removed for cleaning.
- Remove the plug and check its condition. Replace the plug if worn or reuse is questionable. NOTE: Do not clean the spark plug in a machine using abrasive grit. Some grit could remain in the spark plug and enter the engine causing extensive wear and damage.
- Check the gap using a wire feeler gauge. Adjust the plug gap to 0.030 in. (0.76 mm) by carefully bending the ground electrode. See Figure 27.

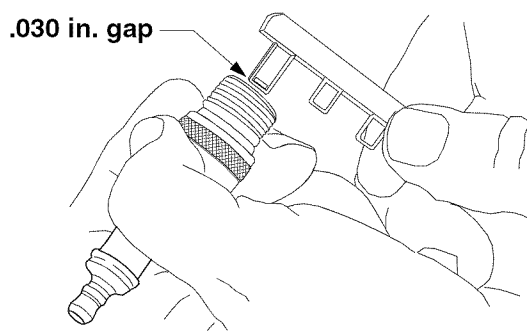

Figure 27

- Reinstall the spark plug into the cylinder head. Torque spark plug to 18-22 ft. lb. (24-30 N·m).
- Reconnect the spark plug lead and reinstall the blower housing, if removed previously. Torque the blower housing screws to 7.5 N·m (65 in. lb.).

## Service Engine Fuel Filter



**WARNING: Do not replace the fuel filter when engine is hot.**

The engine is equipped with an inline fuel filter. Visually inspect the filter periodically for a build-up of residue inside the filter body, and for a dirty element which can be indicated by discoloration. Replace the fuel filter when dirty.

## Carburetor

The carburetor's main fuel jet is calibrated at the factory and is not adjustable. The idle fuel needle is adjusted at the factory and has a limiter cap. All carburetor service should be performed by your Cub Cadet dealer.

If engine troubles are experienced that appear to be fuel system related, first make sure the fuel tank is filled with clean fresh fuel; the fuel tank cap vent is not blocked; the fuel lines are not restricted; and the fuel filter is clean and unobstructed. If the problem persists, have the carburetor and fuel pump checked.

## HYDROSTATIC TRANSMISSION MAINTENANCE

The zero turn tractor is equipped with dual integrated hydrostatic pumps, motors, and transaxles that are sealed and do not require regular maintenance.

All service work on the hydrostatic transmissions should be performed by your Cub Cadet dealer.

## GENERAL BATTERY INFORMATION



**WARNING:**

- Should battery acid accidentally splatter into the eyes or onto the skin, rinse the affected area immediately with clean cold water. If there is any further discomfort, seek prompt medical attention.
- If acid spills on clothing, first dilute it with clean water, then neutralize with a solution of ammonia/water or baking soda/water.
- NEVER connect (or disconnect) battery charger clips to the battery while the charger is turned on, as it can cause sparks.
- Keep all sources of ignition (cigarettes, matches, lighters) away from the battery. The gas generated during charging can be combustible.
- As a further precaution, only charge the battery in a well ventilated area.
- Always shield eyes and protect skin and clothing when working near batteries.



**WARNING: Batteries contain sulfuric acid and may emit explosive gases. Use extreme caution when handling batteries. Keep batteries out of the reach of children.**

## BATTERY REMOVAL



**WARNING: Battery posts, terminals and related accessories contain lead and lead compounds. Wash hands after handling.**

The battery is located on the right/rear of the tractor beneath the seat box frame. To remove the battery:

- Remove the two hex tapping screws from the battery holddown bracket and remove the bracket. Use care to avoid losing the trim strip from the bottom of the bracket. See Figure 28.

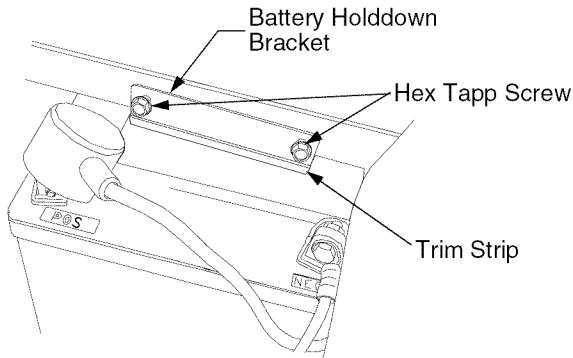

**Figure 28**

- Remove the hex cap screw and sems nut securing the black negative battery lead to the negative battery post (marked NEG). Move the cable away from the negative battery post.
- Remove the hex cap screw and sems nut securing the red positive battery lead to the positive battery post (marked POS).
- Carefully lift the battery out of the tractor.

Install the battery by repeating the above steps in the reverse order.



**WARNING: Always connect the positive lead to the battery before connecting the negative lead. This will prevent sparking or possible injury from an electrical short caused by contacting the tractor body with tools being used to connect the cables.**

## CHARGING THE BATTERY

Test and, if necessary, recharge the battery after the tractor has been stored for a period of time.

- A voltmeter or load tester should read 12.6 volts (DC) or higher across the battery terminals.
- Charge the battery with a 12-volt battery charger at a **MAXIMUM** rate of 10 amps.

Voltmeter Reading	State of Charge	Charging Time
12.7	100%	Full Charge
12.4	75%	90 Min.
12.2	50%	180 Min.
12.0	25%	280 Min.

## BATTERY MAINTENANCE

The battery is filled with battery acid and then sealed at the factory. However, even a “maintenance free” battery requires some maintenance to ensure its proper life cycle.

- Spray the terminals and exposed wire with a battery terminal sealer, or coat the terminals with a thin coat of grease or petroleum jelly, to protect against corrosion.
- Always keep the battery cables and terminals clean and free of corrosion.
- Avoid tipping. Even a sealed battery will leak electrolyte when tipped.

## BATTERY STORAGE

- When storing the tractor for extended periods, disconnect the negative battery cable. It is not necessary to remove the battery.
- All batteries discharge during storage. Keep the exterior of the battery clean, especially the top. A dirty battery will discharge more rapidly.
- The battery must be stored with a full charge. A discharged battery can freeze sooner than a charged battery. A fully charged battery will store longer in cold temperatures than hot.
- Recharge the battery before returning to service. Although the tractor may start, the engine charging system may not fully recharge the battery.

## SERVICING ELECTRICAL SYSTEM

A fuse is installed to protect the tractor’s electrical system from damage caused by excessive amperage. Always use the same capacity fuse for replacement. If the electrical system does not function, check for a blown fuse. See Figure 29

If you have a recurring problem with blown fuses, have the tractor’s electrical system checked by your Cub Cadet dealer.

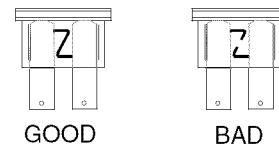

**Figure 29**

## Relays and Switches

There are several safety switches in the electrical system. If a function of the safety interlock system described earlier is not functioning properly, have the electrical system checked by your Cub Cadet dealer.



## LUBRICATION

After every 10 hours of operation, use a pressure lubricating gun to apply Cub Cadet 251H EP grease through the lube fittings for the front castor shafts, front pivot axle, and front castor wheels.

Periodically lubricate all other pivot points with a quality lubricating oil.

Refer to the "MOWER DECK" section later in this manual for deck lubrication procedures.

## TIRE MAINTENANCE

Check the tire air pressure after every 50 hours of operation or weekly. Keep the tires inflated to the recommended pressures. Improper inflation will shorten the service life of a tire. See the tire side wall for proper inflation pressures. Observe the following guidelines:

- Do not inflate a tire above the maximum pressure shown on the sidewall of the tire.
- Do not reinflate a tire that has been run flat or seriously under inflated. Have a qualified tire mechanic inspect and service the tire.

## USING THE TRANSMISSION BYPASS RODS

If for any reason the tractor will not drive or you wish to move the tractor, the two hydrostatic transmissions are equipped with a bypass rod that will allow you to manually move the tractor short distances.



**WARNING: Do not tow the tractor, even with the bypass rod engaged. Serious transmission damage will result from doing so.**

- From just in front of the two rear tires, locate the transmission bypass rods. See Figure 30.

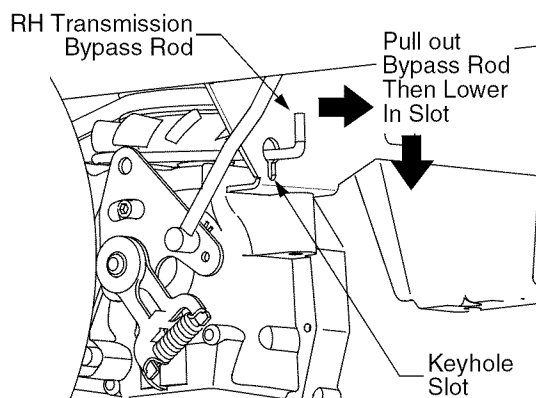

**Figure 30**

- Pull one rod toward the front of the tractor until the flange on the rod is forward of the keyhole slot in the frame assembly.

- Lower the bypass rod into the keyhole slot and release so the rod flange is against the front of the frame bracket.
- Repeat the above procedure to engage the other bypass rod.
- After moving the tractor, disengage both bypass rods. Lift the rod and guide the flange of the rod back through the larger circular opening of the keyhole, then release the rod.

**IMPORTANT: The tractor will not drive with the bypass rods in the engage position.**

## TRACTOR CREEPING

Creeping is the slight forward or backward movement of the tractor when the engine is running at high idle and the drive control levers are opened out in the neutral position.

If after operating the tractor for some time, it begins to creep while in the neutral position, adjust the transmission control rods as follows.

- Place the front of the tractor against an immovable object (e.g. wall, post, etc.).
- Jack up the rear of the tractor so that both rear wheels are approximately one inch of the ground.
- With the engine running at high idle and the drive control levers opened out in the neutral position, and the parking brake disengaged, check the rear wheels for rotation.
- If only one wheel is rotating, locate the transmission control rod beneath the frame at the front of the rear tire. If both wheels rotate, locate both control rods. See Figure 31.

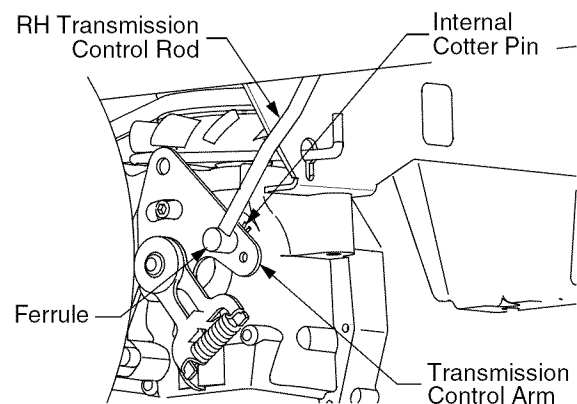

**Figure 31**

- Remove the internal cotter pin securing the ferrule to the transmission control arm and withdraw the ferrule. Wheel rotation should stop. If it does not, contact your Cub Cadet dealer.

- If the rotation stops, adjust the ferrule up or down the control rod as necessary to align with the hole in the transmission control arm. Re-insert the ferrule into the hole in the control arm and secure with the internal cotter pin.
- If necessary, repeat the previous two steps to adjust the other transmission control rod.
- Lower the tractor and remove the jack.

### TRACTOR HIGH SPEED TRACKING

If the tractor tracks to one side with both drive control levers fully forward, adjust the control levers as follows:

- Check for proper and balanced air pressure in both front and rear tires. Refill tires if necessary.
- Perform the first three steps in the previous subsection, Tractor Creeping, to verify that the tractor is not creeping. If creeping, adjust following the instructions in that sub-section.
- Recheck the tracking after making any adjustments to the transmission control rods.
- If uneven tracking persists, note which direction the tractor is tracking.
  - If the tractor tracks to the right, adjust the control lever stop bolt on the left side.
  - If the tractor tracks to the left, adjust the control lever stop bolt on the right side.
- Locate the applicable stop bolt on the left or right console. See Figure 32.

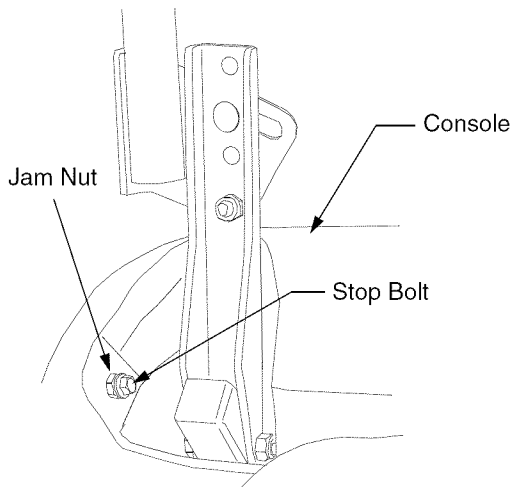

Figure 32

- Loosen the jam nut on the stop bolt, then turn the stop bolt counterclockwise to make it longer. Recheck the tracking and fine tune the adjustment as necessary.  
**NOTE:** If the stop bolt is adjusted too far, the tracking problem will change sides. Make fine tuning adjustments by shortening the same bolt.

- Tighten the jam nut against the console and reposition the control lever if necessary.

### TRANSMISSION DRIVE BELT

If the transmission drive belt becomes worn and causes the drive transmissions to slip, the drive belt must be replaced. To replace the drive belt, proceed as follows:

- Remove the deck drive belt from the PTO clutch on the bottom of the engine following the instructions in Deck Removal, SECTION 5: MOWER DECK.
- From beneath the rear of the tractor, insert a 3/8 inch drive ratchet into the square hole of the drive idler bracket. See Figure 33.

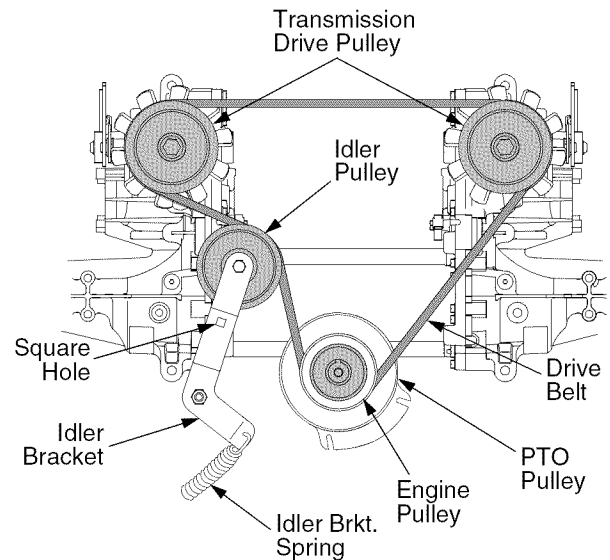

Figure 33

- Using the ratchet for leverage, pivot the idler bracket and idler pulley away from the backside of the 'V' belt; then lift the belt off and **above** the engine pulley and off the idler pulley.
- With the belt loose, lift the belt off, up and over the two transmission drive pulleys. Remove the belt from the engine and idler pulleys.
- Loop the new belt and slide over and onto the two transmission pulleys.
- Route the belt above the idler bracket back to the engine drive pulley. Lift the belt over the PTO pulley and above the engine drive pulley.
- Using the ratchet for leverage, pivot the idler bracket and idler pulley against the spring tension; then slip the belt down into the engine drive pulley and onto the idler pulley.
- Release the idler bracket so that the idler pulley tightens against the back side of the belt and tensions the drive belt.
- Reinstall the deck drive belt.

## TRACTOR STORAGE

If your tractor is not going to be operated for an extended period of time (thirty days to approximately six months), the tractor should be prepared for storage. Store the tractor in a dry and protected location. If stored outside, cover the tractor (including the tires) to protect it from the elements. The procedures outlined below should be performed whenever the tractor is placed in storage.

1. Change the engine oil and filter following the instructions provided in the engine information at the back of this manual.



**WARNING:** Never store the tractor with fuel in the tank indoors or in poorly ventilated enclosures, where fuel fumes may reach an open flame, spark or pilot light as on a furnace, water heater, clothes dryer, etc.



**WARNING:** Fuel left in the fuel tank deteriorates and will cause serious starting problems.

2. **If storing the tractor for 30 days or more:**

To prevent gum deposits from forming inside the engine's carburetor and causing possible malfunction of the engine, the fuel system must be either completely emptied, or the gasoline must be treated with a stabilizer to prevent deterioration.

### Using a fuel stabilizer:

- Read the product manufacturer's instructions and recommendations.
- Add to clean, fresh gasoline the correct amount of stabilizer for the capacity (approximately 3 gallons) of the fuel system.
- Fill the fuel tank with treated fuel and run the engine for 2-3 minutes to get stabilized fuel into the carburetor.

### Emptying the fuel system:

- Prior to putting the tractor in storage, monitor fuel consumption with the goal of running the fuel tank empty.
  - Run the engine until it begins to stall. Keep the engine running until all fuel in the carburetor has been exhausted.
3. Clean the engine and the entire tractor thoroughly.
  4. Fully charge the battery, then disconnect the negative cable at the battery to prevent possible discharge. Recharge the battery periodically when in storage.

**NOTE:** Remove the battery if exposed to prolonged periods of sub-freezing temperatures. Store in a cool, dry location where temperatures are above freezing.

5. Lubricate all lubrication points.

**NOTE:** We do not recommend the use of a pressure washer or garden hose to clean your tractor. They may cause damage to electrical components; spindles; pulleys; bearings; or the engine. The use of water will result in shortened life and reduce serviceability.

## REMOVING THE TRACTOR FROM STORAGE

- Check the engine oil.
- Fully charge the battery and inflate the tires to the recommended pressure.
- Add clean, fresh fuel.
- Start the engine and allow to idle for a few minutes to ensure engine is operating properly.
- Drive the tractor without a load to make certain all the tractor systems are functioning properly.

## SECTION 5: MOWER DECK

This section contains removal, installation, adjustment, and maintenance information for the 42-inch mower deck.

### DECK REMOVAL

Remove the mower deck from the tractor as follows:

1. Move the tractor to a level surface, disengage the PTO, stop the engine, and set the parking brake.
2. Move the deck gauge wheels to their highest setting (lowest deck setting).
3. Remove the 'V' belt from the PTO pulley, located on the bottom of the engine, using one of the following two methods.

#### Releasing belt tension with the idler pulley.

- Using the deck lift handle, raise the deck to the upper position that allows for the most horizontal run of the belt between the deck idler pulleys and the PTO pulley on the bottom of the engine.
- Working from the middle of the tractor, pivot the idler bracket and movable idler pulley rearward away from the backside of the 'V' belt just far enough to lift the belt up and over the idler pulley. See Figure 34.

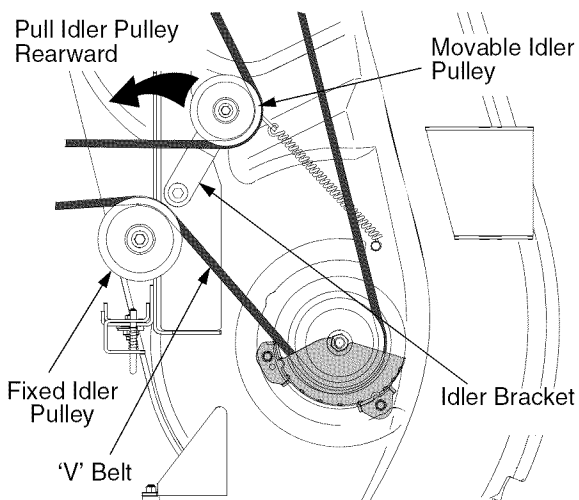

Figure 34



**WARNING:** The muffler at the rear of the tractor may be extremely hot, and could cause serious burns. Use extreme caution when near the muffler, or allow the muffler to fully cool before removing the belt.

- From beneath the rear of the tractor, slide the belt off of the PTO pulley on the bottom of the engine.

#### Rolling the belt off the PTO pulley.

- Using the deck lift handle, raise the deck to the upper position that allows for the most horizontal run of the belt between the deck idler pulleys and the PTO pulley on the bottom of the engine.



**WARNING:** The muffler at the rear of the tractor may be extremely hot, and could cause serious burns. Use extreme caution when near the muffler, or allow the muffler to fully cool before removing the belt.

- Sitting behind the tractor facing forward, reach beneath the tractor to grasp the belt at the front of the PTO pulley.



**WARNING:** Use caution to prevent pinching your fingers when rolling the belt off the PTO pulley.

- Pull the left side of the belt rearward and downward while manually turning the PTO pulley to the right until the belt rides out onto the edge of the lower sheave of the pulley. **NOTE:** If pulling the right side of the belt, turn the pulley to the left.
  - While still holding the belt downward, continue turning the PTO pulley until the belt is rolled off the pulley.
4. Lower the deck to the ground using the deck lift handle.
  5. Locate the LH and RH deck support pins on each side of the deck. Pull the deck support pins outward and lock in the disengaged position to release the deck from the tractor's LH and RH deck lift arms. See Figure 35.

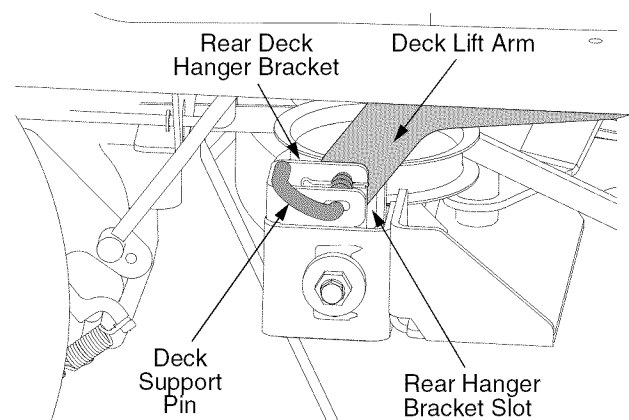

Figure 35

6. Raise the deck lift arms out of the rear hanger bracket slots by raising the deck lift handle on the tractor to its highest position.

7. Slide the deck forward so that the deck front hanger rod can be lifted out of the two slots of the front deck bracket. After lifting the front hanger rod out of the slots, slide the deck rearward so that the rod can no longer engage the slots.
8. Using care to prevent the front hanger rod from falling back into the deck slots, gently slide the cutting deck (from the right side) out from underneath the tractor.

## DECK INSTALLATION

To install the mower deck, proceed as follows:

1. While holding up the deck front hanger rod, carefully slide the deck underneath the right side of the tractor.
2. While still holding the front hanger rod, slide the deck forward until the front hanger rod can be lowered into the slots at the front of the deck.
3. Lower the front hanger rod into the slots of the front deck bracket, then slide the deck rearward.
4. Maneuver the deck so that the slots in the two rear deck hanger brackets approximately align with the deck lift arms of the tractor. Refer to Figure 35.
5. Use the deck lift handle of the tractor to lower the deck lift arms into the slots of the rear deck hanger brackets.
6. Pull the deck support pins outward and maneuver the deck as necessary to align the holes in the deck lift arm with the pins. Refer to Figure 35.
7. When aligned, push each pin fully inward through the lift arms to secure the arms in the rear hanger bracket slots.
8. Make certain the 'V' belt is in the spindle pulleys on the deck, then route the belt rearward beneath the tractor frame and above the two transmission tubes.
9. Install the 'V' belt onto the PTO pulley using one of the following two methods.

### Using the idler pulley to tension the belt.

- Using the deck lift handle, raise the deck to the upper position that allows for the most horizontal run of the belt between the deck idler pulleys and the PTO pulley on the bottom of the engine.



**WARNING:** The muffler at the rear of the tractor may be extremely hot, and could cause serious burns. Use extreme caution when near the muffler, or allow the muffler to fully cool before removing the belt.

- Install the belt in the PTO pulley on the bottom of the engine.

- Route the backside of the belt around the fixed idler pulley of the deck. Refer to Figure 34.
- Working from the middle of the tractor, pivot the idler bracket/movable pulley rearward against the spring tension and slide the backside of the belt onto the movable idler pulley. Refer to Figure 34.

### Rolling the belt into the PTO pulley.

- Using the deck lift handle, raise the deck to the upper position that allows for the most horizontal run of the belt between the deck idler pulleys and the PTO pulley on the bottom of the engine.
- Make certain the belt is in the spindle pulleys of the deck, and that the backside of the belt is against both the fixed and movable idler pulleys. Refer to Figure 34.



**WARNING:** The muffler at the rear of the tractor may be extremely hot, and could cause serious burns. Use extreme caution when near the muffler, or allow the muffler to fully cool before removing the belt.

- Sitting behind the tractor, facing forward, make certain the belt is not twisted; then reach beneath the tractor to grasp the belt and pull it toward the PTO pulley.



**WARNING:** Use caution to prevent pinching your fingers when rolling the belt onto the PTO pulley.

- Pull the right side of the belt rearward and place the narrow V side of the belt into the PTO pulley. See Figure 36.
- While holding the belt and pulley together, rotate the pulley to the left (See Figure 36). Continue holding and rotating the pulley and belt until the belt is fully rolled into the PTO pulley. **NOTE:** If using the left side of the belt, turn the pulley to the right.

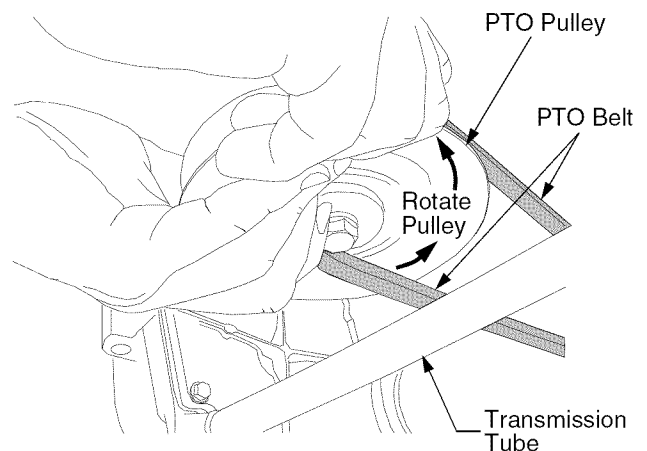

Figure 36

## LEVELING THE MOWER DECK

When leveled correctly the mower deck should be level side to side, and should be approximately a 1/8 to 1/4 inch lower in the front of the deck.

### Side to Side Leveling

If the cutting deck appears to be mowing unevenly, a side to side adjustment can be performed. Adjust if necessary as follows:

- With the tractor parked on a firm, level surface, place the deck lift handle in the top notch (highest position) and rotate both blades so that they are perpendicular to the tractor frame.
- Measure the distance from the outside left blade tip to the ground and the distance from the outside right blade tip to the ground. The measurements should be equal. If they're not, proceed to the next step.
- Comparing the two measurements, determine whether the right side of the deck must be raised or lowered.
- Loosen, but do not remove, the hex cap screw on the right deck hanger bracket. Refer to Figure 37.
- Level the deck by using a wrench to turn the adjustment gear (found immediately behind the hex cap screw just loosened) clockwise to lower the right side of the deck, or counterclockwise to raise the right side of the deck. See Figure 37.

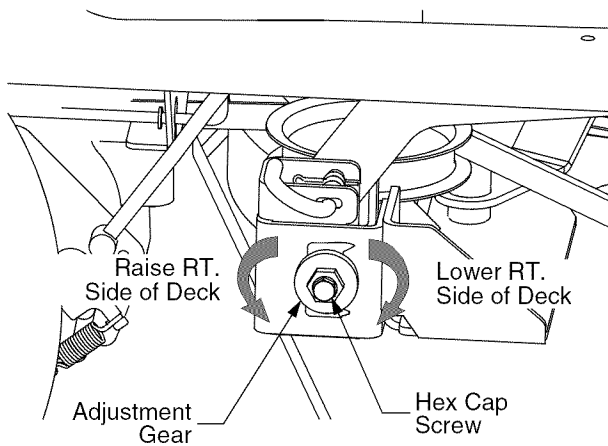

Figure 37

- The deck is properly leveled when both blade tip measurements taken earlier are equal.
- Retighten the hex cap screw on the right deck hanger bracket when proper adjustment is achieved.

### Front to Back Leveling.

The front of the deck should be approximately 1/8 to 1/4 inch lower than the rear of the deck. Adjust if necessary as follows:

- With the deck raised off of the ground, rotate the blades so that they are parallel to the frame of the tractor.
- If the side to side leveling was done correctly, measuring just the right blade should be acceptable to attain the correct back to front pitch of the deck.
- Measure the distance from the front tip of the blade to the ground and the distance from the rear tip to the ground. The front distance should be 1/8 to 1/4 inch less than the rear. If it is not, proceed to the next step.
- From the front of the tractor, loosen the outer nuts on the deck front hanger rod, and turn them away from the inner nuts. See Figure 38.

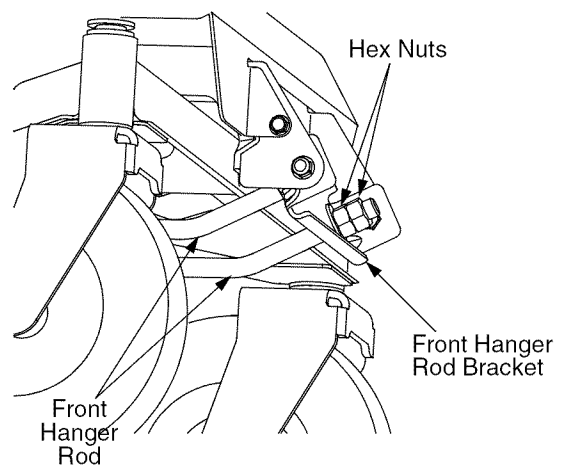

Figure 38

- If the front of the deck was too low, turn the inner hex nuts clockwise against the hanger bracket to shorten the front hanger rod and raise the front of the deck. See Figure 38.
- If the front of the deck was too high, turn the hex nuts counterclockwise to lengthen the front hanger rod and lower the front of the deck.

**IMPORTANT:** *The deck front hanger rod should be at the front of the slots of the front deck bracket. If one side of the rod is not at the front of its slot, turn the inner hex nut on that side until rod just touches the front of the slot. Then re-measure and re-adjust the front hanger rod as necessary.*

- When the correct pitch of the deck is acquired, secure the inner hex nuts with a wrench and tighten the outer hex nuts against the inner hex nuts to lock them in the adjusted position.

## ADJUSTING THE GAUGE WHEELS

The cutting height of the mower deck can be set in any of six height settings using the deck lift handle of the tractor. The deck heights range from 1-1/2 inches to 4 inches. The deck gauge wheel position should be approximately 1/4 to 1/2 inch above the ground when the deck is set in the desired height setting.



**WARNING: Keep hands and feet away from the discharge opening of the cutting deck.**

*NOTE: The deck wheels are an anti-scalp feature of the deck and are not designed to support the weight of the cutting deck.*

Using the lift handle, set the deck in the desired height setting, then check the gauge wheel and if necessary adjust as follows.

- With the deck set at the desired height, visually check the distance between the gauge wheels and the ground. If the gauge wheels are near or touching the ground, they should be raised. If the gauge wheels are more than 1/2" above the ground, they should be lowered.
- Remove the lock nut securing one of the gauge wheel shoulder screws to the deck. Remove the gauge wheel and shoulder screw. See Figure 39.

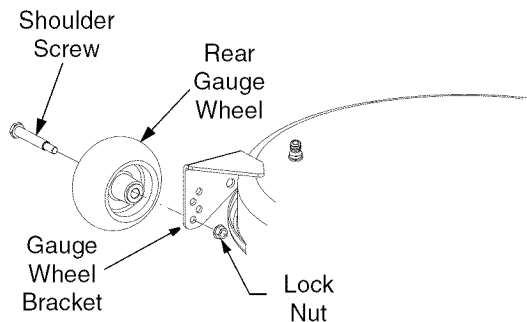

Figure 39

- Insert the shoulder screw in the one of four index holes that will give the gauge wheel a 1/4 to 1/2 inch clearance with the ground.
- Note the index hole of the just adjusted wheel; adjust the other gauge wheel into the respective index hole on the other side of the deck.

## DECK MAINTENANCE

### Using the Deck Wash System



**WARNING: When using the deck wash system, never engage the deck from any position other than the operator's seat of the tractor. Do not use an assistant or engage deck in the presence of any bystanders.**

- Attach the nozzle adapter to a standard garden hose connected to a water supply.
- Move the tractor to an area within reach of the hose where the dispersal of wet grass clippings is not objectionable to you. Disengage the PTO, engage the parking brake, and stop the engine.
- Pull back the lock collar of the nozzle adapter and push the adapter onto the deck wash nozzle at the left end of the mower deck. Release the lock collar to lock the adapter on the nozzle. See Figure 40.

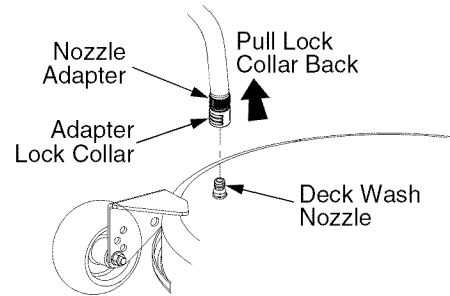

Figure 40

- Turn on the water supply.
- From the tractor operator's seat, start the engine and engage the PTO. Allow to run as needed. Disengage the PTO and stop the engine.
- Turn off the water supply.
- Pull back the lock collar of the nozzle adapter to disconnect the adapter from the nozzle.

### Cleaning the Spindle Pulleys

Once a month remove any accumulation of grass clippings from around the spindle pulleys and V-belt. Clean more often when mowing tall, dry grass.

### Mower Blade Care



**WARNING: Before performing any maintenance, place the PTO switch in the "OFF" position, engage the parking brake lever, turn the ignition key to the "OFF" position and remove the key from the switch. When servicing the mower deck, be careful not to cut yourself on the sharpened blades.**

The cutting blades must be kept sharp at all times. Sharpen the cutting edges of the blades evenly so that the blades remain balanced and the same angle of sharpness is maintained.

If the cutting edge of a blade has already been sharpened many times, or if any metal separation is present, it is recommended that new blades be installed. New blades are available at your authorized dealer.

The blades may be removed as follows.

- Remove the deck from beneath the tractor, (refer to **Deck Removal** on page 28) then gently flip the deck over to expose its underside.
- Use a 15/16 inch wrench to hold the hex nut on top of the spindle assembly when loosening the hex nut securing the blade. A block of wood may be placed between the deck housing and the cutting edge of the blade to help in breaking loose the hex nut securing the blade. See Figure 41.

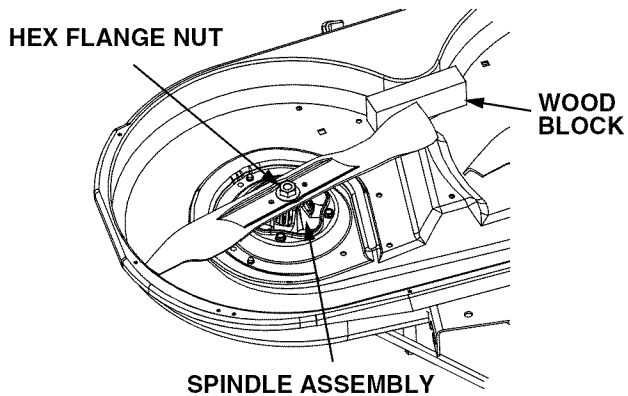

Figure 41

- When reinstalling the blades, be sure they are installed so that the wind wings are pointing

upward toward the top of the deck. Tighten the blade nuts to 70-90 ft. lbs.

- Reinstall the deck (refer to **Deck Installation** on page 29).

#### DECK LUBRICATION

- After every 10 hours of operation and before putting the deck into winter storage, lubricate the spindle assemblies with 251H EP grease or an equivalent No.2 multipurpose lithium grease. The lube fittings are located in the spindle housing and can be accessed from underneath the deck.

#### REPLACING THE DECK DRIVE BELT

- Remove the deck from beneath the tractor, (refer to **Deck Removal** on page 28).
- Remove the hex tapping screws securing the belt covers to the deck and remove the belt from the spindle pulleys. Refer to Figure 42.
- Install the new belt around the spindle pulleys and reinstall the belt covers.
- Route the belt rearward between the two idler pulleys and reinstall the deck following the instructions in **Deck Installation** on page 29.

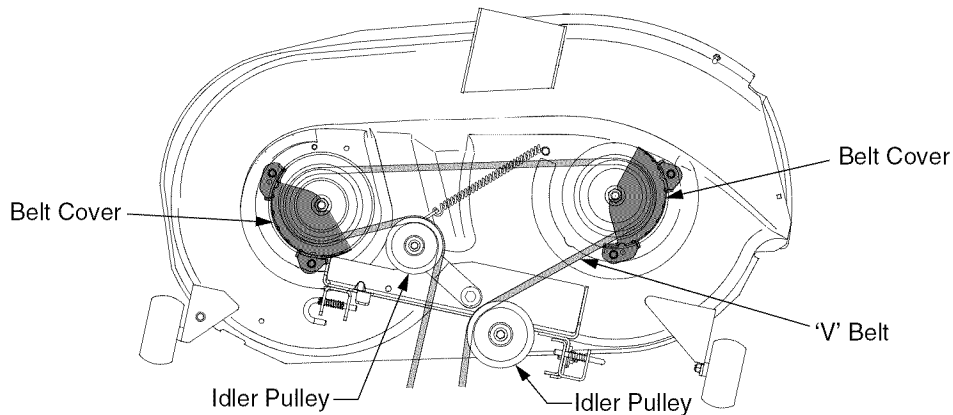

Figure 42





**KOHLER CO.  
FEDERAL AND CALIFORNIA EMISSION CONTROL SYSTEMS  
LIMITED WARRANTY  
SMALL OFF-ROAD EQUIPMENT ENGINES**

The U.S. Environmental Protection Agency (EPA), the California Air Resources Board (CARB), and Kohler Co. are pleased to explain the Federal and California Emission Control Systems Warranty on your small off-road equipment engine. For California, engines produced in 1995 and later must be designed, built and equipped to meet the state's stringent anti-smog standards. In other states, 1997 and later model year engines must be designed, built and equipped, to meet the U.S. EPA regulations for small non-road engines. The engine must be free from defects in materials and workmanship which cause it to fail to conform with U.S. EPA standards for the first two years of engine use from the date of sale to the ultimate purchaser. Kohler Co. must warrant the emission control system on the engine for the period of time listed above, provided there has been no abuse, neglect or improper maintenance.

The emission control system may include parts such as the carburetor or fuel injection system, the ignition system, and catalytic converter. Also included are the hoses, belts and connectors and other emission related assemblies.

Where a warrantable condition exists, Kohler Co. will repair the engine at no cost, including diagnosis (if the diagnostic work is performed at an authorized dealer), parts and labor.

#### **MANUFACTURER'S WARRANTY COVERAGE**

Engines produced in 1995 or later are warranted for two years in California. In other states, 1997 and later model year engines are warranted for two years. If any emission related part on the engine is defective, the part will be repaired or replaced by Kohler Co. free of charge.

#### **OWNER'S WARRANTY RESPONSIBILITIES**

- (a) The engine owner is responsible for the performance of the required maintenance listed in the owner's manual. Kohler Co. recommends that you retain all receipts covering maintenance on the engine. But Kohler Co. cannot deny warranty solely for the lack of receipts or for your failure to assure that all scheduled maintenance was performed.
- (b) Be aware, however, that Kohler Co. may deny warranty coverage if the engine or a part has failed due to abuse, neglect, improper maintenance or unapproved modifications.
- (c) For warranty repairs, the engine must be presented to a Kohler Co. service center as soon as a problem exists. Call 1-800-544-2444, or access our web site at: [www.kohlerengines.com](http://www.kohlerengines.com), for the names of the nearest service centers. The warranty repairs should be completed in a reasonable amount of time, not to exceed 30 days.

If you have any questions regarding warranty rights and responsibilities, you should contact Kohler Co. at 1-920-457-4441 and ask for an Engine Service representative.

#### **COVERAGE**

Kohler Co. warrants to the ultimate purchaser and each subsequent purchaser that the engine will be designed, built and equipped, at the time of sale, to meet all applicable regulations. Kohler Co. also warrants to the initial purchaser and each subsequent purchaser, that the engine is free from defects in material and workmanship which cause the engine to fail to conform with applicable regulations for a period of two years.

Engines produced in 1995 or later are warranted for two years in California. For 1997 and later model years, EPA requires manufacturers to warrant engines for two years in all other states. These warranty periods will begin on the date the engine is purchased by the initial purchaser. If any emission related part on the engine is defective, the part will be replaced by Kohler Co. at no cost to the owner. Kohler Co. is liable for damages to other engine components caused by the failure of a warranted part still under warranty.

Kohler Co. shall remedy warranty defects at any authorized Kohler Co. engine dealer or warranty station. Warranty repair work done at an authorized dealer or warranty station shall be free of charge to the owner if such work determines that a warranted part is defective.

Listed below are the parts covered by the Federal and California Emission Control Systems Warranty. Some parts listed below may require scheduled maintenance and are warranted up to the first scheduled replacement point for that part. The warranted parts are:

- Oxygen sensor (if equipped)
- Intake manifold (if equipped)
- Exhaust manifold (if equipped)
- Catalytic muffler (if equipped)
- Fuel metering valve (if equipped)
- Spark advance module (if equipped)
- Crankcase breather
- Ignition module(s) with high tension lead
- Gaseous fuel regulator (if equipped)
- Electronic control unit (if equipped)
- Carburetor or fuel injection system
- Fuel lines (if equipped)
- Air filter, fuel filter, and spark plugs (only to first scheduled replacement point)

#### **LIMITATIONS**

This Emission Control System Warranty shall not cover any of the following:

- (a) repair or replacement required because of misuse or neglect, improper maintenance, repairs improperly performed or replacement not conforming to Kohler Co. specifications that adversely affect performance and/or durability and alterations or modifications not recommended or approved in writing by Kohler Co.,
- (b) replacement of parts and other services and adjustments necessary for required maintenance at and after the first scheduled replacement point,
- (c) consequential damages such as loss of time, inconvenience, loss of use of the engine or equipment, etc.,
- (d) diagnosis and inspection fees that do not result in eligible warranty service being performed, and
- (e) any add-on or modified part, or malfunction of authorized parts due to the use of add-on or modified parts.

#### **MAINTENANCE AND REPAIRS REQUIREMENTS**

The owner is responsible for the proper use and maintenance of the engine. Kohler Co. recommends that all receipts and records covering the performance of regular maintenance be retained in case questions arise. If the engine is resold during the warranty period, the maintenance records should be transferred to each subsequent owner. Kohler Co. reserves the right to deny warranty coverage if the engine has not been properly maintained; however, Kohler Co. may not deny warranty repairs solely because of the lack of repair maintenance or failure to keep maintenance records.

Normal maintenance, replacement or repair of emission control devices and systems may be performed by any repair establishment or individual; however, **warranty repair must be performed by a Kohler authorized service center.** Any replacement part or service that is equivalent in performance and durability may be used in non-warranty maintenance or repairs, and shall not reduce the warranty obligations of the engine manufacturer.

---

**CALIFORNIA EMISSION CONTROL WARRANTY STATEMENT  
YOUR WARRANTY RIGHTS AND OBLIGATIONS**

The California Air Resources Board and MTD Consumer Group Inc. are pleased to explain the evaporative emission control system warranty on your 2007 lawn mower. In California, new lawn mower must be designed, built and equipped to meet the State's stringent anti-smog standards. MTD Consumer Group Inc. must warrant the EECS on your lawn mower for the period of time listed below provided there has been no abuse, neglect or improper maintenance of your lawn mower.

Your EECS may include parts such as the carburetor, fuel-injection system, the ignition system, catalytic converter, fuel tanks, fuel lines, fuel caps, valves, canisters, filters, vapor hoses, clamps, connectors, and other associated emission-related components.

**Where a warrantable condition exists, MTD Consumer Group Inc. will repair your lawn mower at no cost to you including diagnosis, parts and labor.**

**MANUFACTURER'S WARRANTY COVERAGE:**

This evaporative emission control system is warranted for two years. If any evaporative emission-related part on your equipment is defective, the part will be repaired or replaced by MTD Consumer Group Inc.

**OWNER'S WARRANTY RESPONSIBILITIES:**

As the lawn mower owner, you are responsible for performance of the required maintenance listed in your owner's manual. MTD Consumer Group Inc. recommends that you retain all receipts covering maintenance on your lawn mower, but MTD Consumer Group Inc. cannot deny warranty solely for the lack of receipts.

As the lawn mower owner, you should however be aware that MTD Consumer Group Inc. may deny you warranty coverage if your lawn mower or a part has failed due to abuse, neglect, or improper maintenance or unapproved modifications.

You are responsible for presenting your lawn mower to MTD Consumer Group Inc's distribution center or service center as soon as the problem exists. The warranty repairs should be completed in a reasonable amount of time, not to exceed 30 days. If you have a question regarding your warranty coverage, you should contact the MTD Consumer Group Inc. Service Department at 1-800-800-7310.

**GENERAL EMISSIONS WARRANTY COVERAGE:**

MTD Consumer Group Inc. warrants to the ultimate purchaser and each subsequent purchaser that the lawn mower is: Designed, built and equipped so as to conform with all applicable regulations; and free from defects in materials and workmanship that cause the failure of a warranted part to be identical in all material respects to that part as described in MTD Consumer Group Inc's application for certification.

The warranty period begins on the date the lawn mower is delivered to an ultimate purchaser or first placed into service. The warranty period is two years.

Subject to certain conditions and exclusions as stated below, the warranty on emission-related parts is as follows:

1. Any warranted part that is not scheduled for replacement as required maintenance in the written instructions supplied, is warranted for the warranty period stated above. If the part fails during the period of warranty coverage, the part will be repaired or replaced by MTD Consumer Group Inc. according to subsection (4) below. Any such part repaired or replaced under warranty will be warranted for the remainder of the period.
2. Any warranted part that is scheduled only for regular inspection in the written instructions supplied is warranted for the warranty period stated above. Any such part repaired or replaced under warranty will be warranted for the remaining warranty period.
3. Any warranted part that is scheduled for replacement as required maintenance in the written instructions supplied is warranted for the period of time before the first scheduled replacement date for that part. If the part fails before the first scheduled replacement, the part will be repaired or replaced by MTD Consumer Group Inc. according to subsection (4) below. Any such part repaired or replaced under warranty will be warranted for the remainder of the period prior to the first scheduled replacement point for the part.
4. Repair or replacement of any warranted part under the warranty provisions herein must be performed at a warranty station at no charge to the owner.
5. Notwithstanding the provisions herein, warranty services or repairs will be provided at all of our distribution centers that are franchised to service the subject engines or equipment.
6. The lawn mower owner will not be charged for diagnostic labor that is directly associated with diagnosis of a defective, emission-related warranted part, provided that such diagnostic work is performed at a warranty station.
7. MTD Consumer Group Inc. is liable for damages to other engine or equipment components proximately caused by a failure under warranty of any warranted part.
8. Throughout the lawn mower warranty period stated above, MTD Consumer Group Inc. will maintain a supply of warranted parts sufficient to meet the expected demand for such parts.
9. Any replacement part may be used in the performance of any warranty maintenance or repairs and must be provided without charge to the owner. Such use will not reduce the warranty obligations of MTD Consumer Group Inc.
10. Add-on or modified parts that are not exempted by the Air Resources Board may not be used. The use of any non-exempted add-on or modified parts by the ultimate purchaser will be grounds for disallowing a warranty claim. MTD Consumer Group Inc. will not be liable to warrant failures of warranted parts caused by the use of a non-exempted add-on or modified part.

**WARRANTED PARTS:**

The repair or replacement of any warranted part otherwise eligible for warranty coverage may be excluded from such warranty coverage if MTD Consumer Group Inc. demonstrates that the lawn mower has been abused, neglected, or improperly maintained, and that such abuse, neglect, or improper maintenance was the direct cause of the need for repair or replacement of the part. That notwithstanding, any adjustment of a component that has a factory installed, and properly operating, adjustment limiting device is still eligible for warranty coverage. The following emission warranty parts list are covered: Fuel Line, Fuel Line Clamps.

## CUB CADET LLC MANUFACTURER'S LIMITED WARRANTY FOR RESIDENTIAL ZERO-TURN ("RZT") MOWERS

**IMPORTANT:** To obtain warranty coverage owner must present an original proof of purchase and applicable maintenance records to the servicing dealer. Please see the operator's manual for information on required maintenance and service intervals.

The limited warranty set forth below is given by Cub Cadet LLC with respect to new merchandise purchased or leased and used in the United States and/or its territories and possessions, and by MTD Products Limited with respect to new merchandise purchased or leased and used in Canada and/or its territories and possessions (either entity respectively, "Cub Cadet").

Cub Cadet warrants this product (excluding its *Normal Wear Parts, Batteries and Attachments* as described below) against defects in material and workmanship for a period of three (3) years or one hundred twenty (120) operation hours, whichever comes first, commencing on the date of original retail purchase or lease and will, at its option, repair or replace, free of charge, any part found to be defective in materials or workmanship.

*Normal Wear Parts* are warranted to be free from defects in material and workmanship for a period of thirty (30) days from the date of original purchase or lease. Normal wear parts include, but are not limited to items such as: belts, blades, blade adapters, grass bags, rider deck wheels, seats, and tires.

*Batteries* have a one-year prorated limited warranty against defects in material and workmanship, with 100% replacement during the first three months. After three months, the battery replacement credit is based on the months remaining in the twelve (12) month period dating back to the original date of original sale or lease. Any replacement battery will be warranted only for the remainder of the original warranty period.

*Attachments* — Cub Cadet warrants attachments for this product against defects in material and workmanship for a period of one (1) year, commencing on the date of the attachment's original purchase or lease. Attachments include, but are not limited to items such as: grass collectors and mulch kits.

This limited warranty shall only apply if this product has been operated and maintained in accordance with the Operator's Manual furnished with the product, and has not been subject to misuse, abuse, neglect, accident, improper maintenance, alteration, vandalism, theft, fire, water, or damage because of other peril or natural disaster. Damage resulting from the installation or use of any part, accessory or attachment not approved by Cub Cadet for use with the product(s) covered by this manual will void your warranty as to any resulting damage. In addition, Cub Cadet may deny warranty coverage if the hour meter, or any part thereof, is altered, modified, disconnected or otherwise tampered with.

**HOW TO OBTAIN SERVICE:** Warranty service is available, WITH PROOF OF PURCHASE AND APPLICABLE MAINTENANCE RECORDS, through your local authorized service dealer. To locate the dealer in your area:

**In the U.S.A.:**

Check your Yellow Pages, or contact Cub Cadet LLC at P.O. Box 361131, Cleveland, Ohio 44136-0019, call 1-877-282- 8684 or log on to our website at [www.cubcadet.com](http://www.cubcadet.com).

**In Canada:**

Contact MTD Products Limited, Kitchener, ON N2G 4J1, call 1-800-668-1238 or log on to our website at [www.mtdcanada.com](http://www.mtdcanada.com).

Without limiting the foregoing, this limited warranty does not provide coverage in the following cases:

- a. Routine maintenance items such as lubricants, filters, blade sharpening, tune-ups, brake adjustments, clutch adjustments, deck adjustments, and normal deterioration of the exterior finish due to use or exposure.
- b. Service completed by someone other than an authorized service dealer.
- c. Cub Cadet does not extend any warranty for products sold or exported outside of the United States and/or Canada, and their respective possessions and territories, except those sold through Cub Cadet's authorized channels of export distribution.
- d. Replacement parts and/or accessories that are not genuine Cub Cadet parts.
- e. Transportation charges and service calls.

**There are no implied warranties, including without limitation any implied warranty of merchantability or fitness for a particular purpose. No warranties shall apply after the applicable period of express written warranty above. No other express warranties beyond those mentioned above, given by any person or entity, including a dealer or retailer, with respect to any product, shall bind Cub Cadet. The exclusive remedy is repair or replacement of the product as set forth above. The terms of this warranty provide the sole and exclusive remedy arising from the sale and/or lease of the products covered hereby. Cub Cadet shall not be liable for any incidental or consequential loss or damage including, without limitation, expenses incurred for substitute or replacement lawn care services or for rental expenses to temporarily replace a warranted product.**

Some jurisdictions do not allow the exclusion or limitation of incidental or consequential damages, or limitations on how long an implied warranty lasts, so the above exclusions or limitations may not apply to you.

In no event shall recovery of any kind be greater than the amount of the purchase price of the product sold. **Alteration of safety features of the product shall void this warranty.** You assume the risk and liability for loss, damage, or injury to you and your property and/or to others and their property arising out of the misuse or inability to use the product.

This limited warranty shall not extend to anyone other than the original purchaser or to the person for whom it was purchased as a gift.

**HOW LOCAL LAWS RELATE TO THIS WARRANTY:** This limited warranty gives you specific legal rights, and you may also have other rights that vary in different jurisdictions.

**Cub Cadet LLC, P.O. BOX 361131 CLEVELAND, OHIO 44136-0019, Phone: 1-877-282-8684  
MTD Products Limited, Kitchener, ON N2G 4J1, Phone: 1-800-668-1238**