

Cub Cadet[®]

Operator's Manual

SERIES 1000

Hydrostatic Lawn Tractor

Models LT1042

LT1045

LT1046

LT1050

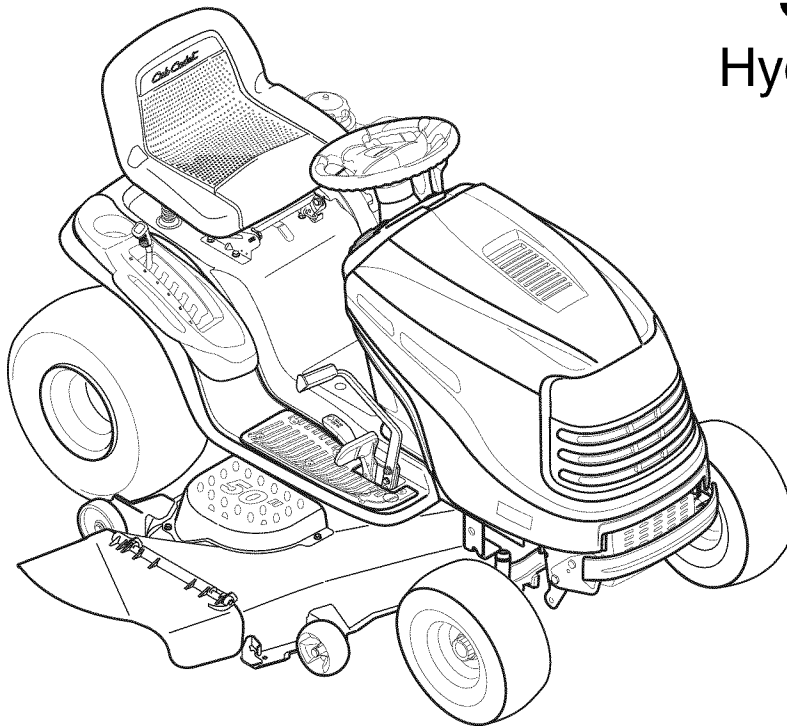

IMPORTANT: READ SAFETY RULES AND INSTRUCTIONS CAREFULLY

Warning: This unit is equipped with an internal combustion engine and should not be used on or near any unimproved forest-covered, brush-covered or grass-covered land unless the engine's exhaust system is equipped with a spark arrester meeting applicable local or state laws (if any). If a spark arrester is used, it should be maintained in effective working order by the operator. In the State of California the above is required by law (Section 4442 of the California Public Resources Code). Other states may have similar laws. Federal laws apply on federal lands. A spark arrester for the muffler is available through your Cub Cadet dealer or contact the service department, P.O. Box 361131 Cleveland, Ohio 44136-0019.

CUB CADET LLC, P.O. BOX 361131 CLEVELAND, OHIO 44136-0019

TABLE OF CONTENTS

Content	Page	Content	Page
Important Safe Operation Practices	3	Off-season Storage	30
Slope Gauge	7	Maintenance Schedule	30
Tractor Set-up	8	Maintenance Log	31
Know Your Lawn Tractor	9	Troubleshooting	32
Operating Your Lawn Tractor	12	Attachments & Accessories	33
Making Adjustments	17	Specifications	35
Maintaining Your Lawn Tractor	19	Replacement Parts	34
Service	25	Warranty Information	37

FINDING MODEL NUMBER

This Operator's Manual is an important part of your new lawn tractor. It will help you assemble, prepare and maintain the unit for best performance. Please read and understand what it says.



Before you start assembling your new equipment, please locate the model plate on the equipment and copy the information from it in the space provided below. A sample model plate is also illustrated below. You can locate the model plate by looking at the underside of the tractor's seat. This information will be necessary when contacting the *Cub Cadet Care Network* or your *Cub Cadet* dealer.

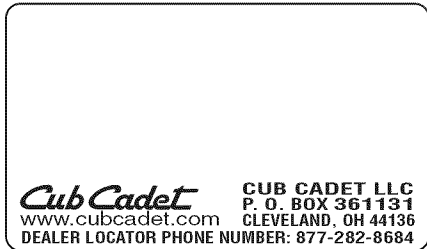

Copy the model number here: _____

Copy the serial number here: _____

CUSTOMER SUPPORT

Please do NOT return the unit to the retailer, without first contacting the Cub Cadet Care Network.

If you have difficulty assembling this product or have any questions regarding the controls, operation or maintenance of this unit, you can seek help from the experts. Choose from the options below:

	<p>Visit www.cubcadet.com for many useful suggestions. Click on Customer Service and help is immediately available.</p>
	<p>Call the <i>Cub Cadet Care Network</i> at (800) 965-4CUB.</p>

SECTION 1: IMPORTANT SAFE OPERATION PRACTICES



WARNING: This symbol points out important safety instructions which, if not followed, could endanger the personal safety and/or property of yourself and others. Read and follow all instructions in this manual before attempting to operate this machine. Failure to comply with these instructions may result in personal injury. When you see this symbol—heed its warning.



DANGER: This machine was built to be operated according to the rules for safe operation in this manual. As with any type of power equipment, carelessness or error on the part of the operator can result in serious injury. This machine is capable of amputating hands and feet and throwing objects. Failure to observe the following safety instructions could result in serious injury or death.

California Proposition 65 Warning:



WARNING: Engine exhaust, some of its constituents, and certain vehicle components contain or emit chemicals known to the State of California to cause cancer and birth defects or other reproductive harm.

GENERAL OPERATION

1. Read, understand, and follow all instructions on the machine and in the manual(s) before attempting to assemble and operate. Keep this manual in a safe place for future and regular reference and for ordering replacement parts.
2. Be familiar with all controls and their proper operation. Know how to stop the machine and disengage them quickly.
3. Never allow children under 14 years old to operate this machine. Children 14 years old and over should read and understand the operation instructions and safety rules in this manual and should be trained and supervised by a parent.
4. Never allow adults to operate this machine without proper instruction.
5. To help avoid blade contact or a thrown object injury, keep bystanders, helpers, children and pets at least 75 feet from the machine while it is in operation. Stop machine if anyone enters the area.
6. Thoroughly inspect the area where the equipment is to be used. Remove all stones, sticks, wire, bones, toys, and other foreign objects which could be picked up and thrown by the blade(s). Thrown objects can cause serious personal injury.
7. Plan your mowing pattern to avoid discharge of material toward roads, sidewalks, bystanders and the like. Also, avoid discharging material against a wall or obstruction which may cause discharged material to ricochet back toward the operator.
8. Always wear safety glasses or safety goggles during operation and while performing an adjustment or repair to protect your eyes. Thrown objects which ricochet can cause serious injury to the eyes.
9. Wear sturdy, rough-soled work shoes and close-fitting slacks and shirts. Loose fitting clothes and jewelry can be caught in movable parts. Never operate this machine in bare feet or sandals.
10. Be aware of the mower and attachment discharge direction and do not point it at anyone. Do not operate the mower without the discharge cover or entire grass catcher in its proper place.
11. Do not put hands or feet near rotating parts or under the cutting deck. Contact with the blade(s) can amputate hands and feet.
12. A missing or damaged discharge cover can cause blade contact or thrown object injuries.
13. Stop the blade(s) when crossing gravel drives, walks, or roads and while not cutting grass.
14. Watch for traffic when operating near or crossing roadways. This machine is not intended for use on any public roadway.
15. Do not operate the machine while under the influence of alcohol or drugs.
16. Mow only in daylight or good artificial light.
17. Never carry passengers.
18. Disengage blade(s) before shifting into reverse. Back up slowly. Always look down and behind before and while backing to avoid a back-over accident.
19. Slow down before turning. Operate the machine smoothly. Avoid erratic operation and excessive speed.
20. Disengage blade(s), set parking brake, stop engine and wait until the blade(s) come to a complete stop before removing grass catcher, emptying grass, unclogging chute, removing any grass or debris, or making any adjustments.
21. Never leave a running machine unattended. Always turn off blade(s), place transmission in neutral, set parking brake, stop engine and remove key before dismounting.
22. Use extra care when loading or unloading the machine into a trailer or truck. This unit should not be driven up or down ramp(s), because the unit could tip over, causing serious personal injury. The unit must be pushed manually on ramp(s) to load or unload properly.

23. Muffler and engine become hot and can cause a burn. Do not touch.
24. Check overhead clearances carefully before driving under low hanging tree branches, wires, door openings etc., where the operator may be struck or pulled from the unit, which could result in serious injury.
25. Disengage all attachment clutches, depress the brake pedal completely and shift into neutral before attempting to start engine.
26. Your machine is designed to cut normal residential grass of a height no more than 10". Do not attempt to mow through unusually tall, dry grass (e.g., pasture) or piles of dry leaves. Dry grass or leaves may contact the engine exhaust and/or build up on the mower deck presenting a potential fire hazard.
27. Use only accessories and attachments approved for this machine by the machine manufacturer. Read, understand and follow all instructions provided with the approved accessory or attachment.
28. Data indicates that operators, age 60 years and above, are involved in a large percentage of riding mower-related injuries. These operators should evaluate their ability to operate the riding mower safely enough to protect themselves and others from serious injury.
29. If situations occur which are not covered in this manual, use care and good judgment. Contact your *Cub Cadet* dealer for assistance.

SLOPE OPERATION

Slopes are a major factor related to loss of control and tip-over accidents which can result in severe injury or death. All slopes require extra caution. If you cannot back up the slope or if you feel uneasy on it, do not mow it.

For your safety, use the slope gauge included as part of this manual to measure slopes before operating this unit on a sloped or hilly area. If the slope is greater than 15 degrees as shown on the slope gauge, do not operate this unit on that area or serious injury could result.

DO:

1. Mow up and down slopes, not across. Exercise extreme caution when changing direction on slopes.
 2. Watch for holes, ruts, bumps, rocks, or other hidden objects. Uneven terrain could overturn the machine. Tall grass can hide obstacles.
 3. Use slow speed. Choose a low enough speed setting so that you will not have to stop or shift while on the slope. Tires may lose traction on slopes even though the brakes are functioning properly. Always keep machine in gear when going down slopes to take advantage of engine braking action.
4. Follow the manufacturer's recommendations for wheel weights or counterweights to improve stability.
 5. Use extra care with grass catchers or other attachments. These can change the stability of the machine.
 6. Keep all movement on the slopes slow and gradual. Do not make sudden changes in speed or direction. Rapid engagement or braking could cause the front of the machine to lift and rapidly flip over backwards which could cause serious injury.
 7. Avoid starting or stopping on a slope. If tires lose traction, disengage the blade(s) and proceed slowly straight down the slope.

DO NOT:

1. Do not turn on slopes unless necessary; then, turn slowly and gradually downhill, if possible.
2. Do not mow near drop-offs, ditches or embankments. The mower could suddenly turn over if a wheel is over the edge of a cliff, ditch, or if an edge caves in.
3. Do not try to stabilize the machine by putting your foot on the ground.
4. Do not use a grass catcher on steep slopes.
5. Do not mow on wet grass. Reduced traction could cause sliding.
6. Do not shift to neutral and coast downhill. Over-speeding may cause the operator to lose control of the machine resulting in serious injury or death.
7. Do not tow heavy pull behind attachments (e.g. loaded dump cart, lawn roller, etc.) on slopes greater than 5 degrees. When going down hill, the extra weight tends to push the tractor and may cause you to lose control. (e.g. tractor may speed up, braking and steering ability are reduced, attachment may jack-knife and cause tractor to overturn).

CHILDREN

1. Tragic accidents can occur if the operator is not alert to the presence of children. Children are often attracted to the machine and the mowing activity. They do not understand the dangers. Never assume that children will remain where you last saw them.
 - a. Keep children out of the mowing area and in watchful care of a responsible adult other than the operator.
 - b. Be alert and turn machine off if a child enters the area.
 - c. Before and while backing, look behind and down for small children.
 - d. Never carry children, even with the blade(s) shut off. They may fall off and be seriously injured or interfere with safe machine operation.

- e. Use extreme care when approaching blind corners, doorways, shrubs, trees or other objects that may block your vision of a child who may run into the machine.
 - f. **To avoid back-over accidents, always disengage the cutting blade(s) before shifting into reverse. The “Reverse Caution Mode” should not be used when children or others are around.**
 - g. Keep children away from hot or running engines. They can suffer burns from a hot muffler.
 - h. Remove key when machine is unattended to prevent unauthorized operation.
9. Never allow children under 14 years old to operate the machine. Children 14 years old and over should read and understand the operation instructions and safety rules in this manual and should be trained and supervised by a parent.

TOWING

1. Tow only with a machine that has a hitch designed for towing. Do not attach towed equipment except at the hitch point.
2. Follow the manufacturers recommendation for weight limits for towed equipment and towing on slopes.
3. Never allow children or others in or on towed equipment.
4. On slopes, the weight of the towed equipment may cause loss of traction and loss of control.
5. Travel slowly and allow extra distance to stop.
6. Do not shift to neutral and coast downhill.

SERVICE

SAFE HANDLING OF GASOLINE:

1. **To avoid personal injury or property damage** use extreme care in handling gasoline. Gasoline is extremely flammable and the vapors are explosive. Serious personal injury can occur when gasoline is spilled on yourself or your clothes which can ignite. Wash your skin and change clothes immediately.
 - a. Use only an approved gasoline container.
 - b. Never fill containers inside a vehicle or on a truck or trailer bed with a plastic liner. Always place containers on the ground away from your vehicle before filling.
 - c. When practical, remove gas-powered equipment from the truck or trailer and refuel it on the ground. If this is not possible, then refuel such equipment on a trailer with a portable container, rather than from a gasoline dispenser nozzle.
 - d. Keep the nozzle in contact with the rim of the fuel tank or container opening at all times until fueling is complete. Do not use a nozzle

- lock-open device.
- e. Extinguish all cigarettes, cigars, pipes and other sources of ignition.
- f. Never fuel machine indoors.
- g. Never remove gas cap or add fuel while the engine is hot or running. Allow engine to cool at least two minutes before refueling.
- h. Never over fill fuel tank. Fill tank to no more than ½ inch below bottom of filler neck to allow space for fuel expansion.
- i. Replace gasoline cap and tighten securely.
- j. If gasoline is spilled, wipe it off the engine and equipment. Move unit to another area. Wait 5 minutes before starting the engine.
- k. To reduce fire hazards, keep machine free of grass, leaves, or other debris build-up. Clean up oil or fuel spillage and remove any fuel soaked debris.
- l. Never store the machine or fuel container inside where there is an open flame, spark or pilot light as on a water heater, space heater, furnace, clothes dryer or other gas appliances.
- m. Allow a machine to cool at least 5 minutes before storing.

GENERAL SERVICE:

1. Never run an engine indoors or in a poorly ventilated area. Engine exhaust contains carbon monoxide, an odorless, and deadly gas.
2. Before cleaning, repairing, or inspecting, make certain the blade(s) and all moving parts have stopped. Disconnect the spark plug wire and ground against the engine to prevent unintended starting.
3. Periodically check to make sure the blades come to complete stop within approximately (5) five seconds after operating the blade disengagement control. If the blades do not stop within the this time frame, your unit should be serviced professionally by your *Cub Cadet* dealer.
4. Check brake operation frequently as it is subjected to wear during normal operation. Adjust and service as required.
5. Check the blade(s) and engine mounting bolts at frequent intervals for proper tightness. Also, visually inspect blade(s) for damage (e.g., excessive wear, bent, cracked). Replace the blade(s) with the original equipment manufacturer’s (O.E.M.) blade(s) only, listed in this manual. “Use of parts which do not meet the original equipment specifications may lead to improper performance and compromise safety!”
6. Mower blades are sharp. Wrap the blade or wear gloves, and use extra caution when servicing them.
7. Keep all nuts, bolts, and screws tight to be sure the equipment is in safe working condition.

8. Never tamper with the safety interlock system or other safety devices. Check their proper operation regularly.
9. After striking a foreign object, stop the engine, disconnect the spark plug wire(s) and ground against the engine. Thoroughly inspect the machine for any damage. Repair the damage before starting and operating.
10. Never attempt to make adjustments or repairs to the machine while the engine is running.
11. Grass catcher components and the discharge cover are subject to wear and damage which could expose moving parts or allow objects to be thrown.

For safety protection, frequently check components and replace immediately with original equipment manufacturer's (O.E.M.) parts only, listed in this manual. "Use of parts which do not meet the original equipment specifications may lead to improper performance and compromise safety!"

12. Do not change the engine governor settings or over-speed the engine. The governor controls the maximum safe operating speed of the engine.
13. Maintain or replace safety and instruction labels, as necessary.
14. Observe proper disposal laws and regulations for gas, oil, etc. to protect the environment.



WARNING: YOUR RESPONSIBILITY Restrict the use of this power machine to persons who read, understand and follow the warnings and instructions in this manual and on the machine.



⚠ DANGER

ROTATING BLADES CAUSE
 SERIOUS INJURY OR DEATH

- DO NOT MOW WHEN CHILDREN OR OTHERS ARE AROUND
- NEVER CARRY CHILDREN EVEN WITH BLADE(S) OFF.
- LOOK DOWN AND BEHIND BEFORE AND WHILE BACKING.
- MOWING IN REVERSE IS NOT RECOMMENDED.

⚠ WARNING

TO AVOID SERIOUS INJURY OR DEATH

- GO UP AND DOWN SLOPES, NOT ACROSS.
- AVOID SUDDEN TURNS.
- DO NOT OPERATE THE UNIT WHERE IT COULD SLIP OR TIP.
- IF MACHINE STOPS GOING UPHILL, STOP BLADE(S) AND BACK DOWNHILL SLOWLY.
- KEEP SAFETY DEVICES (GUARDS, SHIELDS, AND SWITCHES, ETC.) IN PLACE AND WORKING.
- REMOVE OBJECTS THAT COULD BE THROWN BY THE BLADE(S).
- KNOW LOCATION AND FUNCTION OF ALL CONTROLS.
- BE SURE BLADE(S) AND ENGINE ARE STOPPED BEFORE PLACING HANDS OR FEET NEAR BLADE(S).
- BEFORE LEAVING OPERATOR'S POSITION, DISENGAGE BLADE(S), ENGAGE PARKING BRAKE, SHUT OFF AND REMOVE KEY.

READ OPERATOR'S MANUAL

SECTION 2: SLOPE GAUGE

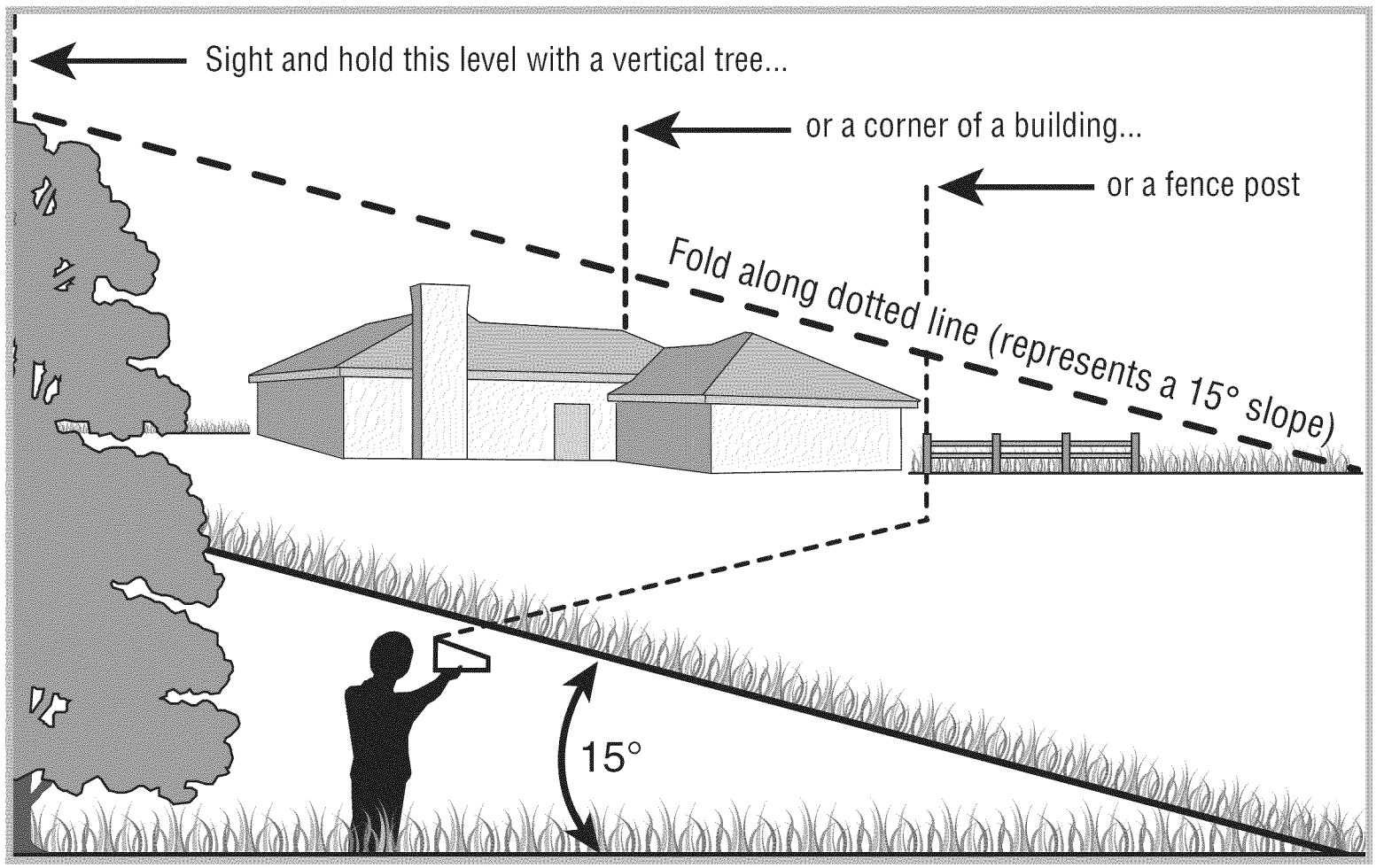

SECTION 3: TRACTOR SET-UP

Shipping Brace Removal



WARNING: Make sure the riding mower's engine is off, set the parking brake and remove the ignition key before removing the shipping brace.

- Locate the shipping brace, if present, and warning tag found on the right side of the cutting deck.
- While holding the discharge chute with your left hand, remove the shipping brace with your right hand by grasping it between your thumb and index finger and rotating it clockwise.



WARNING: The shipping brace, used for packaging purposes only, must be removed and discarded before operating your riding mower.



WARNING: The mowing deck is capable of throwing objects. Failure to operate the riding mower without the discharge cover in the proper operating position could result in serious personal injury and/or property damage.

Tire Pressure



WARNING: Maximum tire pressure under any circumstances is 30 psi. Equal tire pressure should be maintained at all times.

The tires on your unit may be over-inflated for shipping purposes. Reduce the tire pressure before operating the tractor. Recommended operating tire pressure is approximately 10 p.s.i. for the rear tires & 14 p.s.i. for the front tires. Check sidewall of tire for maximum p.s.i.

Attaching the Battery Cables

NOTE: *The positive battery terminal is marked Pos. (+). The negative battery terminal is marked Neg. (-).*

- The positive cable (heavy red wire) is secured to the positive battery terminal (+) with a hex bolt and hex nut at the factory. Make certain that the red rubber boot covers the terminal to help protect it from corrosion.
- Remove the carriage bolt and hex nut from the negative cable.
- Remove the black plastic cover, if present, from the negative battery terminal and attach the negative cable (heavy black wire) to the negative battery terminal (-) with the bolt and hex nut.
- Make certain the hold-down rod is in position over the battery, securing it in place.

NOTE: *If the battery is put into service after the date shown on top/side of battery, charge the battery as instructed on page 26 of this manual prior to operating the tractor.*

Gas and Oil Fill-up

The gasoline tank is located under the fender and has a capacity of three and-a-half gallons. Remove the fuel cap by turning it counterclockwise. Use only clean, fresh (no more than 30 days old), unleaded gasoline. Fill the tank no higher than four inches below the top of the filler neck to allow space for fuel expansion.



WARNING: Use extreme care when handling gasoline. Gasoline is extremely flammable and the vapors are explosive. Never fuel machine indoors or while the engine is hot or running. Extinguish cigarettes, cigars, pipes, and other sources of ignition.

IMPORTANT: Your tractor is shipped with oil in the engine. However, you **MUST** check the oil level before operating. Refer to **Checking the Oil Level** on page 19 for detailed instructions. Be careful not to overfill.

SECTION 4: KNOW YOUR LAWN TRACTOR

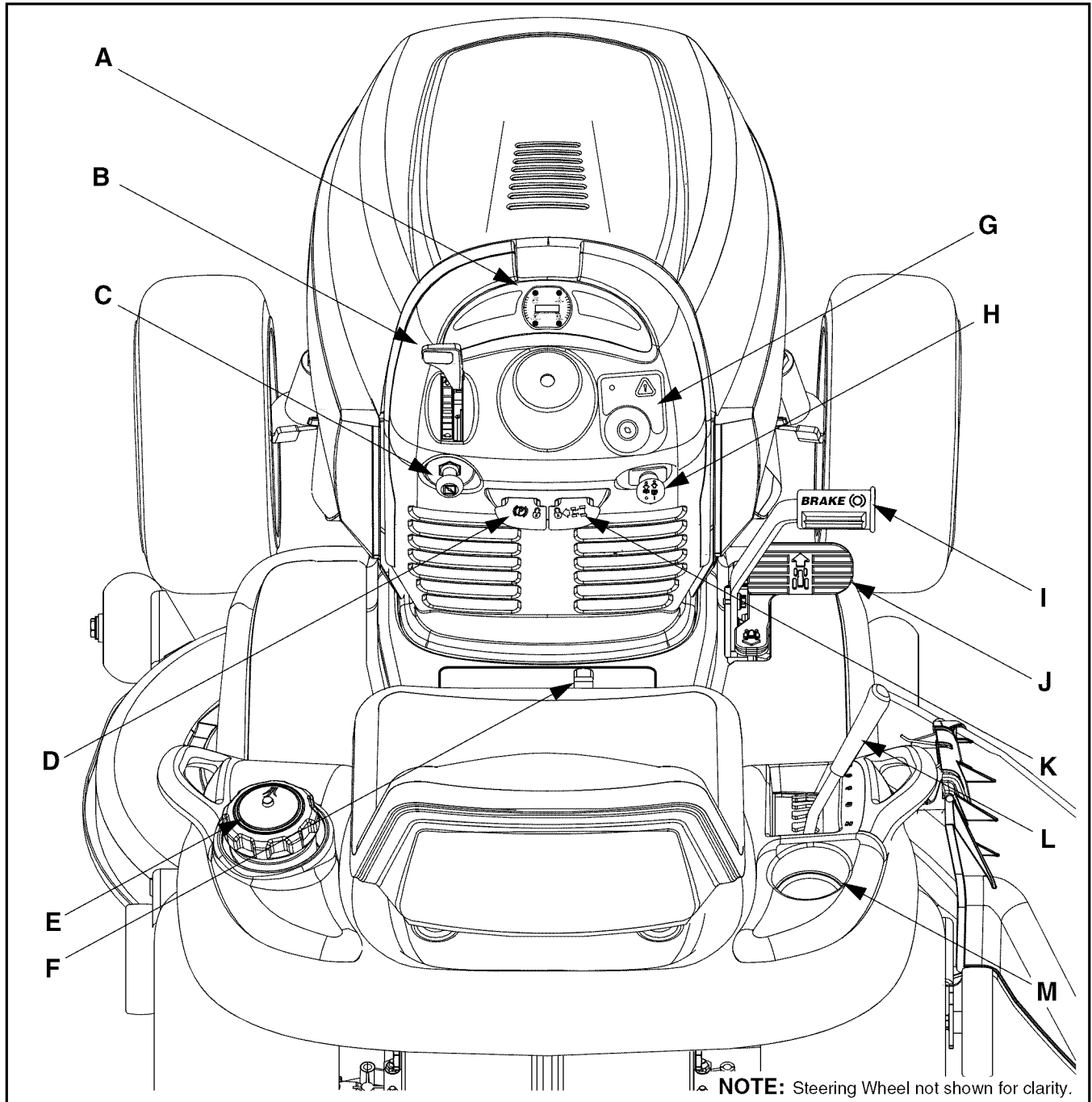

Figure 1

- | | |
|---|----------------------------------|
| A Systems Indicator Monitor/Hour Meter | H PTO (Blade Engage) Knob |
| B Throttle Control Lever | I Brake Pedal |
| C Choke Control | J Drive Pedal |
| D Parking Brake Lever | K Cruise Control Lever |
| E Fuel Tank Cap | L Deck Lift Lever |
| F Seat Adjustment Lever | M Cup Holder |
| G Ignition Switch Module | |

NOTE: Any reference in this manual to the RIGHT or LEFT side of the tractor is observed from operator's position.

Throttle Control Lever

The throttle control lever is located on the left side of the tractor's dash panel. This lever controls the speed of the engine. When set in a given position, the throttle will maintain a uniform engine speed.

IMPORTANT: When operating the tractor with the cutting deck engaged, be certain that the throttle lever is **always** in the FAST (rabbit) position.

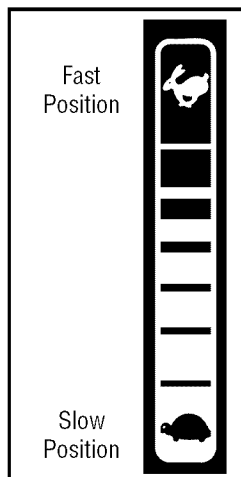

Choke Control

The choke control can be found on the left side of the dash panel and is activated by pulling the knob outward. Activating the choke control closes the choke plate on the carburetor and aids in starting the engine. Refer to **Starting The Engine** on page 13 of this manual for detailed starting instructions.

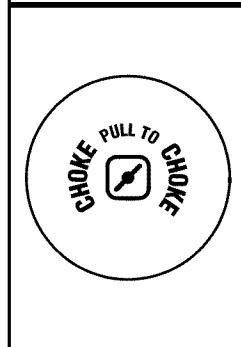

Brake Pedal

The brake pedal is located on the right front side of the tractor above the drive pedal along the running board. The brake pedal can be used for sudden stops or setting the parking brake.

NOTE: The brake pedal must be fully depressed to activate the safety interlock switch when starting the tractor.

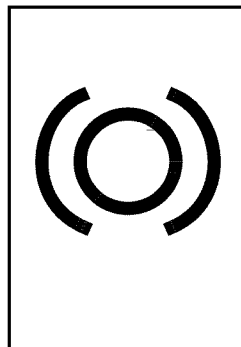

Seat Adjustment Lever

To adjust the seat forward or backward, slide the seat adjustment lever to the left and reposition the seat to the desired position. Once a comfortable position is found, release the seat adjustment lever to lock the seat in place. Refer to **Seat Adjustment** on page 18 of this manual for more detailed instructions.

Deck Lift Lever

Found on your tractor's right fender, the deck lift lever is used to change the height of the cutting deck. To use, move the lever to the left, then place in the notch best suited for your application.

Ignition Switch Module



WARNING: Never leave a running machine unattended. Always disengage PTO, move shift lever into neutral position, set parking brake, stop engine and remove key to prevent unintended starting.

To start the engine, insert the key into the ignition switch and turn clockwise to the **START** position. Release the key into the **NORMAL MOWING MODE** position once the engine has fired.

To stop the engine, turn the ignition key counterclockwise to the **STOP** position. See Figure 2.

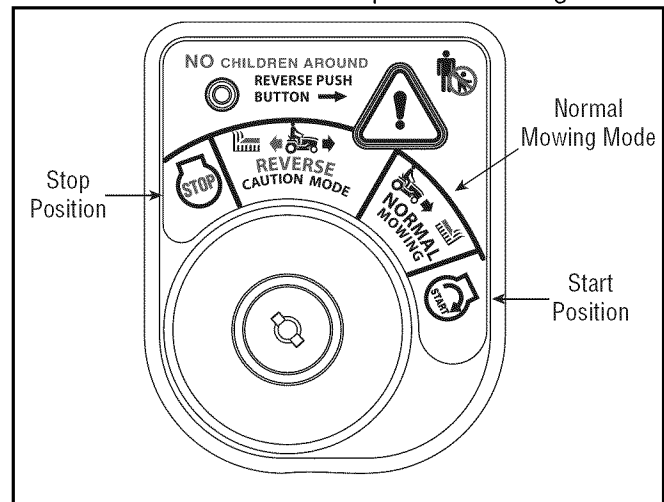

Figure 2

IMPORTANT: Prior to operating the tractor, refer to both **Safety Interlock Switches** on page 12 and **Starting The Engine** on page 13 of this manual for detailed instructions regarding the Ignition Switch Module and operating the tractor in **REVERSE CAUTION MODE**.

Drive Pedal

The drive pedal is located on the right side of the tractor, along the running board. Press the upper portion of the drive pedal forward to cause the tractor to travel forward. Press the lower portion of the drive pedal with the ball of your right foot (NOT your heel) to cause the tractor to travel in reverse. Ground speed is also controlled with the drive pedal. The further forward or rearward that the pedal is pivoted, the faster the tractor will travel. The pedal will return to its original position when it's not pressed.

IMPORTANT: Always set the parking brake when leaving the tractor unattended.

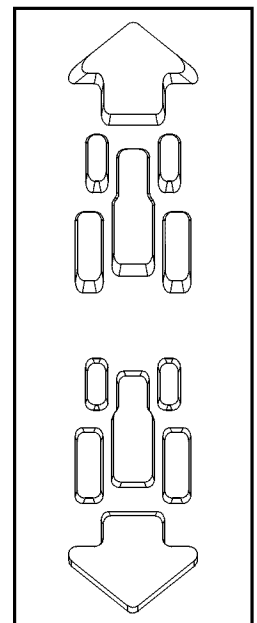

Systems Indicator Monitor / Hour Meter

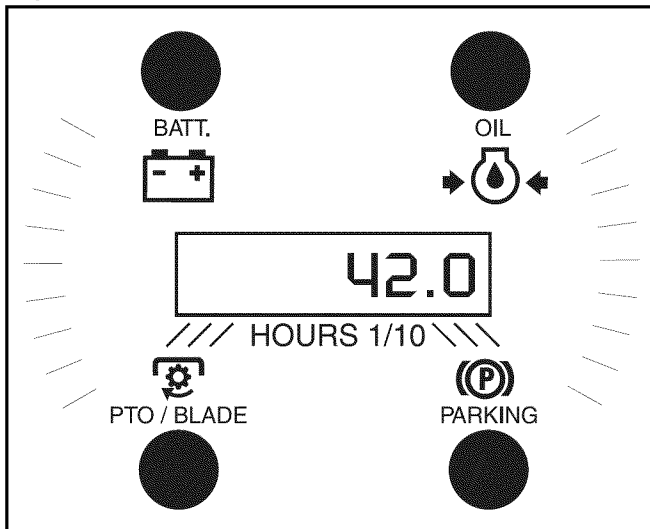

LCD

Located in the center of the tractor's console, the systems indicator monitor records, and displays on its LCD, hours of tractor operation whenever the ignition key is rotated out of the STOP position.

The Indicator Monitor will also remind the operator of maintenance intervals for changing the engine oil. The LCD will alternately flash the recorded hours, "CHG" and "OIL" for five minutes, after every 50 hours of recorded operation elapse. The maintenance interval lasts for two hours (from 50-52, 100-102, 150-152, etc.). The LCD will also flash as described above for five minutes every time the tractor's engine has been started during this maintenance interval. Before the interval expires, change the crankcase oil level as instructed in this Operator's Manual.

Brake

If the Brake light illuminates when attempting to start the tractor's engine, depress the brake pedal.

PTO (Blade Engage)

If the PTO light illuminates when attempting to start the tractor's engine, move PTO lever into the disengaged (OFF) position.

Oil

It is normal for the Oil light to illuminate while the engine is **cranking** during start-up, but if it illuminates during operation, **while the engine is running**, stop the tractor immediately and check the engine oil level as instructed in this Owner's Manual.

Battery

It is normal for the Battery light to illuminate while the engine is **cranking** during start-up, but if it illuminates during operation, **while the engine is running**, the battery is in need of a charge or the engine's charging system is not generating sufficient amperage. Charge the battery as instructed on page 26 of this manual or have the charging system checked by your *Cub Cadet* dealer.

Electric PTO / Blade Engage Knob

To engage the power to the cutting deck or other (separately available) attachments, pull outward on the PTO/Blade Engage knob. Push the PTO/Blade Engage knob inward to disengage the power to the cutting deck or other (separately available) attachments.

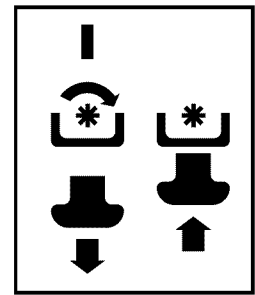

NOTE: The PTO/Blade Engage knob **must** be in the disengaged (OFF) position when starting the engine.

Cruise Control Lever

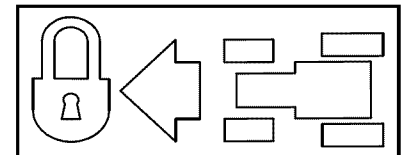

The cruise control lever is located on the tractor dash

below the steering wheel. Push the cruise control lever downward while traveling forward at a desired speed. While holding the lever down, release pressure from the drive pedal.

This will engage the cruise control and allow the tractor to remain at that speed without applying pressure to the drive pedal. Press the brake pedal or the drive pedal to deactivate cruise control. Refer to page 14 for detailed instructions regarding the cruise control feature.

NOTE: Cruise control can **NOT** be engaged at the tractor's fastest ground speed. If the operator should attempt to do so, the tractor will automatically decelerate to the fastest optimal mowing ground speed.

Parking Brake Lever

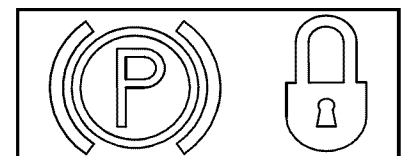

To set the parking brake, fully depress the brake pedal and

push the parking brake lever down. Hold the lever down while taking your foot off the brake pedal. Both the parking lever and the brake pedal will then stay depressed. To release the parking brake, depress the brake pedal slightly. The parking brake lever will then return to its original position.

NOTE: The parking brake must be set if the operator leaves the seat with the engine running or the engine will automatically shut off.

IMPORTANT: Always set the parking brake when leaving the tractor unattended.

SECTION 5: OPERATING YOUR LAWN TRACTOR



WARNING

AVOID SERIOUS INJURY OR DEATH

- GO UP AND DOWN SLOPES, NOT ACROSS.
- AVOID SUDDEN TURNS.
- DO NOT OPERATE THE UNIT WHERE IT COULD SLIP OR TIP.
- IF MACHINE STOPS GOING UPHILL, STOP BLADE(S) AND BACK DOWNHILL SLOWLY.
- DO NOT MOW WHEN CHILDREN OR OTHERS ARE AROUND.
- NEVER CARRY CHILDREN, EVEN WITH BLADES OFF.
- LOOK DOWN AND BEHIND BEFORE AND WHILE BACKING.
- KEEP SAFETY DEVICES (GUARDS, SHIELDS, AND SWITCHES) IN PLACE AND WORKING.
- REMOVE OBJECTS THAT COULD BE THROWN BY THE BLADE(S).
- KNOW LOCATION AND FUNCTION OF ALL CONTROLS.
- BE SURE BLADE(S) AND ENGINE ARE STOPPED BEFORE PLACING HANDS OR FEET NEAR BLADE(S).
- BEFORE LEAVING OPERATOR'S POSITION, DISENGAGE BLADE(S), PLACE THE SHIFT LEVER IN NEUTRAL, ENGAGE BRAKE LOCK, SHUT ENGINE OFF AND REMOVE KEY.

READ OPERATOR'S MANUAL

Safety Interlock Switches

This tractor is equipped with a safety interlock system for the protection of the operator. If the interlock system should ever malfunction, do not operate the tractor. Contact your *Cub Cadet* dealer.

- The safety interlock system prevents the engine from cranking or starting unless the parking brake is engaged, and the PTO (Blade Engage) knob is in the disengaged (OFF) position.
- The engine will automatically shut off if the operator leaves the seat before engaging the parking brake.
- The electric PTO (Blade Engage) clutch will automatically shut off if the operator leaves the tractor's seat with the PTO (Blade Engage) knob in the engaged (ON) position, regardless of whether the parking brake is engaged.
- With the ignition key in the **NORMAL MOWING** position, the electric PTO (Blade Engage) clutch will automatically shut off if the PTO (Blade Engage) knob is moved into the engaged (ON) position with the drive pedal in position for Reverse travel.



WARNING: Do not operate the tractor if the interlock system is malfunctioning. This system was designed for your safety and protection.

Reverse Caution Mode

The **REVERSE CAUTION MODE** position of the key switch module allows the tractor to be operated in reverse with the blades (PTO) engaged.

IMPORTANT: *Mowing in reverse is not recommended.*



WARNING: Use extreme caution while operating the tractor in the **REVERSE CAUTION MODE**. Always look down and behind before and while backing. Do not operate the tractor when children or others are around. Stop the tractor immediately if someone enters the area.

To use the **REVERSE CAUTION MODE**:

IMPORTANT: *The operator MUST be seated in the tractor seat.*

1. Start the engine as previously instructed in this Operator's Manual.
2. Turn the key from the **NORMAL MOWING** (Green) position to the **REVERSE CAUTION MODE** (Yellow) position of the key switch module. See Figure 3.
3. Depress the **REVERSE PUSH BUTTON** (Orange, Triangular Button) at the top, right corner of the key switch module. The red indicator light at the top, left corner of the key switch module will be **ON** while activated. See Figure 3.
4. Once activated (indicator light **ON**), the tractor can be driven in reverse with the cutting blades (PTO) engaged.
5. Always look down and behind before and while backing to make sure no children are around.
6. After resuming forward motion, return the key to the **NORMAL MOWING** position.

IMPORTANT: The **REVERSE CAUTION MODE** will remain activated until:

- a. The key is placed in either the **NORMAL MOWING** position or **STOP** position.
- b. The operator leaves the seat.

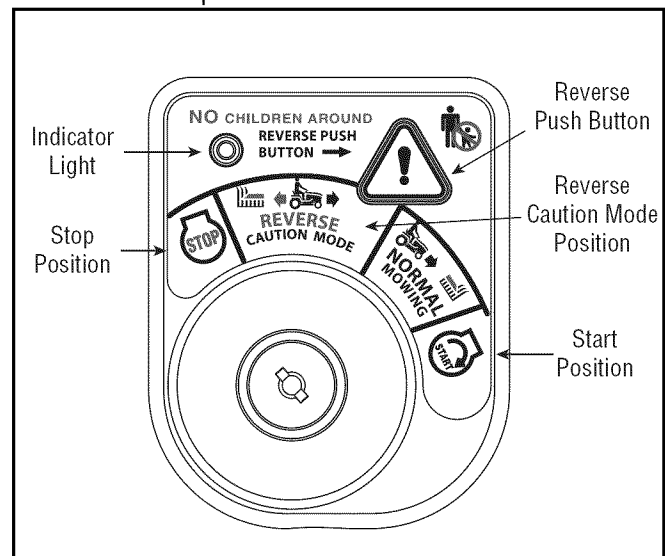

Figure 3

Setting the Gauge Wheels

Select the height position of the cutting deck by placing the deck lift lever in any of the six different cutting height notches on the right fender.

Adjust the deck wheels so that they are between ¼-inch and ½-inch above the ground as follows.



WARNING: Keep hands and feet away from the discharge opening of the cutting deck.

Place the tractor on a firm and level surface, preferably pavement. Refer to Figure 4, and proceed as follows:

- Place the tractor's deck lift handle in the normally desired mowing height setting, then check the gauge wheels for contact or excessive clearance with the surface below.

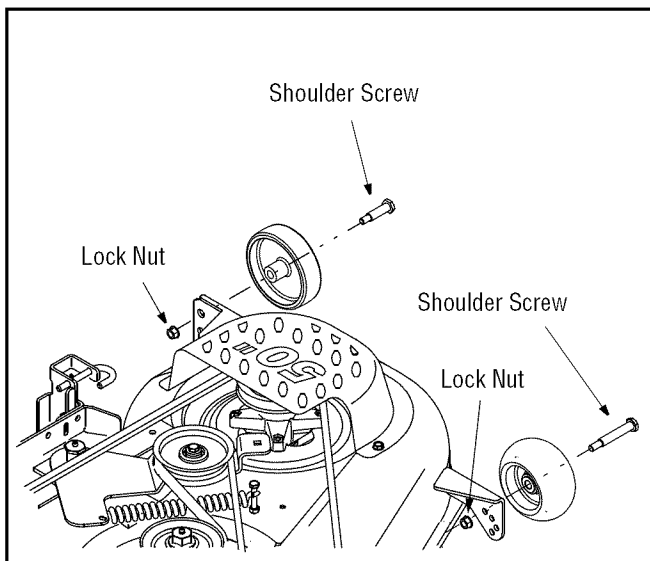

Figure 4

- If the wheels contact the surface adjust as follows:
 - a. Raise the deck lift handle to its highest setting.
 - b. Remove the rear gauge wheels by removing the lock nuts and shoulder screws which secure them to the deck.
 - c. Remove the lock nuts and shoulder screws which secure the front gauge wheels to the deck.
 - d. Place the deck lift handle in the desired mowing height setting.
 - e. Insert the shoulder screw with the rear gauge wheel into the index hole that leaves approximately 1/2" between the bottom of the wheel and the pavement.
 - f. Note the position of the index hole used; then install the other rear gauge wheel and the front ball wheels into the corresponding index hole of the other gauge wheel brackets.

- If the gauge wheels have excessive clearance with the surface below, lower the wheels to the index hole that provides the approximate 1/2" clearance as described above.

Refer to **Leveling the Deck** on page 17 of this manual for more detailed instructions regarding various deck adjustments.

Starting the Engine



WARNING: Do not operate the tractor if the interlock system is malfunctioning. This system was designed for your safety and protection.

NOTE: Refer to the **TRACTOR SET-UP** on page 8 of this manual for Gasoline and Oil fill-up instructions.

- Insert the tractor key into the ignition switch module.
- Place the PTO (Blade Engage) knob in the disengaged (OFF) position.
- Engage the tractor's parking brake.
- Activate the choke control.
- Turn the ignition key clockwise to the START position. After the engine starts, release the key. It will return to the **NORMAL MOWING** position.

IMPORTANT: Do NOT hold the key in the START position for longer than ten seconds at a time. Doing so may cause damage to your engine's electric starter.

- After the engine starts, deactivate the choke control.

NOTE: Do NOT leave the choke control on while operating the tractor. Doing so will result in a "rich" fuel mixture and cause the engine to run poorly.

Stopping the Engine



WARNING: If you strike a foreign object, stop the engine and disconnect the spark plug wire(s). Thoroughly inspect the machine for any damage. Repair the damage before restarting and operating

- If the blades are engaged, place the PTO/Blade Engage knob in the disengaged (OFF) position.
- Place the throttle control near the FAST position
- Turn the ignition key counterclockwise to the STOP position.
- Remove the key from the ignition switch to prevent unintended starting.

Engaging the Parking Brake

To engage the parking brake:

- Fully depress the brake pedal and hold it while gently pushing the parking brake lever downward.
- Hold the parking brake lever down while removing your foot from the brake pedal.
- Once engaged, the parking brake lever and the brake pedal will lock in the “down” position.

To disengage the parking brake:

- Slightly depress the brake pedal.

NOTE: *The parking brake must be engaged if the operator leaves the seat with the engine running or the engine will automatically shut off.*

Driving The Tractor



WARNING: Avoid sudden starts, excessive speed and sudden stops.



WARNING: Do not leave the seat of the tractor without first placing the PTO/Blade Engage knob in the disengaged (OFF) position, pressing the brake pedal and engaging the parking brake. If leaving the tractor unattended, also turn the ignition key off and remove the key.

- Briefly depress the brake pedal to release the parking brake. Move the throttle lever into the FAST (rabbit) position.
- To travel FORWARD, slowly depress the upper portion of the drive pedal forward until the desired speed is achieved. See Figure 5.

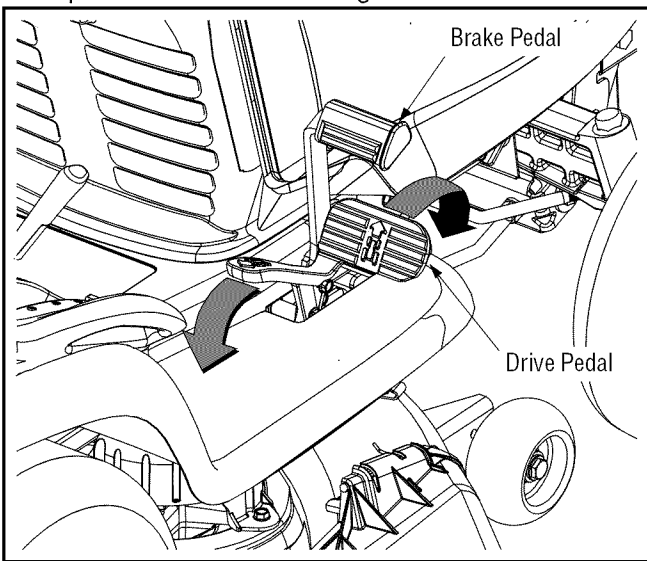

Figure 5

- To travel in REVERSE, check that the area behind is clear then slowly depress the lower portion of the drive pedal with the ball of your foot (NOT your heel) until the desired speed is achieved. See Figure 5.

IMPORTANT: Do NOT attempt to change the direction of travel when the tractor is in motion. Always bring the tractor to a **complete** stop before pivoting the drive pedal from forward to reverse or vice versa.

Driving On Slopes

Refer to the **SLOPE GAUGE** on page 7 to help determine slopes where you may operate the tractor safely.



WARNING: Do not mow on inclines with a slope in excess of 15 degrees (a rise of approximately 2-1/2 feet every 10 feet). The tractor could overturn and cause serious injury.

- Mow up and down slopes, NEVER across.
- Exercise extreme caution when changing direction on slopes.
- Watch for holes, ruts, bumps, rocks, or other hidden objects. Uneven terrain could overturn the machine. Tall grass can hide obstacles.
- Avoid turns when driving on a slope. If a turn must be made, turn down the slope. Turning up a slope greatly increases the chance of a roll over.
- Avoid stopping when driving up a slope. If it is necessary to stop while driving up a slope, start up smoothly and carefully to reduce the possibility of flipping the tractor over backward.

Setting The Cruise Control

NOTE: *The cruise control feature should only be utilized while traveling in the forward direction.*

- Slowly press the upper portion of the drive pedal until the desired speed is achieved.
- Lightly press the cruise control lever.
- While continuing to hold the cruise lever down, lift your foot from the drive pedal (you should feel the cruise latch engage).
- Once engaged, the cruise control lever and the drive pedal will lock in the “down” position, and the tractor will maintain the same forward speed.

NOTE: *Cruise control can not be set at the tractor's fastest ground speed. If the operator should attempt to do so, the tractor will automatically decelerate to the fastest optimal mowing ground speed.*

Disengage the cruise control using one of the following methods:

- Depress the brake pedal to disengage the cruise control and stop the tractor.
- Lightly depress the drive pedal.

To change the direction of travel to reverse when operating with cruise control, depress the brake pedal to disengage the cruise control and bring the tractor to a complete stop. Then slowly depress the rear portion of the drive pedal with the ball of your foot to travel in reverse.

Using the Deck Lift Lever

To raise the cutting deck, move the deck lift lever to the left, then place it in the notch best suited for your application. Refer to **Setting The Cutting Height** earlier in this section.

Operating the Headlights

The lamps are ON whenever the ignition key is moved out of the STOP position. The lamps turn OFF when the ignition key is moved to the STOP position.

Moving The Tractor Manually

Your tractor's transmission is equipped with a hydrostatic relief valve for occasions when it is necessary to move the tractor manually. Opening this valve permits the fluid in the transmission to bypass its normal route, allowing the rear tires to "freewheel." To open the hydrostatic relief valve, proceed as follows:

- Locate the hydrostatic bypass rod in the rear of the tractor. See Figure 6.

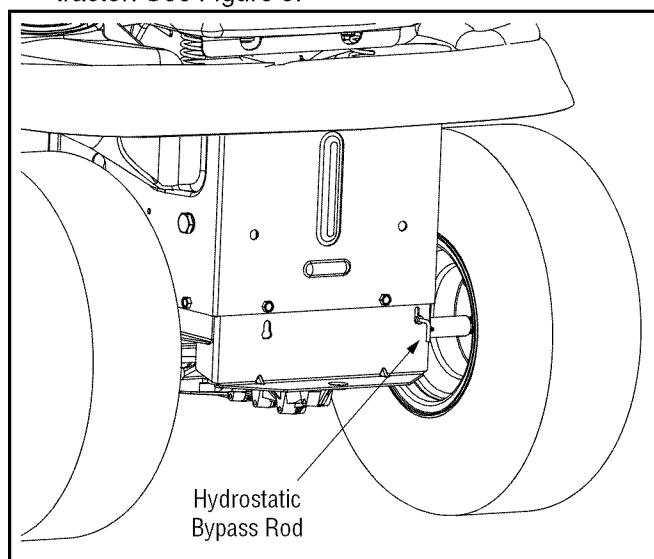

Figure 6

- Pull the hydrostatic bypass rod outward, then down, to lock it in place.

NOTE: The transmission will NOT engage when the hydrostatic bypass rod is pulled out. Return the rod to its normal position prior to operating the tractor.

IMPORTANT: Never attempt to move the tractor manually without first opening the hydrostatic relief valve. Doing so will result in serious damage to the tractor's transmission.

Engaging the PTO

Engaging the PTO transfers power to the cutting deck or other (separately available) attachments. To engage the PTO, proceed as follows:

- Move the throttle control lever to the FAST (rabbit) position.
- Pull the PTO/Blade Engage knob outward into the engaged (ON) position. See Figure 7.
- Keep the throttle lever in the FAST (rabbit) position for the most efficient use of the cutting deck or other (separately available) attachments.

IMPORTANT: The electric PTO clutch will automatically shut off if the PTO is engaged with the drive pedal in position for reverse travel. Refer to **Safety Interlock Switches** on page 12.

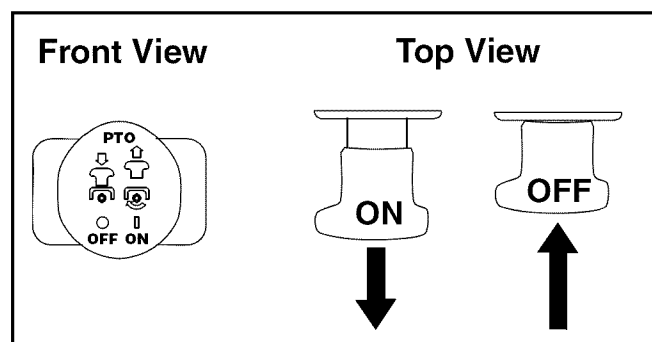

Figure 7

Mowing



WARNING: To help avoid blade contact or a thrown object injury, keep bystanders, helpers, children and pets at least 75 feet from the machine while it is in operation. Stop machine if anyone enters the area.

The following information will be helpful when using the cutting deck with your tractor.



WARNING: Plan your mowing pattern to avoid discharge of materials toward roads, sidewalks, bystanders and the like. Also, avoid discharging material against a wall or obstruction which may cause discharged material to ricochet back toward the operator.

- Do not mow at high ground speed, especially if a mulch kit or grass collector is installed.
- Do not cut the grass too short. Short grass invites weed growth and yellows quickly in dry weather.
- Mowing should always be done with the engine at full throttle.

- For best results it is recommended that the first two laps be cut with the discharge thrown towards the center. After the first two laps, reverse the direction to throw the discharge to the outside for the balance of cutting. This will give a better appearance to the lawn.
- Under heavy conditions it may be necessary to go over the cut area a second time to get a clean cut.
- Do NOT attempt to mow heavy brush and weeds or extremely tall grass. Your tractor is designed to mow lawns, NOT clear brush.
- Keep the blades sharp and replace the blades when worn. Refer to **Cutting Blades** on page 25 of this manual for proper blade sharpening instructions.

Mulching

Cub Cadet Series 1000 tractors are equipped with a mulch kit which incorporates special blades, already standard on your tractor, in a process of recirculating grass clippings repeatedly beneath the cutting deck. The ultra-fine clippings are then forced back into the lawn where they act as a natural fertilizer. Observe the following points for the best results when mulching.

- Never attempt to mulch if the lawn is damp. Wet grass tends to stick to the underside of the cutting deck preventing proper mulching of the clippings.
- Do NOT attempt to mulch more than 1/3 the total height of the grass or approximately 1-1/2 inches. Doing so will cause the clippings to clump up beneath the deck and not be mulched effectively.
- Maintain a slow ground speed to allow the grass clippings more time to effectively be mulched.
- Always keep the throttle control lever in the FAST (rabbit) position while mowing. Failing to keep the engine at full throttle places strain on the tractor's engine and does not allow the blades to properly mulch grass.

NOTE: *It is not necessary to remove the discharge chute to operate the mower with the mulch kit installed.*



WARNING: Never install or remove the mulch plug while the engine is running.

42- and 46-inch Decks

On model LT1042, LT1045 and LT1046 the mulch kit is installed at the factory. To operate the cutting deck without mulching, simply remove the mulch plug by unthreading the plastic wing nut which fastens it to the cutting deck. This will allow the clippings to discharge out the side. See Figure 8.

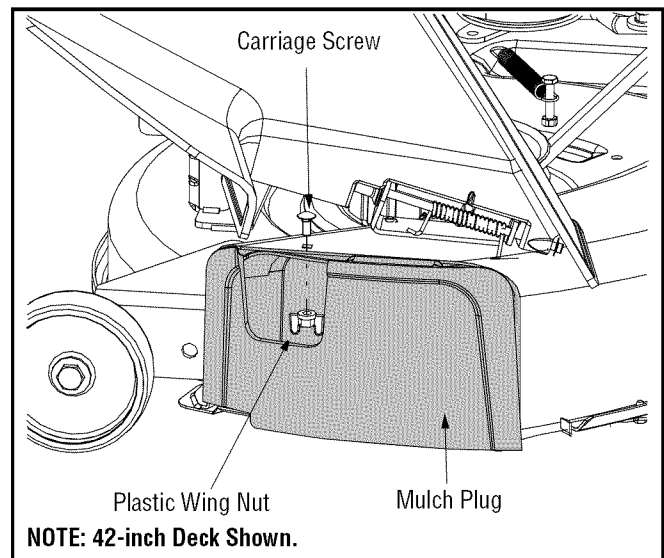

Figure 8

50-inch Decks

On model LT1050, the mulch kit is installed at the factory. To operate the cutting deck without mulching, simply remove the mulch plug by pivoting the discharge chute up and pulling the plug outward. To reinstall plug:

Locate two rectangular holes on the cutting deck surface.

- Pivot the discharge chute up to access the deck opening. See Figure 9.
- Insert the mulch plug, aligning the top edge of the plug with the deck as shown in the Figure 9. Make sure the notches on the plug are in the slots on the deck opening.
- Lightly tap on the plug with your hand to assure that the notches fit snugly under the chute tabs.

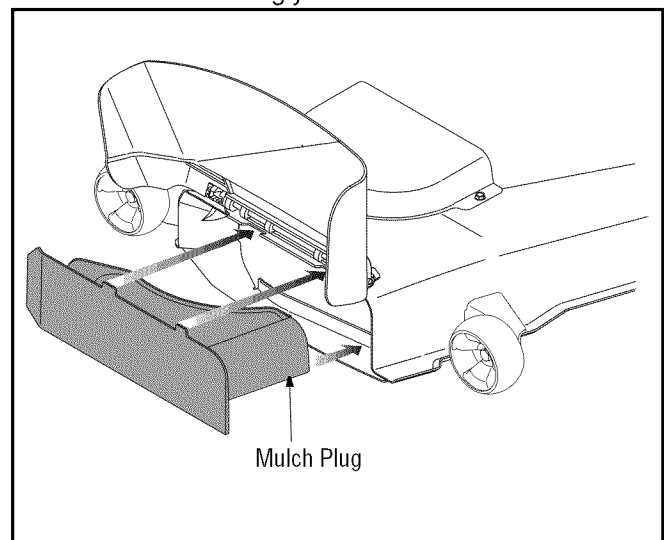

Figure 9

SECTION 6: MAKING ADJUSTMENTS



WARNING: Shut the engine off, remove the ignition key and engage the parking brake before making adjustments. Protect your hands by using heavy gloves when handling the blades.

Leveling the Deck

NOTE: Check the tractor's tire pressure before performing any deck leveling adjustments. Refer to **Tires** on page 25 for information regarding tire pressure.

Front To Rear

The front of the cutting deck is supported by a stabilizer bar that can be adjusted to level the deck from front to rear. The front of the deck should be between 1/4-inch and 3/8-inch lower than the rear of the deck. Adjust if necessary as follows:

- Park the tractor on a firm, level surface and place the deck lift lever in the top notch.
- Rotate the blade nearest the discharge chute so that it is parallel with the tractor.
- Measure the distance from the front of the blade tip to the ground and the rear of the blade tip to the ground.
- The first measurement taken should be between 1/4" and 3/8" less than the second measurement.
- Determine the approximate distance necessary for proper adjustment and proceed, if necessary.
- From the front of the tractor, loosen the hex lock nut on each end of the deck hanger rod, and turn away from the inner hex nuts. See Figure 10

NOTE: Some models have an extruded hanger bracket with a pivot cup, and only one hex nut and lock nut. Adjust using the same procedure.

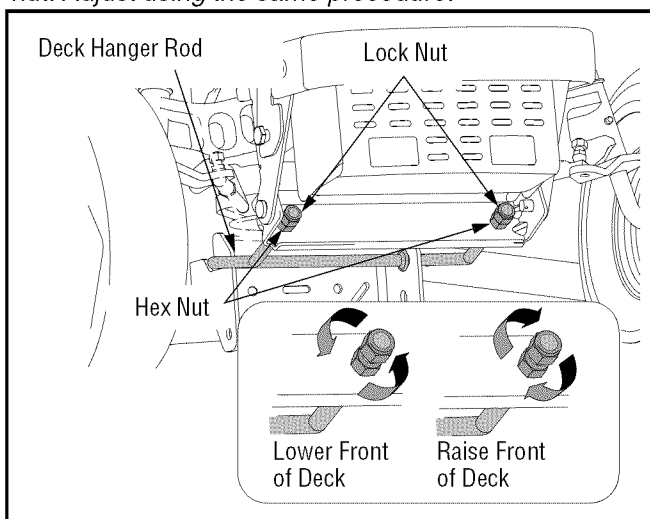

Figure 10

- Tighten the inner hex nuts front against the front hanger bracket to raise the front of the deck; loosen the hex nuts to lower the front of the deck. See Figure 10.
- Retighten the two lock nuts against the inner hex nuts when proper adjustment is achieved.

Side to Side

If the cutting deck appears to be mowing unevenly, a side to side adjustment can be performed. Adjust if necessary as follows:

- With the tractor parked on a firm, level surface, place the deck lift lever in the top notch (highest position) and rotate both blades so that they are perpendicular with the tractor.
- Measure the distance from the outside of the left blade tip to the ground and the distance from the outside of the right blade tip to the ground. Both measurements taken should be equal. If they're not, proceed to the next step.
- Loosen, but do NOT remove, the hex bolt on the left deck hanger bracket. See Figure 11.

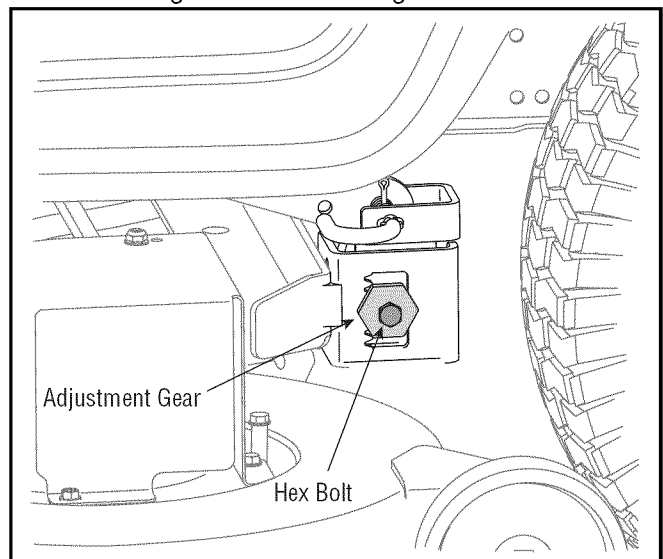

Figure 11

- Raise and lower the left side of the deck by using a wrench to turn the adjustment gear. See Figure 11.
- The deck is properly leveled when both blade tip measurements taken earlier are equal.
- Retighten the hex bolt on the left deck hanger bracket when proper adjustment is achieved.

Parking Brake Adjustment

If the tractor does not come to a complete stop when the brake pedal is completely depressed, or if the tractor's rear wheels can roll with the parking brake applied (and the hydrostatic relief valve open), the brake is in need of adjustment. See your *Cub Cadet* dealer to have the brake properly adjusted.

Seat Adjustment



WARNING: Before operating the tractor, make sure the seat is engaged in the seat stop, stand behind the machine and pull back on seat until fully engaged into stop.

To adjust the position of the seat forward or backward, move the seat adjustment lever to the left and slide the seat forward or rearward. Make sure seat is locked into position before operating the tractor.

Steering Adjustment

If the tractor turns tighter in one direction than the other, or if the ball joints are being replaced due to damage or wear, the steering drag links may need to be adjusted.

Adjust the drag links so that equal lengths are threaded into the ball joint on the left side and the ball joint on the right side:

- Loosen the jam nut found on the drag link at the rear of the ball joint. See Figure 12.
- Remove the hex nut on the top of ball joint.
- Thread the ball joint toward the jam nut to shorten the drag link. Thread the ball joint away from the jam nut to lengthen the drag link.
- Replace the hex nut and retighten the jam nut after proper adjustment is achieved.

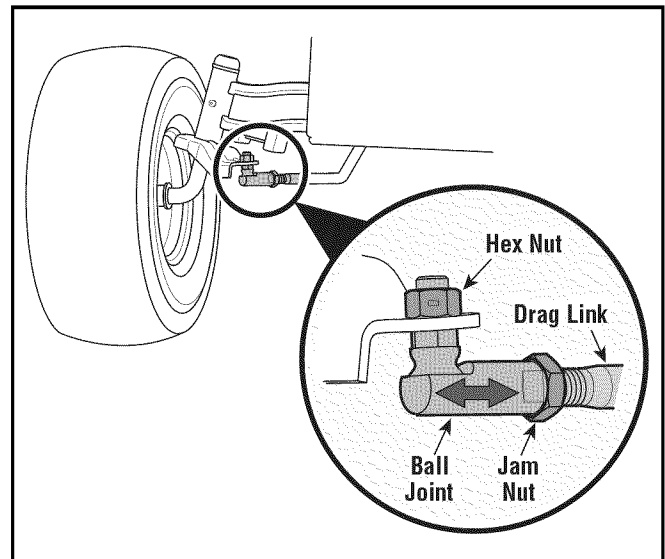

Figure 12

NOTE: Threading the ball joints too far onto the drag links will cause the front tires to "toe-in" too far. Proper toe-in is between 1/16" and 5/16".

Front tire toe-in can be measured as follows:

- Place the steering wheel in position for straight ahead travel.
- In front of the axle, measure the distance horizontally from the inside of the left rim to the inside of the right rim. Note the distance.
- Behind the axle, measure the distance horizontally from the inside of the left rim to the inside of the right rim. Note the distance.
- The measurement taken in front of the axle should be between 1/16" and 5/16" less than the measurement taken behind the axle.
- Adjust if necessary.

SECTION 7: MAINTAINING YOUR LAWN TRACTOR

NOTE: Refer to Maintenance Chart on page 30 for a reference of recommended maintenance intervals.



WARNING: Before performing any maintenance or repairs, disengage PTO, set parking brake, stop engine and remove key to prevent unintended starting.

Engine

Maintenance, repair, or replacement of the emission control devices and systems, which are being done at the customer's expense, may be performed by any engine repair establishment or individual. **Warranty repairs must be performed by a Cub Cadet Dealer.**

Engine Oil Recommendations

Using the proper type and weight of engine oil is extremely important, as is checking and changing oil regularly. Failure to use the correct oil, or operating the engine with dirty oil will result in premature engine wear and failure.

Engine Oil Type

Use only a high quality detergent oil of **API** (American Petroleum Institute) service class SG, SH, SJ or higher. Selection of engine oil should be based on the lowest anticipated temperatures prior to the next scheduled oil change. Refer to the Temperature / Oil Viscosity Chart.

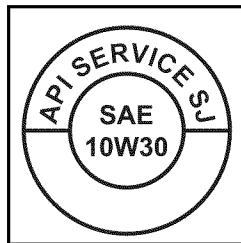

Checking the Oil Level

It is important to check the oil level at least every four hours of operation. Regular checking during the first 24 hours of operation is especially important. Check the oil level **before each use** as follows:

- Allow the engine a few minutes to rest after operation. This will give the oil time to drain into the crankcase sump and result in a more accurate dipstick reading.
- Clean the area around the oil fill cap/dipstick to prevent debris from entering the crankcase.
- Remove the oil fill cap/dipstick by lifting it (single cylinder models) or twisting it (twin cylinder models) out of the oil fill tube.
- Wipe the dipstick clean before pushing it all the way back into the oil fill tube. Withdraw the dipstick to check the oil level. Refer to figure at right.
- Always keep the oil level at or near the FULL mark on the dipstick. If the oil is low, add oil of the proper type up to the FULL mark. Always re-check the oil level with the dipstick before adding more oil.

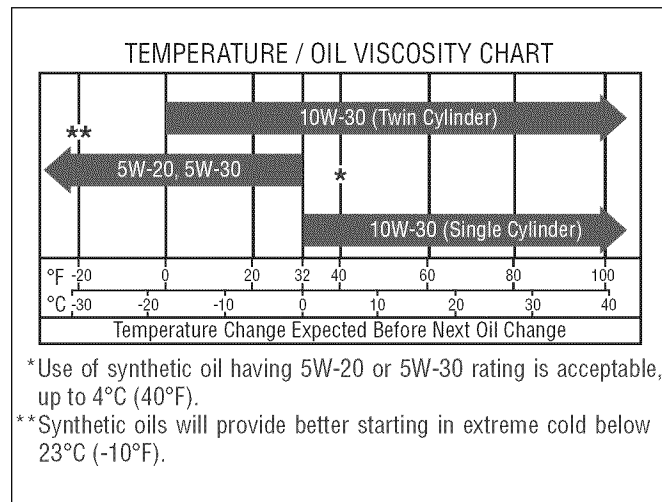

IMPORTANT: Never operate the engine with the oil level outside of the Operating Range on the dipstick.

- After checking the oil level (and adding oil, if necessary), reinstall the oil fill cap/dipstick onto the oil fill tube.

Adding Oil

If, after checking the oil level, you find the dipstick reads **L**, proceed as follows.

- Place the tractor on a level surface. Engage the parking brake, stop the engine and remove the key.
- Clean the area around the oil fill cap and fill tube to prevent debris from entering the crankcase.
- Remove the oil fill cap/dipstick from the oil fill tube and SLOWLY pour oil into the oil fill tube. Do NOT pour more than 6 oz. of oil at a time without first stopping and re-checking the oil level.
- Fill the crankcase until the oil level reaches the full (**F**) mark on the dipstick. See Figure above. Refer to the viscosity oil chart for information regarding the proper type of oil to add to the crankcase.

IMPORTANT: The engine may overheat and/or damage may result if the oil level is below the **L** or above the **F** on the dipstick.

- Reinstall the oil fill cap/dipstick securely onto the oil fill tube.

IMPORTANT: The oil fill cap/dipstick **must be installed securely onto the tube at all times when the engine is operating.** Severe engine damage could result from failure to do so.

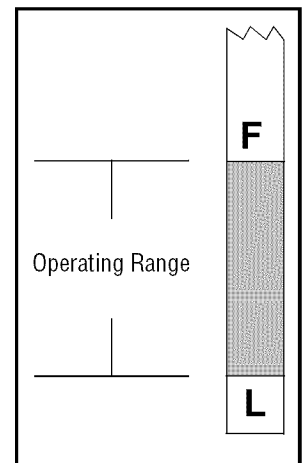

Changing the Engine Oil

The engine oil and oil filter should be changed after every 50 hours of tractor operation.



WARNING: If the engine has been recently run, the engine, muffler and surrounding metal surfaces will be hot and can cause burns to the skin. Allow the tractor to cool and use caution when removing

IMPORTANT: The oil filter should be changed at every oil change interval.

To complete an oil change, proceed as follows:

Draining the Oil

Run the engine for a few minutes to allow the oil in the crankcase to warm up. Warm oil will flow more freely and carry away more of the engine sediment which may have settled at the bottom of the crankcase. Use care to avoid burns from hot oil.

- Pop open the protective cap on the end of the oil drain valve to expose the drain port. See Figure 13.
- Remove the oil fill cap/ dipstick from the oil fill tube.
- Push the oil drain hose (packed with this manual) onto the oil drain port. Route the opposite end of the hose into an appropriate oil collection container with at least a 2.5 quart capacity, to collect the used oil.
- Push the oil drain valve in slightly, then rotate counterclockwise and pull outward to begin draining oil.

NOTE: The oil drain valve is found on the left-hand side of single cylinder engines and the right-hand side of twin-cylinder engines.

- After the oil has finished draining, push the oil drain valve back in, rotate it clockwise to lock the valve closed and re-cap the end of the oil drain valve to keep debris from entering the drain port.

IMPORTANT: Always change the oil filter when performing an oil change on your tractor's engine.

Changing the Oil Filter

After draining the oil, proceed as follows:

NOTE: Refer to the **Replacement Parts** table found on page 33 of this manual for the proper oil filter.

- Before removing the old oil filter, clean around its base to prevent debris from entering the crankcase.
- Grasp the oil filter and remove it from the filter adapter by turning it counterclockwise.
- Put a drop of oil on your fingertip and apply a light coating to the gasket of the new oil filter.

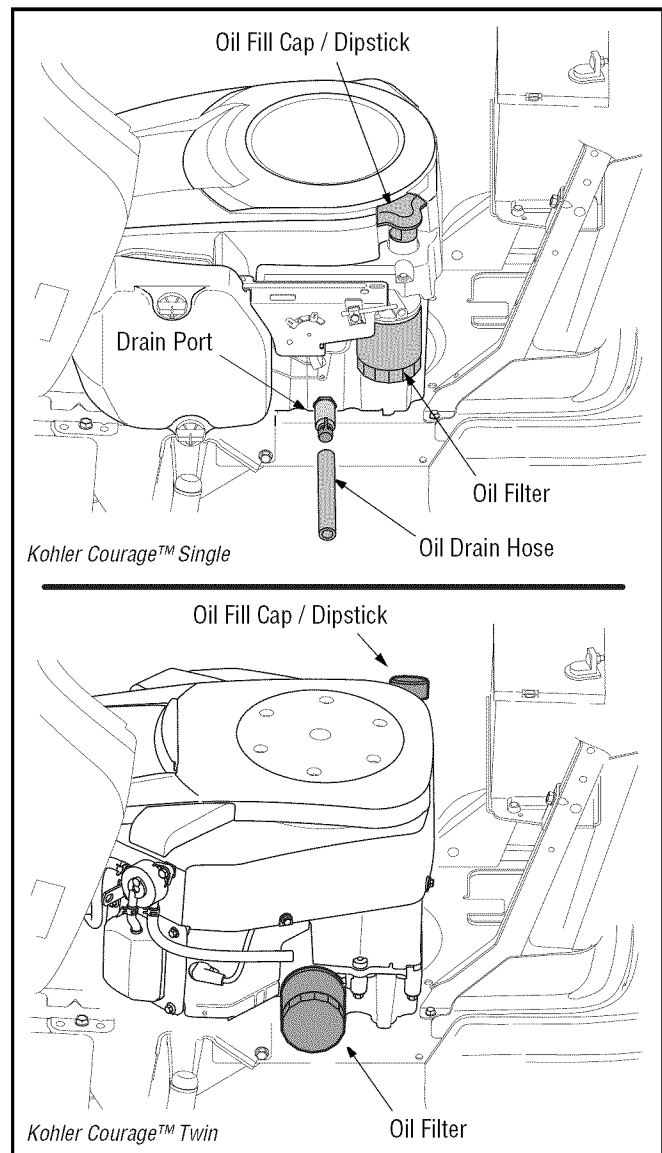

Figure 13

- Install the replacement oil filter on the engine by turning it clockwise onto the filter adapter until the rubber gasket makes contact with the base. Tighten the filter an additional **1/2 turn** after the gasket first makes contact.

Re-filling the Crankcase with Oil

IMPORTANT: On models LT1042 & LT 1045, the engine (with oil filter) has a capacity of 50.75 oz. (1.5 liters.). On models LT1046 & LT 1050, the engine (with oil filter) has a capacity of 57.5 oz. (1.7 liters). Do NOT overfill. Always check the level on the dipstick as instructed on page 19 before adding more oil.

NOTE: For the proper oil type, refer to the *Oil Temperature/Viscosity chart* on page 19 of this manual.

- Clean the area around the oil fill tube to prevent debris from entering the crankcase.

- **Slowly** pour oil into the fill tube. Fill the crankcase until the oil level reaches the full (F) mark on the dipstick (Refer to Page 19).
- Reinstall the oil fill cap/dipstick securely into the oil fill tube.

IMPORTANT: The oil fill cap/dipstick **must be installed securely onto the tube at all times when the engine is operating.** Severe engine damage could result from a failure to do so.

- Start the tractor engine and allow it to run for thirty seconds, then stop the engine and remove the ignition key.
- Check the oil level and add oil if necessary. **Do not overfill the engine crankcase.**
- Examine the area around the base of the oil fill tube, the oil filter adapter, and the oil drain valve for leaks before operating the tractor.

IMPORTANT: If leaks are present, have your engine serviced by your *Cub Cadet* dealer before operating the tractor.

Air Filter

The engine is equipped with a replaceable, high density paper air cleaner element and an oiled, foam precleaner. Always examine the air cleaner **before starting the engine.** Check for a buildup of dirt and debris around the air cleaner system. Keep this area clean. Also check for loose or damaged components. Replace all bent or damaged air cleaner components.

NOTE: *Starting the tractor with loose or damaged air cleaner components could allow unfiltered air into the engine causing premature wear and failure.*

Precleaner (Single Cylinder Engine)

Wash and re-oil the foam precleaner every **25 hours** of operation if equipped, (more often under extremely dusty or dirty conditions).

- Loosen the air cleaner cover knobs and remove the cover.
- Remove the precleaner from the upper section of the air cleaner cover.
- Wash the precleaner in warm water with detergent. Rinse the precleaner thoroughly until all traces of detergent are eliminated. Squeeze out excess water (do not wring). Allow the precleaner to air dry.
- Saturate the precleaner with new engine oil. Squeeze out all excess oil.
- Reinstall the precleaner into the upper section of the air cleaner cover.

- Reinstall the cover and tighten the knobs securely.

Paper Element (Single Cylinder Engine)

The paper element should be replaced at least once a season, or every **100 hours** of operation. Replace more frequently if the tractor is operated under extremely dusty conditions. To replace the paper element, proceed as follows:

- Loosen the air cleaner cover knobs and remove the cover.
- Carefully remove the air cleaner element.

IMPORTANT: Do **not** wash the paper element or use pressurized air, as this will damage the element.

Examine the element and discard if dirt and/or damage is present.

NOTE: *Handle new elements carefully; do not use if the sealing surfaces are bent or damaged.*

- If any loose dirt or debris fell on the air cleaner base when the element was removed, carefully remove it and wipe the base clean. Be careful that none of it drops into the intake.
- Check the air cleaner base. Make sure it is not damaged. Also check the air cleaner cover for damage or improper fit. Replace all damaged air cleaner components.
- Clean all air cleaner components of any accumulated dirt or foreign material. Prevent any dirt from entering the throat of carburetor.
- Install the replacement air cleaner element with the pleated side *out* and seat the rubber seal onto the edges of the air cleaner base. See Figure 11
- Reinstall the cover and tighten the knobs securely.

Precleaner (Twin Cylinder Engine)

Wash and re-oil the foam precleaner every **25 hours** of operation if equipped, (more often under extremely dusty or dirty conditions).

- Pivot the air cleaner cover upward and unhook the wire latch which secures the element in place.
- Carefully remove the precleaner from around the air cleaner element.
- Wash the precleaner in warm water with detergent. Rinse the precleaner thoroughly until all traces of detergent are eliminated. Squeeze out excess water (do not wring). Allow the precleaner to air dry.
- Saturate the precleaner with new engine oil. Squeeze out all excess oil.
- Reinstall the precleaner over the paper element.
- Lower the wire latch to secure the element in place and pivot the air cleaner cover downward.

Paper Element (Twin Cylinder Engine)

The paper element should be replaced at least once a season, or every **100 hours** of operation. Replace more frequently if the tractor is operated under extremely dusty conditions. To replace the paper element, proceed as follows:

- Pivot the air cleaner cover upward and unhook the wire latch which secures the element in place.
- Remove the air cleaner element with precleaner.
- Carefully remove the precleaner from the element and service as instructed earlier in this section.

IMPORTANT: Do **not** wash the paper element or use pressurized air, as this will damage the element.

Examine the element and discard if dirt and/or damage is present.

NOTE: Handle new elements carefully; do not use if the sealing surfaces are bent or damaged.

- If any loose dirt or debris fell on the air cleaner base when the element was removed, carefully remove it and wipe the base clean. Be careful that none of it drops into the intake.
- Check the air cleaner base. Make sure it is secured and not damaged. Also check the air cleaner cover for damage or improper fit. Replace all damaged air cleaner components.
- Install the precleaner over the new paper element and reinstall the element.
- Lower the wire latch to secure the element in place and pivot the air cleaner cover downward.

Spark Plug(s)

Once a season, or every **100 hours** of operation, remove the spark plug(s), check condition, and reset the gap or replace with a new plug(s) as necessary.

- Lift the tractor's hood and locate the spark plug wire on the front, right area of the engine.
- Carefully pull the spark plug wire boot(s) off of the spark plug(s).
- Before removing each spark plug, clean the area around the base of the plug to keep dirt and debris out of the engine.
- Using a ratchet with a 5/8-inch spark plug socket, remove the spark plug and check its condition.
- Replace the plug if worn, dirty or damaged. Reuse only after resetting the gap as instructed.

NOTE: Do not clean the spark plug with an abrasive grit. Some grit could remain in the spark plug and enter the engine causing extensive wear and damage.

- Check the gap using a feeler gauge and adjust, if necessary, by carefully bending the ground electrode. See Figure 14. Set the spark plug gap to 0.030 in. (.76 mm).

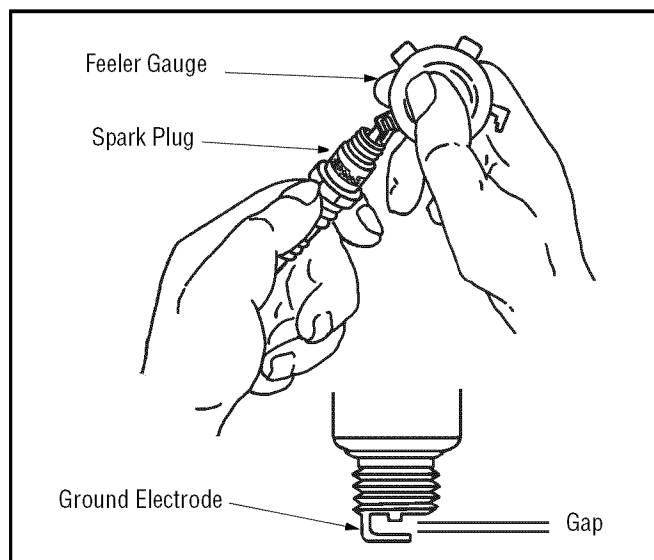

- Reinstall the spark plug into the cylinder head. Torque the spark plug to **28/32 ft. lb. (38.0/43.4 N·m)**.
- Place the spark plug wire boot over the spark plug and press until you feel it “click” in place.

Figure 14

Fuel Filter



WARNING: Do not replace the fuel filter when engine is hot.

The engine is equipped with an inline fuel filter located on the left side of the engine.

Visually inspect the filter periodically for a build-up of residue inside the filter body, and for a dirty element which can be indicated by discoloration. Replace the fuel filter when dirty.

Cleaning the Engine And Deck

Any fuel or oil spilled on the machine should be wiped off promptly.

Do NOT allow debris to accumulate around the cooling fins of the engine or on any other part of the machine, especially the belts and pulleys.

Smart Jet™

Your tractor's deck is equipped with a water port on its surface as part of its deck wash system.

Use the Smart Jet™ to rinse grass clippings from the deck's underside and prevent the buildup of corrosive chemicals. Complete the following steps **AFTER EACH MOWING**:

1. Drive the tractor to a level, clear spot on your lawn, near enough for your garden hose to reach.

IMPORTANT: Make certain the tractor's discharge chute is directed **AWAY** from your house, garage, parked cars, etc.

2. Disengage the PTO (Blade Engage), set the parking brake and stop the engine.
3. Thread the hose coupler (packaged with your tractor's Operator's Manual) onto the end of your garden hose.
4. Attach the hose coupler to the water port on your deck's surface. See Figure 15.

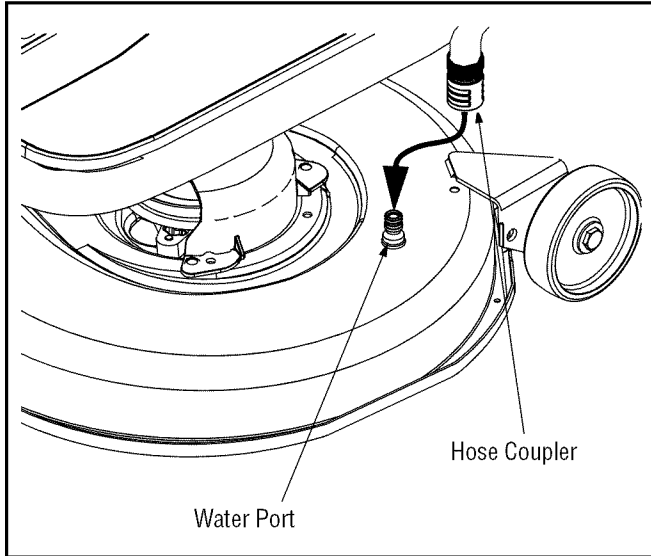

Figure 15

5. Turn the water on.
6. While sitting in the operator's position on the tractor, start the engine and place the throttle lever in the FAST (rabbit) position.
7. Move the tractor's PTO (Blade Engage) into the ON position.
8. **Remain in the operator's position** with the cutting deck engaged for a minimum of two minutes, allowing the underside of the cutting deck to thoroughly rinse.
9. Move the tractor's PTO (Blade Engage) into the OFF position.
10. Turn the ignition key to the STOP position to turn the tractor's engine off.
11. Turn the water off and detach the hose coupler from the water port on your deck's surface.
12. Repeat step 4- step 11 on the opposite side of the cutting deck (Models LT 1045, LT 1046 and LT 1050).

Lubrication



WARNING: Before lubricating, repairing, or inspecting, always disengage PTO, set parking brake, stop engine and remove key to prevent unintended starting.

Engine

Refer to **Engine** on page 19 for instruction regarding all engine-related lubrication.

Front Wheels

Each of the front wheel axles and rims is equipped with a grease fitting. See Figure 16. Lubricate with a No. 2 multi-purpose grease applied with a grease gun after every 25 hours of tractor operation.

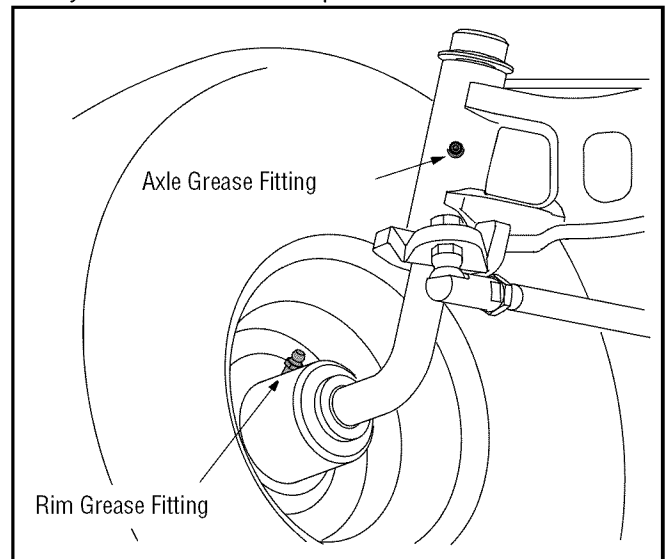

Figure 16

Pivot Points & Linkage

Lubricate all the pivot points on the drive system, parking brake and lift linkage at least once a season with light oil.

Deck Wheels

Each of the tractor deck's front gauge wheels is equipped with a grease fitting. Lubricate with a No. 2 multi-purpose grease applied with a grease gun after every 25 hours of tractor operation.

Deck Spindle

Grease fittings can be found on the front of each deck spindle. Lubricate with 251H EP grease or an equivalent No. 2 multi-purpose lithium grease. Using a grease gun, apply two strokes (minimum) or sufficient grease to the spindle shaft.

Deck Idler (Model LT1050 only)

A grease fitting can be found on the pivoting idler bracket on the rear of 50-inch decks. Lubricate with a No. 2 multi-purpose grease applied with a grease gun after every 25 hours of tractor operation.

Carburetor

NOTE: Carburetor adjustments should be made only after the engine has warmed up.

The engines on *Cub Cadet* Series 1000 tractors are equipped with a fixed main jet carburetor.

Carburetors are equipped with a idle speed adjustment screw and a low idle fuel mixture screw.

The carburetor is designed to deliver the correct fuel-to-air mixture to the engine under all operating conditions. The main fuel jet is calibrated at the factory and is not adjustable. The low idle fuel mixture screw is also set at the factory and normally does not need adjustment.

If the engine is hard to start, runs roughly, or stalls at low idle speed, it may be necessary to adjust or service the carburetor.

Turning the low idle mixture screw in (clockwise) decreases the supply of fuel to the carburetor. This gives a leaner fuel-to-air mixture. Turning the mixture screw out (counterclockwise) increases the supply of fuel to the carburetor. This gives a richer fuel-to-air mixture. Setting the screw midway between the lean and rich position will usually give the best results.

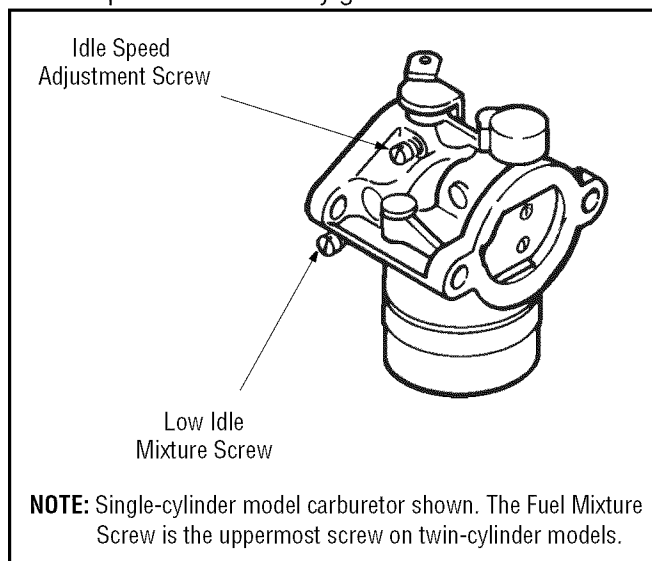

Figure 17

Troubleshooting

If engine troubles are experienced that appear to be fuel system related, check the following areas before adjusting the carburetor.

- Make sure the fuel tank is filled with clean, fresh gasoline.
- Make sure the fuel tank cap vent is not blocked and that it is operating properly.
- If the fuel tank is equipped with a shut-off valve, make sure it is open.
- Make sure that the in-line fuel filter is clean and unobstructed. Replace the filter if necessary.

- Make sure fuel is reaching the carburetor. Check the fuel lines and fuel pump for restrictions or faulty components, replace as necessary.
- Make sure the air cleaner element is clean and all air cleaner element components are secure.

If, after checking the items listed above, the engine is hard to start, runs roughly, or stalls at low idle speed, it may be necessary to adjust or service the carburetor.

Adjustment

NOTE: Engines may have a fixed idle or limiter cap on the idle fuel adjusting screw. Step 2 can only be performed within the limits allowed by the cap.

1. Start the engine and run at half throttle for five to 10 minutes to warm up. The engine must be warm before performing steps 2 and 3.
2. **Low Idle Fuel Screw Setting:** Place the throttle into the “idle” or “slow” position. Turn the low idle fuel mixture screw out (counterclockwise) from the preliminary setting until engine speed decreases (rich). Note the position of the screw. Now turn the mixture screw in (clockwise). The engine speed may increase, then it will decrease as the screw is turned in (lean). Note the position of the screw. Set the adjusting screw midway between the rich and lean settings. See Figure 18.

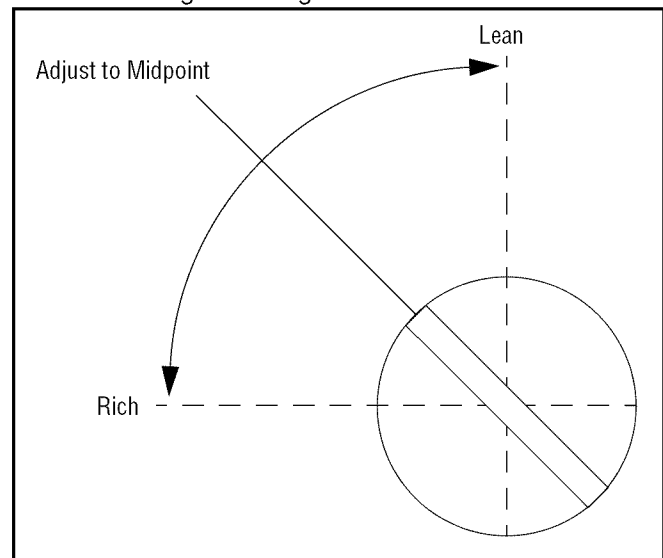

Figure 18

3. **Low Idle Speed Setting:** Place the throttle control into the “idle” or “slow” position. Set the low idle speed to **2150 RPM*** (± 75 RPM) on Models LT1042 & LT1045 (**1500 RPM*** (± 75 RPM) on Models LT1046 & LT1050) by turning the low idle speed adjusting screw **in or out**. Check the speed using a tachometer.

NOTE: To ensure best results when setting the low idle fuel Screw, the low idle speed must not exceed 2150 RPM (± 75 RPM) on single cylinder engines and 1200 RPM* (± 75 RPM) on twin cylinder engines.

SECTION 8: SERVICE

Tires



WARNING: Never exceed the maximum inflation pressure shown on the sidewall of the tire.

The recommended operating tire pressure is approximately 10 psi for the rear tires and 14 psi for the front tires.

Refer to the tire sidewall for exact tire manufacturer's recommended or maximum psi. Do not overinflate. Uneven tire pressure could cause the cutting deck to mow unevenly.

Fuse

A fuse is installed in your tractor's wiring harness to protect the tractor's electrical system from damage caused by excessive amperage.

If the electrical system does not function, or your tractor's engine will not crank, first check to be certain that the fuse has not blown.

It is located under the hood, mounted behind the top of the dash panel on the support bar.

IMPORTANT: Always use a fuse with the same amperage capacity for replacement.



WARNING: Before servicing, repairing, or inspecting, always disengage PTO, set parking brake, stop engine and remove key to prevent unintended starting.

Cutting Blades



WARNING: Shut the engine off, remove ignition key and disconnect the spark plug wire(s) before removing the cutting blade(s) for sharpening or replacement. Protect your hands by using heavy gloves when grasping the blade.



WARNING: Periodically inspect the blade adapter and/or spindle for cracks or damage, especially if you strike a foreign object. Replace immediately if damaged.

The blades may be removed as follows.

- Remove the deck from beneath the tractor, (refer to **Cutting Deck Removal** on page 26) then gently flip the deck over to expose its underside.
- Place a block of wood between the center deck housing baffle and the cutting blade to act as a stabilizer. See Figure 19.

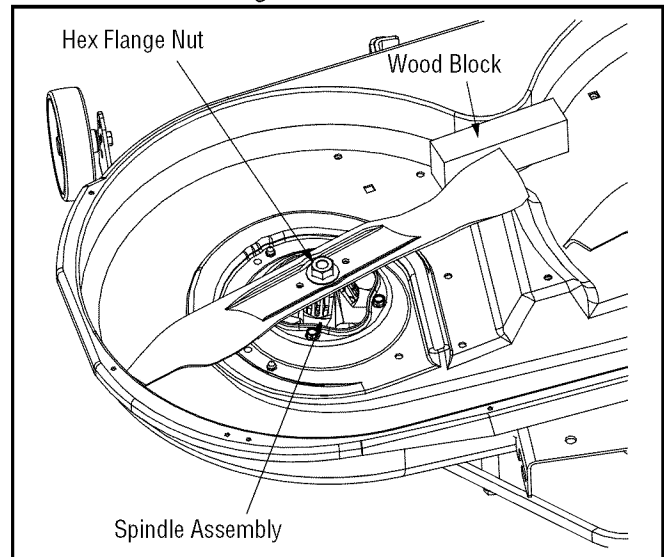

Figure 19

- Remove the hex flange nut that secures the blade to the spindle assembly. See Figure 19.

To properly sharpen the cutting blades, remove equal amounts of metal from both ends of the blades along the cutting edges, parallel to the trailing edge, at a 25° to 30° angle.

IMPORTANT: If the cutting edge of the blade has already been sharpened, or if any metal separation is present, replace the blades with new ones.

It is important that each cutting blade edge be ground equally to maintain proper blade balance. A poorly balanced blade will cause excessive vibration and may cause damage to the tractor and result in personal injury.

The blade can be tested by balancing it on a round shaft screwdriver. Grind metal from the heavy side until it balances evenly.

IMPORTANT: When replacing the blade, be sure to install the blade with the side of the blade marked "Bottom" (or with a part number stamped in it) facing the ground when the mower is in the operating position.

IMPORTANT: Use a torque wrench to tighten the blade spindle hex flange nut to between 70 lbs-ft and 90 lbs-ft.

Battery



California Proposition 65 Warning: Battery posts, terminals, and related accessories contain lead and lead compounds, chemicals known to the State of California to cause cancer and reproductive harm. Wash hands after handling.

The battery is sealed and is maintenance-free. Acid levels cannot be checked and fluid can not be added.

- Always keep the battery cables and terminals clean and free of corrosive build-up.
- After cleaning the battery and terminals, apply a light coat of petroleum jelly or grease to both terminals
- Always keep the rubber boot positioned over the positive terminal to prevent shorting.

IMPORTANT: If removing the battery, disconnect the NEGATIVE (Black) wire from its terminal first, followed by the POSITIVE (Red) wire. When re-installing the battery, always connect the POSITIVE (Red) wire its terminal first, followed by the NEGATIVE (Black) wire. Be certain that the wires are connected to the correct terminals; reversing them could change the polarity and cause damage to your engine's alternating system.

Jump Starting



WARNING: Never jump start a damaged or frozen battery. Be certain the vehicles do not touch, and ignitions are off. Do not allow cable clamps to touch.

- Connect positive (+) cable to positive post (+) of your tractor's discharged battery.
- Connect the other end of the cable to the (positive +) post of the jumper battery.
- Connect the second cable (negative -) to the other post of the jumper battery.
- Make the final connection on the engine block of the tractor, away from the battery. Attach to a unpainted part to assure a good connection.

IMPORTANT: If the jumper battery is installed on a vehicle (i.e. car, truck), do NOT start the vehicle's engine when jump starting your tractor.

- Start the tractor (as instructed on page 13).
- Set the tractor's parking brake before removing the jumper cables, in reverse order of connection.

Charging



WARNING: Batteries give off an explosive gas while charging. Charge the battery in a well ventilated area and keep away from an open flame or pilot light as on a water heater, space heater, furnace, clothes dryer or other gas appliances.

IMPORTANT: When charging your tractor's battery, use only a charger designed for 12V lead-acid batteries. Read your battery charger's Owner's Manual prior to charging your tractor's battery. Always follow its instructions and heed its warnings.

If your tractor has not been put into use for an extended period of time, charge the battery as follows:

1. Set your battery charger to deliver a maximum of 10 amperes.
2. If your battery charger is automatic, charge the battery until the charger indicates that charging is complete. If the charger is not automatic, charge for no fewer than eight hours.

Cutting Deck Removal

To remove the cutting deck, proceed as follows:

- Place the PTO/Blade Engage knob in the disengaged (OFF) position and engage the parking brake.
- Lower the deck by moving the deck lift lever into the bottom notch on the right fender.
- Remove the deck belt from around the tractor's electric PTO clutch (refer to **Changing the Deck Belt**).
- Looking at the cutting deck from the left side of the tractor, locate the deck support pin on the rear left side of the deck.
- Rotate the pin slightly toward the rear of the tractor and release it.
- Pull the deck support pin outward to release the deck from the deck lift arm. See Figure 20.

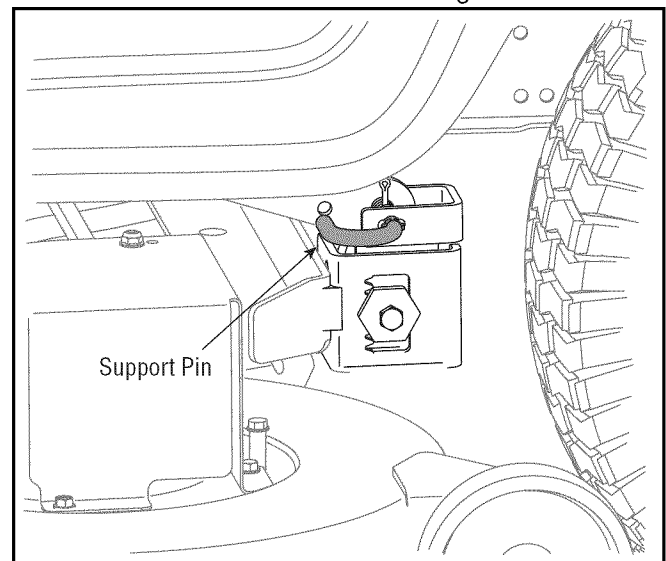

Figure 20

- Repeat the above steps on the tractor's right side.
- Move the deck lift lever into the top notch to raise the deck lift arms up and out of the way.
- Gently slide the cutting deck toward the front of the tractor allowing the hooks on the deck to release themselves from the deck stabilizer rod.
- Gently slide the cutting deck (from the right side) out from underneath the tractor.

Changing The Transmission Drive Belt

NOTE: Several components must be removed and special tools used in order to change the tractor's transmission drive belt. See your Cub Cadet dealer to have your drive belt replaced.

Hydrostatic Transmission

Keep the area around the transmission cooling fan free of grass and debris at all times. The hydrostatic transmission is sealed at the factory and is maintenance free. The fluid level cannot be checked and **on most models**, cannot be changed.

IMPORTANT: Several tractor components and parts (pedals, seat, fender, fuel tank, etc.) must be removed in order to refill the transmission after draining it.

If your tractor is equipped with a transmission drain plug (see Figure 21), exposed to extreme conditions (hilly terrain, towing, etc.) and you choose to change the hydrostatic fluid, do so after the tractor's initial 50 hours of operation and once a season thereafter.

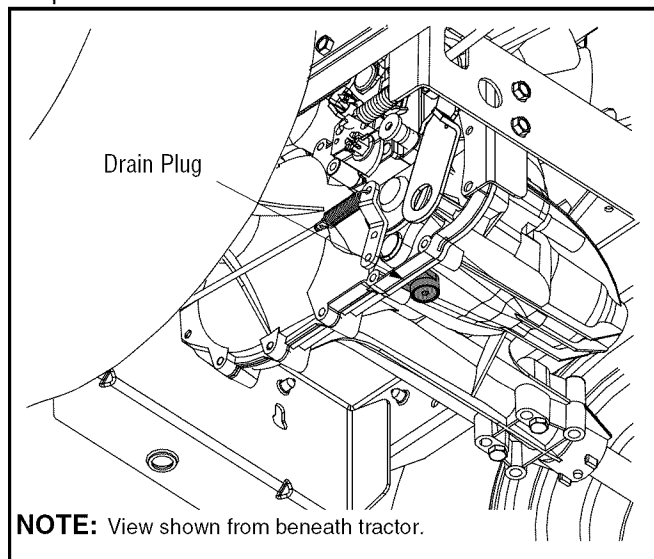

Figure 21

After draining the oil, refill the transmission with 76 oz. (to the top of the fill hole found on the transmission's surface) with any SAE 20W50 motor oil.

Changing the Deck Belt



WARNING: Be sure to shut the engine off and remove the ignition key, to prevent unintended starting.



WARNING: Avoid the possibility of a pinching injury. Do not place your fingers on the idler spring or between the belt and a pulley while removing the belt.

All belts on your tractor are subject to wear and should be replaced if any signs of wear are present.

IMPORTANT: The V-belts found on your tractor are specially designed to engage and disengage safely. A substitute (non-OEM) V-belt can be dangerous by not disengaging completely. For a proper working machine, use factory approved belts.

To change or replace the deck belt on your tractor, proceed as follows:

- Lower the deck by moving the deck lift lever into the bottom notch on the right fender.
- Remove the belt guards by removing the self-tapping screws that fasten them to the deck.

42-inch Decks

- Remove the belt keeper rod from around the electric PTO clutch.
- Remove the cutting deck as instructed earlier in this section.

46-inch Decks

- Carefully grasp the idler pulley and pivot it toward the tractor's left side to relieve tension on the belt. See Figure 22.

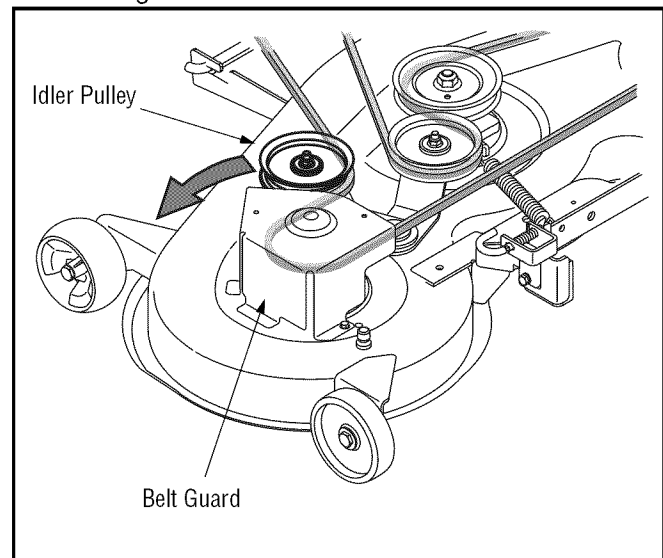

Figure 22

- With belt tension relieved, **carefully remove the belt from around the left-hand spindle pulley.**

50-inch Decks

- To ease in removing the belt in later steps, loosen, but do not remove, the bolt which secures the pivoting idler pulley to the idler bracket. See Figure 23.

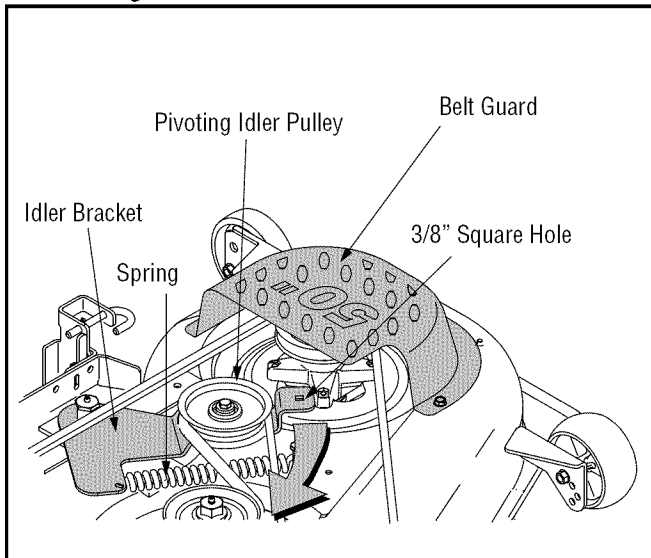

Figure 23

- Insert a 3/8"-drive ratchet wrench (set to *tighten*) into the square hole found in the idler bracket on the left side of the deck's surface. See Figure 23.
- Grasp the ratchet's handle and pivot it toward the tractor's right side to relieve tension on the belt.
- With belt tension relieved, **carefully remove the belt from around the left-hand spindle pulley.**

IMPORTANT: Carefully allow the ratchet to pivot rearward before removing it from the square hole.

All Models

- Remove the deck belt from around all pulleys, including the deck idler pulley(s) and the electric PTO clutch.

NOTE: *The idler pulley(s) may have to be loosened, but not removed, in order to remove the belt from around them.*

- Route the new belts (deck belt first) as shown on the following page.
- Retighten idler pulley(s), if loosened earlier.
- Remount the belt guards removed earlier.

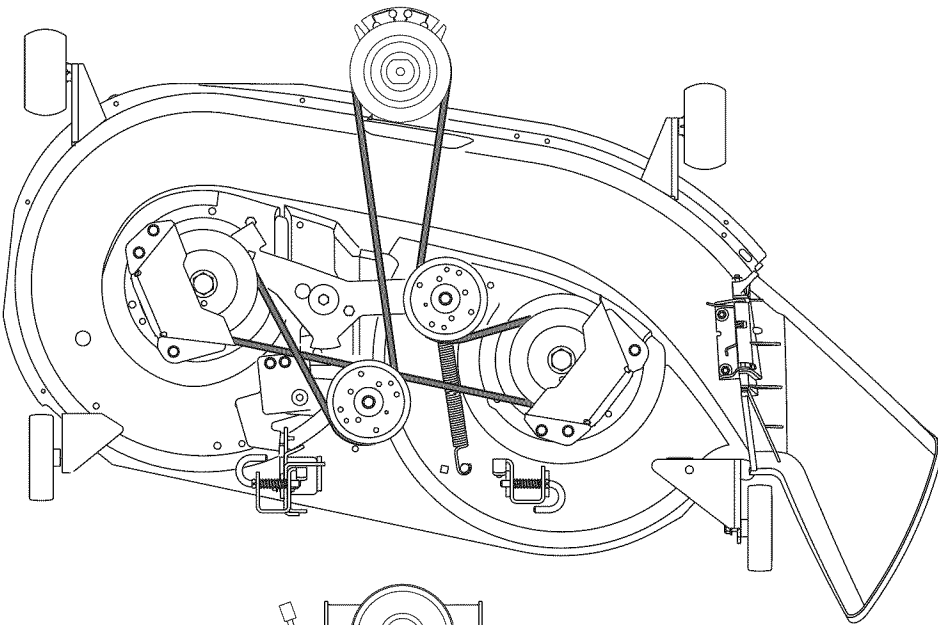

LT1042

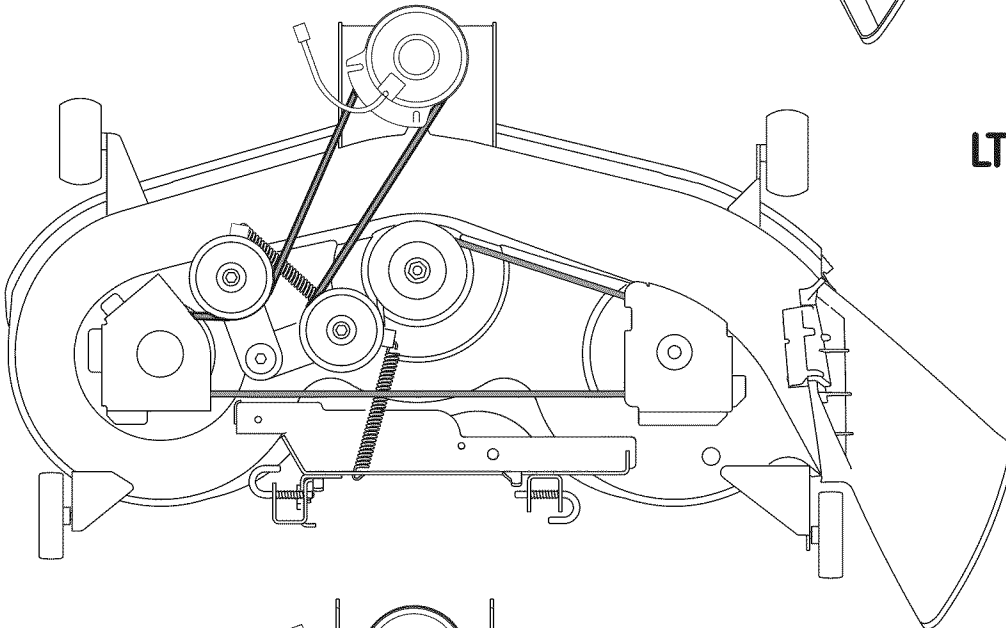

LT1045 & LT1046

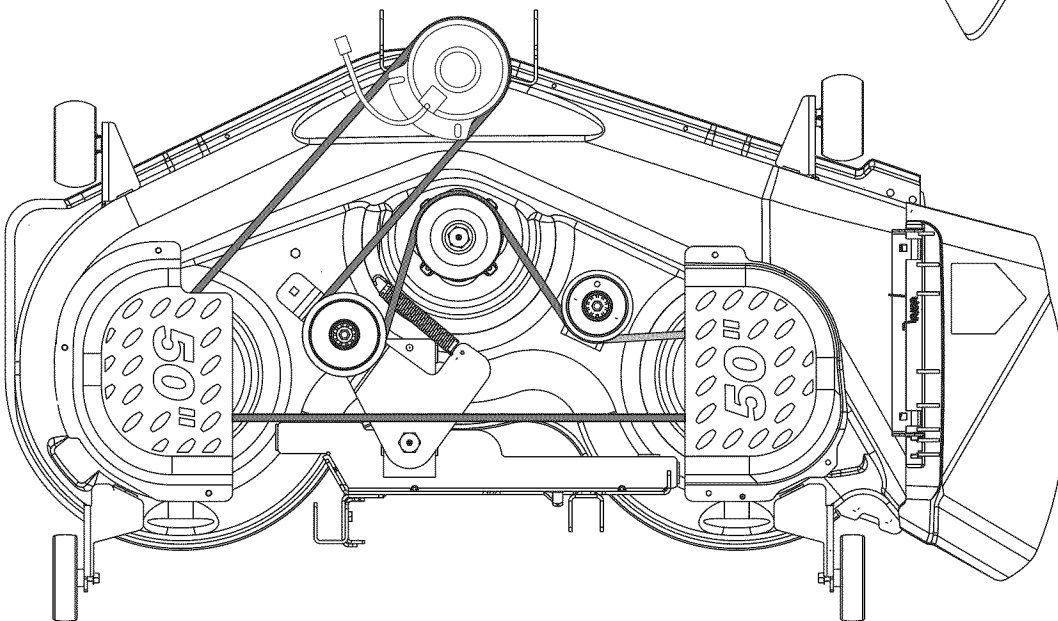

LT1050

SECTION 9: OFF-SEASON STORAGE

Clean and lubricate the tractor as instructed in **Section 7: MAINTAINING YOUR LAWN TRACTOR** on page 19 of this manual before storing for an extended period.

Engine

If the engine will be out of service for two months or more, use the following storage procedure:

- Clean the exterior surfaces of the engine.
- Change the oil and filter while the engine is still warm from operation. Refer to **Changing the Engine Oil** on page 20.
- The fuel system must be completely emptied, or the gasoline must be treated with a fuel stabilizer such as *STA-BIL*® to prevent deterioration. If you choose to use a stabilizer, follow the manufacturers recommendations, and add the correct amount for the capacity of the fuel system. Fill the fuel tank with clean, fresh gasoline. Run the engine for 2- to 3 minutes to get stabilized fuel into the carburetor.

To empty the system, run the engine until the tank and system are empty.



WARNING: Allow engine to cool. Extinguish cigarettes, cigars, pipes, and other sources of ignition prior to draining fuel. Drain fuel only into an approved container outdoors, away from an open flame.

- Remove the spark plug. Add one tablespoon of engine oil into the spark plug hole. Install the plug, but do not reconnect the plug wire. Crank the engine two or three revolutions.
- Store the engine in a clean, dry place.



WARNING: Never store the machine or fuel container indoors where there is an open flame, spark or pilot light such as on water heater, furnace, clothes dryer or other gas appliance.

SECTION 10: MAINTENANCE SCHEDULE

	Before Each Use	Every 10 Hours	Every 25 Hours	Every 50 Hours	Every 100 Hours	Prior to Storing
Clean Hood/Dash Louvers		✓				✓
Check Engine Oil Level	✓					
Check Air Filter for dirty, loose or damaged parts.	✓					
Clean and Re-oil Air Filter's Foam Precleaner			✓			
Replace Air Filter Element					✓	
Change Engine Oil and Replace Oil Filter				✓		
Clean Battery Terminals		✓				✓
Lube Front Axles and Rims			✓			✓
Clean Engine Cooling Fins			✓			✓
Lube Front Deck Wheels			✓			✓
Lube Deck Spindles			✓			✓
Lube Pedal Pivot Points		✓				✓
Check Spark Plug Condition & Gap					✓	✓
Replace Fuel Filter					✓	

SECTION 11: MAINTENANCE LOG

Please keep a record of the maintenance performed on your tractor.

Date	Hour Meter	Maintenance	Performed by

SECTION 12: TROUBLESHOOTING

Trouble	Possible Cause(s)	Corrective Action
Engine fails to start	PTO/Blade Engage knob engaged. Parking brake not engaged. Spark plug wire(s) disconnected. Throttle control lever not in correct starting position. Choke not activated Fuel tank empty, or stale fuel. Blocked fuel line. Faulty spark plug. Engine flooded.	Place knob in disengaged (OFF) position. Engage parking brake. Connect wire to spark plug. Place throttle lever to FAST position. Pull out the CHOKE control. Fill tank with clean, fresh (less than 30 days old) gas. Clean fuel line or replace fuel filter. Clean, adjust gap or replace plug. Crank engine with throttle in FAST position.
Engine runs erratic	Unit running with CHOKE activated. Spark plug wire(s) loose. Blocked fuel line or stale fuel. Vent in gas cap plugged. Water or dirt in fuel system. Dirty air cleaner.	Push CHOKE control in. Connect and tighten spark plug wire(s). Clean fuel line; fill tank with clean, fresh (less than 30 days old) gasoline. Replace fuel filter, if so equipped. Clear vent or replace cap if damaged. Drain fuel tank. Refill with clean, fresh (less than 30 days old) gasoline. Replace air cleaner paper element or clean foam pre-cleaner.
Engine overheats	Engine oil level low. Air flow restricted.	Fill crankcase with proper amount and weight of oil. Clean grass clippings and debris from around the engine's cooling fins and blower housing.
Engine hesitates at high RPM	Spark plug gap too close.	Remove spark plug and reset the gap.
Idles poorly	Spark plug fouled, faulty or gap too wide. Dirty air cleaner.	Replace spark plug. Set plug gap. Replace air cleaner element and/or clean pre-cleaner.
Excessive vibration	Cutting blade loose or unbalanced. Damaged or bent cutting blade.	Tighten blade and spindle. Balance blade. Replace blade.
Mower will not mulch grass	Engine speed too low. Wet grass. Excessively high grass. Dull blade.	Place throttle in FAST (rabbit) position. Do not mow when grass is wet; wait until later to cut. Mow once at a high cutting height, then mow again at desired height or make a narrower cutting swath. Sharpen or replace blade.
Uneven cut	Deck not leveled properly. Dull blade. Uneven tire pressure.	Perform side-to-side or side-to-side deck adjustment. Sharpen or replace blade. Check tire pressure in all four tires.

SECTION 13: ATTACHMENTS & ACCESSORIES

The following attachments and accessories are compatible for **Series 1000 Lawn Tractors**. See your *Cub Cadet* dealer or the retailer from which you purchased your tractor for information regarding price and availability.

NOTE: *Cub Cadet Series 1000 lawn tractors are NOT designed for use with any type of ground-engaging attachments (e.g. tiller or moldboard plow). Use of this type of equipment WILL void the tractor's warranty.*

Model Number	Attachment / Accessory
19A-102	16 cu. ft. Steel Tow Cart
19A-103	42" Tow-Behind Sweeper
19A-104	25 gal. Tow-Behind Sprayer
19A-105	Tow-Behind Broadcast Spreader
19A-106	10 cu. ft. Poly Tow Cart
19A-107	48" Tow-Behind Dethacher
19A-108	48" Tow-Behind Plug Aerator
19A-109	48" Tow-Behind Spike Aerator
19A-110	48" Tow-Behind Aerator Spreader
19A-112	Box Scraper
19A-113	48" Push Lawn Roller (Does <i>Not</i> Attach to Tractor)
190-217B	Mow-N-Vac Debris Collection System
190-425	17 cu. ft. Dump Cart
190-458	15 cu. ft. Dump Cart
190-653	10 cu. ft. Dump Cart
190-459	46-inch Lawn Sweeper
190-670	Twin Bagger Grass Collector (For 42-inch Decks)
190-678	Twin Bagger Grass Collector (For 46-inch Decks)
190-190	Triple Bagger Grass Collector (For 50-inch Decks)
190-671	Rear Tire Chain Set (20" x 9")
190-032	42-inch Two-stage Snow Thrower
190-672	Front Bumper Kit
190-674	46-inch Front Dozer Blade
190-675	Rear Wheel Weight Set

SECTION 14: REPLACEMENT PARTS

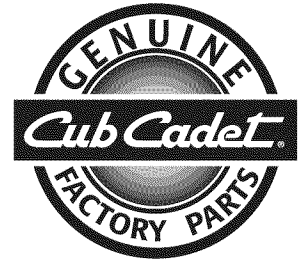
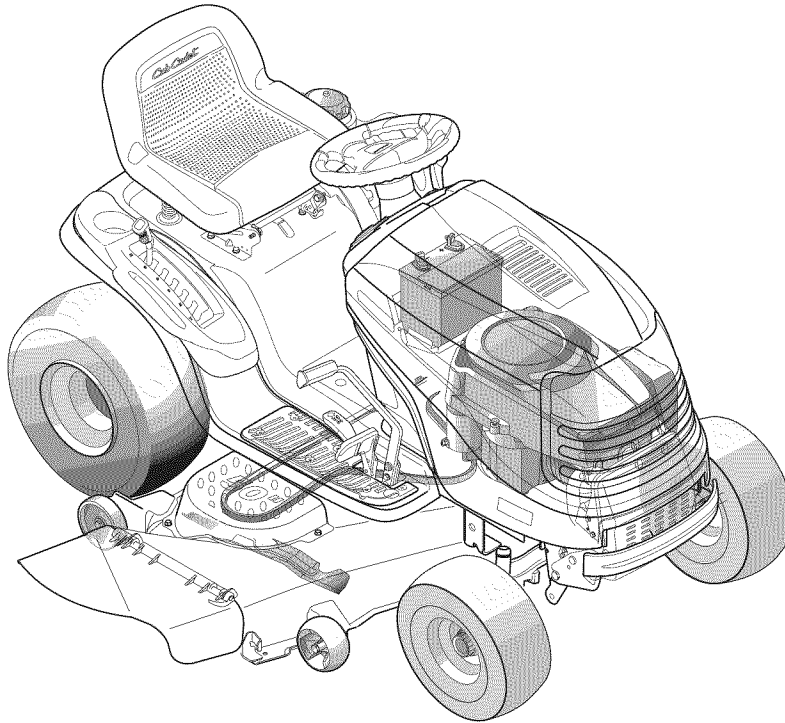

NOTE: Phone (800) 965-4CUB to order replacement parts or a complete Parts Manual (have your full model number and serial number ready). Parts Manual downloads are also available free of charge at www.cubcadet.com.

	LT1042	LT1045	LT1046	LT1050
Spark Plug (<i>Champion</i> RC12YC)	759-3336	759-3336	759-3336 (Qty. 2)	759-3336 (Qty. 2)
Air Filter – Paper Element	KH-20-083-02-S	KH-20-083-02-S	KH-32-083-03-S	KH-32-083-03-S
Air Filter – Foam Precleaner	KH-20-083-03-S	KH-20-083-03-S	KH-32-083-05-S	KH-32-083-05-S
Oil Filter	KH-25-050-25-S	KH-25-050-25-S	KH-25-050-25-S	KH-25-050-25-S
Fuel Filter	KH-25-050-22-S	KH-25-050-22-S	KH-25-050-22-S	KH-25-050-22-S
Drive Belt (Transmission)	954-0461	954-0461	7954-0461	954-0461
Drive Belt (Mowing Deck)	954-04045	754-04153	754-04153	954-04077
Deck Blade	942-04126 (Qty. 2)	942-04125 (Qty. 2) 942-04124 (Qty. 1)	942-04125 (Qty. 2) 942-04124 (Qty. 1)	942-04053A (Qty. 3)
Deck Spindle	918-0659	918-0660	918-0660	918-04126
Deck Wheel (Front)	734-04155	734-04155	734-04155	734-04155
Deck Wheel (Rear)	734-0973	734-0973	734-0973	734-0973
Battery	925-1707D	925-1707D	925-1707D	925-1707D
Tire (Front)	734-04140	734-04140	734-04140	734-04140
Tire (Rear)	734-04139	734-04139	734-04139	734-04139
Hub Cap	931-3020	931-3020	931-3020	931-3020
Fuel Tank Cap	951-3124B	951-3124B	951-3124B	951-3124B
Choke Control/Cable	746-04121	746-04121	746-04120	746-04120
Throttle Control/Cable	746-1087	746-1087	746-04352	746-04352
Discharge Chute Assembly	931-1032B	931-1032B	931-1032B	631-04070A



WARNING: If a safety feature is not functioning properly, do *not* use the tractor. Contact your *Cub Cadet* Dealer or call (800) 965-4CUB.

SECTION 15: SPECIFICATIONS*

	LT1042	LT1045	LT1046	LT1050
Capacities				
Fuel Tank	3.5 gal. (13.2 liters)	3.5 gal. (13.2 liters)	3.5 gal. (13.2 liters)	3.5 gal. (13.2 liters)
Engine Crankcase (w/ filter)	50.75 oz. (1.5 liters)	50.75 oz. (1.5 liters)	57.5 oz. (1.7 liters)	57.5 oz. (1.7 liters)
Transmission	76 oz. (2.25 liters)	76 oz. (2.25 liters)	76 oz. (2.25 liters)	76 oz. (2.25 liters)
Hydrostatic Transmission				
Make and Model	<i>Hydro-Gear 0510</i>	<i>Hydro-Gear 0510</i>	<i>Hydro-Gear 0510</i>	<i>Hydro-Gear 0510</i>
Gear Ratio	22.2:1	22.2:1	22.2:1	22.2:1
Forward Speed	0 m.p.h. - 5.2 m.p.h.	0 m.p.h. - 5.2 m.p.h.	0 m.p.h. - 5.2 m.p.h.	0 m.p.h. - 5.2 m.p.h.
Reverse Speed	0 m.p.h. - 2.3 m.p.h.	0 m.p.h. - 2.3 m.p.h.	0 m.p.h. - 2.3 m.p.h.	0 m.p.h. - 2.3 m.p.h.
Engine (Air-cooled, 4-cycle)				
Make	<i>Kohler Courage</i>	<i>Kohler Courage</i>	<i>Kohler Courage</i>	<i>Kohler Courage</i>
Model	SV590	SV600	SV720	SV720
Cylinders	Single	Single	Twin	Twin
Bore	3.70 in. (94 mm)	3.70 in. (94 mm)	3.27 in. (83 mm)	3.27 in. (83 mm)
Stroke	3.38 in. (86 mm)	3.38 in. (86 mm)	2.64 in. (67 mm)	2.64 in. (67 mm)
Displacement	36.4 cubic in. (597 cc)	36.4 cubic in. (597 cc)	44.2 cubic in. (725 cc)	44.2 cubic in. (725 cc)
Power @3600 RPM	19 HP (14.1 kW)**	20 HP (14.9 kW)**	23 HP (17.2 kW)**	23 HP (17.2 kW)**
Maximum Torque	36 ft. lb. (48.8 Nm) @ 2200 RPM	36.9 ft. lb. (50.0 Nm) @ 2200 RPM	44.9 ft. lb. (60.9 Nm) @ 2000 RPM	44.9 ft. lb. (60.9 Nm) @ 2000 RPM
Compression Ratio	8.5:1	8.5:1	9:0:1	9:0:1
Engine Speed (governed)	3375 RPM	3375 RPM	3375 RPM	3375 RPM
Low Speed	2150 RPM (± 75 RPM)	2150 RPM (± 75 RPM)	1200 RPM (± 75 RPM)	1200 RPM (± 75 RPM)
Spark Plug Gap	.030 in. (.76 mm)	.030 in. (.76 mm)	.030 in. (.76 mm)	.030 in. (.76 mm)
Electrical System				
System Voltage	12-volt Negative Ground	12-volt Negative Ground	12-volt Negative Ground	12-volt Negative Ground
Battery	190 CCA (sealed)	190 CCA (sealed)	235 CCA (sealed)	235 CCA (sealed)
Alternator	15 Amp Regulated	15 Amp Regulated	15 Amp Regulated	15 Amp Regulated
Fuse (automotive type)	20 Amp	20 Amp	20 Amp	20 Amp
Headlights	Incandescent	Incandescent	Incandescent	Incandescent
Brakes	Single Disc (Dry)	Single Disc (Dry)	Single Disc (Dry)	Single Disc (Dry)
Turf Tires				
Front (inches)	15 x 6 x 6	15 x 6 x 6	15 x 6 x 6	15 x 6 x 6
Rear (inches)	20 x 10 x 8	20 x 10 x 8	20 x 10 x 8	20 x 10 x 8
Dimensions				
Cutting Width, Deck	42 in. (106.7 cm)	46 in. (116.8 cm)	46 in. (116.8 cm)	50 in. (127.0 cm)
Wheelbase	46 in. (116.8 cm)	46 in. (116.8 cm)	46 in. (116.8 cm)	46 in. (116.8 cm)
Length, over all	68 in. (172.7 cm)	68 in. (172.7 cm)	68 in. (172.7 cm)	68 in. (172.7 cm)
Width, over all	45 in. (114.3 cm)	49 in. (124.4 cm)	49 in. (124.4 cm)	54 in. (137.2 cm)
Height, over all	43 in. (109.2 cm)	43 in. (109.2 cm)	43 in. (109.2 cm)	43 in. (109.2 cm)
Ground Clearance	4.5 in. (11.4 cm)	4.5 in. (11.4 cm)	4.5 in. (11.4 cm)	4.5 in. (11.4 cm)
Turning Radius	18 in. (46 cm)	18 in. (46 cm)	18 in. (46 cm)	18 in. (46 cm)
Weight (approximate)	498 lb. (225.9 kg)	498 lb. (225.9 kg)	501 lb. (227.25 kg.)	525 lb. (238 kg.)

* *Cub Cadet* reserves the right to change product specifications, design, and standard equipment without notice and without incurring obligation

** *Kohler's* horsepower ratings exceed Society of Automotive Engineers Small Engine Test Code J1940. Actual engine horsepower is lower and affected by, but not limited to, accessories (air cleaner, exhaust, charging, cooling, fuel pump, etc.), application, engine speed and ambient operating conditions (temperature, humidity, and altitude).

CALIFORNIA EMISSION CONTROL WARRANTY STATEMENT YOUR WARRANTY RIGHTS AND OBLIGATIONS

The California Air Resources Board and MTD Consumer Group Inc. are pleased to explain the evaporative emission control system warranty on your 2007 lawn mower. In California, new lawn mower must be designed, built and equipped to meet the State's stringent anti-smog standards. MTD Consumer Group Inc. must warrant the EECS on your lawn mower for the period of time listed below provided there has been no abuse, neglect or improper maintenance of your lawn mower.

Your EECS may include parts such as the carburetor, fuel-injection system, the ignition system, catalytic converter, fuel tanks, fuel lines, fuel caps, valves, canisters, filters, vapor hoses, clamps, connectors, and other associated emission-related components.

Where a warrantable condition exists, MTD Consumer Group Inc. will repair your lawn mower at no cost to you including diagnosis, parts and labor.

MANUFACTURER'S WARRANTY COVERAGE:

This evaporative emission control system is warranted for two years. If any evaporative emission-related part on your equipment is defective, the part will be repaired or replaced by MTD Consumer Group Inc.

OWNER'S WARRANTY RESPONSIBILITIES:

As the lawn mower owner, you are responsible for performance of the required maintenance listed in your owner's manual. MTD Consumer Group Inc. recommends that you retain all receipts covering maintenance on your lawn mower, but MTD Consumer Group Inc. cannot deny warranty solely for the lack of receipts.

As the lawn mower owner, you should however be aware that MTD Consumer Group Inc. may deny you warranty coverage if your lawn mower or a part has failed due to abuse, neglect, or improper maintenance or unapproved modifications.

You are responsible for presenting your lawn mower to MTD Consumer Group Inc.'s distribution center or service center as soon as the problem exists. The warranty repairs should be completed in a reasonable amount of time, not to exceed 30 days. If you have a question regarding your warranty coverage, you should contact your local Cub Cadet dealer. To reach the MTD Consumer Group Inc. Service Department, please call (800) 800-7310.

GENERAL EMISSIONS WARRANTY COVERAGE:

MTD Consumer Group Inc. warrants to the ultimate purchaser and each subsequent purchaser that the lawn mower is: Designed, built and equipped so as to conform with all applicable regulations; and free from defects in materials and workmanship that cause the failure of a warranted part to be identical in all material respects to that part as described in MTD Consumer Group Inc.'s application for certification.

The warranty period begins on the date the lawn mower is delivered to an ultimate purchaser or first placed into service. The warranty period is two years.

Subject to certain conditions and exclusions as stated below, the warranty on emission-related parts is as follows:

1. Any warranted part that is not scheduled for replacement as required maintenance in the written instructions supplied, is warranted for the warranty period stated above. If the part fails during the period of warranty coverage, the part will be repaired or replaced by MTD Consumer Group Inc. according to subsection (4) below. Any such part repaired or replaced under warranty will be warranted for the remainder of the period.
2. Any warranted part that is scheduled only for regular inspection in the written instructions supplied is warranted for the warranty period stated above. Any such part repaired or replaced under warranty will be warranted for the remaining warranty period.
3. Any warranted part that is scheduled for replacement as required maintenance in the written instructions supplied is warranted for the period of time before the first scheduled replacement date for that part. If the part fails before the first scheduled replacement, the part will be repaired or replaced by MTD Consumer Group Inc. according to subsection (4) below. Any such part repaired or replaced under warranty will be warranted for the remainder of the period prior to the first scheduled replacement point for the part.
4. Repair or replacement of any warranted part under the warranty provisions herein must be performed at a warranty station at no charge to the owner.
5. Notwithstanding the provisions herein, warranty services or repairs will be provided at all of our distribution centers that are franchised to service the subject engines or equipment.
6. The lawn mower owner will not be charged for diagnostic labor that is directly associated with diagnosis of a defective, emission-related warranted part, provided that such diagnostic work is performed at a warranty station.
7. MTD Consumer Group Inc. is liable for damages to other engine or equipment components proximately caused by a failure under warranty of any warranted part.
8. Throughout the lawn mower warranty period stated above, MTD Consumer Group Inc. will maintain a supply of warranted parts sufficient to meet the expected demand for such parts.
9. Any replacement part may be used in the performance of any warranty maintenance or repairs and must be provided without charge to the owner. Such use will not reduce the warranty obligations of MTD Consumer Group Inc.
10. Add-on or modified parts that are not exempted by the Air Resources Board may not be used. The use of any non-exempted add-on or modified parts by the ultimate purchaser will be grounds for disallowing a warranty claims. MTD Consumer Group Inc. will not be liable to warrant failures of warranted parts caused by the use of a non-exempted add-on or modified part.

WARRANTED PARTS:

The repair or replacement of any warranted part otherwise eligible for warranty coverage may be excluded from such warranty coverage if MTD Consumer Group Inc. demonstrates that the lawn mower has been abused, neglected, or improperly maintained, and that such abuse, neglect, or improper maintenance was the direct cause of the need for repair or replacement of the part. That notwithstanding, any adjustment of a component that has a factory installed, and properly operating, adjustment limiting device is still eligible for warranty coverage. The following emission warranty parts list are covered: Fuel Line, Fuel Line Clamps

**KOHLER CO.
FEDERAL AND CALIFORNIA EMISSION CONTROL SYSTEMS
LIMITED WARRANTY
UTILITY AND LAWN AND GARDEN ENGINES**

The U.S. Environmental Protection Agency (EPA), the California Air Resources Board (CARB), and Kohler Co. are pleased to explain the Federal and California Emission Control Systems Warranty on your small off-road equipment engine. For California, engines produced in 1995 and later must be designed, built and equipped to meet the state's stringent anti-smog standards. In other states, 1997 and later model year engines must be designed, built and equipped, to meet the U.S. EPA regulations for small non-road engines. The engine must be free from defects in materials and workmanship which cause it to fail to conform with U.S. EPA standards for the first two years of engine use from the date of sale to the ultimate purchaser. Kohler Co. must warrant the emission control system on the engine for the period of time listed above, provided there has been no abuse, neglect or improper maintenance.

The emission control system may include parts such as the carburetor or fuel injection system, the ignition system, and catalytic converter. Also included are the hoses, belts and connectors and other emission related assemblies.

Where a warrantable condition exists, Kohler Co. will repair the engine at no cost, including diagnosis (if the diagnostic work is performed at an authorized dealer), parts and labor.

MANUFACTURER'S WARRANTY COVERAGE

Engines produced in 1995 or later are warranted for two years in California. In other states, 1997 and later model year engines are warranted for two years. If any emission related part on the engine is defective, the part will be repaired or replaced by Kohler Co. free of charge.

OWNER'S WARRANTY RESPONSIBILITIES

The engine owner is responsible for the performance of the required maintenance listed in the owner's manual. Kohler Co. recommends that you retain all receipts covering maintenance on the engine. But Kohler Co. cannot deny warranty solely for the lack of receipts or for your failure to assure that all scheduled maintenance was performed.

- (a) Be aware, however, that Kohler Co. may deny warranty coverage if the engine or a part has failed due to abuse, neglect, improper maintenance or unapproved modifications.
- (b) For warranty repairs, the engine must be presented to a Kohler Co. service center as soon as a problem exists. Call 1-800-544-2444, or access our web site at: www.kohlerengines.com, for the names of the nearest service centers. The warranty repairs should be completed in a reasonable amount of time, not to exceed 30 days.

If you have any questions regarding warranty rights and responsibilities, you should contact Kohler Co. at 1-920-457-4441 and ask for an Engine Service representative.

COVERAGE

Kohler Co. warrants to the ultimate purchaser and each subsequent purchaser that the engine will be designed, built and equipped, at the time of sale, to meet all applicable regulations. Kohler Co. also warrants to the initial purchaser and each subsequent purchaser, that the engine is free from defects in material and workmanship which cause the engine to fail to conform with applicable regulations for a period of two years.

Engines produced in 1995 or later are warranted for two years in California. For 1997 and later model years, EPA requires manufacturers to warrant engines for two years in all other states. These warranty periods will begin on the date the engine is purchased by the initial purchaser. If any emission related part on the engine is defective, the part will be replaced by Kohler Co. at no cost to the owner. Kohler Co. is liable for damages to other engine components caused by the failure of a warranted part still under warranty.

Kohler Co. shall remedy warranty defects at any authorized Kohler Co. engine dealer or warranty station. Warranty repair work done at an authorized dealer or warranty station shall be free of charge to the owner if such work determines that a warranted part is defective.

Listed below are the parts covered by the Federal and California Emission Control Systems Warranty. Some parts listed below may require scheduled maintenance and are warranted up to the first scheduled replacement point for that part. The warranted parts are:

- Oxygen sensor (if equipped)
- Exhaust manifold (if equipped)
- Fuel metering valve (if equipped)
- Crankcase breather
- Gaseous fuel regulator (if equipped)
- Carburetor or fuel injection system
- Air filter, fuel filter, and spark plugs (only to first scheduled replacement point)
- Intake manifold (if equipped)
- Catalytic muffler (if equipped)
- Spark advance module (if equipped)
- Ignition module(s) with high tension lead
- Electronic control unit (if equipped)
- Fuel lines (if equipped)

LIMITATIONS

This Emission Control System Warranty shall not cover any of the following:

- (a) repair or replacement required because of misuse or neglect, improper maintenance, repairs improperly performed or replacement not conforming to Kohler Co. specifications that adversely affect performance and/or durability and alterations or modifications not recommended or approved in writing by Kohler Co.,
- (b) replacement of parts and other services and adjustments necessary for required maintenance at and after the first scheduled replacement point,
- (c) consequential damages such as loss of time, inconvenience, loss of use of the engine or equipment, etc.,
- (d) diagnosis and inspection fees that do not result in eligible warranty service being performed, and
- (e) any add-on or modified part, or malfunction of authorized parts due to the use of add-on or modified parts.

MAINTENANCE AND REPAIRS REQUIREMENTS

The owner is responsible for the proper use and maintenance of the engine. Kohler Co. recommends that all receipts and records covering the performance of regular maintenance be retained in case questions arise. If the engine is resold during the warranty period, the maintenance records should be transferred to each subsequent owner. Kohler Co. reserves the right to deny warranty coverage if the engine has not been properly maintained; however, Kohler Co. may not deny warranty repairs solely because of the lack of repair maintenance or failure to keep maintenance records.

Normal maintenance, replacement or repair of emission control devices and systems may be performed by any repair establishment or individual; however, **warranty repair must be performed by a Kohler authorized service center.** Any replacement part or service that is equivalent in performance and durability may be used in non-warranty maintenance or repairs, and shall not reduce the warranty obligations of the engine manufacturer.

CUB CADET LLC
MANUFACTURER'S LIMITED WARRANTY FOR
SERIES 1000 & SERIES 1500 TRACTORS

IMPORTANT: To obtain warranty coverage owner must present an original proof of purchase and applicable maintenance records to the servicing dealer. Please see the operator's manual for information on required maintenance and service intervals.

The limited warranty set forth below is given by Cub Cadet LLC with respect to new merchandise purchased or leased and used in the

United States and/or its territories and possessions, and by MTD Products Limited with respect to new merchandise purchased or leased and used in Canada and/or its territories and possessions (either entity respectively, "Cub Cadet").

Cub Cadet warrants this product (excluding its *Normal Wear Parts, Batteries, and Frame and Front Axle* as described below) against defects in material and workmanship for a period of three (3) years or one hundred twenty (120) operation hours, whichever comes first, commencing on the date of original retail purchase or lease and will, at its option, repair or replace, free of charge, any part found to be defective in materials or workmanship.

Normal Wear Parts are warranted to be free from defects in material and workmanship for a period of thirty (30) days from the date of original purchase or lease. Normal wear parts include, but are not limited to items such as: belts, blades, blade adapters, grass bags, rider deck wheels, seats, and tires.

Batteries have a one-year prorated limited warranty against defects in material and workmanship, with 100% replacement during the first three months. After three months, the battery replacement credit is based on the months remaining in the twelve (12) month period dating back to the original date of original sale or lease. Any replacement battery will be warranted only for the remainder of the original warranty period.

Frame and Front Axle — Cub Cadet warrants the frame, and front cast iron pivot axle against defects in material and workmanship for a period of five (5) years or 500 hours, whichever occurs first, commencing on the date of original purchase or lease.

This limited warranty shall only apply if this product has been operated and maintained in accordance with the Operator's Manual furnished with the product, and has not been subject to misuse, abuse, commercial use, neglect, accident, improper maintenance, alteration, vandalism, theft, fire, water, or damage because of other peril or natural disaster. Damage resulting from the installation or use of any part, accessory or attachment not approved by Cub Cadet for use with the product(s) covered by this manual will void your warranty as to any resulting damage. In addition, Cub Cadet may deny warranty coverage if the hour meter, or any part thereof, is altered, modified, disconnected or otherwise tampered with.

HOW TO OBTAIN SERVICE: Warranty service is available, WITH PROOF OF PURCHASE AND APPLICABLE MAINTENANCE RECORDS, through your local authorized service dealer. To locate the dealer in your area:

In the U.S.A.:

Check your Yellow Pages, or contact Cub Cadet LLC at P.O. Box 361131, Cleveland, Ohio 44136-0019, call 1-877-282- 8684 or log on to our website at www.cubcadet.com.

In Canada:

Contact MTD Products Limited, Kitchener, ON N2G 4J1, call 1-800-668-1238 or log on to our website at www.mtdcanada.com.

Without limiting the foregoing, this limited warranty does not provide coverage in the following cases:

- a. Routine maintenance items such as lubricants, filters, blade sharpening, tune-ups, brake adjustments, clutch adjustments, deck adjustments, and normal deterioration of the exterior finish due to use or exposure.
- b. Service completed by someone other than an authorized service dealer.
- c. Cub Cadet does not extend any warranty for products sold or exported outside of the United States and/or Canada, and their respective possessions and territories, except those sold through Cub Cadet's authorized channels of export distribution.
- d. Replacement parts and/or accessories that are not genuine Cub Cadet parts.
- e. Transportation charges and service calls.
- f. Cub Cadet does not warrant this product for commercial use.

There are no implied warranties, including without limitation any implied warranty of merchantability or fitness for a particular purpose. No warranties shall apply after the applicable period of express written warranty above. No other express warranties beyond those mentioned above, given by any person or entity, including a dealer or retailer, with respect to any product, shall bind Cub Cadet. The exclusive remedy is repair or replacement of the product as set forth above. The terms of this warranty provide the sole and exclusive remedy arising from the sale and/or lease of the products covered hereby. Cub Cadet shall not be liable for any incidental or consequential loss or damage including, without limitation, expenses incurred for substitute or replacement lawn care services or for rental expenses to temporarily replace a warranted product.

Some jurisdictions do not allow the exclusion or limitation of incidental or consequential damages, or limitations on how long an implied warranty lasts, so the above exclusions or limitations may not apply to you.

In no event shall recovery of any kind be greater than the amount of the purchase price of the product sold. Alteration of safety features of the product shall void this warranty. You assume the risk and liability for loss, damage, or injury to you and your property and/or to others and their property arising out of the misuse or inability to use the product.

This limited warranty shall not extend to anyone other than the original purchaser or to the person for whom it was purchased as a gift.

HOW LOCAL LAWS RELATE TO THIS WARRANTY: This limited warranty gives you specific legal rights, and you may also have other rights that vary in different jurisdictions.

CUB CADET LLC, P.O. BOX 361131 CLEVELAND, OHIO 44136-0019