

SEARS

OWNERS
MANUAL

Model No.
171 25468



DP70999

PARTS LIST

CRAFTSMAN® GUIDE MASTER™ ROUTER TABLE PUSH SHOE

- Assembly
- Operation

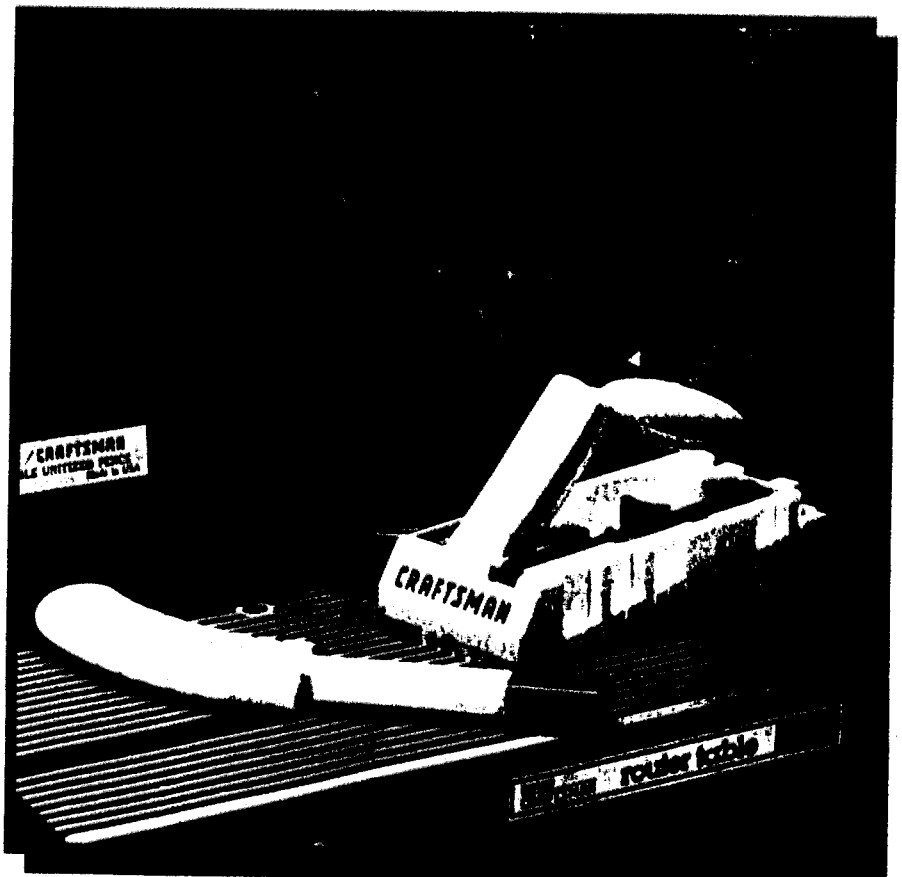

**READ AND FOLLOW
ALL INSTRUCTIONS
CAREFULLY.
KEEP THIS MANUAL
FOR FUTURE
REFERENCE.**

Sold by Sears, Roebuck and Co., Hoffman Estates, IL. 60179

FAILURE TO HEED ALL SAFETY AND OPERATING INSTRUCTIONS AND WARNINGS REGARDING USE OF THIS PRODUCT CAN RESULT IN SERIOUS BODILY INJURY.

GENERAL SAFETY INSTRUCTIONS FOR POWER TOOLS

1) KNOW YOUR POWER TOOL

Read the owner's manual carefully. Learn its applications and limitations as well as the specific potential hazards particular to this tool.

2) GROUND ALL TOOLS (UNLESS DOUBLE INSULATED)

If tool is equipped with an approved 3-conductor cord and a 3-prong grounding type plug, it should be plugged into a three hole electrical receptacle. If adapter is used to accommodate a two-prong receptacle, the adapter wire must be attached to known ground, (usually the screw securing receptacle cover plate). Never remove third prong. Never connect green ground wire to a terminal.

3) KEEP GUARDS IN PLACE

in working order, and in proper adjustment and alignment.

4) REMOVE ADJUSTING KEYS AND WRENCHES

Form a habit of checking to see that keys and adjusting wrenches are removed from tool before turning it on.

5) KEEP WORK AREA CLEAN

Cluttered areas and benches invite accidents. Floor must not be slippery due to wax or sawdust.

6) AVOID DANGEROUS ENVIRONMENT

Do not use power tools in damp or wet locations or expose them to rain. Keep work area well lighted. Provide adequate surrounding work space.

7) KEEP CHILDREN AWAY

All visitors should be kept at a safe distance from work area.

8) MAKE WORKSHOP CHILD-PROOF

—with padlocks, master switches, or by removing starter keys.

9) DO NOT FORCE TOOL

It will do the job better and safer at the rate for which it was designed.

10) USE APPROPRIATE TOOL

Do not force tool or attachment to do a job for which it was not designed.

11) WEAR APPROPRIATE APPAREL

Do not wear loose clothing, gloves, neckties or jewelry (rings, wristwatches) to get caught in moving parts. Non-slip footwear is recommended. Wear protective hair covering to contain long hair. Roll long sleeves above the elbow.

12) USE SAFETY GOGGLES (Head Protection)

Wear Safety Goggles (must comply with ANSI Z87.1) at all times. Also, use face or dust mask if cutting operating is dusty, and ear protectors (plugs or muffs) during extended periods of operation.

13) SECURE WORK

Use clamps or a vise to hold work when practical. It's safer than using your hand and frees both hands to operate tool.

14) DO NOT OVERREACH

Keep proper footing and balance at all times.

15) MAINTAIN TOOLS WITH CARE

Keep tools sharp and clean for best and safest performance. Follow instructions for lubricating and changing accessories.

16) DISCONNECT TOOLS BEFORE SERVICING

—when changing accessories such as blades, bits, cutters, etc.

17) AVOID ACCIDENTAL STARTING

Make sure switch is in OFF position before plugging in.

18) USE RECOMMENDED ACCESSORIES

Consult the owner's manual for recommended accessories. Follow the instructions that accompany the accessories. The use of improper accessories may cause hazards.

19) NEVER STAND ON TOOL

Serious injury could occur if the tool is tipped or the cutting tool is accidentally contacted. Do not store materials above or near the tool that would make it necessary to stand on the tool to reach them.

20) CHECK DAMAGED PARTS

Before further use of the tool, a guard or other part that is damaged should be carefully checked to ensure that it will operate properly and perform its intended function. Check for alignment of moving parts, binding of moving parts, breakage of parts, mounting, and any other conditions that may affect its operation. A guard or other part that is damaged should be properly repaired or replaced.

21) DIRECTION OF FEED

Feed work into a blade or cutter only against the direction of rotation of the blade or cutter.

22) NEVER LEAVE TOOL RUNNING UNATTENDED

Turn power off. Do not leave tool until it comes to a complete stop.

READ AND UNDERSTAND THIS COMPLETE INSTRUCTION BOOK BEFORE USING THIS PRODUCT.

23) KEEP HANDS AWAY FROM CUTTING AREA

24) STORE IDLE TOOLS

When not in use, tools should be stored in dry, high or locked-up place—out of reach of children.

25) DO NOT ABUSE CORD

Keep cord away from heat, oil, and sharp edges.

26) OUTDOOR EXTENSION CORDS

When tool is used outdoors, use only extension cords suitable for use outdoors, and so marked.

27) NEVER USE IN AN EXPLOSIVE ATMOSPHERE

Normal sparking of the motor could ignite fumes, flammable liquids, or combustible items.

28) DRUGS, ALCOHOL, MEDICATION

Do not operate tool while under the influence of drugs, alcohol, or any medication.

INTRODUCTION

The GUIDE MASTER™ Router Table Push Shoe has been designed to help complete many of the common wood-working tasks performed on a router table. Although the push shoe can be used with any size of stock, its design has been tailored for use with thin and narrow stock. The product can be used as a straight push shoe, as a miter gauge, as a bit height gauge, to check or set fence offset distances, and as a set-up tool for making sliding dovetail joints.

USAGE LIMITATIONS

To use the push shoe as a miter gauge requires the removal of the bottom and side fences and the attachment of the miter gauge. The conversion is very easy and should not take any longer than a couple of minutes.

UNPACKING AND CHECKING CONTENTS

In order to simplify handling and to minimize any damage that may occur during shipping, your router table push shoe is packaged unassembled. Separate all parts from the packing materials and check each one with the illustration and list of parts to make sure that all parts are accounted for before discarding any packaging material.

Warning! If any parts are missing or cannot be accounted for, do not attempt to assemble, or use the push shoe until the missing parts have been obtained. Contact your local Sears retail outlet for replacement products or for the missing parts.

ASSEMBLY INSTRUCTIONS

The following tools are required to assemble this product:

- 1) A medium sized flat bladed screwdriver.
- 2) A small phillips screwdriver.
- 3) A small crescent wrench or pliers.



Read and observe all instructions in your Router and Router Table Owner's Manual before and when using this product. Never place fingers in the path of the cutter. Always wear eye protection which complies with current ANSI Standard Z87.1 FAILURE TO HEED ALL WARNINGS COULD RESULT IN SERIOUS BODILY INJURY.

Assembly of the Handle:

1) Assemble the handle to the base as shown in Fig. 1, using #10-32 pan head screw, and #10-32 hex nut. Tighten the screw securely.

Fig. 1

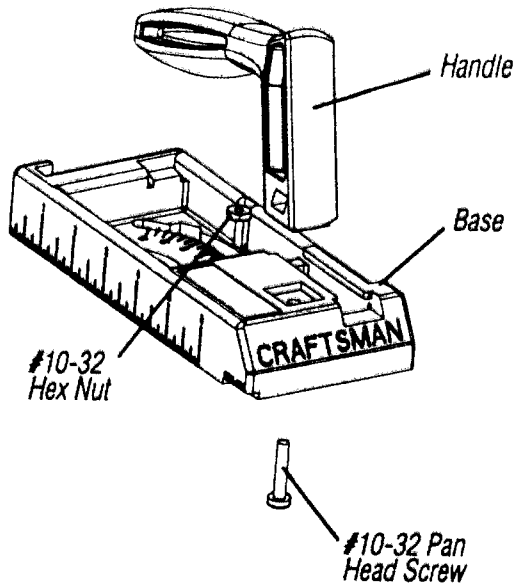

Assembly of the Adjustable Bottom Fence:

1) Assemble the adjustable bottom fence to the base as shown in Fig. 2a and 2b, using #10-24 carriage bolt, #10 washer, and 3 wing knob. Tighten the 3 wing knob. Make sure orientation of parts is as shown.

Important: Check that the adjustable bottom fence has seated properly into the bottom of the base as shown in Fig. 2b.

Fig. 2a

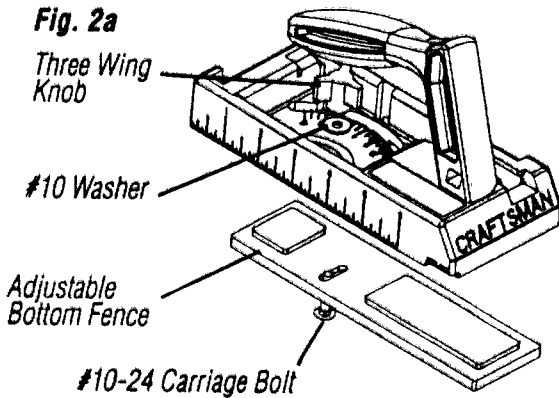
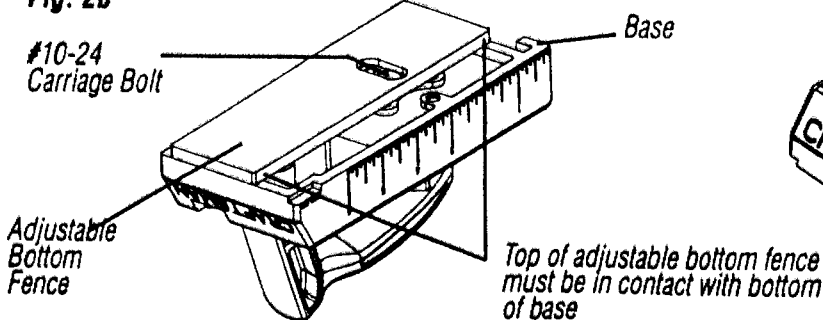

Fig. 2b



Assembly of Adjustable Side Fence:

1) Assemble the adjustable side fence to the base as shown in Fig. 3, using round knob, #10-32 hex nut, and #10 washer. Tighten the round knob.

Fig. 3

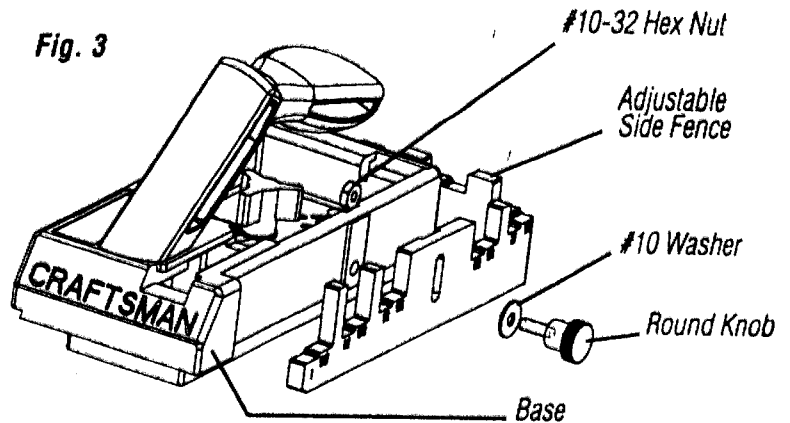

Assembly of the Miter Pointer:

1) Assemble the miter pointer and miter bar as shown in Fig. 4, using #4-40 pan head screw, and #4-40 hex nut. Tighten the screw securely.

2) Insert the miter bar assembly into the docking station on the base as shown in Fig. 5.

Note: The miter bar assembly should snap snugly into the docking station and the back of the miter bar should not protrude past the front of the base as shown in Fig. 5.

Fig. 4

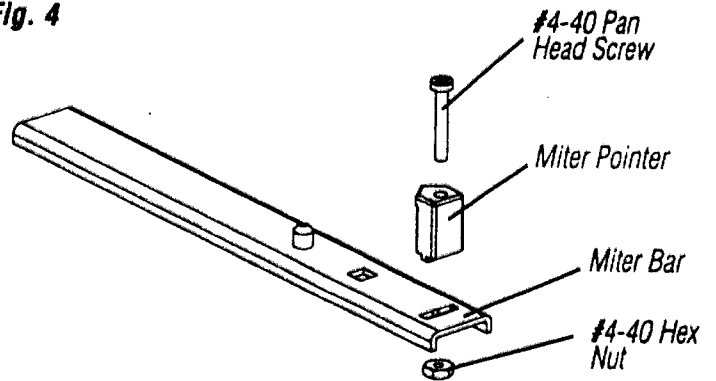
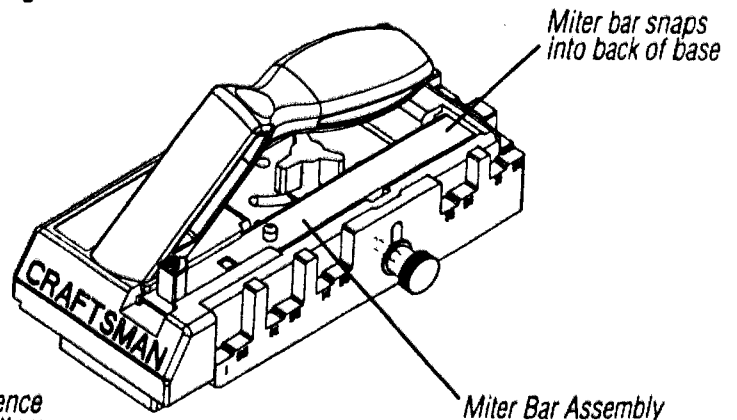
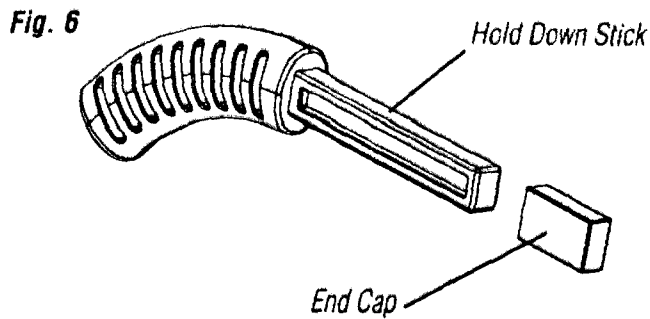

Fig. 5



Assembly of the Rubber End Cap:

1) Push the black cap all the way onto the end of the hold down stick as shown in Fig. 6.



Note: The hold down stick is sized so that the end cap will fit tightly. To make the end cap slide onto the end of the hold down stick more easily, coat the end of the hold down stick and the inside of the cap with warm soapy water before attempting to assemble.

USING THE ROUTER TABLE PUSH SHOE

Your Router Table Push Shoe can be used to complete the following tasks with a router table and router.

EDGE ROUTING

Adjusting Side and Bottom Fences:

Note: Before routing any stock the side and bottom fences need to be adjusted so that the workpiece is held securely when routing.

- 1) Adjust side fence as shown in Fig. 7, so that the thickness of the workpiece and the height of the fence are equal.
- 2) Adjust bottom fence as shown in Fig. 7, so that there is a minimum .050" overhang between the stock and the shoe. **WARNING: Failure to adjust the bottom fence with the minimum .050 overhang may cause the router bit to come in contact with the side fence or base.**

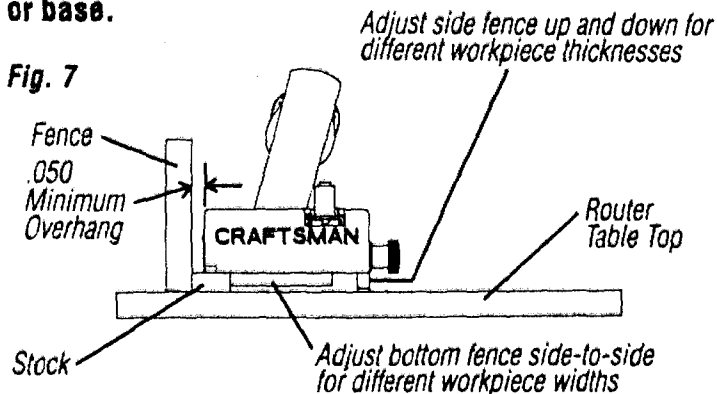

- 3) Locate stock in corner formed by bottom fence, side fence, and base. See Fig. 8.

Fig. 8

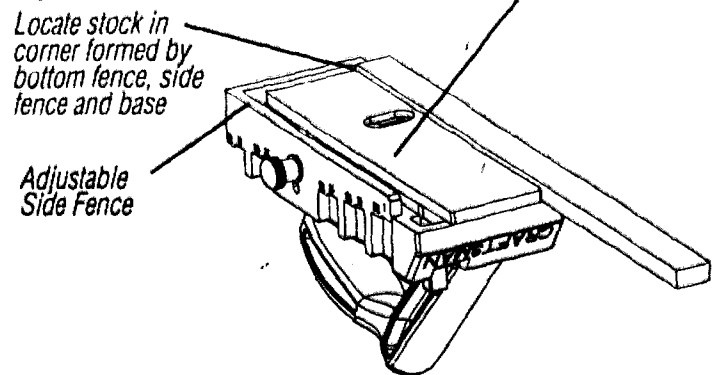

Routing Stock

Note: Feed the stock in the direction indicated on your router table.

- 1) Keep even downward pressure on the shoe handle.
- 2) Keep the stock against the router fence.
- 3) If working with longer stock, use the hold down stick to stabilize the stock as it is being fed through the cutter. See Fig. 9.

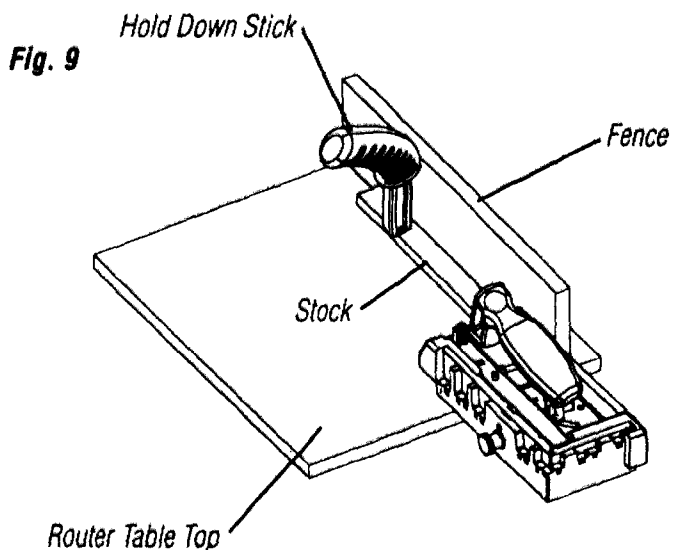

Mitering

Note: To convert the push shoe to a miter gauge is very simple and will only take a couple of minutes. The steps below will lead you through the conversion.

- 1) Remove the adjustable side and bottom fences.
- 2) Remove the miter gauge assembly from the docking station.

3) Insert the miter pointer through the window in the base as shown in Fig. 10a.

4) Rotate miter gauge so that pivot pin aligns with the pivot hole in base. Insert pivot pin into hole as shown in Fig. 10b.

Fig. 10a

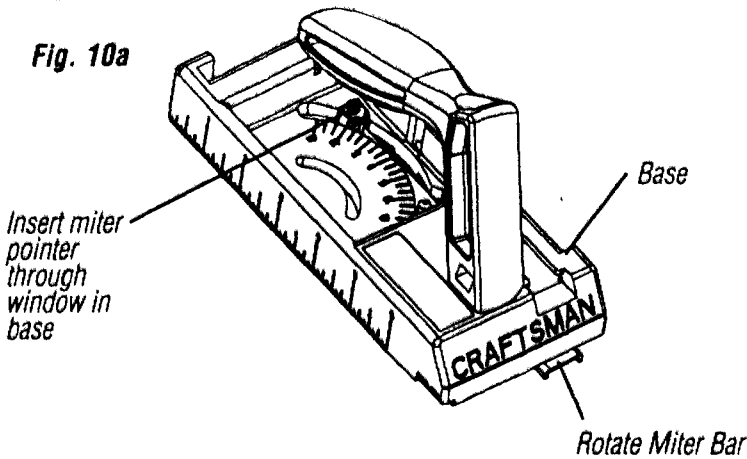
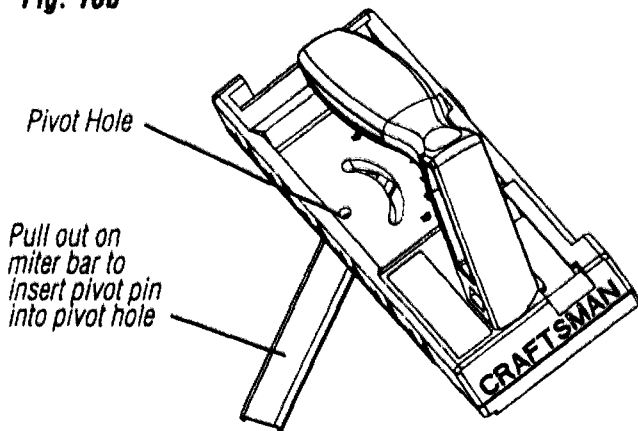
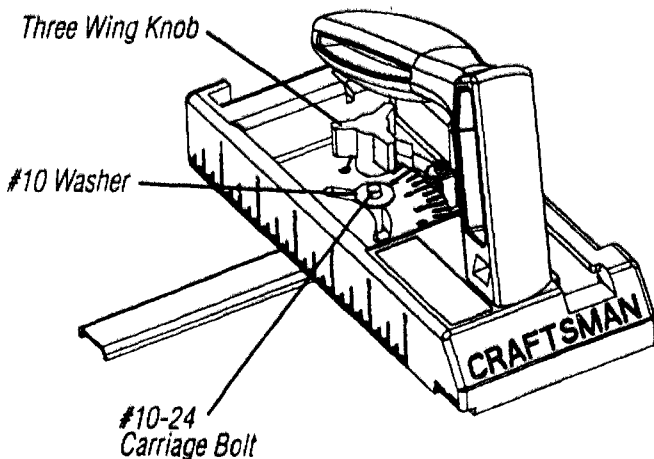

Fig. 10b



5) Attach the #10-24 carriage bolt, #10 washer, and 3 wing knob from the bottom fence as shown in Fig. 11.

Fig. 11



Bit Height Gauge

1) Remove the adjustable side fence and flip so that the numbers are right side up. Use the gauge as shown in Fig. 12 to check bit height.

Fig. 12

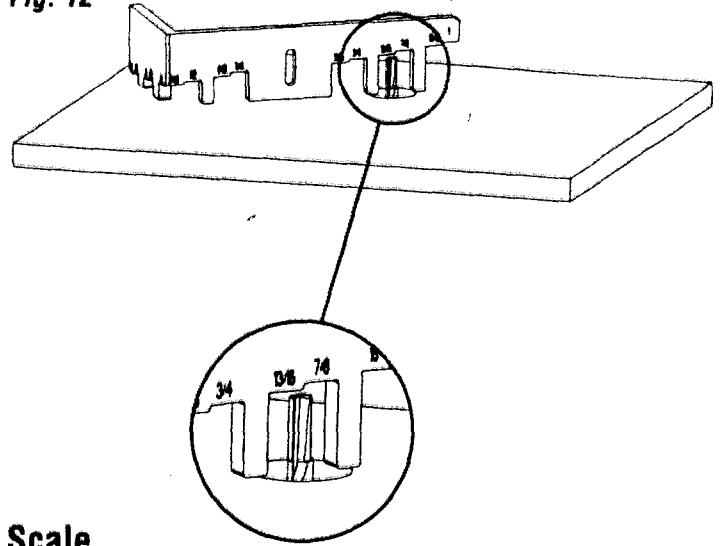

Scale

The six inch scale on the base can be used for several common tasks.

1) Setting the router table fence offset distances as shown in Fig. 13.

Line up back of base with fence

Fig. 13

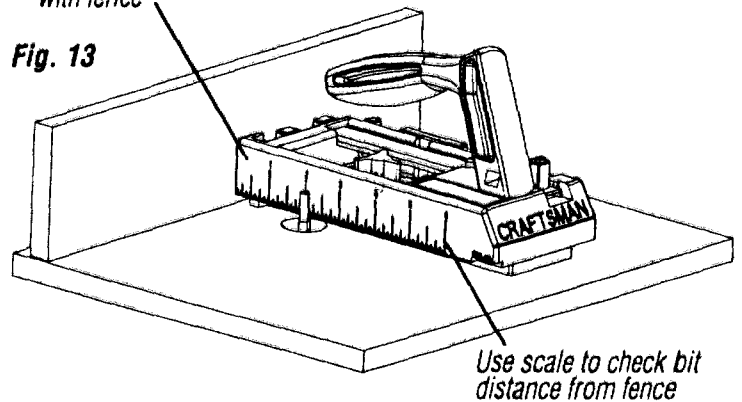

Sliding Dovetail Gauge

The base has a cut-out that has been designed so that 1/2" sliding dovetail joints can be made on your router table. The cut-out allows the fence as well as the bit height to be set-up quickly for this type of joint.

Note: The gauge is based on using 3/4" thick stock when making the male (tenon) portion of the joint. If the stock is **NOT EXACTLY** 3/4" thick the router table fence will have to be adjusted to make the joint fit together correctly.

To set-up for this joint, follow the steps below.

Set-up for the female (mortise) portion of the joint:

- 1) Set the adjustable side fence to the fully up position so that the shoe is resting on the adjustable bottom fence.
- 2) Position the shoe over the bit and raise the bit so that it touches the top of the gauge slot as shown in Fig. 14. The joint is ready to be cut. Adjust the fence, etc. for your specific application.

Set-up for the male (tenon) portion of the joint:

- 1) Set the adjustable side fence to the fully up position so that the shoe is resting on the adjustable bottom fence.
- 2) Position the shoe over the bit, raise the bit so that it touches the top and side of the gauge slot; then, move the router table fence so that it touches the side of the shoe as shown in Fig. 15. The joint is ready to be cut.

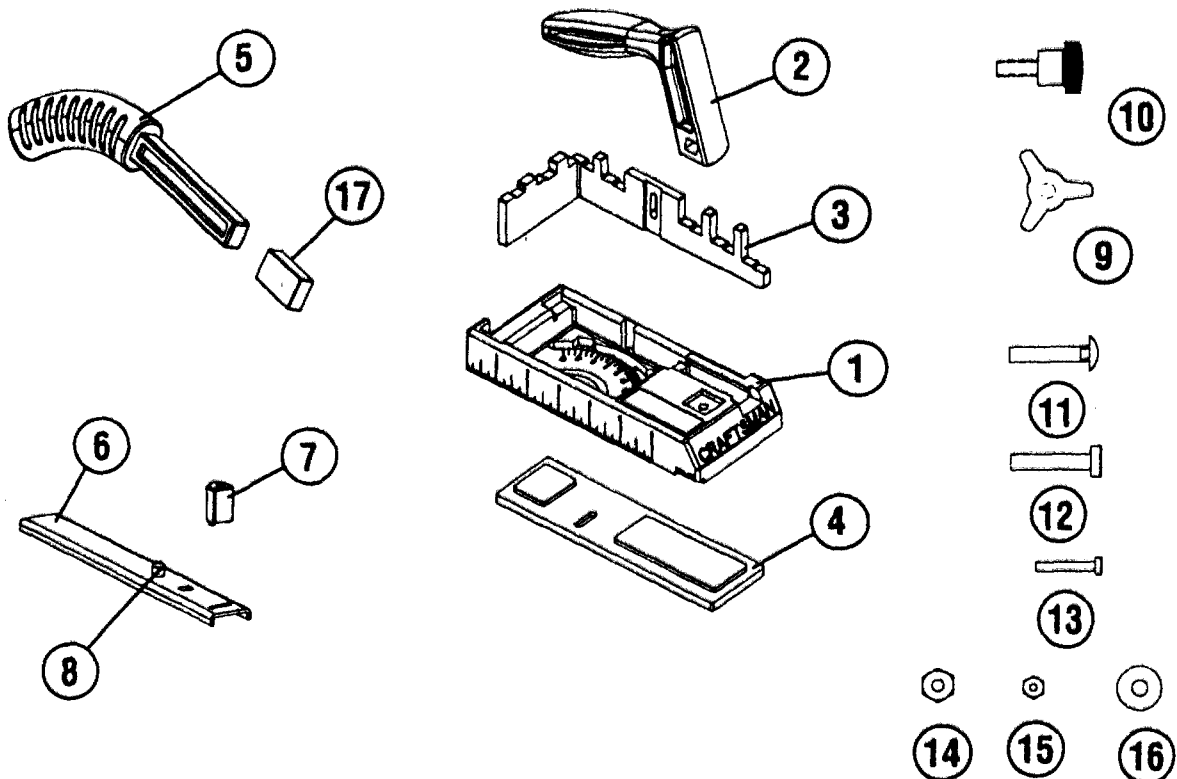
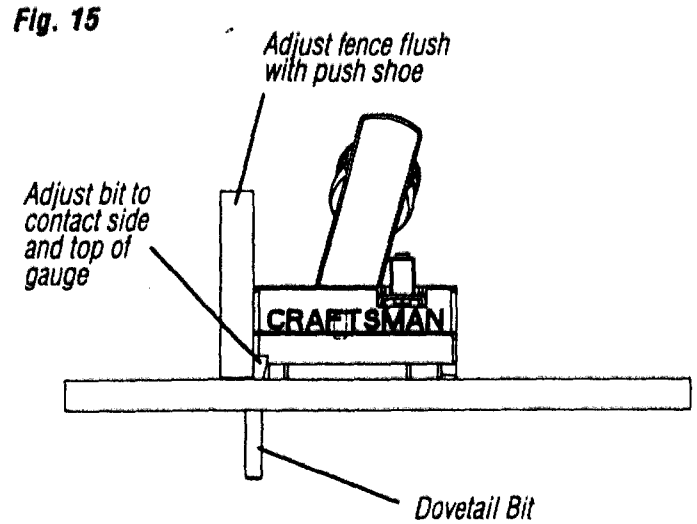
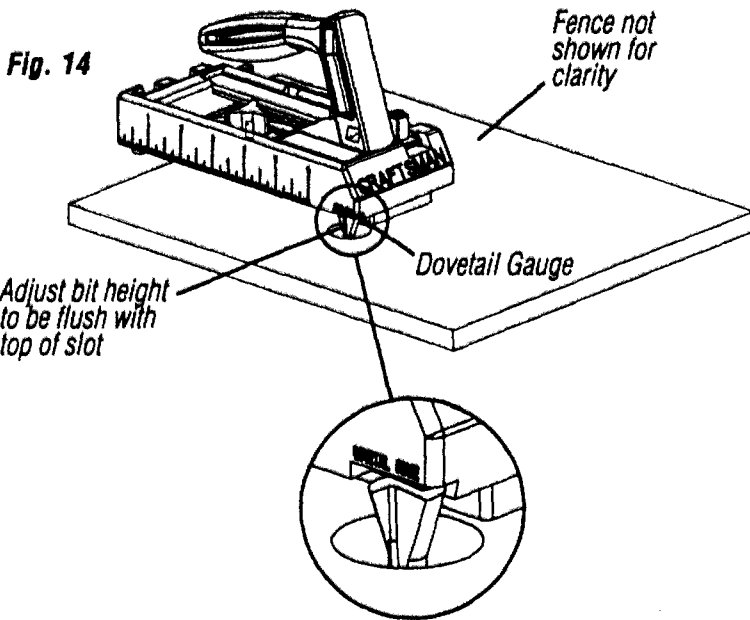

PARTS LISTS

KEY NO.	QTY	DWG.NO.	DWG SIZE	REF.NO	PART NAME
1	1	29LCN-961	D	22414	BASE
2	1	29LCN-962	D	22415	HANDLE
3	1	29LCB-963	C	22416	ADJUSTABLE SIDE FENCE
4	1	29LCN-964		22417	ADJUSTABLE BOTTOM FENCE
5	1	29LCN-965		22418	HOLD DOWN STICK
6	1	29LCN-966	B	22419	MITER BAR
7	1	29LCN-967		22420	MITER POINTER
8	1	29LCN-968		22421	PIVOT PIN
9	1	3IL-560	A	21733	3 WING KNOB
10	1	29LD-766-1	A	22219	ROUND KNOB
11	1	F29A-310-20	A	3011	#10-24 CARRIAGE BOLT
12	1	F29L-469-20		21856	#10-32 PAN HEAD SCREW
13	1	F29L-469-21	A	21856	#4-40 PAN HEAD SCREW
14	2	F29A-242-12	A	2825	#10-32 HEX NUT
15	1	F29A-242-15		2825	#4-40 HEX NUT
16	2	F29A-306-37		3007	#10 WASHER
17	1	29L-764-1		22217	RUBBER END CAP
	1				WARNING LABEL
	1				INSTRUCTION MANUAL

Printed in U.S.A.
10/95

When corresponding, always give the following information as shown in the list.

1. The PART NUMBER
 2. The PART DESCRIPTION
 3. The MODEL # 171.25468
 4. The ITEM NAME – GUIDE MASTER™ ROUTER TABLE
PUSH SHOE
-