

WESLO®

PURSUIT CT 3.8 R

Model No. 831.21811.1

Serial No. _____

Write the serial number in the space above for reference.

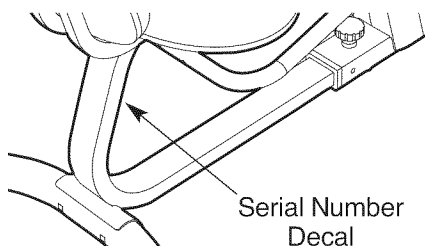

- Assembly
- Operation
- Maintenance
- Part List and Drawing

Sears, Roebuck and Co.
Hoffman Estates, IL 60179

CAUTION

Read all precautions and instructions in this manual before using this equipment. Keep this manual for future reference.

BIKE EXERCISER User's Manual

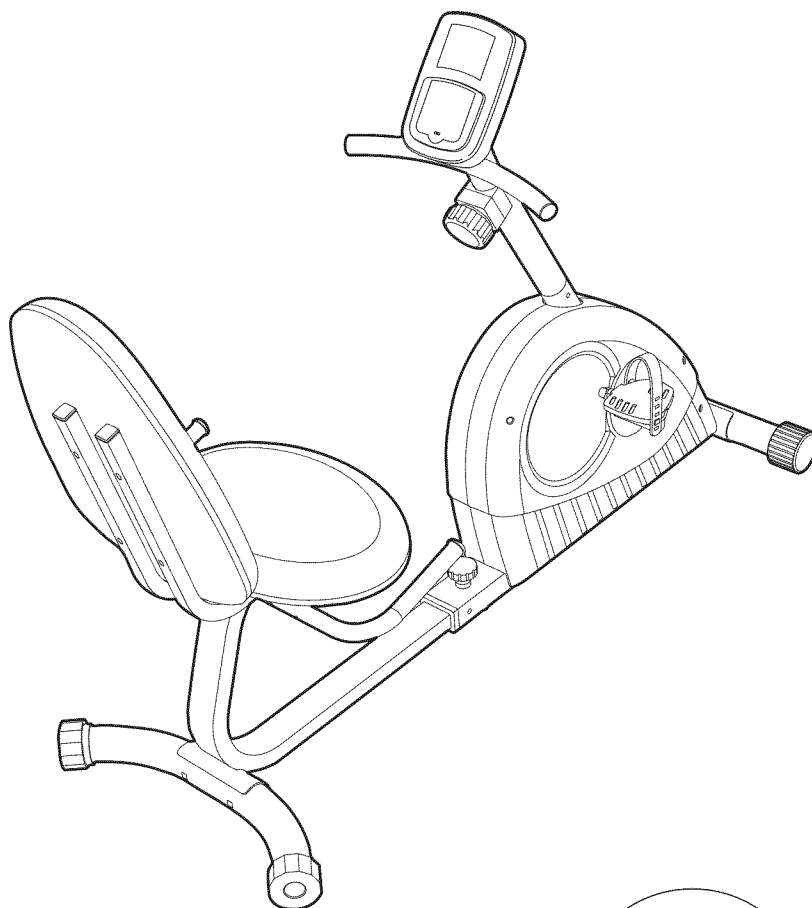

TABLE OF CONTENTS



WARNING DECAL PLACEMENT	2
IMPORTANT PRECAUTIONS	3
BEFORE YOU BEGIN	4
ASSEMBLY	5
HOW TO USE THE EXERCISE BIKE	11
MAINTENANCE AND TROUBLESHOOTING	14
FCC INFORMATION	15
EXERCISE GUIDELINES	16
PART LIST	18
EXPLODED DRAWING	19
ORDERING REPLACEMENT PARTS	Back Cover
90 DAY FULL WARRANTY	Back Cover

WARNING DECAL PLACEMENT

This drawing shows the location(s) of the warning decal(s). **If a decal is missing or illegible, call 1-866-699-3756 and request a free replacement decal. Apply the decal in the location shown.** Note: The decal(s) may not be shown at actual size.

WARNING

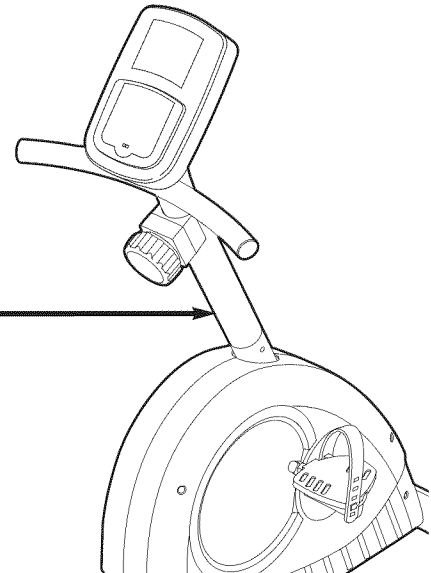
- Misuse of this machine may result in serious injury.
- Read user's manual prior to use and follow all warnings and instructions.
- Do not allow children on or around machine.
- Pedals continue to spin when you stop pedaling.
- Spinning pedals can cause injury.
- Reduce pedal speed in a controlled manner.
- User weight must not exceed 250 pounds.
- Replace label if damaged, illegible, or removed.



IMPORTANT PRECAUTIONS

⚠ WARNING: To reduce the risk of serious injury, read all important precautions and instructions in this manual and all warnings on your exercise bike before using your exercise bike. ICON assumes no responsibility for personal injury or property damage sustained by or through the use of this product.

1. Before beginning any exercise program, consult your physician. This is especially important for persons over age 35 or persons with pre-existing health problems.
2. Use the exercise bike only as described in this manual.
3. It is the responsibility of the owner to ensure that all users of the exercise bike are adequately informed of all precautions.
4. The exercise bike is intended for home use only. Do not use the exercise bike in a commercial, rental, or institutional setting.
5. Keep the exercise bike indoors, away from moisture and dust. Do not put the exercise bike in a garage or covered patio, or near water.
6. Place the exercise bike on a level surface with at least 2 ft. (0.6 m) of clearance around the exercise bike. To protect the floor or carpet from damage, place a mat under the exercise bike.
7. Inspect and properly tighten all parts regularly. Replace any worn parts immediately.
8. Keep children under age 12 and pets away from the exercise bike at all times.
9. The exercise bike should not be used by persons weighing more than 250 lbs. (113 kg).
10. Wear appropriate clothes while exercising; do not wear loose clothes that could become caught on the exercise bike. Always wear athletic shoes for foot protection.
11. The pulse sensor is not a medical device. Various factors, including the user's movement, may affect the accuracy of heart rate readings. The pulse sensor is intended only as an exercise aid in determining heart rate trends in general.
12. The exercise bike does not have a free wheel; the pedals will continue to move until the flywheel stops. Reduce your pedaling speed in a controlled way.
13. Always keep your back straight while using the exercise bike; do not arch your back.
14. Over exercising may result in serious injury or death. If you feel faint or if you experience pain while exercising, stop immediately and cool down.

BEFORE YOU BEGIN

Thank you for selecting the new WESLO® PURSUIT CT 3.8 R exercise bike. Cycling is an effective exercise for increasing cardiovascular fitness, building endurance, and toning the body. The PURSUIT CT 3.8 R exercise bike provides a selection of features designed to make your workouts at home more effective and enjoyable.

For your benefit, read this manual carefully before you use the exercise bike. If you have questions

after reading this manual, please see the back cover of this manual. To help us assist you, note the product model number and serial number before contacting us. The model number and the location of the serial number decal are shown on the front cover of this manual.

Before reading further, please review the drawing below and familiarize yourself with the labeled parts.

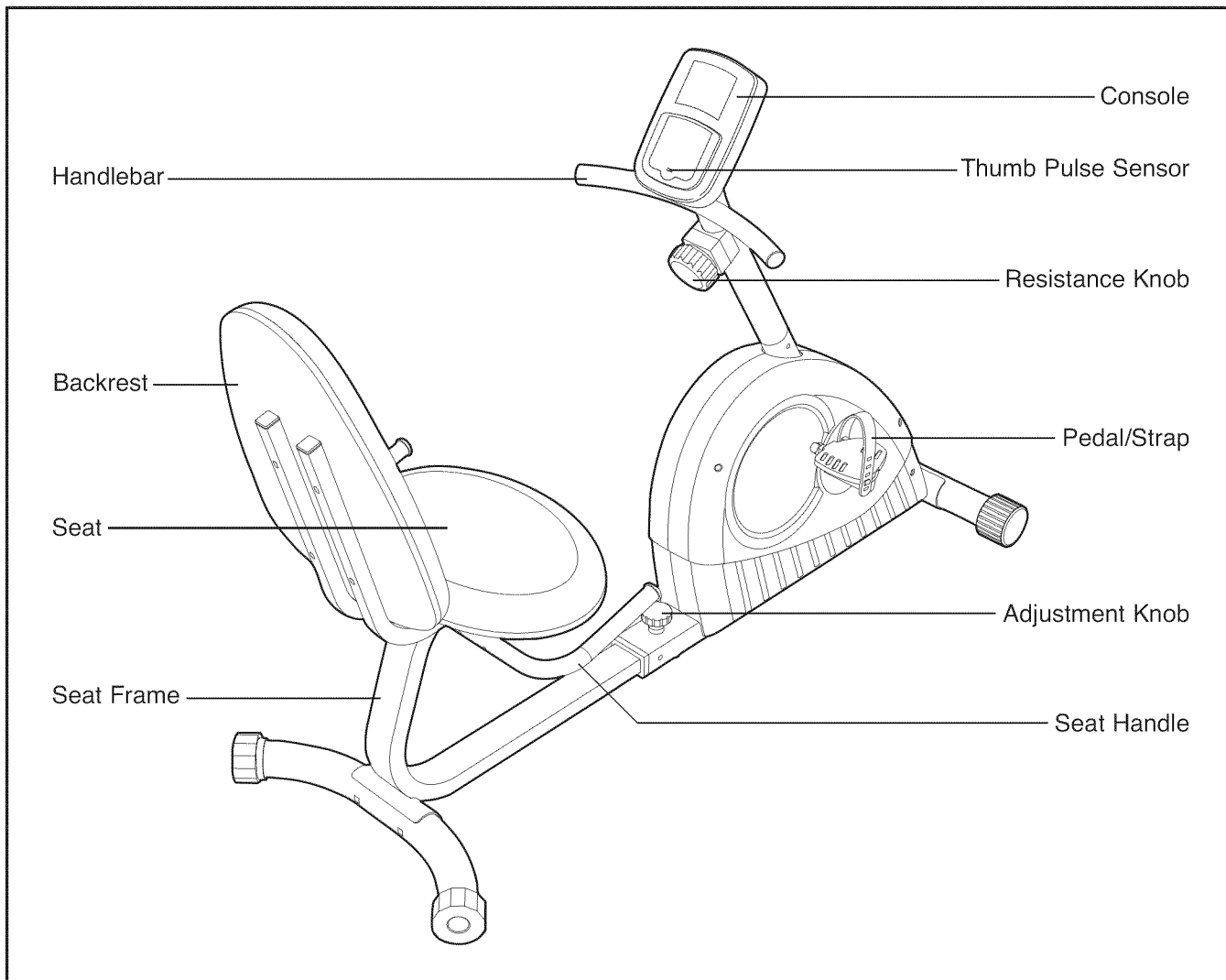

ASSEMBLY

Assembly requires two persons. Place all parts of the exercise bike in a cleared area and remove the packing materials. Do not dispose of the packing materials until assembly is completed.

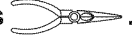
In addition to the included tool(s), assembly requires a Phillips screwdriver , two adjustable wrenches , and pliers .

See the drawings below to identify the small parts needed for assembly. The number in parentheses below each drawing is the key number of the part, from the PART LIST near the end of this manual. The number following the key number is the quantity needed for assembly. **Note: If a part is not in the hardware kit, check to see if it has been preassembled. To avoid damaging parts, do not use power tools for assembly. If a part is missing, call 1-866-699-3756.**

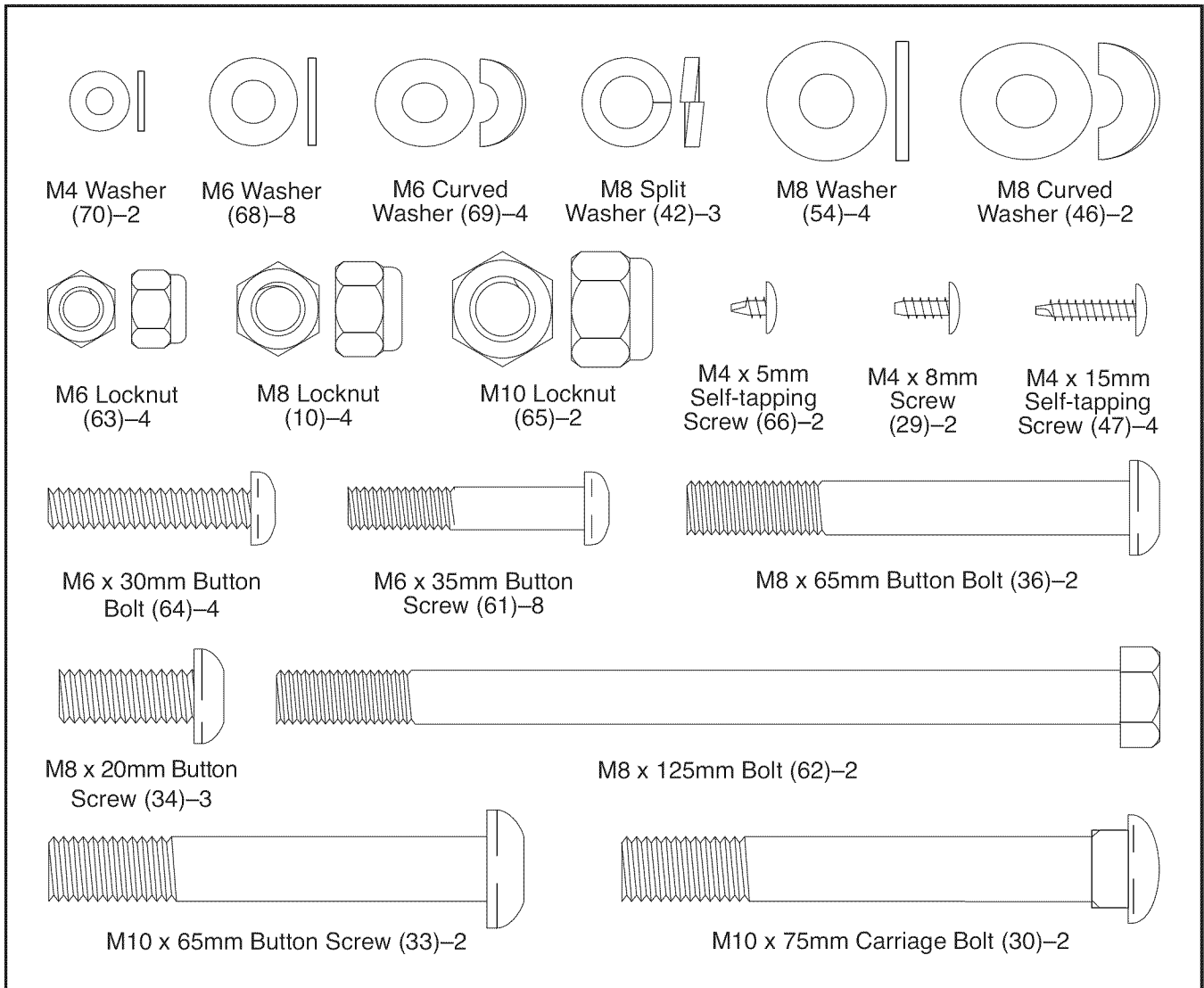

1.

To make assembly easier, read the information on page 5 before you begin.

Turn the Front Stabilizer (2) so that the large holes are facing the Frame (1). Attach the Front Stabilizer to the Frame with two M10 x 65mm Button Screws (33).

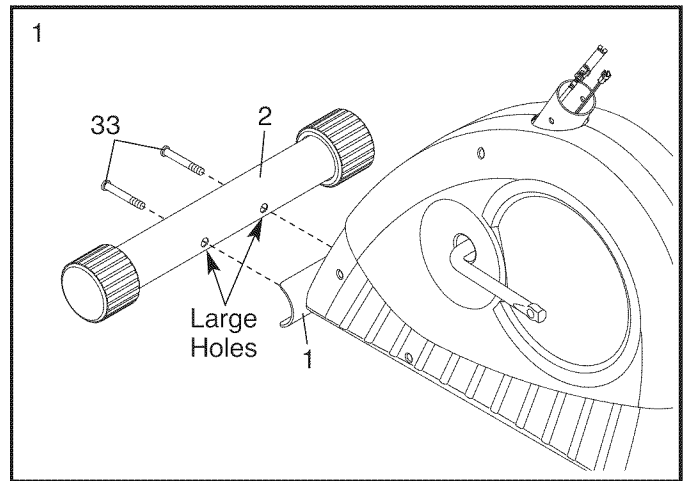

2. Attach the Rear Stabilizer (6) to the Seat Frame (5) with two M10 x 75mm Carriage Bolts (30) and two M10 Locknuts (65).

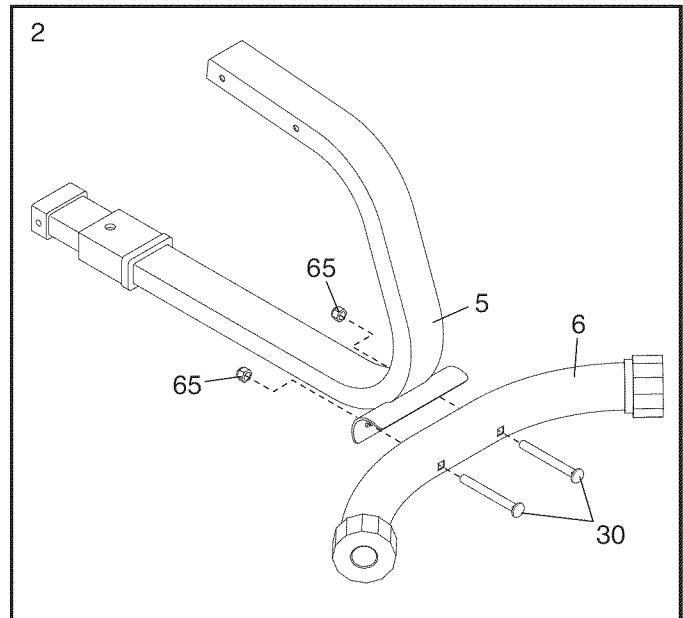

3. Insert the end of the Seat Frame (5) into the Frame (1).

Firmly press the Frame Bushing (56) into the Frame (1).

Attach the Frame Bushing (56) to the Frame (1) with two M4 x 5mm Self-tapping Screws (66).

Tighten the Adjustment Knob (9) into the Frame (1). Carefully tip the exercise bike onto its side.

Attach the two Bumpers (57) to the Frame (1) with two M4 x 8mm Screws (29) and two M4 Washers (70). Then, tip the exercise bike upright.

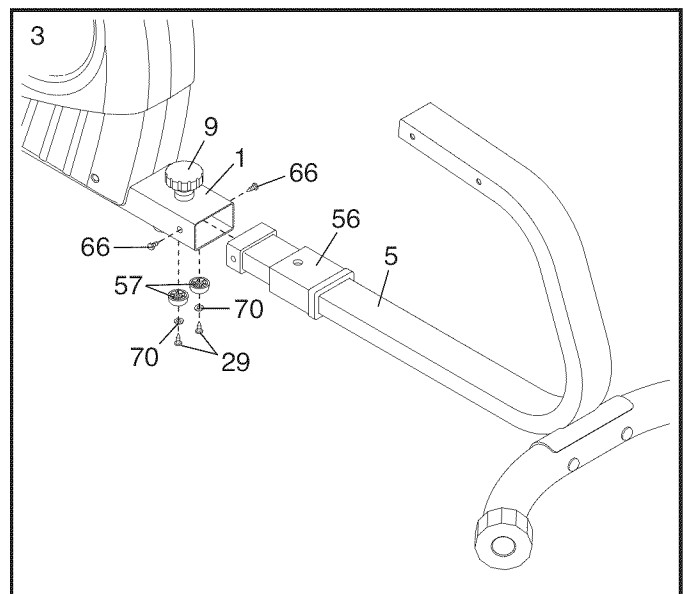

4. Attach the Left and Right Seat Brackets (14, 15) to the Seat Frame (5) with two M8 x 125mm Bolts (62), four M8 Washers (54), and two M8 Locknuts (10) as shown. **Do not tighten the Locknuts yet.**

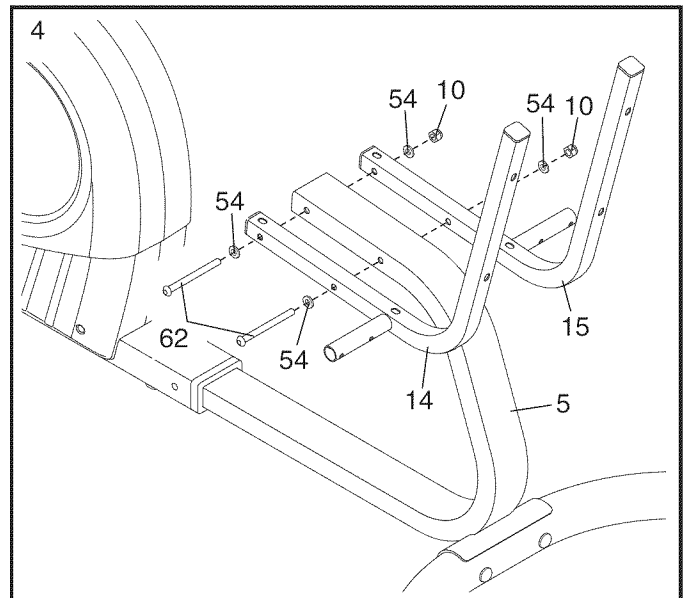

5. Attach a Seat Handle (59) to the round tube on the Left Seat Bracket (14) with two M6 x 30mm Button Bolts (64), two M6 Curved Washers (69), and two M6 Locknuts (63).

Attach the other Seat Handle (59) to the Right Seat Bracket (15) in the same way.

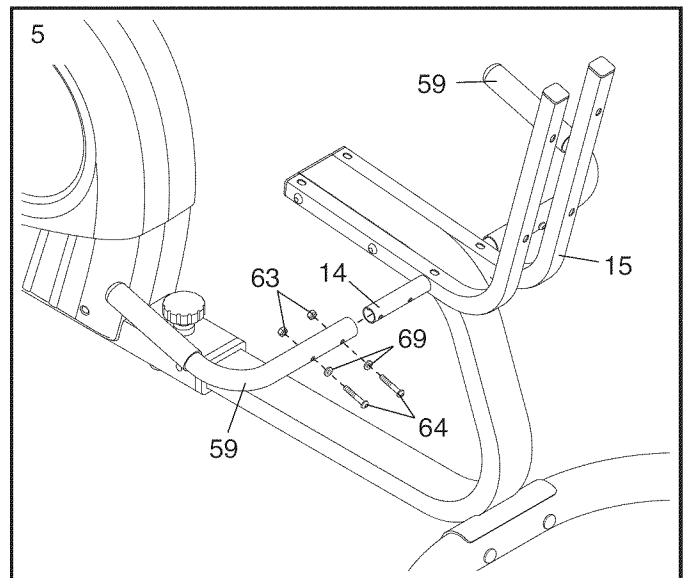

6. Attach the Backrest (60) to the Seat Brackets (14, 15) with four M6 x 35mm Button Screws (61) and four M6 Washers (68).

See step 4. Tighten the two M8 Locknuts (10).

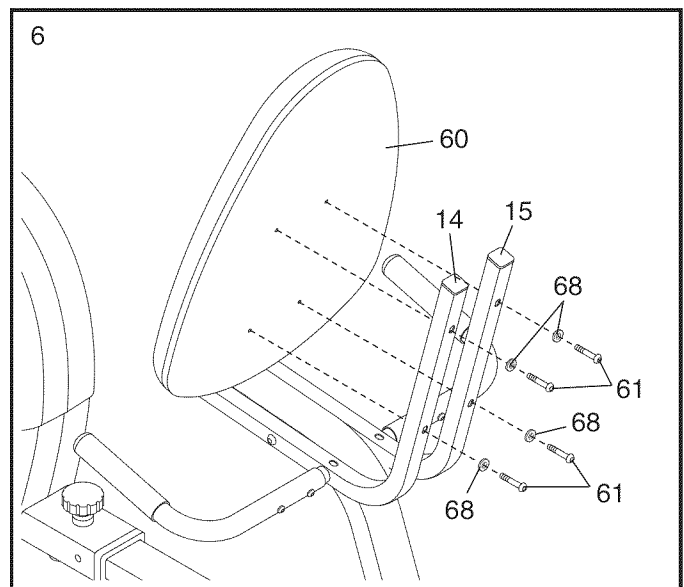

7. Attach the Seat (12) to the Seat Brackets (14, 15) with four M6 x 35mm Button Screws (61) and four M6 Washers (68).

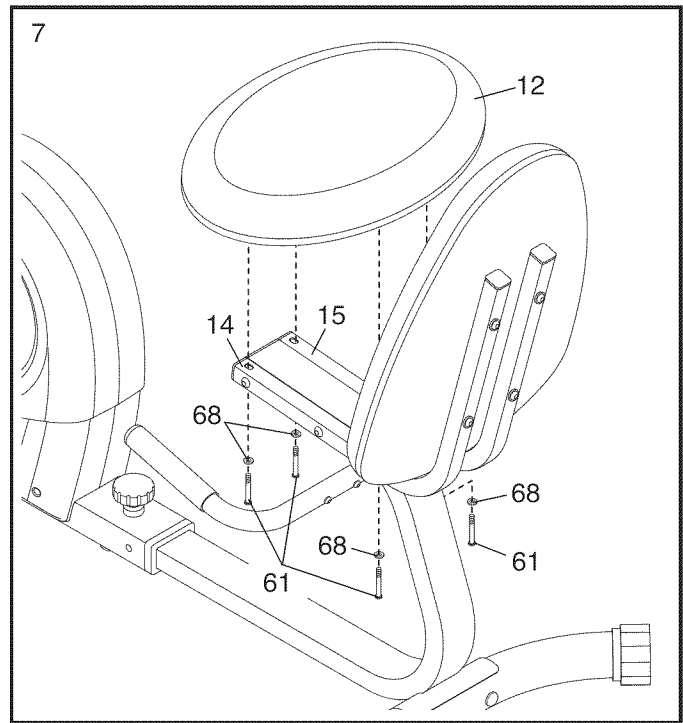

8. While another person holds the Upright (13) in the position shown, connect the Extension Wire (52) to the Reed Switch Wire (43).

Connect the Resistance Cable (19) to the Lower Cable (45) in the following way:

- **See drawing A.** Pull upward on the metal bracket on the Lower Cable (45), and insert the tip of the Resistance Cable (19) into the wire clip inside the metal bracket as shown.
- **See drawing B.** Firmly pull the Resistance Cable (19) upward and slide it into the top of the metal bracket as shown.
- **See drawing C.** Using pliers, squeeze the prongs on the upper end of the metal bracket together.

Push the excess wire and cable downward into the Frame (1), and insert the Upright (13) into the Frame.

Tip: Avoid pinching the wires and cables. Attach the Upright (13) to the Frame (1) with three M8 x 20mm Button Screws (34) and three M8 Split Washers (42).

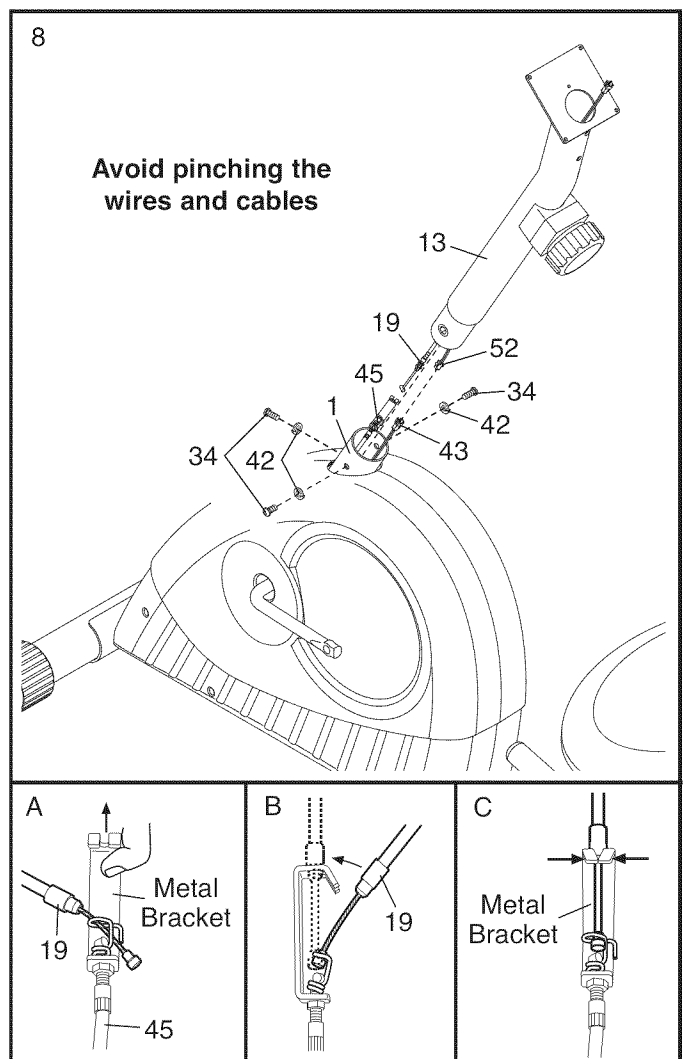

9. Attach the Handlebar (53) to the Upright (13) with two M8 x 65mm Button Bolts (36), two M8 Curved Washers (46), and two M8 Locknuts (10).

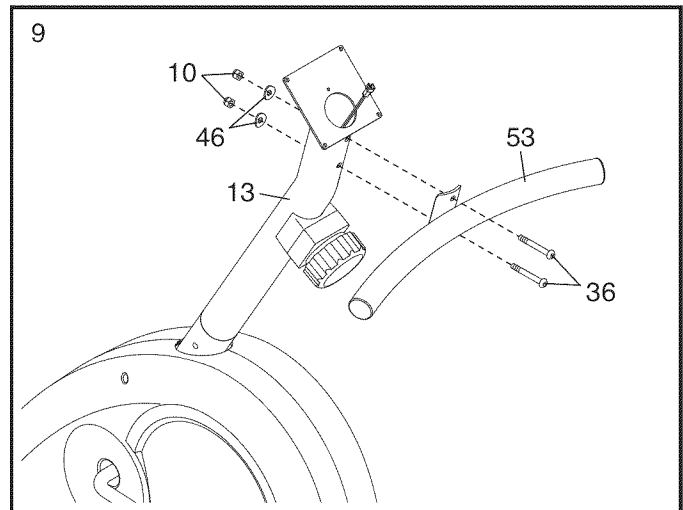

10. The Console (16) requires four AA batteries (not included); alkaline batteries are recommended. **IMPORTANT: If the Console has been exposed to cold temperatures, allow it to warm to room temperature before inserting batteries. Otherwise, you may damage the console displays or other electronic components.** Remove the screw, remove the battery cover, and insert the batteries into the battery compartment. **Make sure to orient the batteries as shown by the diagram inside the battery compartment.** Then, reattach the battery cover.

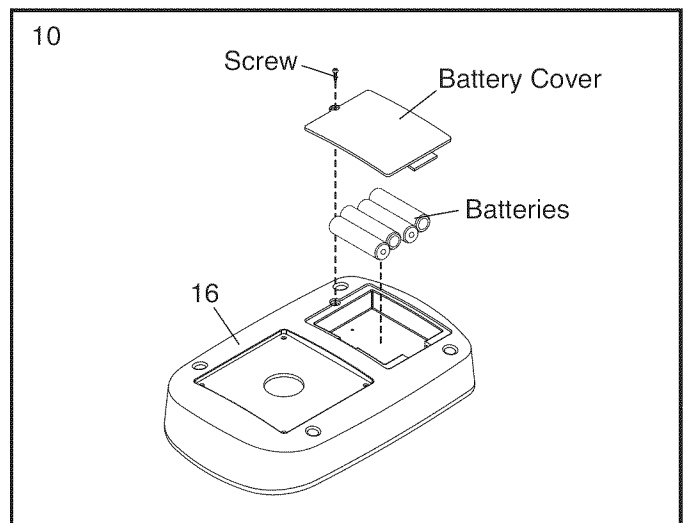

11. While another person holds the Console (16) near the Upright (13), connect the console wire to the Extension Wire (52).

Insert the wires downward into the Upright (13).

Tip: Avoid pinching the wires. Attach the Console (16) to the Upright (13) with four M4 x 15mm Self-tapping Screws (47).

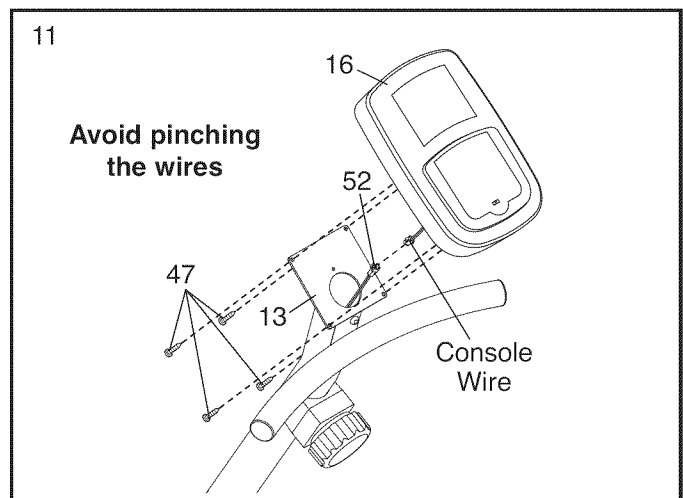

12. Identify the Left Pedal (24), which is marked with an "L" sticker.

Using an adjustable wrench, **firmly tighten** the Left Pedal (24) **counterclockwise** into the left arm of the Crank (21).

Tighten the Right Pedal (not shown) **clockwise** into the right arm of the Crank (not shown).

Adjust the strap on the Left Pedal (24) to the desired position, and press the end of the strap onto the tab on the Left Pedal (24). Adjust the strap on the Right Pedal (not shown) in the same way.

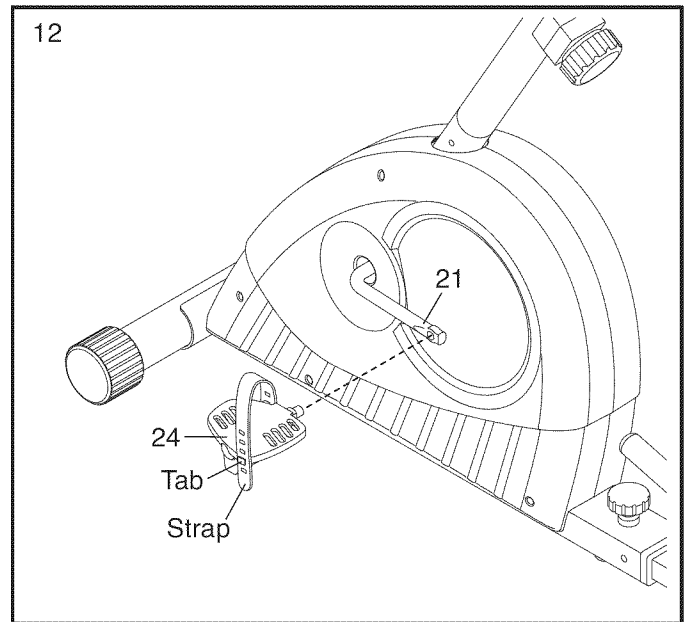

13. **Make sure that all parts are properly tightened before you use the exercise bike.** After assembly is completed, some extra parts may be left over. Place a mat under the exercise bike to protect the floor.

HOW TO USE THE EXERCISE BIKE

HOW TO ADJUST THE SEAT FRAME

For effective exercise, the seat should be in the proper position. As you pedal, there should be a slight bend in your knees when the pedals are in the most forward position.

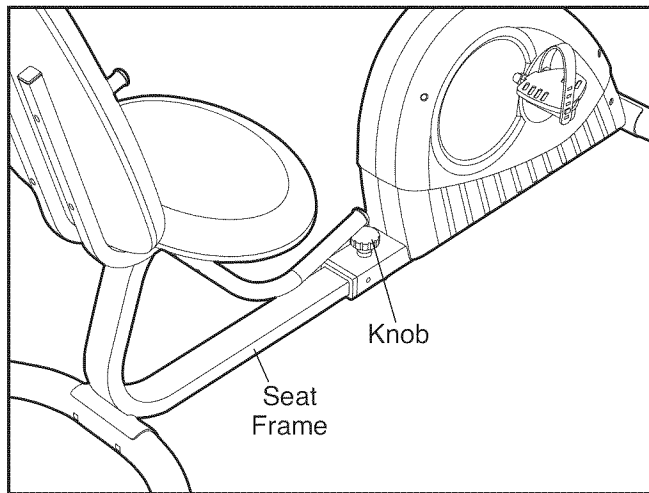

To adjust the seat frame, first loosen the adjustment knob on the frame. Slide the seat frame forward or backward to the desired position. Then, retighten the adjustment knob.

HOW TO ADJUST THE PEDALING RESISTANCE

To increase the resistance of the pedals, turn the resistance knob clockwise; to decrease the resistance, turn the knob counterclockwise.

IMPORTANT: Stop turning the knob when turning becomes difficult, or damage may result.

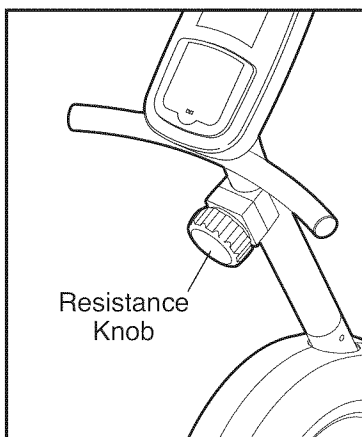

FEATURES OF THE CONSOLE

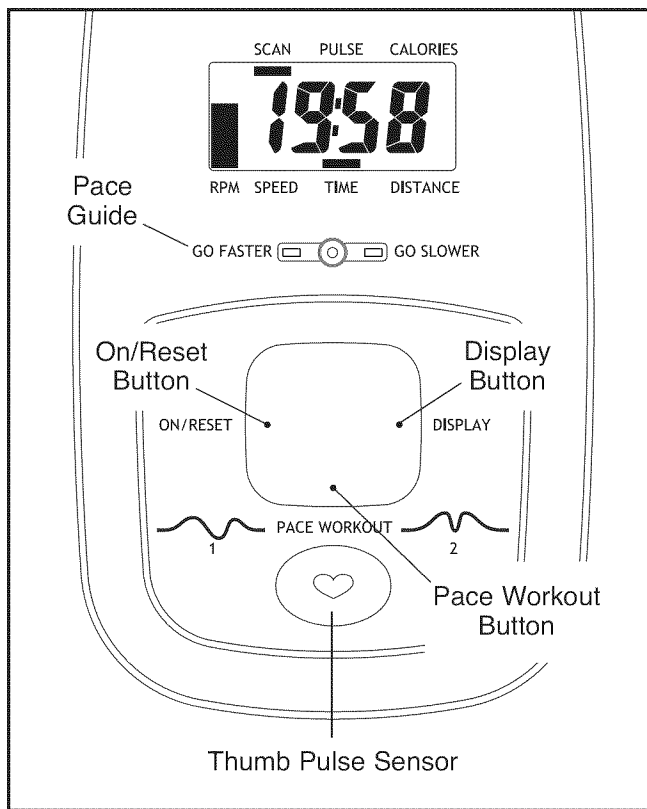

The console offers a selection of features designed to make your workouts more effective. As you pedal, the console will provide continuous exercise feedback. You can even measure your heart rate using the built-in thumb pulse sensor.

The console also offers two pace workouts that prompt you to vary your pedaling pace while guiding you through an effective workout.

To use the manual mode, see page 12. To use a pace workout, see page 13.

Before using the console, make sure that batteries are installed (see assembly step 10 on page 9). If there is a sheet of clear plastic on the display, remove the plastic.

HOW TO USE THE MANUAL MODE

1. Turn on the console.

To turn on the console, press the On/Reset button or begin pedaling. The entire display and the pace guide will light for a moment; the console will then be ready for use.

2. Select the manual mode.

When you turn on the console, the manual mode will be selected. If you have selected a pace workout, reselect the manual mode by pressing the Pace Workout button repeatedly until zeros appear in the display.

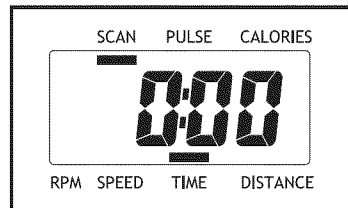

3. Follow your progress with the display.

The display can show the following workout information:

RPM—The RPM meter on the left side of the display indicates your approximate pedaling pace (revolutions per minute).

Speed—This mode shows your pedaling speed, in miles per hour (mph) or kilometers per hour (km/h).

Time—This mode shows the elapsed time. Note: When a pace workout is selected, the display shows the time remaining in the workout instead of the elapsed time.

Distance—This mode shows the distance you have pedaled, in miles or kilometers.

Calories—This mode shows the approximate number of calories you have burned.

Pulse—This mode shows your heart rate when you use the thumb pulse sensor.

Scan—This mode shows the speed, time, distance, calories, and pulse modes, for a few seconds each, in a repeating cycle. Note: The pulse mode will appear only when you are using the pulse sensor.

When you turn on the console, the scan mode will be selected automatically. One indicator will appear below the word Scan to show that the scan mode is selected, and a second indicator will show which information is currently displayed. Note: If you have selected a different mode, press the Display button repeatedly to reselect the Scan mode.

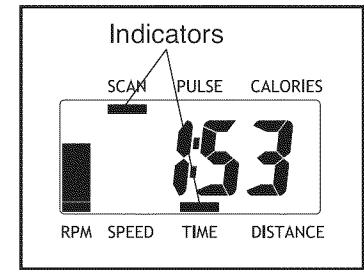

To select the speed, time, distance, or calories mode for continuous display, press the Display button repeatedly.

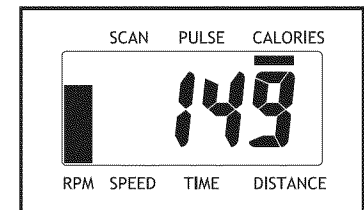

The indicators will show which mode is selected. Make sure there is not an indicator below the word Scan.

Note: The console can show speed and distance in either miles or kilometers. The letters “mph” or “km/h” will appear in the display to show which unit of measurement is selected.

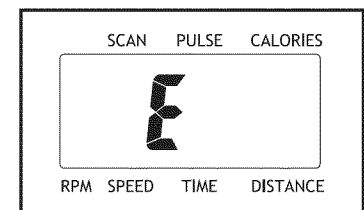

To change the unit of measurement, first hold down the On/Reset button for a few seconds. An “E” (for English) or an “M” (for metric) will appear in the display. Press the Display button to change the unit of measurement. Note: When the batteries are replaced, it may be necessary to reselect the desired unit of measurement.

To reset the display, press the On/Reset button.

To pause the console, stop pedaling. If the time is displayed, it will flash. To continue your workout, simply resume pedaling.

4. Measure your heart rate if desired.

To measure your heart rate, **stop pedaling** and place your thumb on the pulse sensor. **Do not press too hard, or the circula-**

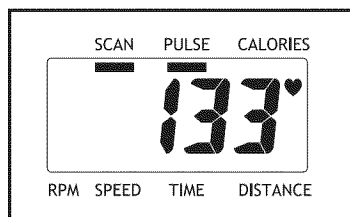

tion in your thumb will be restricted and your pulse will not be detected. After a few seconds, the heart-shaped indicator in the display will flash **steadily**, two dashes will appear, and then your heart rate will be shown. Hold your thumb on the pulse sensor for about 15 seconds for the most accurate reading.

If the displayed heart rate appears to be too high or too low, or if your heart rate is not displayed, lift your thumb off the pulse sensor for a few seconds. Then, place your thumb on the pulse sensor as described above.

Make sure you are applying the proper amount of pressure to the pulse sensor. Try the pulse sensor several times until you become familiar with it. Remember to stand still while measuring your heart rate.

5. When you are finished exercising, the console will turn off automatically.

If the pedals do not move for a few seconds, the console will pause. If the pedals do not move for a few minutes, the console will turn off and the display will be reset.

HOW TO USE A PACE WORKOUT

1. Turn on the console.

See step 1 on page 12.

2. Select a pace workout.

To select a pace workout, press the Pace Workout button repeatedly until P1 or P2 appears in the display. A few

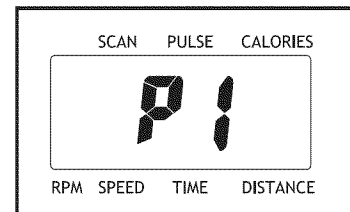

seconds after you select a pace workout, the display will show the duration of the workout.

3. Begin pedaling to start the workout.

Each pace workout consists of 30 one-minute segments. One target pace is programmed for each segment. Any time the target pace is about to change, the display will flash for a few seconds to alert you.

During the workout, the pace guide will prompt you to keep your pedaling pace near the target

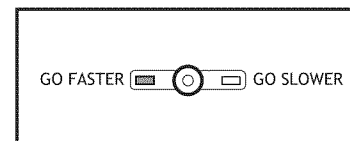

pace setting for the current segment. When the left indicator lights, increase your pace; when the right indicator lights, decrease your pace. When the center indicator lights, maintain your current pace.

IMPORTANT: The pace guide is intended only to provide a goal. Make sure to pedal at a pace that is comfortable for you.

The display can show the time remaining in the workout. If you stop pedaling for a few seconds, the workout will pause and the time will flash if it is displayed. To restart the workout, simply resume pedaling.

4. Follow your progress with the display.

See step 3 on page 12.

5. Measure your heart rate if desired.

See step 4 at the left.

6. When you are finished exercising, the console will turn off automatically.

See step 5 at the left.

MAINTENANCE AND TROUBLESHOOTING

Inspect and tighten all parts of the exercise bike regularly. Replace any worn parts immediately.

To clean the exercise bike, use a damp cloth and a small amount of mild detergent. **IMPORTANT: To avoid damage to the console, keep liquids away from the console and keep the console out of direct sunlight.**

BATTERY REPLACEMENT

If the console display becomes dim, replace all the batteries at the same time; most console problems are the result of low batteries. To replace the batteries, see assembly step 10 on page 9.

HOW TO ADJUST THE REED SWITCH

If the console does not display correct feedback, the reed switch should be adjusted. To adjust the reed switch, you must first remove the left pedal and the left shield. Using an adjustable wrench, turn the left pedal clockwise and remove it. Next, remove all the screws from the left and right shields; **there are two sizes of screws in the shields—note which size of screw you remove from each hole.** Then, gently pull the left shield away from the frame.

Locate the Reed Switch (43). Turn the Crank (21) until the Magnet (38) is aligned with the Reed Switch. Loosen, but do not remove, the M4 x 15mm Self-tapping Screw (47). Slide the Reed Switch slightly closer to or away from the Magnet, and then retighten the Screw. Turn the Crank for a moment. Repeat until the console displays correct feedback. When the Reed Switch is correctly adjusted, reattach the left shield and the left pedal.

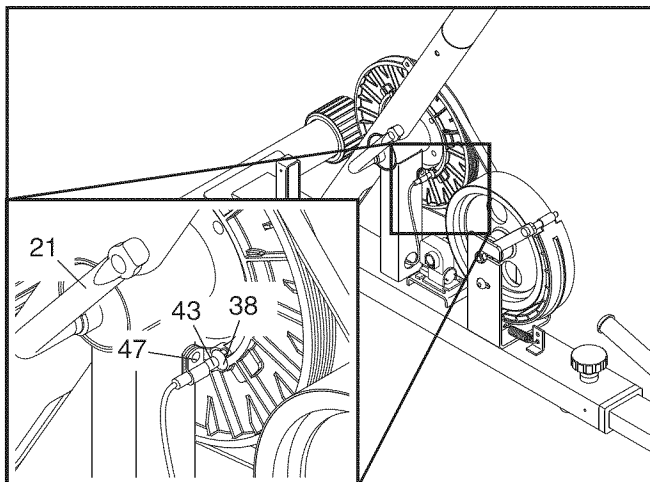

HOW TO ADJUST THE DRIVE BELT

If you can feel the pedals slip while you are pedaling, even when the resistance is at the highest level, the drive belt may need to be adjusted.

To adjust the drive belt, you must first remove the right pedal and the right shield. Using an adjustable wrench, turn the right pedal counterclockwise and remove it. Next, remove all the screws from the left and right shields; **there are two sizes of screws in the shields—note which size of screw you remove from each hole.** Then, gently pull the right shield away from the frame.

Loosen the Flywheel Axle (39). Next, tighten the M6 Locknuts (63), one on each side of the Flywheel (37), until the Drive Belt (35) is tight. Then, tighten the Flywheel Axle and reattach the right shield and the right pedal.

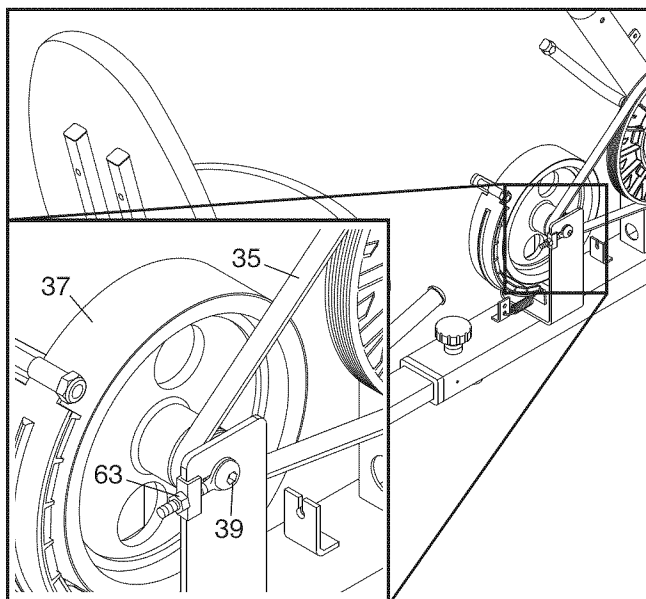

FCC INFORMATION

This equipment has been tested and found to comply with the limits for a Class B digital device, pursuant to part 15 of the FCC Rules. These limits are designed to provide reasonable protection against harmful interference in a residential installation. This equipment generates, uses, and can radiate radio frequency energy and, if not installed and used in accordance with the instructions, may cause harmful interference to radio communications. However, there is no guarantee that interference will not occur in a particular installation. If this equipment does cause harmful interference to radio or television reception, which can be determined by turning the equipment off and on, the user is encouraged to try to correct the interference by one or more of the following measures:

- Reorient or relocate the receiving antenna.
- Increase the separation between the equipment and the receiver.
- Connect the equipment into an outlet on a circuit different from that to which the receiver is connected.
- Consult the dealer or an experienced radio/TV technician for help.

WARNING: Per FCC rules, changes or modifications not expressly approved by ICON could void the user's authority to operate the equipment.

EXERCISE GUIDELINES

⚠ WARNING: Before beginning this or any exercise program, consult your physician. This is especially important for persons over the age of 35 or persons with pre-existing health problems.

The pulse sensor is not a medical device. Various factors may affect the accuracy of heart rate readings. The pulse sensor is intended only as an exercise aid in determining heart rate trends in general.

These guidelines will help you to plan your exercise program. For detailed exercise information, obtain a reputable book or consult your physician. Remember, proper nutrition and adequate rest are essential for successful results.

EXERCISE INTENSITY

Whether your goal is to burn fat or to strengthen your cardiovascular system, exercising at the proper intensity is the key to achieving results. You can use your heart rate as a guide to find the proper intensity level. The chart below shows recommended heart rates for fat burning and aerobic exercise.

165	155	145	140	130	125	115	♥♥
145	138	130	125	118	110	103	♥
125	120	115	110	105	95	90	♥
<hr/>							
20	30	40	50	60	70	80	

To find the proper intensity level, find your age at the bottom of the chart (ages are rounded off to the nearest ten years). The three numbers listed above your age define your “training zone.” The lowest number is the heart rate for fat burning, the middle number is the heart rate for maximum fat burning, and the highest number is the heart rate for aerobic exercise.

Burning Fat—To burn fat effectively, you must exercise at a low intensity level for a sustained period of time. During the first few minutes of exercise, your body uses *carbohydrate calories* for energy. Only after the first few minutes of exercise does your body begin to use stored *fat calories* for energy. If your goal is to burn fat, adjust the intensity of your exercise until your heart rate is near the lowest number in your training zone. For maximum fat burning, exercise with your heart rate near the middle number in your training zone.

Aerobic Exercise—If your goal is to strengthen your cardiovascular system, you must perform aerobic exercise, which is activity that requires large amounts of oxygen for prolonged periods of time. For aerobic exercise, adjust the intensity of your exercise until your heart rate is near the highest number in your training zone.

WORKOUT GUIDELINES

Warming Up—Start with 5 to 10 minutes of stretching and light exercise. A warm-up increases your body temperature, heart rate, and circulation in preparation for exercise.

Training Zone Exercise—Exercise for 20 to 30 minutes with your heart rate in your training zone. (During the first few weeks of your exercise program, do not keep your heart rate in your training zone for longer than 20 minutes.) Breathe regularly and deeply as you exercise—never hold your breath.

Cooling Down—Finish with 5 to 10 minutes of stretching. Stretching increases the flexibility of your muscles and helps to prevent post-exercise problems.

EXERCISE FREQUENCY

To maintain or improve your condition, complete three workouts each week, with at least one day of rest between workouts. After a few months of regular exercise, you may complete up to five workouts each week, if desired. Remember, the key to success is to make exercise a regular and enjoyable part of your everyday life.

SUGGESTED STRETCHES

The correct form for several basic stretches is shown at the right. Move slowly as you stretch—never bounce.

1. Toe Touch Stretch

Stand with your knees bent slightly and slowly bend forward from your hips. Allow your back and shoulders to relax as you reach down toward your toes as far as possible. Hold for 15 counts, then relax. Repeat 3 times. Stretches: Hamstrings, back of knees and back.

2. Hamstring Stretch

Sit with one leg extended. Bring the sole of the opposite foot toward you and rest it against the inner thigh of your extended leg. Reach toward your toes as far as possible. Hold for 15 counts, then relax. Repeat 3 times for each leg. Stretches: Hamstrings, lower back and groin.

3. Calf/Achilles Stretch

With one leg in front of the other, reach forward and place your hands against a wall. Keep your back leg straight and your back foot flat on the floor. Bend your front leg, lean forward and move your hips toward the wall. Hold for 15 counts, then relax. Repeat 3 times for each leg. To cause further stretching of the achilles tendons, bend your back leg as well. Stretches: Calves, achilles tendons and ankles.

4. Quadriceps Stretch

With one hand against a wall for balance, reach back and grasp one foot with your other hand. Bring your heel as close to your buttocks as possible. Hold for 15 counts, then relax. Repeat 3 times for each leg. Stretches: Quadriceps and hip muscles.

5. Inner Thigh Stretch

Sit with the soles of your feet together and your knees outward. Pull your feet toward your groin area as far as possible. Hold for 15 counts, then relax. Repeat 3 times. Stretches: Quadriceps and hip muscles.

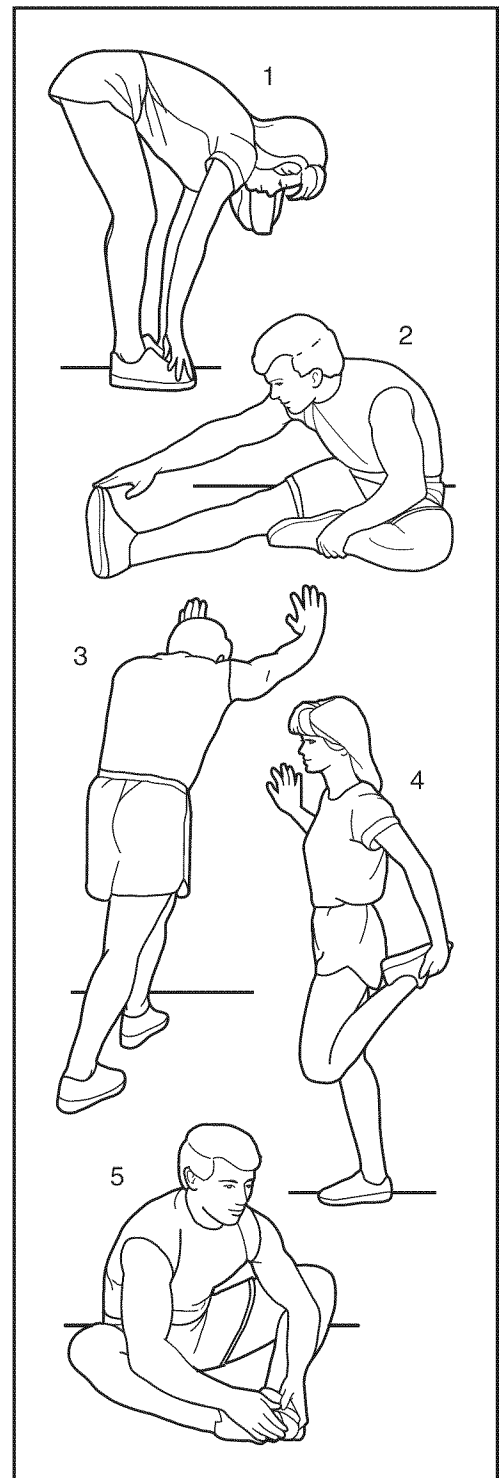

PART LIST—Model No. 831.21811.1

R1010A

Key No.	Qty.	Description	Key No.	Qty.	Description
1	1	Frame	38	2	Magnet
2	1	Front Stabilizer	39	1	Flywheel Axle
3	2	Handlebar Cap	40	2	M10 Small Washer
4	2	Front Stabilizer Cap	41	5	M4 x 25mm Screw
5	1	Seat Frame	42	3	M8 Split Washer
6	1	Rear Stabilizer	43	1	Reed Switch/Wire
7	2	Seat Handle Cap	44	1	Crank Bearing Set
8	2	Rear Stabilizer Cap	45	1	Lower Cable
9	1	Adjustment Knob	46	2	M8 Curved Washer
10	7	M8 Locknut	47	9	M4 x 15mm Self-tapping Screw
11	1	C-magnet	48	1	Spring
12	1	Seat	49	1	Bracket
13	1	Upright	50	2	Foam Grip
14	1	Left Seat Bracket	51	1	M6 x 45mm Bolt
15	1	Right Seat Bracket	52	1	Extension Wire
16	1	Console	53	1	Handlebar
17	1	Left Shield	54	4	M8 Washer
18	1	Right Shield	55	1	M5 x 40mm Screw
19	1	Resistance Control/Cable	56	1	Frame Bushing
20	1	Seat Frame Bushing	57	2	Bumper
21	1	Crank/Pulley	58	4	Square Cap
22	1	Reed Switch Clamp	59	2	Seat Handle
23	1	M8 x 20mm Bolt	60	1	Backrest
24	1	Left Pedal/Strap	61	8	M6 x 35mm Button Screw
25	2	6000Z Bearing	62	2	M8 x 125mm Bolt
26	1	Right Pedal/Strap	63	6	M6 Locknut
27	1	Resistance Knob	64	4	M6 x 30mm Button Bolt
28	2	U-bracket	65	2	M10 Locknut
29	2	M4 x 8mm Screw	66	2	M4 x 5mm Self-tapping Screw
30	2	M10 x 75mm Carriage Bolt	67	1	M5 Curved Washer
31	2	Eyebolt	68	8	M6 Washer
32	1	M6 Nut	69	4	M6 Curved Washer
33	2	M10 x 65mm Button Screw	70	2	M4 Washer
34	3	M8 x 20mm Button Screw	71	1	Seat Frame Cap
35	1	Drive Belt	*	—	User's Manual
36	2	M8 x 65mm Button Bolt	*	—	Assembly Tool
37	1	Flywheel			

Note: Specifications are subject to change without notice. For information about ordering replacement parts, see the back cover of this manual. **If a part is missing, call 1-866-699-3756.** *These parts are not illustrated.

EXPLODED DRAWING—Model No. 831.21811.1

R1010A

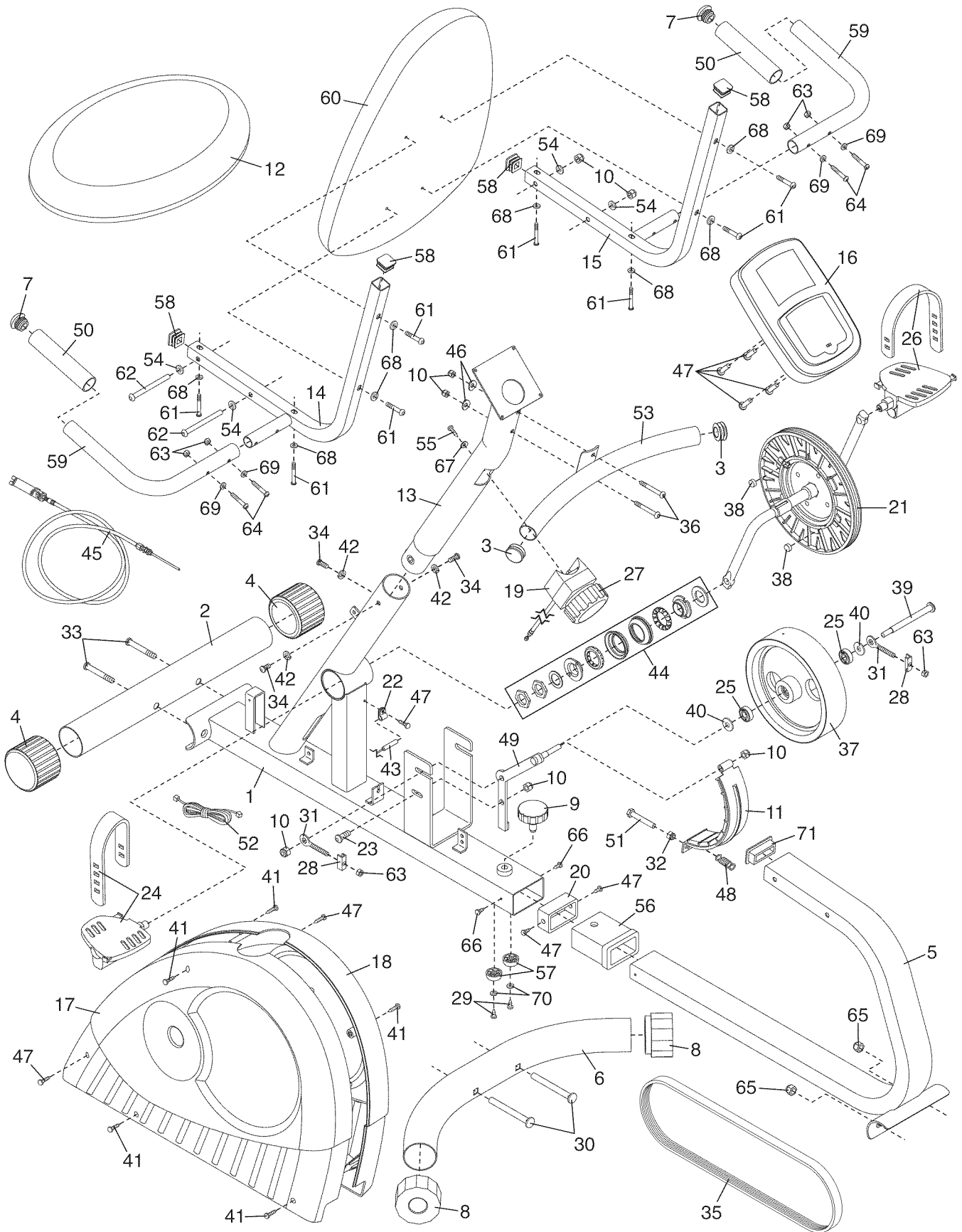

Get it fixed, at your home or ours!

Your Home

For repair—**in your home**—of **all** major brand appliances, lawn and garden equipment, or heating and cooling systems, **no matter who made it, no matter who sold it!**

For the replacement parts, accessories, and user's manuals that you need to do-it-yourself.

For Sears professional installation of home appliances and items like garage door openers and water heaters.

1-800-4-MY-HOME® (1-800-469-4663)

Call anytime, day or night (U.S.A. and Canada)

www.sears.com

www.sears.ca

Our Home

For repair of carry-in items like vacuums, lawn equipment, and electronics, call or go on-line for the location of your nearest **Sears Parts & Repair Center.**

1-800-488-1222 Call anytime, day or night (U.S.A. only)

www.sears.com

To purchase a protection agreement (U.S.A.) or maintenance agreement (Canada) on a product serviced by Sears:

1-800-827-6655 (U.S.A.)

1-800-361-6665 (Canada)

Para pedir servicio de reparación a domicilio, y para ordenar piezas:

1-888-SU-HOGAR® (1-888-784-6427)



® Registered Trademark / ™ Trademark / ™ Service Mark of Sears Brands, LLC
® Marca Registrada / ™ Marca de Fábrica / ™ Marca de Servicio de Sears Brands, LLC

90 DAY FULL WARRANTY

If this Bike Exerciser fails due to a defect in material or workmanship within 90 days of the date of purchase, call 1-800-4-MY-HOME® (1-800-469-4663) to arrange for free repair (or replacement if repair proves impossible).

This warranty does not apply when the Bike Exerciser is used commercially or for rental purposes.

This warranty gives you specific legal rights, and you may also have other rights which vary from state to state.

Sears, Roebuck and Co., Hoffman Estates, IL 60179