

Use & Care Guide

Model: 415.16135110

Kenmore[®]

Liquid Propane Gas Grill

P/N G524-001-010801
Sears Brands Management Corporation
Hoffman Estates, IL 60179 U.S.A.
www.kenmore.com
www.sears.com



 **DANGER** 

If you smell gas:

1. Shut off gas to the appliance.
2. Extinguish any open flame.
3. Open lid.
4. If odor continues, keep away from the appliance and immediately call your gas supplier or your fire department.

 **WARNING** 

1. Do not store or use gasoline or other flammable liquids or vapors in the vicinity of this or any other appliance.
2. An LP Tank not connected for use shall not be stored in the vicinity of this or any other appliance.

Call the Grill Information Center for Help and Parts
Missing Parts? Assembly Questions? Operation Problems?
Before returning grill to store, call **1-800-241-7548**

Product Record

IMPORTANT: Fill out the product record information below.

Model Number _____

Serial Number _____
See rating label on grill for serial number.

Date Purchased _____

To Installer/Assembler: Leave these instructions with consumer.

To Consumer: Keep this manual for future reference.

 **CAUTION** 

Some parts may contain sharp edges, especially as noted in these instructions.
Wear protective gloves if necessary.

 **CAUTION** 

For residential use only. Do not use for commercial cooking.

 **WARNING** 

CALIFORNIA PROPOSITION 65

1. Combustion by-products produced when using this product contain chemicals known to the State of California to cause cancer, birth defects, and other reproductive harm.
2. This product contains chemicals, including lead and lead compounds, known to the State of California to cause cancer, birth defects or other reproductive harm.

Wash your hands after handling this product.

Installation Safety Precautions

- Use grill, as purchased, only with LP (propane) gas and the regulator/valve assembly supplied.
- Grill installation must conform with local codes, or in the absence of local codes, with either the National Fuel Gas Code, ANSI Z223.1/ NFPA 54, Natural Gas and Propane Installation Code, CSA B149.1, or Propane Storage and Handling Code, B149.2, or the Standard for Recreational Vehicles, ANSI A 119.2/NFPA 1192, and CSA Z240 RV Series, Recreational Vehicle Code, as applicable.
- All electrical accessories (such as a rotisserie) must be electrically grounded in accordance with local codes, or National Electrical Code, ANSI / NFPA 70 or Canadian Electrical Code, CSA C22.1. Keep any electrical cords and/or fuel supply hoses away from any hot surfaces.
- Grill is not for use in or on recreational vehicles and/or boats.
- This grill is safety certified for use in the United States and/or Canada only. Do not modify for use in any other location. Modification will result in a safety hazard.

Safety Symbols

The symbols and boxes shown below explain what each heading means. Read and follow all of the messages found throughout the manual.

 **DANGER** 

DANGER: Indicates an imminently hazardous situation which, if not avoided, will result in death or serious injury.

 **WARNING** 

WARNING: Be alert to the possibility of serious bodily injury if the instructions are not followed. Be sure to read and carefully follow all of the messages.

 **CAUTION** 

CAUTION: Indicates a potentially hazardous situation which, if not avoided, may result in minor or moderate injury.

Table of Contents

For Your Safety.....	2
Grill Information Center	2
Product Record Information	2
Safety Symbols.....	2
Installation Safety Precautions.....	2
Kenmore Grill Warranty.....	3
Use and Care	4-10
Parts List	11
Parts Diagram	12
Assembly	13-29
Troubleshooting	30-32

Repair Protection Agreements

Congratulations on making a smart purchase. Your new Kenmore product is designed and manufactured for years of dependable operation. But like all products, it may require repair from time to time. That's when having a Repair Protection Agreement can save you money and aggravation.

Here's what the Repair Protection Agreement* includes:

- ✓ **Expert service** by our 10,000 professional repair specialists
- ✓ **Unlimited service and no charge** for parts and labor on all covered repairs
- ✓ **Product replacement** up to \$1500 if your covered product can't be fixed
- ✓ **Discount of 10%** from regular price of service and related installed parts not covered by the agreement; also, 10% off regular price of preventive maintenance check
- ✓ **Fast help by phone** – we call it Rapid Resolution – phone support from a Sears representative. Think of us as a “talking owner's manual.”

Once you purchase the Repair Protection Agreement, a simple phone call is all that it takes for you to schedule service. You can call anytime day or night, or schedule a service appointment online.

The Repair Protection Agreement is a risk-free purchase. If you cancel for any reason during the product warranty period, we will provide a full refund. Or, a prorated refund anytime after the product warranty period expires. Purchase your Repair Protection Agreement today!

Some limitations and exclusions apply. For prices and additional information in the U.S.A. call 1-800-827-6655.

***Coverage in Canada varies on some items. For full details call Sears Canada at 1-800-361-6665.**

Sears Installation Service

For Sears professional installation of home appliances, garage door openers, water heaters, and other major home items, in the U.S.A. or Canada call **1-800-4-MY-HOME®**.

WARRANTY

KENMORE GRILL WARRANTY

One Year Full Warranty on Kenmore Grill

If this grill fails due to a defect in material or workmanship within one year from the date of purchase, call 1-800-4-MY-HOME® to arrange for free repair (or replacement if repair proves impossible).

Ten-Year Limited Warranty on Burners

For ten years from the date of purchase, any burner that rusts through will be replaced free of charge. After the first year from the date of purchase, you pay for labor if you wish to have it installed.

All warranty coverage excludes ignitor batteries and grill part paint loss, discoloration or surface rusting, which are either expendable parts that can wear out from normal use within the warranty period, or are conditions that can be the result of normal use, accident or improper maintenance.

All warranty coverage is void if this grill is ever used for commercial or rental purposes.

All warranty coverage applies only if this grill is used in the United States.

This warranty gives you specific legal rights, and you may also have other rights which vary from state to state.

Sears Brands Management Corp.
Hoffman Estates, IL 60179



WARNING



- **Read and follow all Safety, Assembly, and Use and Care Instructions in this Guide before assembling and cooking with this grill.**
- **Failure to follow all instructions in this Use and Care Guide may lead to fire or explosion, which could result in property damage, personal injury or death.**

This Grill is for Outdoor Use Only

Tools needed for assembly:

- Adjustable wrench (not provided)
- Screwdriver (not provided)
- 7/16" Combination wrench (not provided)

CONVERSION READY

This grill easily converts from LP liquid propane to NG natural gas. Contact **1-800-4-MY-HOME®** or www.sears.com to purchase a natural gas conversion kit, part number 415.7116572.

Dual Fuel™ is a registered trademark of the W. C. Bradley Company and used, with permission, by Sears Holdings Corporation. All rights reserved.





DANGER



- **NEVER** store a spare LP cylinder under or near the appliance or in an enclosed area.

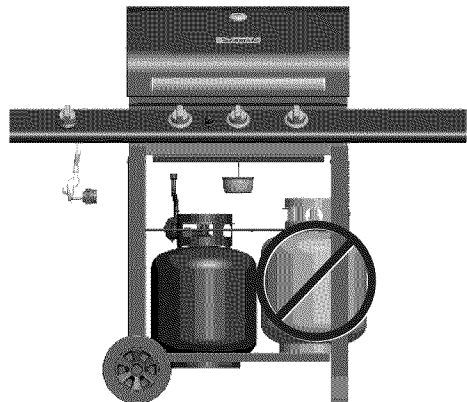

- **Never** fill a cylinder beyond 80% full.
- If the information in the two points above is not followed exactly, a fire causing death or serious injury may occur.
- An overfilled or improperly stored cylinder is a hazard due to possible gas release from the safety relief valve. This could cause an intense fire with risk of property damage, serious injury or death.
- If you see, smell or hear gas escaping, immediately get away from the LP cylinder and appliance and call your fire department.

LP Tank Removal, Transport And Storage

- Turn OFF all control knobs and LP tank valve. Turn coupling nut counterclockwise by hand only - do not use tools to disconnect. Lift LP tank wire upward off of LP tank collar, then lift LP tank up and off of support bracket. Install safety cap onto LP tank valve. Always use cap and strap supplied with valve.

Failure to use safety cap as directed may result in serious personal injury and/or property damage.

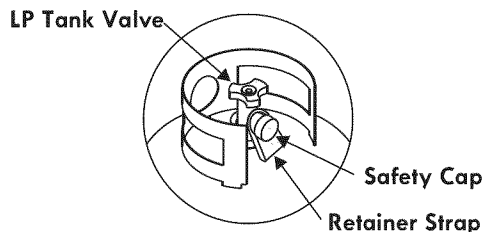

- A disconnected LP tank in storage or being transported must have a safety cap installed (as shown). Do not store an LP tank in enclosed spaces such as a carport, garage, porch, covered patio or other building. Never leave an LP tank inside a vehicle which may become overheated by the sun.
- Do not store an LP tank in an area where children play.

LP Tank

- The LP Tank used with your grill must meet the following requirements:

- Use LP Tanks only with these required measurements: 12" (30.5cm) (diameter) x 18" (45.7 cm) (tall) with 20 lb. (9 kg.) capacity maximum.
- LP Tanks must be constructed and marked in accordance with specifications for LP Tanks of the U.S. Department of Transportation (DOT) or for Canada, CAN/CSA-B339, tanks, spheres and tubes for transportation of dangerous goods. Transport Canada (TC). See LP Tank collar for marking.

- LP Tank valve must have:

- Type 1 outlet compatible with regulator or grill.
- Safety relief valve.
- UL listed Overfill Protection Device (OPD). This OPD safety feature is identified by a unique triangular hand wheel. **Use only LP Tanks equipped with this type of valve.**

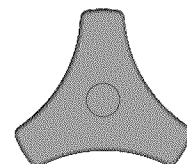

OPD Hand Wheel

- LP Tank must be arranged for vapor withdrawal and include collar to protect LP Tank valve. Always keep LP Tanks in upright position during use, transit or storage.



LP Tank in upright position for vapor withdrawal

LP (Liquefied Petroleum Gas)

- LP gas is nontoxic, odorless and colorless when produced. **For Your Safety**, LP gas has been given an odor (similar to rotten cabbage) so that it can be smelled.
- LP gas is highly flammable and may ignite unexpectedly when mixed with air.

LP Tank Filling

- Use only licensed and experienced dealers.
- LP dealer **must purge new tank** before filling.
- Dealer should **NEVER** fill LP Tank more than 80% of LP Tank volume. Volume of propane in tank will vary by temperature.
- A frosty regulator indicates gas overfill. Immediately close LP Tank valve and call local LP gas dealer for assistance.
- Do not release liquid propane (LP) gas into the atmosphere. This is a hazardous practice.
- To remove gas from LP Tank, contact an LP dealer or call a local fire department for assistance. Check the telephone directory under "Gas Companies" for nearest certified LP dealers.

LP Tank Exchange

- Many retailers that sell grills offer you the option of replacing your empty LP tank through an exchange service. Use only those reputable exchange companies that inspect, precision fill, test and certify their tanks. **Exchange your tank only for an OPD safety feature-equipped tank as described in the "LP Tank" section of this manual.**
- Always keep new and exchanged LP tanks in upright position during use, transit or storage.
- **Leak test new and exchanged LP tanks BEFORE connecting to grill.**
- Place dust cap on cylinder valve outlet whenever the cylinder is not in use. Only install the type of dust cap on the cylinder valve outlet that is provided with the cylinder valve. Other types of caps or plugs may result in leakage of propane.

LP Tank Leak Test

For your safety

- Leak test must be repeated each time LP tank is exchanged or refilled.
- Do not smoke during leak test.
- Do not use an open flame to check for gas leaks.
- Grill must be leak tested outdoors in a well-ventilated area, away from ignition sources such as gas fired or electrical appliances. During leak test, keep grill away from open flames or sparks.
- Use a clean paintbrush and a 50/50 mild soap and water solution. Brush soapy solution onto areas indicated by arrows in figure below. Leaks are indicated by growing bubbles.

	WARNING	
If "growing" bubbles appear do not use or move the LP tank. Contact an LP gas supplier or your fire department!		

- ▲ **Do not use household cleaning agents.** Damage to gas valve/hose/regulator components can result.

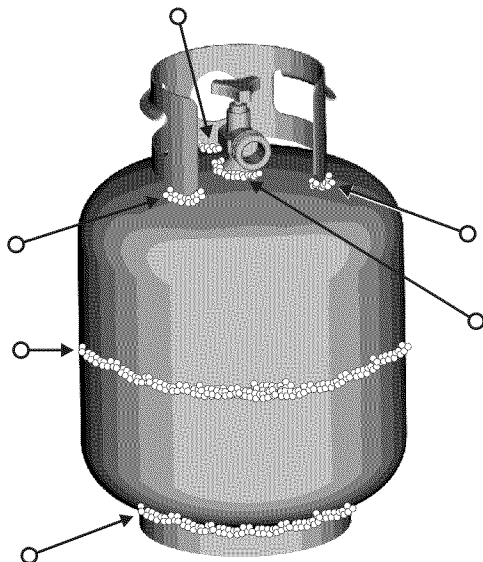

Connecting Regulator To The LP Tank

1. LP tank must be properly secured onto grill. (Refer to assembly section.)
2. Turn all control knobs to the OFF position.
3. Turn LP tank OFF by turning OPD hand wheel clockwise to a **full stop**.
4. Remove the protective cap from LP tank valve. Always use cap and strap supplied with valve.

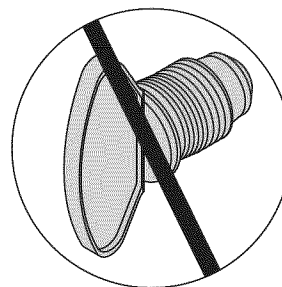
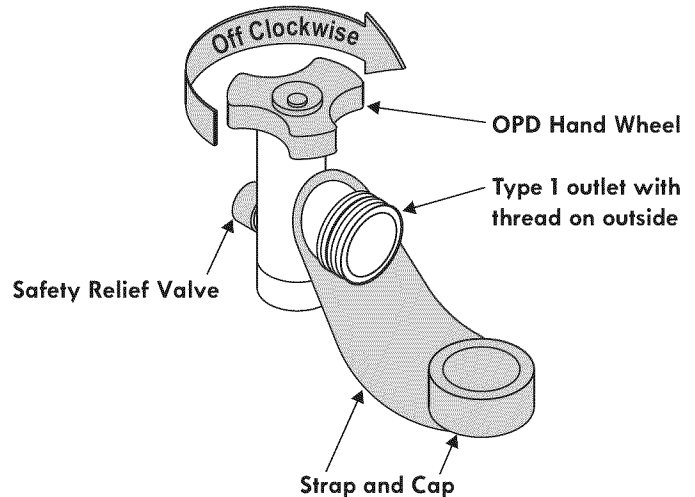

Do not insert a POL transport plug (plastic part with external threads) into the Type 1 tank valve outlet. It will defeat the Safety Relief Valve feature.

5. Hold regulator and insert nipple into LP tank valve. Hand-tighten the coupling nut, holding regulator in a straight line with LP tank valve so as not to cross-thread the connection.

Nipple has to be centered into the LP tank valve.

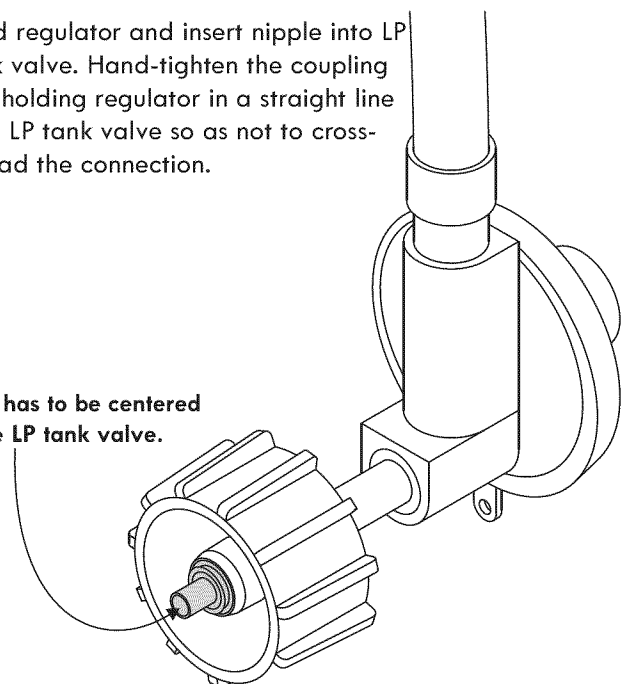

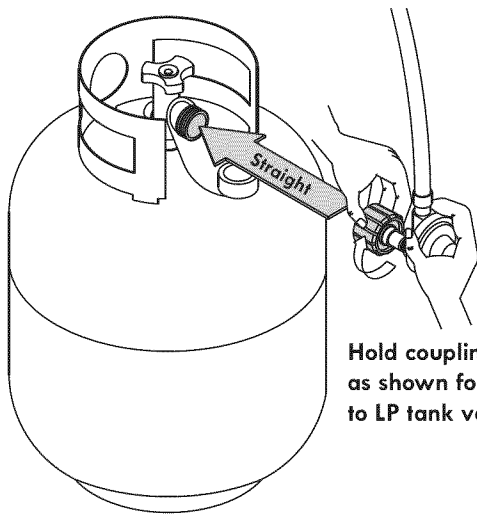

Hold coupling nut and regulator as shown for proper connection to LP tank valve.

6. Turn the coupling nut clockwise and tighten to a full stop. The regulator will seal on the back-check feature in the LP tank valve, resulting in some resistance. **An additional one-half to three-quarters turn is required to complete the connection. Tighten by hand only – do not use tools.**

NOTE:

If you cannot complete the connection, disconnect regulator and repeat steps 5 and 6. If you are still unable to complete the connection, **do not use this regulator!**

Call **1-800-4-MY-HOME®** for identical replacement parts.

⚠	DANGER	⚠
<ul style="list-style-type: none"> • Do not insert any tool or foreign objects into the valve outlet or safety relief valve. You may damage the valve and cause a leak. Leaking propane may result in explosion, fire, severe personal injury, or death. • If a leak is detected at any time, STOP and call the fire department. • If you cannot stop a gas leak, immediately close LP tank valve and call LP gas supplier or your fire department! 		

⚠	WARNING	⚠
<ul style="list-style-type: none"> • Never attempt to attach this grill to the self-contained LP gas system of a camper trailer or motor home. • Do not use grill until leak-tested. 		

Leak Testing Valves, Hose and Regulator

1. Turn all grill control knobs to OFF.
2. Be sure regulator is tightly connected to LP tank.
3. Completely open LP tank valve by turning OPD hand wheel counterclockwise. If you hear a rushing sound, turn gas off immediately. There is a major leak at the connection. **Correct before proceeding** by calling Sears for replacement parts at **1-800-4-MY-HOME®**.
4. Brush soapy solution onto areas where bubbles are shown in picture below:

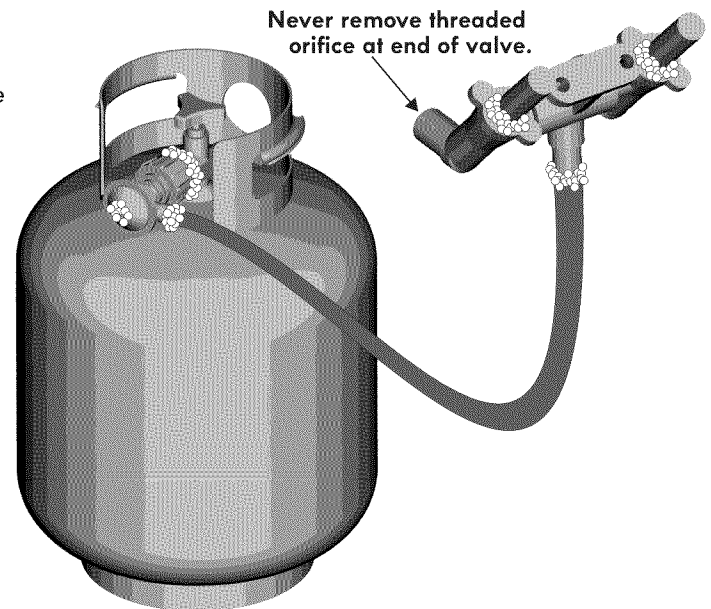

5. If **“growing”** bubbles appear, there is a leak. Close LP tank valve immediately and retighten connections. **If leaks cannot be stopped do not try to repair.** Call Sears for replacement parts at **1-800-4-MY-HOME®**.
6. Always close LP tank valve after performing leak test by turning hand wheel clockwise.

WARNING

For Safe Use of Your Grill and to Avoid Serious Injury:

- Do not let children operate or play near grill.
- Keep grill area clear and free from materials that burn.
- Do not block holes in sides or back of grill.
- Check burner flames regularly.
- Use grill only in well-ventilated space. NEVER use in enclosed space such as carport, garage, porch, covered patio, or under an overhead structure of any kind.
- Do not use charcoal or ceramic briquets in a gas grill. (Unless briquets are supplied with your grill.)
- **Use grill at least 3 ft. from any wall or surface.** Maintain 10 ft. clearance to objects that can catch fire or sources of ignition such as pilot lights on water heaters, live electrical appliances, etc.

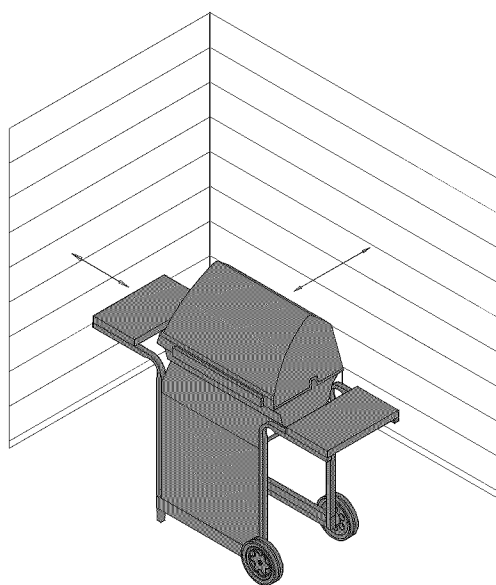

- **Apartment Dwellers:** Check with management to learn the requirements and fire codes for using an LP gas grill in your apartment complex. If allowed, use outside on the ground floor with a three (3) foot clearance from walls or rails. Do not use on or under balconies.
- **NEVER attempt to light burner with lid closed. A buildup of non-ignited gas inside a closed grill is hazardous.**
- **Never operate grill with LP cylinder out of correct position specified in assembly instructions.**
- **Always close LP cylinder valve and remove coupling nut before moving LP cylinder from specified operation position.**

Safety Tips

- ▲ Before opening LP cylinder valve, check the coupling nut for tightness.
- ▲ When grill is not in use, turn off all control knobs and LP cylinder valve.
- ▲ Never move grill while in operation or still hot.
- ▲ Use long-handled barbecue utensils and oven mitts to avoid burns and splatters.
- ▲ Maximum load for sideburner and side shelf is 10 lbs.
- ▲ The grease tray must be inserted into grill and emptied after each use. Do not remove grease tray until grill has completely cooled.
- ▲ Clean grill often, preferably after each cookout. If a bristle brush is used to clean any of the grill cooking surfaces, ensure no loose bristles remain on cooking surfaces prior to grilling. It is not recommended to clean cooking surfaces while grill is hot.
- ▲ If you notice grease or other hot material dripping from grill onto valve, hose or regulator, turn off gas supply at once. Determine the cause, correct it, then clean and inspect valve, hose and regulator before continuing. Perform a leak test.
- ▲ Keep ventilation openings in cylinder enclosure (grill cart) free and clear of debris.
- ▲ Do not store objects or materials inside the grill cart enclosure that would block the flow of combustion air to the underside of either the control panel or the firebox bowl.
- ▲ The regulator may make a humming or whistling noise during operation. This will not affect safety or use of grill.
- ▲ If you have a grill problem see the "Troubleshooting Section".
- ▲ If the regulator frosts, turn off grill and LP cylinder valve immediately. This indicates a problem with the cylinder and it should not be used on any product. Return to supplier!

CAUTION



- **Putting out grease fires by closing the lid is not possible. Grills are well ventilated for safety reasons.**
- **Do not use water on a grease fire. Personal injury may result. If a grease fire develops, turn knobs and LP cylinder off.**
- **Do not leave grill unattended while preheating or burning off food residue on HI. If grill has not been regularly cleaned, a grease fire can occur that may damage the product.**

Ignitor Lighting the Grill

- ▲ **Do not lean over grill while lighting.**
 1. Turn **OFF** gas burner control valves.
 2. **Open lid during lighting.**
 3. Turn **ON** gas tank valve.
 4. Push and turn burner control knob to **HI** and immediately press and hold **ELECTRONIC IGNITION** button.
 5. If ignition does NOT occur in 5 seconds, turn burner control knob **OFF**, wait 5 minutes for gas to clear away, and repeat the lighting procedure.
 6. Repeat above steps to light each burner individually.
 7. Once each burner has ignited, turn knobs to desired setting. If ignitor does not work, follow match lighting instructions.

Lighting instructions are continued on the next page

	WARNING	
Turn controls and gas source or tank OFF when not in use.		

	CAUTION	
If ignition does NOT occur in 5 seconds, turn the burner controls OFF , wait 5 minutes and repeat the lighting procedure. If the burner does not ignite with the valve open, gas will continue to flow out of the burner and could accidentally ignite with risk of injury.		

Match-Lighting

▲ **Do not lean over grill while lighting.**

1. **Open lid.** Turn **ON** gas at LP cylinder.
2. Place match into match holder (hanging from side panel of grill). Light match; then light burner by placing match through the match light hole on right or left side of grill.
3. Push in and turn far right or far left burner knob to the **HI** position, depending on match light hole selected. Be sure burner lights and stays lit.
4. Light adjacent burners in sequence by pushing knobs in and turning to the **HI** position.

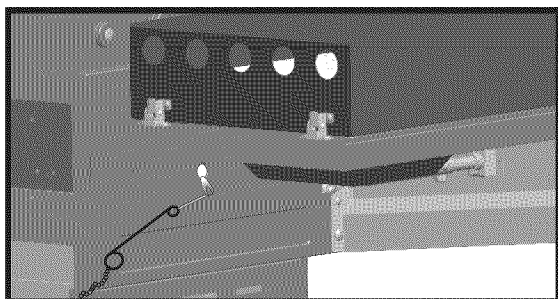

Sideburner Ignitor Lighting

▲ **Do not lean over grill while lighting.**

1. **Open sideburner lid.** Turn **ON** gas at LP cylinder.
2. Turn sideburner knob to the **HI** position, push and hold **ELECTRONIC IGNITION** button.
3. If sideburner does **NOT** light within 5 seconds, turn knob to **OFF**, wait 5 minutes, then repeat lighting procedure.

Sideburner Match Lighting

1. **Open sideburner lid.** Turn **ON** gas at LP cylinder.
2. Place lit match near burner.
3. Turn sideburner knob to the **HI** position. Be sure burner lights and stays lit.

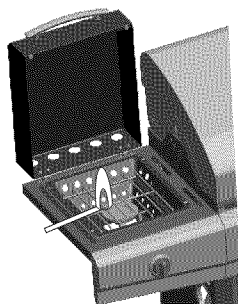

Burner Flame Check

- Remove cooking grates and flame tamers. Light burners, rotate knobs from **HI** to **LOW**. You should see a smaller flame in **LOW** position than seen on **HI**. Perform burner flame check on sideburner, also. Always check flame prior to each use. If only low flame is seen refer to "Sudden drop or low flame" in the Troubleshooting Section.

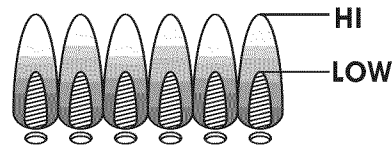

Turning Grill Off

- Turn all knobs to the **OFF** position. Turn LP cylinder **OFF** by turning hand-wheel clockwise to a full stop.

Ignitor Check

- **Turn gas off at LP cylinder.** Press and hold electronic ignitor button. "Click" should be heard and spark seen each time between each collector box or burner and electrode. See "Troubleshooting" if no click or spark.

Valve Check

- **Important: Make sure gas is off at LP cylinder before checking valves.** Knobs lock in **OFF** position. To check valves, first push in knobs and release, knobs should spring back. If knobs do not spring back, replace valve assembly before using grill. Turn knobs to **LOW** position then turn back to **OFF** position. Valves should turn smoothly.

Hose Check

- Before each use, check to see if hoses are cut or worn. Replace damaged hoses before using grill. Use only identical replacement part valve/hose/regulator as specified in the Parts List of this Use and Care Guide.

General Grill Cleaning

- Do not mistake brown or black accumulation of grease and smoke for paint. Interiors of gas grills are not painted at the factory (**and should never be painted**). Apply a strong solution of detergent and water or use a grill cleaner with scrub brush on insides of grill lid and bottom. Rinse and allow to completely air dry. **Do not apply a caustic grill/oven cleaner to painted surfaces.**
- **Plastic parts:** Wash with warm soapy water and wipe dry.
 - ▲ Do not use citrisol, abrasive cleaners, degreasers or a concentrated grill cleaner on plastic parts. Damage to and failure of parts can result.
- **Porcelain surfaces:** Because of glass-like composition, most residue can be wiped away with baking soda/water solution or specially formulated cleaner. Use nonabrasive scouring powder for stubborn stains.
- **Painted surfaces:** Wash with mild detergent or nonabrasive cleaner and warm soapy water. Wipe dry with a soft nonabrasive cloth.
- **Stainless steel surfaces:** To maintain your grill's high quality appearance, wash with mild detergent and warm soapy water and wipe dry with a soft cloth after each use. Baked-on grease deposits may require the use of an abrasive plastic cleaning pad. Use only in direction of brushed finish to avoid damage. Do not use abrasive pad on areas with graphics.
- **Cooking surfaces:** If a bristle brush is used to clean any of the grill cooking surfaces, ensure no loose bristles remain on cooking surfaces prior to grilling. It is not recommended to clean cooking surfaces while grill is hot.



CAUTION



SPIDER ALERT!

SPIDER AND WEBS
INSIDE BURNER TUBE

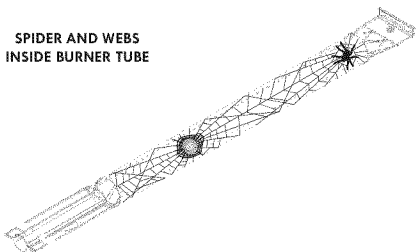

If you notice that your grill is getting hard to light or that the flame isn't as strong as it should be, take the time to check and clean the burner tubes.

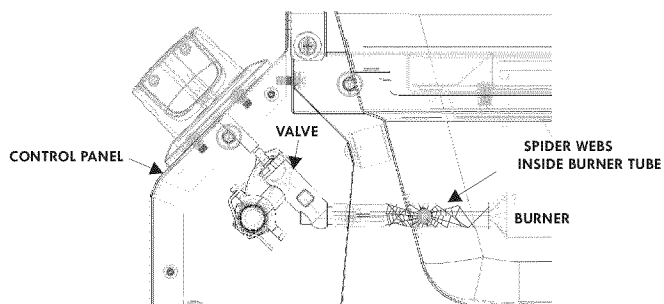

Spiders or small insects have been known to create "flashback" problems. The spiders spin webs, build nests and lay eggs in the grill's burner tube(s) obstructing the flow of gas to the burner. The backed-up gas can ignite in the burner tube behind the control panel. This is known as a flashback and it can damage your grill and even cause injury.

To prevent flashbacks and ensure good performance the burner and burner tube assembly should be removed from the grill and cleaned before use whenever the grill has been idle for an extended period.

Storing Your Grill

- Clean cooking grates.
- Store in dry location.
- When LP cylinder is connected to grill, store outdoors in a well-ventilated space and out of reach of children.
- Cover grill if stored outdoors. Choose from a variety of grill covers offered by manufacturers.
- Store grill indoors ONLY if LP cylinder is turned off and disconnected, removed from grill and stored outdoors.
- When removing grill from storage, follow "Cleaning the Burner Assembly" instructions before starting grill.

Cleaning the Burner Assembly

Follow these instructions to clean and/or replace parts of burner assembly or if you have trouble igniting grill.

1. Turn gas OFF at control knobs and LP cylinder.
2. Remove cooking grates and flame tamers.

3. Remove carryover tubes and burners.
4. Detach electrode from burner.

NOTE: Removal/Detachment method will depend on the burner configuration. See different configurations in illustrations below.

5. Carefully lift each burner up and away from valve openings. We suggest three ways to clean the burner tubes. Use the one easiest for you.
 - (A) Bend a stiff wire (a light weight coat hanger works well) into a small hook. Run the hook through each burner tube several times.



(B) Use a narrow bottle brush with a flexible handle (do not use a brass wire brush), run the brush through each burner tube several times.

(C) **Wear eye protection:** Use an air hose to force air into the burner tube and out the burner ports. Check each port to make sure air comes out each hole.

6. Wire brush entire outer surface of burner to remove food residue and dirt.
7. Clean any blocked ports with a stiff wire such as an open paper clip.
8. Check burner for damage, due to normal wear and corrosion some holes may become enlarged. If any large cracks or holes are found replace burner.

VERY IMPORTANT: Burner tubes must reengage valve openings. See illustration at right.

9. Attach electrode to burner.
10. Carefully replace burners.
11. Attach burners to brackets on firebox.
12. Reposition carryover tubes and attach to burners. Replace flame tamers and cooking grates.

Correct
burner-to-valve
engagement

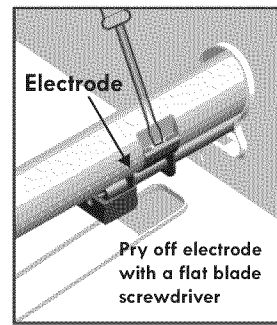
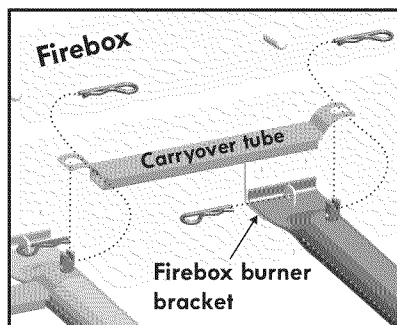
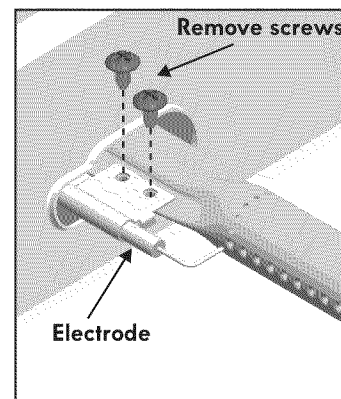
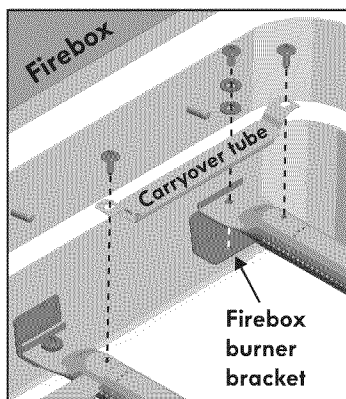
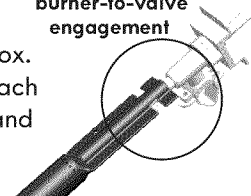

Indirect Cooking

Poultry and large cuts of meat cook slowly to perfection on the grill by indirect heat. Place food over unlit burner(s); the heat from lit burners circulates gently throughout the grill, cooking meat or poultry without the touch of a direct flame. This method greatly reduces flare-ups when cooking extra fatty cuts because there is no direct flame to ignite the fats and juices that drip during cooking.

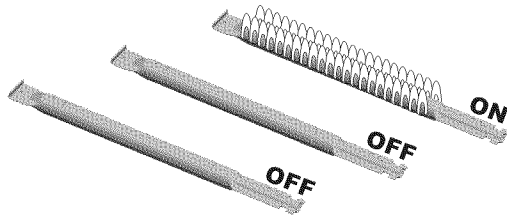

1 Burner Cooking

Cook with direct or indirect heat.
Best for smaller meals or foods.
Consumes less fuel.

Indirect Cooking Instructions

- Always cook with the lid closed.
- Due to weather conditions, cooking times may vary. During cold and windy conditions the temperature setting may need to be increased to insure sufficient cooking temperatures.
- Place food over the unlit burner(s).

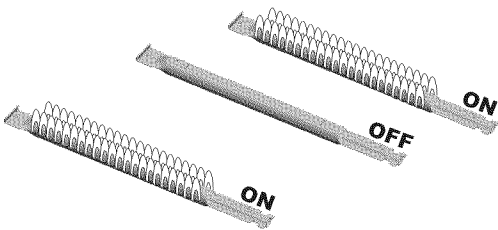

2 Burner Cooking

Great indirect cooking on low.
Produces slow, even heating.
Ideal for slow roasting and baking.

Food Safety

Food safety is a very important part of enjoying the outdoor cooking experience. To keep food safe from harmful bacteria, follow these four basic steps:

- Clean:** Wash hands, utensils, and surfaces with hot soapy water before and after handling raw meat and poultry.
- Separate:** Separate raw meats and poultry from ready-to-eat foods to avoid cross contamination. Use a clean platter and utensils when removing cooked foods.
- Cook:** Cook meat and poultry thoroughly to kill bacteria. Use a thermometer to ensure proper internal food temperatures.

Chill: Refrigerate prepared foods and leftovers promptly.

For more information call: USDA Meat and Poultry Hotline at 1-800-535-4555 (In Washington, DC (202) 720-3333, 10:00 am-4:00 pm EST).

How To Tell If Meat Is Grilled Thoroughly

- Meat and poultry cooked on a grill often browns very fast on the outside. Use a meat thermometer to be sure food has reached a safe internal temperature, and cut into food to check for visual signs of doneness.
- Whole poultry should reach 165° F. Juices should run clear and flesh should not be pink.
- Hamburgers made of any ground meat or poultry should reach 160° F, and be brown in the middle with no pink juices. Beef, veal and lamb steaks, roasts and chops can be cooked to 145° F. All cuts of pork should reach 160° F.
- NEVER partially grill meat or poultry and finish cooking later. Cook food completely to destroy harmful bacteria.
- When reheating takeout foods or fully cooked meats like hot dogs, grill to 165° F, or until steaming hot.

WARNING: To ensure that it is safe to eat, food must be cooked to the minimum internal temperatures listed in the table below.

USDA* Safe Minimum Internal Temperatures	
Fish	145°F
Pork	160°F
Egg Dishes	160°F
Steaks and Roasts of Beef, Veal or Lamb	145°F
Ground Beef, Veal or Lamb	160°F
Whole Poultry (Turkey, Chicken, Duck, etc.)	165°F
Ground or Pieces Poultry (Chicken Breast, etc.)	165°F

*United States Department of Agriculture

PARTS LIST

Key	Qty	Description	Part #
1	2	LOCKING CASTER	G515-0082-W1
2	2	FIXED CASTER	G350-0024-W1
3	1	BOTTOM SHELF	G524-0600-W1
4	2	DOOR MAGNET ASSEMBLY	G501-0016-W1
5	1	TOWEL HOLDER	G524-7000-W1
6	1	RIGHT SIDE PANEL	G524-0400-W1
7	1	LEFT SIDE PANEL	G524-0300-W1
8	1	LOWER BACK PANEL	G524-0017-W1
9	1	GROMMET	G505-0039-W1
10	1	TANK EXCLUSION	G516-0039-W1
11	1	UPPER BACK PANEL, CART	G524-0016-W1
12	1	FRONT BRACE	G524-2100-W1
13	1	TANK HEAT SHIELD	G524-8000-W1
14	1	FIREBOX	G524-4000-W1
15	1	HEAT SHIELD, FIREBOX	G524-0007-W1
16	1	MATCH HOLDER AND CHAIN	G501-0068-W1
17	4	MAIN BURNER	G517-7300-W1
18A	2	ELECTRODE, F/MAIN BURNER, LONG WIRE	G515-0014-W1
18B	2	ELECTRODE, F/MAIN BURNER, SHORT WIRE	G515-0067-W1
19	3	FLAME CARRYOVER TUBE	G524-0036-W1
20	1	HOSE VALVE REGULATOR	G524-6000-W1
21	1	CONTROL PANEL	G524-0011-W1
22	1	IGNITER SWITCH MODULE	G518-0026-W3
23	5	BEZEL, F/ CONTROL KNOB	G513-0054-W1
24	5	CONTROL KNOB	G614-4400-W1
25	1	TOP LID	G524-0100-W1
26	1	HANDLE, F/ TOP LID	G521-0002-W2
27	2	END CAP, F/ HANDLE	G352-0015-W1
28	1	INNER INSERT, F/ TOP LID	G524-0001-W1
29	2	RUBBER BUMPER, RECTANGULAR, F/ LID	G413-0025-W1
30	2	RUBBER BUMPER, ROUND	G501-0066-W1
31	1	LOGO PLATE	G614-0097-W1
32	1	BEZEL, F/ TEMPERATURE GAUGE	G503-0002-W1
33	1	TEMPERATURE GAUGE	G518-0075-W1
34	1	HARDWARE F/ TOP LID ASSEMBLY	G515-0035-W1
35	1	ELECTRONIC IGNITION MODULE	G515-0030-W2
36	1	CAP, F/ ELECTRONIC IGNITION MODULE	G515-0030-W1
37	1	TOWEL BAR	G511-0034-W1
38	1	RIGHT SHELF	G524-0800-W1
39	1	FASCIA, F/ RIGHT SHELF	G524-0024-W1
40	1	SIDE SHELF EXTENDER	G524-0025-W1
41	1	LEFT SIDEBURNER SHELF	G524-0700-W1
42	1	FASCIA, F/ SB SHELF	G524-0023-W1

Key	Qty	Description	Part #
43	1	SIDEBURNER PAN	G515-0083-W2
44	1	LID, F/ SIDE BURNER	G501-0070-W1
45	1	RUBBER BUMPER, F/ SB	G508-0033-W1
46	1	SIDEBURNER	G511-5100-W1
47	1	ELECTRODE, F/ SIDEBURNER	G515-0039-W1
48	1	ELECTRODE WIRE, F/ SIDEBURNER	G401-0038-W1
49	1	SIDEBURNER GRATE	G501-0077-W1
50	1	RIGHT DOOR, NO HANDLE	G524-2300-W1
51	2	DOOR HANDLE	G517-0011-W1
52	1	LEFT DOOR, NO HANDLE	G524-2200-W1
53	4	HEAT DIFFUSER	G524-0032-W1
54	1	WARMING RACK	G524-0002-W1
55	3	COOKING GRATE, MAIN	G524-0003-W1
56	1	GREASE TRAY	G350-4400-W1A
57	1	CYLINDER SCREW F/ TANK SECURE	G505-0047-W1
58	1	STEAMER TRAY LID	G524-0026-W1
59	1	STEAMER TRAY HANDLE	G524-0027-W1
60	1	STEAMER TRAY	G524-0028-W1
61	1	STEAMER TRAY BRACE	G524-2700-W1
62	1	STEAMER HANDLE TOOL	G524-0029-W1

NOT Picture:

Key	Qty	Description	Part #
...	1	CASTER PIN	G350-0026-W1
...	1	HARDWARE PACK	G524-B001-W1
...	1	ASSEMBLY MANUAL, ENGLISH	G524-010801-W1
...	1	ASSEMBLY MANUAL, SPANISH	G524-010802-W1

If you are missing hardware or have damaged parts after unpacking grill, call 1-800-241-7548 for replacement.

To order replacement parts after using grill, call 1-800-4-MY-HOME[®]

NOTE: Some grill parts shown in the assembly steps may differ slightly in appearance from those on your particular grill model. However, the method of assembly remains the same.

PARTS DIAGRAM

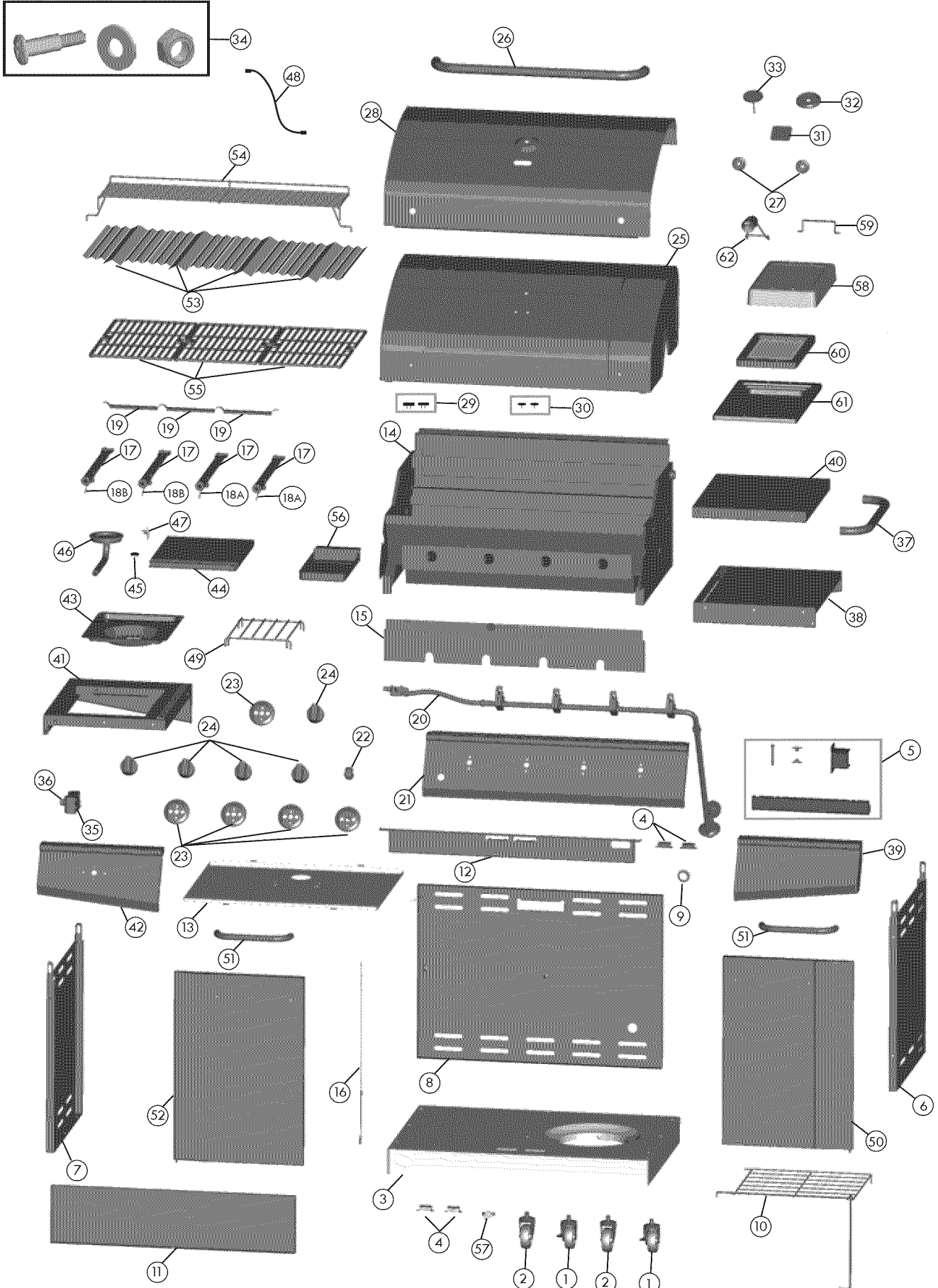

ASSEMBLY

- 1 Place bottom shelf upside down. Insert Bent U Pin into the caster mounting plate to lock it in place, shown A. Spin the caster clockwise into the threads on the bottom shelf until secure. Remove the Bent U Pin and repeat for remaining casters. Make sure the two locking casters are secured at the rear and the non-locking casters are secured at the front. After all 4 casters are secure remove the Bent U Pin and save for future maintenance.

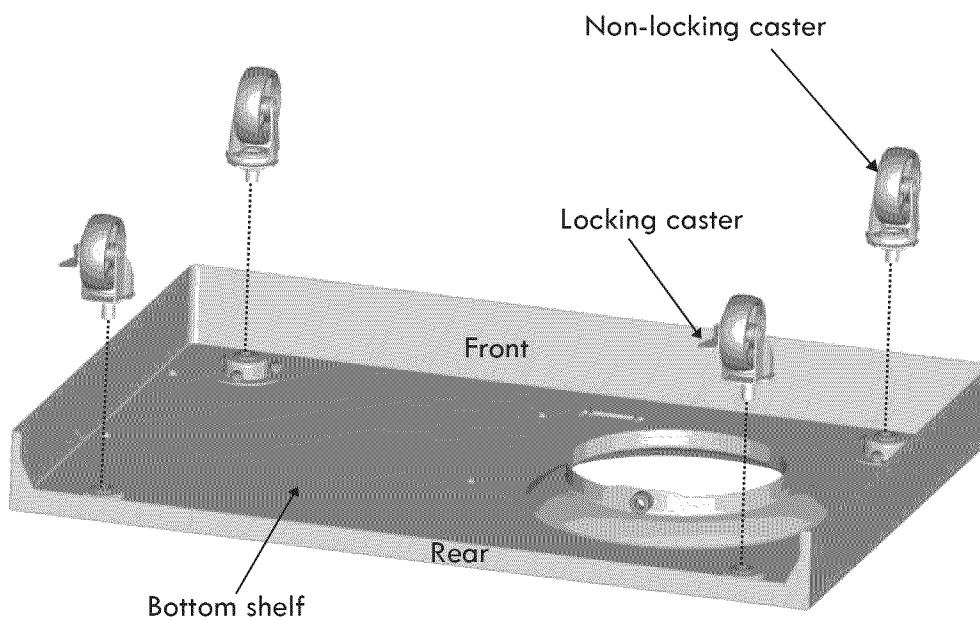
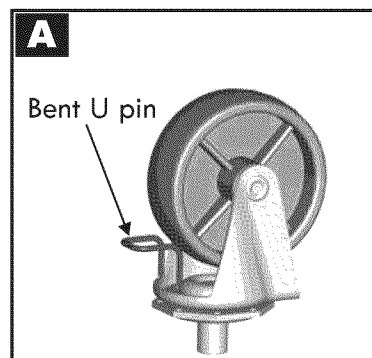
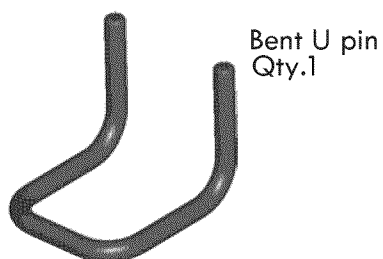

2

Attach towel holder to cart right side panel using two 1/4-20x1/2" screws, 7mm lock washers, 7mm flat washers and 1/4" nut.



1/4-20x1/2" screw
Qty.2



7mm lock washer
Qty.2



7mm flat washer
Qty.2



1/4" nut
Qty.2

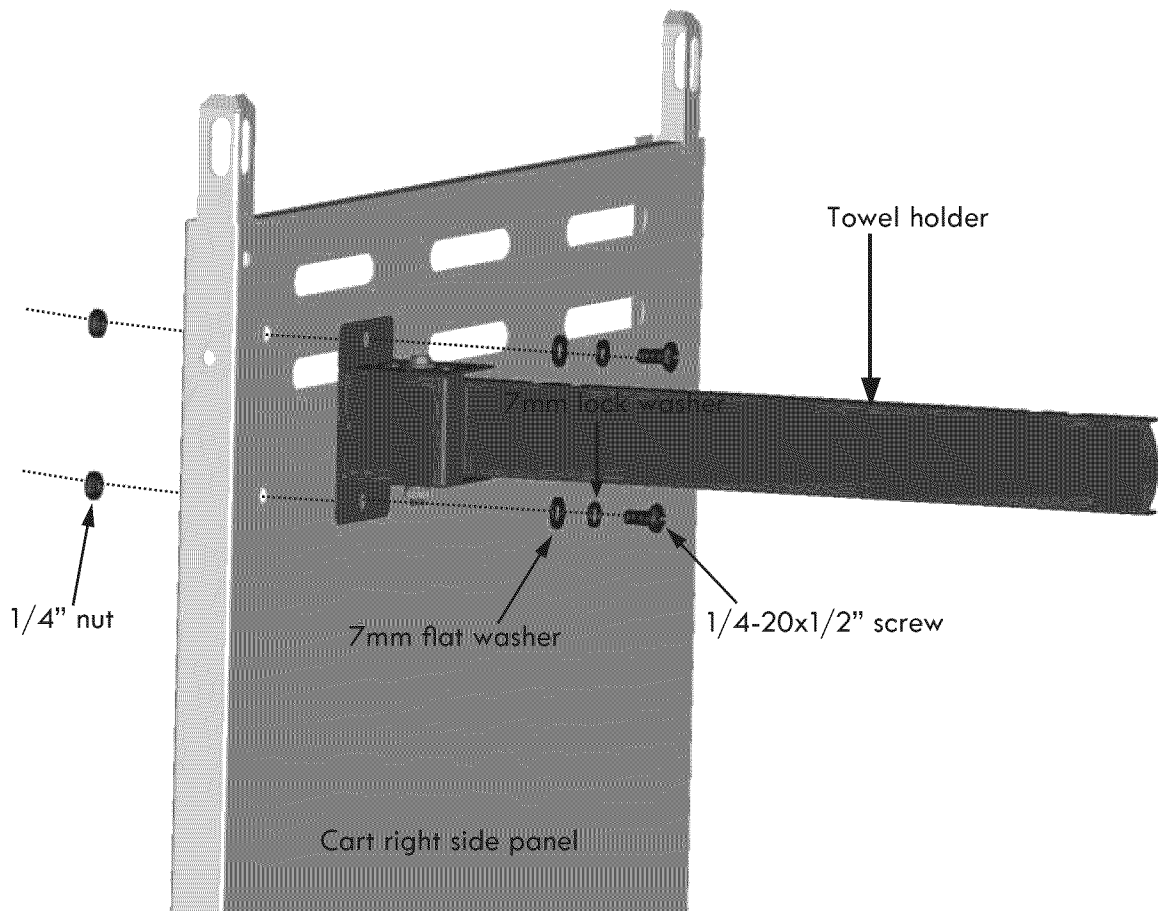

3

Attach side panels to bottom shelf using three 1/4-20x1/2" screws, 7mm lock washers, and 7mm flat washers per panel.

IMPORTANT: Panel with Electronic Ignition Module hole must be attached to Left side of bottom shelf.

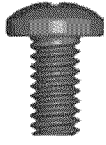

1/4-20x1/2" screw
Qty.6



7mm lock washer
Qty.6



7mm flat washer
Qty.6

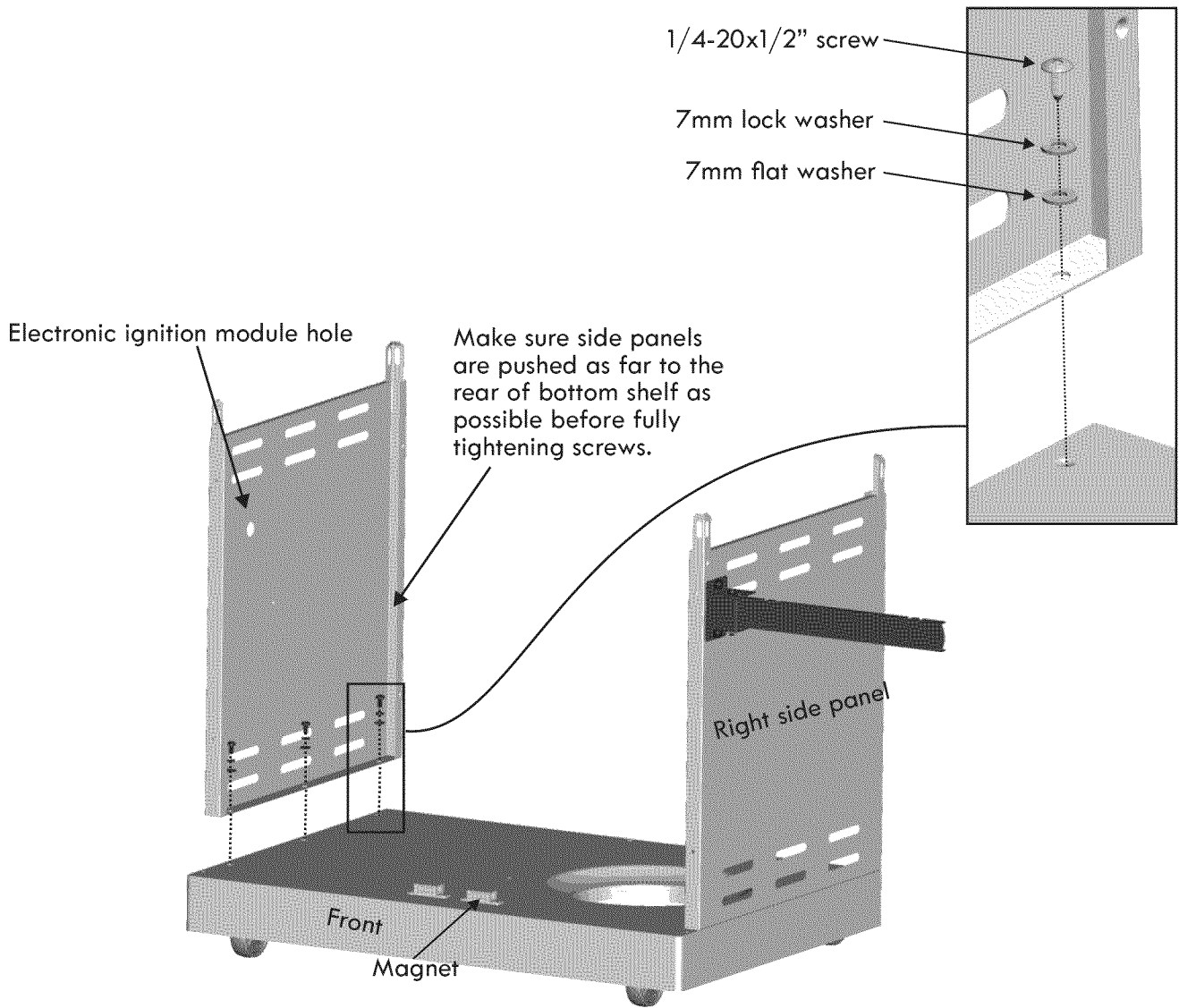

4

Place lower back panel between side panels at rear of bottom shelf.

Secure lower back panel to side panels using two 1/4-20x1/2" screws, 7mm lock washers and 7mm flat washers on each side.

Secure lower back panel to bottom shelf using one 1/4-20x1/2" screw, 7mm lock washer and 7mm flat washer.



1/4-20x1/2" screw
Qty.5



7mm lock washer
Qty.5

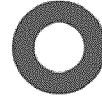

7mm flat washer
Qty.5

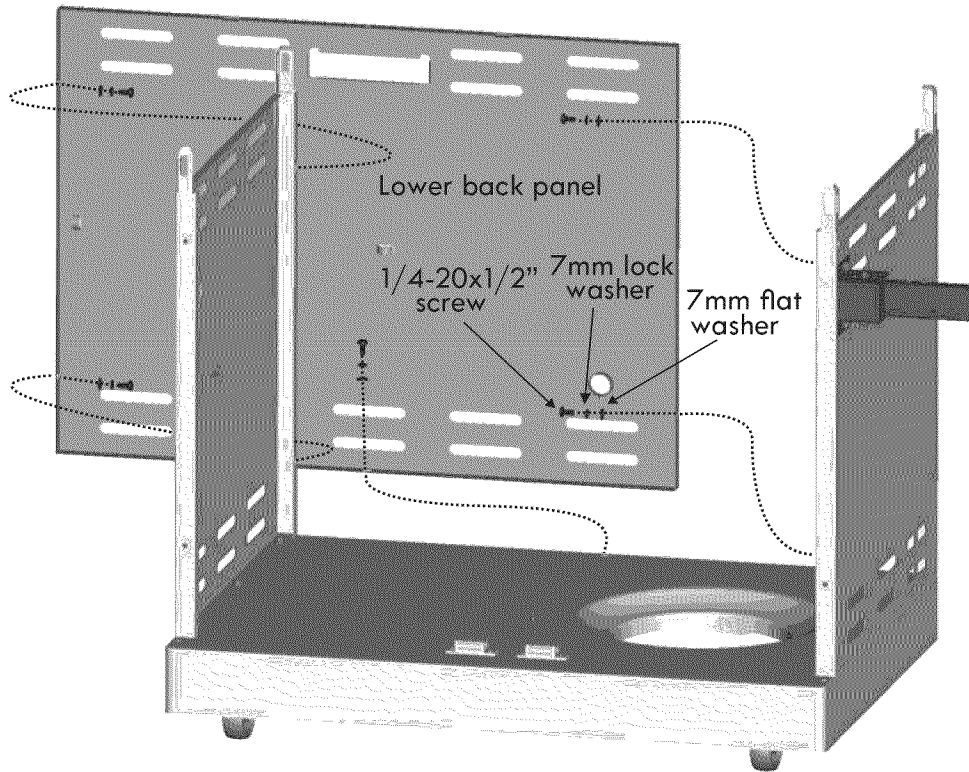

5

Inside of cart, insert tank exclusion wire shelf ends into lower back panel, shown A.

Attach front left side of wire shelf to cart left side panel with one #8-32x3/8" screw, 4mm lock washer and 4mm flat washer. Attach leg to bottom shelf with one #8-32x3/8" screw, 4mm lock washer and 4mm flat washer, shown B.



#8-32x3/8" screw
Qty.2



4mm lock washer
Qty.2



4mm flat washer
Qty.2

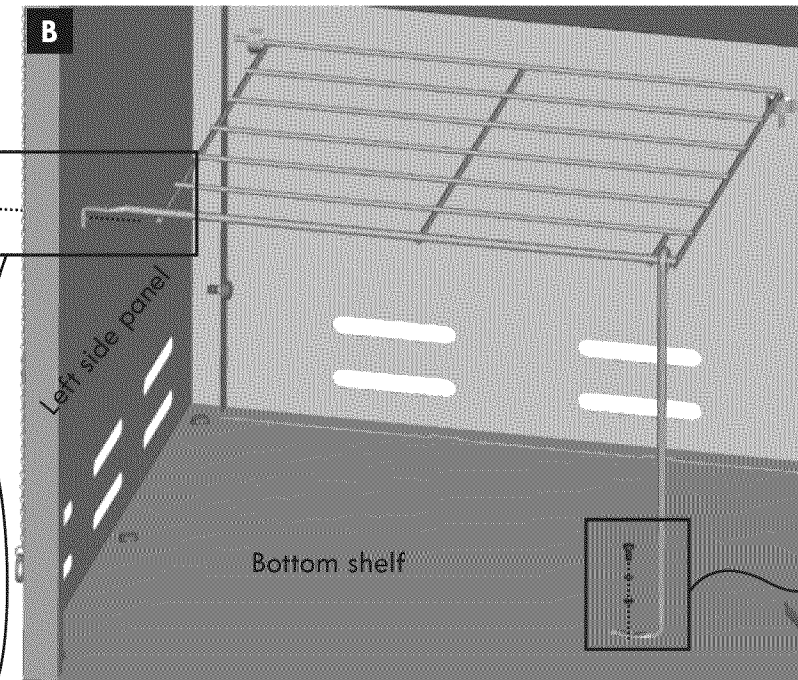
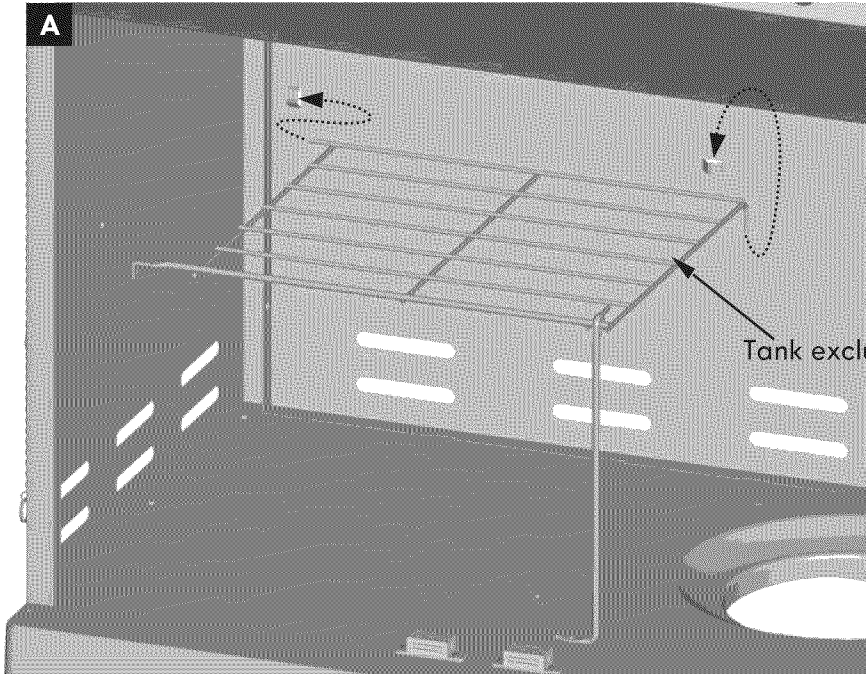

#8-32x3/8" screw

#8-32x3/8" screw

4mm lock washer

4mm flat washer

4mm lock washer

4mm flat washer

6

Insert front brace between cart side panels. Make sure door hinge pins are on the top side and facing the front. Secure using one 1/4-20x1 1/2" screw, 7mm lock washer and 7mm flat washer on each side.

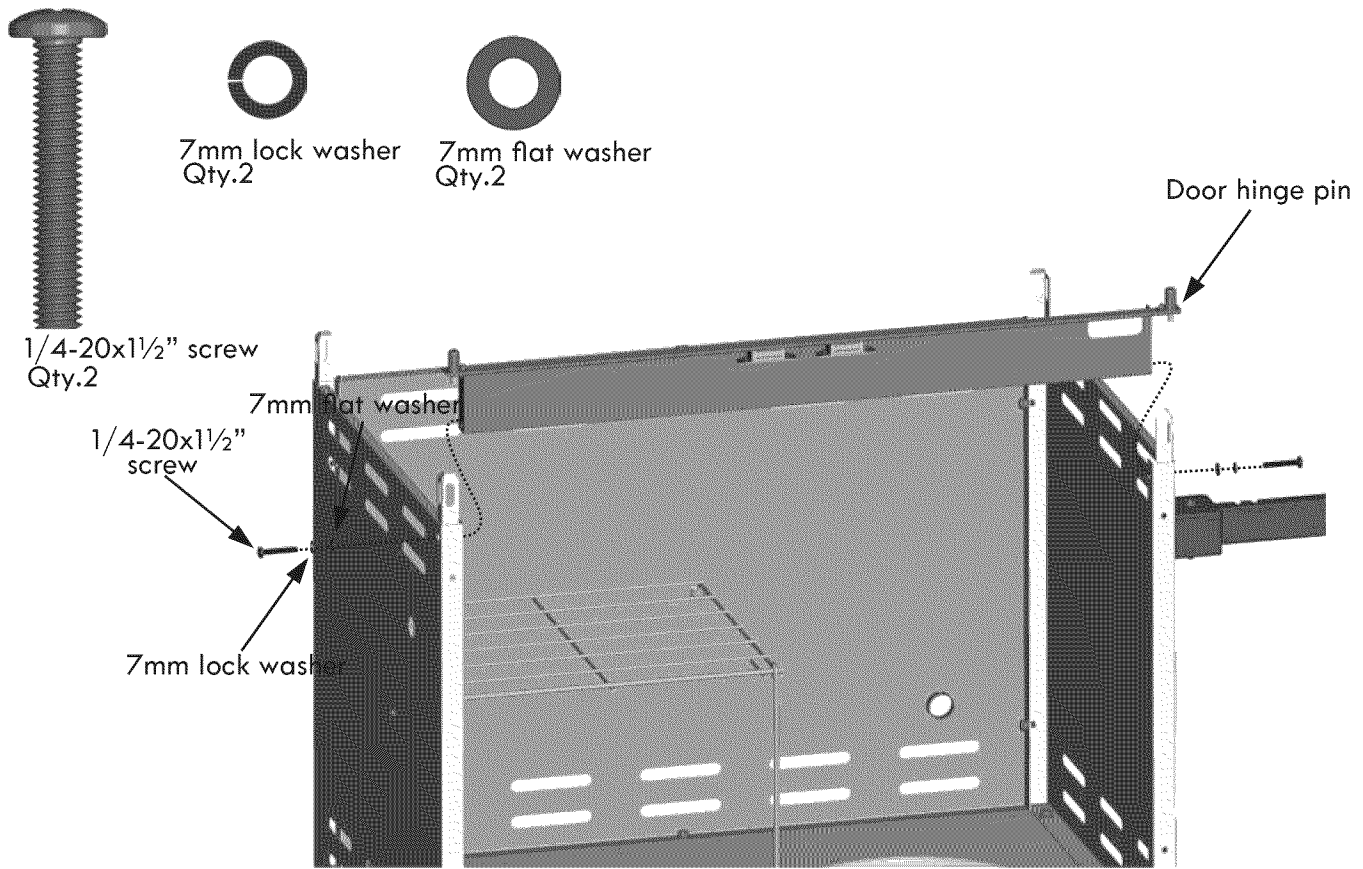

7

Attach middle of upper back panel to lower back panel using one 1/4-20x1 1/2" screw, 7mm lock washer and 7mm flat washer.

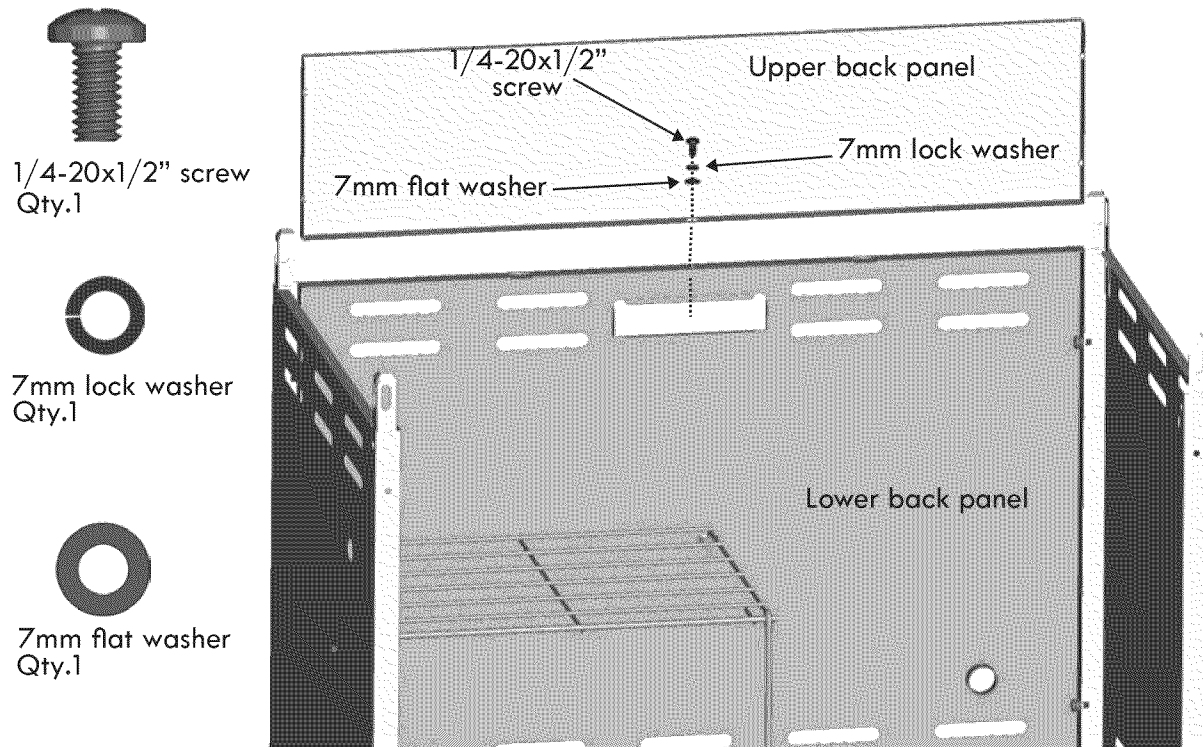

Note: front brace omitted for clarity of illustration.

- 8** Insert tank heat shield tabs (without holes) into slots between upper back panel and lower back panel, shown A.
Attach tank heat shield front tabs (with holes) under front brace using two #8x3/8" self-tapping screws, shown B.



#8x3/8" self-tapping screw
Qty. 2

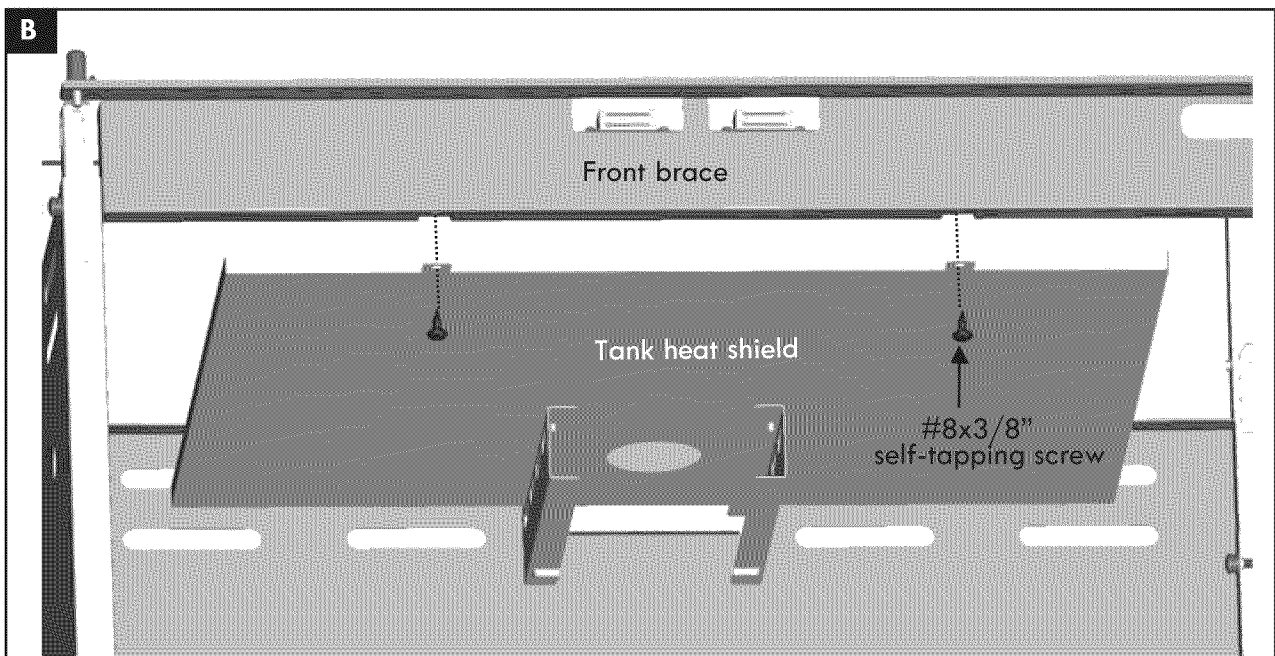
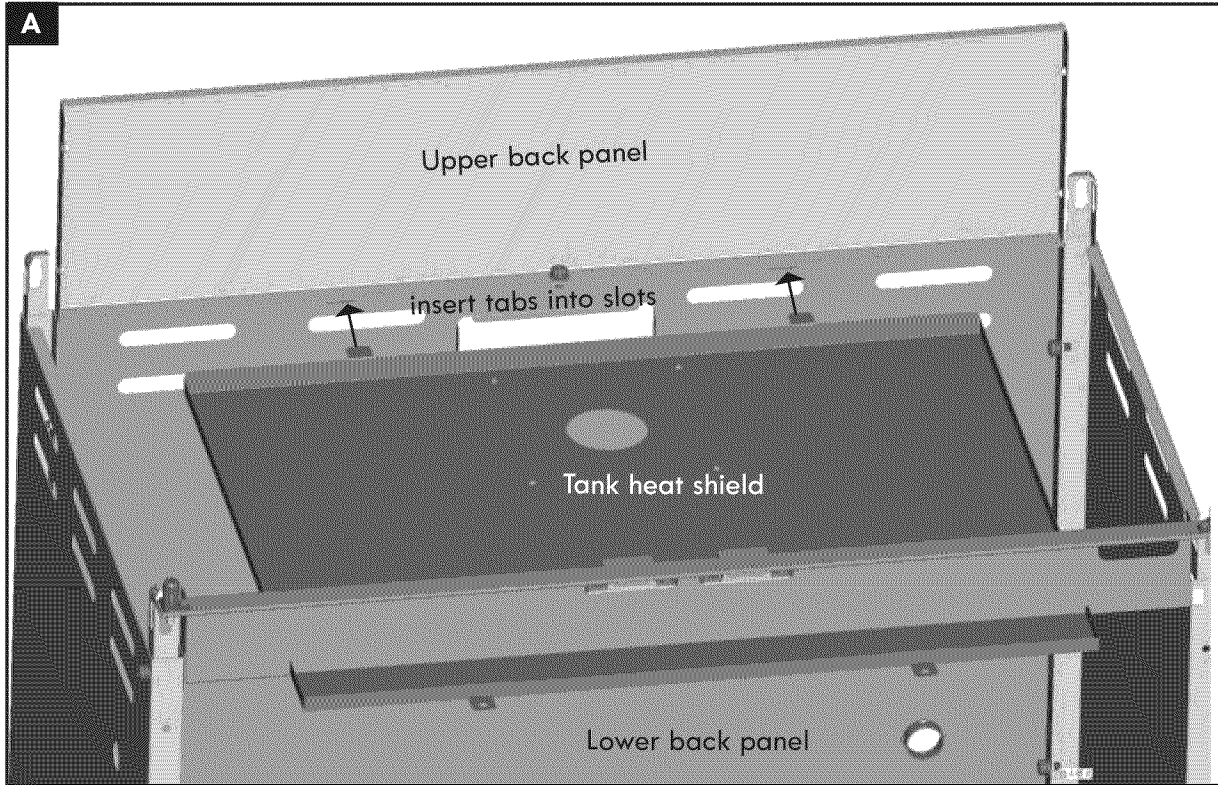

9

This step requires two people to lift and position grill head onto cart. Remove tie wrap holding regulator hose to bottom of grill head. Remove packing material. Loosen tie wrap holding ignition wires to bottom of grill head. Retain tie wrap to bundle ignition wires together. Carefully lower the grill head onto the cart, aligning slots at bottom of grill head with posts on cart side panels. Regulator hose must hang inside the cart. Grill head must face open side of cart.

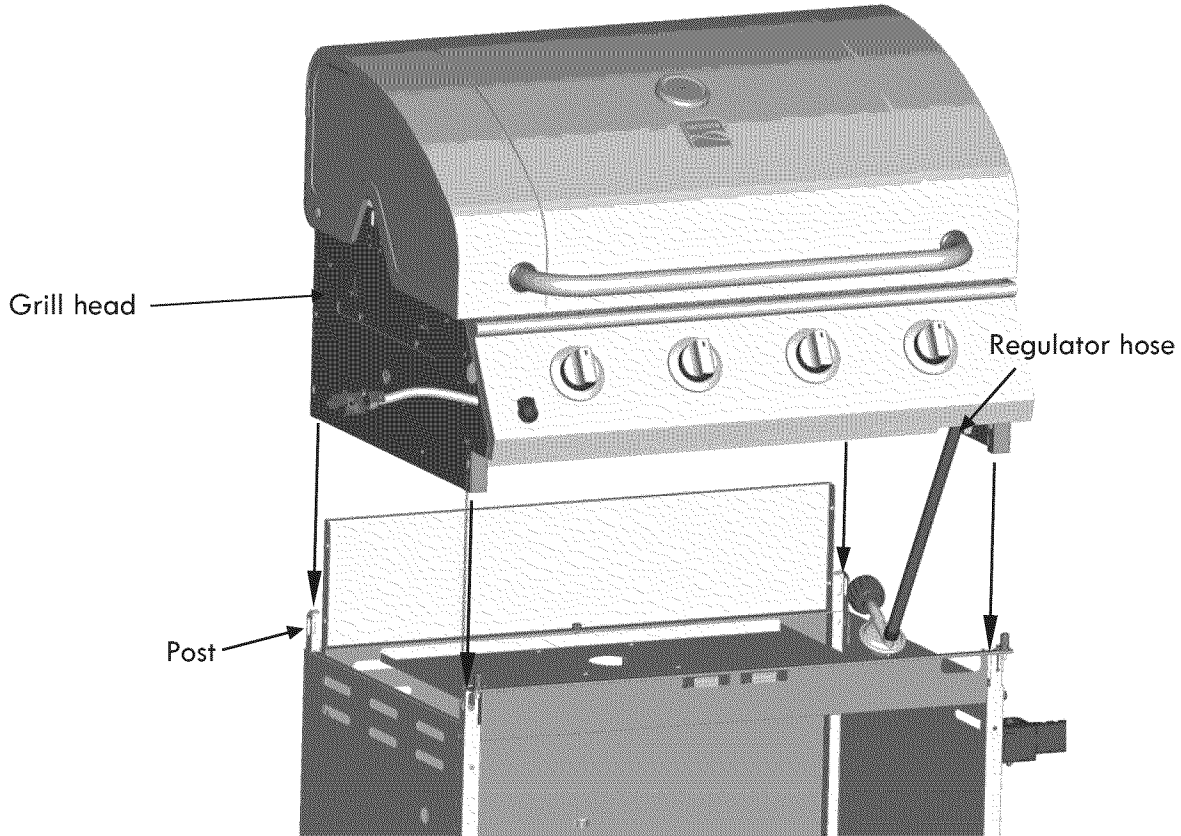

10

Secure front brace in upper hole with one 1/4-20x1 1/2" screw, 7mm lock washer and 7mm flat washer, shown A. Secure upper back panel in lower hole with one 1/4-20x1 1/2" screw, 7mm lock washer and 7mm flat washer, shown B. Only left side shown; repeat above instructions for right side.

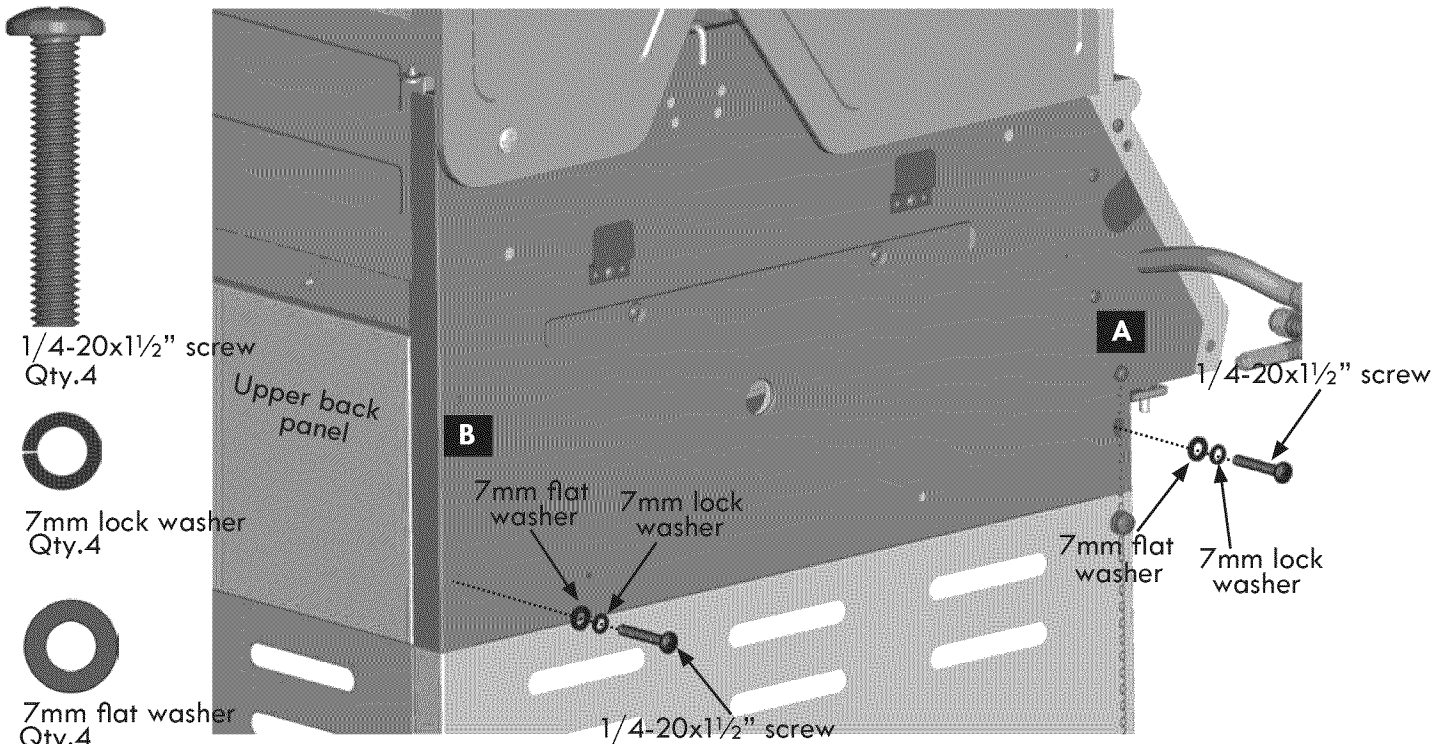

11

Inside of cart, connect the five wires from burner electrodes into the back of Electronic Ignition module, positions 1 - 5, shown A. Connect the two wires [(a) and (b)] from switch wiring harness into the back of Electronic Ignition module, shown A.

Note: Switch terminals are larger than electrode terminals and should only be installed in locations (a) and (b).

Remove the cap and nut from electronic ignition module. Attach electronic ignition module to the cart left side panel with the nut, shown B.

Insert AA battery into ignition module, negative (-) end first. Then put on the cap, shown C.

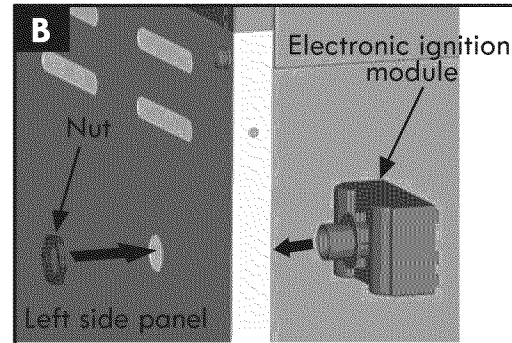
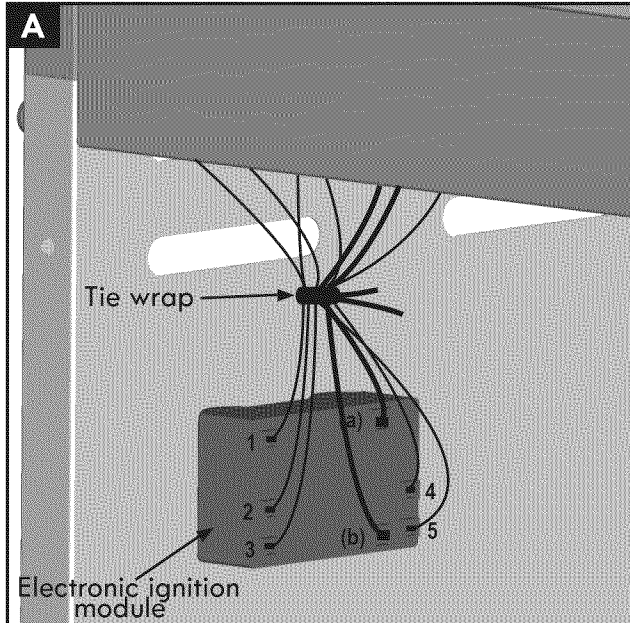

NOTE: Wires omitted for clarity of illustration.

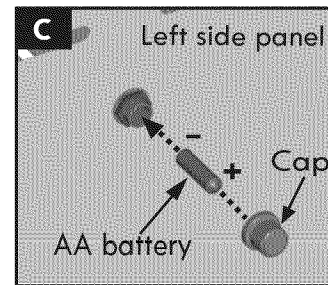

12

Attach towel bar to right side extended shelf using two 1/4-20x1/2" screws, 7mm lock washers and 7mm flat washers.

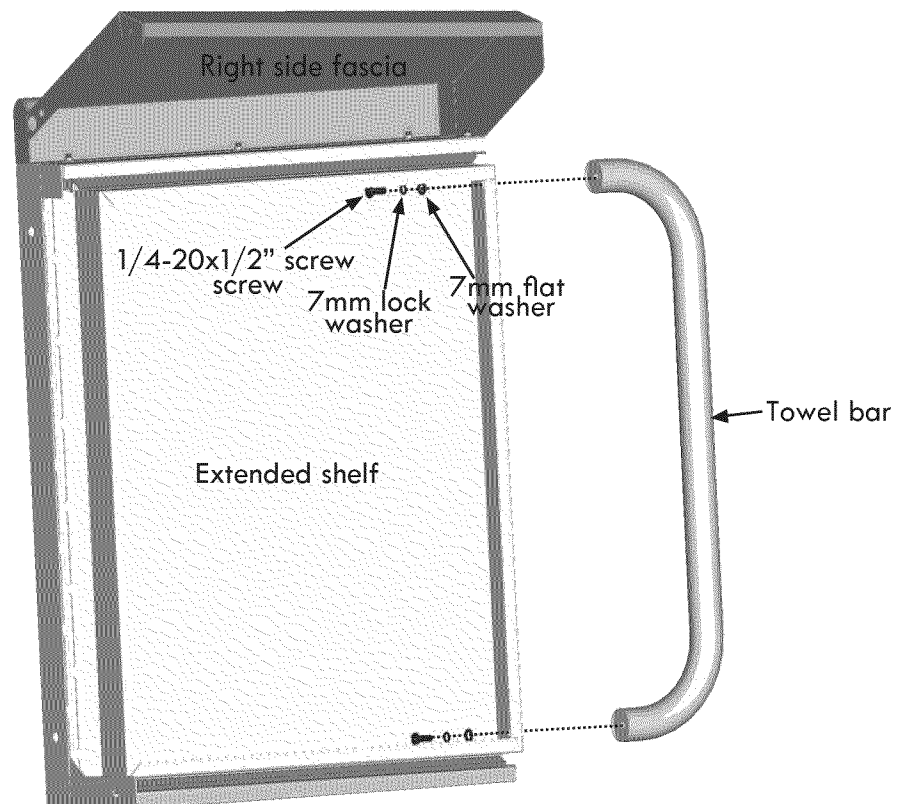

13

Hang right side shelf onto shelf brackets on right side of firebox, shown A. Pull extended shelf out halfway to create hand space to insert and tighten hardware. You may need an assistant to help you securely tighten shelf into place. Attach right side shelf using two 1/4-20x3/4" screws, 7mm flat washers, 7mm lock washers and 1/4" nuts, shown B/C. Attach front of shelf using two #8x3/8" self-tapping screws and large flat washers, shown C.

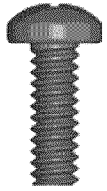

1/4-20x3/4" screw
Qty.2



7mm flat washer
Qty.2



7mm lock washer
Qty.2



1/4" nut
Qty.2



#8x3/8" self-tapping screw
Qty.2

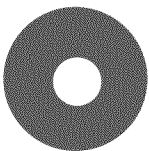

Large flat washer
Qty.2

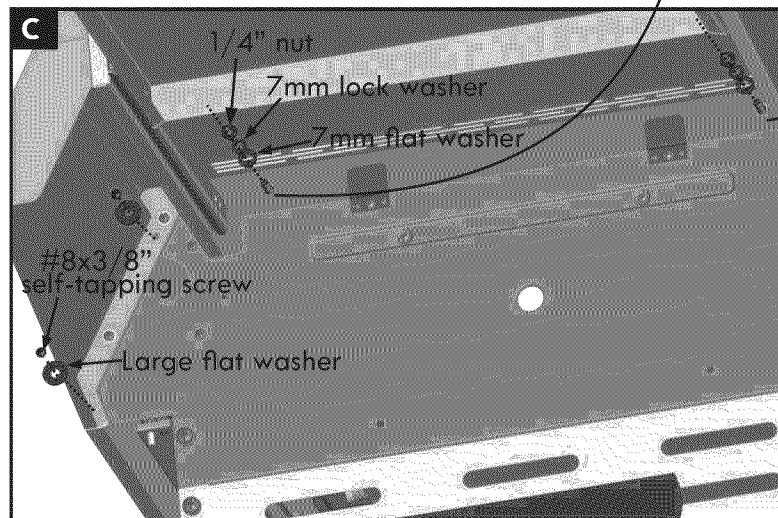
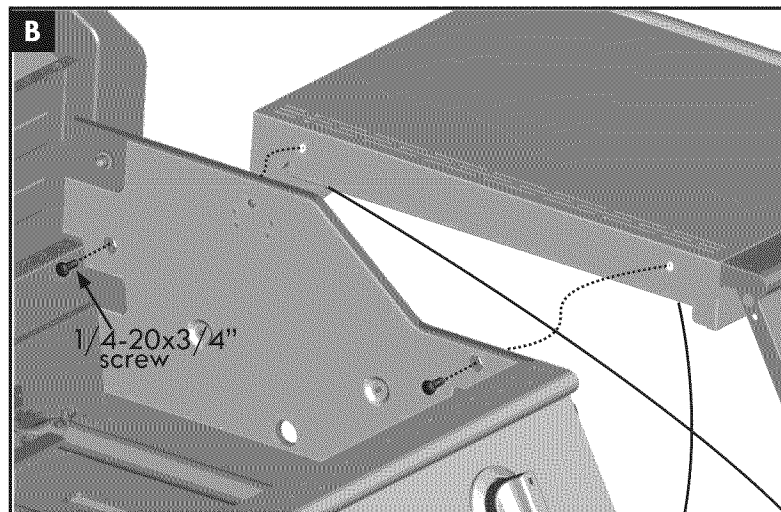
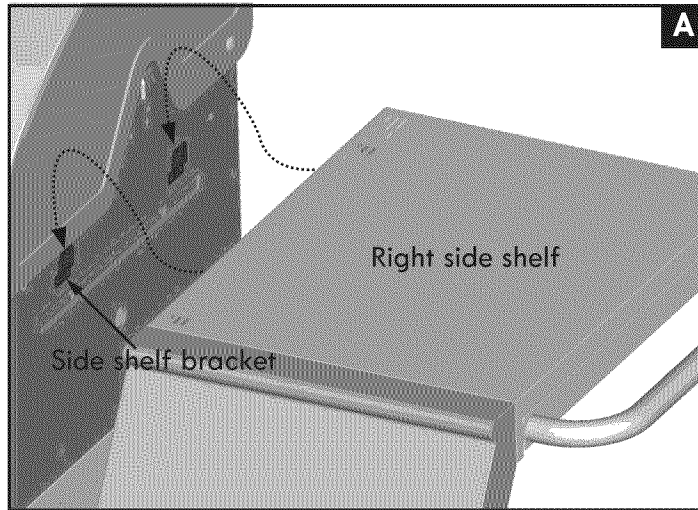

14

Hang sideburner shelf onto shelf brackets on left side of firebox, shown A.

Attach sideburner shelf using two 1/4-20x3/4" screws, 7mm flat washers, 7mm lock washers and 1/4" nuts, shown B/C. You may need an assistant to help you securely tighten shelf into place.

Attach front of shelf using two #8x3/8" self-tapping screws and large flat washers, shown C.

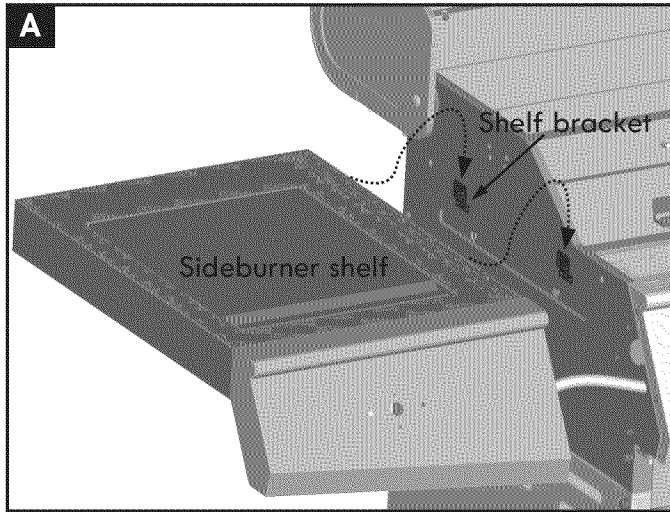

1/4-20x3/4" screw
Qty.2



7mm flat washer
Qty.2

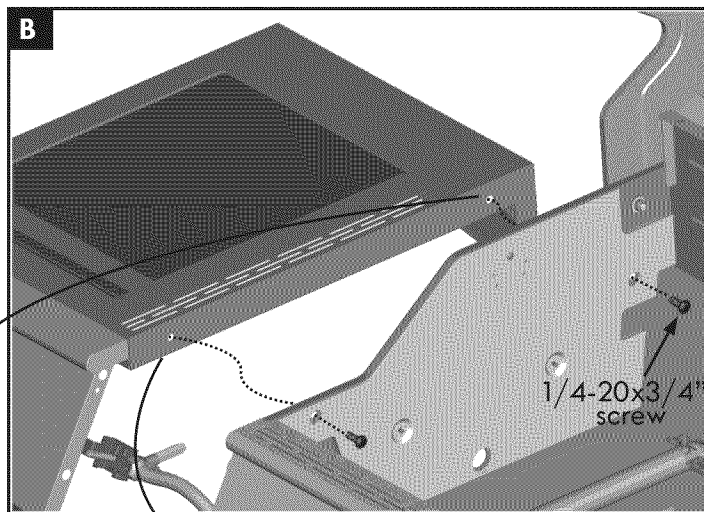

7mm lock washer
Qty.2



1/4" nut
Qty.2

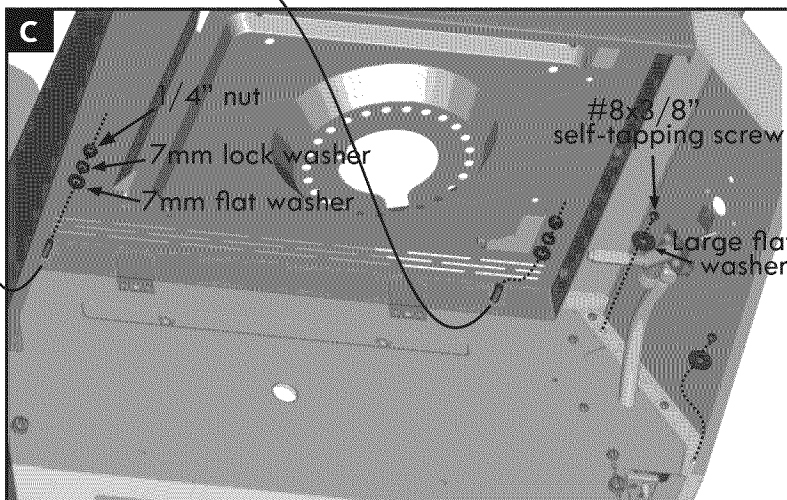

#8x3/8" self-tapping screw
Qty.2

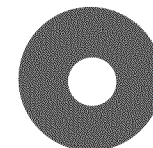

Large flat washer
Qty.2

15

First, remove the two screws and lock washers attached to the sideburner valve bracket. Position sideburner valve bracket beneath sideburner shelf fascia so that valve stem comes through larger center hole in fascia. Align the holes on valve bracket with left and right holes on fascia. Attach using lock washers and screws that were removed from bracket.

Next, place sideburner bezel over valve stem on front side of fascia. Align small holes on bezel with upper and lower holes on fascia, so that valve stem is centered in the large hole. Attach using two #8-32x3/8" screws and 4mm lock washers. Press sideburner control knob onto valve stem.

Note: Use left and right holes on fascia to attach valve bracket

Screws and Washers removed from valve bracket



#8-32x3/8" screw
Qty.2



4mm lock washer
Qty.2

Note: Use upper and lower holes on fascia to attach bezel

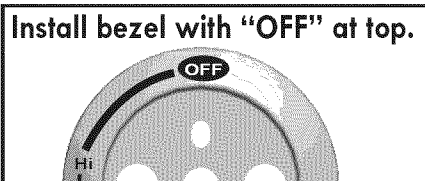
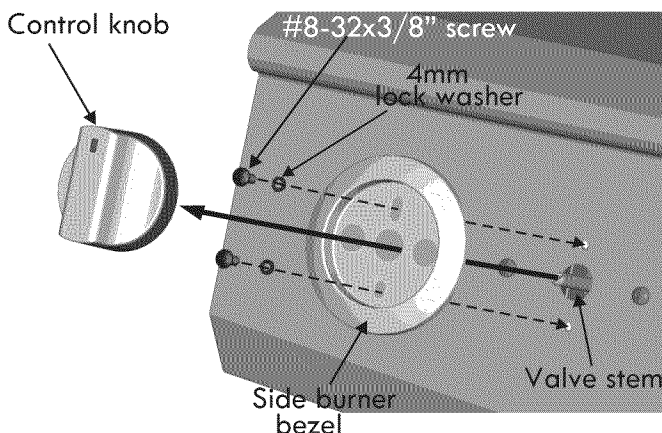
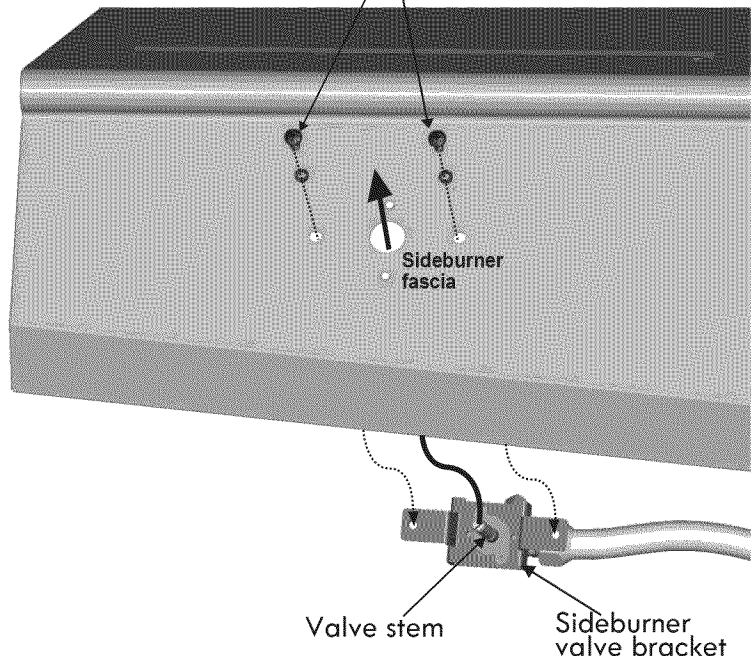

16

Insert sideburner tube through hole in bottom of sideburner shelf. The stud on bottom of burner fits into small hole at rear of sideburner drip pan, shown A.

Under sideburner shelf, secure burner to sideburner drip pan with one Wing nut. Untie sideburner ignitor wire which was tied to metal hose. Attach this wire to electrode. Make sure burner tube engages sideburner valve, shown B.



Wing nut
Qty.1

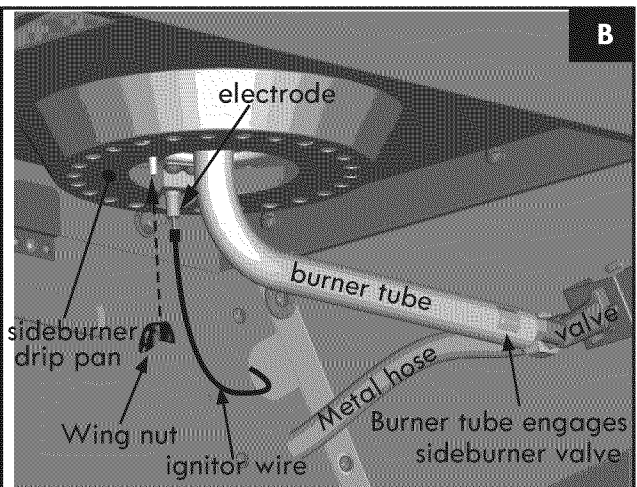
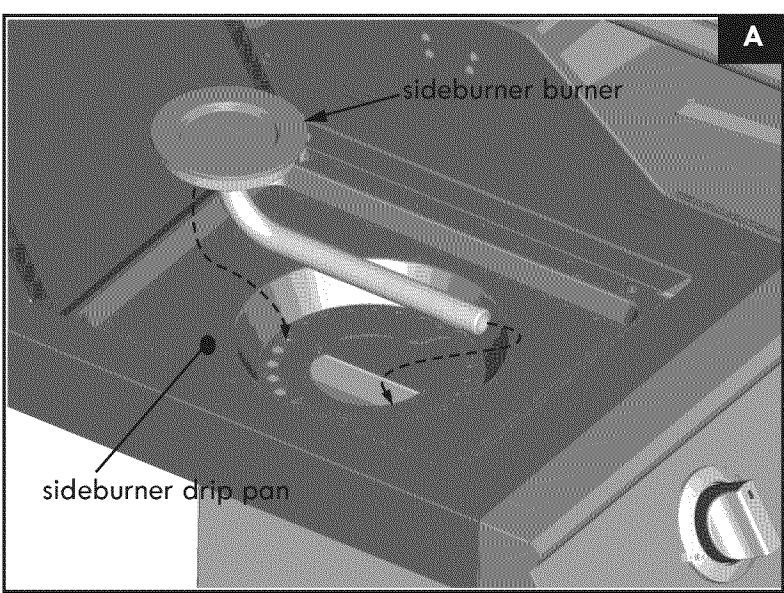

17 On each side of grill head, secure rear side shelf to upper back panel using one 1/4-20x1 1/2" screw, 7mm lock washer and 7mm flat washer.

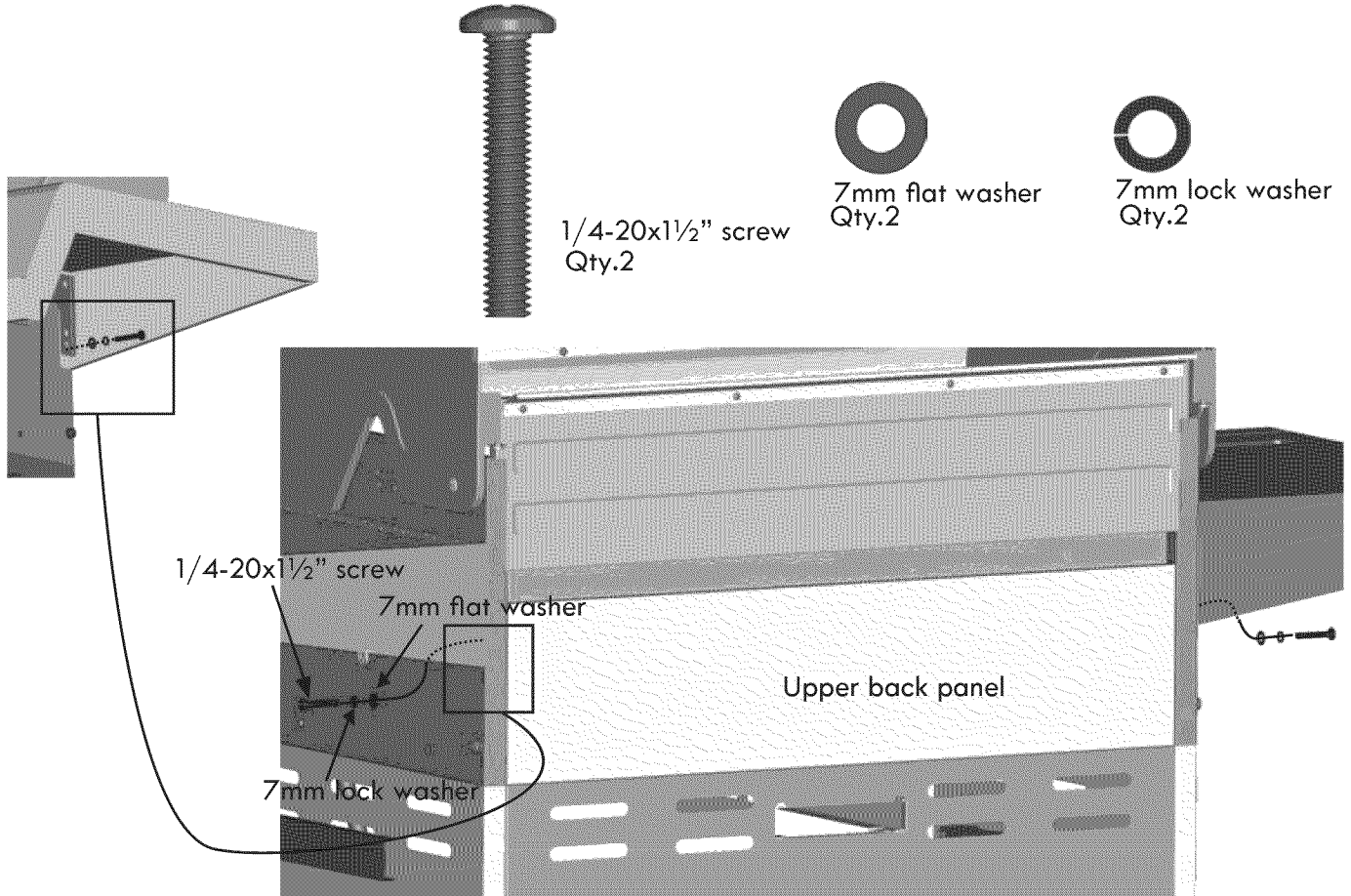

18 Place sideburner cooking grate onto sideburner shelf.

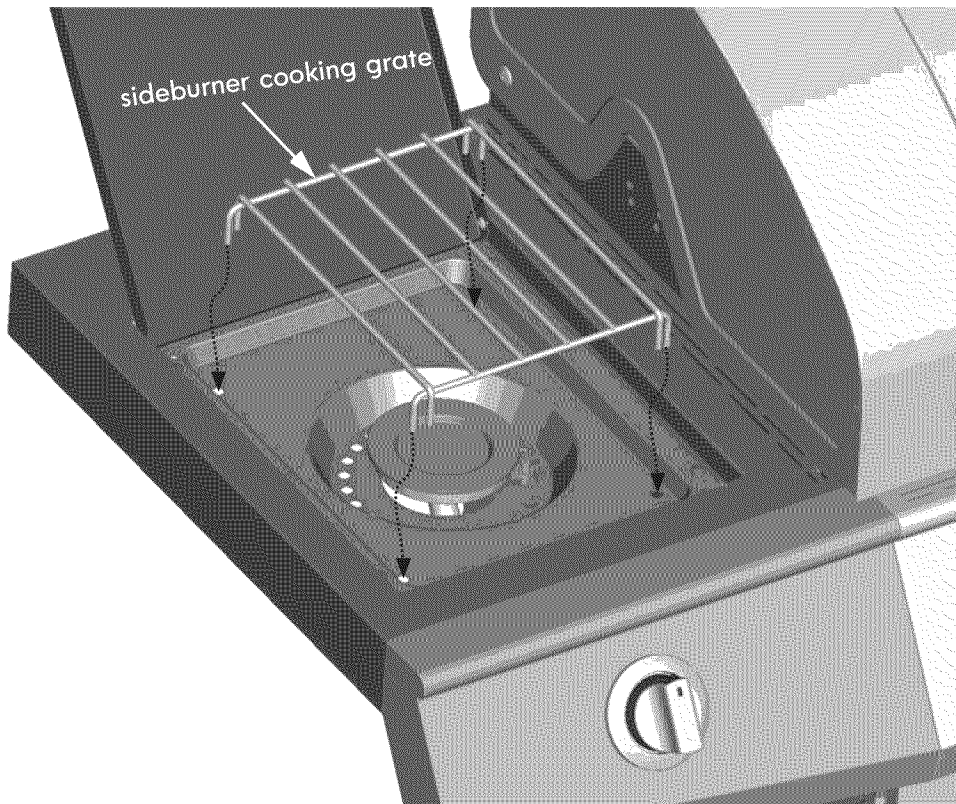

- 19** Insert the pin on bottom of right door into hole in bottom shelf. Press upper hinge pin in front brace, align hinge hole on top of the door, and release hinge pin into the door. Repeat for left door assembly.

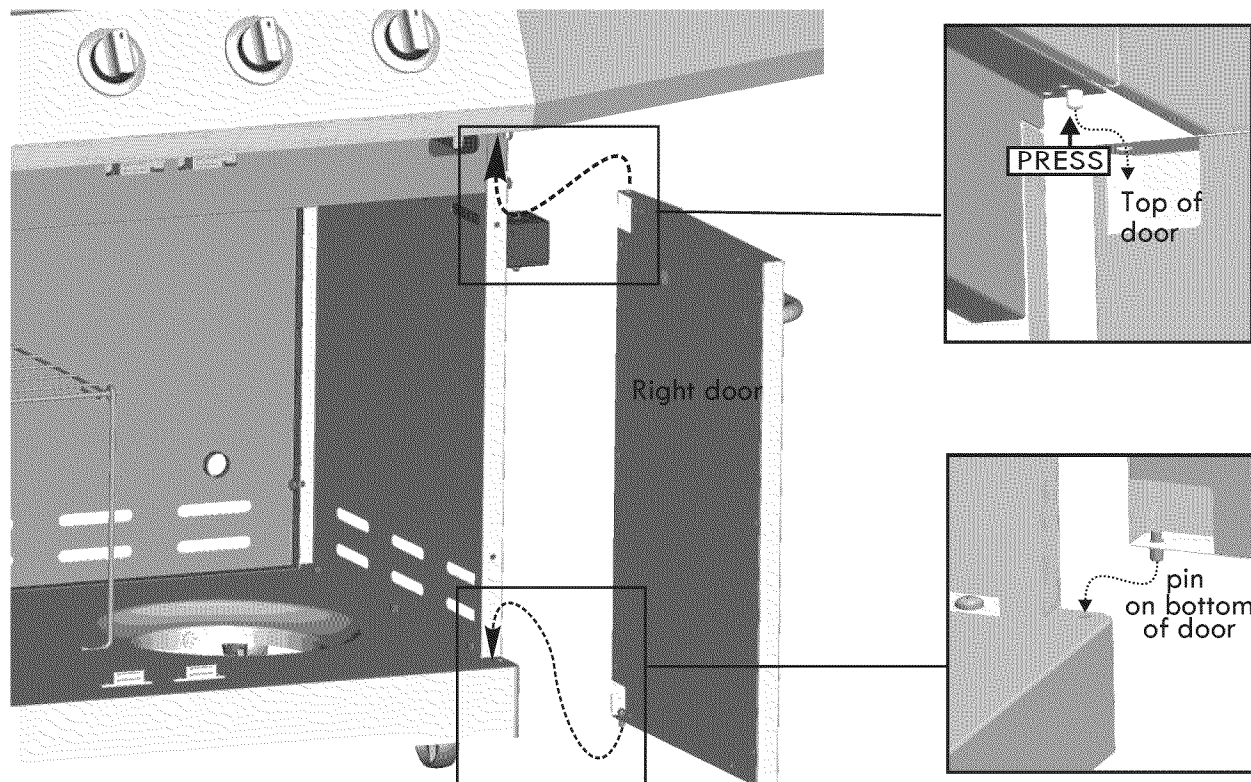

- 20** Install heat diffusers by sliding one end of each heat diffuser into slots at front of firebox and resting opposite end on pins at back of firebox.

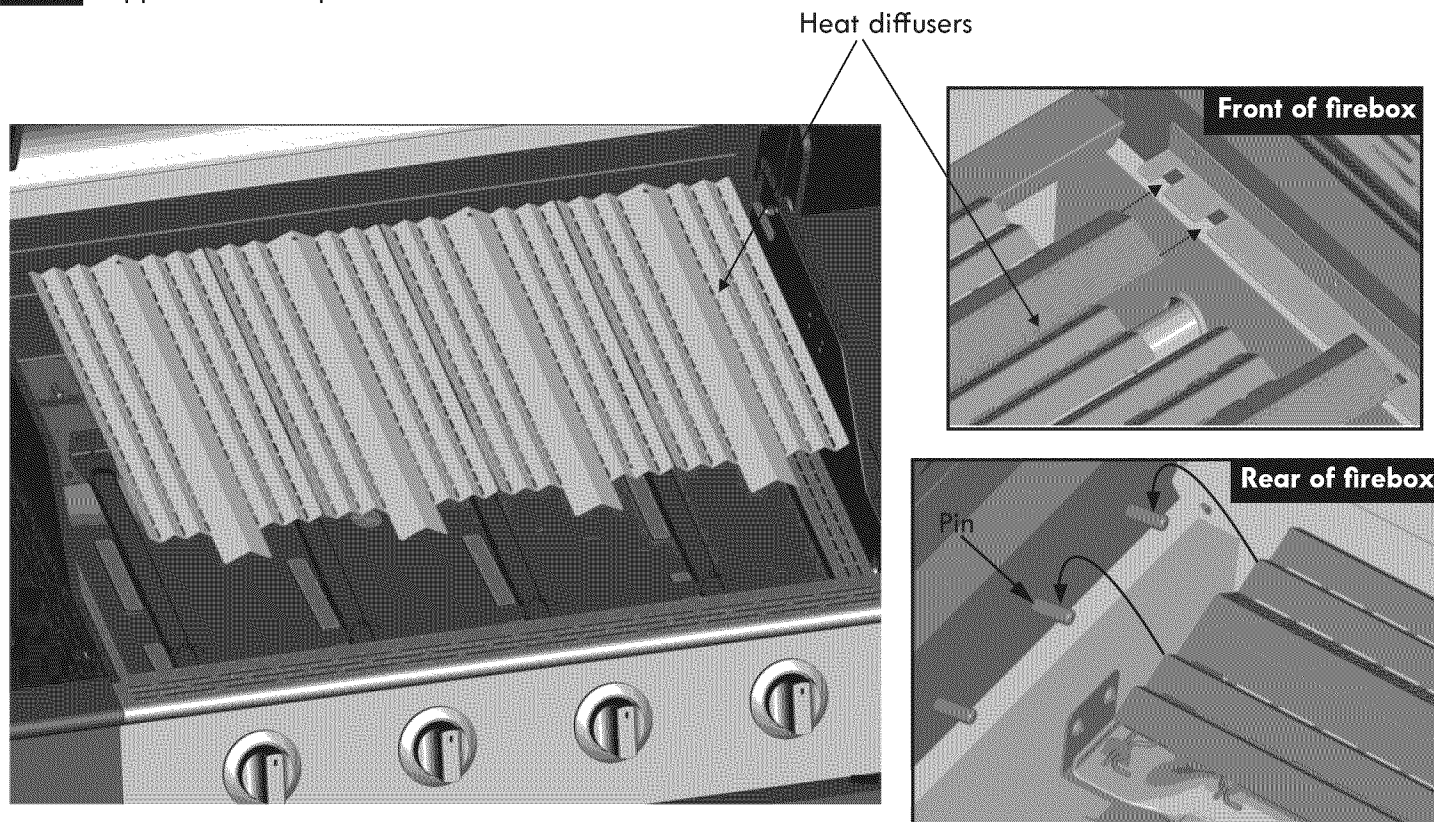

21

Place cooking grates onto the firebox as shown. To obtain sear marks in cooked meat, be sure to insert grates so that side with four corner feet faces down. Insert the two wire ends at rear of warming rack into holes in back of fire box. Front wires of warming rack rest on sides of firebox.

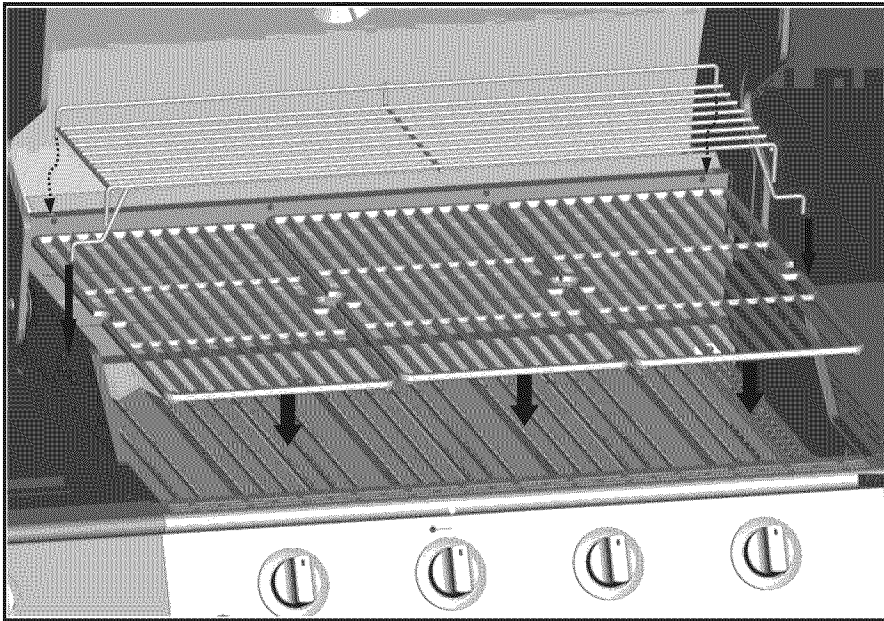

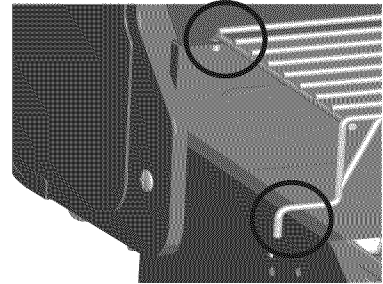

Assembled
warming rack



22

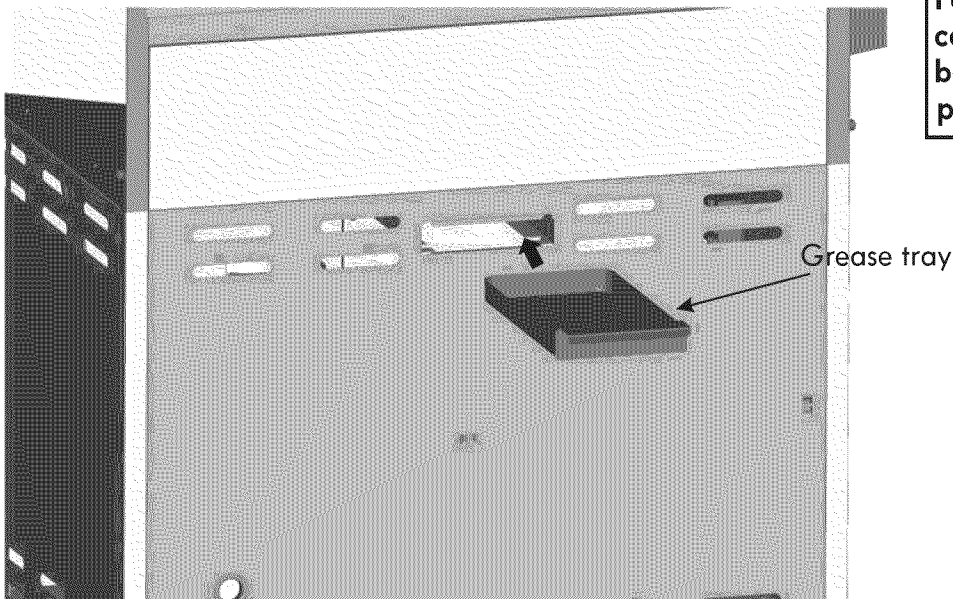

On back of grill, slide grease tray into opening in upper back panel.



	CAUTION	
<p>Failure to install grease tray will cause hot grease to drip from bottom of grill with risk of fire or property damage.</p>		

23

LP CYLINDER IS SOLD SEPARATELY. Fill and leak check the cylinder before attaching to grill and regulator (see Use & Care section). Once cylinder has been filled and checked for leaks, place cylinder into hole in bottom shelf. Make sure cylinder valve is facing front of grill. Secure cylinder with cylinder screw under bottom shelf. See Use & Care section of this manual to perform the “Burner Flame Check” and for important safety instructions before using.

	CAUTION	
<p>Cylinder valve must face to front of cart once tank is attached. Failure to install cylinder correctly may allow gas hose to be damaged in operation, resulting in the risk of fire.</p>		

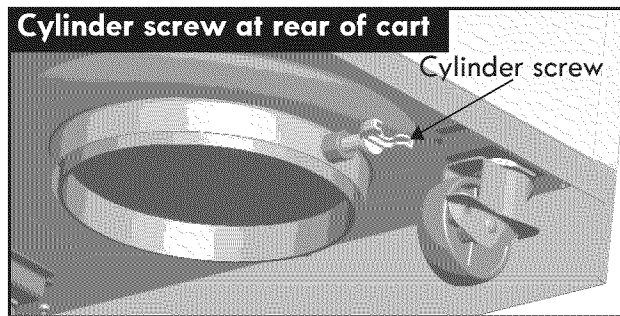

Always keep LP cylinders in upright position during use, transport, and storage.

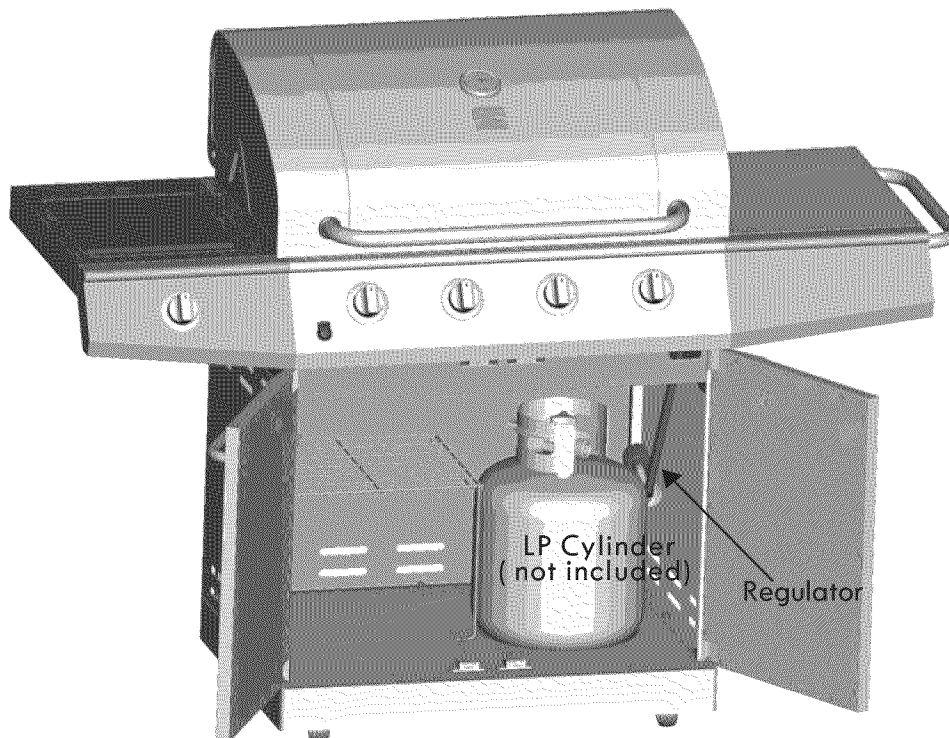

Steamer Tray Use

1. Remove one grate from grill and replace with steamer tray accessory.

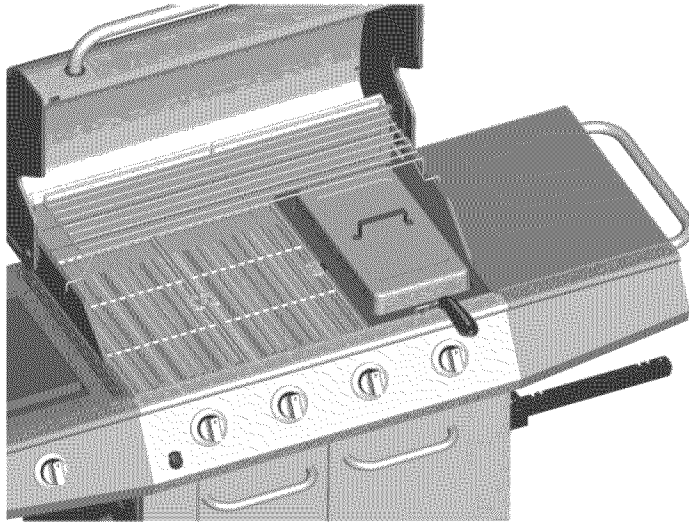

2. Do not fill water above water fill line.

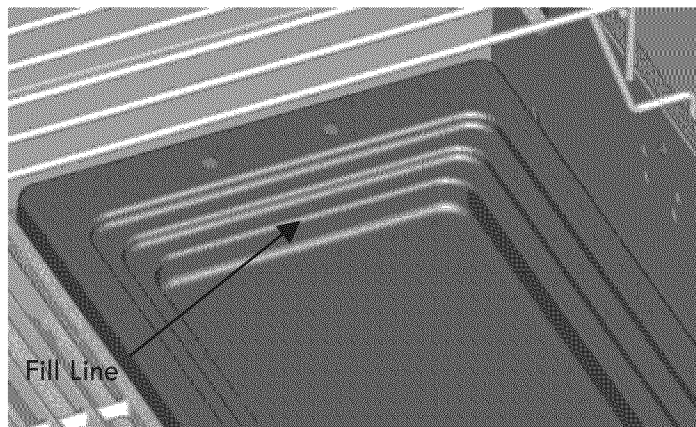

3. Always use Steamer Handle Tool to move Steamer Basket or Steamer Cover when grill is hot. Never move the Steamer Water Tray when grill is hot.

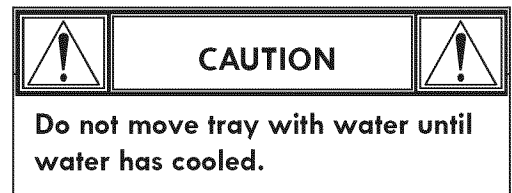
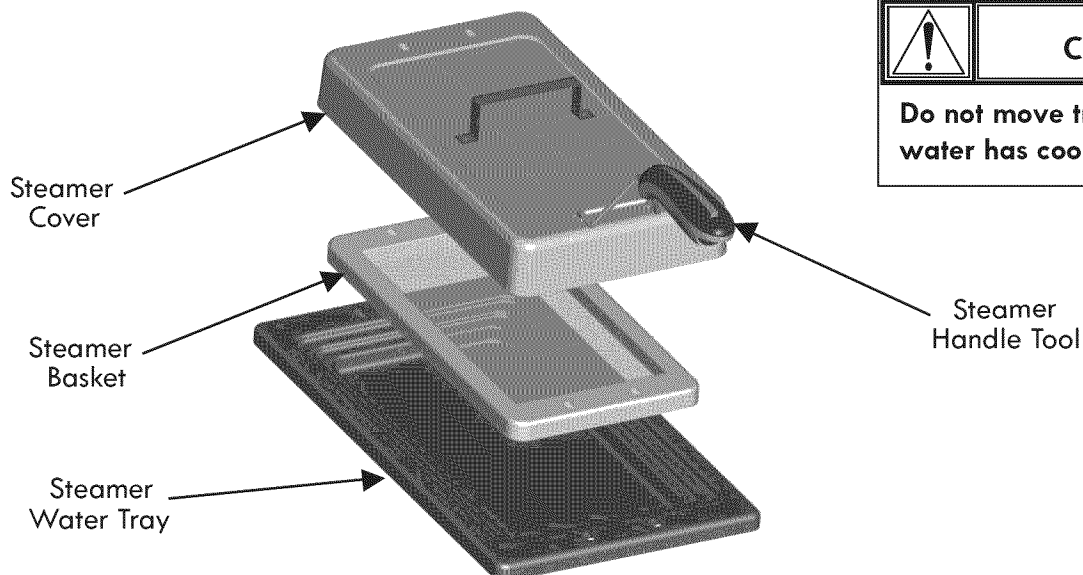

EMERGENCIES: If a gas leak cannot be stopped, or a fire occurs due to gas leakage, call the fire department.

Emergencies	Possible Cause	Prevention/Solution
Gas leaking from cracked/cut/burned hose.	<ul style="list-style-type: none"> • Damaged hose. 	<ul style="list-style-type: none"> • Turn off gas at LP cylinder or at source on natural gas systems. If the hose is cracked or cut but not burned, simply replace valve/hose/ regulator. If the hose is burned, the cause could be other than a faulty valve/hose/regulator. Discontinue use of grill until a plumber or gas technician has investigated and corrected the problem. • Replace LP cylinder.
Gas leaking from LP cylinder.	<ul style="list-style-type: none"> • Mechanical failure due to rusting or mishandling. 	<ul style="list-style-type: none"> • Turn off LP cylinder valve. Return LP cylinder to gas supplier.
Gas leaking from LP cylinder valve.	<ul style="list-style-type: none"> • Failure of cylinder valve from mishandling or mechanical failure. 	<ul style="list-style-type: none"> • Turn off LP cylinder valve. Remove regulator from cylinder and visually inspect rubber seal for damage. See LP Cylinder Leak Test and Connecting Regulator to the LP Cylinder.
Gas leaking between LP cylinder and regulator connection.	<ul style="list-style-type: none"> • Improper installation, connection not tight, failure of rubber seal. 	<ul style="list-style-type: none"> • Turn off LP cylinder valve. Remove regulator from cylinder and visually inspect rubber seal for damage. See LP Cylinder Leak Test and Connecting Regulator to the LP Cylinder.
Fire coming through control panel.	<ul style="list-style-type: none"> • Fire in burner tube section of burner due to blockage. 	<ul style="list-style-type: none"> • Turn off control knobs and LP cylinder valve. Leave lid open to allow flames to die down. After fire is out and grill is cold, remove burner and inspect for spider nests or rust. See Spider Alert and Cleaning the Burner Assembly sections of this Use & Care Guide.
Grease fire or continuous excessive flames above cooking surface.	<ul style="list-style-type: none"> • Too much grease buildup in burner area. 	<ul style="list-style-type: none"> • Turn off control knobs and LP cylinder valve. Leave lid open to allow flames to die down. After cooling, clean food particles and excess grease from inside firebox area, grease tray, and other surfaces.

Troubleshooting

Problem	Possible Cause	Prevention/Solution
<p>Burner(s) will not light using ignitor. (See Electronic Ignition Troubleshooting also)</p> <p>Continued on next page.</p>	<p>GAS ISSUES:</p> <ul style="list-style-type: none"> • Trying to light wrong burner. • Burner not engaged with control valve. • Obstruction in burner. • No gas flow. • Vapor lock at coupling nut to LP cylinder. • Coupling nut and LP cylinder valve not fully connected. <p>ELECTRICAL ISSUES:</p> <ul style="list-style-type: none"> • Electrode cracked or broken; "sparks at crack." • Electrode tip not in proper position. • Wire and/or electrode covered with cooking residue. • Wires are loose or disconnected. • Wires are shorting (sparking) between ignitor and electrode. • Dead battery. 	<ul style="list-style-type: none"> • See instructions on control panel and in Use and Care section. • Make sure valves are positioned inside of burner tubes. • Ensure burner tubes are not obstructed with spider webs or other matter. See cleaning section of Use and Care. • Make sure LP cylinder is not empty. If LP cylinder is not empty, refer to "Sudden drop in gas flow." • Turn off knobs and disconnect coupling nut from LP cylinder. Reconnect and retry. • Turn the coupling nut approximately one-half to three-quarters additional turn until solid stop. Tighten by hand only - do not use tools. • Replace electrode(s). Main Burners: <ul style="list-style-type: none"> • Tip of electrode should be pointing toward gas port opening on burner. The distance should be 1/8" to 1/4". Adjust if necessary. Sideburner: <ul style="list-style-type: none"> • Tip of electrode should be pointing toward gas port opening on burner. the distance should be 1/8" to 3/16". Adjust if necessary. • Clean wire and/or electrode with rubbing alcohol and clean swab. • Reconnect wires or replace electrode/wire assembly. • Replace ignitor wire/electrode assembly. • Replace with a new AA-size alkaline battery.

Troubleshooting (continued)

Problem	Possible Cause	Prevention/Solution
Burner(s) will not light using ignitor. (See Electronic Ignition Troubleshooting also)	ELECTRONIC IGNITION: <ul style="list-style-type: none"> • No spark, no ignition noise. • No spark, some ignition noise. • Sparks, but not at electrode or at full strength. 	<ul style="list-style-type: none"> • See Section I of Electronic Ignition System. • See Section II of Electronic Ignition System. • See Section III of Electronic Ignition System.
Burner(s) will not match light.	<ul style="list-style-type: none"> • See "GAS ISSUES:" on previous page. • Match will not reach. • Improper method of match-lighting. 	<ul style="list-style-type: none"> • Use long-stem match (fireplace match). • See "Match-Lighting" section of Use and Care.
Sudden drop in gas flow or low flame.	<ul style="list-style-type: none"> • Out of gas. • Excess flow valve tripped. • Vapor lock at coupling nut/LP cylinder connection. 	<ul style="list-style-type: none"> • Check for gas in LP cylinder. • Turn off knobs, wait 30 seconds and light grill. If flames are still low, turn off knobs and LP cylinder valve. Disconnect regulator. Reconnect regulator and leak-test. Turn on LP cylinder valve, wait 30 seconds and then light grill. • Turn off knobs and LP cylinder valve. Disconnect coupling nut from cylinder. Reconnect and retry.
Flames blow out.	<ul style="list-style-type: none"> • High or gusting winds. • Low on LP gas. • Excess flow valve tripped. 	<ul style="list-style-type: none"> • Turn front of grill to face wind or increase flame height. • Refill LP cylinder. • Refer to "Sudden drop in gas flow" above.
Flare-up.	<ul style="list-style-type: none"> • Grease buildup. • Excessive fat in meat. • Excessive cooking temperature. 	<ul style="list-style-type: none"> • Clean burners and inside of grill/firebox. • Trim fat from meat before grilling. • Adjust (lower) temperature accordingly.
Persistent grease fire.	<ul style="list-style-type: none"> • Grease trapped by food buildup around burner system. 	<ul style="list-style-type: none"> • Turn knobs to OFF. Turn gas off at LP cylinder. Leave lid in position and let fire burn out. After grill cools, remove and clean all parts.
Flashback... (fire in burner tube(s)).	<ul style="list-style-type: none"> • Burner and/or burner tubes are blocked. 	<ul style="list-style-type: none"> • Turn knobs to OFF. Clean burner and/or burner tubes. See burner cleaning section of Use and Care.
Unable to fill LP cylinder.	<ul style="list-style-type: none"> • Some dealers have older fill nozzles with worn threads. 	<ul style="list-style-type: none"> • The worn nozzles don't have enough "bite" to engage the valve. Try a second LP dealer.
One burner does not light from other burner(s).	<ul style="list-style-type: none"> • Grease buildup or food particles in end(s) of carryover tube(s). 	<ul style="list-style-type: none"> • Clean carry-over tube(s) with wire brush.

Troubleshooting - Electronic Ignition

Problem (Ignition)	Possible Cause	Check Procedure	Prevention/Solution
<p>SECTION I</p> <p>No sparks appear at any electrodes when Electronic Ignition Button is pressed; no noise can be heard from spark module.</p>	<ul style="list-style-type: none"> Battery not installed properly. Dead battery. Button assembly not installed properly. Faulty spark module. 	<ul style="list-style-type: none"> Check battery orientation. Has battery been used previously? Check to insure threads are properly engaged. Button should travel up and down without binding. If no sparks are generated with new battery and good wire connections, module is faulty. 	<ul style="list-style-type: none"> Install battery (make sure that “+” and “-” connectors are oriented correctly, with “+” end up and “-” end down.) Replace battery with new AA-size alkaline battery. Unscrew button cap assembly and reinstall, making sure threads are aligned and engaged fully. Replace spark module assembly.
<p>SECTION II</p> <p>No sparks appear at any electrodes when Electronic Ignition Button is pressed; noise can be heard from spark module.</p>	<ul style="list-style-type: none"> Output lead connections not connected. 	<ul style="list-style-type: none"> Are output connections on and tight? 	<ul style="list-style-type: none"> Remove and reconnect all output connections at module and electrodes.
<p>SECTION III</p> <p>Sparks are present but not at all electrodes and/or not at full strength</p>	<ul style="list-style-type: none"> Output lead connections not connected. Arcing to grill away from burner(s). Weak battery. Electrodes are wet. Electrodes cracked or broken “sparks at crack”. 	<ul style="list-style-type: none"> Are output connections on and tight? If possible, observe grill in dark location. Operate ignition system and look for arcing between output wires and grill frame. All sparks present but weak or at slow rate. Has moisture accumulated on electrode and/or in burner ports? Inspect electrodes for cracks. 	<ul style="list-style-type: none"> Remove and reconnect all output connections at module and electrodes. If sparks are observed other than from burner(s), wire insulation may be damaged. Replace wires. Replace battery with a new AA-size alkaline battery. Use paper towel to remove moisture. Replace cracked or broken electrodes.

Get it fixed, at your home or ours!

Your Home

For troubleshooting, product manuals and expert advice:



www.managemylife.com

For repair – **in your home** – of **all** major brand appliances, lawn and garden equipment, or heating and cooling systems, **no matter who made it, no matter who sold it!**

For the replacement parts, accessories and owner's manuals that you need to do-it-yourself.

For Sears professional installation of home appliances and items like garage door openers and water heaters.

1-800-4-MY-HOME[®] (1-800-469-4663)

Call anytime, day or night (U.S.A. and Canada)

www.sears.com

www.sears.ca

Our Home

For repair of carry-in items like vacuums, lawn equipment, and electronics, call anytime for the location of your nearest

Sears Parts & Repair Service Center

1-800-488-1222 (U.S.A.)

www.sears.com

1-800-469-4663 (Canada)

www.sears.ca

To purchase a protection agreement on a product serviced by Sears:

1-800-827-6655 (U.S.A.)

1-800-361-6665 (Canada)

Para pedir servicio de reparación a domicilio, y para ordenar piezas:

1-888-SU-HOGAR[®]

(1-888-784-6427)

www.sears.com

Au Canada pour service en français:

1-800-LE-FOYER^{MC}

(1-800-533-6937)

www.sears.ca

The Sears logo, featuring the word "Sears" in a large, stylized, serif font with a shadow effect.