



**Count on it.**

**Operator's Manual**

**TimeCutter® Z4200, Z4220, and Z5000 Riding Mowers**

Model No. 74360—Serial No. 290000001 and Up

Model No. 74363—Serial No. 290000001 and Up

Model No. 74370—Serial No. 290000001 and Up



## Warning

### CALIFORNIA Proposition 65 Warning

The engine exhaust from this product contains chemicals known to the State of California to cause cancer, birth defects, or other reproductive harm.

**Important:** This engine is not equipped with a spark arrester muffler. It is a violation of California Public Resource Code Section 4442 to use or operate the engine on any forest-covered, brush-covered, or grass-covered land. Other states or federal areas may have similar laws.

This spark ignition system complies with Canadian ICES-002.

The enclosed *Engine Owner's Manual* is supplied for information regarding the US Environmental Protection Agency (EPA) and the California Emission Control Regulation of emission systems, maintenance, and warranty. Replacements may be ordered through the engine manufacturer.

For models with stated engine horsepower, the gross horsepower of the engine was laboratory rated by the engine manufacturer in accordance with SAE J1940. As configured to meet safety, emission, and operating requirements, the actual engine horsepower on this class of lawn mower will be significantly lower.

## Introduction

Read this information carefully to learn how to operate and maintain your product properly and to avoid injury and product damage. You are responsible for operating the product properly and safely.

You may contact Toro directly at [www.Toro.com](http://www.Toro.com) for product and accessory information, help finding a dealer, or to register your product.

Whenever you need service, genuine Toro parts, or additional information, contact an Authorized Service Dealer or Toro Customer Service and have the model and serial numbers of your product ready. Figure 1 identifies the location of the model and serial numbers on the product. Write the numbers in the space provided.

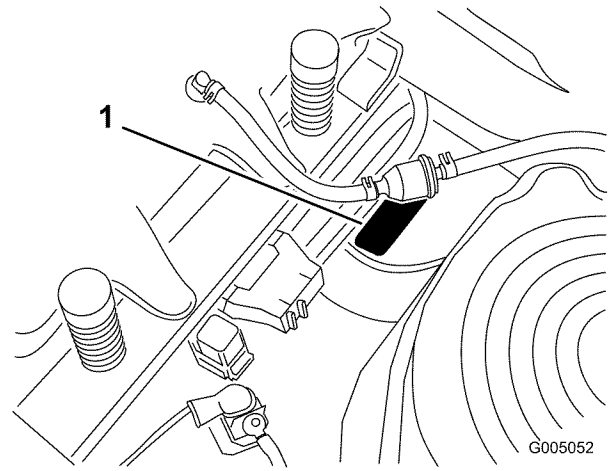

Figure 1

Under the seat

1. Model and serial number plate

Write the product model and serial numbers in the space below:

Model No. _____
Serial No. _____

This manual identifies potential hazards and has safety messages identified by the safety alert symbol (Figure 2), which signals a hazard that may cause serious injury or death if you do not follow the recommended precautions.



Figure 2

1. Safety alert symbol.

This manual uses two other words to highlight information. **Important** calls attention to special mechanical information and **Note** emphasizes general information worthy of special attention.

## Contents

Introduction.....	2
Safety .....	3
Safe Operating Practices .....	3
Toro Riding Mower Safety .....	5
Slope Chart .....	7
Safety and Instructional Decals .....	8
Product Overview .....	12

# Safety

**This machine meets or exceeds the B71.1-2003 specifications of the American National Standards Institute, in effect at the time of production. However, improper use or maintenance by the operator or owner can result in injury. To reduce the potential for injury, comply with these safety instructions and always pay attention to the safety alert symbol, which means CAUTION, WARNING, or DANGER-"personal safety instruction." Failure to comply with the instruction may result in personal injury or death.**

## Safe Operating Practices

The following instructions are from ANSI standard B71.1-2003.

This product is capable of amputating hands and feet and throwing objects. Always follow all safety instructions to avoid serious injury or death.

## General Operation

- Read, understand, and follow all instructions in the operator's manual and on the machine before starting.
- Do not place hands or feet near rotating parts or under the machine. Keep clear of the discharge opening at all times.
- Allow only responsible adults who are familiar with the instructions to operate the machine.
- Clear the area of objects such as rocks, toys, wire, etc., which could be picked up and thrown by the blade.
- Be sure the area is clear of other people before mowing. Stop the machine if anyone enters the area.
- Never carry passengers.
- Do not mow in reverse unless absolutely necessary. Always look down and behind before and while backing up.
- Be aware of the mower discharge direction and do not point it at anyone. Avoid discharging material against a wall or obstruction. Material may ricochet back toward the operator. Stop the blade(s) when crossing gravel surfaces.
- Do not operate the machine without deflector, discharge cover or entire grass collection system in place and working.
- Be alert, slow down and use caution when making turns. Look behind and to the side before changing directions.

Controls.....	13
Operation.....	14
Think Safety First.....	14
Recommended Gasoline.....	14
Checking the Engine Oil Level.....	16
Starting the Engine.....	16
Operating the Blades.....	17
Stopping the Engine.....	18
The Safety Interlock System.....	18
Driving Forward or Backward.....	19
Stopping the Machine.....	20
Adjusting the Height of Cut.....	20
Positioning the Seat.....	20
Adjusting the Motion Control Levers.....	20
Pushing the Machine by Hand.....	21
Grass Deflector.....	22
Operating Tips.....	22
Maintenance.....	24
Recommended Maintenance Schedule(s).....	24
Pre-maintenance Procedures.....	25
Raising the Seat.....	25
Accessing the Battery.....	25
Lubrication.....	25
Greasing the Bearings.....	25
Engine Maintenance.....	26
Servicing the Air Cleaner.....	26
Servicing the Engine Oil.....	27
Servicing the Spark Plug.....	29
Cleaning the Blower Housing.....	29
Fuel System Maintenance.....	30
Replacing the Fuel Filter.....	30
Electrical System Maintenance.....	31
Charging the Battery.....	31
Servicing the Fuses.....	32
Drive System Maintenance.....	33
Checking the Tire Pressure.....	33
Mower Maintenance.....	34
Servicing the Cutting Blades.....	34
Leveling the Mower Deck.....	36
Removing the Mower.....	38
Mower Belt Maintenance.....	39
Installing the Mower.....	40
Replacing the Grass Deflector.....	40
Cleaning.....	41
Washing the Underside of the Mower.....	41
Storage.....	42
Cleaning and Storage.....	42
Troubleshooting.....	44
Schematics.....	46

- Never leave a running machine unattended. Always turn off blades, set parking brake, stop engine, and remove key before dismounting.
- Turn off blades when not mowing. Stop the engine and wait for all parts to come to a complete stop before cleaning the machine, removing the grass catcher or unclogging the discharge chute.
- Operate the machine only in daylight or good artificial light.
- Do not operate the machine while under the influence of alcohol or drugs.
- Watch for traffic when operating near or crossing roadways.
- Use extra care when loading or unloading the machine into a trailer or truck.
- Always wear eye protection when operating the mower.
- Data indicates that operators, age 60 years and above, are involved in a large percentage of riding mower-related injuries. These operators should evaluate their ability to operate the riding mower safely enough to protect themselves and others from serious injury.
- Always follow the recommendations for wheel weights or counterweights.
- Avoid sudden starts when mowing uphill because the mower may tip backwards.
- Be aware that loss of traction may occur going downhill. Weight transfer to the front wheels may cause drive wheels to slip and cause loss of braking and steering.
- Always avoid sudden starting or stopping on a slope. If tires lose traction, disengage the blades and proceed slowly off the slope.
- Use extreme care with grass catchers or other attachments. These can change the stability of the machine and cause loss of control.
- Do not try to stabilize the machine by putting your foot on the ground.
- Do not mow near drop-offs, ditches, steep banks or water. Wheels dropping over edges can cause rollovers, which may result in serious injury, death or drowning.
- Use a walk behind mower and/or a hand trimmer near drop-offs, ditches, steep banks or water.

## Slope Operation

Slopes are a major factor related to loss of control and tip-over accidents, which can result in severe injury or death. Operation on all slopes requires extra caution. If you cannot back up the slope or if you feel uneasy on it, do not mow it.

- Do not mow slopes greater than 15 degrees.
- Watch for ditches, holes, rocks, dips, and rises that change the operating angle, as rough terrain could overturn the machine.
- Choose a low ground speed so you will not have to stop while operating on a slope.
- Do not mow slopes when grass is wet. Slippery conditions reduce traction and could cause sliding and loss of control.
- Always keep the wheel motors engaged when going down slopes.
- Reduce speed and use extreme caution on slopes.
- Do not make sudden turns or rapid speed changes.
- Remove or mark obstacles such as rocks, tree limbs, etc. from the mowing area. Tall grass can hide obstacles.

## Children

Tragic accidents can occur if the operator is not alert to the presence of children. Children are often attracted to the machine and the mowing activity. Never assume that children will remain where you last saw them.

- Keep children out of the mowing area and under the watchful care of another responsible adult, not the operator.
- Be alert and turn the machine off if children enter the area.
- Before and while backing or changing direction, look behind, down, and side-to-side for small children.
- Never carry children, even with the blades off. They may fall off and be seriously injured or interfere with safe machine operation.
- Children who have been given rides in the past may suddenly appear in the mowing area for another ride and be run over or backed over by the mower.
- Never allow children to operate the machine.
- Use extra care when approaching blind corners, shrubs, trees, the end of a fence or other objects that may obscure vision.

## Towing

A hitch kit is available for this machine and can be obtained by contacting an Authorized Toro Dealer. Do not tow without first installing this manufacturer

approved hitch. The following guidelines apply when towing with the approved hitch kit installed.

- Tow only with a machine that has a hitch designed for towing. Do not attach towed equipment except at the hitch point.
- Follow the manufacturer's recommendation for weight limits for towed equipment and towing on slopes.
- Never allow children or others in or on towed equipment.
- On slopes, the weight of the towed equipment may cause loss of traction and loss of control.
- Travel slowly and allow extra distance to stop.

## Service

### Safe Handling of Gasoline:

To avoid personal injury or property damage, use extra care when handling gasoline and other fuels. They are flammable and the vapors are explosive.

- Extinguish all cigarettes, cigars, pipes and other sources of ignition.
- Use only an approved container.
- Never remove the gas cap or add fuel when the engine is running. Allow the engine to cool before refueling.
- Never refuel the machine indoors.
- Never store the machine or fuel container inside where there is an open flame, such as near a water heater or furnace.
- Never fill containers inside a vehicle or on a truck or trailer with a plastic liner. Always place containers on the ground away from your vehicle before filling.
- Remove gas-powered equipment from the truck or trailer and refuel it on the ground. If this is not possible, then refuel such equipment with a portable container, rather than from a gasoline dispenser nozzle.
- Keep the nozzle in contact with the rim of the fuel tank or container opening at all times until the fueling is complete. Do not use a nozzle lock-open device.
- If fuel is spilled on clothing, change clothing immediately.
- Never overfill the fuel tank. Replace gas cap and tighten securely.

### General Service:

- Never operate a machine inside a closed area. Engine exhaust contains carbon monoxide, which is an odorless, deadly poison that can kill you.

- Keep nuts and bolts tight, especially the blade attachment bolts. Keep equipment in good condition.
- Never tamper with safety devices. Check their proper operation regularly.
- Keep the machine free of grass, leaves, or other debris build-up. Clean up oil or fuel spillage fuel soaked debris. Allow the machine to cool before storing.
- Stop and inspect the equipment if you strike an object. Repair, if necessary, before restarting.
- Never make any adjustments or repairs with the engine running.
- Grass catcher components are subject to wear, damage and deterioration, which could expose moving parts or allow objects to be thrown. Frequently check components and replace with manufacturers' recommended parts, when necessary.
- Mower blades are sharp and can cut. Wrap the blade(s) or wear gloves, and use extra caution when servicing them.
- Check for proper brake operation frequently. Adjust and service as required.
- Maintain or replace safety and instruction decals as necessary.
- Use only genuine Toro replacement parts to ensure that original standards are maintained.

## Toro Riding Mower Safety

The following list contains safety information specific to Toro products or other safety information that you must know that is not included in the ANSI standards.

- Stop the engine, disconnect spark plug wire(s) and remove key before performing any service, repairs, maintenance or adjustments.
- Keep hands, feet, hair, and loose clothing away from attachment discharge area, underside of mower and any moving parts while engine is running.
- Do not touch equipment or attachment parts which may be hot from operation. Allow to cool before attempting to maintain, adjust or service.
- Battery acid is poisonous and can cause burns. Avoid contact with skin, eyes, and clothing. Protect your face, eyes, and clothing when working with a battery.
- Battery gases can explode. Keep cigarettes, sparks and flames away from battery.

- Use only Toro approved attachments. Warranty may be voided if used with unapproved attachments.
- If loading the machine onto a trailer or truck, use a single, full-width ramp only. The ramp angle should not exceed 15 degrees.

**Note:** Determine the left and right sides of the machine from the normal operating position.

# Slope Chart

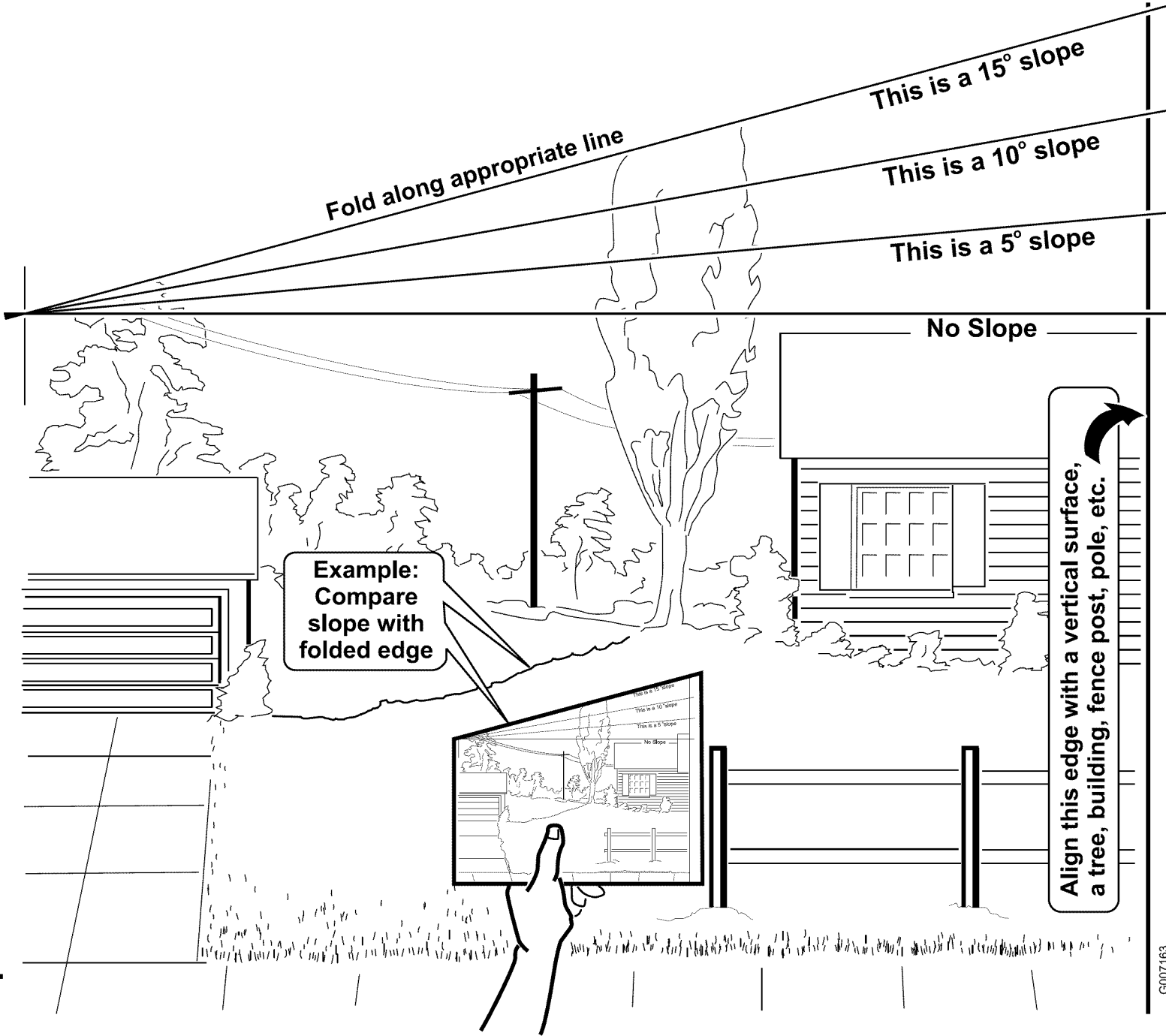

# Safety and Instructional Decals



Safety decals and instructions are easily visible to the operator and are located near any area of potential danger. Replace any decal that is damaged or lost.

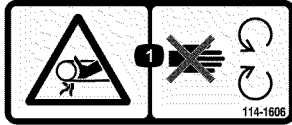

114-1606

1. Entanglement hazard, belt—keep all guards in place.

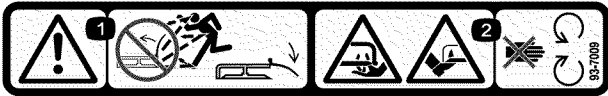

93-7009

1. Warning—don't operate the mower with the deflector up or removed; keep the deflector in place.
2. Cutting/dismemberment hazard of hand or foot, mower blade—stay away from moving parts.



Manufacturer's Mark

1. Indicates the blade is identified as a part from the original machine manufacturer.

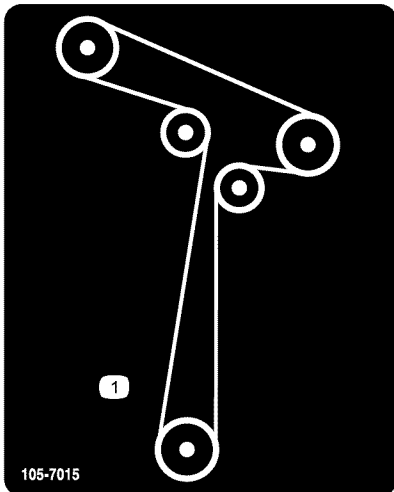

105-7015

105-7015

For Models with 42 Inch Decks

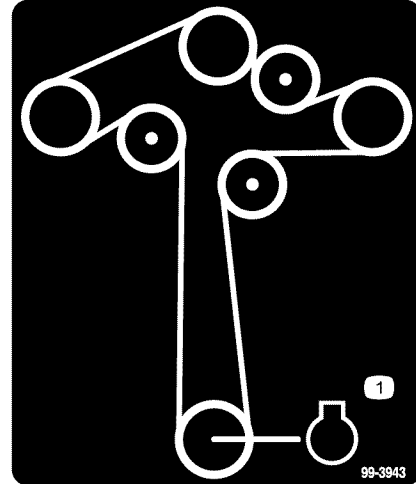

99-3943

99-3943

For Models with 50 Inch Decks

1. Engine

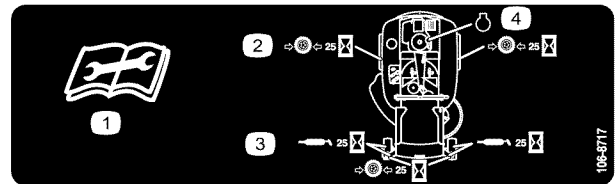

106-8717

1. Read the instructions before servicing or performing maintenance.
2. Check tire pressure every 25 operating hours.
3. Grease every 25 operating hours.
4. Engine

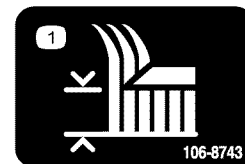

106-8743

106-8743

1. Height of cut



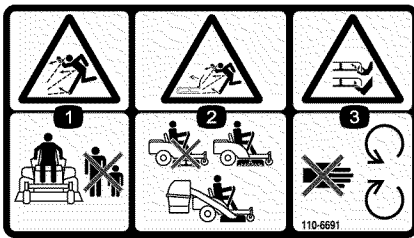

110-6691

1. Thrown object hazard—keep bystanders a safe distance from the machine.
2. Thrown object hazard, mower—do not operate the without deflector, discharge cover or grass collection system in place.
3. Cutting/dismemberment of hand or foot—stay away from moving parts.

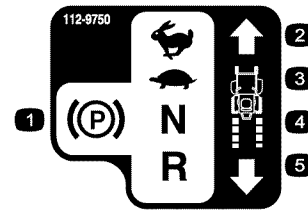

112-9750

1. Parking position
2. Fast
3. Slow
4. Neutral
5. Reverse

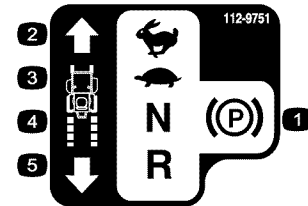

112-9751

1. Parking position
2. Fast
3. Slow
4. Neutral
5. Reverse

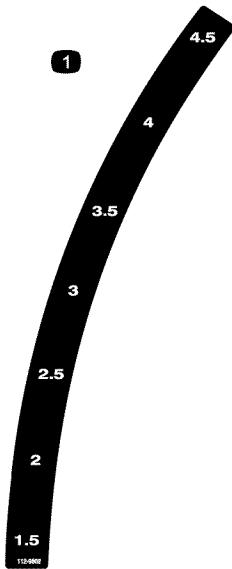

112-9802

1. Height-of-cut

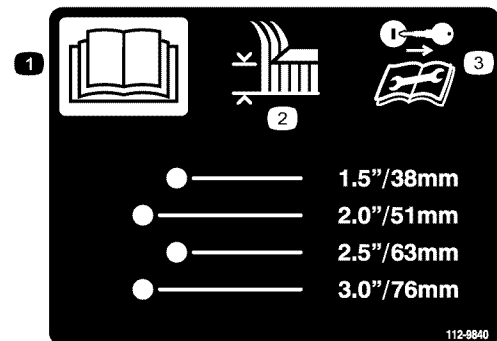

112-9840

For Models with 50 Inch Decks

1. Read the *Operator's Manual*.
2. Height of cut
3. Remove the ignition key and read the instructions before servicing or performing maintenance.

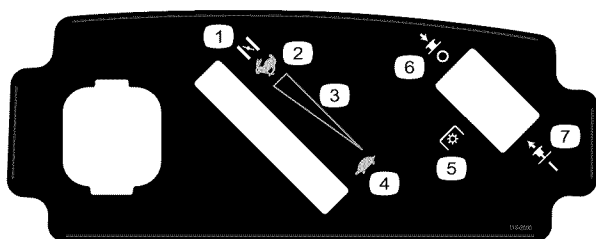

115-2500

1. Choke
2. Fast
3. Continuous variable setting
4. Slow
5. Power take-off (PTO), Blade control switch on some models
6. Blade control switch—Off
7. Blade control switch—On

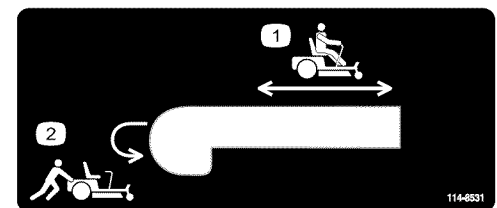

114-8531

1. Bypass lever position for operating the machine
2. Bypass lever position for pushing the machine

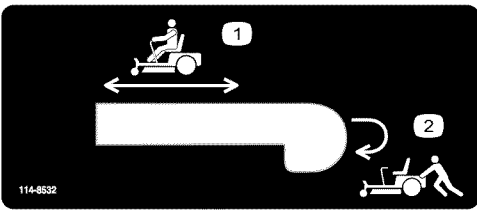

114-8532

1. Bypass lever position for operating the machine
2. Bypass lever position for pushing the machine

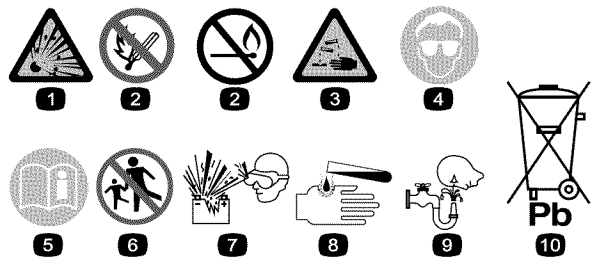

**Battery Symbols**

Some or all of these symbols are on your battery

- |  |  |
|--|--|
| 1. Explosion hazard                    | 6. Keep bystanders a safe distance from the battery.                           |
| 2. No fire, open flame, or smoking.    | 7. Wear eye protection; explosive gases can cause blindness and other injuries |
| 3. Caustic liquid/chemical burn hazard | 8. Battery acid can cause blindness or severe burns.                           |
| 4. Wear eye protection                 | 9. Flush eyes immediately with water and get medical help fast.                |
| 5. Read the <i>Operator's Manual</i> . | 10. Contains lead; do not discard.   |

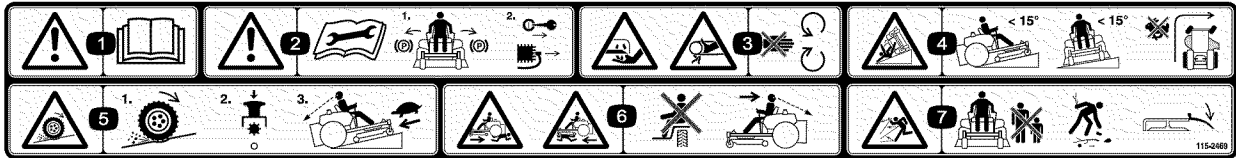

115-2469

1. Warning—read the *Operator's Manual*.
2. Warning—read the instructions before servicing or performing maintenance; move the motion control levers to the park (brake) position, remove the ignition key and disconnect the spark plug wire.
3. Cutting/dismemberment hazard, mower blade; entanglement hazard, belt—do not open or remove safety shields while engine is running.
4. Tipping hazard—do not mow slopes greater than 15 degrees, avoid sudden and sharp turns while on slopes.
5. Loss of traction/control hazard, slopes—loss of traction/control on a slope, disengage the blade control switch (PTO), proceed off the slope slowly.
6. Crushing/dismemberment hazard of bystanders, reversing; crushing/dismemberment hazard of bystanders—do not carry passengers, look behind and down when reversing.
7. Thrown object hazard—keep bystanders a safe distance from the machine, pick up debris before operating, keep deflector in place.

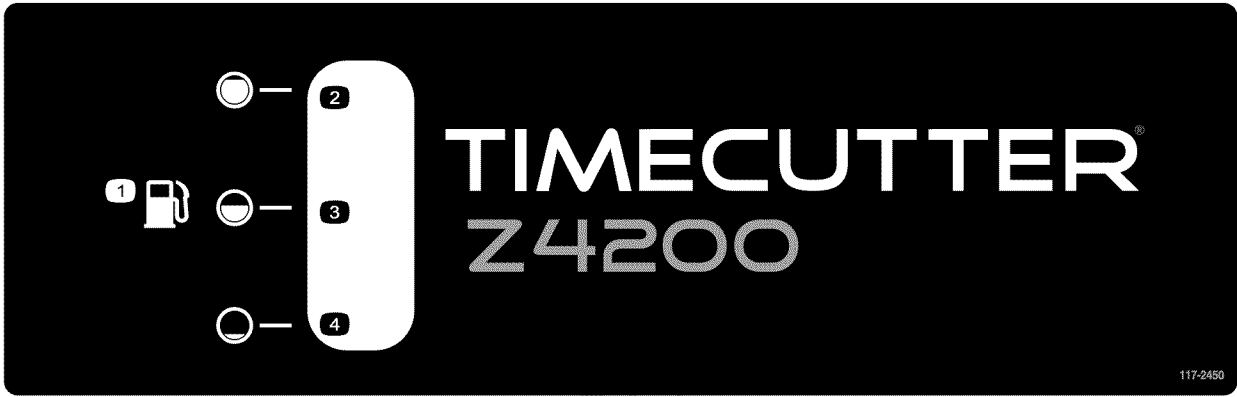

115-2450

1. Fuel gauge                      2. Full                      3. Half                      4. Empty
- 



115-2489

1. Fuel gauge                      2. Full                      3. Half                      4. Empty
- 

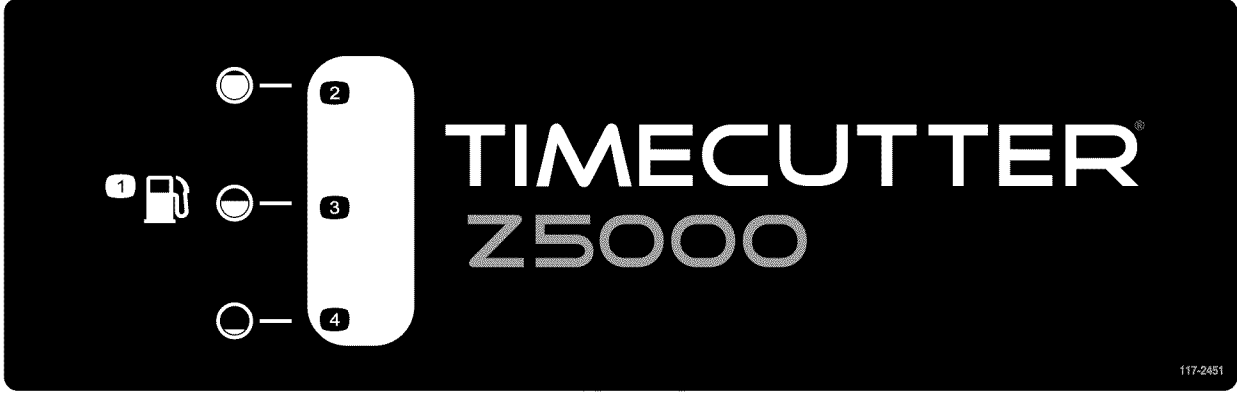

115-2451

1. Fuel gauge                      2. Full                      3. Half                      4. Empty
-

# Product Overview

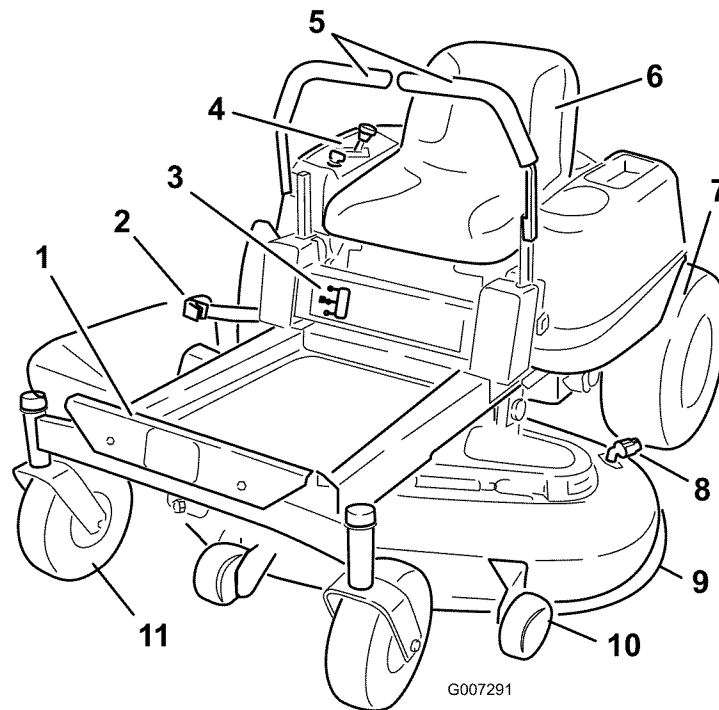

**Figure 3**

- |                        |                          |                     |                        |
|------------------------|--------------------------|---------------------|------------------------|
| 1. Footrest            | 4. Control panel         | 7. Rear drive wheel | 10. Anti-scalp roller  |
| 2. Height of cut lever | 5. Motion control levers | 8. Washout fitting  | 11. Front caster wheel |
| 3. Fuel gauge          | 6. Operator seat         | 9. Mower deck       |                        |

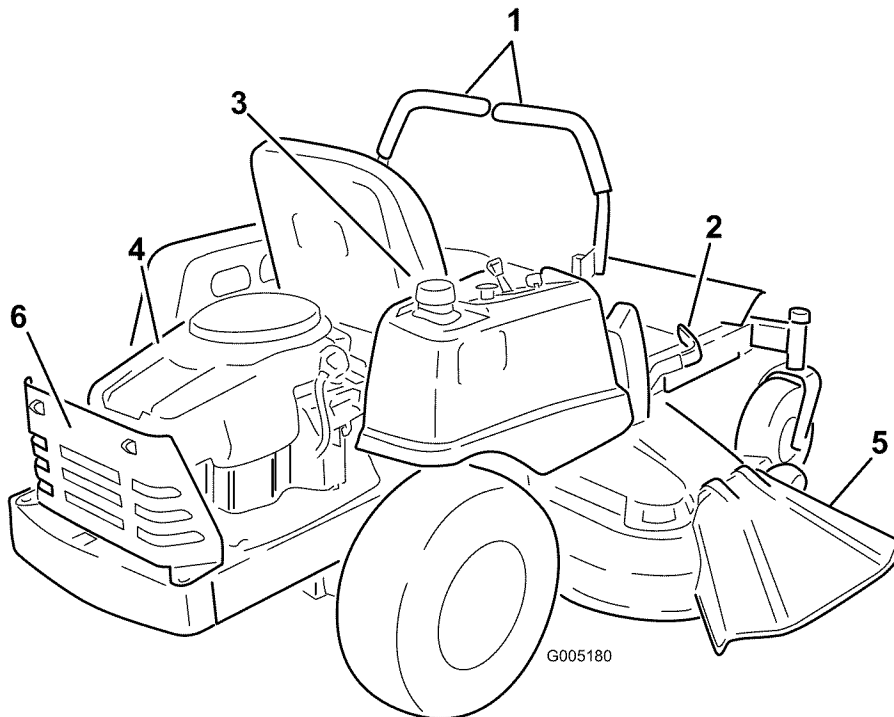
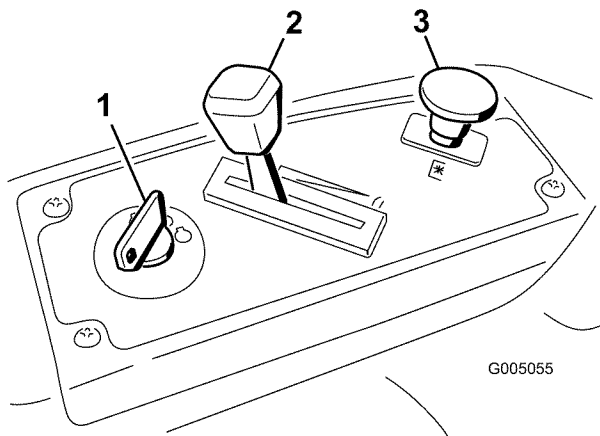

**Figure 4**

- |                          |                 |                                    |
|--------------------------|-----------------|------------------------------------|
| 1. Motion control levers | 3. Gas tank cap | 5. Deflector                       |
| 2. Height of cut lever   | 4. Engine       | 6. Engine guard (Model 74370 only) |

# Controls

Become familiar with all of the controls in Figure 3, Figure 4, and Figure 5 before you start the engine and operate the machine.



**Figure 5**  
Control Panel

- 1. Ignition switch
- 2. Throttle/Choke
- 3. Blade control switch (power take-off)

## Ignition Switch

The ignition switch has three positions, Off, Run and Start. The key will turn to Start and move back to Run upon release. Turning the key to the Off position will stop the engine; however, always remove the key when leaving the machine to prevent someone from accidentally starting the engine (Figure 5).

## Throttle/Choke Control

The throttle and choke is combined into one control lever. The throttle controls the engine speed and it has a continuous variable setting from Slow to Fast. Engage the choke by moving the lever past the Fast setting until it stops (Figure 5).

## Blade Control Switch (Power Take-Off)

The blade control switch, represented by a power take-off (PTO) symbol, engages and disengages power to the mower blades (Figure 5).

## Motion Control Levers and Park Position

The motion control levers are speed sensitive controls of independent wheel motors. Moving a lever forward or backward turns the wheel on the same side forward or in

reverse; wheel speed is proportional to the amount the lever is moved. Move the control levers outward from the center to the park position and exit the machine (Figure 15). Always position the motion control levers into the park position when you stop the machine or leave it unattended.

## Fuel Gauge

The fuel window located below the operator position can be used to verify the level of gasoline in the tank (Figure 6).

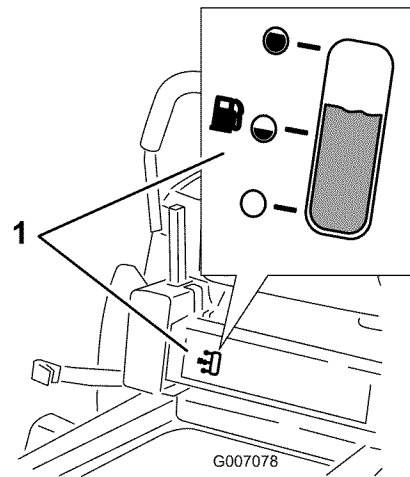

**Figure 6**

- 1. Fuel gauge window

## Height-of-Cut Lever

The height of cut lever allows the operator to lower and raise the deck from the seated position. When the lever is moved up, toward the operator the deck is raised from the ground and when moved down, away from the operator it is lowered toward the ground. Only adjust the height of cut while machine is not moving (Figure 18).

# Operation

**Note:** Determine the left and right sides of the machine from the normal operating position.

## Think Safety First

Please carefully read all of the safety instructions and decals in the safety section. Knowing this information could help you, your family, pets or bystanders avoid injury.

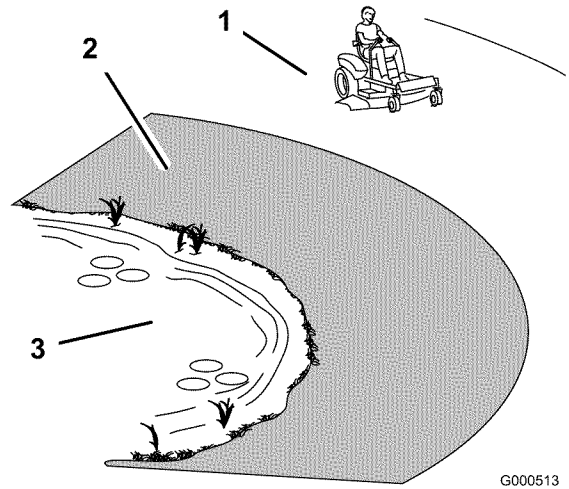

Figure 7

1. Safe Zone-use the TimeCutter here
2. Use walk behind mower and/or hand trimmer near drop-offs and water.
3. Water



Mowing on wet grass or steep slopes can cause sliding and loss of control.

Wheels dropping over edges can cause rollovers, which may result in serious injury, death or drowning.

A loss of traction is a loss of steering control.

To avoid loss of control and possibility of rollover:

- Do not mow near drop-offs or near water.
- Do not mow slopes greater than 15 degrees.
- Reduce speed and use extreme caution on slopes.
- When mowing slopes, gradually work from lower to higher areas on the incline.
- Avoid sudden turns or rapid speed changes.
- Turn up, into an incline when changing directions on slopes. Turning down the slope reduces traction.
- Attachments change the handling characteristics of the machine. Use extra caution when using attachments with the machine.

## Recommended Gasoline

Use UNLEADED Regular Gasoline suitable for automotive use (87 pump octane minimum). Leaded regular gasoline may be used if unleaded regular is not available.

**Important:** Never use methanol, gasoline containing methanol, or gasohol containing more than 10 percent ethanol because the fuel system could be damaged. Do not mix oil with gasoline.



In certain conditions, gasoline is extremely flammable and highly explosive. A fire or explosion from gasoline can burn you and others and can damage property.

- Fill the fuel tank outdoors, in an open area, when the engine is cold. Wipe up any gasoline that spills.
- Never fill the fuel tank inside an enclosed trailer.
- Do not fill the fuel tank completely full. Add gasoline to the fuel tank until the body of the tank is full but fuel does not fill the neck of the tank. This empty space in the tank allows gasoline to expand.
- Never smoke when handling gasoline, and stay away from an open flame or where gasoline fumes may be ignited by a spark.
- Store gasoline in an approved container and keep it out of the reach of children. Never buy more than a 30-day supply of gasoline.
- Do not operate without entire exhaust system in place and in proper working condition.



In certain conditions during fueling, static electricity can be released causing a spark which can ignite the gasoline vapors. A fire or explosion from gasoline can burn you and others and can damage property.

- Always place gasoline containers on the ground away from your vehicle before filling.
- Do not fill gasoline containers inside a vehicle or on a truck or trailer bed because interior carpets or plastic truck bed liners may insulate the container and slow the loss of any static charge.
- When practical, remove gas-powered equipment from the truck or trailer and refuel the equipment with its wheels on the ground.
- If this is not possible, then refuel such equipment on a truck or trailer from a portable container, rather than from a gasoline dispenser nozzle.
- If a gasoline dispenser nozzle must be used, keep the nozzle in contact with the rim of the fuel tank or container opening at all times until fueling is complete.



Gasoline is harmful or fatal if swallowed. Long-term exposure to vapors can cause serious injury and illness.

- Avoid prolonged breathing of vapors.
- Keep face away from nozzle and gas tank or conditioner opening.
- Keep gas away from eyes and skin.

## Using Stabilizer/Conditioner

Use a fuel stabilizer/conditioner in the machine to provide the following benefits:

- Keeps gasoline fresh during storage of 30 days or less. For longer storage it is recommended that the fuel tank be drained.
- Cleans the engine while it runs.
- Eliminates gum-like varnish buildup in the fuel system, which causes hard starting.

Add the correct amount of gas stabilizer/conditioner to the gas.

**Note:** A fuel stabilizer/conditioner is most effective when mixed with fresh gasoline. To minimize the chance of varnish deposits in the fuel system, use fuel stabilizer at all times.

## Gasoline/Alcohol blends

Gasohol (up to 10 percent ethyl alcohol, 90 percent unleaded gasoline by volume) is approved for fuel use by the engine manufacturer. Other gasoline/alcohol blends, such as E85, are not approved.

## Gasoline/Ether blends

Methyl Tertiary Butyl Ether (MTBE) and unleaded gasoline blends (up to a maximum of 15 percent MTBE by volume) are approved for fuel use by the engine manufacturer. Other gasoline/ether blends are not approved.

## Fuel Gauge

Use the fuel window below the operator to verify the level of gasoline before filling the tank (Figure 8).

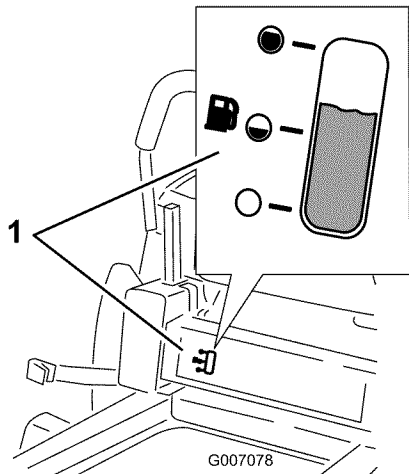

Figure 8

1. Fuel gauge window

## Filling the Fuel Tank

1. Shut the engine off and set the motion controls to the park position. Raise the seat so the gas tank is visible while fueling.
2. Clean around the fuel tank cap and remove the cap.
3. Add unleaded regular gasoline until the body of the tank is full but fuel does not fill the neck of the tank (Figure 9). This space in the neck of the tank

allows gasoline to expand. Do not fill the fuel tank completely full.

4. Install the fuel tank cap securely. Wipe up any gasoline that may have spilled.

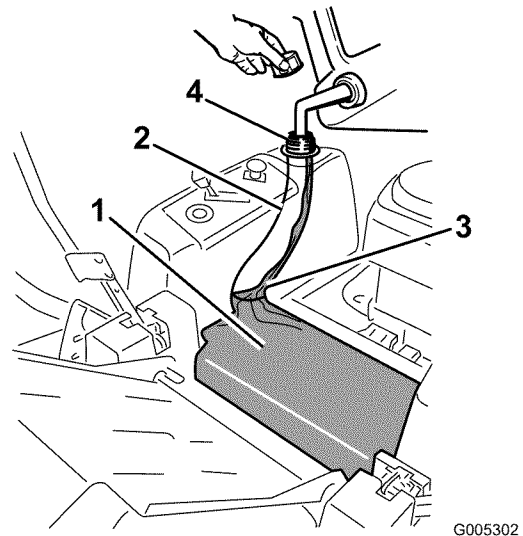

Figure 9

1. Gas tank body
2. Gas tank neck
3. Fill to here, approximately
4. Gas tank opening

## Checking the Engine Oil Level

Before you start the engine and use the machine, check the oil level in the engine crankcase; refer to Checking the Oil Level in the Engine Maintenance section.

## Starting the Engine

1. Sit down on the seat and move the motion controls outward to the park position.
2. Disengage the blades by moving the blade control switch to Off (Figure 10).

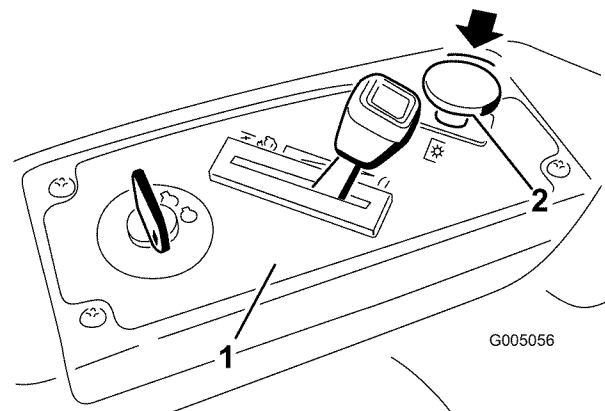

Figure 10

1. Control panel
2. Blade control switch—Off position



3. Move the throttle lever to Choke before starting a cold engine (Figure 11).

**Note:** A warm or hot engine may not require choking.

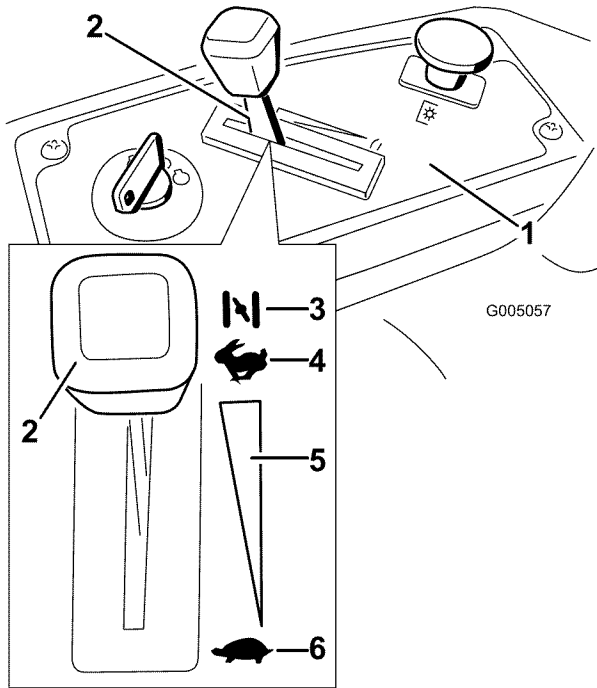

Figure 11

- |  |                                |
|--|--------------------------------|
| 1. Control panel                       | 4. Fast                        |
| 2. Throttle/choke lever—choke position | 5. Continuous variable setting |
| 3. Choke                               | 6. Slow                        |

4. Turn the ignition key to Start to energize the starter. When the engine starts, release the key (Figure 12).

**Important:** Do not engage the starter for more than 10 seconds at a time. If the engine fails to start, allow a 60 second cool-down period between attempts. Failure to follow these instructions can damage the starter motor.

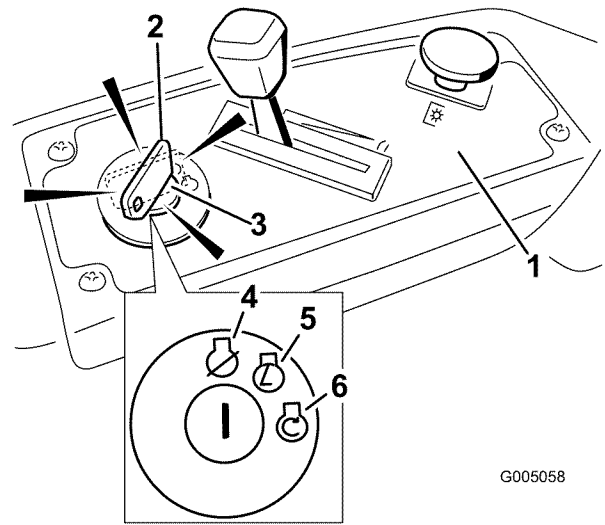

Figure 12

- |                                |          |
|--------------------------------|----------|
| 1. Control panel               | 4. Off   |
| 2. Ignition key—run position   | 5. Run   |
| 3. Ignition key—start position | 6. Start |

5. After the engine starts, move the throttle lever to Fast (Figure 11). If the engine stalls or hesitates, move the throttle lever back to Choke for a few seconds. Repeat this as required.

## Operating the Blades

The blade control switch, represented by a power take-off (PTO) symbol, engages and disengages power to the mower blades. This switch controls power to any attachments that draw power from the engine, including the mower deck and cutting blades.

### Engaging the Blades

**Important:** Do not engage the blades when parked in tall grass. Belt or clutch damage can occur.

1. Release pressure on the motion control levers and place the machine in neutral.
2. Move the throttle to the Fast position.

**Note:** Always engage the blades with the throttle in the Fast position.

3. Pull up on the blade control switch to move it to the On position and engage the blades (Figure 13).

# The Safety Interlock System

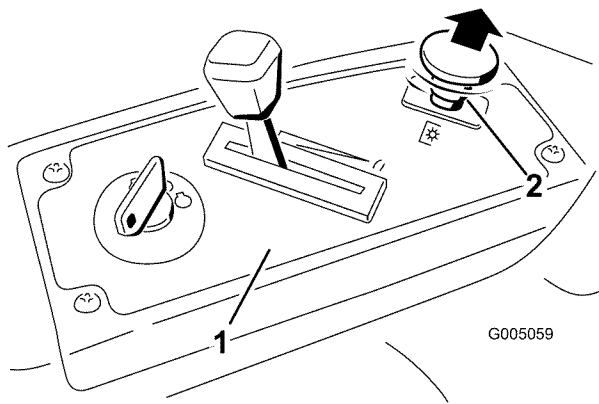

Figure 13

1. Control panel
2. Blade control switch—On position

## Disengaging the Blades

Push down on the blade control switch to move it to the Off position and disengage the blades (Figure 14).

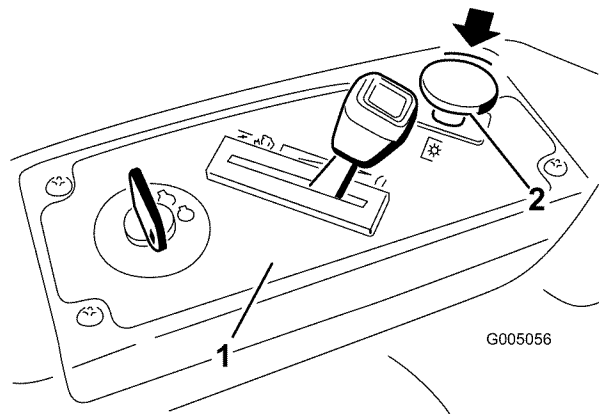

Figure 14

1. Control panel
2. Blade control switch—Off

## Stopping the Engine

1. Disengage the blades by moving the blade control switch to Off (Figure 14).
2. Move the throttle lever to between Fast and half throttle (Figure 12).
3. Turn the ignition key to Off (Figure 11) and remove the key.



If safety interlock switches are disconnected or damaged the machine could operate unexpectedly causing personal injury.

- Do not tamper with the interlock switches.
- Check the operation of the interlock switches daily and replace any damaged switches before operating the machine.

## Understanding the Safety Interlock System

The safety interlock system is designed to prevent the engine from starting unless:

- The blades are disengaged.
- The motion control levers are in the park position.

The safety interlock system also is designed to stop the engine when the control levers are out of the park position and you rise from the seat when the blades are engaged.

## Testing the Safety Interlock System

Test the safety interlock system before you use the machine each time. If the safety system does not operate as described below, have an Authorized Service Dealer repair the safety system immediately.

1. While sitting on the seat, with the control levers in park position, and move the blade control switch to On. Try starting the engine; the engine should not crank.
2. While sitting on the seat, move the blade control switch to Off. Move either motion control lever to the center, unlocked position. Try starting the engine; the engine should not crank. Repeat with the other motion control lever.
3. While sitting on the seat, move the blade control switch to Off, and lock the motion control levers in the park position. Start the engine. While the engine is running, engage the blade control switch, and rise slightly from the seat; the engine should stop.
4. While sitting on the seat, move the blade control switch to Off, and lock the motion control levers in the park position. Start the engine. While the engine is running, move the motion control levers to the center, unlocked position, engage the blade control switch, and rise slightly from the seat; the engine should stop.

# Driving Forward or Backward

The throttle control regulates the engine speed as measured in rpm (revolutions per minute). Place the throttle control in the Fast position for best performance. Always operate in the full throttle position.



The machine can spin very rapidly. The operator may lose control of the machine and cause personal injury or damage to the machine.

- Use caution when making turns.
- Slow the machine down before making sharp turns.

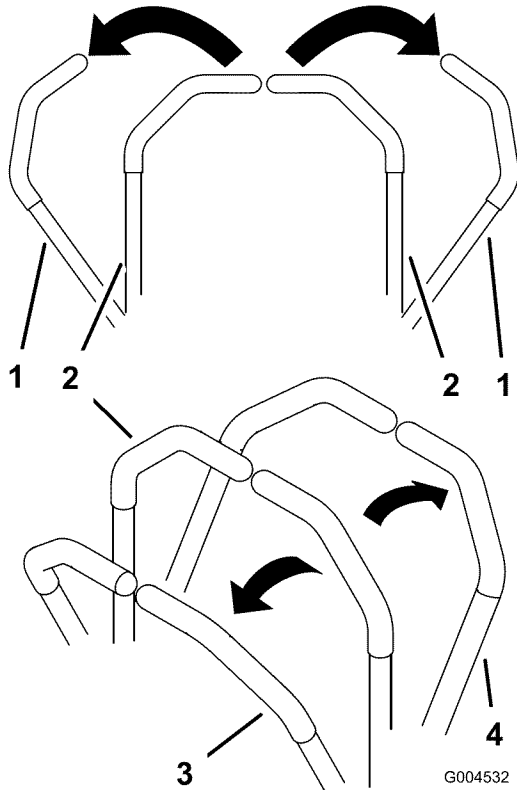

Figure 15

- |                           |             |
|---------------------------|-------------|
| 1. Park (brake) position  | 3. Forward  |
| 2. Center unlock position | 4. Backward |

## Forward

1. Move the levers to the center, unlocked position.
2. To go forward, slowly push the motion control levers forward (Figure 15).

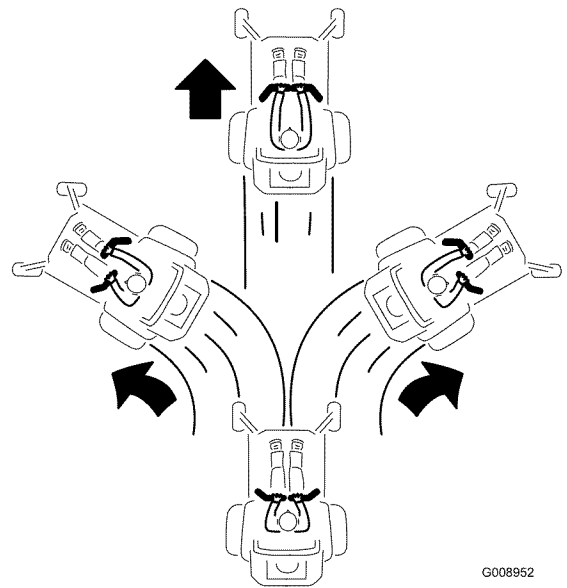

Figure 16

G008952

To go straight, apply equal pressure to both motion control levers (Figure 15).

To turn, release pressure on the motion control lever toward the direction you want to turn (Figure 15).

The farther you move the motion control levers in either direction, the faster the machine will move in that direction.

To stop, pull the motion control levers to neutral.

## Backward

1. Move the levers to the center, unlocked position.
2. To go backward, slowly pull the motion control levers rearward (Figure 17).

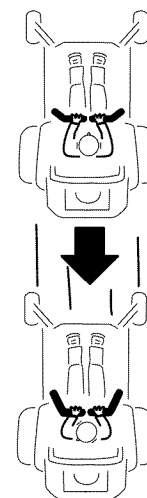

Figure 17

G008953

To go straight, apply equal pressure to both motion control levers (Figure 17).

To turn, release the pressure on the motion control lever toward the direction you want to turn.

To stop, push the motion control levers to neutral.

## Stopping the Machine

To stop the machine, move the motion control levers to neutral and outward to the park position, disengage the blade control switch, ensure the throttle is in the fast position, and turn the ignition key to off. Remember to remove the key from the ignition switch.



**Children or bystanders may be injured if they move or attempt to operate the mower while it is unattended.**

**Always remove the ignition key and move the motion control levers outward to the park position when leaving the machine unattended, even if just for a few minutes.**

## Adjusting the Height of Cut

1. Raise the height-of-cut lever to the transport position, cutting height position 4.5 (also the 4-1/2 inch [115 mm]) (Figure 18).

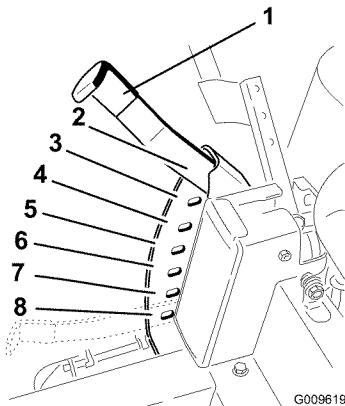

Figure 18

- |   |                     |
|---|---------------------|
| 1. Height-of-cut lever                      | 5. 3 inch (76 mm)   |
| 2. 4.5 inch (115 mm),<br>Transport position | 6. 2.5 inch (64 mm) |
| 3. 4 inch (102 mm)                          | 7. 2 inch (51 mm)   |
| 4. 3.5 inch (89 mm)                         | 8. 1.5 inch (38 mm) |

2. To adjust the height of cut, pull inward and up on the lever and move it to the desired position.

## Positioning the Seat

The seat can move forward and backward. Position the seat where you have the best control of the machine and are most comfortable.

1. Raise the seat and loosen the adjustment knob just enough that seat can move (Figure 19).

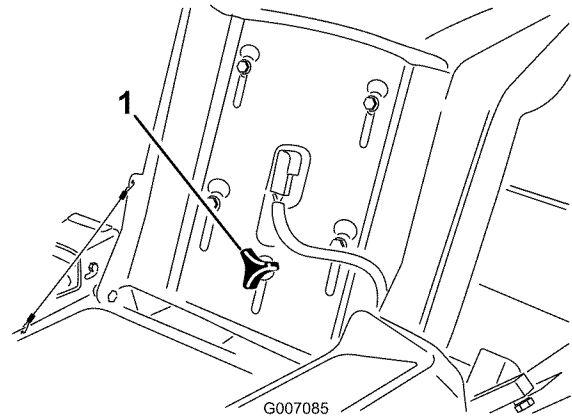

Figure 19

1. Adjustment knob
2. Move the seat to the desired position and tighten the knob.

## Adjusting the Motion Control Levers

### Adjusting the Height

The motion control levers can be adjusted higher or lower for maximum operator comfort.

1. Remove the 2 bolts holding the control lever to the control arm shaft (Figure 20).
2. Move the control lever to the next set of holes. Secure the lever with the 2 bolts (Figure 20).

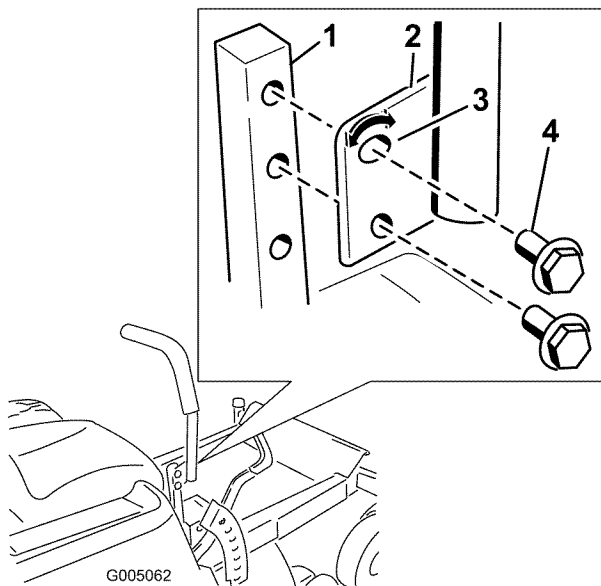

**Figure 20**

- |                      |                        |
|----------------------|------------------------|
| 1. Control arm shaft | 3. Slotted, upper hole |
| 2. Control lever     | 4. Bolt                |

3. Repeat the adjustment for the opposite control lever.

## Adjusting the Tilt

The motion control levers can be tilted fore or aft for maximum operator comfort.

1. Loosen the upper bolt holding the control lever to the control arm shaft.
2. Loosen the lower bolt just enough to pivot the control lever fore or aft (Figure 20). Tighten both bolts to secure the control in the new position.
3. Repeat the adjustment for the opposite control lever.

## Pushing the Machine by Hand

**Important:** Always push the machine by hand. Never tow the machine because damage may occur.

### To Push the Machine

1. Park the machine on a level surface and disengage the blade control switch.
2. Move the motion control levers outward to park position, stop the engine, remove the key, and wait for all moving parts to stop before leaving the operating position.
3. Locate the bypass levers at the rear of the machine, on the left and right side of the frame.

4. Move the bypass levers rearward and then down to lock them in place as shown in Figure 21 to disengage the wheel motors. Repeat this on each side of the machine.
5. Move the motion control levers inward to the neutral position.

The machine is now able to be pushed by hand.

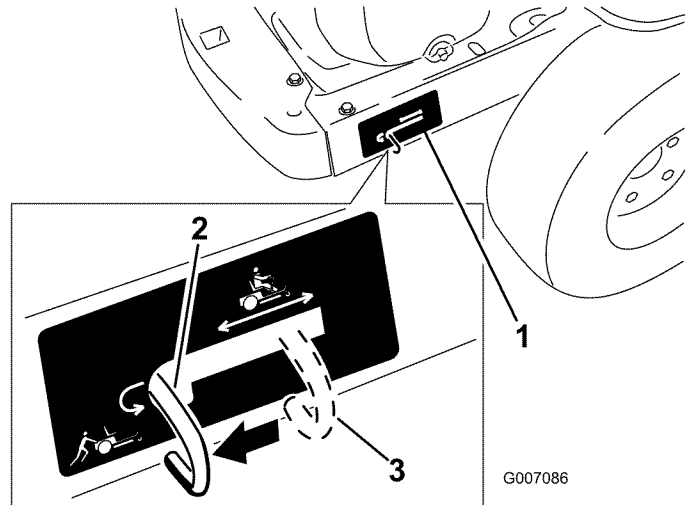

**Figure 21**

Right side shown

- |   |   |
|---|---|
| 1. Bypass lever location                  | 3. Lever position for operating the machine |
| 2. Lever position for pushing the machine |   |

## To Operate the Machine

Move the bypass levers upward and push them forward, to the **middle** of the horizontal slot (Figure 21) to engage the wheel motors.

## Grass Deflector

The mower has a hinged grass deflector that disperses clippings to the side and down toward the turf.



**Without the grass deflector, discharge cover, or complete grass catcher assembly mounted in place, you and others are exposed to blade contact and thrown debris. Contact with rotating mower blade(s) and thrown debris will cause injury or death.**

- **Never remove the grass deflector from the mower because the grass deflector routes material down toward the turf. If the grass deflector is ever damaged, replace it immediately.**
- **Never put your hands or feet under the mower.**
- **Never try to clear discharge area or mower blades unless you move the blade control switch to Off and rotate the ignition key to Off. Also remove the key and pull the wire off the spark plug(s).**

## Operating Tips

### Fast Throttle Setting

For best mowing and maximum air circulation, operate the engine at the Fast position. Air is required to thoroughly cut grass clippings, so do not set the height-of-cut so low as to totally surround the mower by uncut grass. Always try to have one side of the mower free from uncut grass, which allows air to be drawn into the mower.

### Cutting a Lawn for the First Time

Cut grass slightly longer than normal to ensure that the cutting height of the mower does not scalp any uneven ground. However, the cutting height used in the past is generally the best one to use. When cutting grass longer than six inches tall, you may want to cut the lawn twice to ensure an acceptable quality of cut.

### Cut 1/3 of the Grass Blade

It is best to cut only about 1/3 of the grass blade. Cutting more than that is not recommended unless grass is sparse, or it is late fall when grass grows more slowly.

## Mowing Direction

Alternate mowing direction to keep the grass standing straight. This also helps disperse clippings which enhances decomposition and fertilization.

## Mow at Correct Intervals

Normally, mow every four days. But remember, grass grows at different rates at different times. So to maintain the same cutting height, which is a good practice, mow more often in early spring. As the grass growth rate slows in mid summer, mow less frequently. If you cannot mow for an extended period, first mow at a high cutting height; then mow again two days later at a lower height setting.

## Cutting Speed

To improve cut quality, use a slower ground speed.

## Avoid Cutting Too Low

If the cutting width of the mower is wider than the mower you previously used, raise the cutting height to ensure that uneven turf is not cut too short.

## Long Grass

If the grass is ever allowed to grow slightly longer than normal, or if it contains a high degree of moisture, raise the cutting height higher than usual and cut the grass at this setting. Then cut the grass again using the lower, normal setting.

## When Stopping

If the machine's forward motion must be stopped while mowing, a clump of grass clippings may drop onto your lawn. To avoid this, move onto a previously cut area with the blades engaged.

## Keep the Underside of the Mower Clean

Clean clippings and dirt from the underside of the mower after each use. If grass and dirt build up inside the mower, cutting quality will eventually become unsatisfactory.

## Blade Maintenance

Maintain a sharp blade throughout the cutting season because a sharp blade cuts cleanly without tearing or shredding the grass blades. Tearing and shredding turns grass brown at the edges, which slows growth and

increases the chance of disease. Check the cutter blades daily for sharpness, and for any wear or damage. File down any nicks and sharpen the blades as necessary. If a blade is damaged or worn, replace it immediately with a genuine Toro replacement blade.

# Maintenance

**Note:** Determine the left and right sides of the machine from the normal operating position.

## ***Recommended Maintenance Schedule(s)***

Maintenance Service Interval	Maintenance Procedure
Before each use or daily	<ul style="list-style-type: none"><li>• Check the safety interlock system.</li><li>• Check the air cleaner for dirty, loose or damaged parts.</li><li>• Check the engine oil level.</li><li>• Check air intake and cooling areas, clean as necessary.</li><li>• Check the cutting blades.</li><li>• Inspect the grass deflector for damage</li><li>• Clean the mower housing.</li></ul>
Every 25 hours	<ul style="list-style-type: none"><li>• Grease all lubrication points.</li><li>• Service the paper element. (more often under extremely dusty, dirty conditions)</li><li>• Check tire pressure.</li><li>• Check the belts for wear/cracks.</li></ul>
Every 100 hours	<ul style="list-style-type: none"><li>• Replace the paper element. (more often under extremely dusty, dirty conditions)</li><li>• Change the engine oil and filter.</li><li>• Clean the blower housing (more often under extremely dusty, dirty conditions).</li><li>• Replace the fuel filter.</li></ul>
Every 200 hours	<ul style="list-style-type: none"><li>• Check spark plug condition and gap.</li></ul>
Every 500 hours	<ul style="list-style-type: none"><li>• Replace the spark plug.</li></ul>
Before storage	<ul style="list-style-type: none"><li>• Charge the battery and disconnect battery cables.</li><li>• Perform all maintenance procedures listed above before storage.</li><li>• Paint any chipped surfaces.</li></ul>

**Important:** Refer to your engine operator's manual for additional maintenance procedures.



If you leave the key in the ignition switch, someone could accidentally start the engine and seriously injure you or other bystanders.

Remove the key from the ignition and disconnect the wire from the spark plug before you do any maintenance. Set the wire aside so that it does not accidentally contact the spark plug.



# Premaintenance Procedures

## Raising the Seat

Make sure the motion control levers are locked in the park position. Lift the seat forward.

The following components can be accessed by raising the seat:

- Serial plate
- Service decal
- Seat adjustment knob
- Fuel filter
- Fuses
- Battery cables

## Accessing the Battery

1. Raise the seat.
2. Remove the TORX® head fasteners (T25) securing the left cover to the frame as shown in Figure 22.

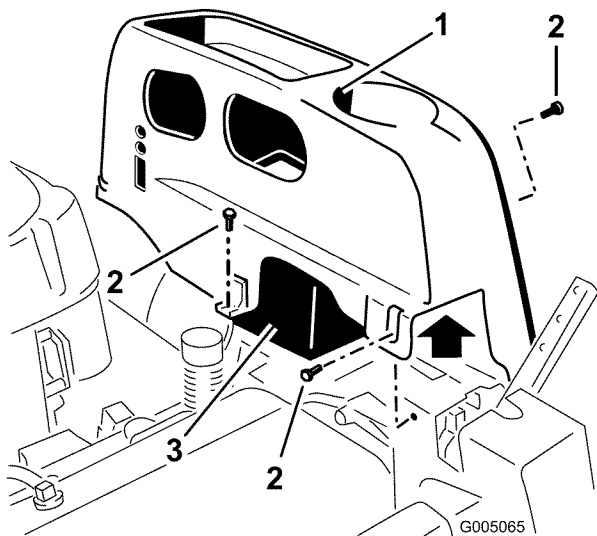

Figure 22

1. Left cover
2. Torx head fasteners (T25)
3. Battery

3. Lift the plastic cover away from the machine. Retain all fasteners.

Replace the cover and secure it to the frame using the fasteners removed previously.

# Lubrication

## Greasing the Bearings

**Service Interval:** Every 25 hours—Grease all lubrication points.

**Grease Type:** No. 2 General Purpose Lithium Base Grease

1. Park the machine on a level surface and disengage the blade control switch.
2. Move the motion control levers outward to the park position, stop the engine, remove the key, and wait for all moving parts to stop before leaving the operating position.
3. Clean the grease fittings (Figure 23 and Figure 24) with a rag. Make sure to scrape any paint off of the front of the fitting(s).

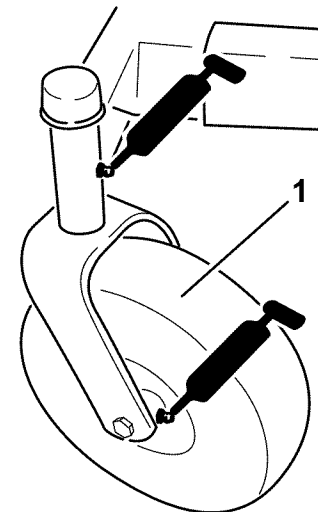

Figure 23

1. Front caster tire

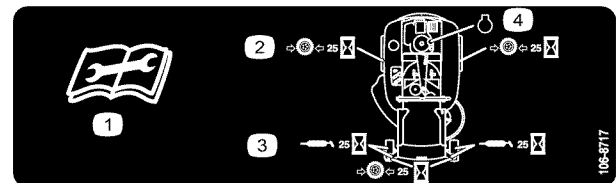

Figure 24

Located on the seat pan underside

1. Read the instructions before servicing or performing maintenance.
2. Check tire pressure every 25 operating hours.
3. Grease every 25 operating hours.
4. Engine

4. Connect a grease gun to each fitting (Figure 23 and Figure 24). Pump grease into the fittings until grease begins to ooze out of the bearings.
5. Wipe up any excess grease.

# Engine Maintenance

## Servicing the Air Cleaner

**Service Interval:** Before each use or daily—Check the air cleaner for dirty, loose or damaged parts.

This engine is equipped with a replaceable, high density paper air cleaner element. Check the air cleaner daily or before starting the engine. Check for a buildup of dirt and debris around the air cleaner system. Keep this area clean. Also check for loose or damaged components. Replace all bent or damaged air cleaner components.

**Note:** Operating the engine with loose or damaged air cleaner components could allow unfiltered air into the engine causing premature wear and failure.

**Note:** Service the air cleaner more often under extremely dusty, dirty conditions.

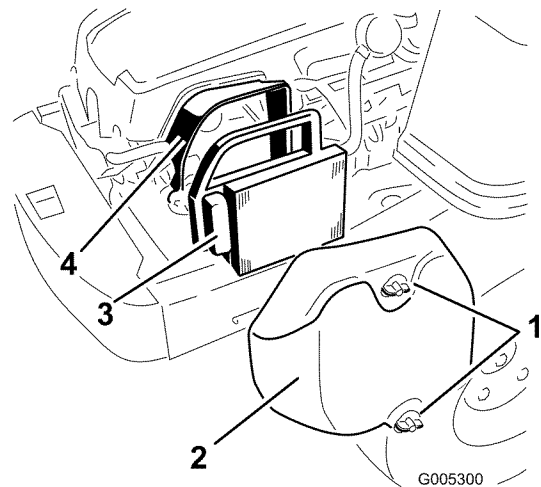

**Figure 25**

- |                             |                     |
|-----------------------------|---------------------|
| 1. Knobs, air cleaner cover | 3. Paper element    |
| 2. Air cleaner cover        | 4. Air cleaner base |

## Servicing Paper Element

**Service Interval:** Every 25 hours—Service the paper element. (more often under extremely dusty, dirty conditions)

Every 100 hours—Replace the paper element. (more often under extremely dusty, dirty conditions)

1. Remove the air cleaner cover (Figure 25).
2. Remove the air cleaner element with the integral rubber seal (Figure 25).
3. Gently tap the pleated side of the paper element to dislodge dirt. Do not wash the paper element or use pressurized air, as this will damage the element.

Replace a dirty, bent, or damaged element. Handle new elements carefully; do not use if the rubber seal is damaged.

- Clean all air cleaner components of any accumulated dirt or foreign material. Prevent any dirt from entering the carburetor.
- Install the air cleaner element with the pleated side “out” and seat the rubber seal onto the edges of the air cleaner base (Figure 25).
- Reinstall the air cleaner cover and secure with the two knobs (Figure 25).

## Servicing the Engine Oil

**Oil Type:** Detergent oil (API service SG, SH, SJ, or higher)

**Crankcase Capacity:** 1.6 qt (1.5 l) when the filter is changed

**Viscosity:** See the table below.

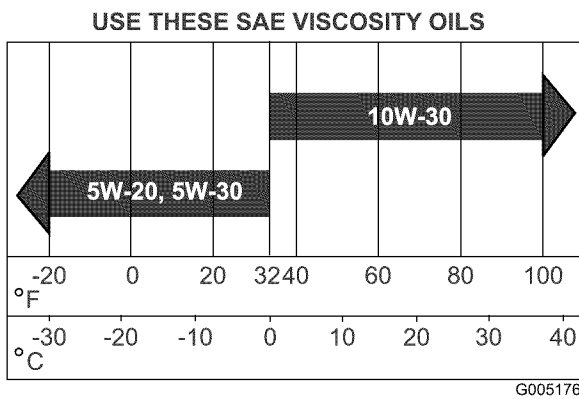
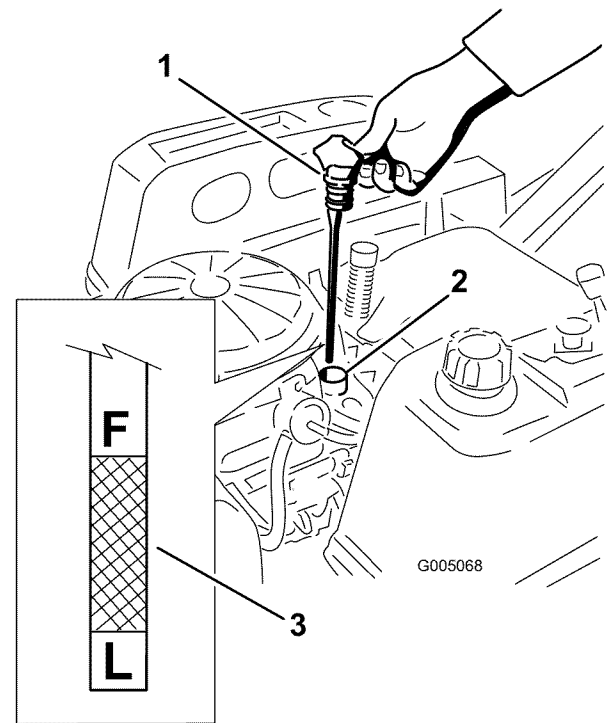

**Figure 26**

## Checking the Oil Level

**Service Interval:** Before each use or daily—Check the engine oil level.

- Park the machine on a level surface, disengage the blade control switch, stop the engine, and remove the key.
- Make sure the engine is stopped, level, and is cool so the oil has had time to drain into the sump.
- To keep dirt, grass clippings, etc., out of the engine, clean the area around the oil fill cap/dipstick before removing it.
- Pull and remove the oil fill cap/dipstick; wipe oil off. Reinsert the dipstick and push firmly into place (Figure 27).



**Figure 27**

- Oil dipstick
- Filler tube
- Oil level

- Remove the dipstick and check the oil level. (Figure 27).

The oil level should be up to, but not over, the **F** mark on the dipstick.

- If the level is low, add oil of the proper type, up to the **F** mark on the dipstick. Always check the level with the dipstick before adding more oil.

**Note:** To prevent extensive engine wear or damage, always maintain the proper oil level in the crankcase. Never operate the engine with the oil level below the “L” mark or over the “F” mark on the dipstick.

## Changing the Oil and the Filter

**Service Interval:** Every 100 hours—Change the engine oil and filter.

Refill with service class SG, SH, SJ or higher oil as specified in the “Viscosity Grades” table.

Change the oil and filter while the engine is still warm. The oil will flow more freely and carry away more impurities. Make sure the engine is level when filling, checking, or changing the oil.

Change the oil and oil filter as follows:

- Start the engine and let it run until warm. This warms the oil so it drains better.

2. Park the machine so that the drain side is slightly lower than the opposite side to assure the oil drains completely.
3. Disengage the blade control switch and move the motion controls outward to the park position.
4. Stop the engine, remove the key, and wait for all moving parts to stop before leaving the operating position.
5. Clean the area around the drain valve and on the machine frame. Locate the oil drain hose and slide it over the drain valve (Figure 28).

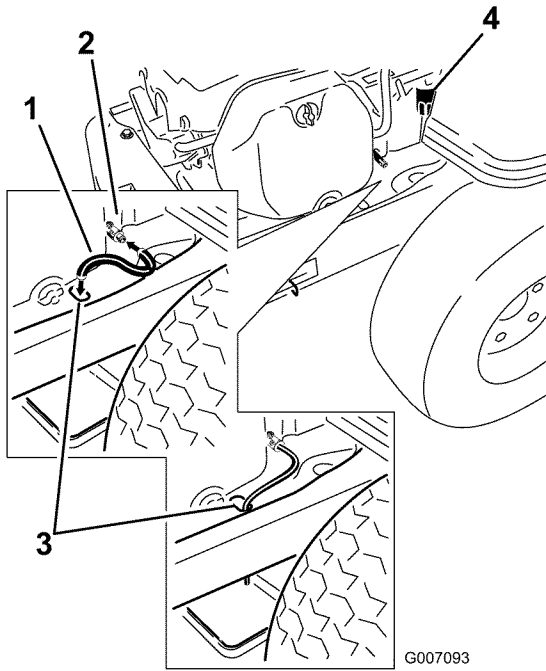

**Figure 28**

- |                   |                  |
|-------------------|------------------|
| 1. Oil drain hose | 3. Hole in frame |
| 2. Drain valve    | 4. Oil filter    |

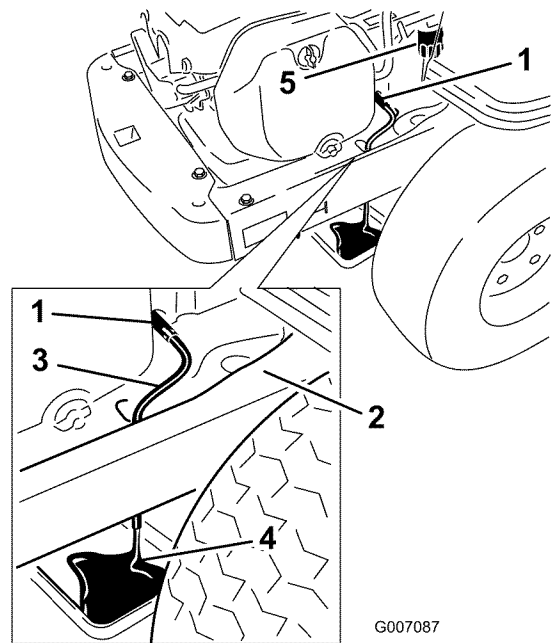

**Figure 29**

- |                    |               |
|--------------------|---------------|
| 1. Oil drain valve | 4. Pan        |
| 2. Machine frame   | 5. Oil filter |
| 3. Oil drain hose  |               |

6. Place the opposite end of the oil drain hose through the drain hole in the frame (Figure 28).
7. Place a pan underneath machine directly below the drain hole in the frame as shown in Figure 29.

8. Turn the drain valve 1/4 counter clockwise to open and allow the oil to drain (Figure 29). Remove the oil fill cap/dipstick (Figure 27).
9. Be sure to allow ample time for complete drainage.
10. Remove the old filter and wipe off the mounting pad (Figure 29).
11. When oil has drained completely, close the oil drain valve. Remove the oil drain hose and wipe up any excess oil on the frame (Figure 29).

**Note:** Dispose of the used oil at a recycling center.

12. Place the new replacement filter in a shallow pan with the open end up. Pour new oil of the proper type, in through the threaded center hole. Stop pouring when the oil reaches the bottom of the threads. Allow a minute or two for the oil to be absorbed by the filter material.
13. Apply a thin film of clean oil to the rubber gasket on the new filter.
14. Install the replacement oil filter to the mounting pad. Turn the oil filter clockwise until the rubber gasket contacts the pad, then tighten the filter an additional 2/3 to 1 turn (Figure 30).

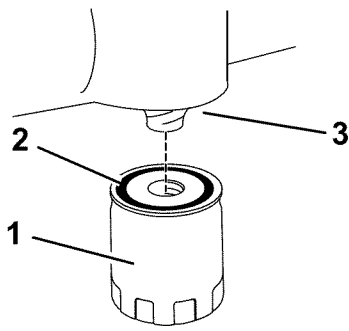

G005177

**Figure 30**

1. Oil filter
2. Gasket
3. Adapter

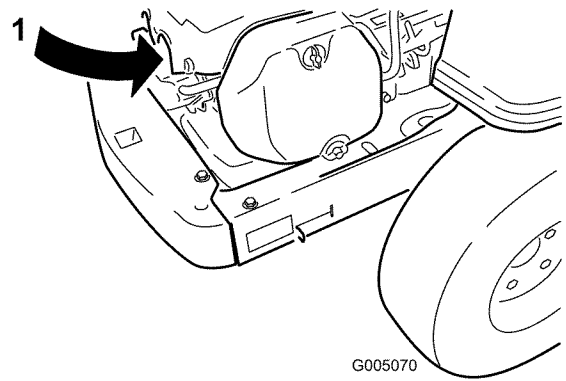

G005070

**Figure 31**

1. Spark plug and wire location

15. Slowly pour approximately 80% of the specified oil into the filler tube (Figure 27).
16. Install the oil fill cap/dipstick and push firmly into place (Figure 27).
17. Check the oil level (Figure 27); refer to Checking the Oil Level.
18. Slowly add additional oil to bring it to the full mark.
19. Install the oil fill cap/dipstick and push firmly into place (Figure 27).

## Servicing the Spark Plug

**Service Interval:** Every 200 hours—Check spark plug condition and gap.  
Every 500 hours—Replace the spark plug.

The spark plug is RFI compliant. Equivalent alternate brand plugs can also be used. Spark plug replacement is recommended at 500 hours.

Type: Champion XC12YC (or equivalent)

Air Gap: 0.030 inch (0.76 mm)

## Removing the Spark Plug

1. Disengage the blade control switch, move the motion controls outward to the park position, stop the engine, and remove the key.
2. Pull the wire off of the spark plug (Figure 31). Clean around the spark plug to prevent dirt from falling into the engine and potentially causing damage.

**Note:** Due to the deep recess around the spark plug, blowing out the cavity with compressed air is usually the most effective method for cleaning. The spark plug is most accessible when the blower housing is removed for cleaning.

3. Remove the spark plug and metal washer.

## Checking the Spark Plug

1. Look at the center of the spark plug (Figure 32). If you see light brown or gray on the insulator, the engine is operating properly. A black coating on the insulator usually means the air cleaner is dirty.
- Important:** Never clean the spark plug. Always replace the spark plug when it has a black coating, worn electrodes, an oily film, or cracks.
2. Check the gap between the center and side electrodes (Figure 32). Bend the side electrode (Figure 32) if the gap is not correct.

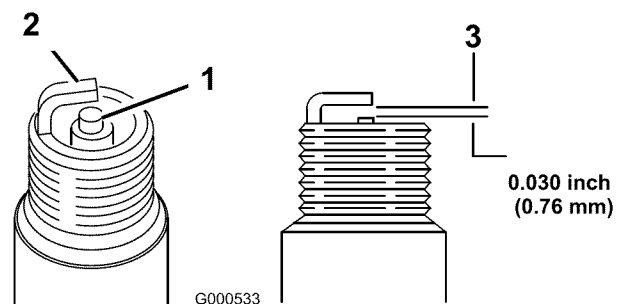

G000533

**Figure 32**

1. Center electrode insulator
2. Side electrode
3. Air gap (not to scale)

## Installing the Spark Plug

1. Install the spark plug. Make sure that the air gap is set correctly.
2. Tighten the spark plug to 30 ft-lb (41 N-m).
3. Push the wire onto the spark plug (Figure 31).

## Cleaning the Blower Housing

To ensure proper cooling, make sure the grass screen, cooling fins, and other external surfaces of the engine are kept clean at all times.

Annually or every 100 hours of operation (more often under extremely dusty, dirty conditions), remove the blower housing and any other cooling shrouds. Clean the cooling fins and external surfaces as necessary. Make sure the cooling shrouds are reinstalled. Torque the blower housing screws to 5.5 ft-lb (7.5 N-m).

**Important:** Operating the engine with a blocked grass screen, dirty or plugged cooling fins, and/or cooling shrouds removed, will cause engine damage due to overheating.

## Fuel System Maintenance



In certain conditions, gasoline is extremely flammable and highly explosive. A fire or explosion from gasoline can burn you and others and can damage property.

- Perform any fuel related maintenance when the engine is cold. Do this outdoors in an open area. Wipe up any gasoline that spills.
- Never smoke when draining gasoline, and stay away from an open flame or where a spark may ignite the gasoline fumes.

## Replacing the Fuel Filter

**Service Interval:** Every 100 hours—Replace the fuel filter.

Never install a dirty filter if it is removed from the fuel line.

1. Park the machine on a level surface and disengage the blade control switch.
2. Move the motion control levers outward to the park position, stop the engine, remove the key, and wait for all moving parts to stop before leaving the operating position.
3. Raise the seat and locate the fuel line coming from the fuel tank below. The fuel filter is in the fuel line between the tank and engine.

# Electrical System Maintenance

## Warning

### CALIFORNIA

#### Proposition 65 Warning

Battery posts, terminals, and related accessories contain lead and lead compounds, chemicals known to the State of California to cause cancer and reproductive harm.

Wash hands after handling.

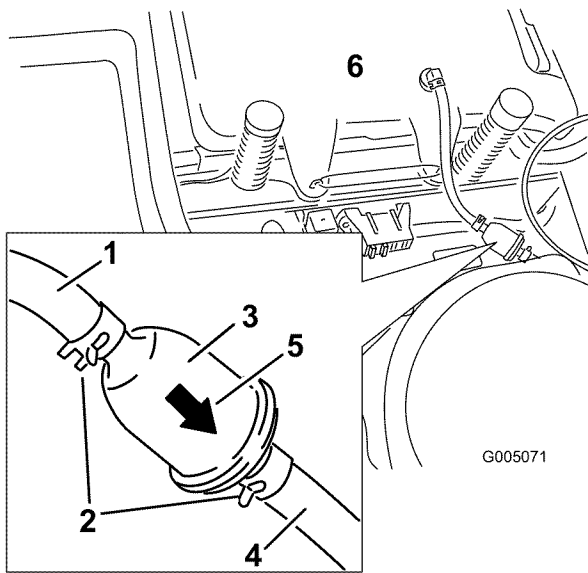

Figure 33

- |                        |                         |
|------------------------|-------------------------|
| 1. Fuel line from tank | 4. Fuel line to engine  |
| 2. Hose clamp          | 5. Flow direction arrow |
| 3. Filter              | 6. Fuel tank            |

4. Squeeze the ends of the hose clamps together and slide them away from the filter (Figure 33).
5. Remove the filter from the fuel lines.
6. Install a new filter with the flow direction arrow coming from the fuel tank and pointing to the engine. Move the hose clamps close to the filter (Figure 33) to secure it in place.

## Charging the Battery

## Removing the Battery



**Battery terminals or metal tools could short against metal machine components causing sparks. Sparks can cause the battery gasses to explode, resulting in personal injury.**

- **When removing or installing the battery, do not allow the battery terminals to touch any metal parts of the machine.**
- **Do not allow metal tools to short between the battery terminals and metal parts of the machine.**

1. Park the machine on a level surface and disengage the blade control switch.
2. Move the motion control levers outward to the park position, stop the engine, remove the key, and wait for all moving parts to stop before leaving the operating position.
3. Remove the left side console to access the battery. Refer the Accessing the Battery procedure in the Premaintenance Procedures for instructions.
4. Disconnect the negative (black) ground cable from the battery post (Figure 34). Retain all fasteners.



Incorrect battery cable routing could damage the machine and cables causing sparks. Sparks can cause the battery gasses to explode, resulting in personal injury.

- Always disconnect the negative (black) battery cable before disconnecting the positive (red) cable.
- Always connect the positive (red) battery cable before connecting the negative (black) cable.

- Slide the rubber cover up the positive (red) cable. Disconnect the positive (red) cable from the battery post (Figure 34). Retain all fasteners.
- Remove the battery hold-down (Figure 34) and lift the battery from the battery tray.

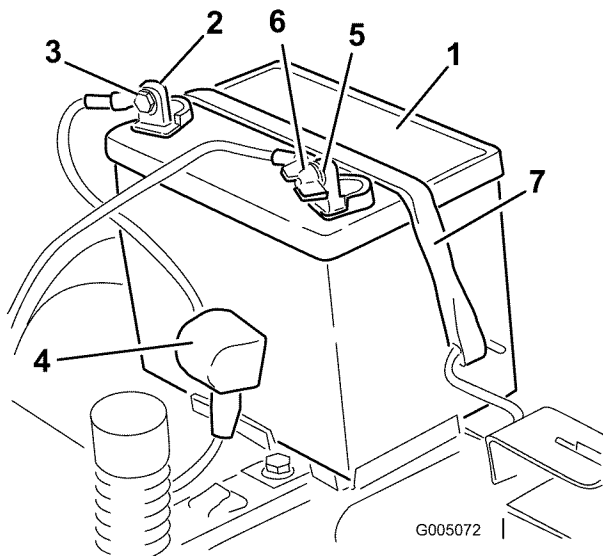

Figure 34

- |                          |                               |
|--------------------------|-------------------------------|
| 1. Battery               | 5. Negative battery post      |
| 2. Positive battery post | 6. Wing nut, washer, and bolt |
| 3. Bolt, washer, and nut | 7. Battery hold-down          |
| 4. Terminal boot         |                               |

## Charging the Battery

**Service Interval:** Before storage—Charge the battery and disconnect battery cables.

- Remove the battery from the chassis; refer to Removing the Battery.
- Charge the battery for a minimum of 1 hour at 6 to 10 amps. Do not overcharge the battery.
- When the battery is fully charged, unplug the charger from the electrical outlet, then disconnect the charger leads from the battery posts (Figure 35).

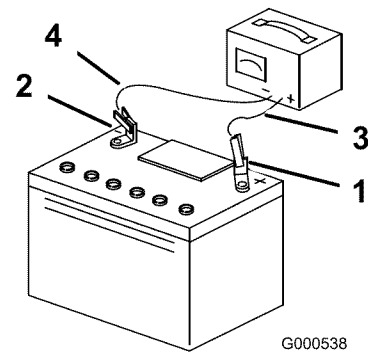

Figure 35

- |                          |                           |
|--------------------------|---------------------------|
| 1. Positive battery post | 3. Red (+) charger lead   |
| 2. Negative battery post | 4. Black (-) charger lead |

**Note:** Do not run the machine with the battery disconnected, electrical damage may occur.

## Installing the Battery

- Position the battery in the tray with the terminal posts toward the operating position (Figure 34).
- Install the positive (red) battery cable to the positive (+) battery terminal using the fasteners removed previously.
- Install the negative battery cable to the negative (-) battery terminal using the fasteners removed previously.
- Slide the red terminal boot onto the positive (red) battery post.
- Secure the battery with the hold-down (Figure 34).
- Install the left side console. Refer to the Accessing the Battery procedure in Premaintenance Procedures for instructions.

## Servicing the Fuses

The electrical system is protected by fuses. It requires no maintenance; however, if a fuse blows, check the component/circuit for a malfunction or short.

Fuse:

- Main F1-30 amp, blade-type
  - Charge Circuit F2-25 amp, blade-type
- Raise the seat to gain access to the fuse holder (Figure 36).
  - To replace a fuse, pull out on the fuse to remove it (Figure 36).



# Drive System Maintenance

## Checking the Tire Pressure

**Service Interval:** Every 25 hours—Check tire pressure.

Maintain the air pressure in the front and rear tires as specified. Uneven tire pressure can cause uneven cut. Check the pressure at the valve stem (Figure 37). Check the tires when they are cold to get the most accurate pressure reading.

### Tire Pressures

Model	Rear Tire	Front Tire (caster wheels)
74360	13 psi (90 kPa)	35 psi (241 kPa)
74363		20 psi (138 kPa)
74370		20 psi (138 kPa)

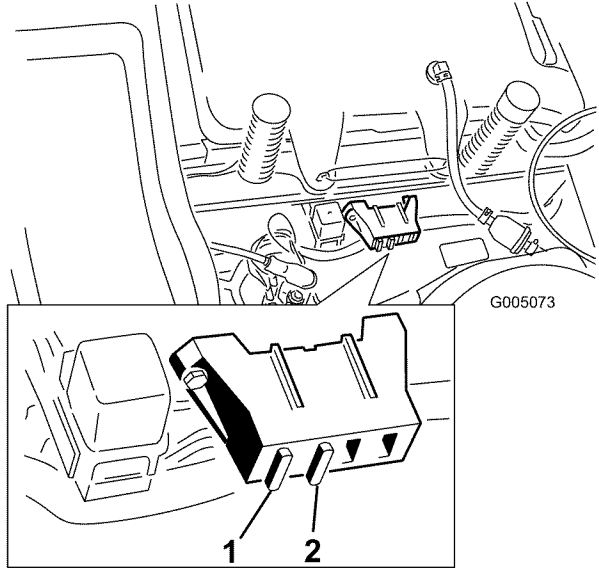

**Figure 36**

- 1. Main-30 amp
- 2. Charge circuit-25 amp

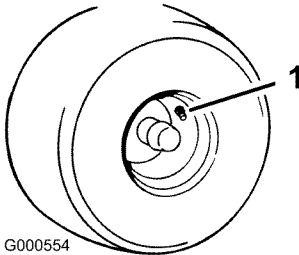

**Figure 37**

- 1. Valve stem

# Mower Maintenance

## Servicing the Cutting Blades

Maintain sharp blades throughout the cutting season because sharp blades cut cleanly without tearing or shredding the grass blades. Tearing and shredding turns grass brown at the edges, which slows growth and increases the chance of disease.

Check the cutter blades daily for sharpness, and for any wear or damage. File down any nicks and sharpen the blades as necessary. If a blade is damaged or worn, replace it immediately with a genuine Toro replacement blade. For convenient sharpening and replacement, you may want to keep extra blades on hand.



**A worn or damaged blade can break, and a piece of the blade could be thrown into the operator's or bystander's area, resulting in serious personal injury or death.**

- Inspect the blade periodically for wear or damage.
- Replace a worn or damaged blade.

## Before Inspecting or Servicing the Blades

Park the machine on a level surface, disengage the blade control switch, and move the motion control levers outward to the park position. Stop the engine and remove the key.

## Inspecting the Blades

**Service Interval:** Before each use or daily—Check the cutting blades.

1. Inspect the cutting edges (Figure 38). If the edges are not sharp or have nicks, remove and sharpen the blades; refer to Sharpening the Blades.
2. Inspect the blades, especially the curved area (Figure 38). If you notice any damage, wear, or a slot forming in this area (item 3 in Figure 38), immediately install a new blade.

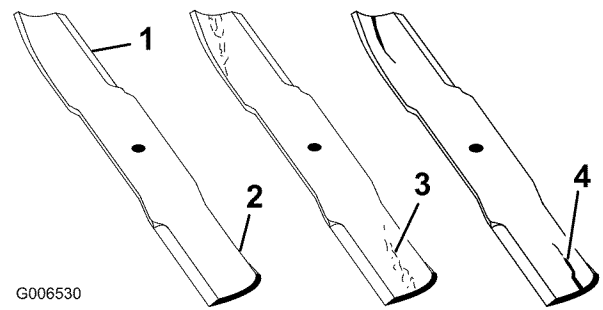

Figure 38

1. Cutting edge
2. Curved area
3. Wear/slot forming
4. Damage

## Checking for Bent Blades

**Note:** The machine must be on a level surface for the following procedure.

1. Raise the mower deck to the highest height-of-cut position; also considered the 'transport' position.
2. While wearing thickly padded gloves or other adequate hand protection slowly rotate blade to be measure into a position that allows effective measurement of the distance between the cutting edge and the level surface the machine is on.

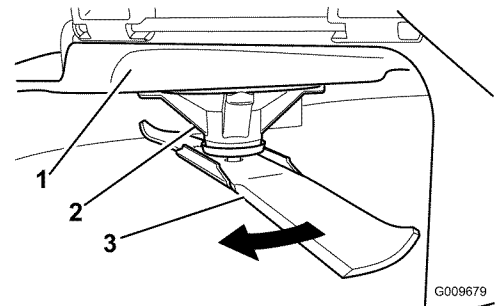
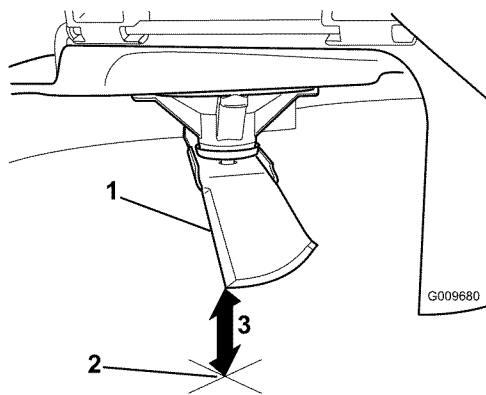

Figure 39

1. Deck
2. Spindle housing
3. Blade

3. Measure from the tip of the blade to the flat surface here.



**Figure 40**

1. Blade, in position for measuring
2. Level surface
3. Measured distance between blade and surface (A)

4. Rotate the same blade 180 degrees so that the opposing cutting edge is now in the same position.

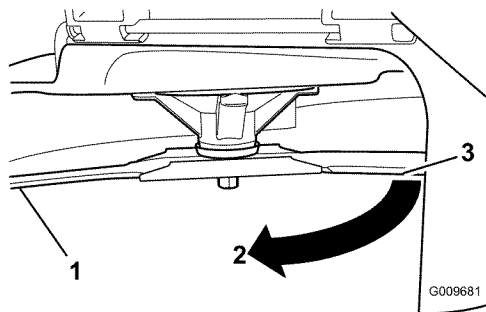

**Figure 41**

1. Blade, side previously measured
2. Measurement position used previously
3. Opposing side of blade being moved into measurement position

5. Measure from the tip of the blade to the flat surface here. The variance should be no more than 1/8 inch (3mm).

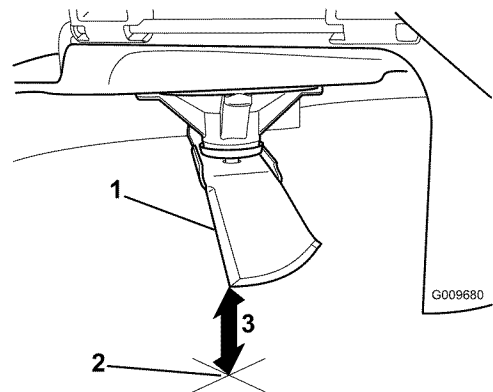

**Figure 42**

1. Opposing blade edge, in position for measuring
2. Level surface
3. Second measured distance between blade and surface (B)



**A blade that is bent or damaged could break apart and could seriously injure or kill you or bystanders.**

- Always replace bent or damaged blade with a new blade.
- Never file or create sharp notches in the edges or surfaces of blade.

A. If the difference between A and B is greater than 1/8 inch (3mm) replace the blade with a new blade. Refer to Removing the Blades and Installing the Blades.

**Note:** If a bent blade is replaced with a new one and the dimension obtained continues to exceed 1/8 inch (3mm), the blade spindle could be bent. Contact an Authorized Toro Dealer for service.

B. If the variance is within constraints, move to the next blade..

Repeat this procedure on each blade.

## Removing the Blades

The blades must be replaced if a solid object is hit, if the blade is out of balance, or the blade is bent. To ensure optimum performance and continued safety conformance of the machine, use genuine Toro replacement blades. Replacement blades made by other manufacturers may result in non-conformance with safety standards.

Hold the blade end using a rag or thickly-padded glove. Remove the blade bolt, curved washer, blade stiffener, and blade from the spindle shaft (Figure 43).

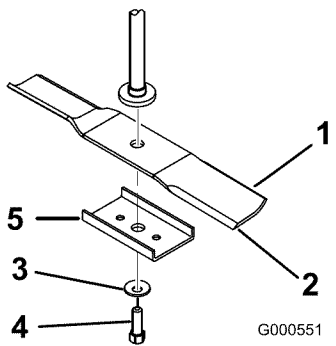

Figure 43

- |                       |                    |
|-----------------------|--------------------|
| 1. Sail area of blade | 4. Blade bolt      |
| 2. Blade              | 5. Blade stiffener |
| 3. Curved washer      |                    |

## Sharpening the Blades

1. Use a file to sharpen the cutting edge at both ends of the blade (Figure 44). Maintain the original angle. The blade retains its balance if the same amount of material is removed from both cutting edges.

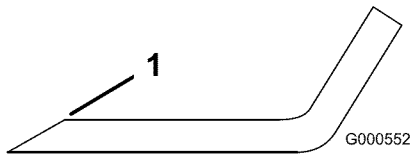

Figure 44

1. Sharpen at original angle
2. Check the balance of the blade by putting it on a blade balancer (Figure 45). If the blade stays in a horizontal position, the blade is balanced and can be used. If the blade is not balanced, file some metal off the end of the sail area only (Figure 44). Repeat this procedure until the blade is balanced.

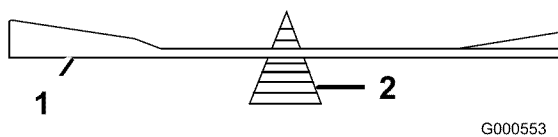

Figure 45

- |          |             |
|----------|-------------|
| 1. Blade | 2. Balancer |
|----------|-------------|

## Installing the Blades

1. Install the blade onto the spindle shaft (Figure 43).

**Important:** The curved part of the blade must be pointing upward toward the inside of the mower to ensure proper cutting.

2. Install the blade stiffener, the curved washer (cupped side toward the blade) and the blade bolt (Figure 43).
3. Torque the blade bolt to 35-65 ft-lb (47-88 N-m).

## Leveling the Mower Deck

Check to ensure the mower deck is level any time you install the mower or when you see an uneven cut on your lawn.

The mower deck must be checked for bent blades prior to leveling; any bent blades must be removed and replaced. Refer to the Checking for Bent Blades procedure before continuing.

The mower deck must be leveled side-to-side first then the front to rear slope can be adjusted.

Requirements:

- The machine must be on a level surface.
- All four tires must be properly inflated. Refer to Checking the Tire Pressure in the Drive System Maintenance section.

## Side-to-Side Leveling

1. Park the machine on a level surface and disengage the blade control switch.
2. Move the motion control levers outward to the park position, stop the engine, remove the key, and wait for all moving parts to stop before leaving the operating position.
3. Set the height-of-cut lever to middle position.
4. Carefully rotate the blades so that they are all side to side (Figure 46 and Figure 47).

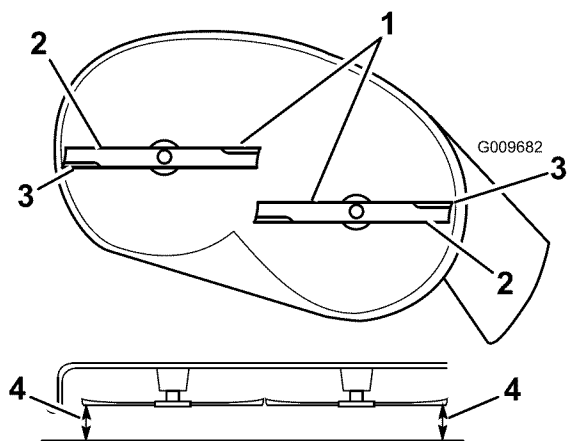
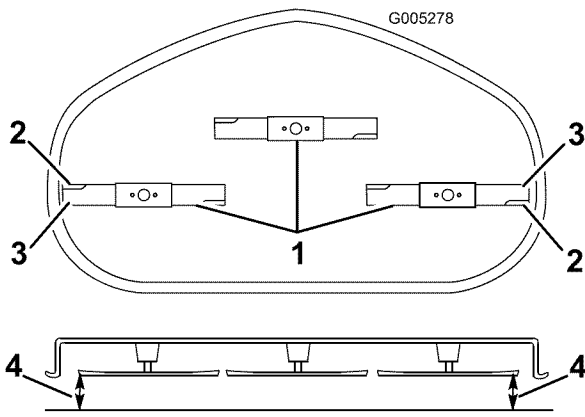

Figure 46

Mower Decks with 2 Blades

- |                        |   |
|------------------------|---|
| 1. Blades side to side | 3. Outside cutting edges                                      |
| 2. Sail area of blade  | 4. Measure from the tip of the blade to the flat surface here |



**Figure 47**  
Mower Decks with 3 Blades

- |                        |   |
|------------------------|---|
| 1. Blades side to side | 3. Outside cutting edges                                      |
| 2. Sail area of blade  | 4. Measure from the tip of the blade to the flat surface here |

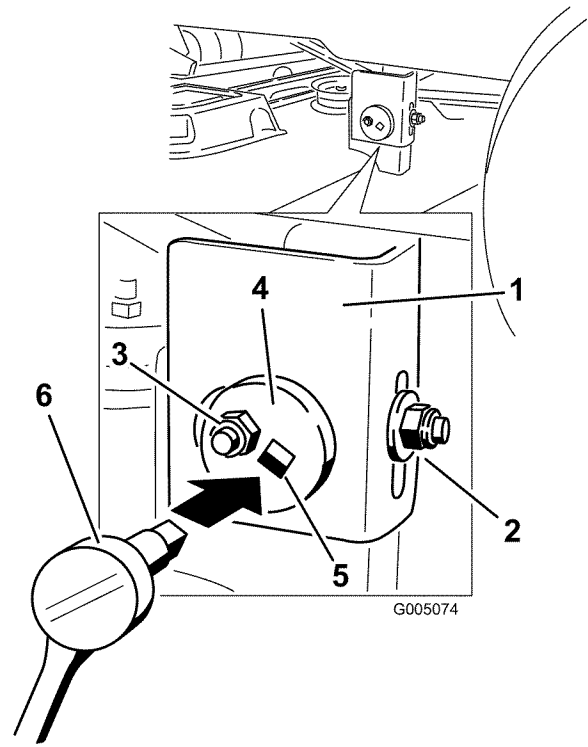

**Figure 48**

- |                     |  |
|---------------------|--|
| 1. Hanger bracket   | 4. Eccentric adjustment plate            |
| 2. Rear locking nut | 5. Socket wrench hole                    |
| 3. Side locking nut | 6. Socket wrench with 3/8 inch extension |

5. Measure between the outside cutting edges and the flat surface (Figure 46 and Figure 47). If both measurements are not within 3/16 inch (5 mm), an adjustment is required; continue with this procedure.
6. Move to the left side of the machine. Loosen, but do not remove, the rear locking nut on the hanger bracket (Figure 48).
7. Loosen the side locking nut on the hanger bracket just enough to allow the eccentric plate to be adjusted (Figure 48). Use a 3/8 inch drive extension on a socket wrench to manipulate the eccentric plate. Use the wrench to reposition the height of the mower deck and adjust to the desired height.
8. Stop the deck at the adjusted position and tighten the side locking nut on the hanger bracket to hold the new position (Figure 48). Tighten the rear locking nut on the hanger bracket.
9. Continue leveling the deck by checking the front-to-rear blade slope; refer to Adjusting the Front-to-Rear Blade Slope.

## Adjusting the Front-to-Rear Blade Slope

Check the front-to-rear blade level any time you install the mower. If the front of the mower is more than 5/16 inch (7.9 mm) lower than the rear of the mower, adjust the blade level using the following instructions:

1. Park the machine on a level surface and disengage the blade control switch.
2. Move the motion control levers outward to the park position, stop the engine, remove the key, and wait for all moving parts to stop before leaving the operating position.
3. Set the height-of-cut lever to middle position.

**Note:** Check and adjust the side-to-side blade level if you have not checked the setting; refer to Side-to-Side Leveling.

4. Carefully rotate the blades so they are facing front to rear (Figure 49 and Figure 50).

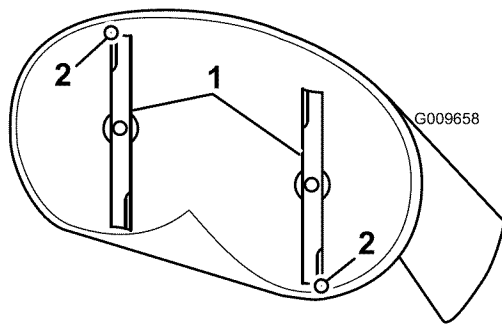

**Figure 49**

**Mower Decks with 2 Blades**

1. Blades front to rear
2. Measure from the tip of the blade to the flat surface here

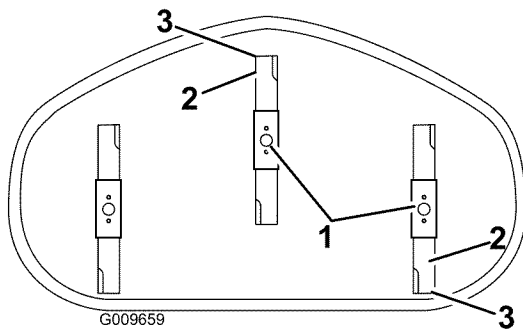
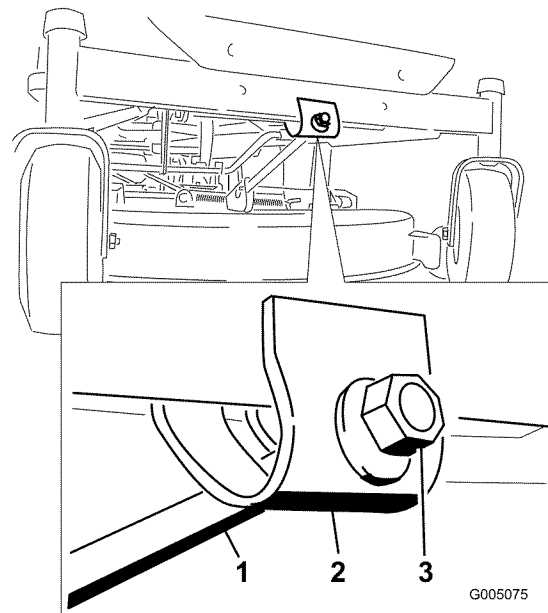

**Figure 50**

**Mower Decks with 3 Blades**

1. Blades front to rear
2. Outside cutting edges
3. Measure from the tip of the blade to the flat surface here

5. Measure from the tip of the front blade to the flat surface and the tip of the rear blade to the flat surface (Figure 49 and Figure 50). If the front blade tip is not 1/16-5/16 inch (1.6-7.9 mm) lower than the rear blade tip, adjust the front locknut.
6. To adjust the front-to-rear blade slope, rotate the adjustment nut in the front of the mower (Figure 51).



**Figure 51**

1. Adjusting rod
2. Adjusting block
3. Lock nut

7. To raise the front of the mower, tighten the adjustment nut. To lower the front of the mower, loosen the adjustment nut.
8. After adjustment, check the front-to-rear slope again. Continue adjusting the nut until the front blade tip is 1/16-5/16 inch (1.6-7.9 mm) lower than the rear blade tip (Figure 49 and Figure 50).
9. When the front-to-rear blade slope is correct check the side-to-side level of the mower again; refer to Leveling the Mower from Side-to-Side.

## Removing the Mower

1. Park the machine on a level surface and disengage the blade control switch.
2. Move the motion control levers outward to the park position, stop the engine, remove the key, and wait for all moving parts to stop before leaving the operating position.
3. Lower the height-of-cut lever to the lowest position.
4. Remove the hairpin cotter and clevis pin from the front support rod (Figure 52). Carefully lower the front of the mower deck to the ground.

# Mower Belt Maintenance

## Inspecting the Belts

**Service Interval:** Every 25 hours—Check the belts for wear/cracks.

Check the belts for cracks, frayed edges, burn marks, or any other damage. Replace damaged belts.

## Replacing the Mower Belt

Squealing when the belt is rotating, blades slipping when cutting grass, frayed belt edges, burn marks, and cracks are signs of a worn mower belt. Replace the mower belt if any of these conditions are evident.

1. Park the machine on a level surface and disengage the blade control switch.
2. Move the motion control levers outward to the park position, stop the engine, remove the key, and wait for all moving parts to stop before leaving the operating position.
3. Set the height-of-cut at the lowest cutting position [1-1/2 inch (38 mm)].
4. Remove the belt covers over the outside spindles.
5. Pull the idler pulley in the direction shown in Figure 55 and roll the belt off of the pulleys.

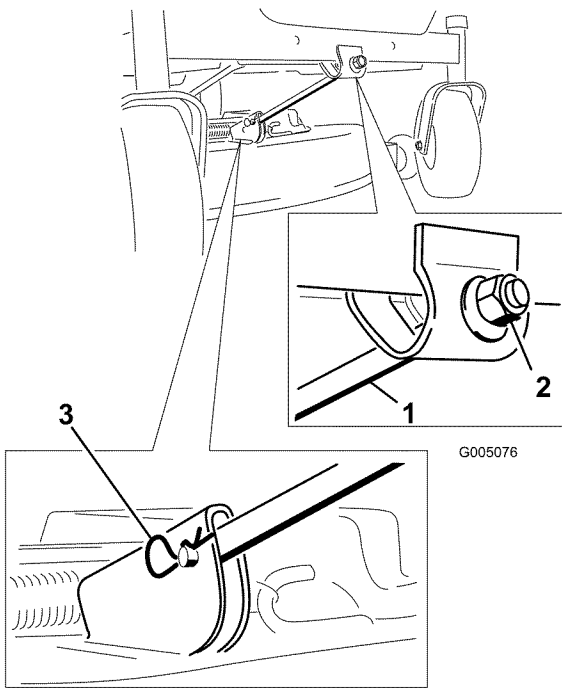

**Figure 52**

1. Front support rod
2. Locking nut
3. Hairpin cotter and clevis pin

5. Lift the mower deck and hanger brackets clear of the rear lift rod and lower the mower carefully to the ground (Figure 53).

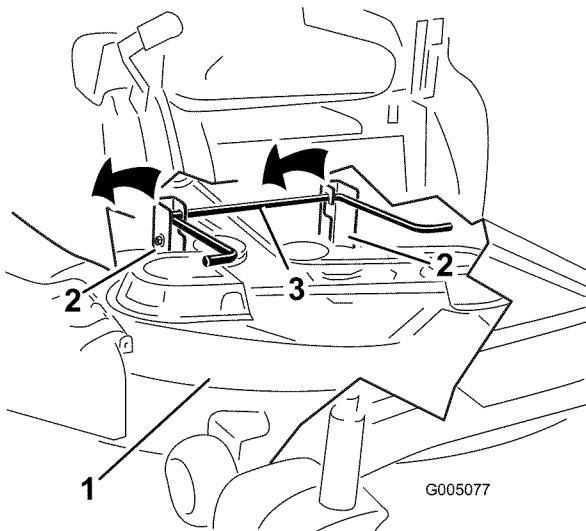

**Figure 53**

1. Mower deck
2. Hanger bracket
3. Rear lift rod

6. Slide the mower deck rearward to remove the mower belt from the engine pulley.
7. Slide the mower deck out from underneath the machine.

**Note:** Retain all parts for future installation.

  
**The spring is under tension when installed and can cause personal injury.**  
**Be careful when removing the belt.**

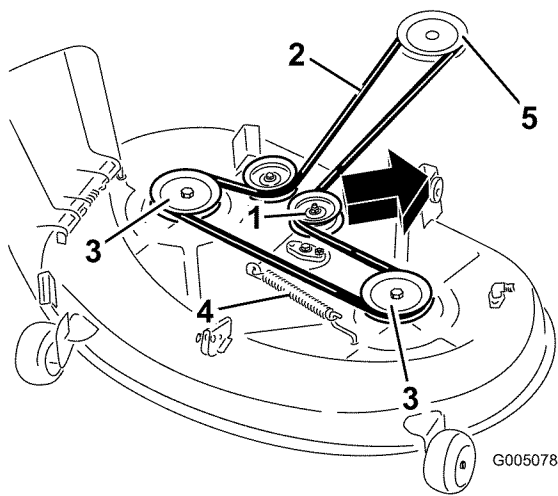

**Figure 54**

Mower Decks with 2 Blades

- |                   |                  |
|-------------------|------------------|
| 1. Idler pulley   | 4. Spring        |
| 2. Mower belt     | 5. Engine pulley |
| 3. Outside pulley |                  |

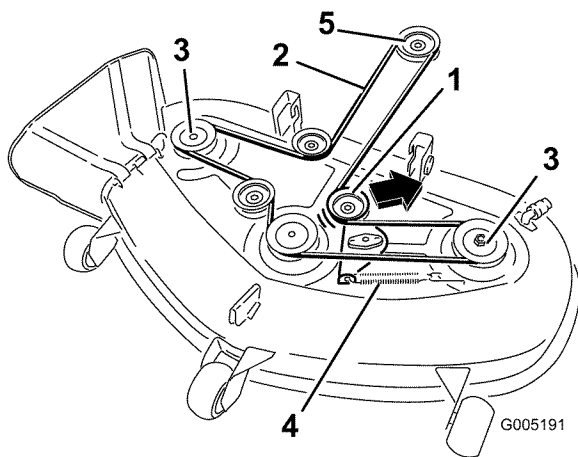

**Figure 55**

Mower Decks with 3 Blades

- |                   |                  |
|-------------------|------------------|
| 1. Idler pulley   | 4. Spring        |
| 2. Mower belt     | 5. Engine pulley |
| 3. Outside pulley |                  |

wait for all moving parts to stop before leaving the operating position.

3. Slide the mower under the machine.
4. Lower the height-of-cut lever to the lowest position.
5. Lift the rear of the mower deck and guide the hanger brackets over the rear lift rod (Figure 53).
6. Attach the front support rod to the mower deck with the clevis pin and hairpin cotter (Figure 52).
7. Install the mower belt onto the engine pulley; refer to Replacing the Mower Belt.

## Replacing the Grass Deflector

**Service Interval:** Before each use or daily—Inspect the grass deflector for damage



An uncovered discharge opening could allow the lawn mower to throw objects in the operator's or bystander's direction and result in serious injury. Also, contact with the blade could occur.

Never operate the machine without grass deflector, discharge cover or grass collection system in place.

Inspect the grass deflector for damage before each use. Replace any damaged parts before use.

1. Locate items shown in Figure 56.

6. Route the new belt around the engine pulley and mower pulleys (Figure 55).
7. Pull the idler pulley in the direction shown in Figure 55 and route the belt onto the idler pulley (Figure 55).
8. Install the belt covers over the outside spindles.

## Installing the Mower

1. Park the machine on a level surface and disengage the blade control switch.
2. Move the motion control levers outward to the park position, stop the engine, remove the key, and



# Cleaning

## Washing the Underside of the Mower

**Service Interval:** Before each use or daily—Clean the mower housing.

Wash the underside of the mower after each use to prevent grass buildup for improved mulch action and clipping dispersal.

1. Park the machine on a level surface and disengage the blade control switch.
2. Move the motion control levers outward to the park position, stop the engine, remove the key, and wait for all moving parts to stop before leaving the operating position.
3. Attach the hose coupling to the end of the mower washout fitting, and turn the water on high (Figure 57).

**Note:** Spread petroleum jelly on the washout fitting O-ring to make the coupling slide on easier and protect the O-ring.

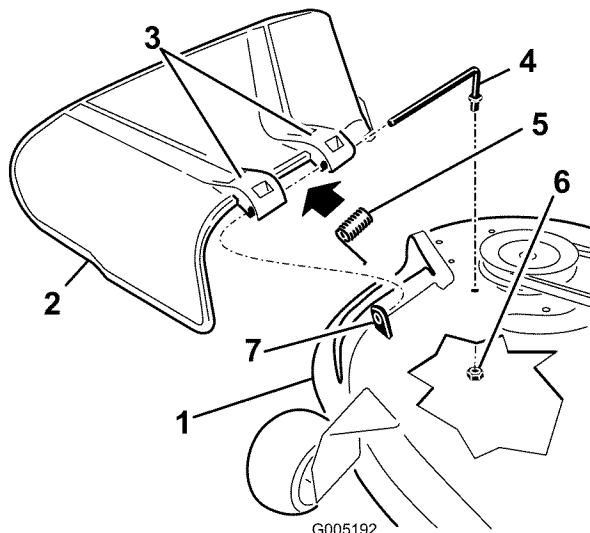
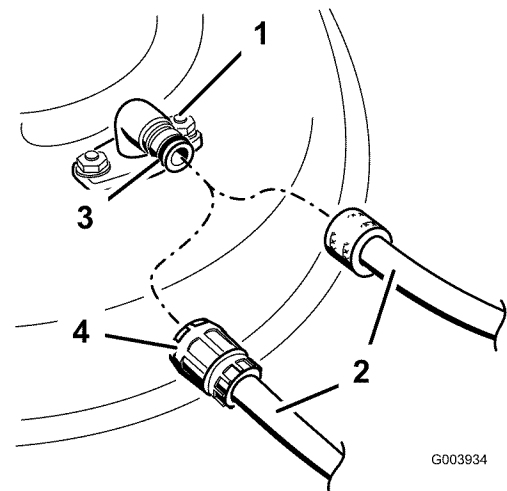

**Figure 56**

- |                            |                    |
|----------------------------|--------------------|
| 1. Mower deck              | 5. Spring          |
| 2. Grass deflector         | 6. Nut (3/8 inch)  |
| 3. Grass deflector bracket | 7. Short stand-off |
| 4. Rod                     |                    |

2. Remove the nut (3/8 inch) from the rod under the mower (Figure 56).
3. Slide the rod out of the short stand-off, spring, and grass deflector (Figure 56). Remove the damaged or worn grass deflector.
4. Replace the grass deflector (Figure 56).
5. Slide rod, straight end, through the rear grass deflector bracket.
6. Place the spring on the rod, with end wires down, and between the grass deflector brackets. Slide rod through second grass deflector bracket (Figure 56).
7. Insert rod at front of grass deflector into short stand-off on deck. Secure rear end of rod into the mower with a nut (3/8 inch) (Figure 56).

**Important:** The grass deflector must be spring loaded in the down position. Lift the deflector up to test that it snaps to the full down position.



**Figure 57**

- |                    |             |
|--------------------|-------------|
| 1. Washout fitting | 3. O-ring   |
| 2. Hose            | 4. Coupling |

4. Lower the mower to the lowest height-of-cut.
5. Sit on the seat and start the engine. Engage the blade control switch and let the mower run for one to three minutes.
6. Disengage the blade control switch, stop the engine, and remove the ignition key. Wait for all moving parts to stop.
7. Turn the water off and remove the coupling from the washout fitting.

**Note:** If the mower is not clean after one washing, soak it and let it stand for 30 minutes. Then repeat the process.

8. Run the mower again for one to three minutes to remove excess water.



**A broken or missing washout fitting could expose you and others to thrown objects or blade contact. Contact with blade or thrown debris can cause injury or death.**

- Replace broken or missing washout fitting immediately, before using mower again.
- Never put your hands or feet under the mower or through openings in the mower.

# Storage

## Cleaning and Storage

1. Disengage the blade control switch, move the motion controls outward to the park position, stop the engine, and remove the key.
2. Remove grass clippings, dirt, and grime from the external parts of the entire machine, especially the engine. Clean dirt and chaff from the outside of the engine cylinder head fins and blower housing.

**Important:** You can wash the machine with mild detergent and water. Do not pressure wash the machine. Avoid excessive use of water, especially near the control panel, engine, hydraulic pumps, and motors.

3. Service the air cleaner; refer to Servicing the Air Cleaner in the Engine Maintenance section.
4. Grease and oil the machine; refer to the Lubrication section.
5. Change the crankcase oil and filter; refer to Servicing the Engine Oil in the Engine Maintenance section.
6. Check the tire pressure; refer to Checking the Tire Pressure in the Drive System Maintenance section.
7. Charge the battery; refer to Servicing the Battery in the Electrical System Maintenance section.
8. Check the condition of the blades; refer to Servicing the Cutting Blades in the Mower Maintenance section.
9. Prepare the machine for storage when non-use occurs over 30 days. Prepare the machine for storage as follows.
10. Add a petroleum based stabilizer/conditioner to the fuel in the tank. Follow the mixing instructions from the stabilizer manufacturer. Do not use an alcohol based stabilizer (ethanol or methanol).

**Note:** A fuel stabilizer/conditioner is most effective when mixed with fresh gasoline and used at all times.

Run the engine to distribute the conditioned fuel through the fuel system (5 minutes).

Stop the engine, allow it to cool, and drain the fuel tank; refer to Draining the Fuel Tank in the Fuel System Maintenance section.

Restart the engine and run it until it stops.

Choke the engine. Start and run the engine until it will not start.

Dispose of fuel properly. Recycle pursuant to local codes.

**Important: Do not store stabilizer/conditioned gasoline over 30 days.**

11. Remove the spark plug(s) and check its condition; refer to Servicing the Spark Plug in the Engine Maintenance section. With the spark plug(s) removed from the engine, pour two tablespoons of engine oil into the spark plug hole. Use the starter to crank the engine and distribute the oil inside the cylinder. Install the spark plug(s). Do not install the wire on the spark plug(s).
12. Clean any dirt and chaff from the top of the mower.
13. Scrape any heavy buildup of grass and dirt from the underside of the mower, then wash the mower with a garden hose.
14. Check the condition of the drive and mower belts.
15. Check and tighten all bolts, nuts, and screws. Repair or replace any part that is worn or damaged.
16. Paint all scratched or bare metal surfaces. Paint is available from your Authorized Service Dealer.
17. Store the machine in a clean, dry garage or storage area. Remove the key from the ignition switch and keep it in a memorable place. Cover the machine to protect it and keep it clean.

# Troubleshooting

Problem	Possible Cause	Corrective Action
The engine overheats.	<ol style="list-style-type: none"> <li>1. The engine load is excessive.</li> <li>2. The oil level in the crankcase is low.</li> <li>3. The cooling fins and air passages under the engine blower housing are plugged.</li> <li>4. The air cleaner is dirty.</li> <li>5. Dirt, water, or stale fuel is in fuel system.</li> </ol>	<ol style="list-style-type: none"> <li>1. Reduce ground speed.</li> <li>2. Add oil to the crankcase.</li> <li>3. Remove the obstruction from the cooling fins and air passages.</li> <li>4. Clean or replace the air cleaner element.</li> <li>5. Contact an Authorized Service Dealer</li> </ol>
The starter does not crank	<ol style="list-style-type: none"> <li>1. The blade control switch is engaged.</li> <li>2. The motion control levers are not in the park position.</li> <li>3. The operator is not seated.</li> <li>4. The battery is dead.</li> <li>5. The electrical connections are corroded or loose.</li> <li>6. A fuse is blown.</li> <li>7. A relay or switch is damaged.</li> </ol>	<ol style="list-style-type: none"> <li>1. Move the blade control switch to Disengaged.</li> <li>2. Move the motion control levers outward to the park position.</li> <li>3. Sit on the seat.</li> <li>4. Charge the battery.</li> <li>5. Check the electrical connections for good contact.</li> <li>6. Replace the fuse.</li> <li>7. Contact an Authorized Service Dealer.</li> </ol>
The engine will not start, starts hard, or fails to keep running.	<ol style="list-style-type: none"> <li>1. The fuel tank is empty.</li> <li>2. The choke is not on.</li> <li>3. The air cleaner is dirty.</li> <li>4. The spark plug wire(s) is loose or disconnected.</li> <li>5. The spark plug(s) is pitted, fouled, or the gap is incorrect.</li> <li>6. There is dirt in fuel filter.</li> <li>7. Dirt, water, or stale fuel is in fuel system.</li> <li>8. There is incorrect fuel in the fuel tank.</li> <li>9. The oil level in the crankcase is low.</li> </ol>	<ol style="list-style-type: none"> <li>1. Fill the fuel tank.</li> <li>2. Move the choke lever to On.</li> <li>3. Clean or replace the air cleaner element.</li> <li>4. Install the wire(s) on the spark plug.</li> <li>5. Install a new, correctly gapped spark plug(s).</li> <li>6. Replace the fuel filter.</li> <li>7. Contact an Authorized Service Dealer.</li> <li>8. Drain the tank and replace the fuel with the proper type.</li> <li>9. Add oil to the crankcase.</li> </ol>
The engine loses power.	<ol style="list-style-type: none"> <li>1. The engine load is excessive.</li> <li>2. The air cleaner is dirty.</li> <li>3. The oil level in the crankcase is low.</li> <li>4. The cooling fins and air passages under the engine blower housing are plugged.</li> <li>5. The spark plug(s) is pitted, fouled, or the gap is incorrect.</li> <li>6. The vent in the fuel cap is closed.</li> <li>7. There is dirt in the fuel filter.</li> <li>8. Dirt, water, or stale fuel is in the fuel system.</li> <li>9. There is incorrect fuel in the fuel tank.</li> </ol>	<ol style="list-style-type: none"> <li>1. Reduce ground speed.</li> <li>2. Clean the air cleaner element.</li> <li>3. Add oil to the crankcase.</li> <li>4. Remove the obstruction from the cooling fins and air passages.</li> <li>5. Install a new, correctly gapped spark plug(s).</li> <li>6. Open the vent in the fuel cap.</li> <li>7. Replace the fuel filter.</li> <li>8. Contact an Authorized Service Dealer.</li> <li>9. Drain the tank and replace the fuel with the proper type.</li> </ol>
The machine does not drive.	<ol style="list-style-type: none"> <li>1. The bypass valves are open</li> <li>2. The traction belts are worn, loose, or broken.</li> <li>3. The traction belts are off of the pulleys.</li> <li>4. The transmission has failed.</li> </ol>	<ol style="list-style-type: none"> <li>1. Close the tow valves.</li> <li>2. Contact an Authorized Service Dealer.</li> <li>3. Contact an Authorized Service Dealer.</li> <li>4. Contact an Authorized Service Dealer.</li> </ol>

Problem	Possible Cause	Corrective Action
There is abnormal vibration.	<ol style="list-style-type: none"> <li>1. The engine mounting bolts are loose.</li> <li>2. The engine pulley, idler pulley, or blade pulley is loose.</li> <li>3. The engine pulley is damaged.</li> <li>4. The cutting blade(s) is/are bent or unbalanced.</li> <li>5. A blade mounting bolt is loose.</li> <li>6. A blade spindle is bent.</li> </ol>	<ol style="list-style-type: none"> <li>1. Tighten the engine mounting bolts.</li> <li>2. Tighten the appropriate pulley.</li> <li>3. Contact an Authorized Service Dealer.</li> <li>4. Install a new cutting blade(s).</li> <li>5. Tighten the blade mounting bolt.</li> <li>6. Contact an Authorized Service Dealer.</li> </ol>
Uneven cutting height.	<ol style="list-style-type: none"> <li>1. The blade(s) is not sharp.</li> <li>2. A cutting blade(s) is/are bent.</li> <li>3. The mower is not level.</li> <li>4. An anti-scalp wheel is not set correctly.</li> <li>5. The underside of the mower is dirty.</li> <li>6. The tire pressure is incorrect.</li> <li>7. A blade spindle is bent.</li> </ol>	<ol style="list-style-type: none"> <li>1. Sharpen the blade(s).</li> <li>2. Install a new cutting blade(s).</li> <li>3. Level the mower from side-to-side and front-to-rear.</li> <li>4. Adjust the anti-scalp wheel height.</li> <li>5. Clean the underside of the mower.</li> <li>6. Adjust the tire pressure.</li> <li>7. Contact an Authorized Service Dealer.</li> </ol>
The blades do not rotate.	<ol style="list-style-type: none"> <li>1. The drive belt is worn, loose or broken.</li> <li>2. The drive belt is off of the pulley.</li> <li>3. The mower belt is worn, loose, or broken.</li> </ol>	<ol style="list-style-type: none"> <li>1. Install a new drive belt.</li> <li>2. Install the drive belt and check the adjusting shafts and belt guides for the correct position.</li> <li>3. Install a new mower belt.</li> </ol>

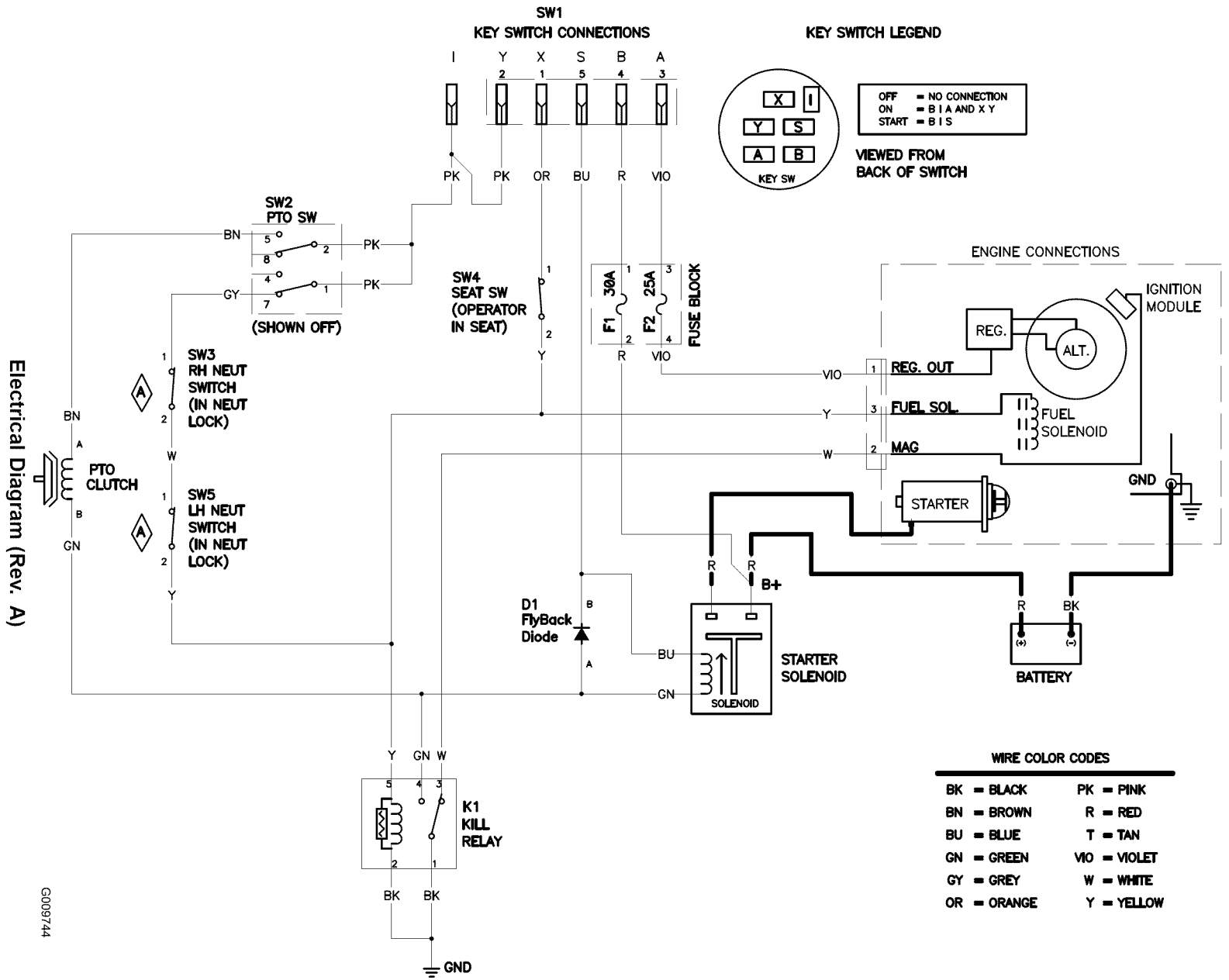

C009744

Electrical Diagram (Rev. A)

**Notes:**



# The Toro Total Coverage Guarantee

A Three-Year Limited Warranty (Limited Warranty for Commercial Use)

TimeCutter  
Z Mowers

## Conditions and Products Covered under The Toro Total Coverage Guarantee

The Toro® Company and its affiliate, Toro Warranty Company, pursuant to an agreement between them, jointly promise to repair any Toro Product used for residential purposes\*, if defective in materials or workmanship or if it stops functioning due to the failure of a component for the period listed below.

This Warranty applies to all TimeCutter Z Mowers and their accessories. This warranty covers the cost of parts and labor, but you must pay transportation costs.

The following time periods apply from the date of purchase:

Products	Warranty Period
TimeCutter Z Mowers	3 years
Attachments (for above units)	3 years
Batteries	1 year

## Limited Warranty for Commercial Use

Gas-powered Toro Products used at more than one location, or used for institutional or rental use, are warranted for 30 days against defects in materials or workmanship, 90 days on engines. Components failing due to normal wear are not covered by this warranty.

## Owner Responsibilities

You must maintain your Toro Product by following the maintenance procedures described in the *Operator's Manual*. Such routine maintenance, whether performed by a dealer or by you, is at your expense.

## Items and Conditions Not Covered

There is no other express warranty except for special emission system coverage and engine warranty coverage on some products. This express warranty does not cover the following:

- Cost of regular maintenance service or parts, such as filters, fuel, lubricants, oil changes, spark plugs, air filters, blade sharpening/worn blade on mowers, cable/linkage adjustments, or brake and clutch adjustments
- Any product or part which has been altered or misused and requires replacement or repair due to accidents or lack of proper maintenance
- Repairs necessary due to improper battery care, failure to use fresh fuel (less than one month old), or failure to properly prepare the unit prior to any period of non-use over one month
- Pickup and delivery charges

## Countries Other than the United States or Canada

Customers who have purchased Toro products exported from the United States or Canada should contact their Toro Distributor (Dealer) to obtain guarantee policies for your country, province, or state. If for any reason you are dissatisfied with your Distributor's service or have difficulty obtaining guarantee information, contact the Toro importer. If all other remedies fail, you may contact us at Toro Warranty Company.

\*Residential purposes means use of the product on the same lot as your home. Use at more than one location, or institutional or rental use, is considered commercial use, and the commercial use warranty would apply.

- Operational misuse, neglect, or accidents
- Repairs or attempted repairs by anyone other than an Authorized Toro Service Dealer

## Instructions for Obtaining Warranty Service

If you think that your Toro Product contains a defect in materials or workmanship, follow this procedure:

1. Contact any Authorized Toro Service Dealer to arrange service at their dealership. To locate a dealer convenient to you, refer to the *Yellow Pages* of your telephone directory (look under "Lawn Mowers") or access our web site at [www.Toro.com](http://www.Toro.com). You may also call the numbers listed in item #3 to use the 24-hour Toro Dealer locator system.
2. Bring the product and your proof of purchase (sales receipt) to the Service Dealer. The dealer will diagnose the problem and determine if it is covered under warranty.
3. If for any reason you are dissatisfied with the Service Dealer's analysis or with the assistance provided, contact us at:

Customer Care Department, Consumer Division  
Toro Warranty Company  
8111 Lyndale Avenue South  
Bloomington, MN 55420-1196  
Toll free at 866-216-6029 (U.S. customers)  
Toll free at 866-216-6030 (Canadian customers)

## General Conditions

All repairs covered by these warranties must be performed by an Authorized Toro Service Dealer using Toro approved replacement parts. Repair by an Authorized Toro Service Dealer is your sole remedy under this warranty.

**Neither The Toro® Company nor Toro Warranty Company is liable for indirect, incidental, or consequential damages in connection with the use of the Toro Products covered by these warranties, including any cost or expense of providing substitute equipment or service during reasonable periods of malfunction or non-use pending completion of repairs under these warranties.**

Some states do not allow exclusions of incidental or consequential damages, so the above exclusions may not apply to you.

This warranty gives you specific legal rights, and you may also have other rights which vary from state to state.