

Model No. 831.153971

Serial No. _____

Write the serial number in the space above for future reference.

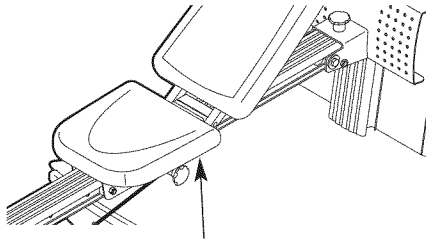

Serial Number Decal (under seat)



Visit our website at

www.weiderplatinum.com

- Assembly
- Adjustments
- Console Operation
- Part List and Drawing

▲ CAUTION

Read all precautions and instructions in this manual before using this equipment. Save this manual for future reference.

W E I D E R[®]

PLATINUM

XP 800

RESISTANCE SYSTEM EXERCISER User's Manual

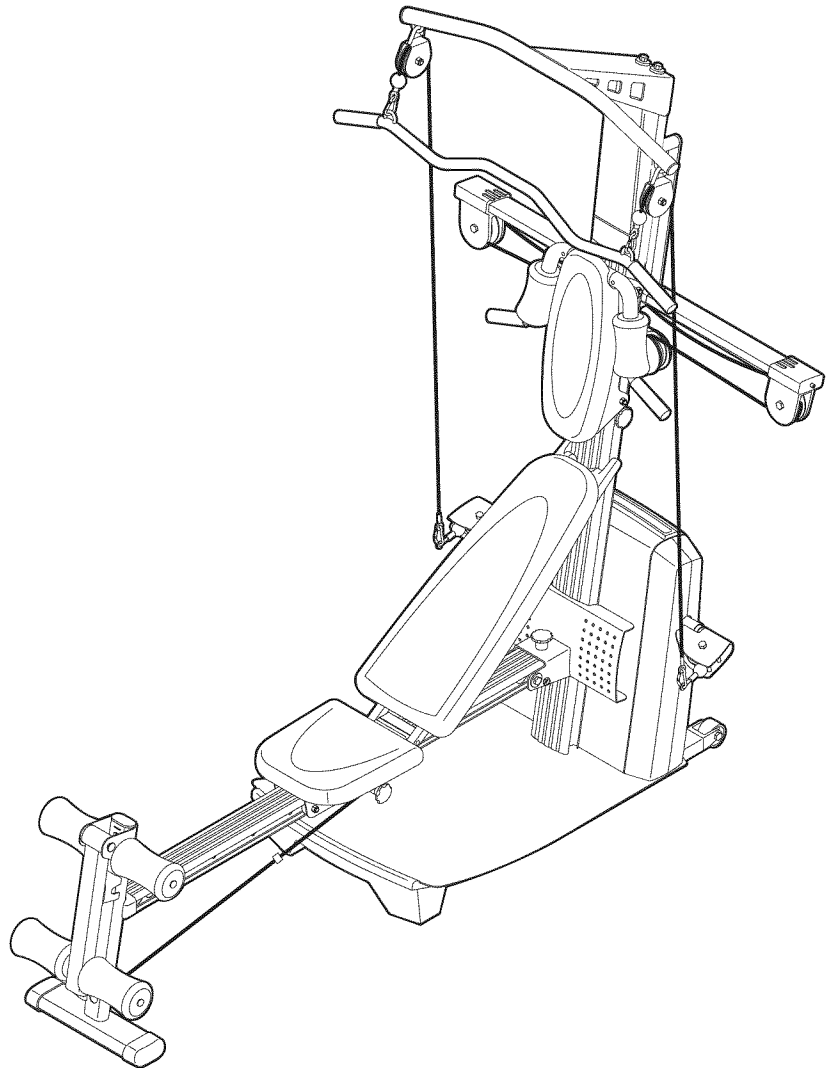

Sears, Roebuck and Co., Hoffman Estates, IL 60179

TABLE OF CONTENTS

WARNING DECAL PLACEMENT	2
IMPORTANT PRECAUTIONS	3
BEFORE YOU BEGIN	4
ASSEMBLY	5
ADJUSTMENTS	14
CONSOLE OPERATION	18
CABLE DIAGRAM	20
TROUBLESHOOTING	21
EXERCISE GUIDELINES	22
ORDERING REPLACEMENT PARTS	Back Cover
FULL TEN-YEAR WARRANTY	Back Cover

Note: A PART IDENTIFICATION CHART and a PART LIST/EXPLODED DRAWING are attached in the center of this manual. Remove the PART IDENTIFICATION CHART and PART LIST/EXPLODED DRAWING before beginning assembly.

WARNING DECAL PLACEMENT

The decals shown here have been placed on the resistance system. If a decal is missing or illegible, please call 1-877-992-5999 to order a free replacement decal. Apply the decal in the location shown.

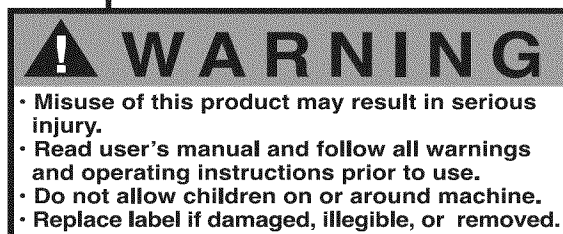
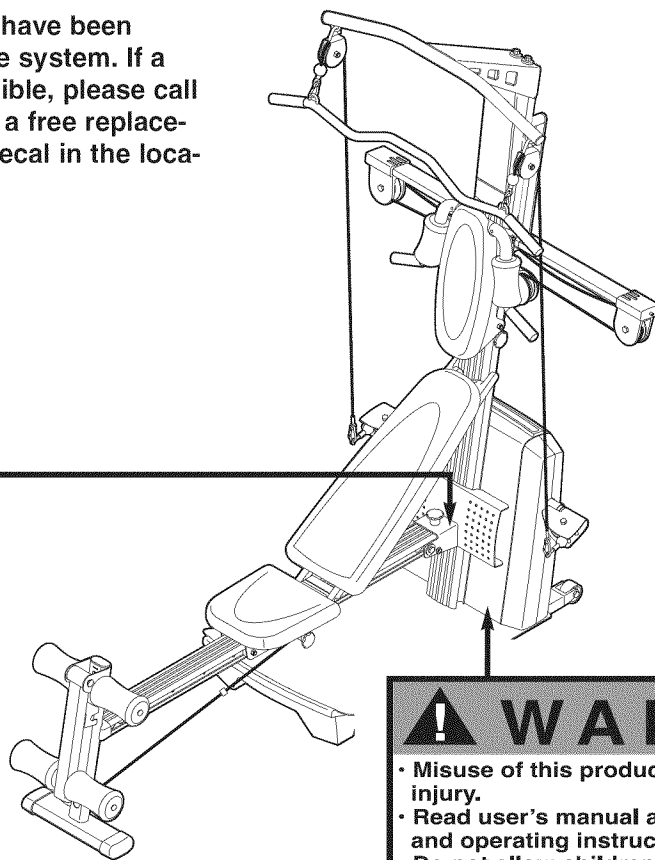

IMPORTANT PRECAUTIONS

⚠ WARNING: To reduce the risk of serious injury, read the following important precautions before using the resistance system.

1. Read all instructions in this manual before using the resistance system. Use the resistance system only as described in this manual.
2. It is the responsibility of the owner to ensure that all users of the resistance system are adequately informed of all precautions.
3. The resistance system is intended for home use only. Do not use the resistance system in any commercial, rental, or institutional setting.
4. Use the resistance system only on a level surface. Cover the floor beneath the resistance system to protect the floor.
5. Make sure that all parts are properly tightened each time the resistance system is used. Replace any worn parts immediately.
6. Keep children under 12 and pets away from the resistance system at all times.
7. Keep hands and feet away from moving parts.
8. Always wear athletic shoes for foot protection while exercising.
9. The resistance system is designed to support a maximum user weight of 300 pounds.
10. The crossbar on the top frame is not designed to be used for pull-up exercises. Do not hang on the crossbar.
11. Pull on the lower cable only while sitting on the bench or standing on the base plate. Pull on the high cables only while sitting on the bench, with the seat in one of the three positions closest to the upright base, or while standing on the base plate.
12. The resistance system is designed to be used with the included resistance. Do not use the resistance system with any other type of resistance.
13. Always disconnect the lat bar from the high cables when performing an exercise that does not require it.
14. Make sure the storage knob is in place and fully tightened each time the resistance system is used.
15. Make sure that the cables remain on the pulleys at all times. If the cables bind as you are exercising, stop immediately and make sure that the cables are on the pulleys.
16. Do not pull on the cables while the resistance level is being adjusted.
17. If you feel pain or dizziness while exercising, stop immediately and begin cooling down.

⚠ WARNING: Before beginning this or any exercise program, consult your physician. This is especially important for persons over the age of 35 or persons with pre-existing health problems. Read all instructions before using. Sears assumes no responsibility for personal injury or property damage sustained by or through the use of this product.

BEFORE YOU BEGIN

Thank you for selecting the innovative WEIDER® PLATINUM XP800 resistance system. The resistance system offers a selection of stations designed to develop every major muscle group of the body. Whether your goal is to tone your body, build dramatic muscle size and strength, or improve your cardiovascular system, the resistance system will help you to achieve the specific results you want.

For your benefit, read this manual carefully before using the resistance system. If you have questions

after reading this manual, call 1-800-4-MY-HOME® (1-800-469-4663). To help us assist you, please note the product model number and serial number before calling. The model number is 831.153971. The serial number can be found on a decal attached to the resistance system (see the front cover of this manual).

Before reading further, please review the drawing below and familiarize yourself with the parts that are labeled.

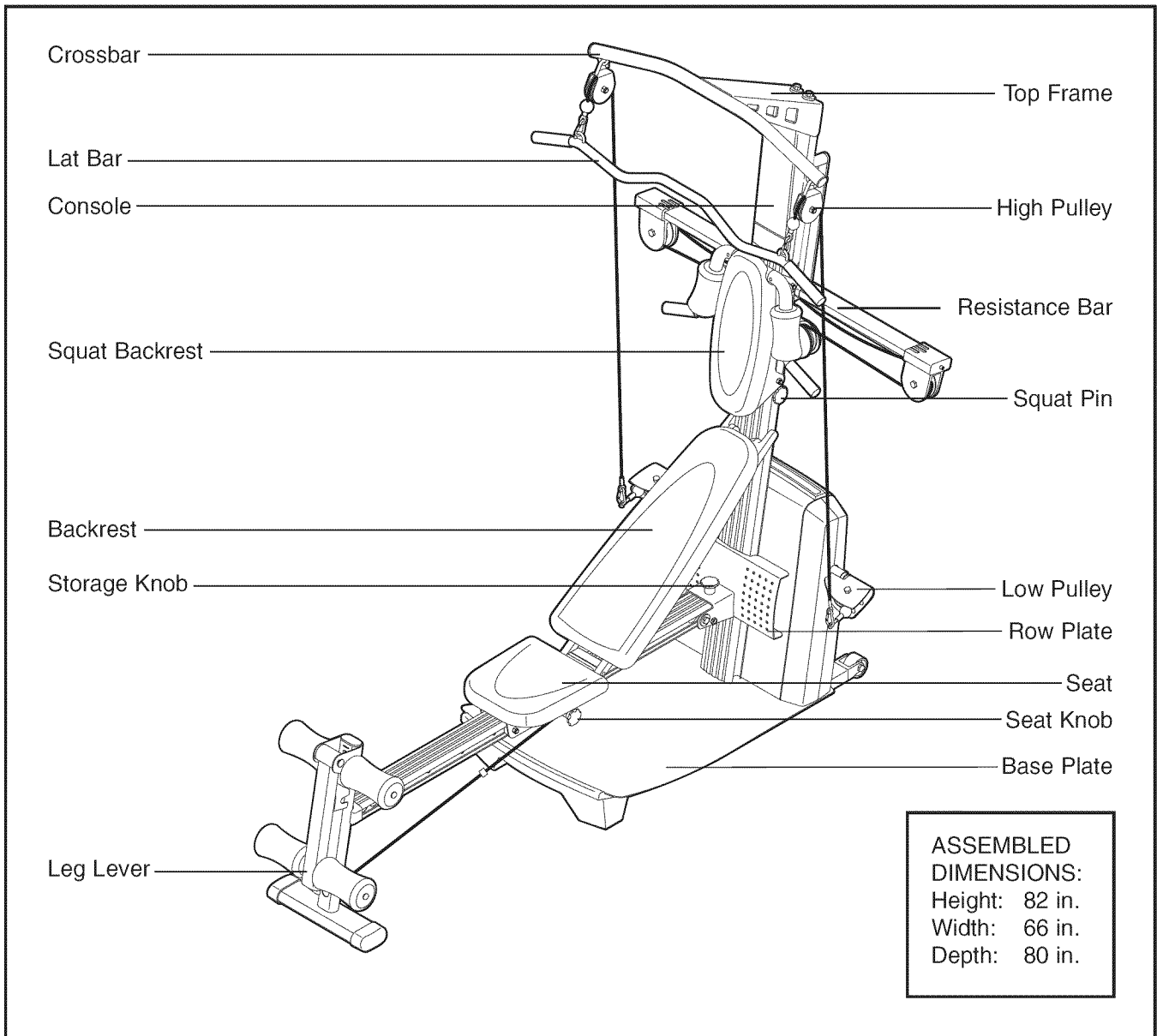

ASSEMBLY

Make Things Easier for Yourself



This manual is designed to ensure that the resistance system can be assembled successfully by most people. However, it is important to realize that the versatile resistance system has many parts and that the assembly process will take time. Most people find that by setting aside plenty of time, assembly will go smoothly.

Before beginning assembly, carefully read the following information and instructions:

- Assembly requires two persons.
- Place all parts in a cleared area and remove the packing materials. Do not dispose of the packing materials until assembly is completed.
- **For help identifying small parts, use the PART IDENTIFICATION CHART.** Note: Some small parts may have been pre-attached for shipping. If a part is not in the parts bag, check to see if it has been pre-attached.

- Tighten all parts as you assemble them, unless instructed to do otherwise.
- As you assemble the resistance system, make sure all parts are oriented as shown in the drawings.

The included Allen wrenches  and the following tools (not included) are required for assembly:

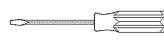
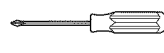
- Two adjustable wrenches 
- One rubber mallet 
- One standard screwdriver 
- One Phillips screwdriver 
- Lubricant, such as grease or petroleum jelly, and soapy water.

Assembly will be more convenient if you have a socket set, a set of open-end or closed-end wrenches, or a set of ratchet wrenches.

1. Before beginning assembly, make sure that you have read and understand the information in the box above. Refer to the PART IDENTIFICATION CHART for help identifying small parts.

Attach the Base Plate Foot (63) to the Base Plate (1) with two M4 x 38mm Screws (100).

2. Attach a Wheel (65) to a Wheel Insert (64) with an M10 x 78mm Button Bolt (99) and an M10 Nylon Locknut (103). **Do not overtighten the Locknut; the Wheel must be able to turn easily.**

Attach the Wheel Insert (64) to the Base Plate (1) with two M4 x 16mm Screws (53) and a Plastic Foot (36).

Attach the other Wheel (65) in the same manner.

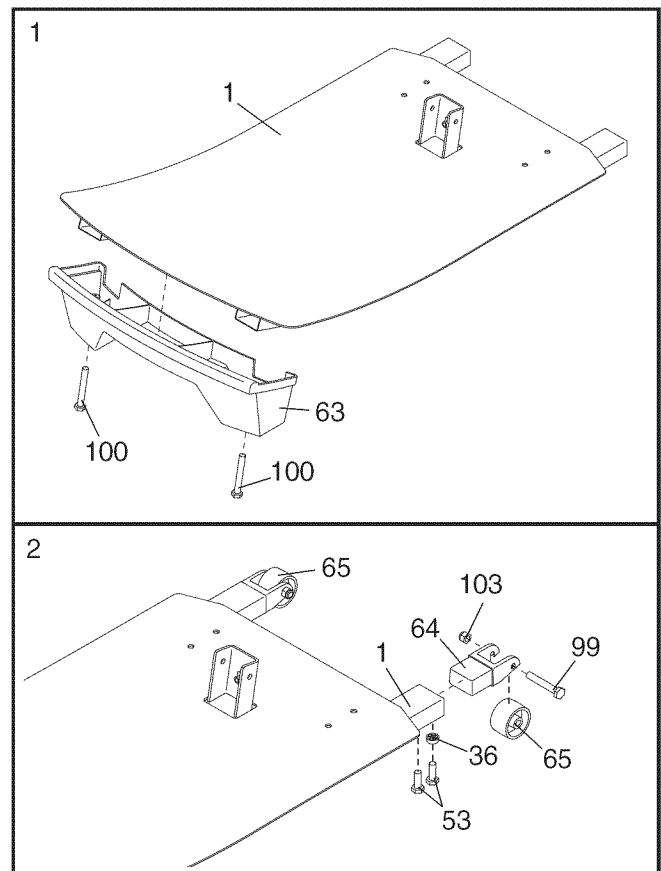

3. Insert the Upper Wire Harness (71) through the hole in the Upright Cover (3). Pull the lower end of the Upper Wire Harness out of the hole in the back of the Upright (2).

Attach the Upright Cover (3) and Upright (2) to the Base Plate (1) with an M10 x 25mm Button Screw (88), an M10 Washer (106), an M10 x 92mm Button Bolt (83), and an M10 Nylon Locknut (103).

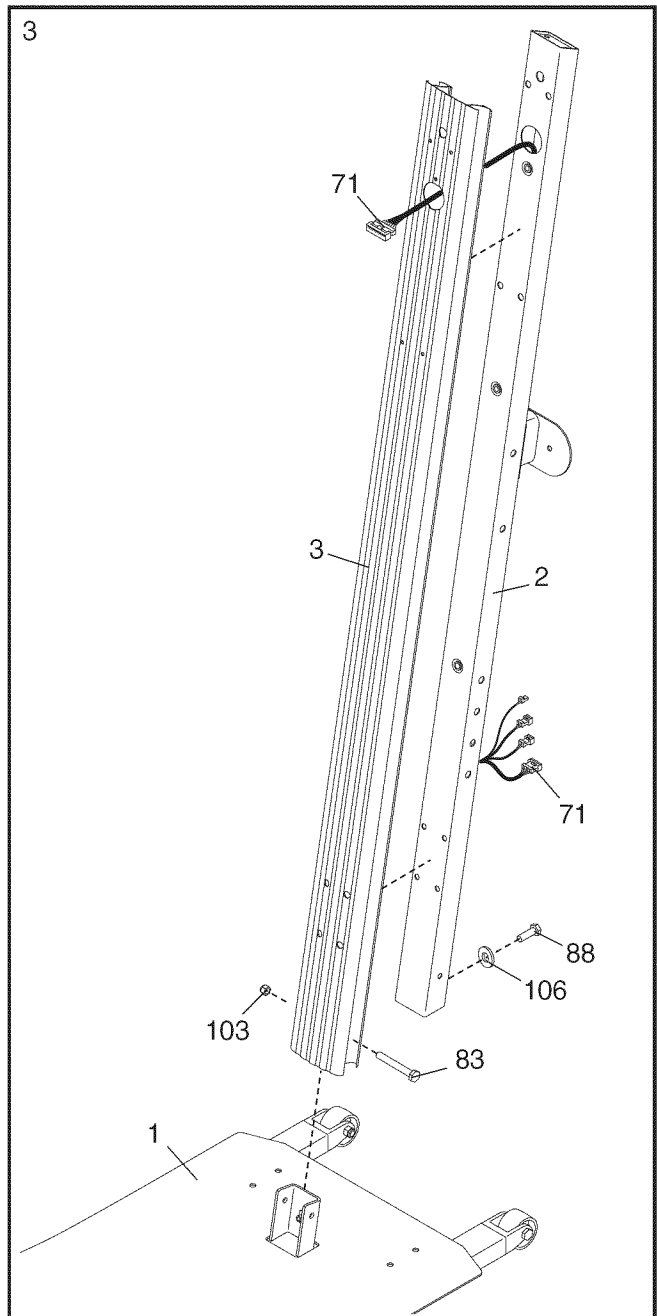

4. Attach the Row Plate (28) to the Upright (2) with four M10 x 75mm Button Bolts (84) and four M10 Nylon Locknuts (103).

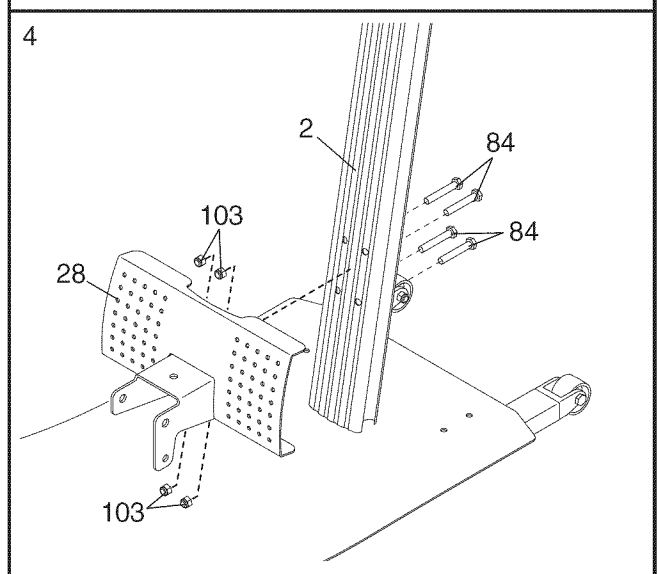

5. Insert the four connectors of the lower wire harness (C) into the sockets of the Upper Wire Harness (71). **The connectors should slide easily into the sockets and snap into place.** If a connector does not slide easily and snap into place, turn the connector over and then insert it.

Make sure that the connectors and wires appear as shown in the inset drawing. **IF THE CONNECTORS ARE NOT INSERTED PROPERLY, THE CONSOLE MAY BE DAMAGED WHEN THE POWER IS TURNED ON.**

Pull the excess lower wire harness (C) out of the Mech Frame (6) and push it and the Upper Wire Harness (71) into the Upright (2).

Insert the Mech Frame (6) into the Base Plate (1). Attach the Mech Frame to the Upright (2) with a 1/2" x 25mm Screw (85) and a 1/2" Lock Washer (12). **Do not tighten the Screw yet.**

Attach the Mech Frame (6) to the Base Plate (1) with four M10 Nylon Locknuts (103).

Tighten the 1/2" x 25mm Screw (85).

6. Attach the Leg Lever Bumper (55) to the Leg (5) with two M5 x 56mm Screws (108).

7. Pull the Seat Knob (48) and remove the Seat Carriage (44) from the Rail (not shown).

Attach the Seat (45) to the Seat Carriage (44) with four M6 x 16mm Screws (41).

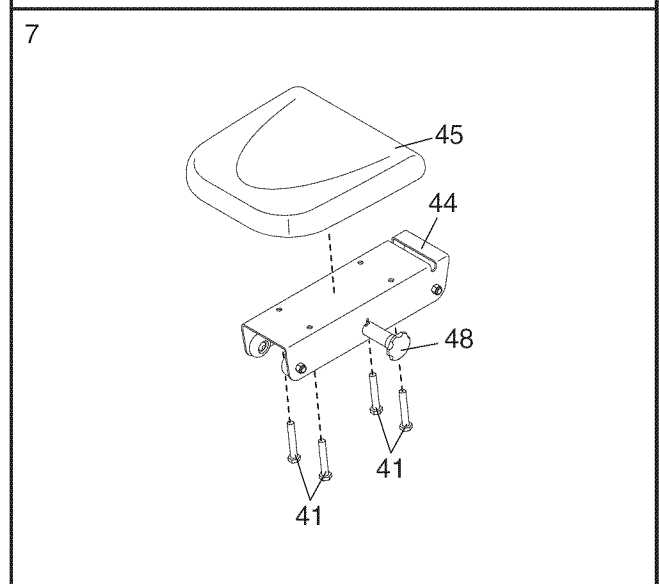
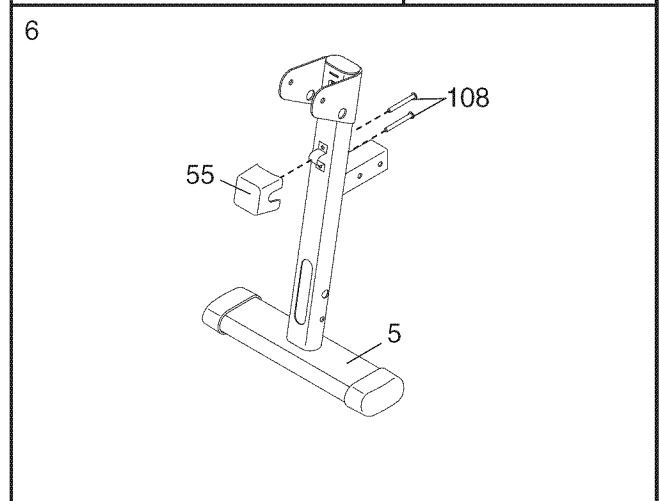
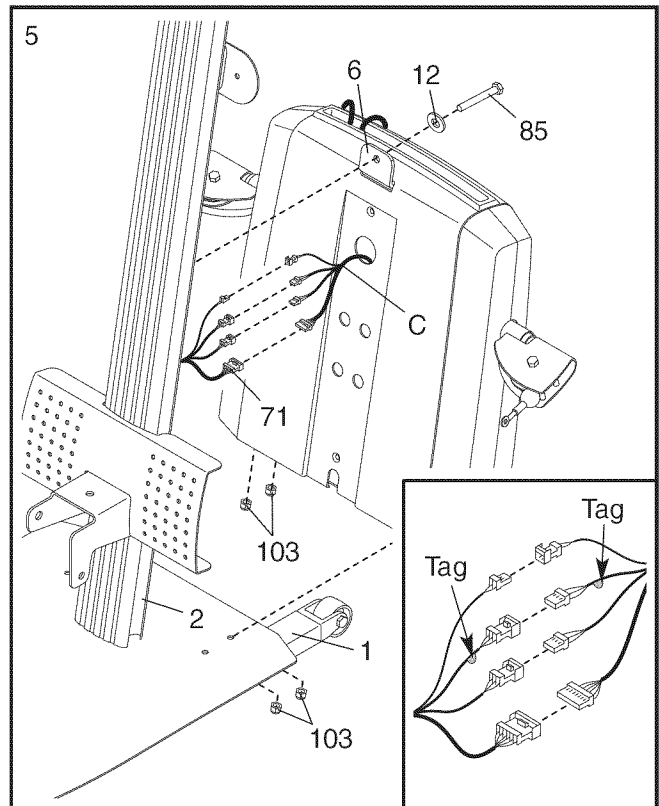

8. Pull the Seat Knob (48) out and slide the Seat Carriage (44) onto the Rail (4) as shown. Engage the Knob into a hole in the Rail.

Press the Rail Cap (49) onto the Leg (5). Attach the Leg to the Rail (4) with two M10 x 64mm Button Bolts (80), four M10 Washers (106), and two M10 Nylon Locknuts (103).

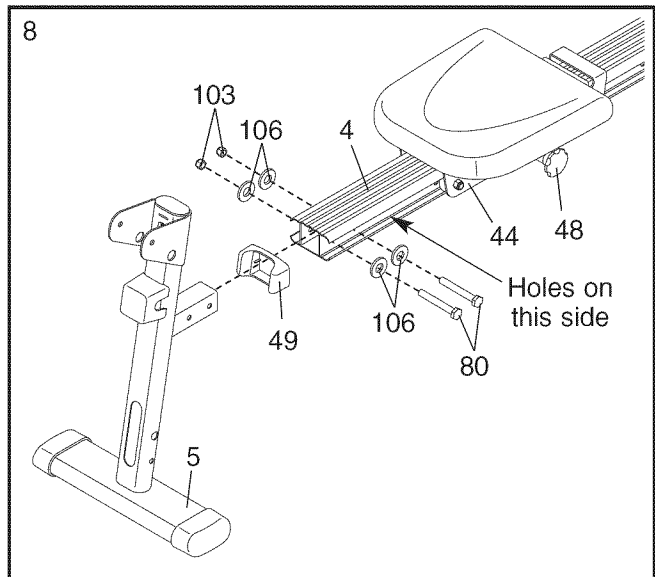

9. Attach the Rail Insert (31) inside of the Rail (4) with two M10 x 64mm Button Bolts (80), four M10 Washers (106), and two M10 Nylon Locknuts (103). **Make sure the Bolts go through the indicated holes in the Rail Insert.**

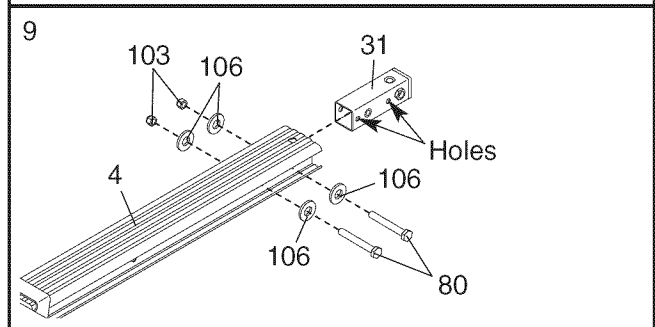

10. Lubricate an M10 x 125mm Button Bolt (89) with grease. Attach the Rail (4) to the Row Plate (28) with the Bolt, two M10 Washers (106), two 31mm Spacers (30), and an M10 Nylon Locknut (103). **Do not overtighten the Locknut; the Rail must be able to pivot easily.**

Tighten the Storage Knob (29) into the Row Plate (28) and the Rail (4).

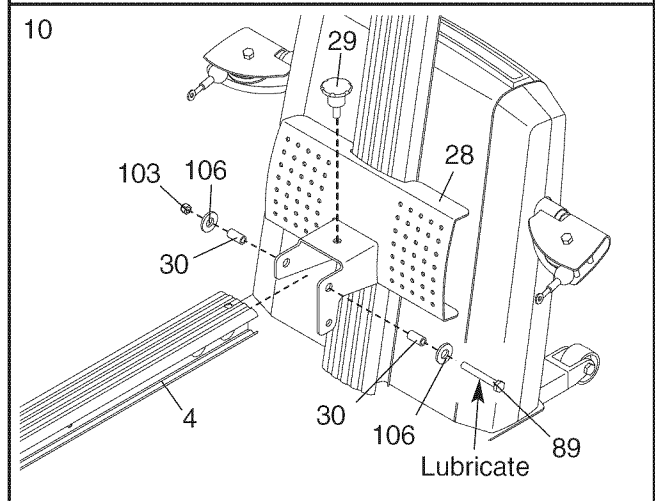

11. Wet a Squat Arm (20) with soapy water. Slide a Small Foam Pad (24) and a Short Handgrip (21) onto the Squat Arm.

Repeat with the other Squat Arm (20).

Tighten the Squat Knob (27) into the Squat Carriage (19) and the Squat Arm Pivot Tube (not shown).

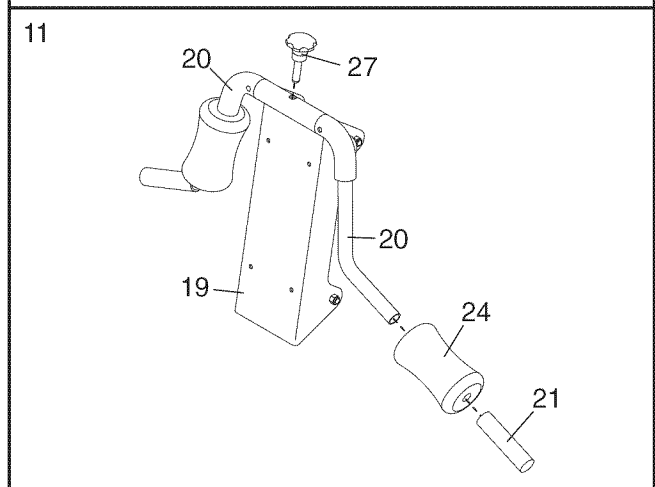

12. Attach the Squat Backrest (25) to the Squat Carriage (19) with four M6 x 16mm Screws (41).

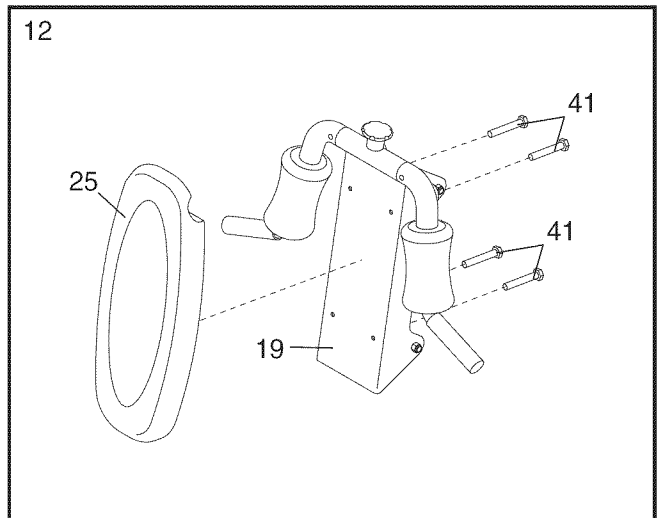

13. Insert the Squat Pin (66) into the Upright (2).
Slide the Squat Carriage (19) onto the Upright (2).

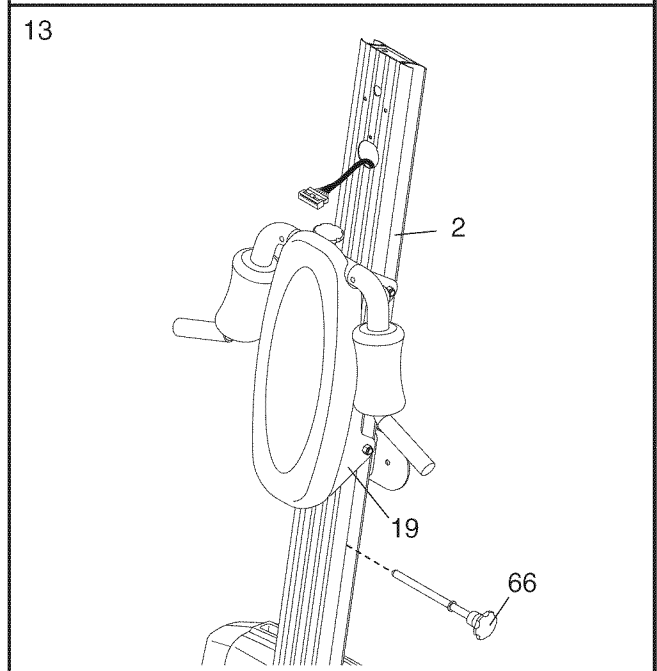

14. Attach the Top Frame (37) to the Upright (2) with two M10 x 25mm Button Screws (88), an M10 x 75mm Button Screw (84), three M10 Lock Washers (75), and an M10 Washer (106).

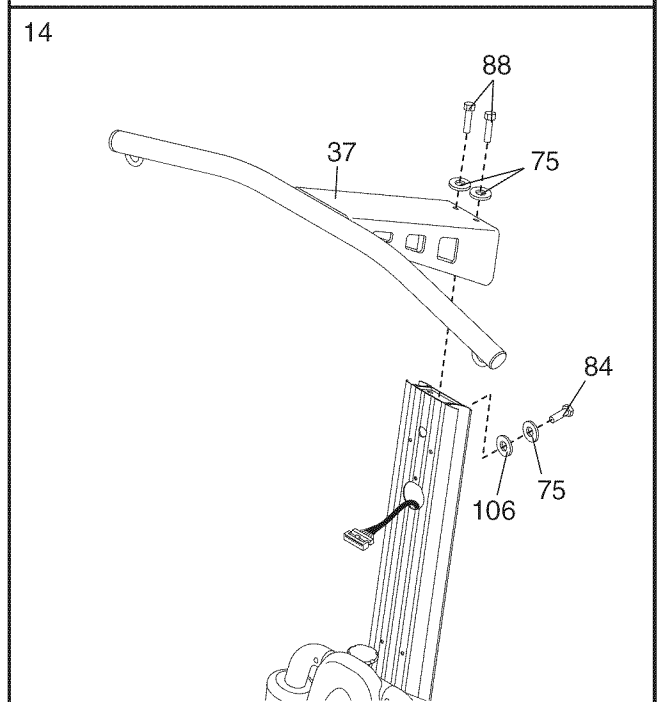

15. Pull the excess Upper Wire Harness (71) out of the Upright (2). Insert the connector on the Console (67) into the socket on the Upper Wire Harness. **The connector should slide easily into the socket and snap into place.** If the connector does not slide easily and snap into place, turn the connector over and then insert it.

Make sure that the connector and wires appear as shown in the inset drawing. **IF THE CONNECTOR IS NOT INSERTED PROPERLY, THE CONSOLE MAY BE DAMAGED WHEN THE POWER IS TURNED ON.**

Push the excess Upper Wire Harness (71) into the Upright (2).

Attach the Console (67) to the Upright (2) with four M4 x 70mm Screws (114).

16. Attach a Large Pulley (14) and the Pulley Plate (68) to the Upright (2) with an M12 x 62mm Button Bolt (81) and an M12 Nylon Locknut (43). **Do not tighten the Locknut yet.**

17. Pull the upper cable (A), which is attached inside of the Mech Frame (not shown), up between the Upright (2) and the Pulley Plate (68).

Attach another Large Pulley (14) to the Upright (2) and Pulley Plate (68) with an M12 x 62mm Button Bolt (81) and an M12 Nylon Locknut (43). **Make sure that the upper cable (A) is between the two Pulleys.**

Hold the 38mm Spacer (90) inside the loop of the upper cable (A), and between the Upright (2) and the Pulley Plate (68). Attach the Spacer with an M10 x 58mm Button Screw (42). **Make sure the ends of the cable do not wrap around each other below the Spacer and the Large Pulleys (14) used in steps 16 and 17 (refer to the CABLE DIAGRAM on page 20).**

Tighten the M12 Nylon Locknuts (43) used in steps 16 and 17.

18. Attach a Small Guide Spacer (18), a Large Guide Spacer (17), and two Bar Guides (15) to the Upright (2) with an M10 x 152mm Bolt (86).

Pull the upper cable (A) up between the Bar Guides (15). Press the metal cover on the cable into the groove in the Block Spacer (16). Attach a Small Guide Spacer (18), the Block Spacer, the two Bar Guides (15), an M10 Thick Washer (54), and the two Tethers (70) to the Upright (2) with another M10 x 152mm Bolt (86). **Do not tighten the Bolt yet.**

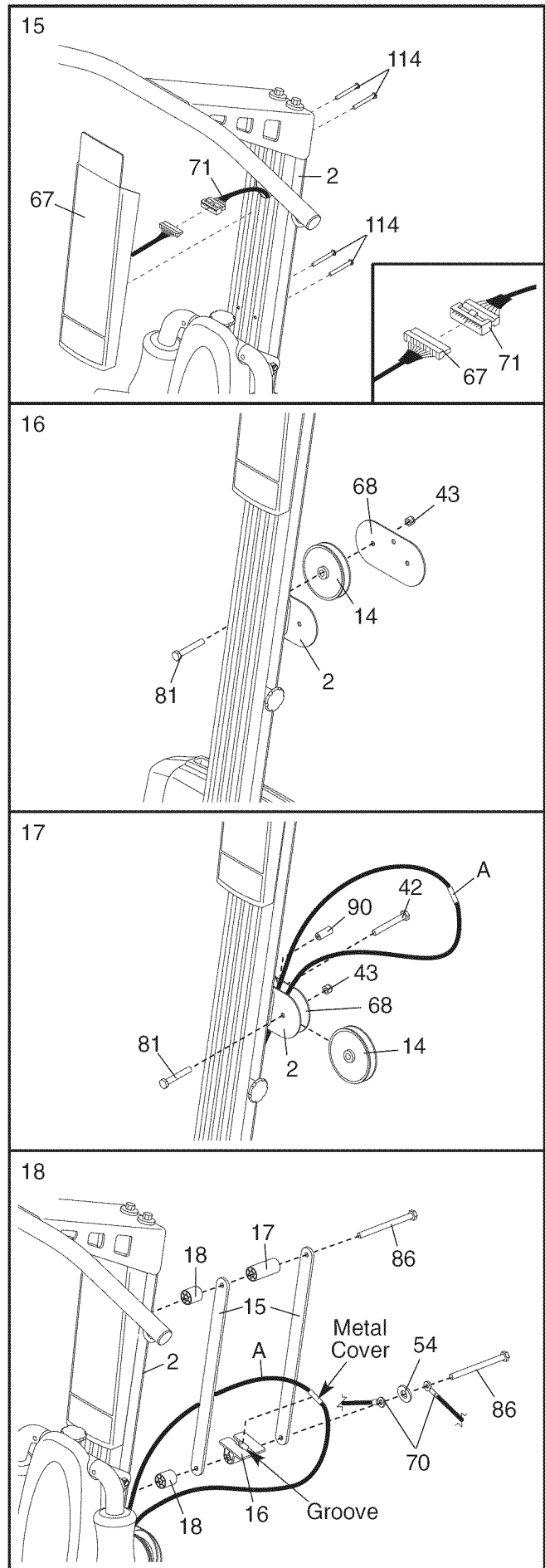

19. Insert the Resistance Bar (9) between the Bar Guides (15), and center it on the Block Spacer (not shown).

Remove the paper backing from a Bracket Plate (11) and stick it to the end of Resistance Bar (9). Press a Pulley Bracket (10) onto the Resistance Bar. Screw a 3/8" x 38mm Tension Screw (13) into the Pulley Bracket a couple of turns. **Make sure the hexagonal hole in the Screw is on the outside of the Bracket.**

Attach a Tether (70) to the Pulley Bracket (10) at the upper hole, with an M10 x 64mm Button Bolt (80), an M10 Thick Washer (54), and an M10 Nylon Locknut (103).

Repeat on the other side of the Resistance Bar (9). Then, tighten the lower M10 x 152mm Bolt (86) used in step 18.

20. Hold a Large Pulley (14) inside the upper cable (A). Attach the Pulley to a Pulley Bracket (10) with an M12 x 58mm Button Bolt (87) and an M12 Nylon Locknut (43). **Make sure that the cable is routed as shown in the CABLE DIAGRAM on page 20.**

21. Hold a Large Pulley (14) inside the upper cable (A). Attach the Pulley to the other Pulley Bracket (10) with an M12 x 58mm Button Bolt (87) and an M12 Nylon Locknut (43). **Make sure that the cable is routed as shown in the CABLE DIAGRAM on page 20.**

Tighten the two 3/8" x 38mm Tension Screws (13) an equal number of turns until the upper cable (A) is tight.

22. Attach a Plastic Foot (36) to the Backrest Frame (32) with an M4 x 16mm Screw (53).

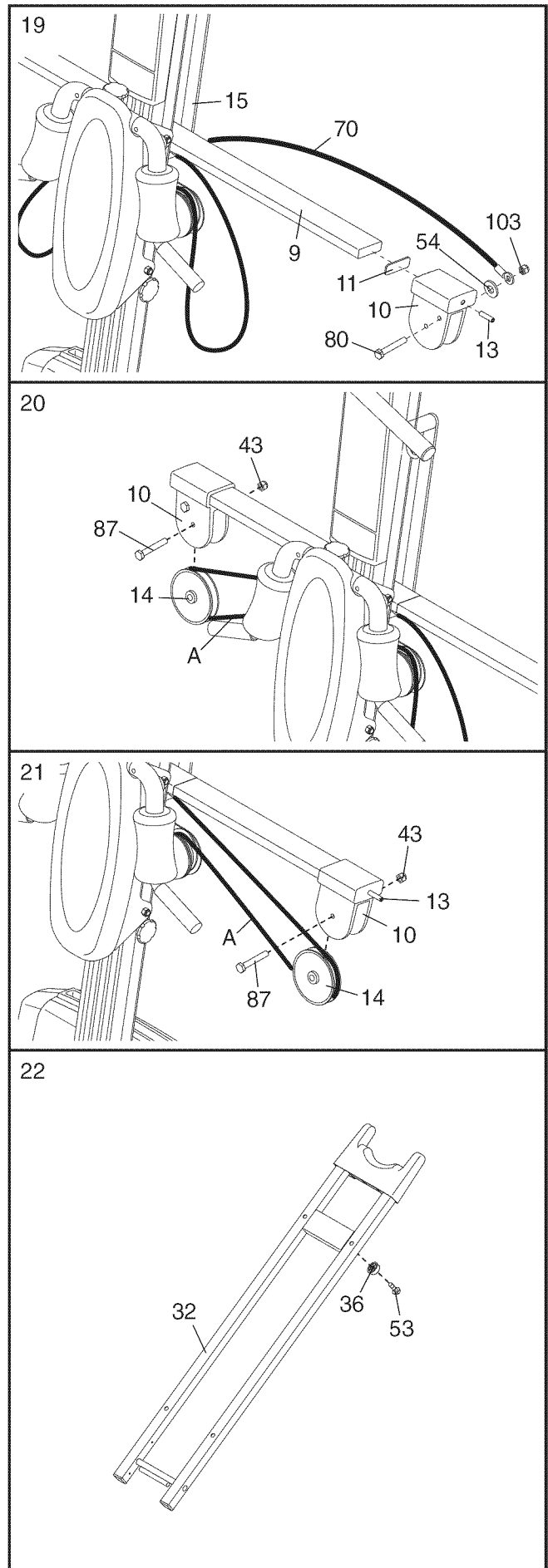

23. Attach the Backrest (35) to the Backrest Frame (32) with four M6 x 38mm Screws (105) and four M6 Washers (107).

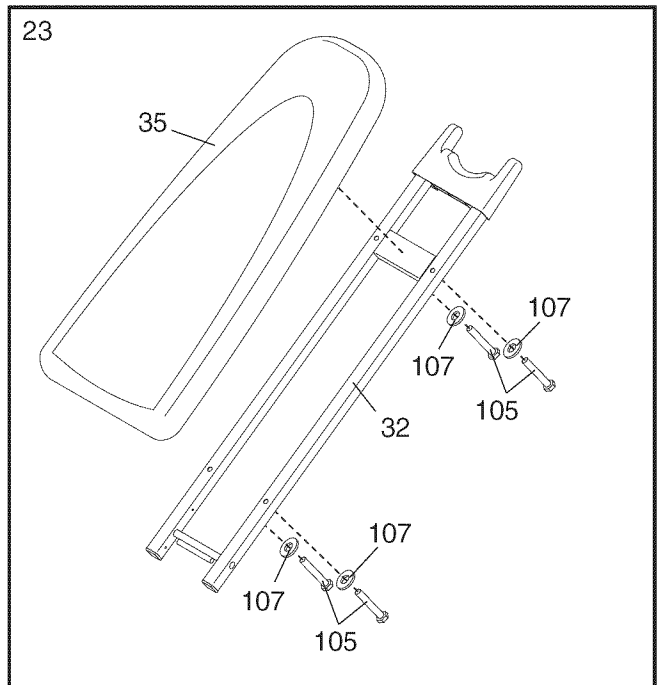

24. Insert the rod on the Backrest Frame (32) into the slot in the Seat Carriage (44). **Hold the Backrest Frame vertically over the Seat Carriage and slide the rod into the slot, as shown in the inset drawing.**

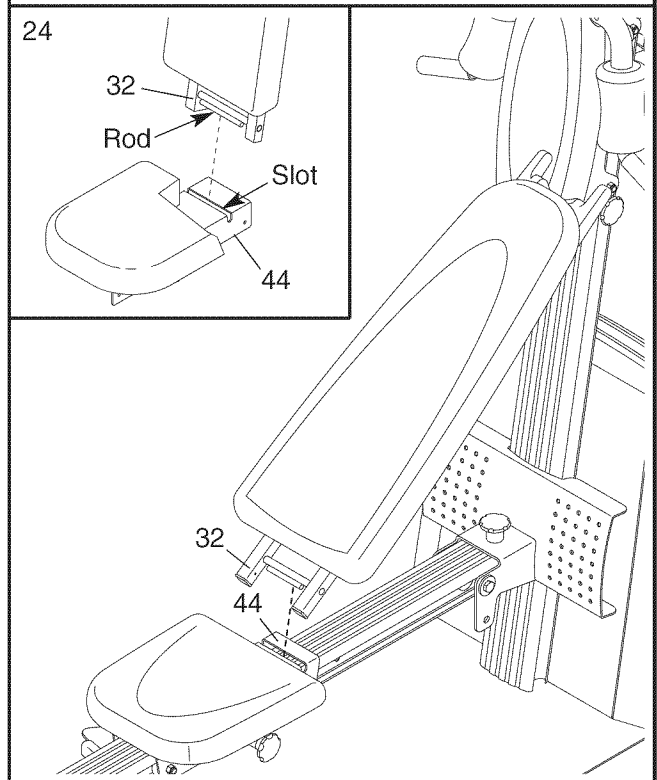

25. Attach the Leg Lever (56) to the Leg (5) with a Leg Station Pin (60). Slide a Cotter Pin (113) onto the Leg Station Pin.

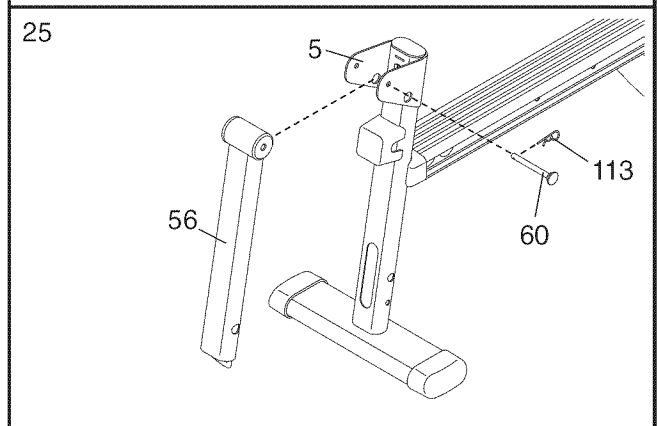

26. Slide the Pad Tube (50) into the Leg Lever (56). Slide two Large Foam Pads (52) onto the Pad Tube.

Attach the other Pad Tube (50) to the Leg Lever (56) and the Leg (5) in the same manner.

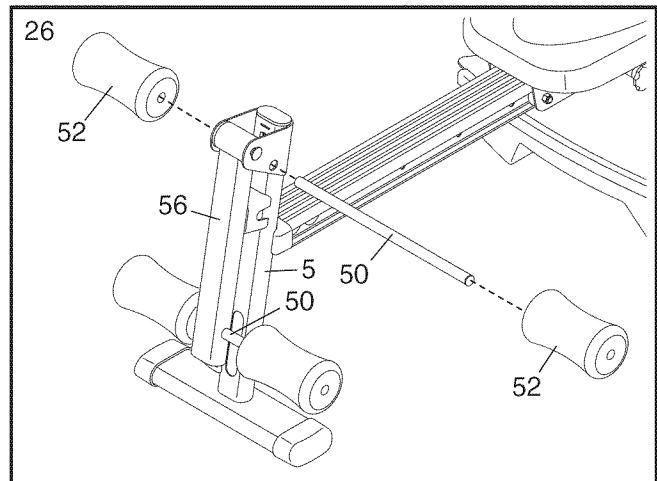

27. Attach a 90mm Pulley (40) inside of the Leg (5) with an M10 x 85mm Button Bolt (92), two M10 Washers (106), two 22mm Spacers (61), and an M10 Nylon Locknut (103).

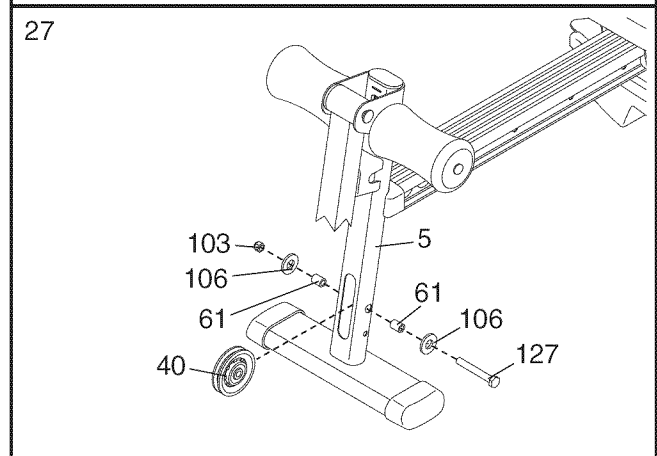

28. Wrap a High Cable (101) over a 90mm Pulley (40). Attach the Pulley to a Pulley Housing (39) with an M10 x 44mm Button Bolt (93) and an M10 Nylon Locknut (103).

Repeat this step with the other High Cable (101) and Pulley Housing (39).

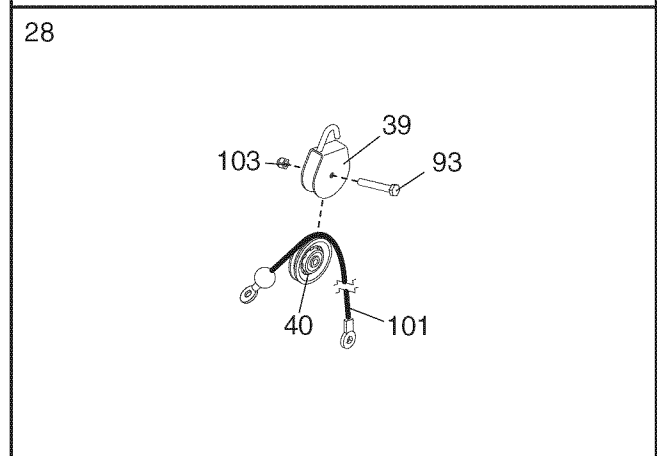

29. Make sure that all parts have been properly tightened. The use of the remaining parts will be explained in ADJUSTMENTS, beginning on the following page.

Before using the resistance system, turn on the console and change the resistance setting as described in CONSOLE OPERATION on page 18. Refer to TROUBLESHOOTING on page 21 and adjust the Crossbar Cable tension as described.

ADJUSTMENTS

This section explains how to adjust the resistance system. See the EXERCISE GUIDELINES on page 22 for important information about how to get the most benefit from your exercise program. Also, refer to the accompanying exercise guide to see the correct form for each exercise.

Make sure all parts are properly tightened each time the resistance system is used. Replace worn parts immediately. The resistance system can be cleaned with a damp cloth and a mild, non-abrasive detergent. Do not use solvents. The resistance bar can be cleaned with a vinyl and rubber protectant, available at an automotive or department store.

ATTACHING THE HIGH PULLEYS

To use a high pulley, slide the hook on the Pulley Housing (39) onto an hook on the Top Frame (37). Attach the end of the High Cable (101) without the ball to the end of the lower cable (B) with a Cable Clip (94). **Attach the other high pulley in the same manner.**

Remove the high pulleys when not in use.

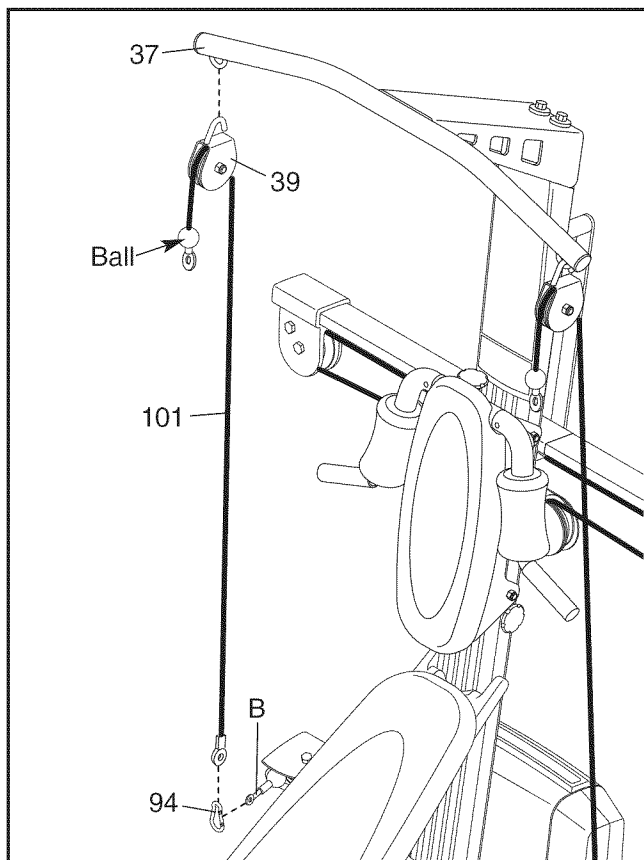

USING THE LEG LEVER

To use the Leg Lever (56), attach it to the Leg (5) with a Leg Station Pin (60). Slide a Cotter Pin (113) onto the Leg Station Pin.

Route the hook end of the Leg Lever Cable (102) under the 90mm Pulley (40) in the Leg (5), and attach it to the Leg Lever (56). **Make sure the hook is oriented as shown when attaching it to the Leg Lever.** Insert a Leg Station Pin (60) into the Leg, under the Cable. Slide a Cotter Pin (113) onto the Leg Station Pin.

See the inset drawing. Attach a long end of the Leg Lever Cable (102) to one end of the lower cable (B) with a Cable Clip (94). **Attach the other long end of the Leg Lever Cable to the other end of the low cable in the same manner.**

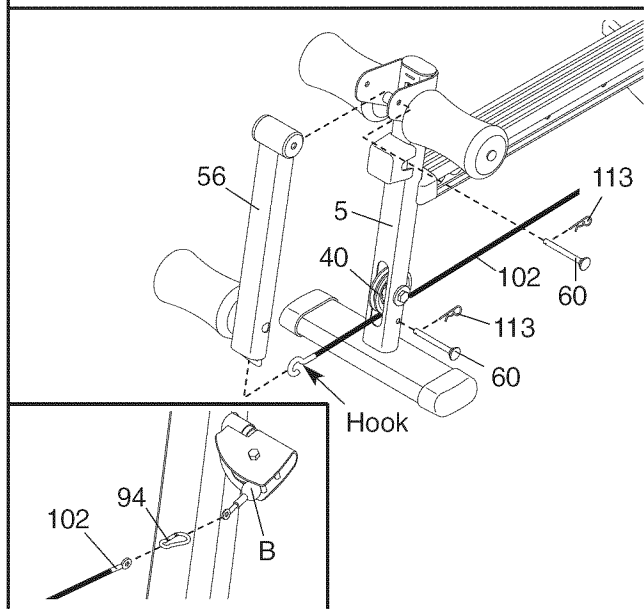

ADJUSTING THE SQUAT ARM

To adjust the Squat Arm (20), remove the Squat Knob (27) from Squat Carriage (19). Move the Arm to the up or down position, and reengage the Knob into the Squat Carriage.

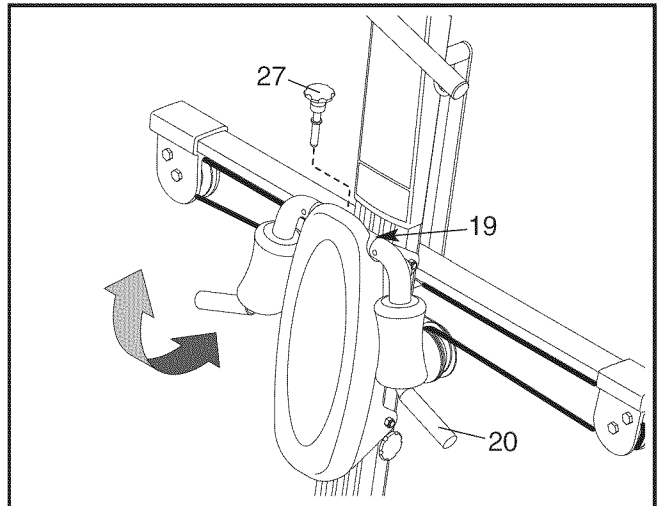

ATTACHING THE SQUAT STATION

To use the squat station, first remove the backrest (see ADJUSTING THE BACKREST below). Next, adjust the squat arm to the up position (see ADJUSTING THE SQUAT ARM above). Then, insert a Squat Pin (66) into the correct hole in the Upright (2). Finally, attach each end of the lower cable (B) to the Squat Carriage (19) with a Carriage Strap (77) and two Cable Clips (94).

Note: The Squat Pin (66) will determine the lowest point to which the Squat Carriage (19) can descend. The Squat Carriage should not be able to descend so low that the user could become trapped under the Squat Arm (20).

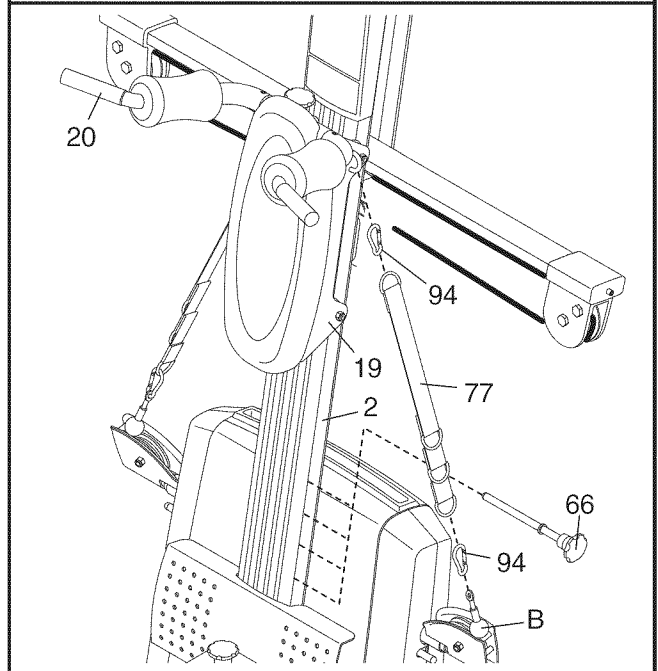

ADJUSTING THE BACKREST

The Backrest (35) can be used in a level position or an inclined position. To use the Backrest in a level position, secure the Seat Carriage (44) at the adjustment hole in the Rail (4) closest to the Leg (not shown) (see ADJUSTING THE SEAT on page 16).

To use the Backrest (35) in an inclined position, secure the Seat Carriage (44) at one of the other adjustment holes in the Rail (4). Rest the Backrest against the Upright (2).

For row exercises, remove the Backrest (35) from the Seat Carriage (44). Hold the Backrest vertically over the Seat Carriage and lift the rod out of the slot (see the inset drawing).

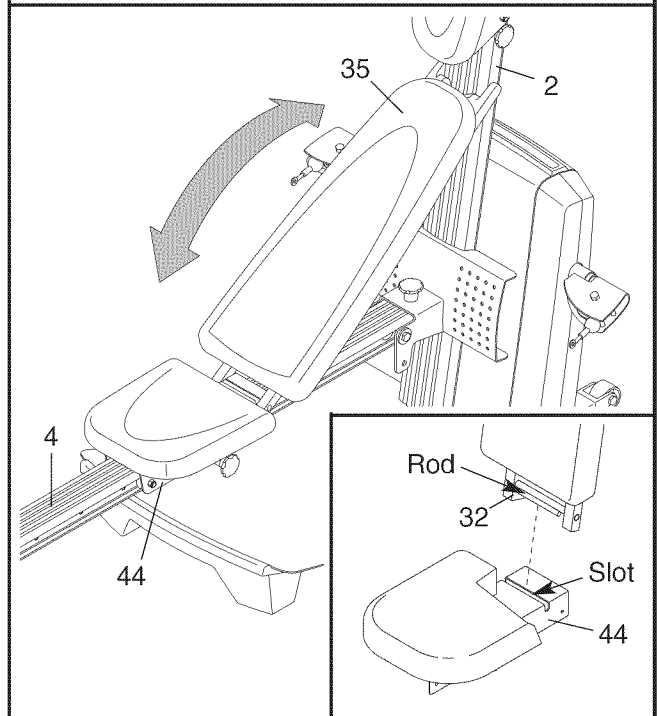

ATTACHING THE ACCESSORIES

To attach the Lat Bar (82) to the high pulleys, first attach the high pulley to the resistance system (see ATTACHING THE HIGH PULLEYS on page 14). Then, attach the Lat Bar to a High Cable (101) with a Cable Clip (94). **Attach the Lat Bar to the other High Cable in the same manner.**

The Handles (not shown) and the Ankle Strap (not shown) can be attached to the High Cables (101) or the lower cable (not shown) with Cable Clips (94). Attach the Hip Strap (not shown) to the ends of the lower cable with two Cable Clips.

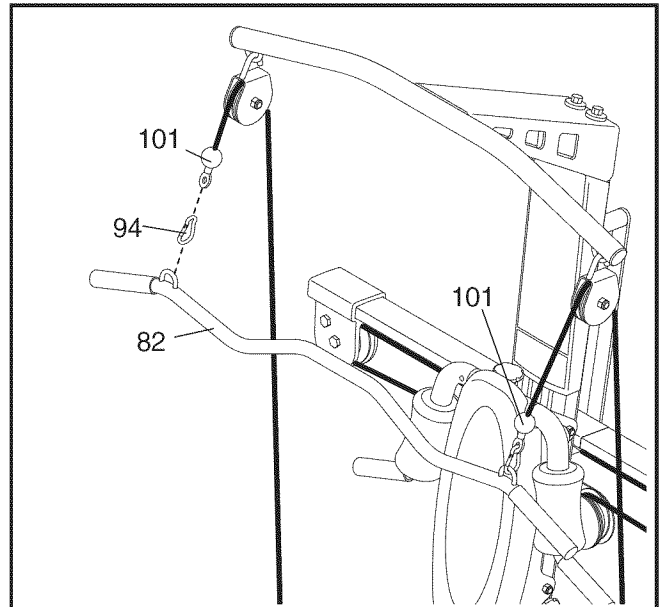

ADJUSTING THE SEAT

The Seat (45) can be secured at various positions on the Rail (4). To move the Seat, pull the Seat Knob (48) out as far as it will go and slide the Seat to the desired position. Engage the Seat Knob into an adjustment hole in the Rail.

To perform row exercises, the hip strap must be attached to the mech cable (see ATTACHING THE ACCESSORIES above), and the Seat Carriage (44) must be able to roll along the Rail (4). First, remove the Backrest (35) from the Seat Carriage (see ADJUSTING THE BACKREST on page 15). Then, pull the Seat Knob (48) out as far as it will go, and turn the Knob so that the pin rests at the end of the "L"-shaped slot (see the inset drawing).

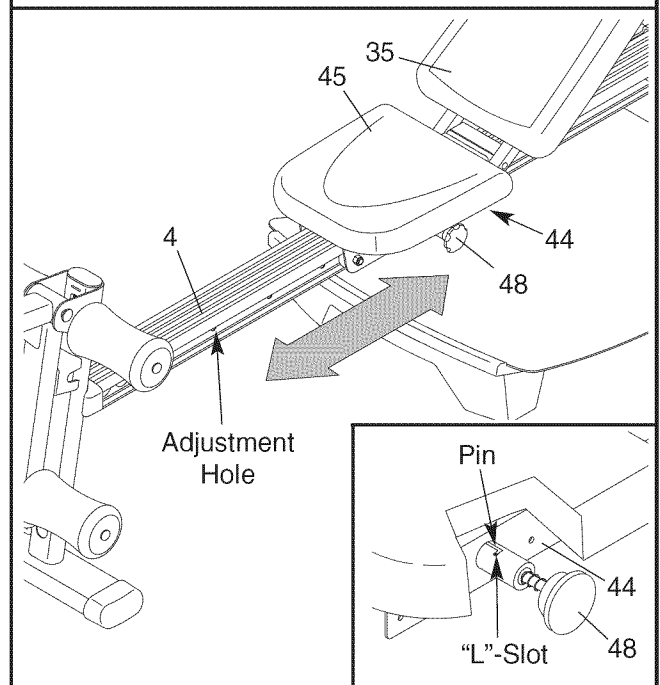

STORING THE RESISTANCE SYSTEM

To store the resistance system, first remove the Curl Pad (not shown) and the Leg Lever (not shown) from the resistance system. Secure the Seat Carriage (44) at the position closest to the Leg (5) (see ADJUSTING THE SEAT on page 16). Next, remove the Storage Knob (29) from the Row Plate (28). Lift the Leg toward the Top Frame (37), and tighten the Storage Knob into the side of the Row Plate and into the Rail (4).

To move the resistance system, stand behind the Upright (2) and place the toe of your shoe on the end of the Base Plate (1) and hold the resistance system in the indicated area. Tilt the resistance system back onto the Wheels (65) and roll it to the new location.

▲ WARNING: Make sure that Storage Knob (29) is in place and fully tightened each time the resistance system is used.

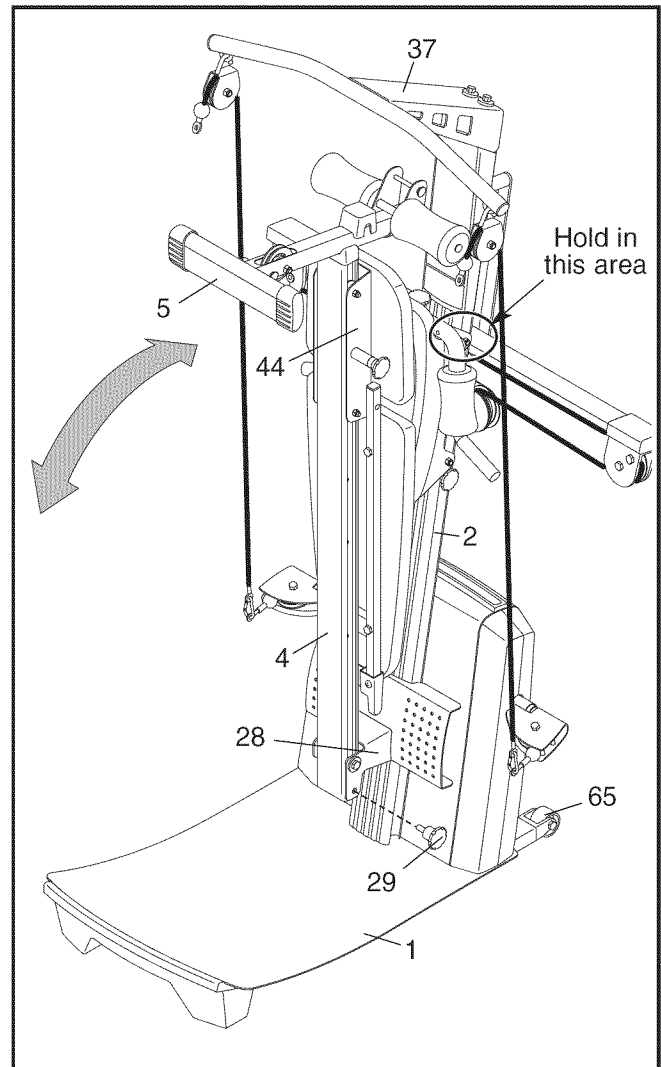

CONSOLE OPERATION

FEATURES OF THE CONSOLE

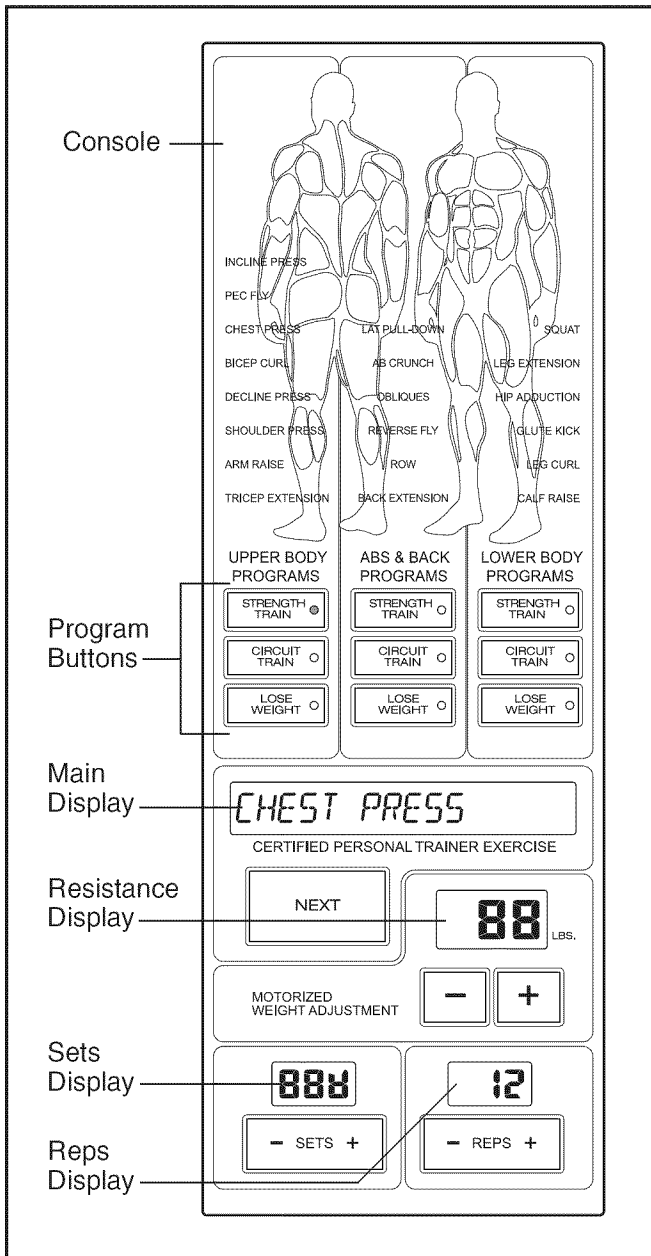

The heart of the resistance system is the digital resistance training console. The console offers both a manual mode and nine workout programs. When the manual mode is selected, the resistance setting can be changed with the touch of a button. When a program is selected, the console will guide you through an effective upper body, ab and back, or lower body workout.

To use the manual mode of the console, follow the steps at the right. To use a program, see page 17.

PLUGGING IN THE RESISTANCE SYSTEM

Plug the indicated end of the Transformer (72) into the Back Mech Cover (8). Plug the other end of the Transformer into a 120-volt outlet. All indicators and displays on the console will flash once; the console will then be ready for use. The motor may be heard while the resistance system calibrates itself. **Important: Always plug in the transformer when using the resistance system.**

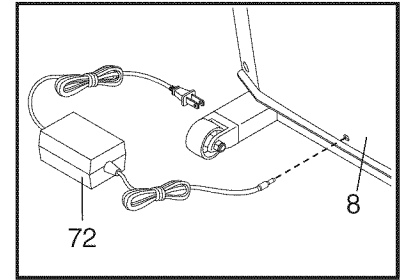

MANUAL OPERATION

1. Plug in the transformer.

Plug the transformer into a 120-volt outlet (see PLUGGING IN THE RESISTANCE SYSTEM above). **Important: Always plug in the transformer when using the resistance system.**

Note: When the power is on, the words MANUAL MODE will appear in the main display. To use a program, see PROGRAM OPERATION on page 17. If you want to return to the manual mode while the console is running a program, press and hold the NEXT button.

If no buttons are pressed and no cables are pulled for ten minutes, the console will go to sleep. Press any button to resume exercising.

2. Select a resistance setting.

The current resistance setting will appear in the resistance display. To select a different resistance setting, first **make sure that no cables are being pulled**. Next, press the resistance + and – buttons. Each time a button is pressed, the resistance setting will increase or decrease by 1 pound. To change the resistance setting quickly, hold down one of the buttons.

Note: While the resistance setting is changing, the motor will be heard. **To prevent damage to the motor, do not pull any of the cables while the resistance setting is changing.** If a cable is pulled, the words RELEASE HANDLES AND READJUST RESISTANCE AS DESIRED may appear in the main display.

Note: The resistance system uses progressive resistance. As the resistance bar begins to bend, the amount of resistance will increase gradually. As the bar bends further, the resistance will increase rapidly, up to 340 pounds.

3. Enter the numbers of sets and repetitions that you plan to complete for an exercise.

To enter the number of sets that you plan to do, press the SETS + and – buttons. To enter the number of repetitions that you plan to do, press the REPS + and – buttons.

Note: If you do not enter the numbers of sets and repetitions that you plan to do, the console will count the total number of repetitions that you complete during your workout.

4. Perform the exercise.

If you have entered numbers of sets and repetitions, the console will count down the repetitions and sets you have completed. When you complete the exercise, repeat steps 2 and 3 above for the next exercises.

5. Unplug the transformer.

When you complete your workout, unplug the transformer from the 120-volt outlet.

PROGRAM OPERATION

1. Plug in the transformer.

Plug the transformer into a 120-volt outlet (see PLUGGING IN THE RESISTANCE SYSTEM on page 16). **Important: Always plug in the transformer when using the resistance system.**

Note: If no buttons are pressed and no cables are pulled for ten minutes, the console will go to sleep. Press any button to resume exercising.

2. Select a program.

When the power is on, the words SELECT PROGRAM will appear in the main display. To select a program, press one of the nine program buttons. The indicator on the button you press will light.

Note: The console offers three upper body programs, three ab and back programs, and three lower body programs. If you wish to exercise your upper body and if your goal is to lose weight, for example, press the LOSE WEIGHT button below the words UPPER BODY PROGRAMS.

3. Row for five minutes to warm up.

When a program is selected, the words CARDIO ROW will appear in the main display. To warm up, perform the cardio row exercise while the main display counts down from 5 minutes.

Note: To see the correct form for the cardio row exercise, see the included exercise guide. If the resistance setting is too high or too low, select a different resistance setting by pressing the resistance + and – buttons.

4. Adjust the resistance setting and the numbers of sets and repetitions for the exercise if desired.

The name of an exercise in the program will appear in the main display. The recommended resistance setting and the recommended numbers of sets and repetitions for the exercise will appear in the three displays below the main display.

The recommended resistance setting and the recommended numbers of sets and repetitions may be too high or too low for you, depending on such factors as your body size and your physical condition. If desired, adjust the resistance setting and the numbers of sets and repetitions by pressing the + and – buttons below each display.

5. Perform the exercise.

As you perform the exercise, the console will count down the numbers of sets and repetitions you have completed.

When you complete the exercise, the word RESTING will appear in the main display. It is recommended that you rest while the main display counts down.

6. Perform the remaining exercises in the program.

After you have completed an exercise in the program, press the NEXT button and the name of the next exercise will appear in the main display. Repeat steps 4 and 5 above for the exercise.

Note: The program may include the same exercise twice, with different resistance settings and different numbers of sets and repetitions. If you wish to skip any part of the program, press the NEXT button to advance to the next part of the program.

When you complete the program, the words WORKOUT COMPLETE will appear in the main display.

7. Unplug the transformer.

When you complete your workout, unplug the transformer from the 120-volt outlet.

CABLE DIAGRAM

The cable diagram shows the proper routing of the upper cable (A). Use the diagram to make sure that the cable has been assembled correctly. If the cable has not been correctly routed, the resistance system will not function properly and damage may occur. The numbers show the correct route for the cable. **Make sure that the ends of the cable do not wrap around each other between positions 1 and 2, and 5 and 6.**

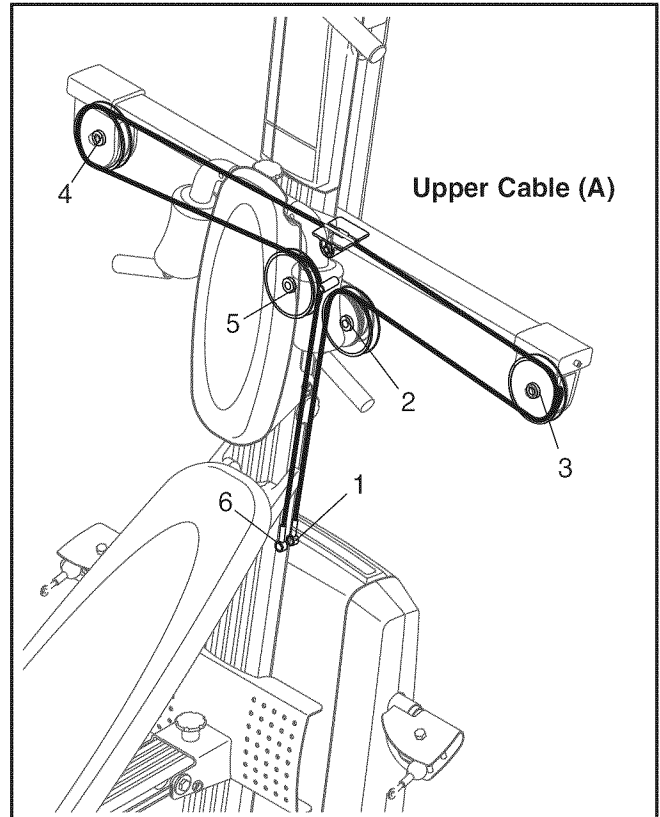

TROUBLESHOOTING

ADJUSTING THE CABLE TENSION

When the resistance setting changes, the motor will be heard. **To prevent damage to the motor, do not pull any of the cables while the resistance setting is changing.** If a cable is pulled, the words **RELEASE HANDLES AND READJUST RESISTANCE AS DESIRED** may appear in the main display on the console.

If this message is displayed repeatedly but no cable is being pulled, there may be too much tension on the upper cable (A). Adjust the tension as described below.

To decrease the tension on the upper cable (A), turn the two 3/8" x 38mm Tension Screws (13) twice, counterclockwise. Select the desired resistance setting. Repeat this step if necessary.

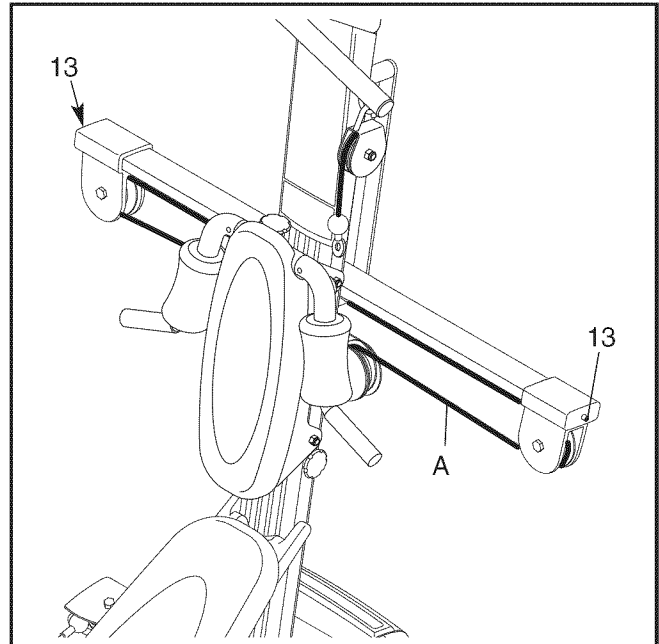

RECALIBRATING THE CONSOLE

To recalibrate the Console (67), first plug in the resistance system (see **PLUGGING IN THE RESISTANCE SYSTEM** on page 18). Then, press and hold the **NEXT** button and the **MOTORIZED WEIGHT ADJUSTMENT +** button for five seconds. When the buttons are released, a number will appear in the **REPS** display. Press the **NEXT** button again, then press the **MOTORIZED WEIGHT ADJUSTMENT +** button; this will start the recalibration process. This may take a few minutes as the motor moves between the lowest and highest resistance settings. When the motor finishes, unplug the transformer from the 120-volt outlet.

The Console (67) will be recalibrated. Use the resistance system as described in the **CONSOLE OPERATION** section, starting on page 18.

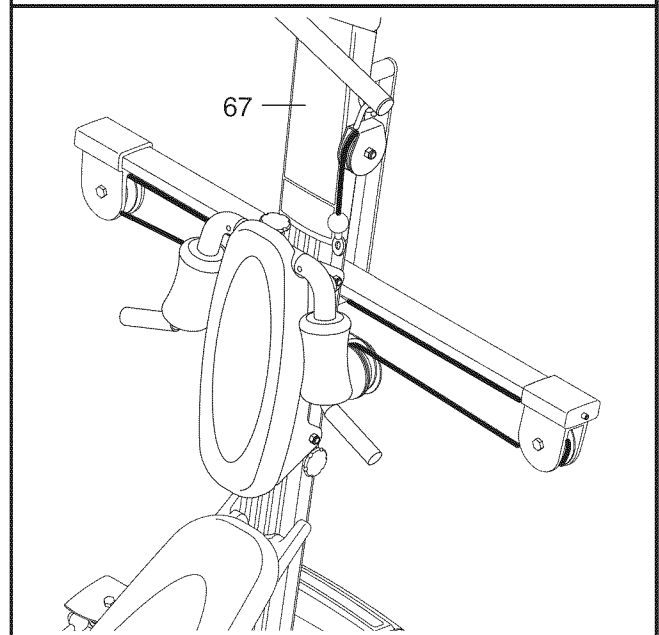

CLEANING THE BAR GUIDES

Over time, dust may build up on the Bar Guides (15), causing a squeaking noise as the resistance system is used. If this occurs, wipe off the Bar Guides with a damp cloth and a mild, non-abrasive detergent. Do not use solvents.

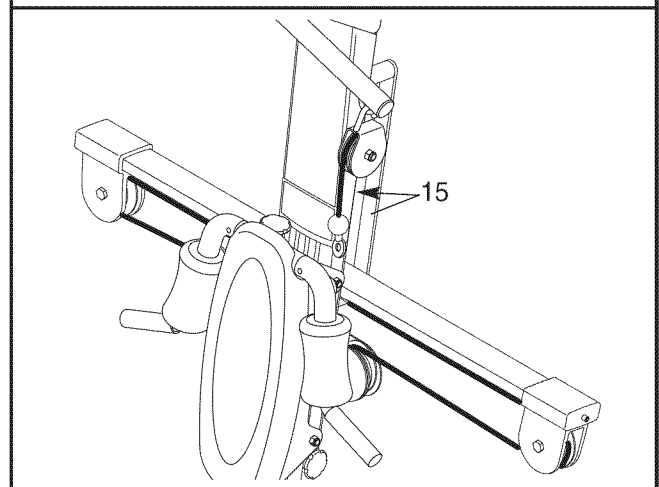

EXERCISE GUIDELINES

THE FOUR BASIC TYPES OF WORKOUTS

Muscle Building

To increase the size and strength of your muscles, push them close to their maximum capacity. Your muscles will continually adapt and grow as you progressively increase the intensity of your exercise. You can adjust the intensity level of an individual exercise in two ways:

- by changing the amount of resistance used
- by changing the number of repetitions or sets performed. (A “repetition” is one complete cycle of an exercise, such as one sit-up. A “set” is a series of repetitions.)

The proper amount of resistance for each exercise depends upon the individual user. You must gauge your limits and select the amount of resistance that is right for you. Begin with 3 sets of 8 repetitions for each exercise you perform. Rest for 3 minutes after each set. When you can complete 3 sets of 12 repetitions without difficulty, increase the amount of resistance.

Toning

You can tone your muscles by pushing them to a moderate percentage of their capacity. Select a moderate amount of resistance and increase the number of repetitions in each set. Complete as many sets of 15 to 20 repetitions as possible without discomfort. Rest for 1 minute after each set. Work your muscles by completing more sets rather than by using high amounts of resistance.

Weight Loss

To lose weight, use a low amount of resistance and increase the number of repetitions in each set. Exercise for 20 to 30 minutes, resting for a maximum of 30 seconds between sets.

Cross Training

Cross training is an efficient way to get a complete and well-balanced fitness program. An example of a balanced program is:

- Plan strength training workouts on Monday, Wednesday, and Friday.
- Plan 20 to 30 minutes of aerobic exercise, such as running on a treadmill or riding on an elliptical or exercise bike, on Tuesday and Thursday.
- Rest from both strength training and aerobic exercise for at least one full day each week to give your body time to regenerate.

The combination of strength training and aerobic exercise will reshape and strengthen your body, plus develop your heart and lungs.

PERSONALIZING YOUR EXERCISE PROGRAM

Determining the exact length of time for each workout, as well as the number of repetitions or sets completed, is an individual matter. It is important to avoid overdoing it during the first few months of your exercise program. You should progress at your own pace and be sensitive to your body’s signals. If you experience pain or dizziness at any time while exercising, stop immediately and begin cooling down. Find out what is wrong before continuing. Remember that adequate rest and a proper diet are important factors in any exercise program.

WARMING UP

Begin each workout with 5 to 10 minutes of stretching and light exercise to warm up. Warming up prepares your body for more strenuous exercise by increasing circulation, raising your body temperature and delivering more oxygen to your muscles.

WORKING OUT

Each workout should include 6 to 10 different exercises. Select exercises for every major muscle group, emphasizing areas that you want to develop most. To give balance and variety to your workouts, vary the exercises from session to session.

Schedule your workouts for the time of day when your energy level is the highest. Each workout should be followed by at least one day of rest. Once you find the schedule that is right for you, stick with it.

EXERCISE FORM

Maintaining proper form is an essential part of an effective exercise program. This requires moving through the full range of motion for each exercise, and moving only the appropriate parts of the body. Exercising in an uncontrolled manner will leave you feeling exhausted. On the exercise guide accompanying this manual you will find photographs showing the correct form for several exercises, and a list of the muscles affected. Refer to the muscle chart on page 23 to find the names of the muscles.

The repetitions in each set should be performed smoothly and without pausing. The exertion stage of each repetition should last about half as long as the return stage. Proper breathing is important. Exhale during the exertion stage of each repetition and inhale during the return stroke. Never hold your breath.

Rest for a short period of time after each set. The ideal resting periods are:

- Rest for three minutes after each set for a muscle building workout.
- Rest for one minute after each set for a toning workout.
- Rest for 30 seconds after each set for a weight loss workout.

Plan to spend the first couple of weeks familiarizing yourself with the equipment and learning the proper form for each exercise.

COOLING DOWN

End each workout with 5 to 10 minutes of stretching. Include stretches for both your arms and legs. Move

slowly as you stretch and do not bounce. Ease into each stretch gradually and go only as far as you can without strain. Stretching at the end of each workout is an effective way to increase flexibility.

STAYING MOTIVATED

For motivation, keep a record of each workout. List the date, the exercises performed, the resistance used, and the numbers of sets and repetitions completed. Record your weight and key body measurements at the end of every month. Remember, the key to achieving the greatest results is to make exercise a regular and enjoyable part of your everyday life.

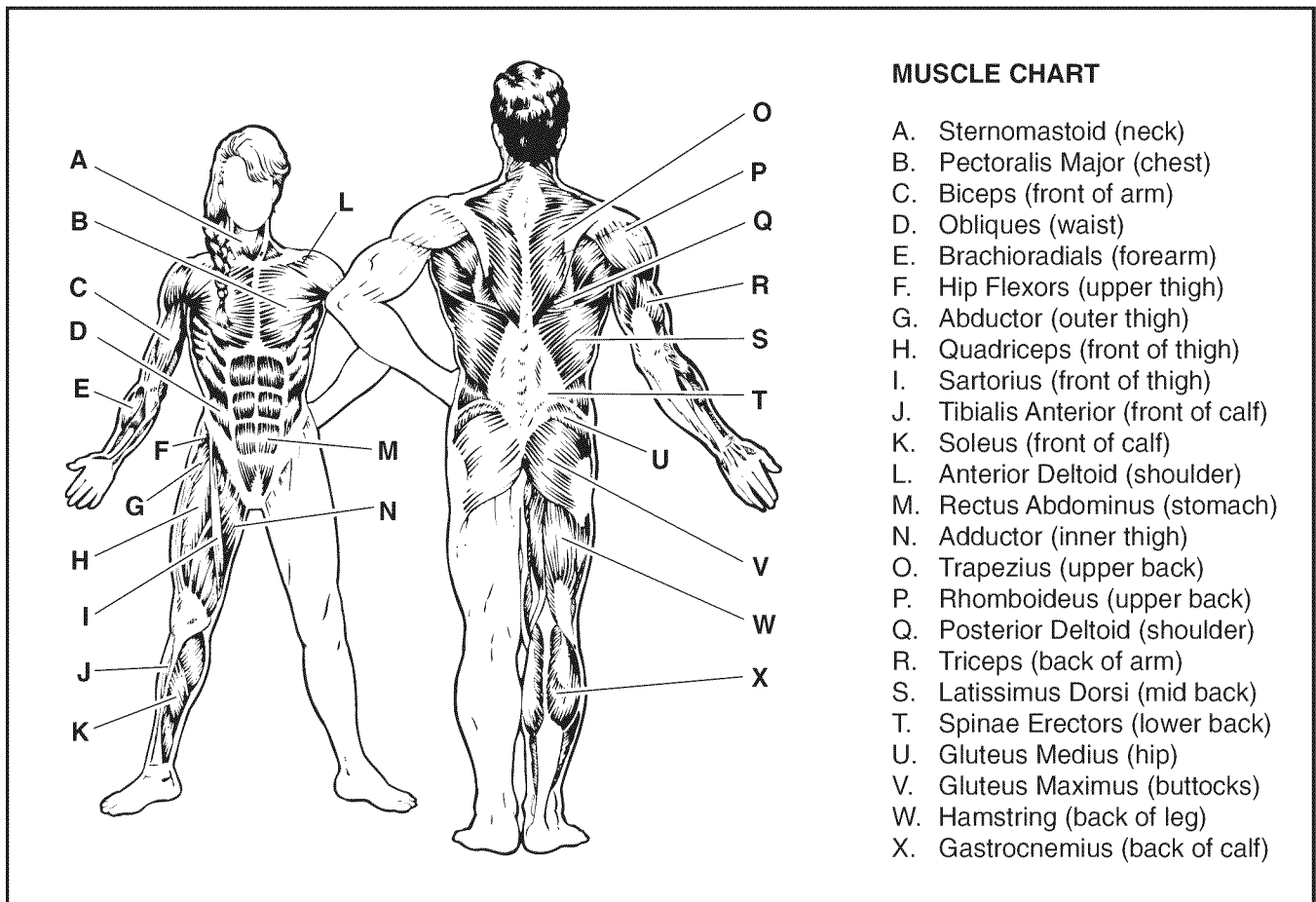

PART IDENTIFICATION CHART—Model No. 831.153971

R0304A

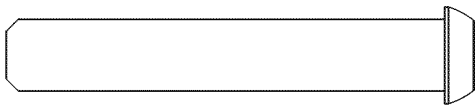

M10 x 58mm Button Screw (42)

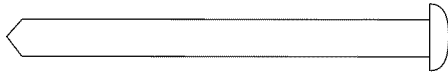

M5 x 56mm Screw (108)

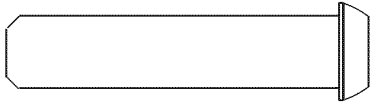

M10 x 44mm Button Bolt (93)

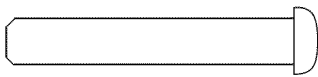

M6 x 38mm Screw (105)

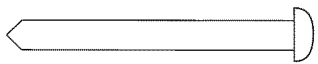

M4 x 38mm Screw (100)

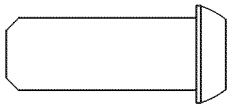

M10 x 25mm Button Screw (88)

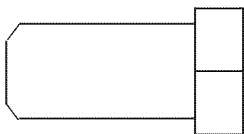

1/2" x 25mm Screw (85)

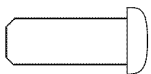

M6 x 16mm Screw (41)



M4 x 16mm Screw (53)

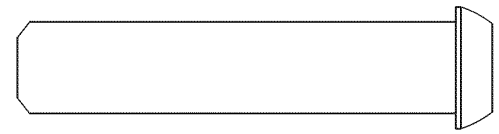

M12 x 58mm Button Bolt (87)

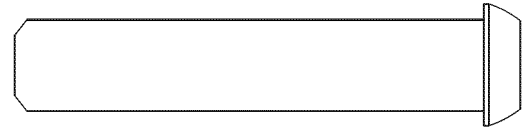

M12 x 62mm Button Bolt (81)

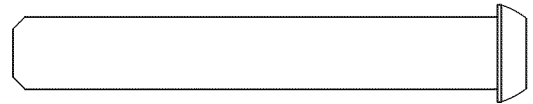

M10 x 64mm Button Bolt (80)

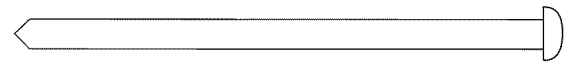

M4 x 70mm Screw (114)

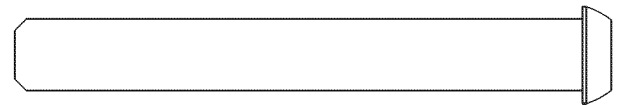

M10 x 75mm Button Bolt (84)

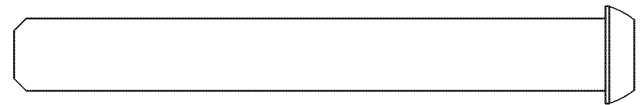

M10 x 78mm Button Bolt (99)

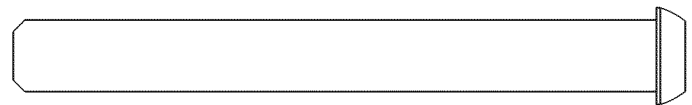

M10 x 85mm Button Bolt (92)

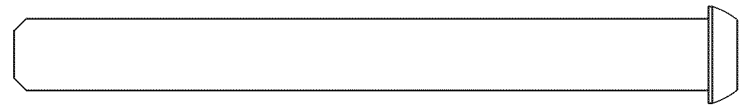

M10 x 92mm Button Bolt (83)

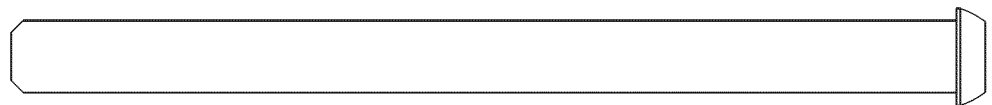

M10 x 125mm Button Bolt (89)

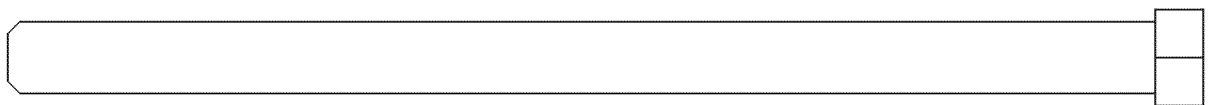

M10 x 152mm Bolt (86)

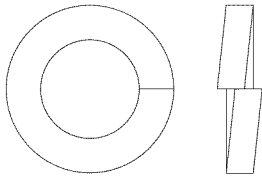

1/2" Lock Washer (12)

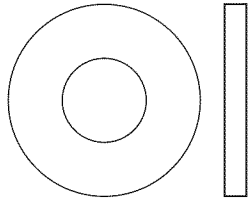

M10 Thick Washer (54)

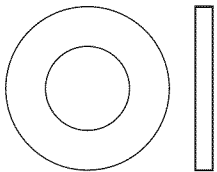

M10 Washer (106)

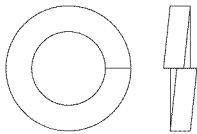

M10 Lock Washer (75)



M6 Washer (107)

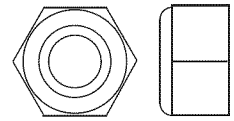

M10 Nylon Locknut (103)

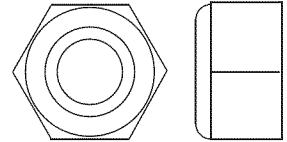

M12 Nylon Locknut (43)



22mm Spacer (61)



31mm Spacer (30)

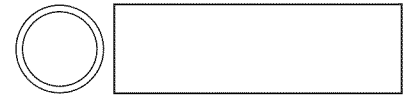

38mm Spacer (90)

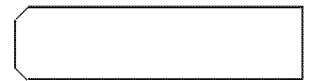

3/8" x 38mm Tension Screw (13)

PART LIST—Model No. 831.153971

R0304A

Key No.	Qty.	Description	Key No.	Qty.	Description	Key No.	Qty.	Description
1	1	Base Plate	44	1	Seat Carriage	85	1	1/2" x 25mm Screw
2	1	Upright	45	1	Seat			
3	1	Upright Cover	46	1	Pop Pin	86	2	M10 x 152mm Bolt
4	1	Rail	47	1	Knob Spring	87	2	M12 x 58mm Button Bolt
5	1	Leg	48	1	Seat Knob			
6	1	Mech Frame	49	1	Rail Cap	88	3	M10 x 25mm Button Screw
7	1	Front Mech Cover	50	2	Pad Tube			
8	1	Back Mech Cover	51	4	19mm Round Inner Cap	89	1	M10 x 125mm Button Bolt
9	1	Resistance Bar						
10	2	Pulley Bracket	52	4	Large Foam Pad	90	1	38mm Spacer
11	2	Bracket Plate	53	9	M4 x 16mm Screw	91	1	Reed Sensor
12	1	1/2" Lock Washer	54	3	M10 Thick Washer	92	1	M10 x 85mm Button Bolt
13	2	3/8" x 38mm Tension Screw	55	1	Leg Lever Bumper			
			56	1	Leg Lever	93	4	M10 x 44mm Button Bolt
14	4	Large Pulley	57	2	Leg Lever Bushing			
15	2	Bar Guide	58	1	Leg Station Cap	94	4	Cable Clip
16	1	Block Spacer	59	1	Curl Knob	95	2	Long Handle
17	1	Large Guide Spacer	60	2	Leg Station Pin	96	2	Short Handle
			61	2	22mm Spacer	97	1	Hip Strap
18	2	Small Guide Spacer	62	2	Leg Outer Cap	98	1	Ankle Strap
			63	1	Base Plate Foot	99	2	M10 x 78mm Button Bolt
19	1	Squat Carriage	64	2	Wheel Insert			
20	2	Squat Arm	65	2	Wheel	100	2	M4 x 38mm Screw
21	4	Short Handgrip	66	1	Squat Pin	101	2	High Cable
22	1	Squat Pivot Tube	67	1	Console	102	1	Leg Lever Cable
23	2	Squat Arm Roll Pin	68	1	Pulley Plate	103	31	M10 Nylon Locknut
24	2	Small Foam Pad	69	1	Cable Guide			
25	1	Squat Backrest	70	2	Tether	104	4	M10 x 34mm Button Bolt
26	8	Carriage Wheel	71	1	Upper Wire Harness	105	4	M6 x 38mm Screw
27	1	Squat Knob				106	14	M10 Washer
28	1	Row Plate	72	1	Transformer	107	4	M6 Washer
29	1	Storage Knob	73	2	Pulley Pivot Bracket	108	2	M5 x 56mm Screw
30	2	31mm Spacer				109	2	M4 x 7mm Machine Screw
31	1	Rail Insert	74	2	Pivot Bracket Bushing			
32	1	Backrest Frame				110	1	45mm Square Inner Cap
33	1	Backrest Cap	75	3	M10 Lock Washer			
34	2	25mm Square Inner Cap	76	1	M5 x 35mm Screw	111	4	M4 x 20mm Screw
			77	2	Carriage Strap	112	2	M4 x 5mm Screw (Round Head)
35	1	Backrest	78	4	M10 x 40mm Button Bolt	113	2	Cotter Pin
36	3	Plastic Foot				114	4	M4 x 70mm Screw
37	1	Top Frame	79	4	16mm Spacer	115	4	11mm Spacer
38	2	38mm Round Inner Cap	80	6	M10 x 64mm Button Bolt	#	1	User's Manual
39	2	Pulley Housing	81	2	M12 x 62mm Button Bolt	#	1	Exercise Guide
40	5	90mm Pulley				#	1	Large Allen Wrench
41	8	M6 x 16mm Screw	82	1	Lat Bar			
42	1	M10 x 58mm Button Screw	83	1	M10 x 92mm Button Bolt	#	1	Small Allen Wrench
43	4	M12 Nylon Locknut	84	5	M10 x 75mm Button Bolt			

Note: “#” indicates a non-illustrated part. Specifications are subject to change without notice. See the back cover of the user’s manual for information about ordering replacement parts. If a part is missing, call toll-free 1-877-992-5999.

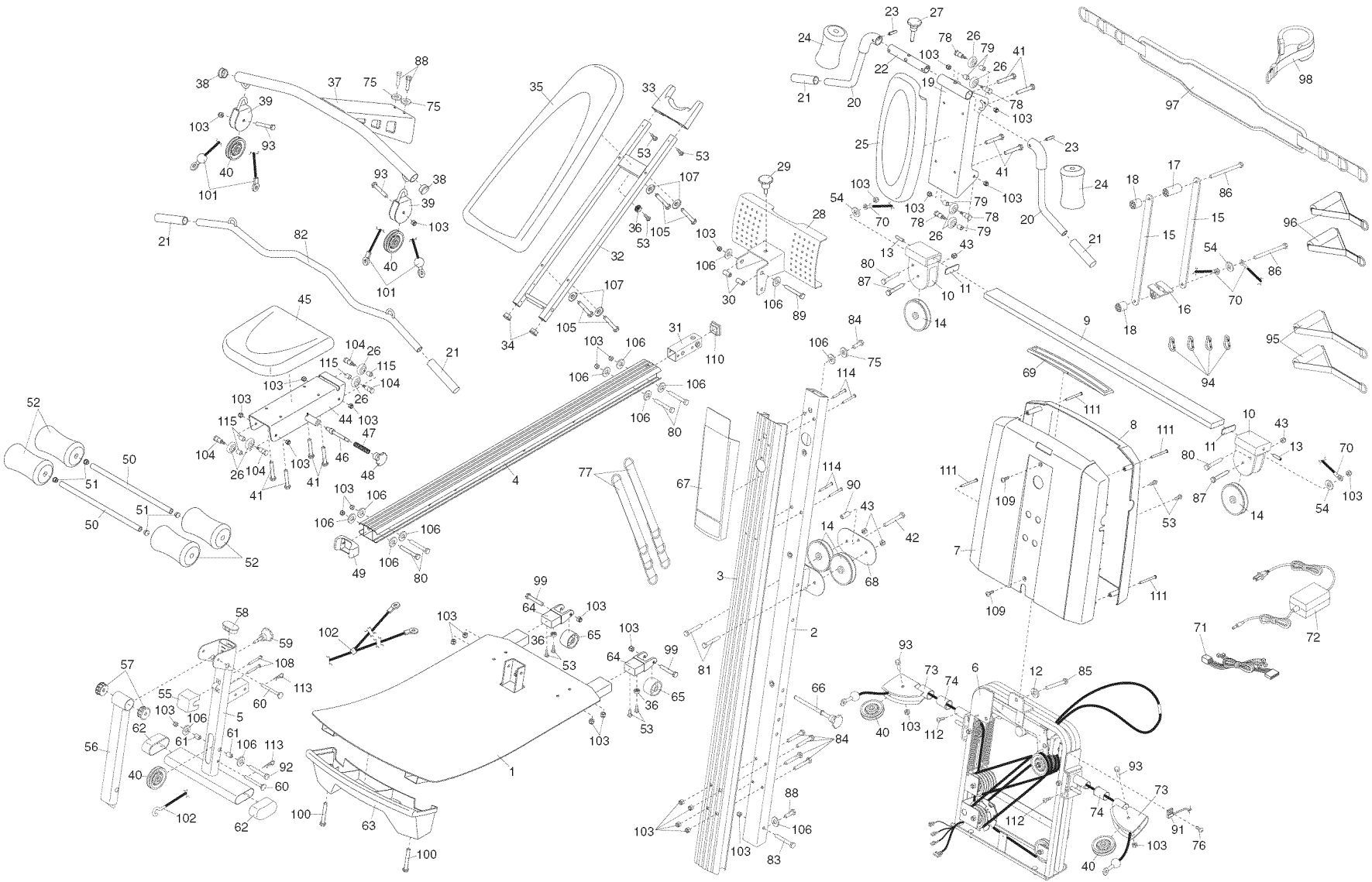

EXPLODED DRAWING—Model No. 831.153971

R0304A

Get it fixed, at your home or ours!

Your Home

For repair – **in your home** – of **all** major brand appliances, lawn and garden equipment, or heating and cooling systems, **no matter who made it, no matter who sold it!**

For the replacement parts, accessories, and user's manuals that you need to do-it-yourself.

For Sears professional installation of home appliances and items like garage door openers and water heaters.

1-800-4-MY-HOME®

(1-800-469-4663)

www.sears.com

Anytime, day or night

(U.S.A. and Canada)

www.sears.ca

Our Home

For repair of carry-in products like vacuums, lawn equipment, and electronics, call or go on-line for the location of your nearest **Sears Parts and Repair Center.**

1-800-488-1222 Anytime, day or night (U.S.A. only)

www.sears.com

To purchase a protection agreement (U.S.A.) or maintenance agreement (Canada) on a product serviced by Sears:

1-800-827-6655 (U.S.A.)

1-800-361-6665 (Canada)

Para pedir servicio de reparación a domicilio, y para ordenar piezas:

1-888-SU-HOGARSM (1-888-784-6427)

SEARS

® Registered Trademark / ™ Trademark / ™ Service Mark of Sears, Roebuck and Co.
© Marca Registrada / ™ Marca de Fábrica / ™ Marca de Servicio de Sears, Roebuck and Co.

FULL TEN-YEAR WARRANTY

For ten years from the date of purchase, if failure occurs due to defect in material or workmanship in this RESISTANCE SYSTEM EXERCISER, contact the nearest Sears Service Center throughout the United States and Sears will repair or replace the RESISTANCE SYSTEM EXERCISER, free of charge. The resistance bar will be replaced for the lifetime of the product.

This warranty does not apply when the RESISTANCE SYSTEM EXERCISER is used commercially or for rental purposes; or if damage is caused by freight damage, abuse, misuse, improper or abnormal usage or unauthorized repairs.

This warranty gives you specific legal rights, and you may also have other rights which vary from state to state.

Sears, Roebuck and Co., Dept 817WA, Hoffman Estates, IL 60179