

USE AND CARE MANUAL OUTDOOR REFRIGERATOR

For Use With Models:

OF24LS, OF24RS

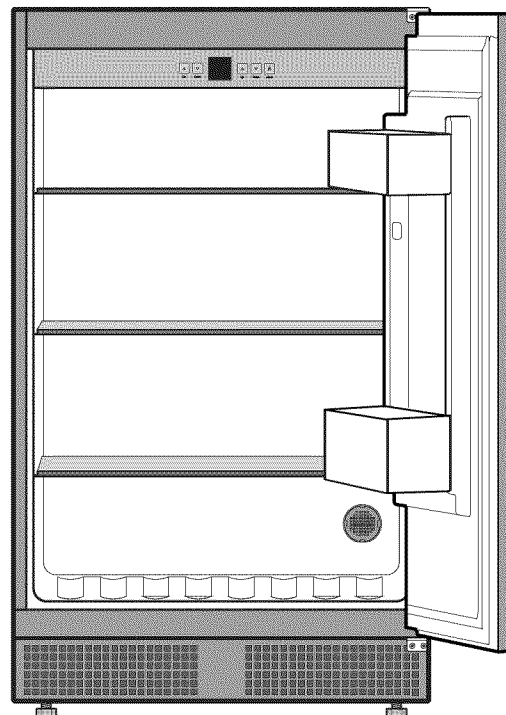

Table of Contents

Important Safety Instructions	1-2
Getting To Know Your Appliance.....	3
Operating Your Appliance	4-5
Cleaning and Maintenance	6-7
Before You Call for Service.....	7
Warranty and Service	8
Warranty Card	Back Cover



To Our Valued Customer:

Congratulations on your purchase of the very latest in Dacor® products! Our unique combination of features, style and performance make us The Life of the Kitchen™, and a great addition to your home.

In order to familiarize yourself with the controls, functions, and full potential of your new Distinctive Appliance, we suggest that you thoroughly read this use and care manual, beginning with the **Important Safety Instructions** section.

All Dacor appliances are designed and manufactured with quality and pride, while working within the framework of our company value. Should you ever experience a problem with your product, please first check the **Before You Call for Service** section of this manual for guidance. It provides useful suggestions and remedies prior to calling for service.

Valuable customer input helps us to continuously improve our products and services, so please feel free to contact our Customer Service Team for assistance with any of your product support needs.

Dacor Customer Service Team
1440 Bridge Gate Drive
Diamond Bar, CA 91765

Telephone: (800) 793-0093
Fax: (626) 403-3130
Hours of Operation: Monday through Friday
6:00 A.M. to 5:00 P.M. Pacific Time
Web Site: www.Dacor.com

Thank you for choosing Dacor for your home. We are a company built by families for families and we are dedicated to serving yours. We are confident that your new Dacor product will deliver a high level of performance and enjoyment for many years to come.

Sincerely,

Cheryl Crowe
Director, Customer Satisfaction

Important Safety Instructions

Installer: Leave these instructions with the appliance.

Customer: Read this use and care manual completely before using your refrigerator. Save it for future reference. It contains important use and care information. Keep your sales receipt or canceled check in a safe place. Proof of original purchase date is required for warranty service.

If you have any questions, call:

Dacor Customer Service Team
1 (800) 793-0093 (U.S.A. and Canada)
Monday — Friday 6:00 A.M. to 5:00 P.M. Pacific Time
Web site: www.Dacor.com

Have the complete model and serial number for your appliance ready. These numbers are found on the serial number plate located inside the door on the left side. Record these numbers below for future reference.

Model Number _____

Serial Number _____

Date of Purchase _____

For warranty and service information, see page 8.

Since Dacor continuously improves the quality and performance of our products, we may need to make changes to the appliance without updating this manual.

IMPORTANT INFORMATION ABOUT SAFETY INSTRUCTIONS

The **Important Safety Instructions** and warnings in this manual can not cover all possible problems and conditions that may occur. Use common sense and caution when installing, maintaining or operating this appliance.

Always contact Dacor about problems or conditions you don't understand.

Safety Symbols and Labels

DANGER

Immediate hazards that **WILL** result in severe personal injury or death.

WARNING

Hazards or unsafe practices that **COULD** result in severe personal injury or death.

CAUTION

Hazards or unsafe practices that **COULD** result in minor personal injury or property damage.

DANGER

IMPORTANT: To prevent child entrapment and suffocation when discarding an old appliance:

- Remove the door(s).
- Leave the shelves in place so children can not easily climb inside.
- Cut the prongs off the power plug and discard them.
- Cut the power cable off and discard it separately from the old appliance.

IMPORTANT: To avoid fire or explosion, do not operate this appliance in the presence of explosive materials or fumes, such as gasoline.

IMPORTANT: This appliance is equipped with a three-prong grounding electric plug for protection against possible electric shock hazards. It must be plugged into a dedicated, grounded, electrical outlet. If only a two-prong electrical outlet is available, it is the responsibility of the customer to have it replaced with a dedicated, properly grounded three-prong electrical outlet. Do not under any circumstances:

- Cut or remove the third (ground) prong from the power cord.
- Use an adapter plug.
- Use a power cord that is frayed or damaged.
- Connect the appliance to an extension cord.

NOTE: Use of a ground fault interrupter (GFI) is not recommended.

Power supply cord with three-prong grounding plug

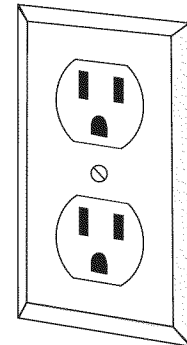
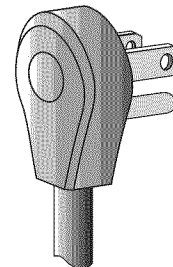

Grounded type electrical outlet (GFI not recommended)

READ AND SAVE THESE INSTRUCTIONS

Important Safety Instructions

GENERAL SAFETY PRECAUTIONS

To reduce the risk of fire, electric shock, serious injury or death when using this appliance, follow basic safety precautions, including the following:

WARNING

1. If you receive a damaged product, immediately contact your dealer or builder. Do not install or use a damaged appliance.
2. To prevent personal injury, property damage, or damage to the unit, this appliance should only be unpacked and set up by two people according to the accompanying installation instructions.
3. Keep packaging materials away from children. Plastic sheets and bags can cause suffocation.
4. This appliance must be installed properly by a qualified installer according to the accompanying installation instructions.
5. Connect this appliance only to a 120 Vac, 15 Amp circuit that is controlled by a circuit breaker or fuse. This appliance should have its own dedicated, grounded circuit.
6. Do not install, repair or replace any part of the appliance unless specifically recommended in the literature accompanying it. A qualified service technician should perform all other service.
7. Before performing any type of service on this unit, disconnect the power plug from the electrical outlet.
8. Use this appliance only for its intended purpose; the storage of food and beverages. It is not intended for commercial use.
9. Never allow anyone, including children to sit, stand or climb on any part of the appliance, including the door. Doing so may cause, damage, serious injury or death.
10. Do not tamper with the controls.
11. Keep the power cord away from heated surfaces.
12. If "F0" or "F1" appears on the display, a fault has occurred. Unplug the appliance and contact Dacor customer service.

CAUTION

1. To protect the appliance from possible damage, allow it to stand in place 1/2 to 1 hour after moving before turning the electricity on. Doing so allows the refrigerant and system lubrication to reach equilibrium. If the unit has been tipped over completely, let it stand for 24 hours.
2. In the event of a power outage, minimize opening the door.
3. Do not allow the ventilation grill below the door to become obstructed. Make sure there is always good ventilation in front of the appliance.
4. When disconnecting the power cord, do not pull on the cable. Instead, grasp the plug and pull it out of the electrical outlet.
5. Do not use abrasive or caustic cleaners or detergents on this appliance. They may permanently damage the finishes. Do not use aerosol cleaners on this unit. They may be flammable or cause corrosion of metal parts.

Getting to Know Your Appliance

FEATURES

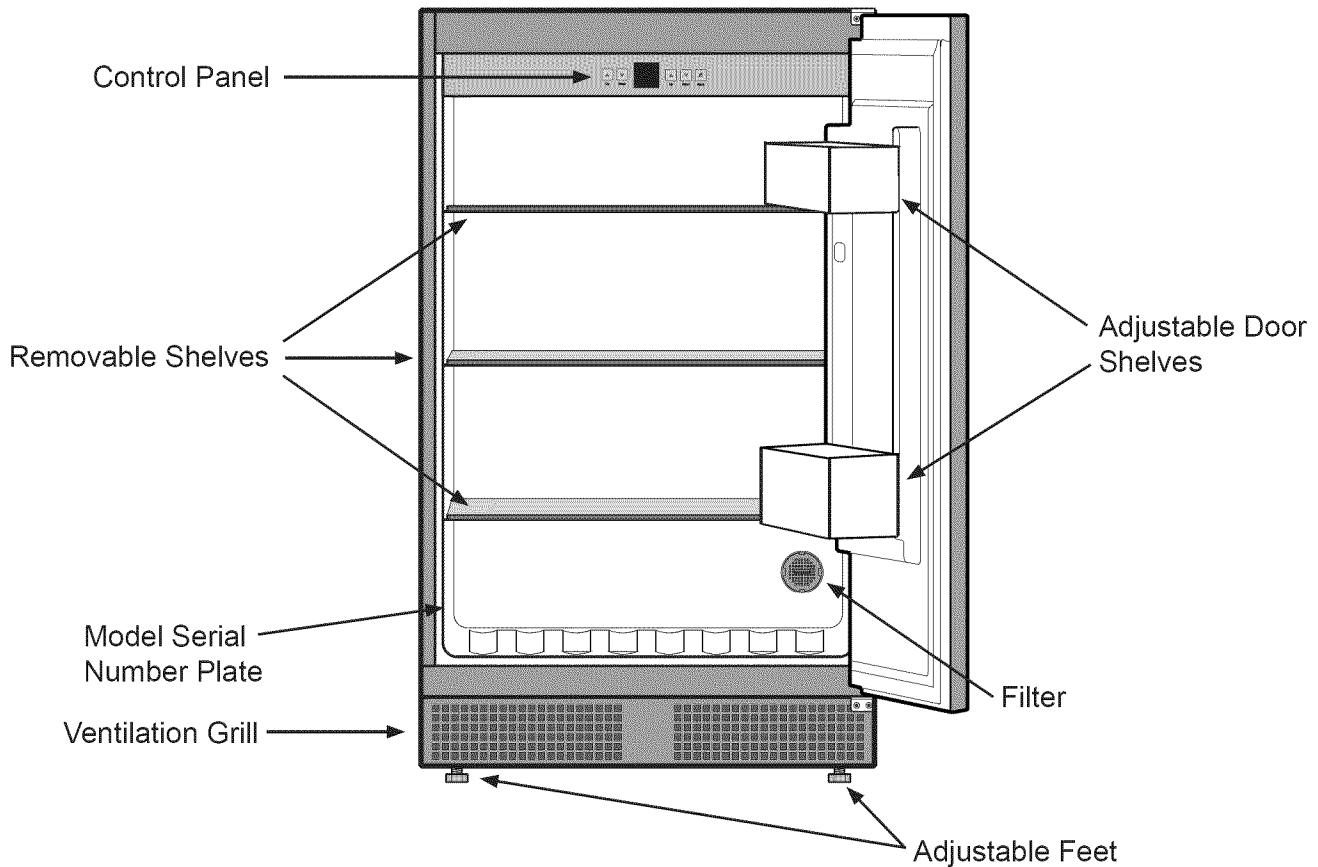

Model Numbers:

OF24LS (Left swinging door with handle on right)

OF24RS (Right swinging door with handle on left)

Additional Features

- ❖ Wide temperature setting range, 34 to 68°F (1 to 20°C)
- ❖ User-friendly electronic controls
- ❖ Electronic display
- ❖ Door open alarm
- ❖ Child-resistant lock on the control panel
- ❖ Easy to clean
- ❖ Heavy duty compressor for outdoor use
- ❖ Long lasting UV resistant door gasket
- ❖ Energy efficient design with low energy consumption
- ❖ CFC-free

Safety Features

- The refrigerant system on this appliance has been tested for leaks.
- This appliance also complies with UL250 and CSA C22.2 #63. It is designed to cool and store food and beverages.

Temperature Requirements

Your appliance can operate within the ambient temperature limits listed below. These temperature limits should not be exceeded for proper operation.

AMBIENT TEMPERATURE REQUIREMENTS FOR PROPER OPERATION

50°F to 109°F (11°C to 42°C)

Operating Your Appliance

THE CONTROL PANEL

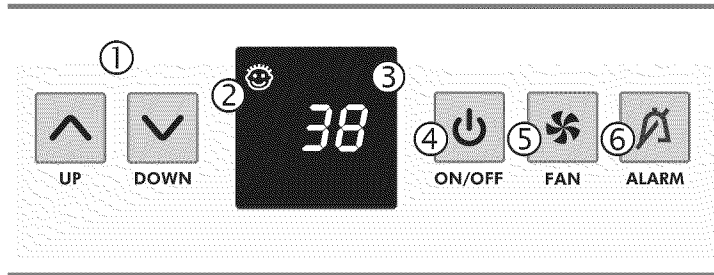

- ① Temperature setting buttons
- ② Child-resistant lock indicator
- ③ Temperature display
- ④ **ON/OFF** button
- ⑤ **FAN** on/off button
- ⑥ **ALARM** on/off button

Turning the Power ON and OFF

- Clean your appliance before turning it on for the first time. See the *Cleaning and Maintenance* section.
- Connect the power cord to the electrical outlet. The unit will come on.
- The alarm will sound and the temperature display will flash because the beverage compartment is warm when you first turn it on (see the Alarm section for details). Push the **ALARM** button to turn the alarm off while compartment is cooling down to operating temperature. The temperature display will continue to flash until the interior has cooled.
- To turn the unit off: Push and hold the **ON/OFF** button for about three seconds. The display will turn off to indicate that the appliance is off.
- To turn it on: Push the **ON/OFF** button until the display lights up.

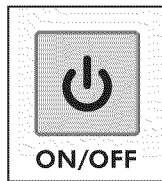

Setting the Temperature

- Push the **UP** or **DOWN** button to raise or lower the temperature. You can change the settings in increments of 1°F (or 1°C). The temperature setting will flash on the display while you change it.
- After 5 seconds the display will stop flashing and the actual temperature of the compartment will be displayed.

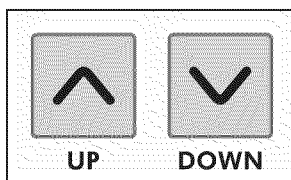

Control Panel Settings (Set-up Mode)

In set-up mode you can turn the child-resistant lock on and off, set the temperature scale to Fahrenheit or Celsius, and adjust the brightness of the display.

Changing the temperature scale (°F or °C)

You can select the temperature scale that the unit uses to display the temperature settings:

- Push and hold the **FAN** button for about five seconds to enter set-up mode. The display will begin to flash.
- Push the **UP** button until the degree symbol "°" flashes on the display.

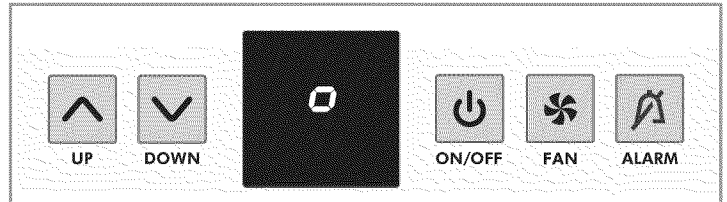

- Push the **FAN** button. °F or °C will flash on the display.

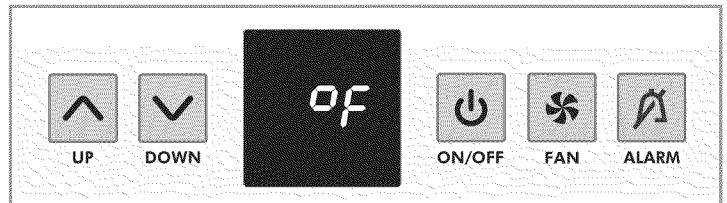

- Push the **UP** or **DOWN** button until the desired temperature scale flashes on the display. Push the **FAN** button to select the desired temperature scale.
- Push the **ON/OFF** button to exit set-up mode.

Within about two minutes, the appliance will change the temperature scale on the display.

To change the display brightness

- Push and hold the **FAN** button for about five seconds to enter set-up mode. The display will begin to flash.
- Push the **UP** button until an "h" flashes on the display. Push the **FAN** button. The current display brightness level, from 1 to 5 will flash on the display. **h1** is the lowest level. **h5** is the highest.

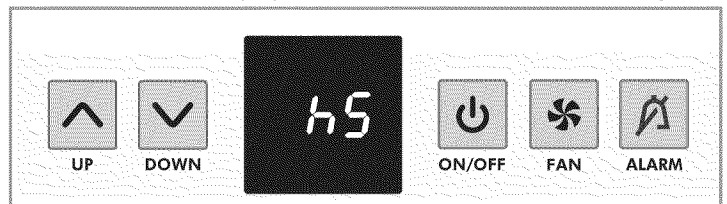

- Push the **UP** or **DOWN** button until the desired brightness level flashes on the display. Push the **FAN** button to select the desired brightness level.
- Push the **ON/OFF** button to exit set-up mode.

Operating Your Appliance

Child-Resistant Lock

The child-resistant lock feature makes it more difficult for a child to tamper with the controls. The child-resistant lock indicator appears on the display when the lock is on.



To lock (or unlock) the control panel:

- Push and hold the **LIGHT** button for about five seconds to enter set-up mode. The display will begin to flash.
- Push the **UP** button until “C” flashes on the display.

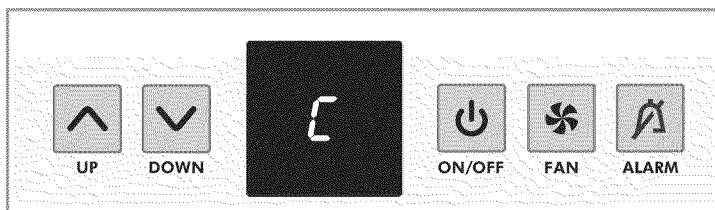

- Push the **FAN** button. **C0** or **C1** will flash on the display.
 - **C0** means that the lock is off.
 - **C1** means that the lock is on.

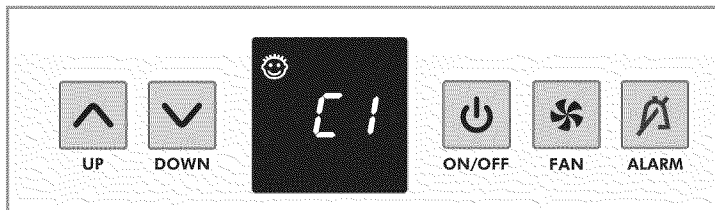

- Push the **UP** button to display the desired mode. Push the **FAN** button to select that mode.
- Push the **ON/OFF** button to exit set-up mode.

Turning on the Fan

The fan increases the humidity level inside the refrigerator.

- To turn it on, push the **FAN** button. Push it again to turn it off.
- The fan indicator is lit on when the fan is on.

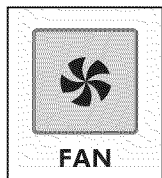

Alarm

The alarm helps to protect the food against excessive temperature fluctuations. The alarm sounds when the door is open for longer than three minutes. It also sounds when the interior gets too warm or too cold. The temperature display will also flash. It will continue to flash until the temperature problem has been fixed, even if the alarm has been muted.

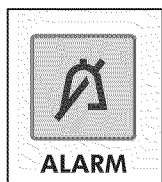

- To mute the alarm, push the **ALARM** button.

INTERIOR LIGHTING

The light is located behind the cover on the ceiling of the food storage compartment.

The light switches off automatically after the door has been opened for about 15 minutes. If it does not switch on when the door is opened briefly, but the temperature setting display is lit, the interior light may be burned out. See the **Cleaning and Maintenance** section.

ADJUSTING THE DOOR SHELVES

Adjustable Door Rack

- Slide the door rack up and pull it out toward you.
- Replace in reverse order.

Bottle Holder

- You can protect bottles from falling over when the door is opened and closed. Slide the divider sideways inside the shelf enclosure. Always hold it by the plastic handle.

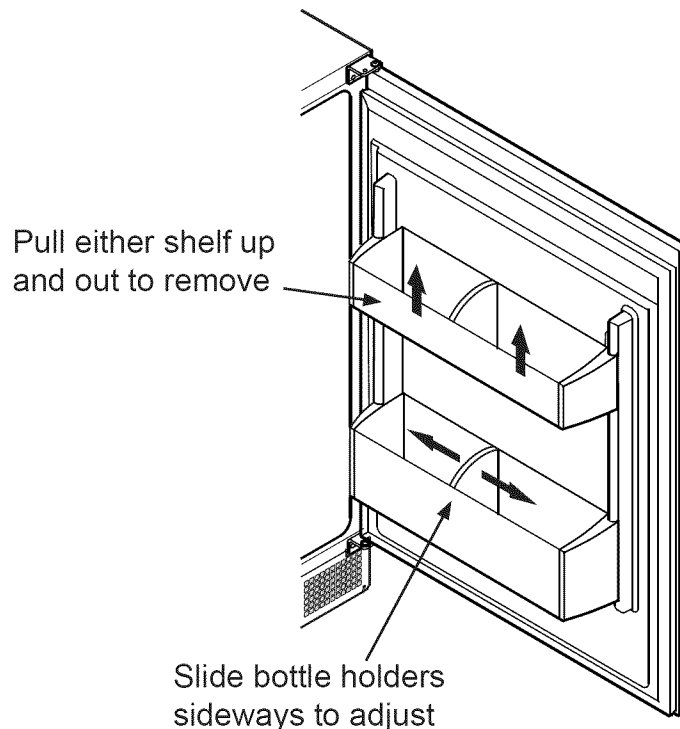

Cleaning and Maintenance

WARNING

To avoid possible injury due to electric shock, disconnect the power cord before cleaning the appliance.

- Clean only the parts of the unit listed in this manual. Clean them only in the manner specified.
- Do not use a steam cleaner to clean this appliance. Steam could penetrate the electrical components and cause a short circuit.
- Do not allow water or cleaning fluids to penetrate into the electrical components, control panel or ventilation grill.

To avoid damage to your appliance's surfaces and accessories during cleaning:

- Use only the types of cleaning solutions specified in this manual.
- Do not use abrasives such as steel wool, scouring pads, rough sponges, or scrub brushes.
- Always wipe stainless steel (silver colored) surfaces with the grain.

DEFROSTING

The refrigerator compartment defrosts automatically. Water may form on the rear wall as part of the defrost process. It drains into a reservoir at the back of the appliance and is heated so that it evaporates.

CLEANING THE SURFACES

Stainless Steel Surfaces

- Clean stainless steel surfaces with a mild solution of detergent and warm water. Rinse and dry with a soft, lint-free cloth.
- You may also use Dacor Stainless Steel Cleaner on the stainless steel surfaces. Use it according to the directions on the package.
- Stainless steel that is exposed to chlorine gas and moisture may have some discoloration. This discoloration is normal. If your unit is used in this type of environment, clean and polish your stainless steel more often.
- If the surface discolors or rust appears, clean it quickly with a non-abrasive cloth and protect it.

Interior Surfaces

- Clean interior surfaces with a mild solution of detergent and warm water. Rinse and dry with a soft, lint-free cloth.

Glass Surfaces

- The interior glass shelves may be removed for cleaning.
- To remove finger prints on glass surfaces, use a mild glass cleaner with a soft damp rag.

Other Surfaces

- Clean all other surfaces with a soft damp rag. You may soak the rag with a mild detergent solution.
- Be sure to keep the ventilation grill below the door clean of dirt and lint. You may wipe it with a soft damp rag or clean it using a vacuum cleaner.

REPLACING THE FILTER

Your refrigerator circulates fresh air through an activated charcoal filter located in the back bottom right-hand corner.

Dacor recommends that you replace the filter at least once a year. Filters (Dacor part number 101844) may be obtained from your Dacor Dealer or at www.everythingdacor.com.

To remove the old filter:

- Disconnect the power cord from the electrical outlet.
- Hold the filter by the handle in the center.
- Turn it 90° to the left or right. Pull it out.

To install the new filter:

- Insert it with the handle in the vertical position.
- Turn it 90° to the left or right until it clicks into place.
- Reconnect the power cord.

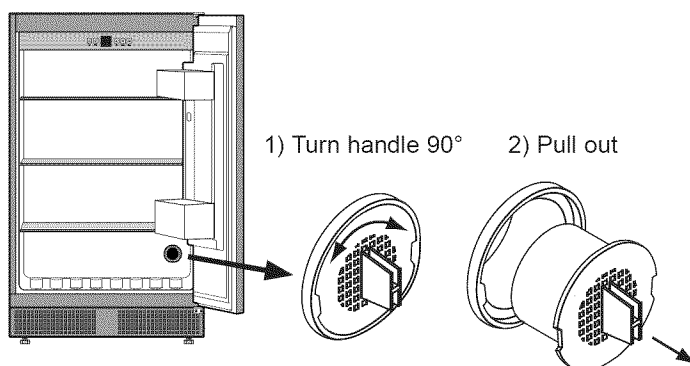

Filter Removal

ADJUSTING THE FEET

You can adjust and level the appliance height using the four adjustable feet on the underside of the appliance.

1. Place a level on one of the racks inside the appliance.
2. Check to make sure it is level front to back and side to side.
3. Re-adjust the feet if necessary. Make sure all four feet hit the floor and that the unit does not rock.

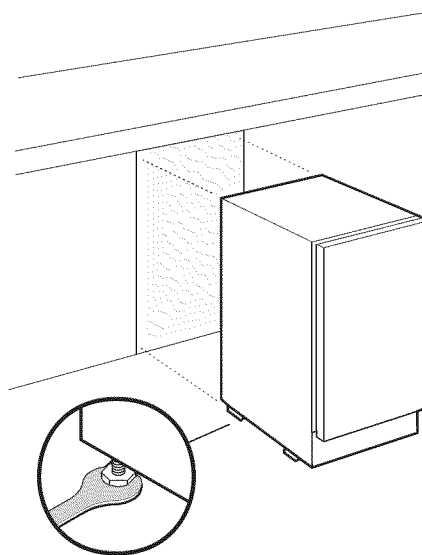

Cleaning and Maintenance

REPLACING THE LIGHT

WARNING

- To prevent the possibility of electric shock, be sure to disconnect the power cord before replacing the interior light tube.
- To prevent possible injury due to broken glass, wear hand protection when replacing the interior light tube.

Replace the light tube with Dacor part number 101777. The light fixture is mounted in the ceiling toward the front of the unit.

4. Unscrew the cover panel.
5. Turn the tube 90° and pull it out, downwards.
6. Insert the new tube and turn 90°.
7. Replace the cover panel and screw it into place.

If the light does not work after replacement, call your dealer or the Dacor Customer Service Team for service.

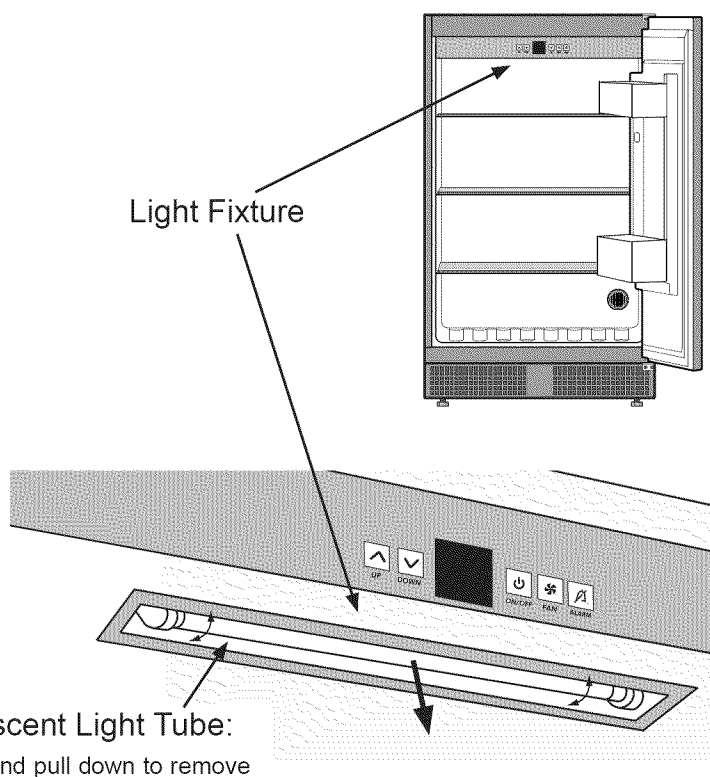

Before You Call for Service

PROBLEM SOLUTION GUIDE

PROBLEM	MAY BE CAUSED BY	WHAT TO DO
Nothing works. Appliance does not cool, control panel display is off, and lights do not work.	Appliance not connected to power.	Make sure appliance is plugged in.
	Electricity to power outlet is off.	Turn power on at circuit breaker or fuse box. Check for tripped circuit breaker or blown fuse.
	Appliance is turned off.	See Turning the Power On and Off on page 4.
	Power outage.	Contact power company.
Light does not come on.	No power.	See nothing works, above.
	Light bulb burned out.	See Replacing the Light Bulb , above.
Loud running noise.	Bottles vibrating.	Adjust bottles and racks to minimize vibration.
Appliance runs constantly.	Ambient temperature too hot.	Make sure room temperature is between limits on ambient temperature chart on page 3.
	Door has been left ajar.	Make sure door is firmly shut.
	Appliance too close to heat source.	Have a technician or installer modify the refrigerator installation or the heat source, or move the refrigerator away from the heat source.
Temperature not cold enough.	Temperature not set properly.	See Setting the Temperature on page 4.
	See "Appliance runs constantly", above.	
F0 or F1 appears on the display.	Appliance has a fault.	Disconnect the power cord. Call for service. See Getting Help on page 8 for details.

Warranty and Service

Product Maintenance

Do not perform any maintenance other than that instructed in the **CLEANING AND MAINTENANCE** section of this manual. A qualified service technician should perform all other service.

Getting Help

Before you obtain service, please review the **Before You Call for Service** section of this manual starting on page 7. If you have performed the checks in the **Problem Solution Guide** and the problem has not yet been remedied, please visit our web site or contact our Customer Service Team for a listing of Dacor authorized service agents. Prior to requesting service, it is helpful to be familiar with the warranty terms and conditions on this page.

Contact us through our web site at:

www.Dacor.com

Dacor Customer Service:

Tel: (800) 793-0093

Fax: (626) 403-3130

Business Hours: 6:00 A.M. - 5:00 P.M. Pacific Time

You may also write us at:

Dacor Customer Service
1440 Bridge Gate Drive
Diamond Bar, CA 91765

At Dacor, we believe that our quality of service equals that of our product. Should your experience with our service network or product be different, please contact our Customer Service Team and share your encounter with us. We will do our utmost to resolve the situation for you and deliver on our Dacor promise.

If you need anything clarified, just let us know.

What Is Covered

CERTIFICATE OF WARRANTIES DACOR OUTDOOR REFRIGERATORS

WITHIN THE FIFTY STATES OF THE U.S.A., THE DISTRICT OF COLUMBIA, AND CANADA*:

FULL TWO-YEAR WARRANTY

If your DACOR product fails to function within two years of the original date of purchase, due to a defect in material or workmanship, DACOR will remedy the defect without charge to you or subsequent users. The owner must provide proof of purchase upon request, and have the appliance accessible for service.

* Warranty is null and void if non-CSA approved product is transported from the U.S.

FULL FIVE-YEAR WARRANTY

For five years from the date of original purchase, your DACOR warranty covers all parts and labor to repair or replace any components that prove to be defective in materials or workmanship in the sealed system. The "sealed system" means only the compressor, condenser, evaporator, drier, and all connecting tubing.

LIMITED 6TH THROUGH 12TH YEAR WARRANTY

From the 6th through 12th year from the date of original purchase, your DACOR warranty covers all parts that prove to be defective in materials or workmanship in the sealed system (parts only).

OUTSIDE THE FIFTY STATES OF THE U.S.A., THE DISTRICT OF COLUMBIA, AND CANADA:

LIMITED TWO YEAR WARRANTY

If your DACOR product fails to function within two years of the original date of purchase, due to a defect in material or workmanship, DACOR will furnish a new part, F.O.B. factory, to replace the defective part. All delivery, installation, and labor costs are the responsibility of the purchaser. The owner must provide proof of purchase, upon request, and have the appliance accessible for service.

LIMITED TWELVE YEAR WARRANTY

If your DACOR product fails to function within twelve years of the original date of purchase, due to a defect in material or workmanship of any components in the sealed system, DACOR will furnish a new part, F.O.B. factory, to replace the defective part. All delivery, installation, and labor costs are the responsibility of the purchaser. The owner must provide proof of purchase, upon request, and have the appliance accessible for service. The "sealed system" means only the compressor, condenser, evaporator, drier, and all connecting tubing.

What Is Not Covered

- Service calls to educate the customer in the proper use and care of the product.
- Failure of the product when used for commercial, business, rental, or any application other than for residential consumer use.
- Replacement of house fuses or fuse boxes, or resetting of circuit breakers.
- Damage to the product caused by accident, fire, flood, or other acts of God.
- Breakage, discoloration or damage to glass, metal surfaces, plastic components, trim, paint or other cosmetic finish, caused by improper usage or care, abuse or neglect.

THE REMEDIES PROVIDED FOR IN THE ABOVE EXPRESS WARRANTIES ARE THE SOLE AND EXCLUSIVE REMEDIES. THEREFORE, NO OTHER EXPRESS WARRANTIES ARE MADE, AND OUTSIDE THE FIFTY STATES OF THE UNITED STATES, THE DISTRICT OF COLUMBIA, AND CANADA, ALL IMPLIED WARRANTIES, INCLUDING BUT NOT LIMITED TO, ANY IMPLIED WARRANTY OF MERCHANTABILITY OR FITNESS FOR A PARTICULAR USE OR PURPOSE, ARE LIMITED IN DURATION TO ONE YEAR FROM THE DATE OF ORIGINAL PURCHASE. IN NO EVENT SHALL DACOR BE LIABLE FOR INCIDENTAL EXPENSE OR CONSEQUENTIAL DAMAGES. NO WARRANTIES, EXPRESS OR IMPLIED, ARE MADE TO ANY BUYER FOR RESALE.

Some states do not allow limitations on how long an implied warranty lasts, or do not allow the exclusion or limitation of inconsequential damages, so the above limitations or exclusions may not apply to you. This warranty gives you specific legal rights, and you may also have other rights that vary from state to state.

fold here



NO POSTAGE
NECESSARY
IF MAILED
IN THE
UNITED STATES

BUSINESS REPLY MAIL
FIRST-CLASS MAIL PERMIT NO. 4507 DIAMOND BAR CA

POSTAGE WILL BE PAID BY ADDRESSEE

DACOR INC.
ATTN: WARRANTY PROCESSING DEPT
1440 BRIDGE GATE DR STE 200
PO BOX 6532
DIAMOND BAR CA 91765-9861

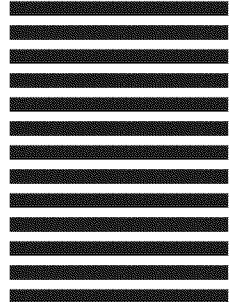



Please visit www.Dacor.com to activate your warranty online.

WARRANTY INFORMATION



IMPORTANT:

Your warranty will not be activated until you activate it online or return this form to Dacor. If you have purchased more than one Dacor product, please return all forms in one envelope or activate the warranty for each product online.

Please rest assured that under no conditions will Dacor sell your name or any of the information on this form for mailing list purposes. We are very grateful that you have chosen Dacor products for your home and do not consider the sale of such information to be a proper way of expressing our gratitude!

Owner's Name: _____
Last (Please Print or Type) First Middle

Street: _____

City: _____ State: _____ Zip: _____

Purchase Date: _____ Email: _____ Telephone: _____

Dealer: _____

City: _____ State: _____ Zip: _____

Your willingness to take a few seconds to fill in the section below will be sincerely appreciated. Thank you.

1. How were you **first** exposed to Dacor products? (Please check one only.)

- A. T.V. Cooking Show
- B. Magazine
- C. Appliance Dealer Showroom
- D. Kitchen Dealer Showroom
- E. Home Show
- F. Builder
- G. Architect/Designer
- H. Another Dacor Owner
- I. Model Home
- J. Other _____

2. Where did you buy your Dacor appliances?

- A. Appliance Dealer
- B. Kitchen Dealer
- C. Builder Supplier
- D. Builder
- E. Other _____

3. For what purpose was the product purchased?

- A. Replacement **only**
- B. Part of a Remodel
- C. New Home
- D. Other _____

4. What is your household income?

- A. Under \$75,000
- B. \$75,000 – \$100,000
- C. \$100,000 – \$150,000
- D. \$150,000 – \$200,000
- E. \$200,000 – \$250,000
- F. Over \$250,000

5. What other brands of appliances do you have in your kitchen?

- A. Cooktop _____
- B. Oven _____
- C. Dishwasher _____
- D. Refrigerator _____

6. Would you buy or recommend another Dacor product?

- Yes
- No

Comments: _____

Thank you very much for your assistance. The information you have provided will be extremely valuable in helping us plan for the future and giving you the support you deserve.

cut here

cut here