

Operator's Manual
26" RIDING MOWER
SIDE DISCHARGE
ELECTRIC START

WEEDEATER[®]
One



Catalog No.
WE261

IMPORTANT:
Read and follow all Safety
Rules and Instructions before
operating this equipment.

Patents Pending

433203

TABLE OF CONTENTS

| | | | |
|------------------------------|----|-------------------------------|----|
| Warranty | 2 | Maintenance | 16 |
| Safety Rules | 3 | Service and Adjustments | 20 |
| Product Specifications | 6 | Storage | 24 |
| Assembly/Pre-Operation | 7 | Troubleshooting | 25 |
| Operation | 10 | Repair Parts | 27 |
| Maintenance Schedule | 16 | | |

WARRANTY

LIMITED WARRANTY

The Manufacturer warrants to the original consumer purchaser that this product as manufactured is free from defects in materials and workmanship. For a period of two (2) years from date of purchase by the original consumer purchaser, we will repair or replace, at our option, without charge for parts or labor incurred in replacing parts any part which we find to be defective due to materials or workmanship. This Warranty is subject to the following limitations and exclusions.

1. This warranty does not apply to the engine, battery (except as noted below) or components parts thereof. Please refer to the applicable manufacturer's warranty on these items.
2. Transportation charges for the movement of any power equipment unit or attachment are the responsibility of the purchaser. Transportation charges for any parts submitted for replacement under this warranty must be paid by the purchaser unless such return is requested by the manufacturer.
3. Battery Warranty: On products equipped with a Battery, we will replace, without charge to you, any battery which we find to be defective in manufacture, during the first ninety (90) days of ownership. After ninety (90) days, we will exchange the Battery, charging you 1/12 of the price of a new Battery for each full month from the date of the original sale. Battery must be maintained in accordance with the instructions furnished.
4. The Warranty does not apply to any products used for rental or commercial purposes.
5. This Warranty applies only to products which have been properly assembled, adjusted, operated, and maintained in accordance with the instructions furnished. This Warranty does not apply to any product which has been subjected to alteration, misuse, abuse, improper assembly or installation, delivery damage, or to normal wear of the product.
6. Exclusions: Excluded from this Warranty are belts, blades, blade adapters, normal wear, normal adjustments, standard hardware and normal maintenance.
7. In the event you have a claim under this Warranty, you must return the product to an authorized service dealer.

Should you have any unanswered questions concerning this Warranty, please contact:

HOP
Outdoor Products Customer Service Dept.
1030 Stevens Creek Road
Augusta, GA 30907 USA

In Canada contact:
HOP
5855 Terry Fox Way
Mississauga, Ontario
L5V 3E4

giving the model number, serial number and date of purchase of your product and the name and address of the authorized dealer from whom it was purchased

THIS WARRANTY DOES NOT APPLY TO INCIDENTAL OR CONSEQUENTIAL DAMAGES AND ANY IMPLIED WARRANTIES ARE LIMITED TO THE SAME TIME PERIODS STATED HEREIN FOR OUR EXPRESSED WARRANTIES. Some areas do not allow the limitation of consequential damages or limitations of how long an implied Warranty may last, so the above limitations or exclusions may not apply to you. This Warranty gives you specific legal rights, and you may have other rights which vary from locale to locale.

This is a limited Warranty within the meaning of that term as defined in the Magnuson-Moss Act of 1975.

SAFETY RULES

DANGER: This cutting machine is capable of amputating hands and feet and throwing objects. Failure to observe the following safety instructions could result in serious injury or death.

⚠️WARNING: In order to prevent accidental starting when setting up, transporting, adjusting or making repairs, always disconnect spark plug wire and place wire where it cannot contact spark plug.

⚠️WARNING: Do not coast down a hill in neutral, you may lose control of the riding mower.

⚠️WARNING: Engine exhaust, some of its constituents, and certain vehicle components contain or emit chemicals known to the State of California to cause cancer and birth defects or other reproductive harm.

⚠️WARNING: This unit is not intended for towing, or use of wheel weights. Only use attachments designed specifically for this riding mower.

⚠️WARNING: Battery posts, terminals and related accessories contain lead and lead compounds, chemicals known to the State of California to cause cancer and birth defects or other reproductive harm. **Wash hands after handling.**

I. GENERAL OPERATION

- Read, understand, and follow all instructions on the machine and in the manual before starting.
- Do not put hands or feet near rotating parts or under the machine. Keep clear of the discharge opening at all times.
- Only allow responsible adults, who are familiar with the instructions, to operate the machine.
- Clear the area of objects such as rocks, toys, wire, etc., which could be picked up and thrown by the blade.
- Be sure the area is clear of bystanders before operating. Stop machine if anyone enters the area.
- Never carry passengers.
- Do not mow in reverse unless absolutely necessary. Always look down and behind before and while backing.

- Never direct discharged material toward anyone. Avoid discharging material against a wall or obstruction. Material may ricochet back toward the operator. Stop the blade when crossing gravel surfaces.
- Do not operate machine without the entire grass catcher, discharge chute, or other safety devices in place and working.
- Slow down before turning.
- Never leave a running machine unattended. Always turn off blade, set parking brake, stop engine, and remove keys before dismounting.
- Disengage blade when not mowing. Shut off engine and wait for all parts to come to a complete stop before cleaning the machine, removing the grass catcher, or unclogging the discharge chute.
- Operate machine only in daylight or good artificial light.
- Do not operate the machine while under the influence of alcohol or drugs.
- Watch for traffic when operating near or crossing roadways.
- Use extra care when loading or unloading the machine into a trailer or truck.
- Always wear eye protection when operating machine.
- Data indicates that operators, age 60 years and above, are involved in a large percentage of riding mower-related injuries. These operators should evaluate their ability to operate the riding mower safely enough to protect themselves and others from serious injury.
- Keep machine free of grass, leaves or other debris build-up which can touch hot exhaust / engine parts and burn. Do not allow the mower deck to plow leaves or other debris which can cause build-up to occur. Clean any oil or fuel spillage before operating or storing the machine. Allow machine to cool before storage.

SAFETY RULES

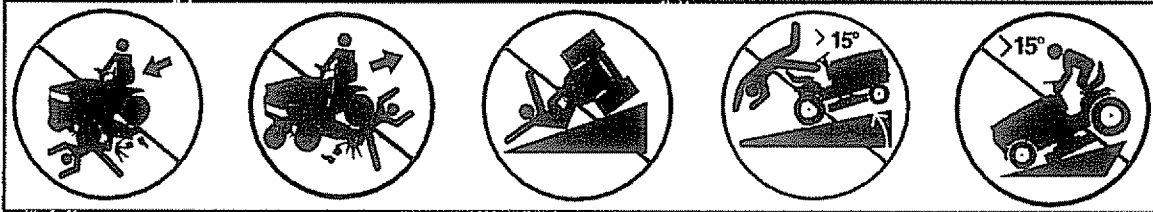

II. SLOPE OPERATION

Slopes are a major factor related to loss of control and tip-over accidents, which can result in severe injury or death. Operation on all slopes requires extra caution. If you cannot back up the slope or if you feel uneasy on it, do not mow it.

- Mow up and down slopes (15° Max), not across.
- Watch for holes, ruts, bumps, rocks, or other hidden objects. Uneven terrain could overturn the machine. Tall grass can hide obstacles.
- Choose a low ground speed so that you will not have to stop or shift while on the slope.
- Do not mow on wet grass. Tires may lose traction.
- Always keep the machine in gear when going down slopes. Do not shift to neutral and coast downhill.
- If machine stops while going uphill, disengage blade, shift into reverse and back down slowly.
- Avoid starting, stopping, or turning on a slope. If the tires lose traction, disengage the blade and proceed slowly straight down the slope.
- Keep all movement on the slopes slow and gradual. Do not make sudden changes in speed or direction, which could cause the machine to roll over.
- Use extra care while operating machine with grass catchers or other attachments; they can affect the stability of the machine.
- Do not use on steep slopes.
- Do not try to stabilize the machine by putting your foot on the ground.
- Do not mow near drop-offs, ditches, or embankments. The machine could suddenly roll over if a wheel is over the edge or if the edge caves in.

III. CHILDREN

Tragic accidents can occur if the operator is not alert to the presence of children. Children are often attracted to the machine and the mowing activity. Never assume that children will remain where you last saw them.

- Keep children out of the mowing area and in the watchful care of a responsible adult other than the operator.
- Be alert and turn machine off if a child enters the area.
- Before and while backing, look behind and down for small children.
- Never carry children, even with the blade shut off. They may fall off and be seriously injured or interfere with safe machine operation. Children who have been given rides in the past may suddenly appear in the mowing area for another ride and be run over or backed over by the machine.
- Never allow children to operate the machine.
- Use extra care when approaching blind corners, shrubs, trees, or other objects that may block your view of a child.

IV. SERVICE

SAFE HANDLING OF GASOLINE

To avoid personal injury or property damage, use extreme care in handling gasoline. Gasoline is extremely flammable and the vapors are explosive.

- Extinguish all cigarettes, cigars, pipes, and other sources of ignition.
- Use only approved gasoline container.
- Never remove gas cap or add fuel with the engine running. Allow engine to cool before refueling.
- Never fuel the machine indoors.
- Never store the machine or fuel container where there is an open flame, spark, or pilot light such as on a water heater or other appliances.

SAFETY RULES

- Never fill containers inside a vehicle or on a truck or trailer bed with plastic liner. Always place containers on the ground away from your vehicle when filling.
- Remove gas-powered equipment from the truck or trailer and refuel it on the ground. If this is not possible, then refuel such equipment with a portable container, rather than from a gasoline dispenser nozzle.
- Keep the nozzle in contact with the rim of the fuel tank or container opening at all times until fueling is complete. Do not use a nozzle lock-open device.
- If fuel is spilled on clothing, change clothing immediately.
- Never overfill fuel tank. Replace gas cap and tighten securely.
- If you strike a foreign object, stop and inspect the machine. Repair, if necessary, before restarting.
- Never make any adjustments or repairs with the engine running.
- Check grass catcher components and the discharge chute frequently and replace with manufacturer's recommended parts, when necessary.
- Mower blade is sharp. Wrap the blade or wear gloves, and use extra caution when servicing them.
- Check brake operation frequently. Adjust and service as required.
- Maintain or replace safety and instruction labels, as necessary.
- Be sure the area is clear of bystanders before operating. Stop machine if anyone enters the area.
- Never carry passengers.
- Do not mow in reverse unless absolutely necessary. Always look down and behind before and while backing.

GENERAL SERVICE

- Never operate machine in a closed area.
- Keep all nuts and bolts tight to be sure the equipment is in safe working condition.
- Never tamper with safety devices. Check their proper operation regularly.
- Keep machine free of grass, leaves, or other debris build-up. Clean oil or fuel spillage and remove any fuel-soaked debris. Allow machine to cool before storing.

PRODUCT SPECIFICATIONS

| | |
|-----------------------------|--|
| Gasoline Capacity and Type: | 1.2 qt. Unleaded Regular |
| Oil Type (API-SG-SL): | SAE 30 (above 32°F) SAE 5W-30(below 32°F) |
| Oil Capacity: | 20 oz. |
| Spark Plug: | Champion RC12YC (Gap: .030") |
| Ground Speed | Forward: 0-4 mph Reverse: 0-1 mph |
| Blade Bolt Torque: | 45-55 Ft. Lbs. |

CUSTOMER RESPONSIBILITIES

- Read and observe the safety rules.
- Follow a regular schedule in maintaining, caring for and using your riding mower.
- Follow the instructions under "Maintenance" and "Storage" sections of this owner's manual.

⚠ WARNING: This riding mower is equipped with an internal combustion engine and should not be used on or near any unimproved forest-covered, brush-covered or grass-covered land unless the engine's exhaust system is equipped with a spark arrester meeting applicable local or state laws (if any). If a spark arrester is used, it should be maintained in effective working order by the operator.

In the state of California the above is required by law (Section 4442 of the California Public Resources Code). Other states may have similar laws. Federal laws apply on federal lands. A spark arrester for the muffler is available through your nearest authorized service center.

UNASSEMBLED PARTS

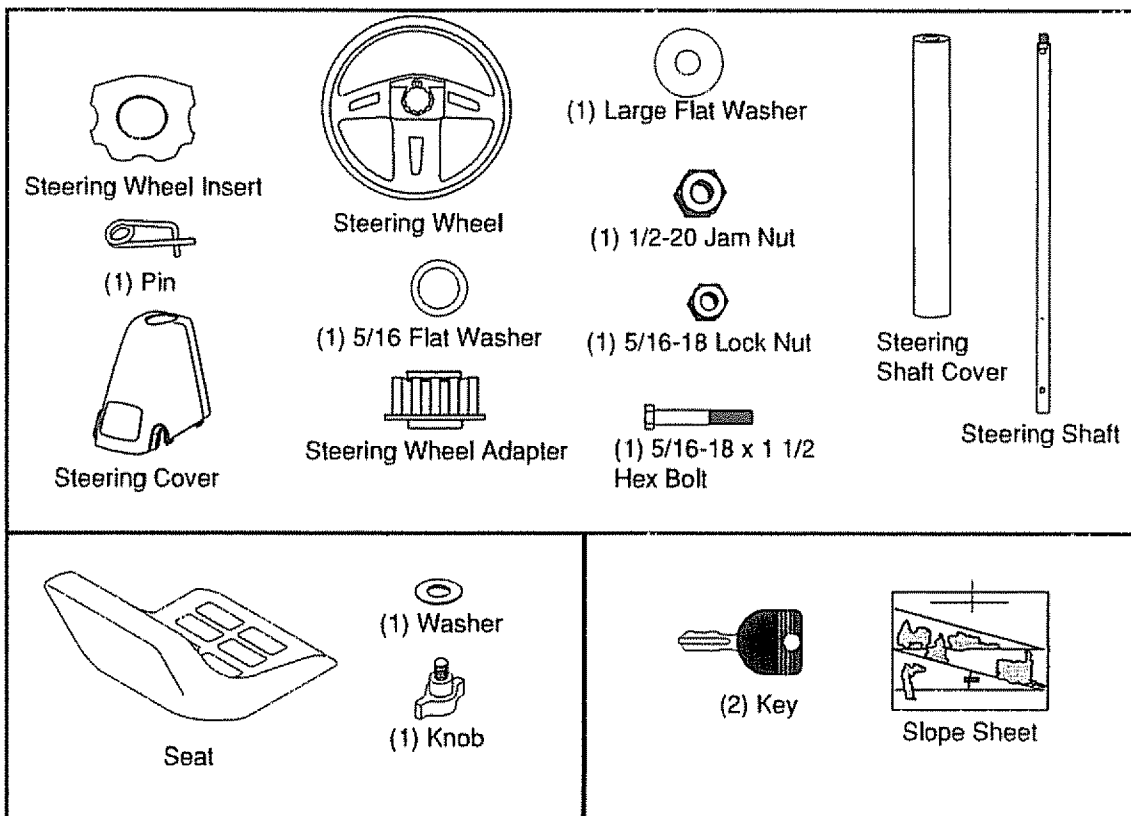

ASSEMBLY/PRE-OPERATION

Your new riding mower has been assembled at the factory with the exception of those parts left unassembled for shipping purposes. To ensure safe and proper operation of your riding mower all parts and hardware you assemble must be tightened securely. Use the correct tools as necessary to insure proper tightness.

TOOLS REQUIRED FOR ASSEMBLY

A socket wrench set will make assembly easier. Standard wrench sizes you need are listed below.

- (1) 3/4" wrench
- (1) 1/2" wrench
- (1) Utility knife
- (1) Tire pressure gauge

When right or left hand is mentioned in this manual, it means when you are in the operating position (seated behind the steering wheel).

TO REMOVE RIDING MOWER FROM CARTON

UNPACK CARTON

1. Cut along dotted lines on all four panels of carton. Remove carton and top frame as one unit.
2. Remove packing materials from riding mower.

NOTE: Only cut carton with a short blade utility knife, a long blade or saw can puncture tires on unit.

HOW TO SET UP YOUR RIDING MOWER

INSTALL STEERING COLUMN

1. Insert steering shaft into mount and securely fasten with bolt, washer, and nut provided.
2. Insert pin into hole in steering shaft.
3. Slide plastic cover over steering shaft and into position.

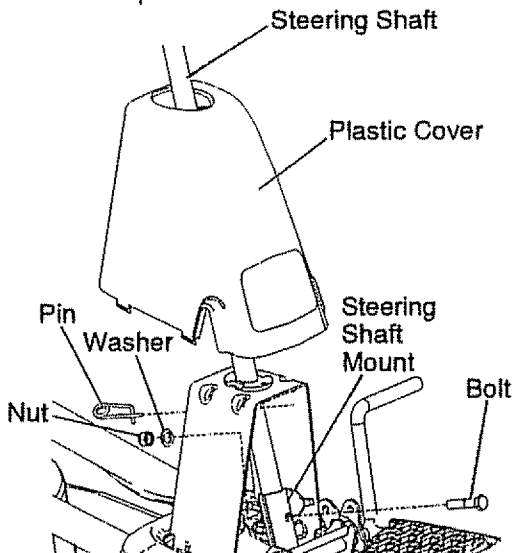

4. Slide steering shaft protective foam cover over shaft.
5. Position front wheels of the riding mower so they are pointing straight forward.

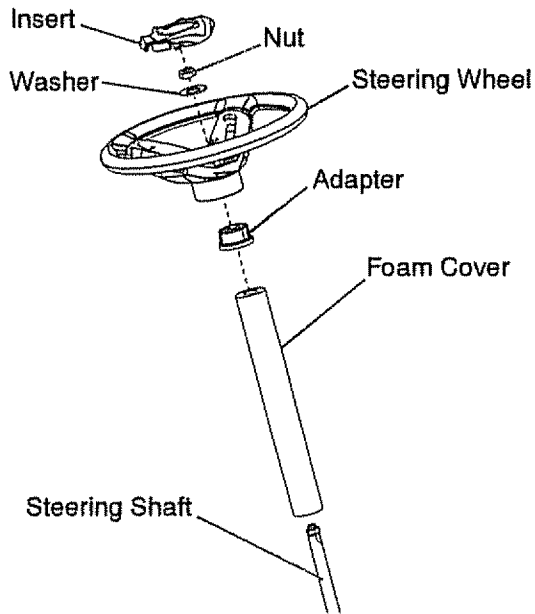

6. Remove steering wheel adapter from steering wheel and slide adapter onto steering shaft.
7. Press steering wheel into position on shaft, install large washer, and tighten nut securely.
8. Snap steering wheel insert into center of steering wheel securely.

INSTALL SEAT

1. Pivot seat upward and remove from the cardboard packing. Remove the cardboard packing and discard.
2. Place seat on seat pan so head of shoulder bolt is positioned over large slotted hole in pan.
3. Push down on seat to engage shoulder bolt in slot and pull seat towards rear of riding mower.

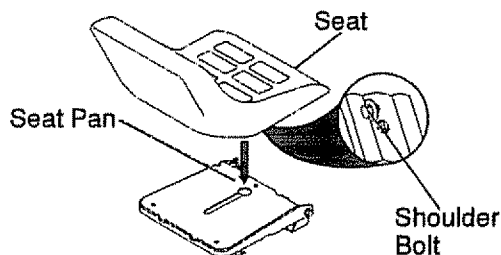

- Pivot seat and pan forward and assemble adjustment knob and flat washer loosely. Do not tighten.

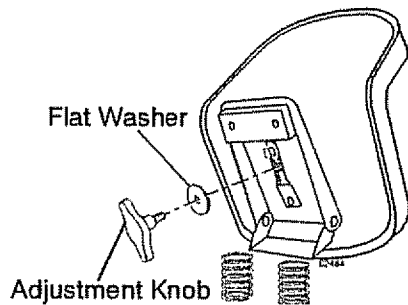

- Lower seat into operating position and sit in seat.
- Slide seat until a comfortable position is reached which allows you to press clutch/brake pedal all the way down.
- Get off seat without moving its adjusted position.
- Raise seat and tighten adjustment knob securely.

CHECK BATTERY

Make sure battery is securely fastened, and that all wires are securely connected.

- Battery is located under the seat.
- Battery has been fully charged from the factory, before installation.

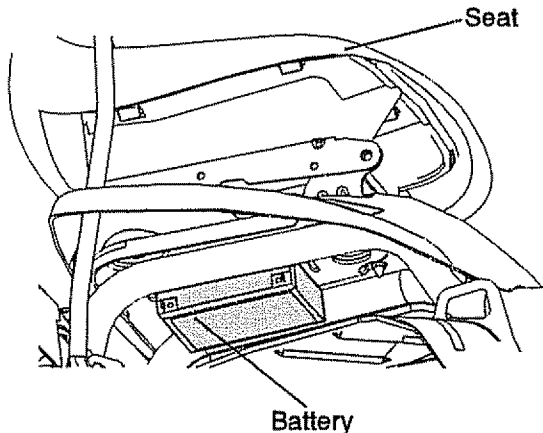

NOTE: Battery should only be charged using charger specified in "BATTERY" section in the service and adjustments section of this manual. Charger can be purchased at your local service center.

NOTE: You may now roll your riding mower off the skid. Follow the appropriate instruction below to remove the riding mower from the skid.

WARNING: Before starting, read, understand and follow all instructions in the Operation section of this manual. Be sure riding mower is in a well-ventilated area. Be sure the area in front of riding mower is clear of other people and objects.

TO ROLL RIDING MOWER OFF SKID (See Operation section for location and function of controls)

- Raise deck lift lever to its highest position.
- Release parking brake by depressing clutch/brake pedal.
- Engage freewheel control. See "TO TRANSPORT" in the operation section of this manual.
- Roll riding mower forward off skid.

CHECK TIRE PRESSURE

The tires on your riding mower were overinflated at the factory for shipping purposes. Correct tire pressure is important for best cutting performance.

- Reduce tire pressure to PSI shown on tires.

CHECK DECK LEVELNESS

For best cutting results, mower housing should be properly leveled. See "TO LEVEL MOWER HOUSING" in the Service and Adjustments section of this manual.

CHECK FOR PROPER POSITION OF MOWER DRIVE BELT

See the figure that is shown for replacing the mower drive belt in the service and adjustment section of this manual. Verify that the belt is routed correctly.

CHECK BRAKE SYSTEM

After you learn how to operate your riding mower, check to see that the brake is operating properly. See "TO ADJUST BRAKE" in the Service and Adjustments section of this manual.

✓ CHECKLIST

Before you operate your new riding mower, we wish to assure that you receive the best performance and satisfaction from this Quality Product.

Please review the following checklist:

- ✓ All assembly instructions have been completed.
- ✓ No remaining loose parts in carton.
- ✓ Battery is properly connected.
- ✓ Seat is adjusted comfortably and tightened securely.
- ✓ All tires are properly inflated. (For shipping purposes, the tires were overinflated at the factory).
- ✓ Be sure mower deck is properly leveled side-to-side/front-to-rear for best cutting results. (Tires must be properly inflated for leveling).
- ✓ Check mower belt. Be sure it is routed properly around pulleys and inside all belt keepers.
- ✓ Check wiring. See that all connections are still secure and wires are properly clamped.
- ✓ Before driving riding mower, be sure free-wheel control is in "transmission engaged" position (see "TO TRANSPORT" in the Operation section of this manual).

While learning how to use your riding mower, pay extra attention to the following important items:





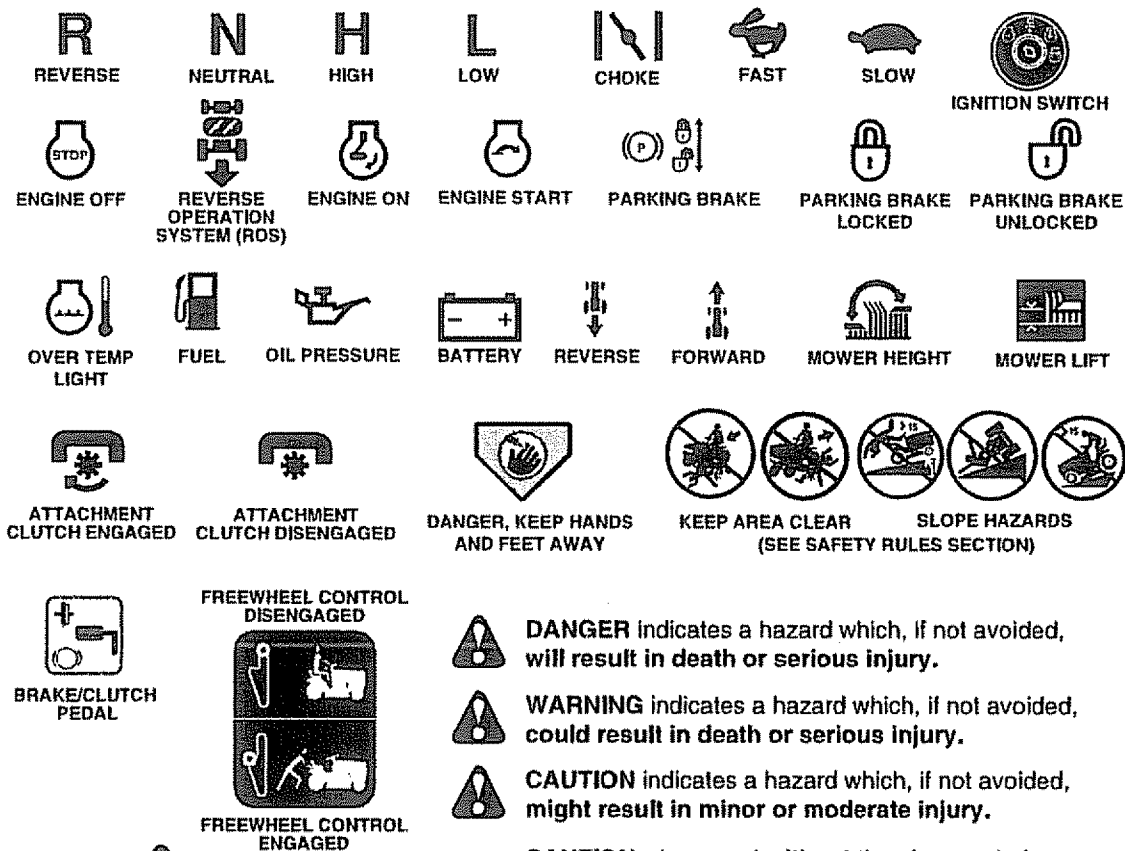

- ✓ Engine oil is at proper level.
- ✓ Fuel tank is filled with fresh, clean, regular unleaded gasoline.
- ✓ Become familiar with all controls, their location and function. Operate them before you start the engine.
- ✓ Be sure brake system is in safe operating condition.
- ✓ Be sure Operator Presence System and Reverse Operation System (ROS) are working properly (See the Operation and Maintenance sections in this manual).

OPERATION

These symbols may appear on your riding mower or in literature supplied with the product. Learn and understand their meaning.



Failure to follow instructions could result in serious injury or death. The safety alert symbol is used to identify safety information about hazards which can result in death, serious injury and/or property damage.

-  **DANGER** indicates a hazard which, if not avoided, will result in death or serious injury.
-  **WARNING** indicates a hazard which, if not avoided, could result in death or serious injury.
-  **CAUTION** indicates a hazard which, if not avoided, might result in minor or moderate injury.
-  **CAUTION** when used without the alert symbol, indicates a situation that could result in damage to the tractor and/or engine.
-  **HOT SURFACES** indicates a hazard which, if not avoided, could result in death, serious injury and/or property damage.
-  **FIRE** indicates a hazard which, if not avoided, could result in death, serious injury and/or property damage.

KNOW YOUR RIDING MOWER

READ THIS OWNER'S MANUAL AND SAFETY RULES BEFORE OPERATING YOUR RIDING MOWER

Compare the illustrations with your riding mower to familiarize yourself with the locations of various controls and adjustments. Save this manual for future reference.

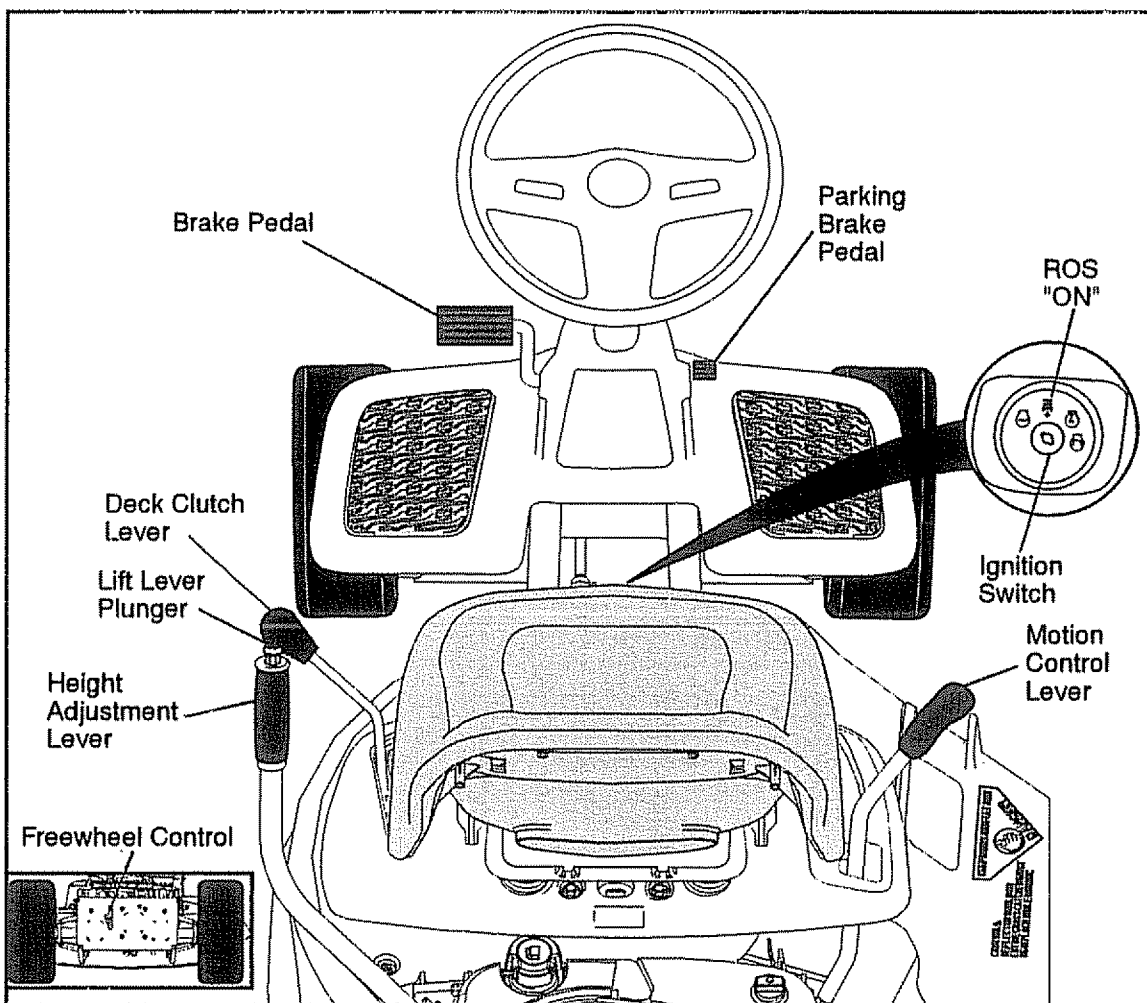

Our riding mowers conform to the applicable safety standards of the American National Standards Institute.

DECK CLUTCH LEVER - Used to engage the mower blade.

BRAKE PEDAL - Used for braking the riding mower and starting the engine.

HEIGHT ADJUSTMENT LEVER - Used to adjust mower cutting height.

IGNITION SWITCH - Used for starting and stopping the engine.

LIFT LEVER PLUNGER - Used to release height adjustment lever when changing its position.

PARKING BRAKE LEVER - Locks parking brake into brake position.

MOTION CONTROL LEVER - Selects the speed and direction of the riding mower.

FREEWHEEL CONTROL - Disengages transmission for pushing or slowly towing the riding mower with the engine off.

ROS "ON" POSITION - Allows operation of mower deck or other powered attachment while in reverse.



The operation of any riding mower can result in foreign objects thrown into the eyes, which can result in severe eye damage. Always wear safety glasses or eye shields while operating your riding mower or performing any adjustments or repairs. We recommend a wide vision safety mask over spectacles or standard safety glasses.

HOW TO USE YOUR RIDING MOWER

TO SET PARKING BRAKE

Your riding mower is equipped with an operator presence sensing switch. When engine is running, any attempt by the operator to leave the seat without first setting the parking brake will shut off the engine.

1. Depress brake pedal all the way down and hold.
2. Depress parking brake lever and release pressure from brake pedal. Pedal should remain in brake position. Make sure parking brake will hold riding mower secure.

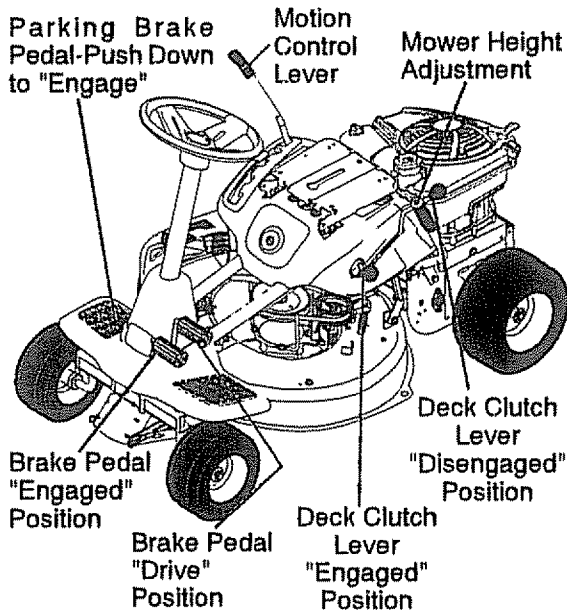

STOPPING

MOWER BLADE -

- To stop mower blade, move deck clutch lever to disengaged position.

GROUND DRIVE -

- To stop ground drive, depress brake pedal all the way down.

ENGINE -

- Turn ignition key to "STOP" position and remove key. Always remove key when leaving riding mower to prevent unauthorized use.

IMPORTANT: Leaving the ignition switch in any position other than "STOP" will cause the battery to discharge and go dead.

NOTE: Under certain conditions when riding mower is standing idle with the engine running, hot engine exhaust gases may cause "browning" of grass. To eliminate this possibility, always stop engine when stopping riding mower on grass areas.

CAUTION: Always stop riding mower completely, as described above, before leaving the operator's position.

TO MOVE FORWARD AND BACKWARD

The direction and speed of movement is controlled by the motion control lever.

1. Start riding mower with clutch/brake pedal depressed and motion control lever in neutral (N) position.
2. Move motion control lever to desired position.
3. Slowly release clutch/brake pedal to start movement.

IMPORTANT: Bring riding mower to a complete stop before shifting or changing gears. Failure to do so will shorten the useful life of your transaxle.

TO ADJUST MOWER CUTTING HEIGHT

The position of the mower height deck lift lever determines the cutting height.

- Grasp lift lever.
- Press lift lever plunger with thumb and move lever to desired position.

The cutting height range is approximately 1-1/2 to 4". The heights are measured from the ground to the blade tip with the engine not running. These heights are approximate and may vary depending upon soil conditions, height of grass and types of grass being mowed.

- The average lawn should be cut to approximately 2-1/2" during the cool season and to over 3" during hot months. For healthier and better looking lawns, mow often and after moderate growth.
- For best cutting performance, grass over 6" in height should be mowed twice. Make the first cut relatively high; the second to desired height.

TO OPERATE MOWER

Your riding mower is equipped with an operator presence sensing switch. Any attempt by the operator to leave the seat with the engine running and the deck clutch engaged will shut off the engine. You must remain fully and centrally positioned in the seat to prevent the engine from hesitating or cutting off when operating your equipment on rough, rolling terrain or hills.

1. Select desired height of cut.
2. Start mower blade by engaging deck clutch lever.

TO STOP MOWER BLADE-

Disengage deck clutch lever.

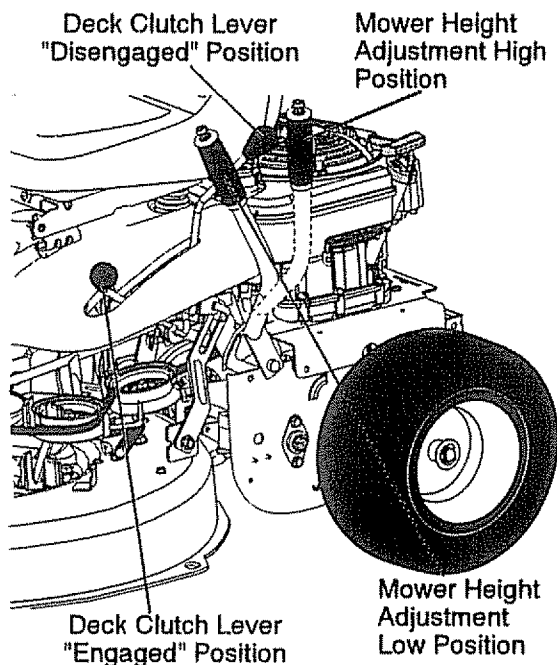

CAUTION: Do not operate the mower without either the entire grass catcher, on mowers so equipped, or the deflector shield in place.

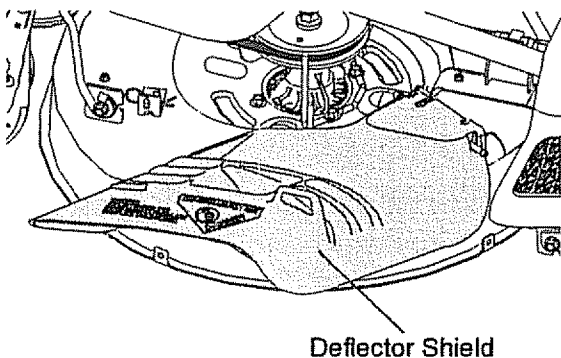

REVERSE OPERATION SYSTEM (ROS)

Your tractor is equipped with a Reverse Operation System (ROS). Any attempt by the operator to travel in the reverse direction with the deck clutch engaged will shut off the engine unless ignition key is placed in the ROS "ON" position.

WARNING: Backing up with the deck clutch engaged while mowing is strongly discouraged. Turning the ROS "ON", to allow reverse operation with the deck clutch engaged, should only be done when the operator decides it is necessary to reposition the machine with the attachment engaged. **Do not mow in reverse unless absolutely necessary.**

USING THE REVERSE OPERATION SYSTEM -

Only use if you are certain no children or other bystanders will enter the mowing area.

1. Move motion control lever to neutral (N) position.
2. With engine running, turn ignition key counterclockwise to ROS "ON" position.
3. Look down and behind before and while backing.
4. Slowly move motion control lever to reverse (R) position to start movement.
5. When use of the ROS is no longer needed, turn the ignition key clockwise to engine "ON" position.

ROS "ON" Position

Engine "ON" Position (Normal Operating)

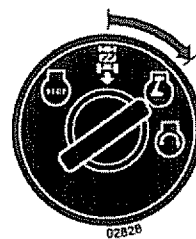
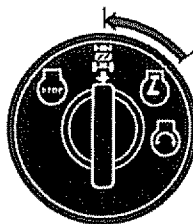

TO OPERATE ON HILLS

⚠ WARNING: Do not drive up or down hills with slopes greater than 15° and do not drive across any slope. Use the slope guide at the back of this manual.

- Choose the slowest speed before starting up or down hills.
- Avoid stopping or changing speed on hills.
- If stopping is absolutely necessary, push clutch/brake pedal quickly to brake position and engage parking brake.
- Move motion control lever to neutral (N) position.
- To restart movement, slowly release parking brake and clutch/brake pedal.
- Make all turns slowly.

TO TRANSPORT

When pushing or towing your riding mower, be sure to disengage transmission by placing freewheel control in freewheel position. Freewheel control is located at the rear drawbar of the riding mower.

- Raise mower height adjustment to its highest position with mower height adjustment lever.
- Push freewheel control down and over with foot.

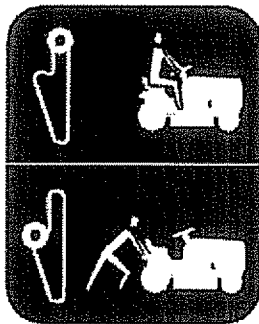

Freewheel
Control
Disengaged

Freewheel
Control
Engaged

- To reengage transmission, reverse above procedure, or press brake lever all the way down.

BEFORE STARTING THE ENGINE

CHECK ENGINE OIL LEVEL

The engine in your riding mower has been shipped, from the factory, already filled with summer weight oil.

1. Check engine oil with riding mower on level ground.
2. Remove oil fill cap/dipstick and wipe clean, reinsert the dipstick and screw cap tight, wait for a few seconds, remove and read oil level. If necessary, add oil until "FULL" mark on dipstick is reached. Do not overfill.

- For cold weather operation you should change oil for easier starting (See the oil viscosity chart in the Maintenance section of this manual).
- To change engine oil, see the Maintenance section in this manual.

ADD GASOLINE

- Fill fuel tank to bottom of filler neck. Do not overfill. Use fresh, clean, regular unleaded gasoline with a minimum of 87 octane. (Use of leaded gasoline will increase carbon and lead oxide deposits and reduce valve life). Do not mix oil with gasoline. Purchase fuel in quantities that can be used within 30 days to assure fuel freshness.

⚠ CAUTION: Wipe off any spilled oil or fuel. Do not store, spill or use gasoline near an open flame.

⚠ CAUTION: Alcohol blended fuels (called gasohol or using ethanol or methanol) can attract moisture which leads to separation and formation of acids during storage. Acidic gas can damage the fuel system of an engine while in storage. To avoid engine problems, the fuel system should be emptied before storage of 30 days or longer. Drain the gas tank, start the engine and let it run until the fuel lines and carburetor are empty. Use fresh fuel next season. See Storage Instructions for additional information. Never use engine or carburetor cleaner products in the fuel tank or permanent damage may occur.

TO START ENGINE

When starting the engine for the first time or if the engine has run out of fuel, it will take extra cranking time to move fuel from the tank to the engine.

1. Be sure freewheel control is in the transmission engaged position.
2. Sit on seat in operating position, depress clutch/brake pedal and set parking brake.
3. Place motion control lever in neutral (N) position.
4. Move deck clutch to disengaged position.
5. Insert key into ignition and turn key clockwise to start position and release key as soon as engine starts. Do not run starter continuously for more than fifteen seconds per minute.

NOTE: If at high altitude (above 3000 feet) or in cold temperature (below 32°F) the fuel mixture may need to be adjusted for best performance.

RECOIL STARTING SYSTEM

This unit is equipped with an engine recoil starting system. If the battery is too weak to start engine.

1. Set parking Brake.
2. Turn key to ON position.
3. Make sure unit is in neutral position.
4. Set deck to disengaged position.
5. Pull recoil cord to start engine.

Gasoline Filler
Cap

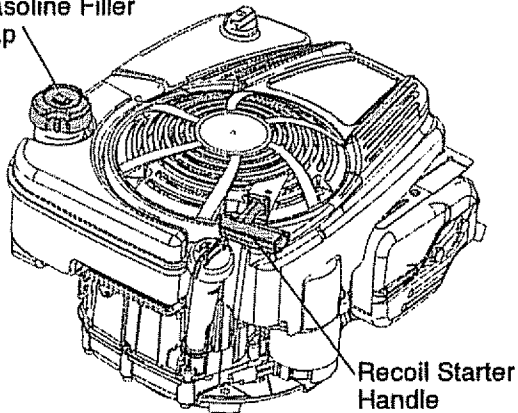

- Do not mow grass when it is wet. Wet grass will plug mower and leave undesirable clumps. Allow grass to dry before mowing.
- Regulate ground speed by selecting a low enough gear to give the mower cutting performance as well as the quality of cut desired.
- When operating attachments, select a ground speed that will suit the terrain and give best performance of the attachment being used.

MOWING TIPS

- Mower should be properly leveled for best mowing performance. See "TO LEVEL MOWER HOUSING" in the Service and Adjustments section of this manual.
- The left hand side of mower should be used for trimming.
- Drive so that clippings are discharged onto the area that has already been cut. Have the cut area to the right of the riding mower. This will result in a more even distribution of clippings and more uniform cutting.

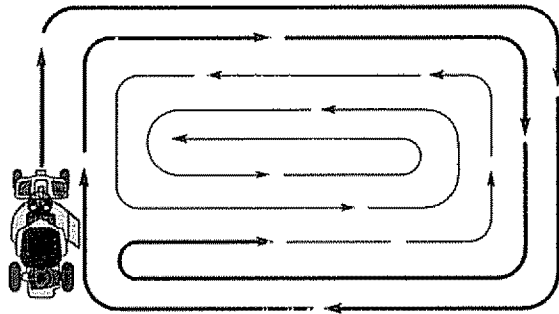

- When mowing large areas, start by turning to the right so that clippings will discharge away from shrubs, fences, driveways, etc. After one or two rounds, mow in the opposite direction making left hand turns until finished.
- If grass is extremely tall, it should be mowed twice to reduce load and possible fire hazard from dried clippings. Make first cut relatively high; the second to the desired height.

MAINTENANCE

| MAINTENANCE SCHEDULE | | BEFORE EACH USE | EVERY 8 HOURS | EVERY 25 HOURS | EVERY 50 HOURS | EVERY 100 HOURS | EVERY SEASON | BEFORE STORAGE |
|------------------------------------|---------------------------------------|-----------------|---------------|------------------|----------------|-----------------|--------------|----------------|
| RIDING MOWER | Check Brake Operation | ✓ | ✓ | | | | | |
| | Check Tire Pressure | ✓ | ✓ | | | | | |
| | Check Operator Presence & ROS Systems | ✓ | | | | | | |
| | Check for Loose Fasteners | ✓ | | | | ✓ | | ✓ |
| | Check/Replace Mower Blade | | | ✓ ³ | | | | |
| | Clean Battery and Terminals | | | ✓ | | | | ✓ |
| | Lubricate Axles and Spindles | | | ✓ | | | | |
| | Check Transaxle Cooling | | | ✓ | | | | ✓ |
| | Check Mower Levelness | | | | ✓ | | | |
| | Check V-Belt | | | | | ✓ | | |
| Oil Drive Chains | | | ✓ | | | | | |
| ENGINE | Check Engine Oil Level | ✓ | ✓ | | | | | |
| | Change Engine Oil | | | ✓ ^{1,2} | | | | ✓ |
| | Clean Air Filter | | | ✓ ² | | | | |
| | Clean Air Screen | | | ✓ ² | | | | |
| | Inspect Muffler/Spark Arrester | | | | ✓ | | | |
| | Clean Engine Cooling Fins | | | | | ✓ ² | | |
| | Replace Spark Plug | | | | | ✓ | ✓ | |
| Replace Air Filter Paper Cartridge | | | | | ✓ ² | | | |

1 - Change more often when operating under a heavy load or in high ambient temperatures
 2 - Service more often when operating in dirty or dusty conditions

3 - Replace blade more often when mowing in sandy soil

GENERAL RECOMMENDATIONS

The warranty on this riding mower does not cover items that have been subjected to operator abuse or negligence. To receive full value from the warranty, operator must maintain riding mower as instructed in this manual.

Some adjustments will need to be made periodically to properly maintain your riding mower.

At least once a season, check to see if you should make any of the adjustments described in the Service and Adjustments section of this manual.

- At least once a year you should replace the spark plug, clean or replace air filter, and check blade and belt for wear. A new spark plug and clean air filter assure proper air-fuel mixture and help your engine run better and last longer.

BEFORE EACH USE

1. Check engine oil level.
2. Check brake operation.
3. Check tire pressure.
4. Check operator presence and ROS systems for proper operation.
5. Check for loose fasteners.

IMPORTANT: Do not oil or grease the pivot points which have special nylon bearings. Viscous lubricants will attract dust and dirt that will shorten the life of the self-lubricating bearings. If you feel they must be lubricated, use only a dry, powdered graphite type lubricant sparingly.

RIDING MOWER

Always observe safety rules when performing any maintenance.

BRAKE OPERATION

If riding mower requires more than four (4) feet to stop at highest speed in highest gear on a level, dry concrete or paved surface, then brake must be serviced. (See "TO ADJUST BRAKE" in the Service and Adjustments section of this manual).

TIRES

- Maintain proper air pressure in all tires (See PSI on tires).
- Keep tires free of gasoline, oil, or insect control chemicals which can harm rubber.
- Avoid stumps, stones, deep ruts, sharp objects and other hazards that may cause tire damage.

NOTE: To seal tire punctures and prevent flat tires due to slow leaks, tire sealant may be purchased from your local parts dealer. Tire sealant also prevents tire dry rot and corrosion.

AXLE AND SPINDLES

- Front wheel axles and front spindles should be properly lubricated.
- Wheel Axles should be lubricated with a dry, powdered graphite type lubricant.
- Spindles should be lubricated with a spray type silicone base lubricant.

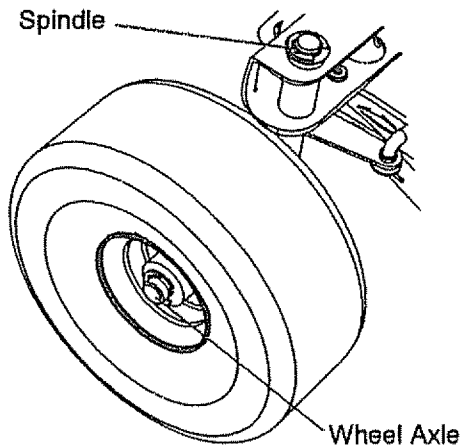

OPERATOR PRESENCE SYSTEM AND REVERSE OPERATION SYSTEM (ROS)

Be sure operator presence and reverse operation systems are working properly. If your riding mower does not function as described, repair the problem immediately.

- The engine should not start unless the brake pedal is fully depressed, and the deck clutch lever is in the disengaged position.

CHECK OPERATOR PRESENCE SYSTEM

- When the engine is running, any attempt by the operator to leave the seat without first setting the parking brake should shut off the engine.
- When the engine is running and the deck clutch lever is engaged, any attempt by the operator to leave the seat should shut off the engine.
- The deck clutch lever should never operate unless the operator is in the seat.

CHECK REVERSE OPERATION (ROS) SYSTEM

- When the engine is running with the ignition switch in the engine "ON" position and the deck clutch lever engaged, any attempt by the operator to shift into reverse should shut off the engine.
- When the engine is running with the ignition switch in the ROS "ON" position and the deck clutch lever engaged, any attempt by the operator to shift into reverse should NOT shut off the engine.

BLADE CARE

For best results mower blades must be sharp. Replace worn, bent or damaged blades.

CAUTION: Use only a replacement blade approved by the manufacturer of your riding mower. Using a blade not approved by the manufacturer of your riding mower is hazardous, could damage your riding mower and void your warranty.

ROS "ON" Position

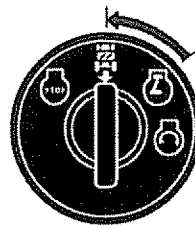

Engine "ON" Position (Normal Operating)

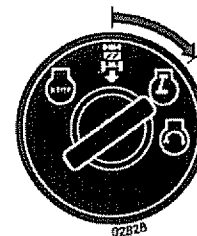

BLADE REMOVAL

1. Raise mower to highest position to allow access to blade.

NOTE: Protect your hands with gloves and/or wrap blade with heavy cloth.

2. Remove blade bolt by turning counter-clockwise.
3. Install new blade with stamped "THIS SIDE UP" facing deck and mandrel assembly.

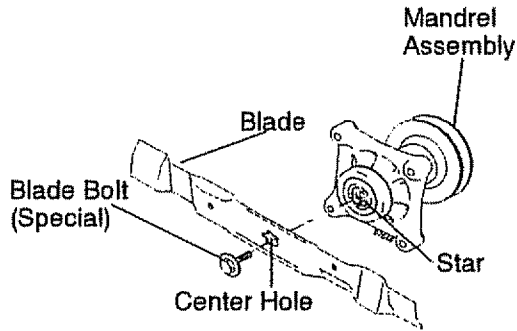

IMPORTANT: To ensure proper assembly, center hole in blade must align with star on mandrel assembly.

4. Install and tighten blade bolt securely (45-55 Ft. Lbs.).

IMPORTANT: Special blade bolt is heat treated.

BATTERY

Your riding mower has a battery charging system which is sufficient for normal use.

- Keep battery and connectors clean.
- Only recharge battery with charger approved for a 12V 2.8 amp. hour battery.
- Charging with any other charger or an automotive style charger can cause permanent damage to the battery.
- Charge battery for 24 hours for a full charge.

NOTE: The original equipment battery on your riding mower is maintenance free. Do not attempt to open or remove caps or covers. Adding or checking level of electrolyte is not necessary.

WARNING: Do not jump start battery. Permanent damage to the battery or personal injury may occur.

TRANSAXLE COOLING

Keep transaxle free from build-up of dirt and chaff which can restrict cooling.

V-BELT

Check V-belt for deterioration and wear after 100 hours of operation and replace if necessary. The belt is not adjustable. Replace belt if it begins to slip from wear.

ENGINE

LUBRICATION

Only use high quality detergent oil rated with API service classification SG-SL. Select the oil's SAE viscosity grade according to your expected operating temperature.

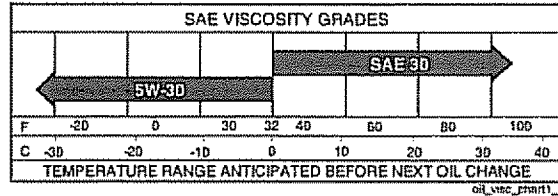

NOTE: Although multi-viscosity oils (5W30, 10W30 etc.) improve starting in cold weather, the oils will result in increased oil consumption when used above 32°F. Check your engine oil level more frequently to avoid possible engine damage from running low on oil. Change the oil after every 25 hours of operation or at least once a year if the riding mower is not used for 25 hours in one year.

Check the crankcase oil level before starting the engine and after each eight (8) hours of operation. Tighten oil fill cap/dipstick securely each time you check the oil level.

TO CHANGE ENGINE OIL

Determine temperature range expected before oil change. All oil must meet API service classification SG-SL.

- Be sure riding mower is on level surface.
 - Oil will drain more freely when warm.
 - Oil can be pumped from the engine with a mechanical or electric siphon pump.
1. Remove oil fill cap/dipstick. Be careful not to allow dirt to enter the engine when changing oil.
 2. Insert end of pump into oil reservoir.
 3. Pump oil from reservoir.

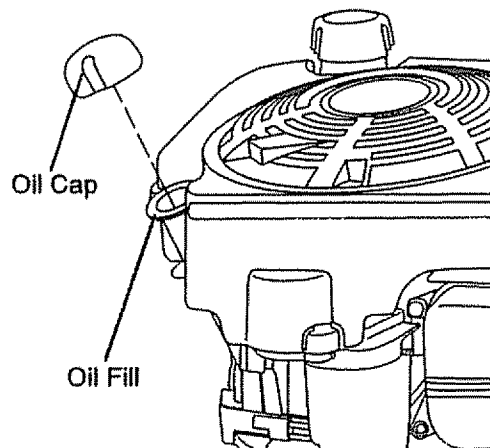

4. Refill engine with oil through oil fill dipstick tube. Pour slowly. Do not overfill. For approximate capacity see "PRODUCT SPECIFICATIONS" section of this manual.
5. Use gauge on oil fill cap/dipstick for checking level. For accurate reading, tighten dipstick cap securely onto the tube before removing dipstick. Keep oil at "FULL" line on dipstick. Tighten cap onto the tube securely when finished.

AIR FILTER

Your engine will not run properly using a dirty air filter. Replace the air filter every 100 hours of operation or every season, whichever occurs first. Service air cleaner more often under dusty conditions.

1. Remove cover knob and cover.
2. Carefully remove cartridge.
3. Clean base carefully to prevent debris from falling into carburetor.
4. Clean by gently tapping on a flat surface.
5. Reinstall cartridge, cover and secure with cover knob.

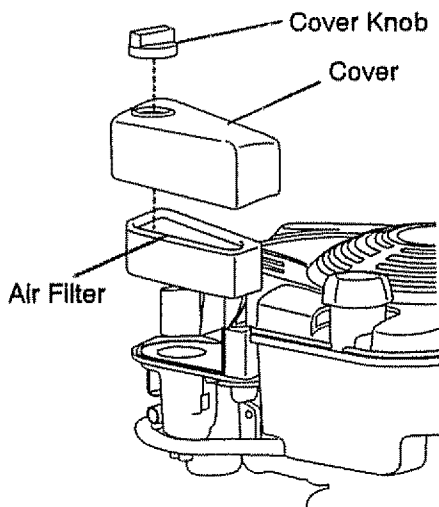

NOTE: If very dirty or damaged, replace cartridge.

IMPORTANT: Petroleum solvents, such as kerosene, are not to be used to clean the cartridge. They may cause deterioration of the cartridge. Do not oil cartridge. Do not use pressurized air to clean cartridge.

CLEAN AIR SCREEN

Air screen must be kept free of dirt and chaff to prevent engine damage from overheating. Clean with a wire brush or compressed air to remove dirt and stubborn dried gum fibers.

CLEAN AIR INTAKE/COOLING AREAS

To ensure proper cooling, make sure the grass screen, cooling fins, and other external surfaces of the engine are kept clean at all times.

Every 100 hours of operation (more often under extremely dusty, dirty conditions), remove the blower housing and other cooling shrouds. Clean the cooling fins and external surfaces as necessary. Make sure the cooling shrouds are reinstalled.

NOTE: Operating the engine with a blocked grass screen, dirty or plugged cooling fins, and/or cooling shrouds removed will cause engine damage due to overheating.

MUFFLER

Inspect and replace corroded muffler and spark arrester (if equipped) as it could create a fire hazard and/or damage.

SPARK PLUG(S)

Replace spark plug(s) at the beginning of each mowing season or after every 100 hours of operation, whichever occurs first. Spark plug type and gap setting are shown in "PRODUCT SPECIFICATIONS" section of this manual.

CLEANING

- Clean engine, battery, seat, finish, etc. of all foreign matter.
- Keep finished surfaces and wheels free of all gasoline, oil, etc.
- Protect painted surfaces with automotive type wax.

We do not recommend using a garden hose or pressure washer to clean your riding mower unless the engine and transmission are covered to keep water out. Water in engine or transmission will shorten the useful life of your riding mower. Use compressed air or a leaf blower to remove grass, leaves and trash from riding mower and mower.

SERVICE AND ADJUSTMENTS



WARNING: TO AVOID SERIOUS INJURY, BEFORE PERFORMING ANY SERVICE OR ADJUSTMENTS:

1. Depress clutch/brake pedal fully and set parking brake.
2. Place motion control lever in neutral (N) position.
3. Place deck clutch in "DISENGAGED" position.
4. Turn ignition key to "STOP" and remove key.
5. Make sure the blade and all moving parts have completely stopped.
6. Disconnect spark plug wire from spark plug and place wire where it cannot come in contact with plug.

RIDING MOWER

TO REMOVE MOWER

1. Place deck clutch in "DISENGAGED" position.
2. Move mower height adjustment lift lever forward to lower mower to its lowest position.
3. Remove mandrel cover.
4. Remove pins holding left and right front mower suspension arms in place.
5. Remove bolt holding deck front to rear leveling rod in place.

6. Remove pin holding deck lift link arm in place.
7. Remove bolt holding deck side to side leveling rod in place.
8. Remove belt from around pulleys.
9. Slide deck out from under side of mower.

TO INSTALL MOWER

Install in reverse order following instructions in "TO REMOVE MOWER" section.

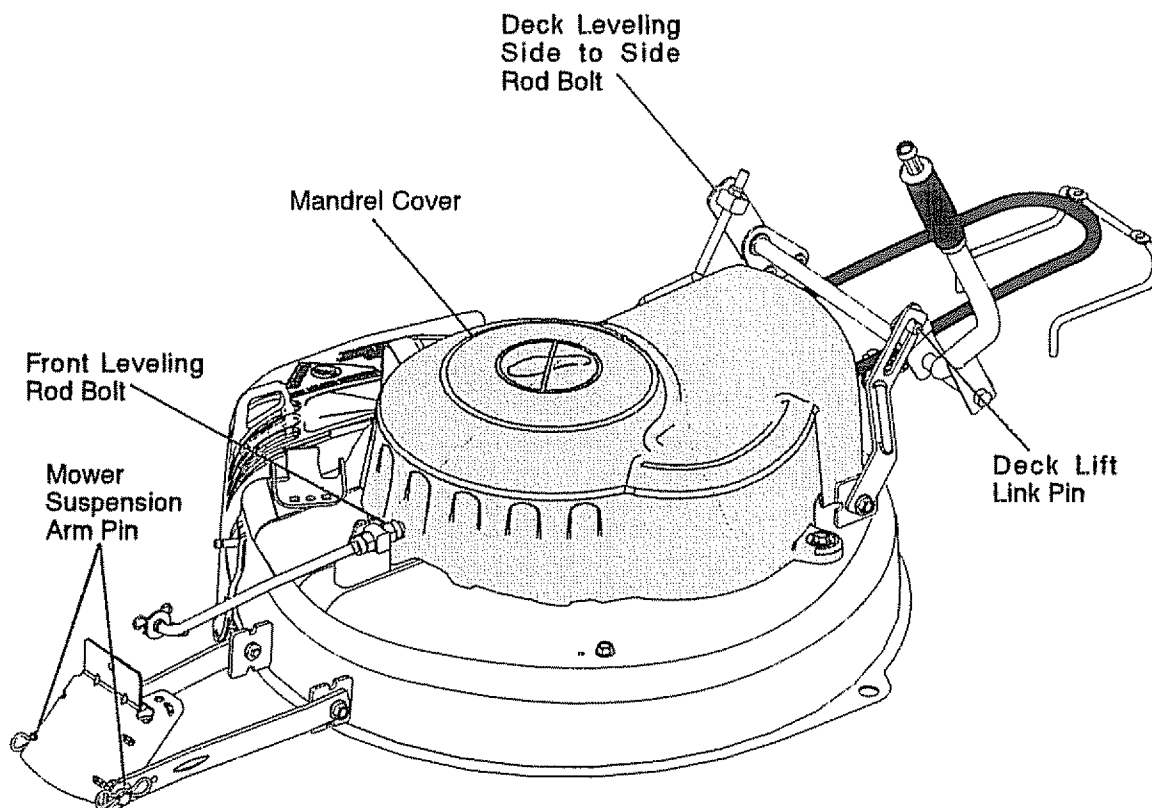

TO LEVEL MOWER HOUSING

Adjust the mower while riding mower is parked on level ground or driveway. Make sure tires are properly inflated (See side of tire for proper PSI). If tires are over or underinflated, you will not properly adjust your mower.

SIDE-TO-SIDE ADJUSTMENT

- Raise mower to its highest position.
- Measure distance "A" from bottom edge of mower to ground level at front corners of mower.
- To raise the right side of the mower, tighten lift link adjustment nut.
- To lower the right side of the mower, loosen lift link adjustment nut.

NOTE: Each full turn of adjustment nut will change mower height about 3/16".

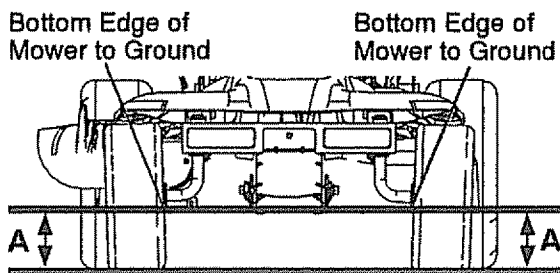

- Recheck measurements after adjusting.

FRONT-TO-BACK ADJUSTMENT

IMPORTANT: Deck must be level side-to-side.

To obtain the best cutting results, the mower housing should be adjusted so that the front is approximately 1/8" to 1/2" lower than the rear when the mower is in its highest position. Check adjustment on right side of riding mower. Measure distance "F" directly in front and behind the mandrel at bottom edge of mower housing as shown.

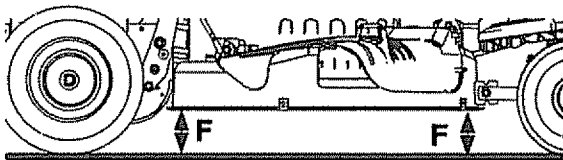

- To lower front of mower housing turn nuts "G" and "H" clockwise.
- When distance "F" is 1/8" to 1/2" lower at front than rear, tighten nut "H" against trunnion on front link.
- To raise front of mower housing turn nuts "G" and "H" counter clockwise.
- When distance "F" is 1/8" to 1/2" lower at front than rear, tighten nut "H" against trunnion on front link.

NOTE: Each full turn of "G" will change "F" by approximately about 3/8".

- Recheck side-to-side adjustment.

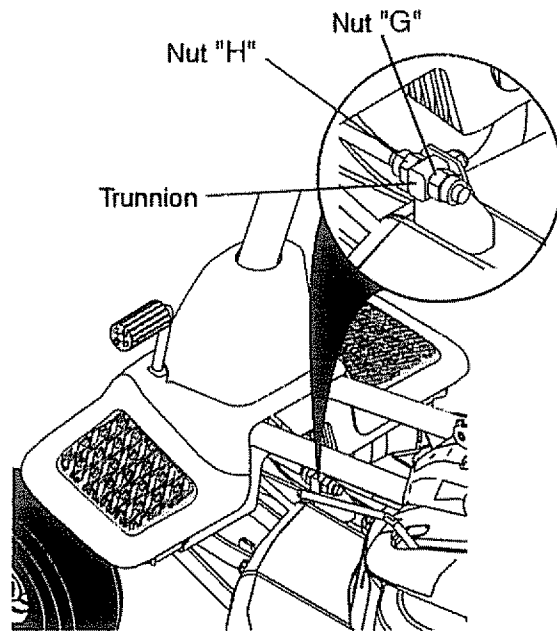

TO REPLACE MOWER BLADE DRIVE BELT

MOWER DRIVE BELT REMOVAL

1. Park riding mower on a level surface.
2. Set parking brake.
3. Lower mower to its lowest position.
4. Remove mandrel cover from mower deck.
5. Remove rear engine plate from unit.
6. Remove rear belt keeper from unit.
7. Carefully roll belt over the top of the mower blade mandrel.
8. Remove belt from idler pulleys.

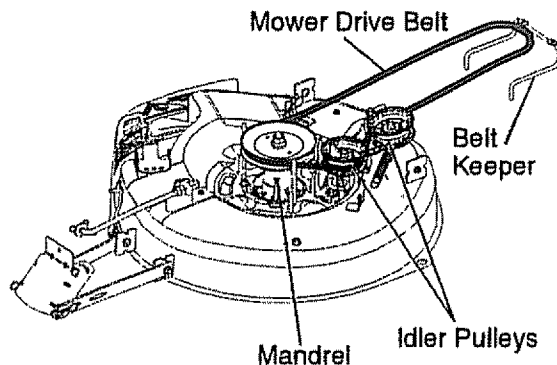

9. Check idler pulleys to see that they rotate freely.
10. Remove belt from rear drive pulley.

MOWER DRIVE BELT INSTALLATION

Install in reverse order following instructions in "MOWER DRIVE BELT REMOVAL" section.

TO ADJUST BRAKE

Your riding mower is equipped with an adjustable brake system which is mounted on the right side of the transaxle. If riding mower requires more than (4) feet stopping distance in highest gear on a level dry concrete or paved surface, then brake must be adjusted.

1. Park riding mower on a level surface.
2. Release brake/parking pedal.
3. Measure distance between rotor and brake pad if distance between rotor and brake pad is more than .02" gap brake needs to be adjusted.
4. Tighten caliper nut until .02" gap is reached.

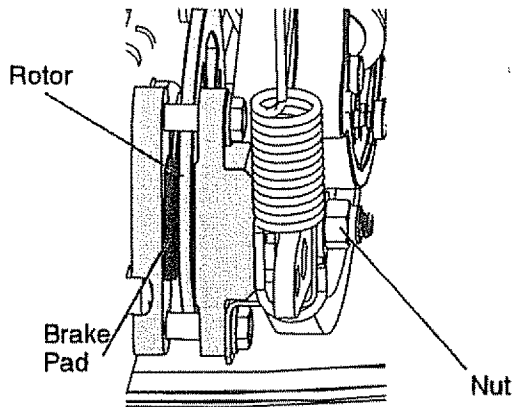

NOTE: Feeler gauge may be necessary to get correct measurement.

TO ADJUST STEERING WHEEL ALIGNMENT

If steering wheel crossbars are not horizontal (left to right) when wheels are positioned straight forward, move steering wheel and reassemble per instructions in the "INSTALL STEERING COLUMN" section of this manual.

TO REMOVE WHEEL FOR REPAIRS

FRONT WHEEL

1. Block up front axle securely.
2. Remove dust cover, retaining ring, and washer to allow wheel removal.
3. Repair tire and reassemble.
4. Replace washer and retaining ring securely in axle groove.

REAR WHEEL

1. Block up Rear axle securely.
2. Remove dust cover, retaining ring, washer, and square key while pulling tire off.
3. Repair tire and reassemble.
4. Replace square key while putting tire back on, then replace washer and retaining ring securely in axle groove, when pushing tire back onto shaft reach under and pull chain sprocket toward you to ease tire replacement.

NOTE: To seal tire punctures and prevent flat tires due to slow leaks, purchase and use tire sealant. Tire sealant also prevents tire dry rot and corrosion.

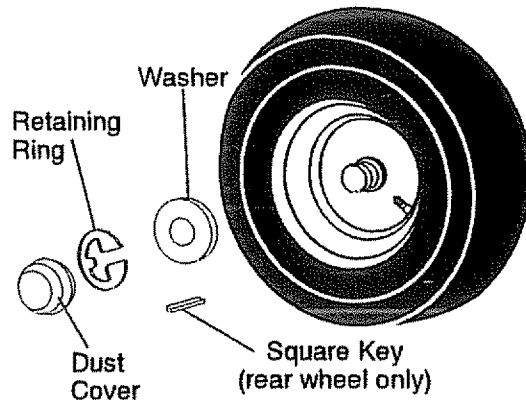

TO START ENGINE WITH A WEAK BATTERY

CAUTION: Lead-acid batteries generate explosive gases. Keep sparks, flame and smoking materials away from batteries. Always wear eye protection when around batteries.

If your battery is too weak to start the engine, it should be recharged. (See "BATTERY" in the Maintenance section of this manual).

NOTE: This unit is equipped with an engine recoil starting system that can be used if the battery is too weak to start. See "RECOIL STARTING SYSTEM" in operation section of this manual.

REPLACING BATTERY

WARNING: Do not short battery terminals by allowing a wrench or any other object to contact both terminals at the same time. Before connecting battery, remove metal bracelets, wristwatch bands, rings, etc. Positive terminal must be connected first to prevent sparking from accidental grounding.

1. Lift seat for bolt access.
2. Disconnect BLACK battery cable then RED battery cable.
3. Remove battery bracket bolt.
4. Install new battery with terminals facing to the right, and away from seat as shown.
5. Reinstall battery bracket and bolt.
6. First connect RED battery cable to positive (+) battery terminal.
7. Connect BLACK grounding cable to negative (-) battery terminal.

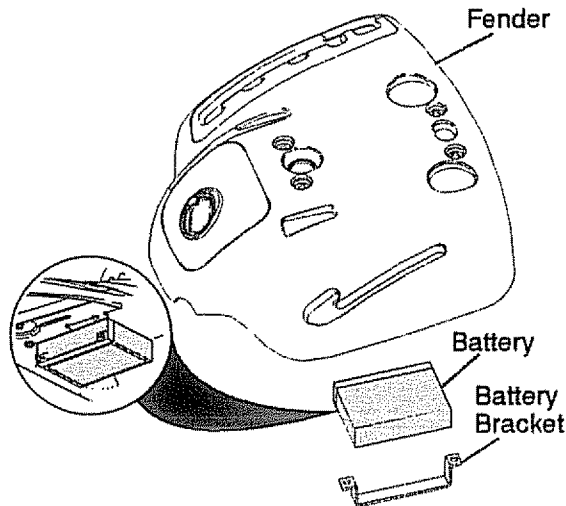

ENGINE

Your engine speed has been factory set. Do not attempt to increase engine speed or it may result in personal injury. If you believe that the engine is running too fast or too slow, take your riding mower to a qualified service center for repair and/or adjustment.

Your carburetor is not adjustable. If your engine does not operate properly due to suspected carburetor problems, take your riding mower to a qualified service center for repair and/or adjustment.

IMPORTANT: Never tamper with the engine governor, which is factory set for proper engine speed. Overspeeding the engine above the factory high speed setting can be dangerous. If you think the engine-governed high speed needs adjusting, contact a qualified service center, which has proper equipment and experience to make any necessary adjustments.

INTERLOCKS AND RELAYS

Loose or damaged wiring may cause your riding mower to run poorly, stop running, or prevent it from starting.

- Check wiring. Make sure all wiring and connectors are secure.

TO REPLACE FUSE

Replace with 4 amp. or 5 amp. automotive type plug-in fuse. The fuse holder is located under the fender.

STORAGE

Immediately prepare your riding mower for storage at the end of the season or if the riding mower will not be used for 30 days or more.

⚠ WARNING: Never store the riding mower with gasoline in the tank inside a building where fumes may reach an open flame or spark. Allow the engine to cool before storing in any enclosure.

MOWER

Remove deck from mower for winter storage. When mower is to be stored for a period of time, clean it thoroughly, remove all dirt, grease, leaves, etc. Store in a clean, dry area.

1. Clean entire riding mower (See "CLEANING" in the Maintenance section of this manual).
2. Inspect and replace belt, if necessary (See belt replacement instructions in the Service and Adjustments section of this manual).
3. Lubricate as shown in the Maintenance section of this manual.
4. Be sure that all nuts, bolts and screws are securely fastened. Inspect moving parts for damage, breakage and wear. Replace if necessary.
5. Touch up all rusted or chipped paint surfaces; sand lightly before painting.

BATTERY

- Fully charge the battery for storage.
- If battery is removed from riding mower for storage, do not store battery directly on concrete or damp surfaces.

ENGINE

FUEL SYSTEM

IMPORTANT: It is important to prevent gum deposits from forming in essential fuel system parts such as carburetor, fuel hose, or tank during storage. Also, alcohol blended fuels (called gasohol or using ethanol or methanol) can attract moisture which leads to separation and formation of acids during storage. Acidic gas can damage the fuel system of an engine while in storage.

- Empty the fuel tank by starting the engine and letting it run until the fuel lines and carburetor are empty.
- Never use engine or carburetor cleaner products in the fuel tank or permanent damage may occur.
- Use fresh fuel next season.

NOTE: Fuel stabilizer is an acceptable alternative in minimizing the formation of fuel gum deposits during storage. Add stabilizer to gasoline in fuel tank or storage container. Always follow the mix ratio found on stabilizer container. Run engine at least 10 minutes after adding stabilizer to allow the stabilizer to reach the carburetor. Do not empty the gas tank and carburetor if using fuel stabilizer.

ENGINE OIL

Drain oil (with engine warm) and replace with clean engine oil. (See "ENGINE" in the Maintenance section of this manual).

CYLINDER(S)

1. Remove spark plug(s).
2. Pour one ounce of oil through spark plug hole(s) into cylinder(s).
3. Turn ignition key to "START" position for a few seconds to distribute oil.
4. Replace with new spark plug(s).

OTHER

- Do not store gasoline from one season to another.
- Replace your gasoline can if your can starts to rust. Rust and/or dirt in your gasoline will cause problems.
- If possible, store your riding mower indoors and cover it to give protection from dust and dirt.
- Cover your riding mower with a suitable protective cover that does not retain moisture. Do not use plastic. Plastic cannot breathe which allows condensation to form and will cause your riding mower to rust.

IMPORTANT: Never cover riding mower while engine and exhaust areas are still warm.

TROUBLESHOOTING CHART:

| PROBLEM | | CAUSE | | CORRECTION |
|---|----|--|----|--|
| Will not start | 1 | Out of fuel. | 1 | Fill fuel tank. |
| | 2 | Bad spark plug. | 2 | Replace spark plug. |
| | 3 | Dirty air filter. | 3 | Clean/replace air filter. |
| | 4 | Water in fuel. | 4 | Empty fuel tank and carburetor, refill tank with fresh gasoline and replace fuel filter. |
| | 5 | Loose or damaged wiring. | 5 | Check all wiring. |
| | 6 | Engine valves out of adjustment. | 6 | Contact a qualified service center. |
| Hard to start | 1 | Dirty air filter. | 1 | Clean/replace air filter. |
| | 2 | Bad spark plug. | 2 | Replace spark plug. |
| | 3 | Weak or dead battery. | 3 | Recharge or replace battery. |
| | 4 | Stale or dirty fuel. | 4 | Empty fuel tank and refill tank with fresh, clean gasoline. |
| | 5 | Loose or damaged wiring. | 5 | Check all wiring. |
| | 6 | Engine valves out of adjustment. | 6 | Contact a qualified service center. |
| Engine will not turn over | 1 | Clutch/brake pedal not depressed. | 1 | Depress clutch/brake pedal. |
| | 2 | Deck clutch is engaged. | 2 | Disengage deck clutch. |
| | 3 | Weak or dead battery. | 3 | Recharge or replace battery. |
| | 4 | Blown fuse. | 4 | Replace fuse. |
| | 5 | Corroded battery terminals. | 5 | Clean battery terminals. |
| | 6 | Loose or damaged wiring. | 6 | Check all wiring. |
| | 7 | Faulty ignition switch. | 7 | Check/replace ignition switch. |
| | 8 | Faulty solenoid or starter. | 8 | Check/replace solenoid or starter. |
| | 9 | Faulty operator presence switch(es). | 9 | Contact a qualified service center. |
| Engine clicks but will not start | 1 | Weak or dead battery. | 1 | Recharge or replace battery. |
| | 2 | Corroded battery terminals. | 2 | Clean battery terminals. |
| | 3 | Loose or damaged wiring. | 3 | Check all wiring. |
| | 4 | Faulty solenoid or starter. | 4 | Check/replace solenoid or starter. |
| Loss of power | 1 | Cutting too much grass/too fast. | 1 | Raise cutting height/reduce speed. |
| | 2 | Build-up of grass, leaves and trash under mower. | 2 | Clean underside of mower housing. |
| | 3 | Dirty air filter. | 3 | Clean/replace air filter. |
| | 4 | Low oil level/dirty oil. | 4 | Check oil level/change oil. |
| | 5 | Faulty spark plug. | 5 | Clean & regap or change spark plug. |
| | 6 | Stale or dirty fuel. | 6 | Empty fuel tank and refill tank with fresh, clean gasoline. |
| | 7 | Water in fuel. | 7 | Empty fuel tank and carburetor, refill tank with fresh gasoline. |
| | 8 | Spark plug wire loose. | 8 | Connect & tighten spark plug wire. |
| | 9 | Dirty engine air screen/fins. | 9 | Clean engine air screen/fins. |
| | 10 | Dirty/clogged muffler. | 10 | Clean/replace muffler. |
| | 11 | Loose or damaged wiring. | 11 | Check all wiring. |
| | 12 | Engine valves out of adjustment. | 12 | Contact a qualified service center. |
| Excessive vibration | 1 | Worn, bent or loose blade. | 1 | Replace blade. Tighten blade bolt. |
| | 2 | Bent blade mandrel. | 2 | Contact a qualified service center. |
| | 3 | Loose/damaged part(s). | 3 | Tighten loose part(s). Replace damaged parts. |

TROUBLESHOOTING CHART:

| PROBLEM | | CAUSE | | CORRECTION |
|---|---|---|---|---|
| Engine continues to run when operator leaves seat with attachment clutch engaged | 1 | Faulty operator-safety presence control system. | 1 | Check wiring, switches and connections. If not corrected, contact a qualified service center. |
| Poor cut - uneven cutting | 1 2 3 4 5 | Worn, bent or loose blade. Mower deck not level. Buildup of grass, leaves, and trash under mower. Bent blade mandrel. Clogged mower deck vent from build-up of grass, leaves, and trash around mandrel. | 1 2 3 4 5 | Replace blade. Tighten blade bolt. Level mower deck. Clean underside of mower housing. Contact a qualified service center. Clean around mandrels to open vent holes. |
| Mower blade will not rotate | 1 2 3 4 | Obstruction in clutch mechanism. Worn/damaged mower drive belt. Frozen idler pulley. Frozen blade mandrel. | 1 2 3 4 | Remove obstruction. Replace mower drive belt. Replace idler pulley. Contact a qualified service center. |
| Poor grass discharge | 1 2 3 4 5 6 7 8 9 10 | Travel speed too fast. Wet grass. Mower deck not level. Low/uneven tire air pressure. Worn, bent or loose blade. Buildup of grass, leaves and trash under mower. Mower drive belt worn. Blade improperly installed. Improper blade used. Clogged mower deck vent holes from buildup of grass, leaves, and trash around mandrels. | 1 2 3 4 5 6 7 8 9 10 | Shift to slower speed. Allow grass to dry before mowing. Level mower deck. Check tires for proper PSI. Replace/sharpen blade. Tighten blade bolt. Clean underside of mower housing. Replace mower drive belt. Reinstall blade sharp edge down. Replace with blade listed in this manual. Clean around mandrels to open vent holes. |
| Battery will not charge | 1 2 3 | Bad battery cell(s). Poor cable connections. Faulty alternator. | 1 2 3 | Replace battery. Check/clean all connections. Replace alternator. |
| Loss of drive | 1 2 3 | Freewheel control in "DISENGAGED" position. Air trapped in transmission during shipment or servicing. Axle key missing. | 1 2 3 | Place freewheel control in "ENGAGED" position. Purge transmission. Install axle key at rear wheel. See "TO REMOVE WHEEL" in the Service and Adjustments section. |
| Engine dies when tractor is shifted into reverse | 1 | Reverse operation system (ROS) is not "ON" while mower or other attachment is engaged. | 1 | Turn ignition key to ROS "ON" position. See Operation section. |

RIDING MOWER - -CATALOG NO. WE261

SCHEMATIC

SC3121

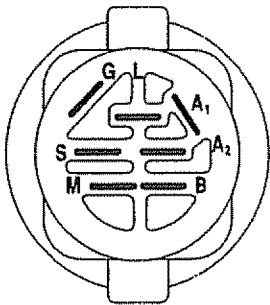
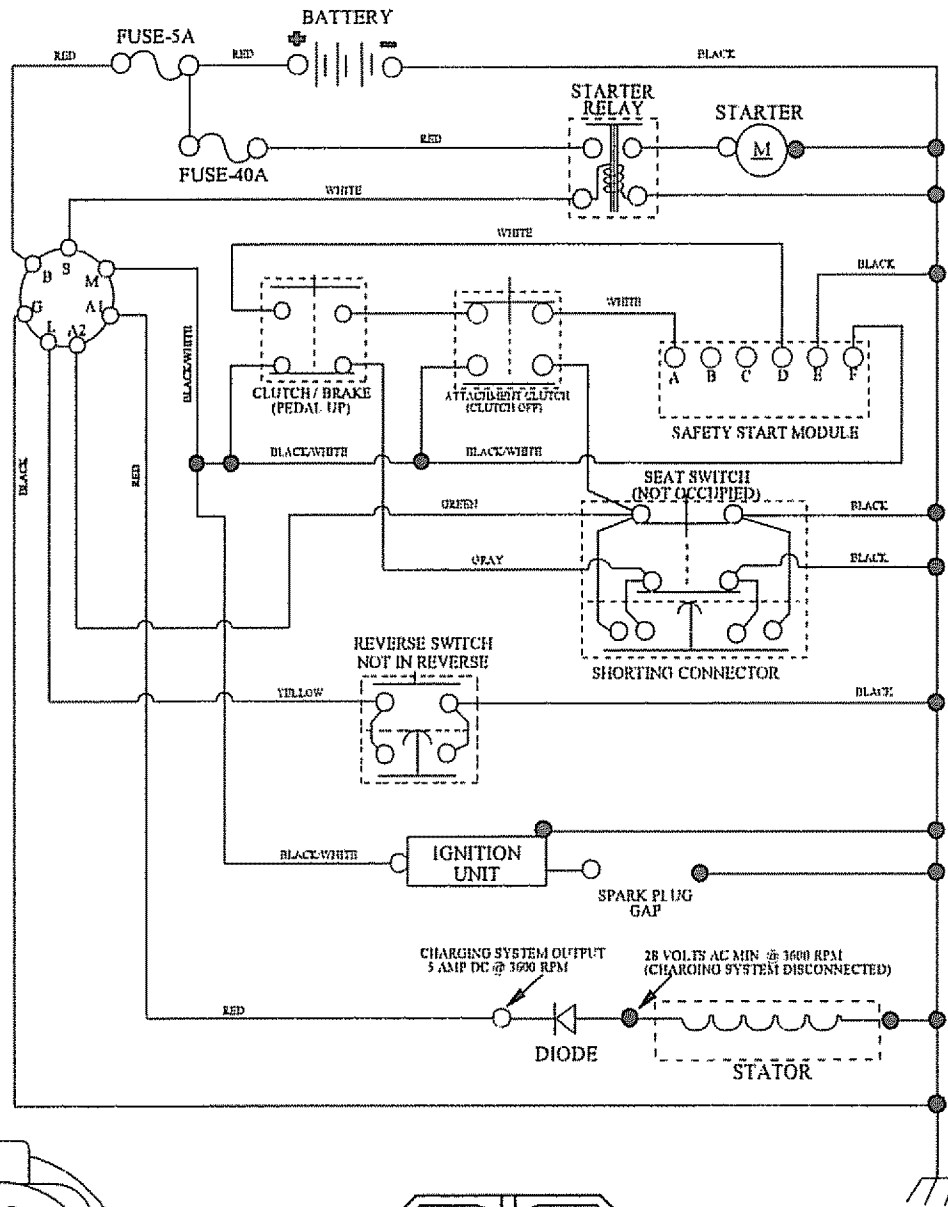

IGNITION SWITCH

| POSITION | CIRCUIT "MAKE" |
|--------------|----------------|
| OFF | M+G+A1 |
| RUN/OVERRIDE | B+A1 |
| RUN | B+A1 L+A2 |
| START | B + S + A1 |

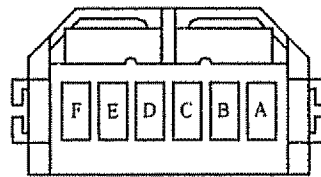

SAFETY START MODULE
VIEWED FROM MATING SIDE

WIRING INSULATED CLIPS
NOTE: IF WIRING INSULATED CLIPS WERE REMOVED FOR SERVICING OF UNIT, THEY SHOULD BE RE-INSTALLED TO PROPERLY SECURE YOUR WIRING

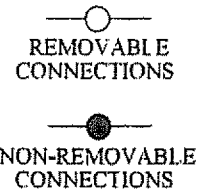

RIDING MOWER - -CATALOG NO. WE261

ELECTRICAL

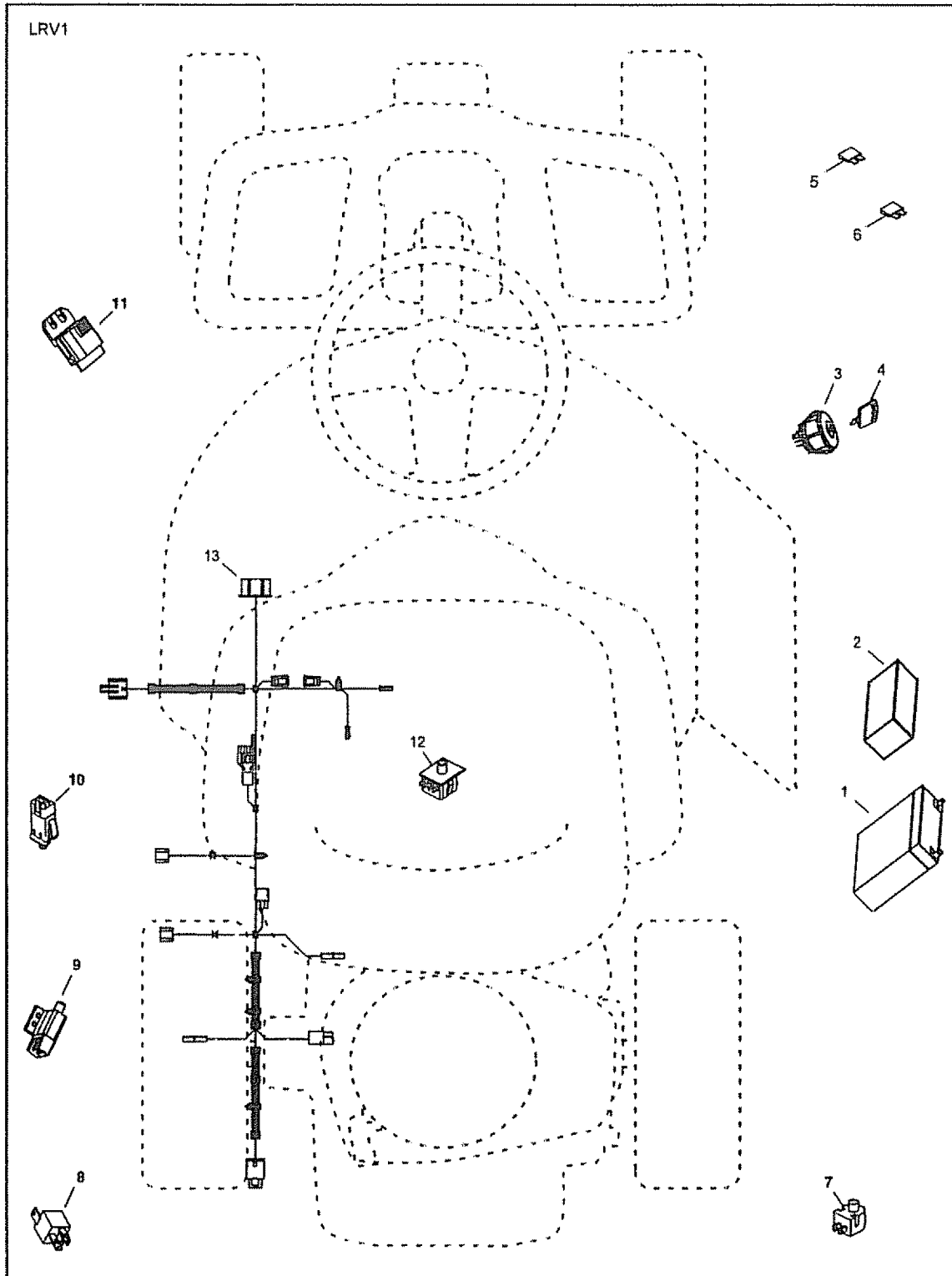

ELECTRICAL**RIDING MOWER - -CATALOG NO. WE261**

| KEY NO. | PART NO. | DESCRIPTION |
|--------------------|---------------------|-------------------------------|
| 1 | 423264 | BATTERY, 12V, 8AH |
| 2 | 425416 | FOAM, POLYURETHANE |
| 3 | 193350 | SWITCH, IGN, DLTA, P-IN, ROS |
| 4 | 411934 | KEY, MOLDED |
| 5 | 433330 | FUSE, 5A |
| 6 | 425937 | FUSE, 40A |
| 7 | 160784 | SWITCH, PLUNGER, NO, OLIVE |
| 8 | 431542 | RELAY, 40A |
| 9 | 109553X | SWITCH, INTLK,CL, MWR, GRY |
| 10 | 176138 | SWITCH, INTERLOCK, NONC,GRAY |
| 11 | 431846 | MODULE, STARTING, RECOIL, LRV |
| 12 | 192749 | SWITCH, SEAT, DP, ROS |
| 13 | 428477 | HARNESS, IGN, ELECTSTART, LRV |

NOTE: All component dimensions given in U.S. inches
1 inch = 25.4 mm

RIDING MOWER - -CATALOG NO. WE261

CHASSIS

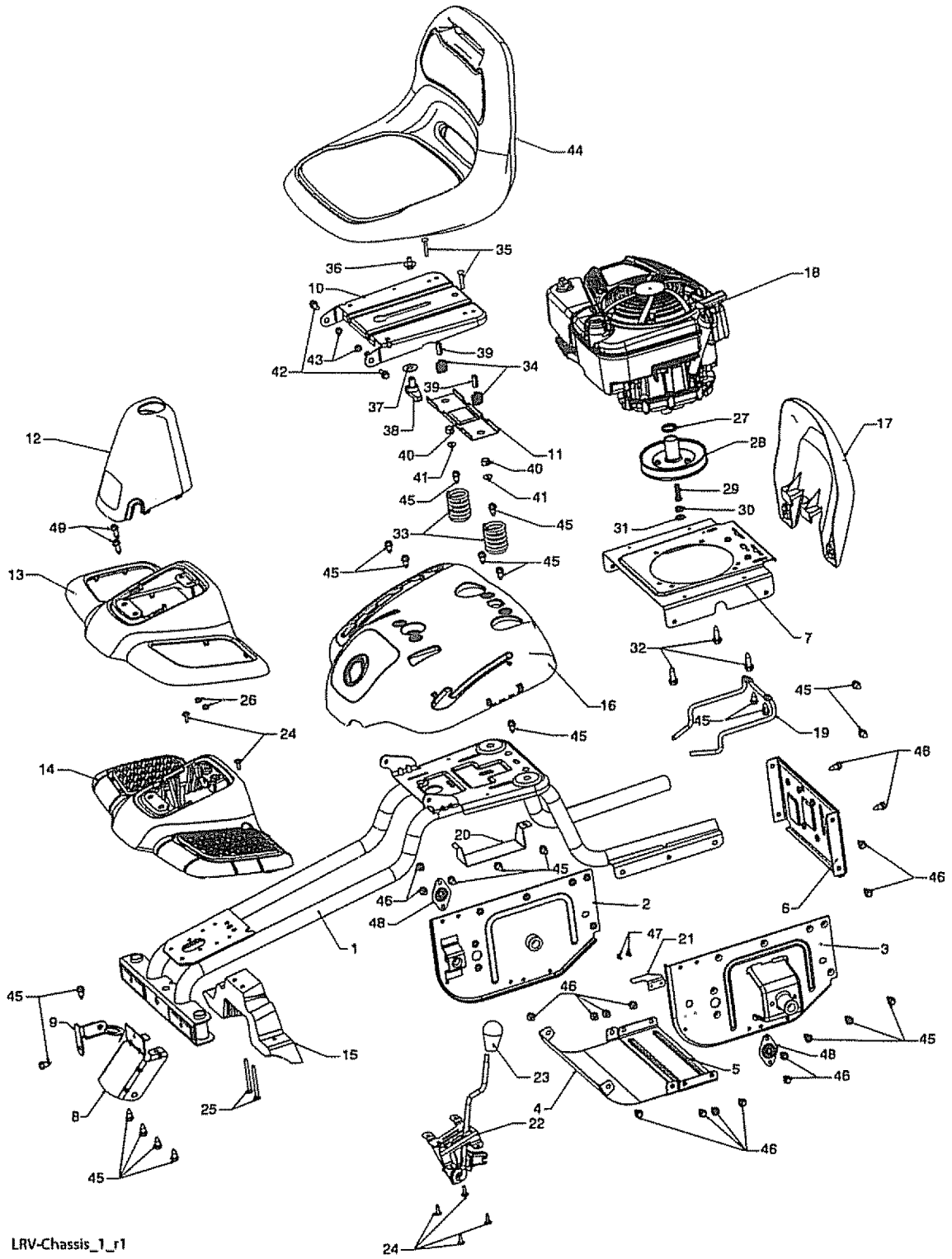

LRV-Chassis_1_r1

RIDING MOWER - -CATALOG NO. WE261

CHASSIS

| KEY NO. | PART NO. | DESCRIPTION |
|---------|------------|------------------------------|
| 1 | 428048 | WELDMENT, CHASSIS |
| 2 | 428247 | SUPPORT, AXEL LH |
| 3 | 428244 | SUPPORT, AXEL RH |
| 4 | 428346 | SHIELD, TRANSAXLE FRONT |
| 5 | 428110 | BRACE, AXLE CROSS |
| 6 | 428109 | COVER, FRICTION DRIVE |
| 7 | 428040 | PLATE, ENGINE |
| 8 | 428576 | BRACKET, CHASSIS FRONT |
| 9 | 428856 | BRACKET, STEERING SUPPORT |
| 10 | 195530 | PAN, SEAT |
| 11 | 174648X431 | BRACKET, SWITCH MOUNTING |
| 12 | 428248 | BOOT, DUST |
| 13 | 428251X665 | COVER, FOOT REST |
| 14 | 428250 | STRUCTURE, FOOT REST |
| 15 | 428249 | SUPPORT, FOOT REST |
| 16 | 428241X665 | FENDER, CONTROL |
| 17 | 428348 | GUARD, ENGINE |
| 18 | 428047 | ENGINE (NON-CALIFORNIA) |
| -- | 432389 | ENGINE (CALIFORNIA) |
| 19 | 428986 | KEEPER, BELT |
| 20 | 428046 | BRACKET, BATTERY |
| 21 | 429815 | LEVER, SWITCH |
| 22 | 428826 | DECK CLUTCH ASM |
| 23 | 149846 | KNOB |
| 24 | 416358 | SCREW, NO. 10 |
| 25 | 72140424 | BOLT, CARRIAGE 1/4-20 X 3 |
| 26 | 73510400 | NUT, 1/4-20 |
| 27 | 430087 | SPACER, ENGINE |
| 28 | 428301 | DISC, FRICTION ASM |
| 29 | 430817 | BOLT, SCKT HD 3/8-24 X 1 .25 |
| 30 | 430470 | BEARING |
| 31 | 430469 | SPACER, NEUTRAL |
| 32 | 150406 | BOLT, 3/8-16 X .280 |
| 33 | 124181X | SPRING, SEAT |
| 34 | 121250X | SPRING |
| 35 | 72050412 | BOLT, 1/4-20 X 1 1/2 |
| 36 | 127018X | BOLT, SHOULDER |
| 37 | 19171912 | WASHER, 17/32 X 1 3/16 |
| 38 | 166369 | KNOB, SEAT |
| 39 | 134300 | SPACER |
| 40 | 121248X | BUSHING, NYLON SNAP |
| 41 | 123976X | NUT, LOCK |
| 42 | 171852 | BOLT, 5/16-18 SHOULDER |
| 43 | 73800500 | NUT, 5/16-18 |
| 44 | 428243 | SEAT |
| 45 | 17000512 | BOLT, 5/16-18 X 3/4 |
| 46 | 17490508 | BOLT, 5/16-18 X 1/2 |
| 47 | 86777 | SCREW |
| 48 | 408981 | BEARING FLANGE BALL |
| 49 | 17060516 | SCREW 5/16-18 X1 |

NOTE: All component dimensions given in U.S. Inches
1 Inch = 25.4 mm

DRIVE

RIDING MOWER - -CATALOG NO. WE261

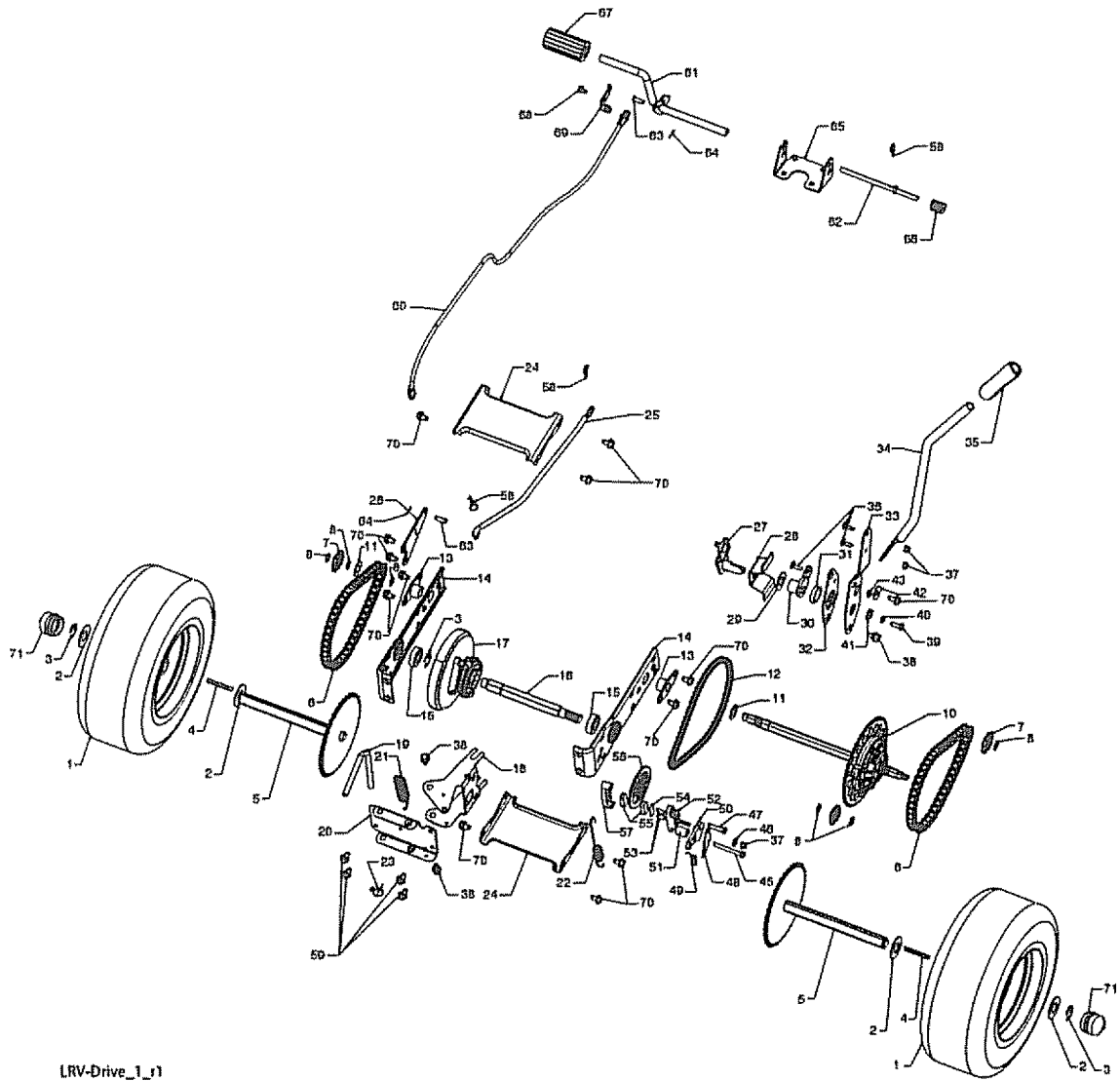

LRV-Drive_1_1

RIDING MOWER - -CATALOG NO. WE261

DRIVE

| KEY PART NO. NO. | DESCRIPTION | KEY PART NO. NO. | DESCRIPTION |
|---------------------|--|---------------------|----------------------------------|
| 1 | 428268X613 WHEEL ASM (REAR) | 40 | 10040400 WASHER, LOCK |
| 2 | 121748X WASHER, 16 GA. | 41 | 19091210 WASHER FLAT |
| 3 | 12000001 E-CLIP | 42 | 166002 WASHER, SERRATED |
| 4 | 123583X KEY, SQUARE | 43 | 73680400 NUT, CROWN LOCK 114-20 |
| 5 | 427939 WELDMNT. DRIVE AXLE | 45 | 17490436 SCREW 1/4-20 X 2 114 |
| 6 | 428069 CHAIN DRIVE | 46 | 19091016 WASHER |
| 7 | 427873 SPROCKET, 9 TOOTH SPLINED | 47 | 17490420 SCREW, 1/4-20 X 1 1/2 |
| 8 | 12100009 RING, SNAP | 48 | 430249 PLATE BRAKE ANTI - ROTATE |
| 10 | 428876 DIFFERENTIAL ASM | 49 | 430245 SPRING, BRAKE RETURN |
| 11 | 1370H WASHER, THRUST | 50 | 428021 ARM, BRAKE |
| 12 | 430645 CHAIN, PRIMARY DRIVE | 51 | 430247 SPACER RETURN |
| 13 | 430845 BUSHING | 52 | 428078 CALIPER, BRAKE ASM |
| 14 | 427946 BRACKET, CARRIER | 53 | 77010810 PIN, DOWEL 1/4 |
| 15 | 9159R BEARING ASM | 54 | 428019 PLATE, BRAKE PAD |
| 16 | 427926 SHAFT INPUT | 55 | 428017 PUCK BRAKE |
| 17 | 428106 WHEEL, FRICTION ASM | 56 | 428014 ROTOR, BRAKE |
| 18 | 424759 ARM, SHIFT | 57 | 428016 CAP, BRAKE CALIPER |
| 19 | 430870 ROD, BYPASS | 58 | 4497H PIN, RETAINER |
| 20 | 427997 BRACE CARRIER REAR | 59 | 17490508 BOLT, 5/16-16 X 112 |
| 21 | 428077 SPRING, CARRIER | 60 | 428460 CABLE, BRAKE |
| 22 | 428076 SPRING, BRAKE | 61 | 427945 WELDMNT, PEDAL |
| 23 | 431374 SPRING, BYPASS | 62 | 429678 ROD, PARKING BRAKE |
| 24 | 427995 BRACE CARRIER BOX | 63 | 77100812 PIN, .25 X .75 CLEVIS |
| 25 | 429303 LINK, SHIFT | 64 | 76020208 PIN, 1/16 DIA. COTTER |
| 26 | 429816 ARM, CLUTCH | 65 | 429325 BRACKET, BRAKE SUPPORT |
| 27 | 429053 WELDMNT SHIFT LEVER | 66 | 429694 COVER PEDAL |
| 28 | 428302 SUPPORT, SHIFT LEVER | 67 | 429693 COVER, BRAKE PEDAL |
| 29 | 174840 WASHER, NYLON | 68 | 17490408 SCREW, 1/4-20 X 1/2 |
| 30 | 183900 HUB SHIFT LEVER | 69 | 428070 BRAKE CABLE MOUNT |
| 31 | 429055 SPACER, NYLON | 70 | 17000512 BOLT, 5/16-18 X 3/4 |
| 32 | 428464 MNTG BRKT. SHIFT ARM | 71 | 104757X613 CAP HUB AXLE |
| 33 | 428461 BRACKET, SHIFTER FLEX | | |
| 34 | 428462 TUBE SHIFT ARM | | |
| 35 | 196492 GRIP, HANDLE | | |
| 36 | 72110406 BOLT, CARRIAGE - 114-20 X 3/4 | | |
| 37 | 73800400 NUT NYLON LOCK 114-20 | | |
| 38 | 165492 BOLT, SHOULDER | | |
| 39 | 74780412 BOLT, 1/4-20 X 3/4 | | |

NOTE: All component dimensions given in U.S. inches
1 inch = 25.4 mm

STEERING

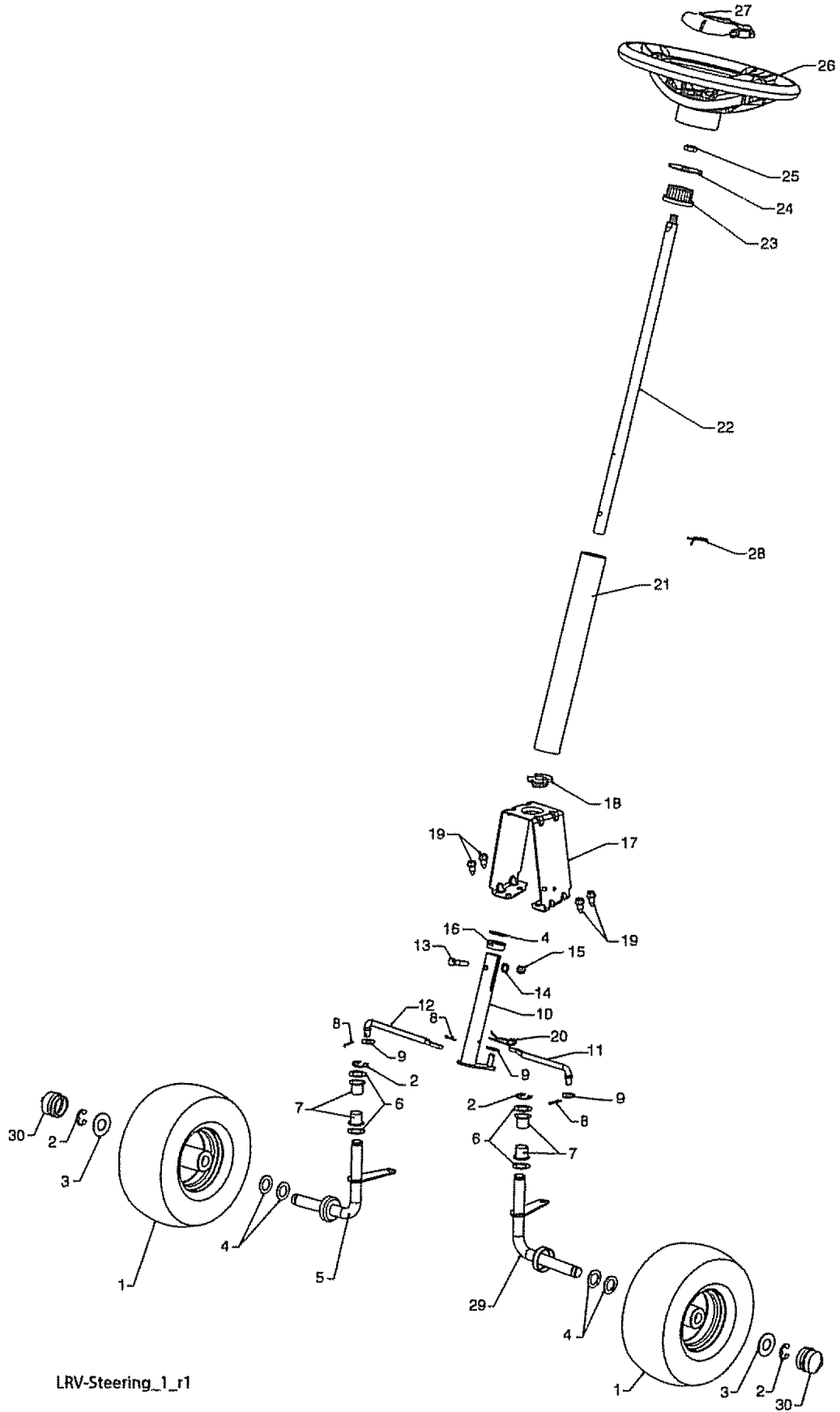

LRV-Steering_1_r1

STEERING**RIDING MOWER - -CATALOG NO. WE261**

| KEY PART NO. | PART NO. | DESCRIPTION |
|-------------------------|---------------------|-----------------------------|
| 1 | 428269X613 | WHEEL ASM (FRONT) |
| 2 | 12000001 | E-CLIP |
| 3 | 188967 | WASHER, HARDENED |
| 4 | 121749X | WASHER, 1/4 X 3/4 |
| 5 | 428034 | SPINDLE, RH |
| 6 | 6266H W | ASHER, HARDENED THRUST |
| 7 | 3366R B | USHING, STEERING COLUMN |
| 8 | 421076 | PIN, 5/64 X 3/4 COTTER |
| 9 | 19131414 | WASHER |
| 10 | 428057 | WELDMENT, LWR STRG SHAFT |
| 11 | 428035 | LINK, STRNG LH |
| 12 | 428036 | LINK, STRNG RH |
| 13 | 74780524 | BOLT, 5/16-18 X 1 1/2 |
| 14 | 19131016 | WASHER |
| 15 | 73800500 | NUT, 5/16-18 |
| 16 | 428044 | BUSHING, STEERING SNAP |
| 17 | 428252 | SUPPORT, UPPER STEERING |
| 18 | 195227 | BUSHING, UPPER STEERING |
| 19 | 17000512 | BOLT, 5/16-18 X 3/4 |
| 20 | 428045 | CLIP, RETAINER SPRING |
| 21 | 428347 | COVER, STEERING COLUMN |
| 22 | 428213 | SHAFT, STEERING |
| 23 | 186737 | ADAPTER, STEERING WHEEL |
| 24 | 19183812 | WASHER, 9/16 X 2 3/8 12 GA. |
| 25 | 73940800 | NUT, JAM LOCK 1/2-20 |
| 26 | 414851X418 | WHEEL, STEERING |
| 27 | 414852X418 | CAP, STEERING WHEEL |
| 28 | 199849 | CLIP, RETAINER SPRING |
| 29 | 428033 | SPINDLE, LH |
| 30 | 104757X613 | CAP, HUB, AXLE |

NOTE: All component dimensions given in U.S. inches
1 inch = 25.4 mm

RIDING MOWER - -CATALOG NO. WE261

MOWER DECK

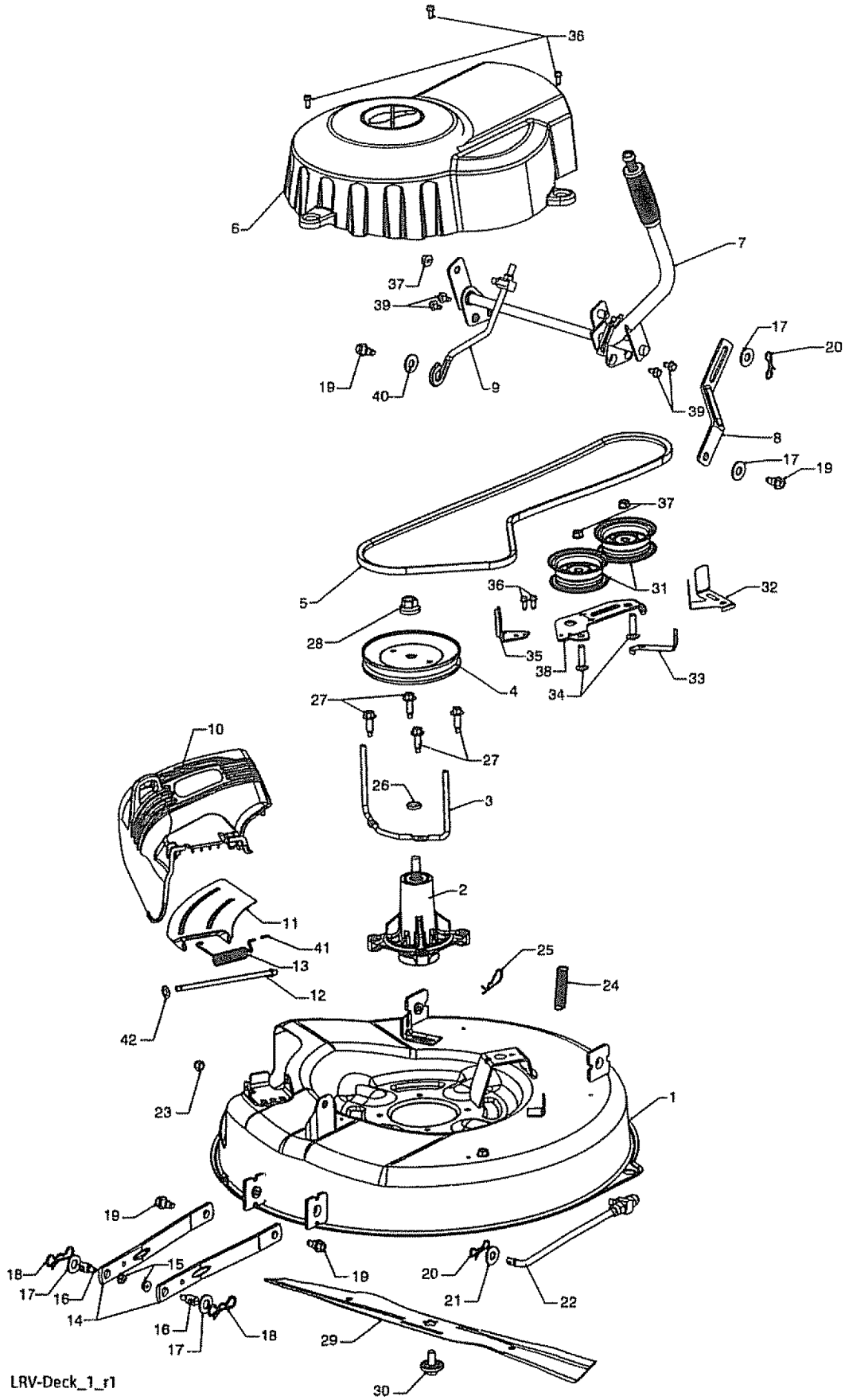

LRV-Deck_1_r1

RIDING MOWER - -CATALOG NO. WE261

MOWER DECK

| KEY PART NO. | PART NO. | DESCRIPTION |
|--------------|----------|------------------------|
| 1 | 428193 | DECK, 26" |
| 2 | 192870 | MANDREL ASM |
| 3 | 432520 | KEEPER, BELT |
| 4 | 432594 | PULLEY, MANDREL |
| 5 | 428578 | BELT |
| 6 | 428242 | COVER, MANDREL |
| 7 | 429395 | LIFT ASM, DECK |
| 8 | 429195 | LINK, DECK LIFT |
| 9 | 429397 | LINK, ADJUSTABLE |
| 10 | 428146 | DEFLECTOR |
| 11 | 428968 | SUPPORT, DEFLECTOR |
| 12 | 131491 | ROD, HINGE |
| 13 | 197026 | SPRING, TORSION |
| 14 | 418863 | ARM, MOWER SUPPORT |
| 15 | 73900500 | NUT, LOCK |
| 16 | 195161 | STUD |
| 17 | 19191912 | WASHER |
| 18 | 194209 | PIN |
| 19 | 196539 | BOLT, SHOULDER |
| 20 | 194208 | PIN |
| 21 | 19171912 | WASHER, 17/32 X 1 3/16 |
| 22 | 429350 | LINK, DECK |
| 23 | 73930600 | NUT, LCK 3/8-16 |
| 24 | 429531 | SPRING, DECK |
| 25 | 4497H | PIN |
| 26 | 187690 | SPACER, MANDREL |
| 27 | 173984 | BOLT, MANDREL |
| 28 | 400234 | NUT, LOCK |
| 29 | 428500 | BLADE |
| 30 | 193003 | BOLT, BLADE |
| 31 | 193197 | PULLEY, IDLER |
| 32 | 141043 | GUARD, IDLER |
| 33 | 193414 | KEEPER, BELT IDLER |
| 34 | 72110612 | BOLT, 3/8-16 X 1 1/2 |
| 35 | 199470 | ARM, BRAKE |
| 36 | 137729 | SCREW, 1/4-20 X 5/8 |
| 37 | 73900600 | NUT, 3/8-16 FLANGE |
| 38 | 428435 | ARM, IDLER |
| 39 | 17490508 | BOLT, 5/16-18 X 1/2 |
| 40 | 19171616 | WASHER, 16 GA. |
| 41 | 105304X | CAP, SLEEVE |
| 42 | 110452X | NUT, PUSH |

NOTE: All component dimensions given in U.S. inches
1 inch = 25.4 mm

RIDING MOWER - -CATALOG NO. WE261

DECALS

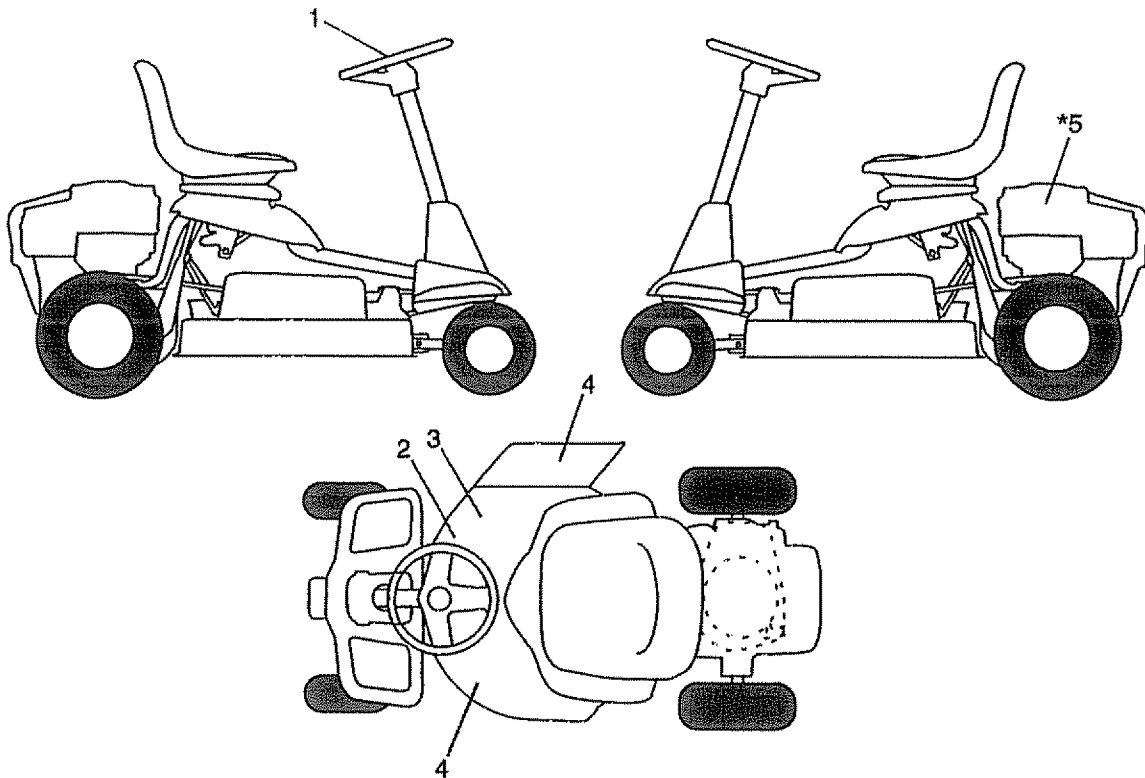

| KEY PART NO. | NO. | DESCRIPTION |
|--------------|--------|----------------------------|
| 1 | 430588 | DECAL, STEERING WHEEL |
| 2 | 433596 | DECAL, V-BELT SCH 30" |
| 3 | 425113 | DECAL, WARN, DEFLECT/CTFGR |
| 4 | 430589 | DECAL, DECK/DEFLECTOR |
| *5 | 424102 | DECAL, SPARK ARRESTOR |
| -- | 432479 | DECAL, BYPASS |
| -- | 433203 | MANUAL OPERATOR ENGLISH |
| -- | 433633 | MANUAL OPERATOR FRENCH |
| -- | 433632 | MANUAL OPERATOR SPANISH |

NOTE: All component dimensions given in U.S. inches
 1 inch = 25.4 mm

SUGGESTED GUIDE FOR SIGHTING SLOPES FOR SAFE OPERATION

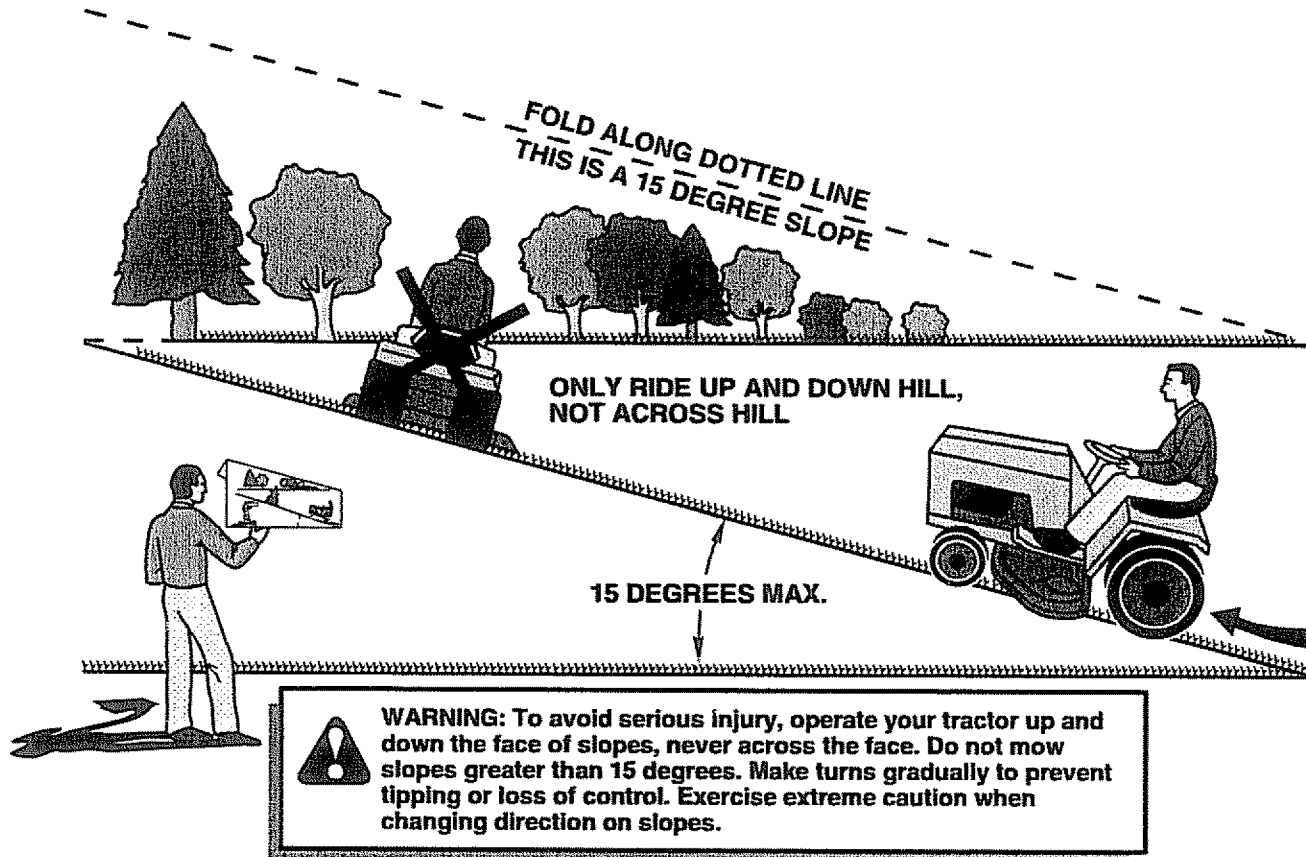

1. Fold this page along dotted line indicated above.
2. Hold page before you so that its left edge is vertically parallel to a tree trunk or other upright structure.
3. Sight across the fold in the direction of hill slope you want to measure.
4. Compare the angle of the fold with the slope of the hill.

12.14.09 CL

WEED EATER[®]
One

Printed in the U.S.A.