

Owner's Manual

8 Gallon Twin-Tank Air Compressor with Detachable Tank

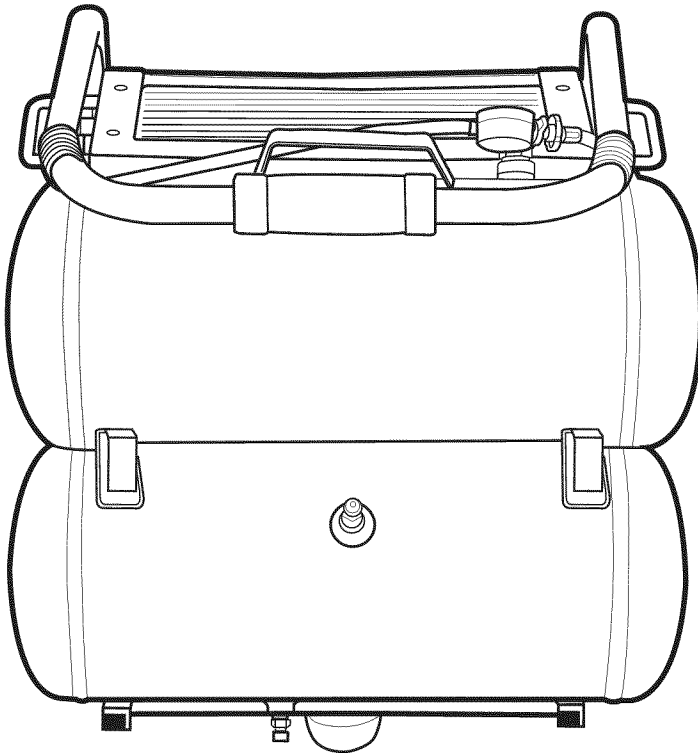

WARNING! To Reduce The Risk Of Injury, User
Must Read And Understand Instruction Manual.

SP-CE358TM

FOR SERVICE CALL: 888-896-6881
PARA SERVICIO LLAME: 888-896-6881

www.steele-products.com

Air Compressor

Table of Contents

| Topic | Page |
|---------------------------------|------|
| Safety Guidelines-Definitions | 4 |
| Hazard Warnings | 5 |
| Air Compressor | 15 |
| Precautions | 15 |
| Basic Air Compressor Components | 16 |
| Assembling the Air Compressor | 16 |
| Compressor Controls | 18 |
| Electrical Power Requirements | 19 |
| Breaking In The Pump | 21 |
| Operating Instructions | 21 |
| Maintenance | 23 |
| Storage | 24 |
| Servicing | 24 |
| Troubleshooting | 25 |
| Glossary Terms | 29 |
| Exploded View | 30 |
| Parts List | 31 |
| Limited Warranty | 32 |

Air Compressor



Warning! Read and understand all safety precautions in this manual before operating. Failure to comply with instructions in this manual could result in personal injury, property damage, and / or voiding of your Warranty. Steele® will not be liable for any damage because of failure to follow these Instructions.

Air Compressor

Prior to installation and usage, thoroughly inspect air compressor for damages.

- Check tank, compressor, compressor motor, and pump for any signs of damage or corrosion.
- Check all screws, bolts, nuts and fasteners, confirm that they are secure.
- Confirm that all fittings, tank petcock, hardware and paint, are free from rust and corrosion.
- Confirm that all compressor settings are correct prior to start up and usage.

Air Tool Inspection

Prior to connecting and using compressor, thoroughly inspect each air tool for damage.

- Check entire tool assembly for any signs of damage or corrosion.
- Check all assembly screws, bolts and nuts and fasteners, confirm that they are secure.
- Confirm that all fittings, bits and hardware are in good condition.
- Confirm that tool settings are correct prior to connection and usage.

Air Compressor

SAFETY GUIDELINES-DEFINITIONS

This manual contains important information that you need to know and understand in order to protect your yourself and to prevent equipment problems. The following symbols help you recognize this information. Please read the manual and pay close attention to these sections.



WARNING! WARNINGS INDICATE A CERTAINTY OR STRONG POSSIBILITY OF PERSONAL INJURY OR DEATH IF INSTRUCTIONS ARE NOT FOLLOWED.



CAUTION: CAUTIONS INDICATE A POSSIBILITY OF EQUIPMENT DAMAGE IF INSTRUCTIONS ARE NOT FOLLOWED.



NOTE: NOTES GIVE HELPFUL INFORMATION.



WARNING! Improper operation or maintenance of this product could result in serious injury and property damage. Read and understand all warnings and operating instructions before using this equipment. When using air tools, basic safety precautions should always be followed to reduce the risk of personal injury.

Save These Import Safety Instructions!

Read and understand all of these safety instructions. Be sure to retain them for future use.

Owner's Manual

Hazard Warnings

Dust



WARNING! Dust from power sanding, sawing, grinding, drilling, and other construction activities contain chemicals known to the state of California to cause cancer, birth defects or other reproductive harm.

These chemicals may include (but are not limited to) the following:

- Lead from lead-based paints
- Crystalline silica from bricks and cement and other masonry products
- Arsenic and chromium from chemically-treated lumber

The risk from these exposures vary, depending on how often you do this type of work. To reduce your exposure to these chemicals: Work in a well ventilated area, and work with approved safety equipment. Always wear MAHA/MIOSH approved, properly fitting face masks or respirators when using such tools. Always follow basic safety precautions when using air tools to reduce the risk of personal injury.

Bursting:

Rust can weaken the tank. Drain the condensed water from the tank after each use to reduce rusting .If a leak is detected in the tank, replace the tank immediately.

Do not weld ,drill or modify the air tank of this compressor .Welding or modifications on the air compressor tank can severely impair tank strength and cause an extremely hazardous condition .Welding or modifying the tank in any manner will void the warranty.

Check the manufacturer's maximum pressure rating for air tools and accessories. Compressor outlet pressure must be regulated so as to never exceed the maximum pressure rating of the tool. Relieve all pressure in the hose before attaching or removing accessories.

Do not tamper with the pressure switch or relief valve for any reason. Doing so voids all warranties. They have been preset at the factory for the maximum pressure of this unit. Personal injury and /or property damage may result if the pressure switch or the relief valve are tampered with.

Do not use plastic or PVC pipe for compressor air. Use only galvanized steel pipe & fittings for compressed air distribution lines.

Owner's Manual

Hazard Warnings (cont'd)

RISK OF EYE OR HEAD INJURY

What could happen:

- Air powered equipment and power tools are capable of propelling materials such as fasteners, metal chips, saw dust, and other debris at high speed, which could result in serious eye injury.
- Compressed air can be hazardous. The air stream can cause injury to soft tissue areas such as eyes, ears, etc. Particles or objects propelled by the stream can cause injury.
- Tool attachments can become loose or break and fly apart propelling particles at the operator and others in the work area.

How to prevent it:

- Always wear ANSI approved Z87.1 safety glasses with glasses with side shields.
- Never leave operating tool unattended. Disconnect air hose when tool is not in use.
- For additional protection, use an approved face shield in addition to safety glasses.
- Make sure that any attachments are securely assembled.
- Never point any nozzle or sprayer toward a person or any part of the body. Equipment can cause serious injury if the spray penetrates the skin.

Owner's Manual

Hazard Warnings (cont'd)

RISK OF FIRE OR EXPLOSION



What could happen:

- Abrasive tools such as sanders and grinders, rotating tools such as drills, and impact tools such as nailers, staples, wrenches, hammers, and reciprocating saws are capable of generating sparks which could result in ignition of flammable materials.
- It is normal for the compressor motor and pressure switch to produce sparks while operating. If sparks come into contact with vapors from gasoline or other solvents, they may ignite, causing a fire or explosion.
- Exceeding the maximum pressure rating of tools or accessories could cause an explosion resulting in serious injury.

How to prevent it:

- Never operate tools near flammable substances such as gasoline, cleaning solvents, etc.
- Work in a clean, well ventilated area free of combustible materials.
- Never use oxygen, carbon dioxide or other bottled gases as power source for air tools.
- Use compressed air regulated to maximum pressure at or below the rated pressure of any attachments.
- Never connect to an air source that is capable of exceeding 90 psi .
- Always verify prior to using the tool that the air source has been adjusted to the rated air pressure range.
- Never spray flammable liquids in a confined area. Do not spray where sparks or flame are present.
- Do not smoke while spraying.
- Keep compressor as far from spray area as possible.

Owner's Manual

Hazard Warnings (cont'd)

RISK OF HEARING LOSS



What could happen:

- Long term exposure to noise produced from the operation of air tools can lead to permanent hearing loss

How to prevent:

- Always wear ANSI S3.19 hearing protection when using a compressor.

RISK TO BREATHING/INHALATION HAZARD

What could happen:

- Abrasive tools such as grinders, sanders and cut-off tools generate dust and abrasive materials which can be harmful to human lungs and respiratory system.
- Some materials such as adhesives and tar contain chemicals whose vapors could cause respiratory damage. Read all instructions to be sure that your respirator mask will protect you.
- Always work in a clean, dry, well ventilated area.
- Never directly inhale the compressed air produced by a compressor .It is not suitable for breathing purposes.
- Be certain to read all labels when you are spraying paints or toxic materials, and follow the safety instructions.

Owner's Manual

Hazard Warnings (cont'd)

RISK OF INJURY

What could happen:

- Tools left unattended, or with the air hose attached can be activated by unauthorized persons leading to their injury and/or injury to others.
- Air tools can propel fasteners or other materials throughout the work area.
- A wrench or key that is left attached to a rotating part of the tool increases the risk of personal injury.
- Using inflator nozzles for duster applications can cause serious injury.
- Air tools can become activated by accident during maintenance or tool changes.
- Air tools can cause the work-piece to move upon contact leading to injury.
- Loss of control of the tool can lead to injury to self or others.
- Poor quality, improper, or damaged tools such as grinding wheels, chisels, sockets, drills, nailers, staples, etc., can fly apart during operation, propelling particles throughout the work area causing serious injury.
- Fasteners could ricochet or be propelled causing serious injury or property damage.
- Improperly maintained tools and accessories can cause serious injury.
- There is a risk of bursting if the tool is damaged.
- The compressor unit starts automatically. Serious injury could occur from contact with moving parts.

Owner's Manual

Hazard Warnings (cont'd)

RISK OF INJURY (cont'd)

How to prevent it:

- Remove air hose when tool is not in use and store tool in secure location away from reach of children and or untrained users.
- Use only parts, fasteners, and accessories recommended by the manufacture.
- Keep work area clean and free of clutter. Keep children and others away from area during operation of the tool.
- Keep work area well lit.
- Remove adjusting keys and wrenches before turning the tool on.
- DO NOT use inflator nozzles for duster applications.
- Remove air hose to lubricate or add grinding attachments, sanding discs, drills, etc. to the tool.
- Never carry the tool by the hose.
- Avoid unintentional starting.
- Repair servicing should be done only by an authorized service representative.
- Never operate tool while under the influence of drugs or alcohol.
- Don't overreach .Keep proper footing and balance of all times.
- Keep handles dry, clean and free from oil and grease.
- Stay alert. Watch what you are doing .Use common sense. Do not operate tool when you are tired.
- Always use tool attachments rated for the aped of the power tool.
- Never use tools which have been dropped, impacted or damaged by use.

Owner's Manual

Hazard Warnings (cont'd)

RISK OF INJURY (cont'd)

- Use only impact grade sockets on an impact wrench.
- Do not apply excessive force to the tool. Let the tool perform the work.
- Never point discharge of tool at self or others.
- Do not pull trigger unless tool contact safety device is against work surface.
- Never attempt to drive fasteners into hard surfaces such as steel, concrete, or tile when using air tools.
- Use only accessories identified by the manufacturer to be used with specific tools.
- Maintain the tool with care.
- Keep a cutting tool sharp and clean. A properly maintained tool, with sharp cutting edges reduces the risk of binding and is easier to control.
- Check for misalignment of binding or moving parts, breakage of parts, and any other condition that affects the tool's operation. If damaged, have the tool serviced before using.
- Use of an accessory not intended for use with the specific tools increases the risk of injury to persons.
- Always shut off the compressor, remove the plug from the outlet, and bleed all pressure from the system before servicing the compressor, and when the compressor is not in use.
- Do not operate the unit with the shroud removed.

Owner's Manual

Hazard Warnings (cont'd)

RISK OF ELECTRIC SHOCK

What could happen:

- Using air tools to attach electrical wiring can result in electrocution, or death.
- Improper electrical connections can result in fires, electrocution, or death.
- If the tool is not provided with an insulated gripping surface. Contact with a “live” wire makes exposed metal tool parts “live”, resulting in possible electrocution or death.
- Fasteners coming in contact with hidden electrical wiring could cause electrocution or death.

How to prevent it:

- Never attach electrical wiring with energized tools.
- Avoid body contact with grounded surfaces such as pipes, radiators, ranges, and refrigerators. There is an increased risk of electric shock if your body is grounded.
- Thoroughly investigate the work piece for possible hidden wiring before performing work.
- A licensed electrician in accordance with all local and national codes must install all wiring.
- Never use an electric air compressor outdoors when it is raining or on a wet surface, as it may cause an electric shock.

Owner's Manual

Hazard Warnings (cont'd)

RISK OF ENTANGLEMENT

What could happen:

- Tools containing moving elements or driving other moving tools (grinding wheels, sockets, sanding discs, etc.) can become entangled in hair, clothing, jewelry, and other loose objects, resulting in injury.

How to prevent it:

- Never wear loose fitting clothes or apparel that contains loose straps or ties, etc. which could become entangled in moving parts.
- Remove any jewelry, watches, identifications, necklaces, etc. which might become caught by the tool.
- Keep hands away from moving parts. Tie up or cover long hair.

Owner's Manual

Hazard Warnings (cont'd)

RISK OF CUT OR BURNS

What could happen:

- Tools which cut, shear, drill, staple punch, chisel, etc. are capable of causing serious injury.
- The pump and manifold generate high temperatures.

How to prevent it:

- Keep the working part of the tool away from hands and body.
- Do not touch the pump, manifold or transfer tube while the pump is running. Allow them to cool before handling or servicing.
- Keep children away from the compressor at all times.

Owner's Manual

Compressor Specifications

| | |
|---------------------------------|------------|
| Model Number | SP-CE358TM |
| Horse Power | 3.5 Peak |
| Tank Capacity Gallons/Liters | 8 Gallon |
| Voltage/Amps/Phase | 120/12/1 |
| Kick-In Pressure | 85 |
| Kick-Out Pressure | 125 |

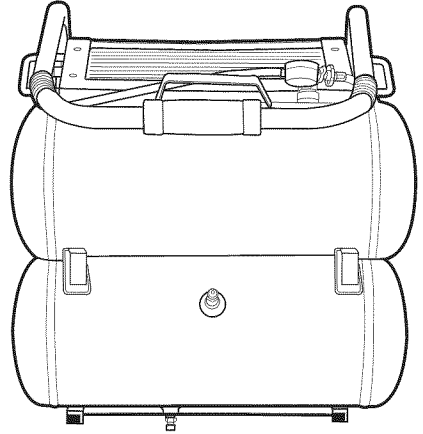

WARNING! The power cord on this product contains lead, a chemical, known to the state of California to cause cancer and birth defects or other reproductive harm. Wash hands after handling

Precautions

- Drain the moisture from the tank daily to help prevent corrosion.
- Pull the pressure relief valve ring daily to ensure proper function and clear possible obstructions
- To provide proper ventilation for cooling, the compressor must be kept at least 12 inches (31cm) from the nearest wall, in a well-ventilated area.
- Fasten the compressor securely and release tank pressure before transporting.
- Protect the air hose and electronic cord from damage and puncture. Inspect them weekly for weak or worn spots, and replace if necessary.
- To reduce the risk of electric shock, do not expose to rain. Store indoors.
- Never operate the compressor if the power cord or plug are damaged. Take the equipment to nearest authorized service center and a specialist technician will replace it.

Owner's Manual

Compressor

Basic Compressor Components

The basic components of the air compressor are the electric motor, pump, pressure switch, and tank. The electric motor (see A) powers the pump. The electric motor is equipped with an overload protector and an automatic reset. If the motor becomes overheated, the overload protector will shut it down to prevent damage to the motor. When the motor sufficiently cools, it will automatically restart.

The pump (see B) compresses the air and discharges it into the tank.

The tank (see C) stores the compressed air.

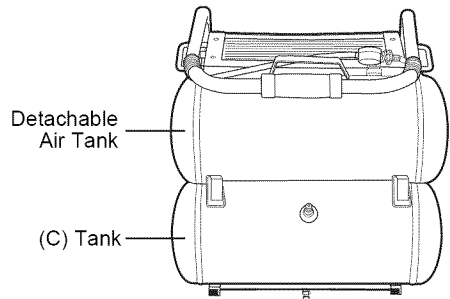

The pressure switch (located internally) shuts down the motor and relieves air pressure in the pump and transfer tube when the air pressure in the tank reaches the kick-out pressure. As compressed air is used and the pressure level in the tank drops to the kick-in pressure, the pressure switch restarts the motor automatically, without warning, and the pump resumes compressing air.

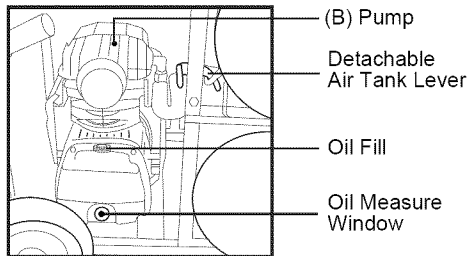
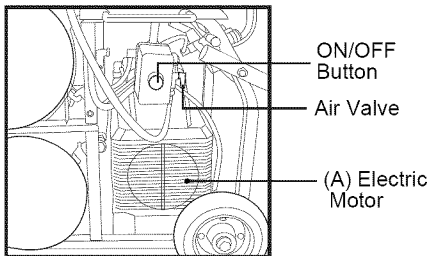

Assembling the Air Compressor

Unpack the air compressor. Inspect the unit for damage. If the unit has been damaged in transit, contact the carrier and complete a damage claim. Do this immediately because there are time limitations to damage claims. The carton should contain.

- Air Compressor
- Manual
- Oil
- Oil Plug
- Air Filter

Owner's Manual

Compressor (cont'd)

Assembling the Compressor (cont'd)

- 1) Check the compressor's serial label to ensure that you have received the model ordered, and that it has the required pressure rating for its intended use.
- 2) Place the compressor according to the following guidelines:
 - a. Position the compressor near a grounded electrical outlet.
 - b. The compressor must be at least 12 inches (31 cm) from any wall or obstruction, in a clean, dry ventilated area, to ensure sufficient air flow and cooling.
 - c. In cold climates, store portable compressors in a heated building when not in use. This will reduce problems with motor starting and freezing of water condensation.
 - d. Remove the compressor from the shipping pallet or carton and place it on the floor or a hard, level surface. The compressor must be level to ensure proper drainage of the moisture in the tank.
- 3) Connect an air hose to the compressor hose outlet.

Using the Air Tank

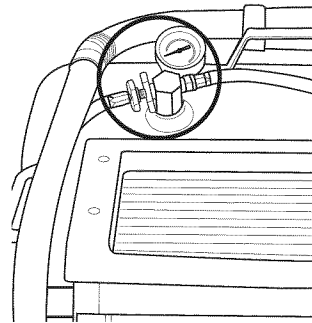
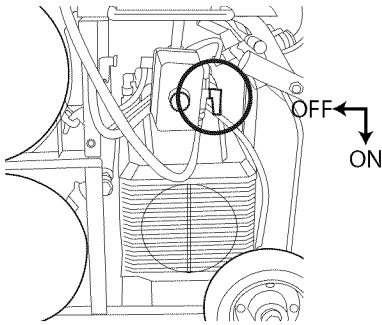

1) Turn the air valve switch to the "OFF" position.

2) Disconnect hose from top tank.

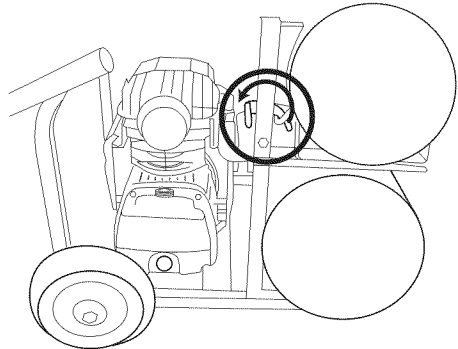
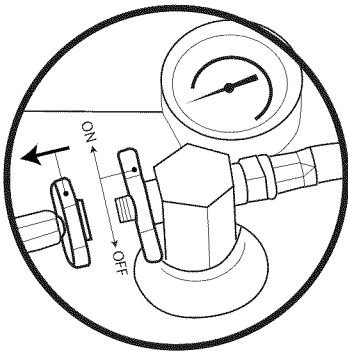

3) Disconnect hose from top tank. To use air tank turn the valve to the "ON" position.

3) Release latch to remove detachable air tank.

Owner's Manual

Compressor (cont'd)

COMPRESSOR CONTROLS

Power Button: This switch turns the compressor power ON and OFF.

Pressure Switch: This switch turns on the compressor. It is operated automatically when the power switch is in the ON position, it allows the compressor to start up or shut down automatically, without warning, depending upon air demand.

Pressure Release Valve: If the pressure switch does not shut down the motor when pressure reaches the preset level, this valve will pop open automatically to prevent over pressurization. To operate manually, pull the ring on the valve to relieve air pressure in the tank.

Pressure Gauge: This gauge measures the pressure level of the air stored in the tank. It is not adjustable by the operator, and does not indicate line pressure.

Air Pressure Regulator: This air pressure regulator enables you to adjust line pressure to the tool you are using.

Air valve switch: Releases air to the air tank

Petcock: Used to releases moisture from tank.

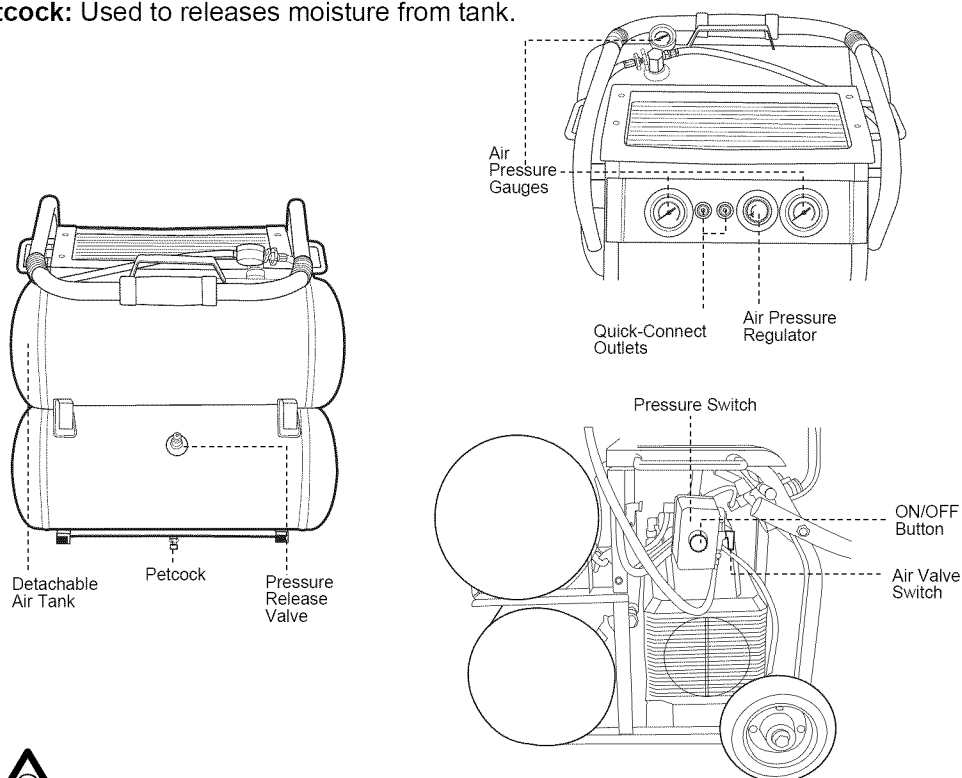

WARNING! Never exceed the maximum working pressure of the tool. Turn the knob clockwise to increase pressure, and counterclockwise to decrease pressure.

Owner's Manual

Compressor (cont'd)

COMPRESSOR CONTROLS

Regulated pressures quick connect coupler: This coupler connects to the regulated outlet pressure. To connect air hose, push coupler in. To disconnect air hose, pull the coupler collar back and separate the coupling.

Electrical Power Requirements

Electrical Wiring

Refer to the air compressor's serial label for the unit's voltage and amperage requirements. Use a dedicated circuit. For best performance and reliable starting, the air compressor must be plugged into a dedicated circuit, as close as possible to the fuse box or circuit breaker. The compressor will use the full capacity of a typical 15 amp household circuit. If other devices are on the same circuit, the compressor may fail to start. Low voltage or an overloaded circuit can result in sluggish starting that causes the motor overload protection system circuit breaker to trip, especially in cold conditions.



Note: A circuit breaker is recommended. If the air compressor is connected to a circuit protected by a fuse, use dual element time delay fuses (Buss Fusetron type "1" only).



Note: Avoid use of extension cords. If using an extension cord is necessary, be sure to use an extension with the correct specifications.

For optimum performance, plug the compressor power cord directly into a grounded wall socket. Do not use an extension cord unless absolutely necessary. Instead, use a longer air hose to reach the area where the air is needed.

If use of an extension cord cannot be avoided, the cord should be no longer than 100 feet and be a minimum wire size of 14 gauge (AWG).

Owner's Manual

Compressor (cont'd)

ELECTRICAL POWER REQUIREMENTS (cont'd)

Extension Cord

Use the chart on the right for the proper extension cord length.

Use only a 3-wire extension cord that has a 3-blade grounding plug and a 3-slot receptacle that will accept the plug of the product. Make sure your extension cord is in good condition. An undersized cord will cause a drop in line voltage as well as a loss of power and overheating. The smaller the gauge number, the heavier the cord.

| AMP RATING (120 Volts) | LENGTH OF CORD IN FEET | | | |
|---------------------------|------------------------|-----|------|------|
| | 25' | 50' | 100' | 150' |
| 10-12 | 16 | 14 | 10 | 8 |
| 12-14 | 16 | 12 | 10 | 8 |
| 14-16 | 16 | 12 | 10 | 8 |
| 16-18 | 14 | 12 | 8 | 8 |
| 18-20 | 14 | 12 | 8 | 8 |

Grounding Instructions

This product is equipped with a cord having a grounding wire and an appropriate grounding plug. The plug must be plugged into an outlet that is properly installed and grounded in accordance with all local codes and ordinance.



WARNING! IMPROPER INSTALLATION OF THE GROUNDING PLUG CAN RESULT IN A RISK OF ELECTRIC SHOCK. IF REPAIR OR REPLACEMENT OF THE CORD OR PLUG IS NECESSARY, DO NOT CONNECT THE GROUNDING WIRE TO FLAT BLADE TERMINAL. THE WIRE INSULATION HAVING AN OUTER SURFACE THAT IS GREEN WITH, OR WITHOUT, YELLOW STRIPES IS THE GROUNDING WIRE.

This product is for use on a nominal 110 volt circuit. An outlet having the same configuration as the plug. No adapter should be used with this product. Do not alter the plug to fit into a non-Ground or 2-slot receptacle.

Owner's Manual

Compressor (cont'd)

BREAKING IN THE PUMP

Make sure to put oil in the crankcase before you start the air compressor.

1. Turn the switch to the OFF position.
2. Open the petcock. Turn counterclockwise (loosen).
3. Plug in the power cord and turn switch to the ON position.
4. The compressor will start.

ALLOW THE COMPRESSOR TO RUN FOR 15 MINUTES, TO BREAK IN THE INTERNAL PARTS.



CAUTION: after about 15 minutes .If the unit does not operate properly. Shut down immediately, and contact product service center.

5. After about 15 minutes, turn the power switch to the OFF position.
6. Close the petcock. Turn in the clockwise direction.
7. Turn the power switch to the ON position .The compressor will start and fill the tank to the kick-out pressure and stop.



Note: As compressed air is used, the pressure switch will restart the motor automatically.



Note: During the initial break-in cycle, there will be a slight electrical smell as the motor brushes seat .This is normal for universal motors and will last for about 5 minutes.

OPERATING INSTRUCTIONS

Daily Startup

1. Turn the power switch to the OFF position.
2. Close the tank petcock. Turn in the clockwise direction.
3. Plug in the power cord.
4. Turn the power switch to the ON position

Owner's Manual

Compressor (cont'd)

OPERATING INSTRUCTIONS



WARNING! High temperatures are generated by the electrical motor and the pump. To prevent burns or other injuries, do not touch the compressor while it is running. Allow it to cool before handling or servicing. Keep children away from the compressor at all times.



WARNING! When adjusting from a higher to a lower pressure, turn the knob counterclockwise to reach the desired pressure. Do not exceed operating pressure of the tool or accessory being used.

5. Adjust the regulator to the working pressure of the tool. (never exceed 90 PSI)

Shut down

1. Turn the power switch to the OFF position.
2. Unplug the power cord.
3. Reduce pressure in the tank through the outlet hose. You can also pull the relief valve ring and keep it open in the tank.



WARNING! Escaping air and moisture can propel debris that may cause eye injury. Wear safety goggles when opening petcock.

4. Tip the compressor (if necessary for your model) so the petcock is at the bottom of the tank(S). Then open the petcock to allow moisture to drain from the tank.

Thermal Protector

When the motor's temperature is too high, the thermal protector will shut the motor OFF. After the motor cools down, it will restart the motor automatically preventing the motor from being damaged.

Owner's Manual

Compressor (cont'd)

MAINTENANCE



WARNING! To avoid personal injury, always shut off and unplug the compressor and relieve all air pressure from the system before performing any service on the air compressor.

LUBRICATION

This air compressor requires regular lubrication for operation.



NOTE: Use air compressor oil such as SAE-20 (API CG/CD heavy duty). Under extreme winter conditions use SAE-10 weight oil. Drain and refill the compressor oil after the first 100 hours of operation. You may also use mobile 1 synthetic 10W30



CAUTION: Compressors are shipped without oil. A small amount of oil may be present in the pump upon receipt of the air compressor. **DO NOT ATTEMPT TO OPERATE THIS AIR COMPRESSOR WITHOUT FIRST ADDING OIL TO THE CRANKCASE.** Serious damage can result from even limited operation unless filled with oil and broken in correctly. Follow initial start-up procedures closely. Damage caused by failure to add oil will void your warranty.



WARNING! Drain tank to release air pressure before removing the oil fill cap or drain plug. Not doing so could result in serious damage to the compressor as well as serious injury.

Place unit on a level surface. Remove shipping plug and slowly add compressor oil until it is even with the top of the oil fill hole .

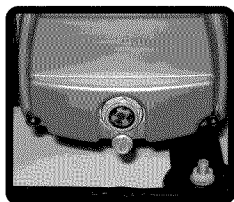

The oil should be filled to the middle of the oil level window.



OIL LEVEL WINDOW

When filling the crankcase, the oil flows very slowly into the pump. If the oil is added too quickly, it will overflow and appear to be full. Crankcase oil capacity is approximately 16 fluid ounces. Replace oil fill plug. Drain and refill the compressor oil after the first 100 hours of operation.

Owner's Manual

Compressor (cont'd)

MAINTENANCE (cont'd)

Relieve the air pressure in the system and open the petcock on the bottom of the tank to drain.



WARNING! Condensation will accumulate in the tank. To prevent corrosion of the tank from the inside, this moisture must be drained at the end of every workday, be sure to wear protective eyewear.



Note: In cold climates, drain the tank after each use to reduce problems with freezing of water condensation.

Testing for Leaks

Check that all connections are right. A small leak in any of the hoses or pipe connections will substantially reduce the performance of your air compressor. If you suspect a leak, spray a small amount of soapy water with spray bottle. If bubbles appear, repair or replace the faulty component. Do not over tighten any connections.

Storage

Before storing the compressor for a prolonged period, use an air blow gun to clean all dust and debris from the STORAGE compressor. Disconnect the power cord and coil it up. Pull the pressure relief valve all pressure from the tank. Drain all moisture from the tank. Cover the entire unit to protect it from moisture and dust.

Servicing

Perform the following maintenance at the intervals indicated below:

- Operate the pressure relief valve: Daily
- Drain air from tank: Daily
- Change oil every every 100 hours which ever comes first.

Owner's Manual

Compressor (cont'd)

TROUBLE SHOOTING



Note: Trouble shooting problems may have similar causes and solutions.

Low pressure, or not enough air, or compressor does not stop.

- Tank petcock is open

Close pet cock

- Prolonged excessive of air

Decrease amount of air used

- Compressor not large enough for job

Check air requirement of accessory. If it is higher than CFM and pressure by compressor, you need a larger compressor. Most accessories are rated at 25% of actual CFM while running continuously.

- Restricted check valve

Remove and clean or replace.

- Hole in air hose

CHECK AND REPLACE IF NECESSARY.

- Tank leaks

Replace tank



WARNING! Immediately replace tank. Do not attempt to repair.

- Blown seals

Replace any faulty seals.

Replace worn parts and reassemble with new seals.

Owner's Manual

Compressor (cont'd)

TROUBLE SHOOTING (cont'd)

Excessive starting and stopping, while not in use

- Fittings leak

Check fittings with soapy water. Tighten or reseal leaking fittings. DO NOT OVERTIGHTEN.

Replace worn parts and reassemble with new seals.

Replace any regulator internal parts.

- Regulated pressure gauge reading drops when air accessory is being used.

This is normal in some applications

Compressor not large enough

If pressure drops too low, adjust regulator while accessory is used.

Check air requirement of accessory, it may be higher than CFM pressure supplied by compressor. Most accessories are rated at 25% of actual CFM while running continuously.

- Excessive wire length

Furnish adequate power. If using extension cord, try again without it.

- Restricted air passages

Contact authorized service center.

- Back pressure in pump head

Replace check valve.

Replace pressure switch bleeder valve.

Owner's Manual

Compressor (cont'd)

TROUBLE SHOOTING (cont'd)

Overheating

- Poor ventilation

Relocate compressor to an area with cool, dry and well-circulated air.

- Dirty cooling surface

Clean all cooling surface of pump and thoroughly.

- Leaking valve

Replace worn parts and reassemble with new seals.

Motor stalls

- Low voltage

Furnish adequate power.

- Defective pressure switch bleeder valve.

Replace pressure switch bleeder valve.

Pressure relief valve opens

- Tank pressure exceeded normal operating pressure

Replace pressure switch

- Pressure switch stuck

Replace pressure switch

Motor will not run

- Tank pressure exceeds present pressure switch limit

Motor will start automatically when tank pressure drops below kick-in pressure tank.

Owner's Manual

Compressor (cont'd)

TROUBLE SHOOTING (cont'd)

Motor will not run (cont'd)

- Check valve stuck open
Remove and clean or replace.
- Pressure bleeder valve on pressure switch has not unloaded head pressure
Bleed line by moving pressure switch lever to OFF position before restarting.

If bleeder valve does not open, replace bleeder valve.

- Wrong wire gauge in extension cord
Check for proper gauge and extension cord length.
- Paint spray on internal motor parts
Bring to service center for service. Do not operate compressor in the paint spray area.
- Possible defective motor
Bring to service center for inspection and repair.
- The compressor motor shuts OFF.
The thermal protector was tripped after the compressor cools down it will automatically restart.

Owner's Manual

Compressor (cont'd)

TROUBLE SHOOTING (cont'd)

Glossary of Terms

- CFM: Cubic feet per minute; a unit of measure of air flows.
- PSI: Pounds per square inch; a unit of measure of air pressure.
- Kick-in pressure: Factory set low pressure point that starts the compressor to depressurize the tank to a higher pressure.
- Kick-out pressure: Factory set high pressure point that stops the compressor from increasing the pressure in the tank above a certain level.
- Well-ventilated: A means of providing fresh air in exchange for dangerous exhaust or vapors.
- ASME (American Society of Mechanical Engineers): Indicates that the components are manufactured, tested and inspected for the exclusive use of the air compressor.
- CSA (Canadian Standards Association): Indicates that the products that have this marking have been manufactured, tested and inspected to standards that are set by CSA.
- Canadian Standards Association (USA): Indicates that the products that have this marking have been manufactured, tested and inspected to standards that are set by CSA. These products also confirm to U.L standard 1450.

Owner's Manual

Exploded View

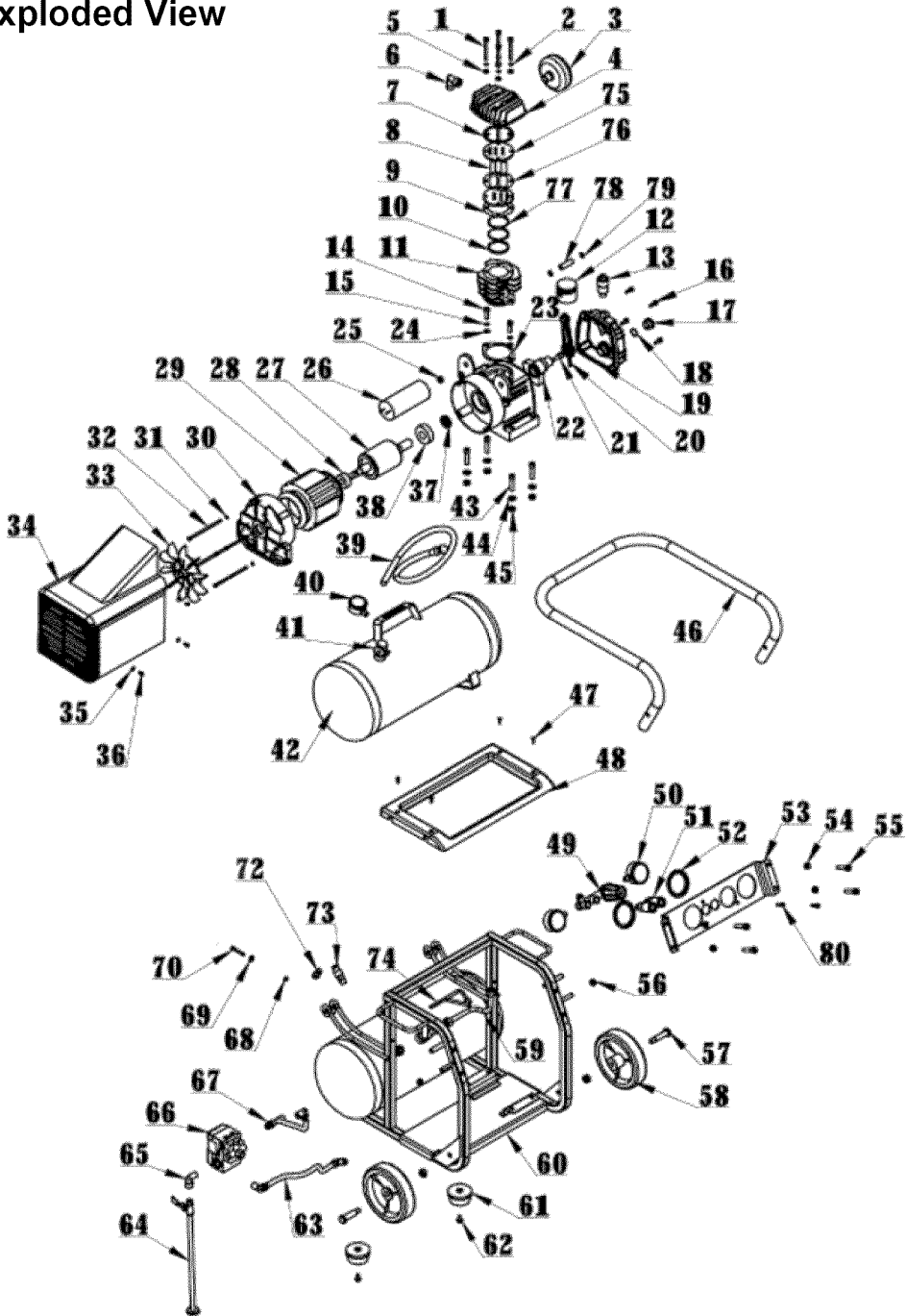

Warning: Repairs should be made by an authorized repair center. Opening this tool could invalidate your warranty.

Owner's Manual

Compressor Parts List

| No. | Description | No. | Description |
|-----------|------------------|-----------|--------------------|
| SPT283-1 | Head Bolt | SPT283-41 | Combination Valve |
| SPT283-2 | Spring Washer | SPT283-42 | Tank 1 |
| SPT283-3 | Air Filter | SPT283-43 | Head Bolt |
| SPT283-4 | Cylinder Head | SPT283-44 | Spring Washer |
| SPT283-5 | Washer | SPT283-45 | Washer |
| SPT283-6 | Elbow | SPT283-46 | Handle |
| SPT283-7 | Gasket | SPT283-47 | Head Bolt |
| SPT283-8 | Valve Plate | SPT283-48 | Tray |
| SPT283-9 | Gasket | SPT283-49 | Regulator |
| SPT283-10 | Compression Ring | SPT283-50 | Pressure Gauge |
| SPT283-11 | Cylinder | SPT283-51 | Quick-Connector |
| SPT283-12 | Piston | SPT283-52 | Rubber Bushing |
| SPT283-13 | Oil Breather Cap | SPT283-53 | Panel |
| SPT283-14 | Head Bolt | SPT283-54 | Nut |
| SPT283-15 | Spring Washer | SPT283-55 | Head Bolt |
| SPT283-16 | Head Bolt | SPT283-56 | Nut |
| SPT283-17 | Oil Sight Glass | SPT283-57 | Head Bolt |
| SPT283-18 | O-ring | SPT283-58 | Wheel |
| SPT283-19 | Crankcase Cover | SPT283-59 | Exhaust Pipe |
| SPT283-20 | Connecting Rod | SPT283-60 | Tank 2 |
| SPT283-21 | Head Bolt | SPT283-61 | Rubber Foot |
| SPT283-22 | Crank Shaft | SPT283-62 | Head Bolt |
| SPT283-23 | Gasket | SPT283-63 | Power Cord |
| SPT283-24 | Washer | SPT283-64 | Leather Hose |
| SPT283-25 | Nut | SPT283-65 | Elbow Joint |
| SPT283-26 | Capacitor | SPT283-66 | Pressure switch |
| SPT283-27 | Rotor | SPT283-67 | Lather Pipe |
| SPT283-28 | Bearing | SPT283-68 | Nut |
| SPT283-29 | Stator | SPT283-69 | Washer |
| SPT283-30 | Support Bracket | SPT283-70 | Head Bolt |
| SPT283-31 | Spring Washer | | |
| SPT283-32 | Head Bolt | SPT283-72 | Drain Cock |
| SPT283-33 | Fan | SPT283-73 | Safety Valve |
| SPT283-34 | Cover | SPT283-74 | Unloader Tube |
| SPT283-35 | Washer | SPT283-75 | Valve Assembly |
| SPT283-36 | Head Bolt | SPT283-76 | Valve Plate Spacer |
| SPT283-37 | Shaft Seal | SPT283-77 | Piston Ring |
| SPT283-38 | Bearing | SPT283-78 | Piston Ring Set |
| SPT283-39 | Leather Hose | SPT283-79 | Circlips |
| SPT283-40 | Pressure Gauge | SPT283-80 | Head Bolt |

Air Compressor

LIMITED WARRANTY

Steele® warrants to the original purchaser who uses the product in a consumer application (personal, residential or household usage) that all products covered under this Warranty are free from defects in material and workmanship for one year from the date of purchase. All products covered by this limited Warranty which are used in commercial applications (i.e. income producing) are warranted to be free of defects in material and workmanship for 90 days from the date of original purchase. Products covered under this Warranty include air compressors, air tools, service parts, pressure washers and generators. Steele® will repair or replace at Steele®'s sole option, products or components which have failed within the warranty period. Service will be scheduled according to the normal work flow and business hours at the service center location, and the availability of replacement parts. All decisions of Steele® with regard to this limited warranty shall be final. This warranty gives you specific legal rights, and you may also have other rights which vary from state to state.

RESPONSIBILITY OF ORIGINAL PURCHASER (Initial User):

To process a warranty claim on this product, DO NOT return item to the retailer. The product must be evaluated by an Authorized Warranty Service Center. For the location of the nearest Authorized Warranty Service Center contact the retailer or place of purchase. Retain original cash register sales receipt as proof of purchase for warranty work.

Use reasonable care in the operation and maintenance of the product as described in the Owner's Manual(s).

Deliver or ship the product to the nearest Authorized Warranty Service Center. Freight costs, if any, must be paid by the purchaser.

Air compressors with 60 and 80 gallon tanks will be inspected at the site of installation.

Contact the nearest Authorized Warranty Service Center that provides on-site service calls for service call arrangements.

If the purchaser does not receive satisfactory results from the Authorized Warranty Service Center, the purchaser should contact Steele®.

Owner's Manual

LIMITED WARRANTY (cont'd)

THIS WARRANTY DOES NOT COVER:

Merchandise sold as reconditioned, used as rental equipment, or floor or display models.

Merchandise that has become damaged or inoperative because of ordinary wear, misuse, cold, heat, rain, excessive humidity, freeze damage, use of improper chemicals, negligence, accident, failure to operate the product in accordance with the instructions provided in the Owner's Manual(s) supplied with the product, improper maintenance, the use of accessories or attachments not recommended by Steele®, or unauthorized repair or alterations.

Repair and transportation costs of merchandise determined not to be defective.

Costs associated with assembly, required oil, adjustments or other installation and start-up costs.

Expendable parts or accessories supplied with the product which are expected to become inoperative or unusable after a reasonable period of use.

Merchandise sold by Steele® which has been manufactured by and identified as the product of another company, such as gasoline engines. The product manufacturer's Warranty, if any, will apply.

ANY INCIDENTAL, INDIRECT OR CONSEQUENTIAL LOSS, DAMAGE, OR EXPENSE THAT MAY RESULT FROM ANY DEFECTS, FAILURE OR MALFUNCTION OF THE PRODUCT IS NOT COVERED BY THIS

WARRANTY. Some states do not allow the exclusion, so it may not apply to you.

IMPLIED WARRANTIES, INCLUDING THOSE OF MERCHANTABILITY OR FITNESS FOR A PARTICULAR PURPOSE, ARE LIMITED TO ONE YEAR

FROM THE DATE OF ORIGINAL PURCHASE. Some states do not allow

limitations on how long an implied warranty lasts, so the above limitations may not apply.