

Operator's Manual

CRAFTSMAN®

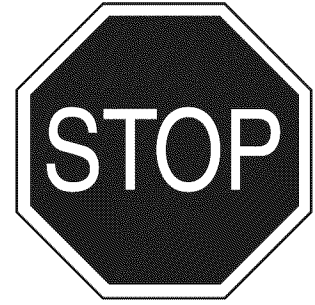

42"- 2 STAGE SNOW THROWER TRACTOR ATTACHMENT

Model No. 486.24837

DO NOT RETURN TO STORE
For Missing Parts or Assembly
Questions Call 1-866-576-8388

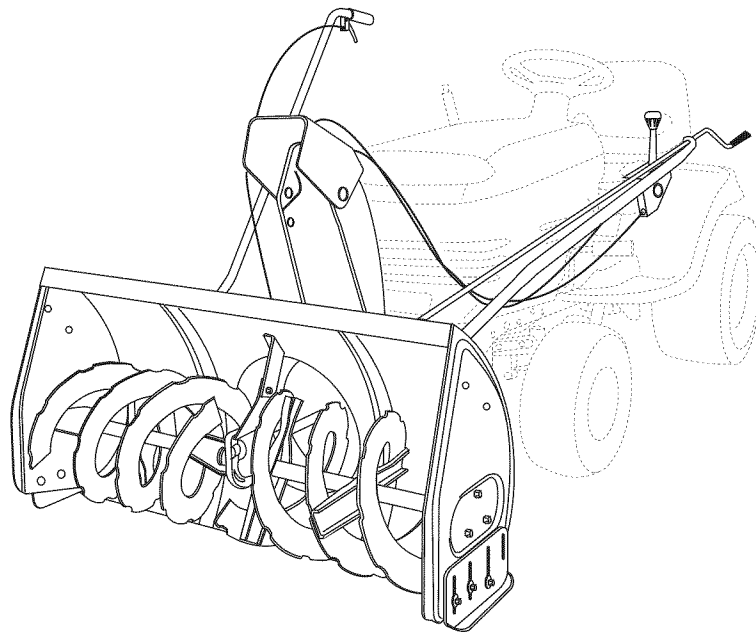

FOR TRACTORS WITH MODEL NUMBERS BEGINNING WITH 917.

CAUTION:

Before using this product, read this manual and follow all Safety Rules and Operating Instructions.

- Safety
- Assembly
- Operation
- Maintenance
- Parts

Sears, Roebuck and Co., Hoffman Estates, IL 60179 U.S.A.
www.sears.com/craftsman

TABLE OF CONTENTS

ACCESSORIES.....2	SERVICE AND ADJUSTMENTS.....28
SAFETY RULES.....3	STORAGE29
FULL SIZE HARDWARE CHART.....4	TROUBLESHOOTING.....29
CARTON CONTENTS.....6	REPAIR PARTS ILLUSTRATION.....30,32,34
ASSEMBLY.....7	REPAIR PARTS LIST.....31,33,34
OPERATION.....26	SLOPE GUIDE35
MAINTENANCE27	PARTS ORDERING/SERVICEBACK COVER

WARRANTY

ONE YEAR FULL WARRANTY

When operated and maintained according to the instructions supplied with it, if this Snow Thrower fails due to a defect in material or workmanship within one year from the date of purchase, call 1-800-4-MY-HOME® to arrange for free repair (or replacement if repair proves impossible).

If this product is used for commercial or rental purposes, this warranty applies for only 90 days from the date of purchase.

This warranty gives you specific legal rights, and you may also have other rights which vary from state to state.

Sears, Roebuck and Co., D817WA, Hoffman Estates, IL 60179

ACCESSORIES AND ATTACHMENTS

These and other accessories are recommended for use with your unit. Call 1-800-4-MY-HOME® to find out if they are available. If available, they may be purchased at most Craftsman outlets or by calling 1-800-4-MY-HOME®.

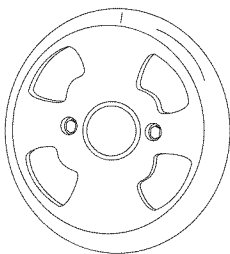
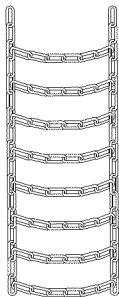
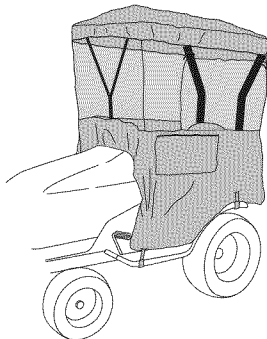
<p>WHEEL WEIGHT</p> 	<p>TIRE CHAINS</p> 	<p>SNOW CAB</p> 
--	---	--

<p>The model number and serial numbers will be found on a decal attached to the snow thrower.</p> <p>You should record both the serial number and the date of purchase and keep in a safe place for future reference.</p>	<table style="width: 100%; border: none;"> <tr> <td style="border: none;">MODEL NUMBER:</td> <td style="border: none;">486.24837</td> </tr> <tr> <td style="border: none;">SERIAL NUMBER:</td> <td style="border: none;">_____</td> </tr> <tr> <td style="border: none;">DATE OF PURCHASE:</td> <td style="border: none;">_____</td> </tr> </table>	MODEL NUMBER:	486.24837	SERIAL NUMBER:	_____	DATE OF PURCHASE:	_____
MODEL NUMBER:	486.24837						
SERIAL NUMBER:	_____						
DATE OF PURCHASE:	_____						



SAFETY



Any power equipment can cause injury if operated improperly or if the user does not understand how to operate the equipment. Exercise caution at all times, when using power equipment.

- Read this owner's manual carefully and know how to operate your snow thrower and how to stop the unit and disengage the controls quickly.
- Never allow children to operate the equipment.
- Never allow adults to operate the equipment without proper instruction.
- Keep the area of operation clear of all persons, especially small children, and pets.
- Thoroughly inspect the area where the equipment is to be used and remove all door mats, sleds, boards, wires and other foreign objects.
- Disengage all clutches and shift into neutral before starting engine.
- Do not operate equipment without wearing adequate winter outer garments.
- Wear substantial footwear which will protect feet and improve footing on slippery surfaces.
- Check fuel before starting the engine. Do not remove the fuel cap or fill the fuel tank while the engine is running or hot. Do not fill the fuel tank indoors. Gasoline is an extremely flammable fuel.
- Make sure the snow thrower height is adjusted to clear the type surface it will be used on.
- Do not use the snow thrower without wheel weights attached to the tractor.
- Never make any adjustments while the engine is running.
- Always wear safety glasses or eye shield during operation or while performing adjustment or repair.
- Do not place hands or feet near rotating parts. Keep clear of the discharge opening at all times.
- Use extreme caution when operating on or crossing gravel surfaces.
- Do not carry passengers.
- After striking a foreign object, stop the engine, remove the wire from the spark plug and then thoroughly inspect the snow thrower for damage. Repair any damage before restarting and operating the snow thrower.
- If the snow thrower starts to vibrate abnormally, stop the engine immediately and check for the cause. Vibration is generally a warning of trouble.
- Stop the engine whenever you leave the operating position, before unclogging the snow thrower or making any adjustments or inspections.
- Take all possible precautions when leaving the unit unattended. Disengage the attachment clutch lever or switch, lower the snow thrower, shift into neutral, set the parking brake, stop the engine and remove the key.
- When cleaning, repairing or inspecting, make certain all moving parts have stopped. Disconnect the spark plug wire and keep it away from the plug to prevent accidental starting.
- Do not run engine indoors except when transporting the snow thrower in or out of the building. Open the outside doors. Exhaust fumes are dangerous.
- Do not clear snow across the face of slopes. Exercise extreme caution when changing direction on slopes. Do not attempt to clear steep slopes. Refer to the slope guide on page 35 of this manual.
- Never operate the snow thrower without guards, plates or other safety protection devices in place.
- Never operate the snow thrower near glass enclosures, automobiles, window wells, drop offs etc. without proper adjustment of the snow thrower discharge angle.
- Never direct discharge at bystanders or allow anyone in front of the snow thrower.
- Never run the snow thrower into material at high speeds.
- Do not overload the machine capacity by attempting to clear snow at too fast a rate.
- Never operate the machine at high transport speed on slippery surfaces. Look behind and use care when backing up.
- Watch for traffic and stay alert when crossing or operating near roadways.
- Disengage power to the snow thrower when transporting or when not in use.
- Use only attachments and accessories approved by the manufacturer of the snow thrower (such as wheel weights, counter weights, cabs etc.)
- Never operate the snow thrower without good visibility or light.



Look for this symbol to point out important safety precautions. It means — **Attention!! Become alert!! Your safety is involved.**

HARDWARE PACKAGE CONTENTS

SHOWN ACTUAL SIZE

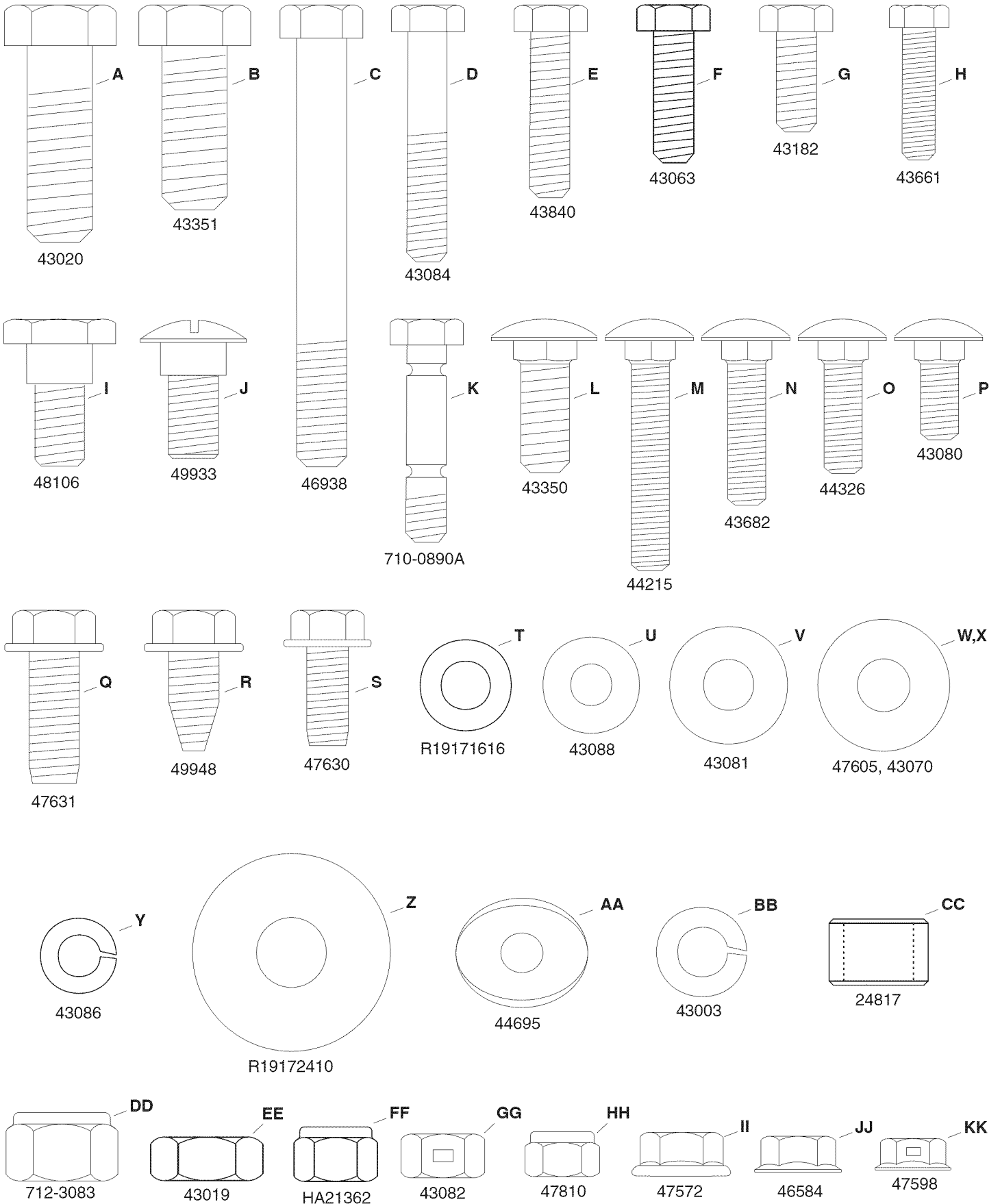

NOT SHOWN ACTUAL SIZE

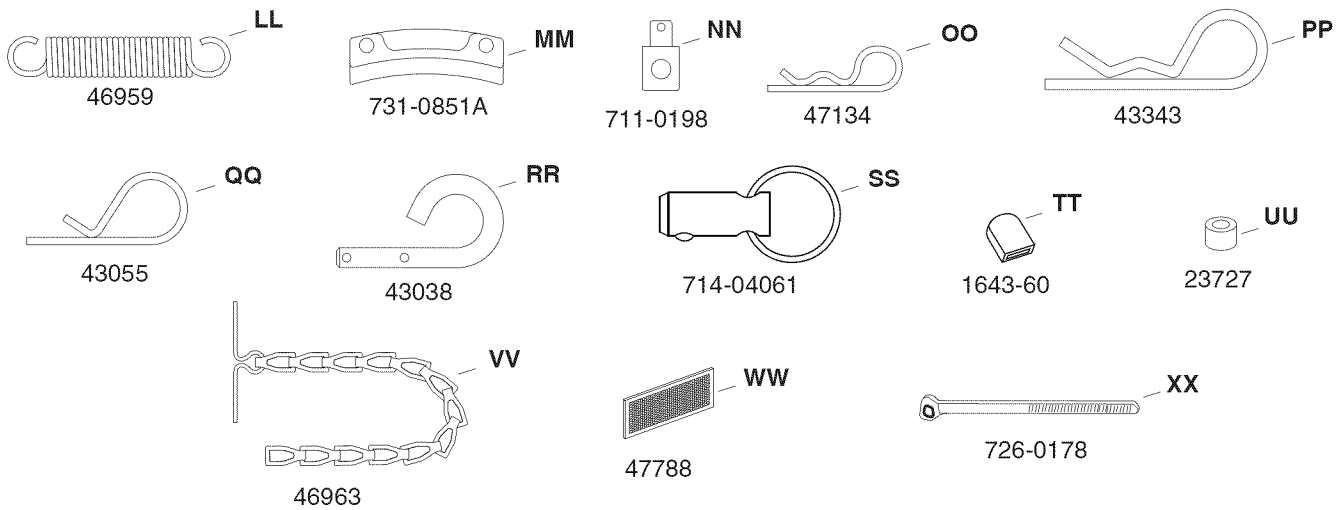

IMPORTANT: Not all items supplied in the hardware bag will be needed for your particular tractor. Unneeded items may be discarded after you have completed assembly and checked operation of unit. **DO NOT DISCARD** the two spare shear bolts (K) and 5/16" nylock nuts (HH). Refer to the Service and Adjustments section on page 28.

REF.	QTY.	DESCRIPTION	REF.	QTY.	DESCRIPTION
A	2	Hex Bolt, 1/2" x 1-1/2"	AA	2	Bowed Washer
B	2	Hex Bolt, 1/2" x 1-1/4"	BB	7	Lock Washer, 3/8"
C	1	Hex Bolt, 3/8" x 3-1/4"	CC	2	Spacer, 1/2"
D	2	Hex Bolt, 5/16" x 1-3/4"	DD	4	Nylock Nut, 1/2"
E	2	Hex Bolt, 5/16" x 1-1/4"	EE	4	Jam Nut, 1/2"
F	4	Hex Bolt, 5/16" x 1"	FF	6	Nylock Nut, 3/8"
G	8	Hex Bolt, 5/16" x 3/4"	GG	2	Hex Lock Nut, 3/8"
H	6	Hex Bolt, 1/4" x 1"	HH	21	Nylock Nut, 5/16" (2 spare parts)
I	4	Shoulder Bolt, Hex Head	II	10	Flanged Nut, 3/8"
J	2	Shoulder Bolt, Round Head	JJ	1	Flanged Nut, 5/16"
K	2	Shear Bolt (spare parts)	KK	6	Flanged Nut, 1/4"
L	6	Carriage Bolt, 3/8" x 1"	LL	1	Spring
M	2	Carriage Bolt, 5/16" x 1-3/4"	MM	3	Chute Keeper
N	2	Carriage Bolt, 5/16" x 1-1/4"	NN	1	Trunnion
O	4	Carriage Bolt, 5/16" x 1"	OO	4	Hairpin Cotter, 5/64"
P	2	Carriage Bolt, 5/16" x 3/4"	PP	4	Hairpin Cotter, 1/8"
Q	6	Hex Bolt, 3/8" x 1" (Thread Forming)	QQ	1	Hairpin Cotter, 3/32"
R	2	Hex Bolt, 3/8" x 3/4" (Thread Forming)	RR	2	Lock Pin
S	2	Hex Bolt, 5/16" x 3/4" (Thread Forming)	SS	2	Quick Release Pin
T	4	Washer, 1/2" x 1"	TT	1	Plastic Cap
U	7	Washer, 1/4"	UU	1	Spacer, 3/8"
V	22	Washer, 5/16" (Extra washers included)	VV	2	Chain, Tensioning
W	1	Washer, 3/8" (Thin)	WW	2	Tail Reflector
X	3	Washer, 3/8" Standard	XX	2	Nylon Tie
Y	2	Lock Washer, 5/16"			
Z	8	Washer, 1/2" x 1-1/2"			

CARTON CONTENTS

- | | |
|---|--|
| 1. Housing Assembly | 12. Front Pulley Frame Bracket (2) |
| 2. Lift Handle and Cable | 13. V-Belt, Drive 56" (#48138) |
| 3. Chute Crank Rod Assembly | 14. V-Belt, Drive 55" (#46989) |
| 4. Support Tube, Crank Rod | 15. V-Belt, Auger (Attached to Housing Assembly) |
| 5. Engagement Rod (Not used on some models) | 16. L.H. Hanger Bracket (Outside Mounting) |
| 6. Cable Bracket | 17. R.H. Hanger Bracket (Outside Mounting) |
| 7. Engine Pulley Keeper (Not used on some models) | 18. L.H. Hanger Bracket (Inside Mounting) |
| 8. Chute and Control Cable Assembly | 19. R.H. Hanger Bracket (Inside Mounting) |
| 9. Clutch Idler Assembly | 20. Left Hand Side Plate |
| 10. Rear Pulley Frame Bracket (2) | 21. Right Hand Side Plate |
| 11. Anti-rotation Bracket. | 22. Pulley |
| | 23. Spacer, 3/8" |

ONLY ITEMS NEEDED FOR MODEL 917.____ TRACTORS ARE SHOWN

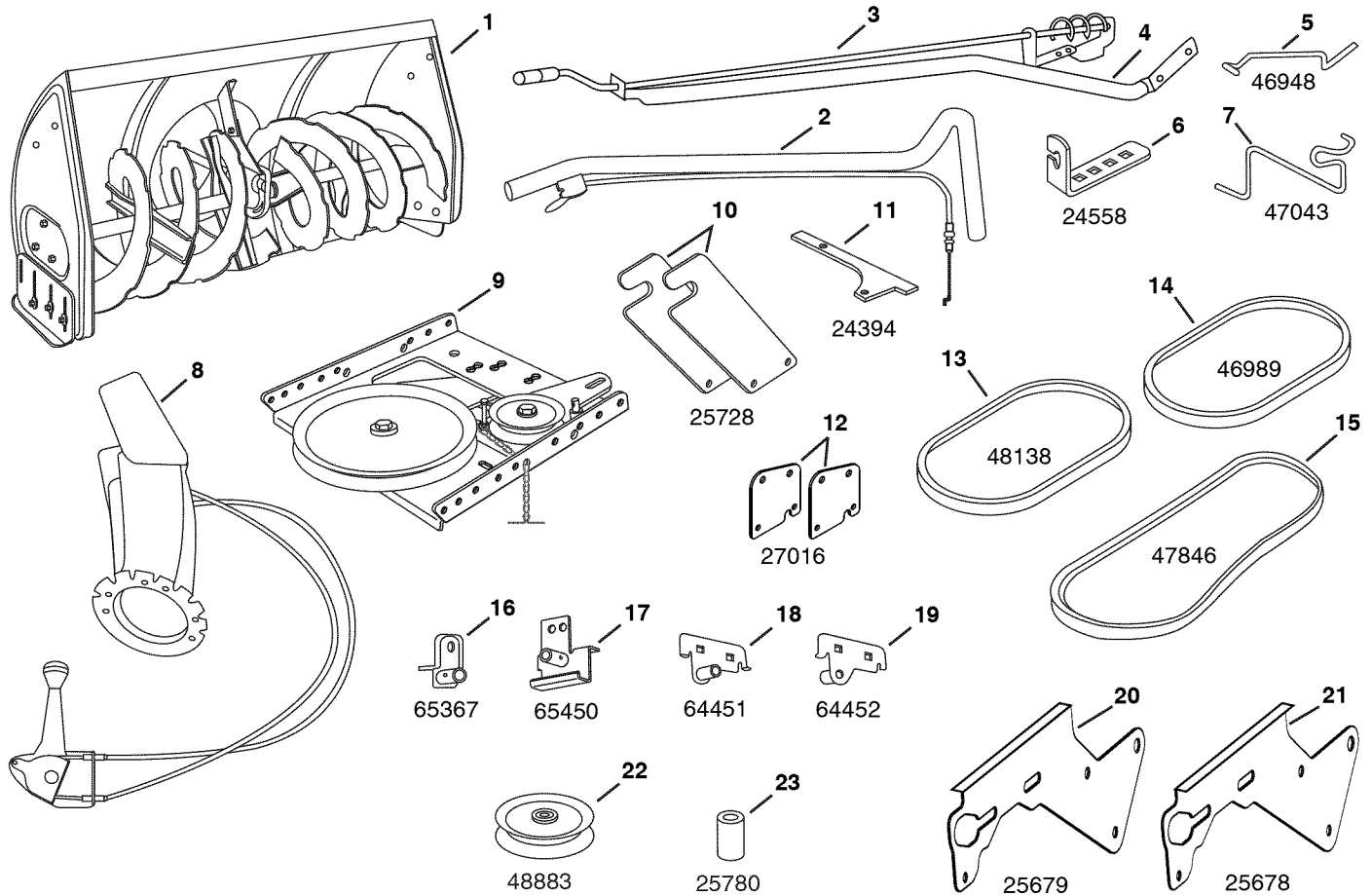

ASSEMBLY

LOCATE TRACTOR'S MODEL LABEL

Look under your tractor seat to locate the model number label shown below. This manual is for tractors with model numbers that start with 917 as shown below.

917 MODEL TRACTORS

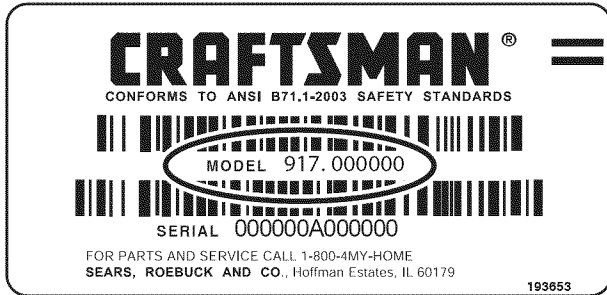

IMPORTANT: If your model number starts with 247, use the owner's manual and the parts that are contained in the other parts bag.

TOOLS REQUIRED FOR ASSEMBLY

- (2) 7/16" Wrenches
- (2) 1/2" Wrenches
- (2) 9/16" Wrenches
- (2) 3/4" Wrenches
- (1) Screw Driver
- (1) Knife

ADDITIONAL ITEMS REQUIRED

General Purpose Grease

REMOVAL OF PARTS FROM CARTON

- Remove all loose parts, parts bags and hardware bags from the carton. Lay out and identify parts and hardware using the illustrations on pages 4, 5 and 6. The parts bag labeled for 247 model tractors will not be needed.

IMPORTANT: Not all items supplied in the hardware bag will be needed for your particular tractor. Unneeded items may be discarded after you have completed assembly and checked operation of unit. **DO NOT DISCARD** the two spare shear bolts and 5/16" nylock nuts. Refer to the Service and Adjustments section on page 28.



CAUTION: Before starting to assemble the snow thrower, remove the spark plug wire(s), set the parking brake and remove the key from the tractor ignition.

TRACTOR PREPARATION

Before performing these instructions, refer to the Service and Adjustments section of your tractor owner's manual for specific safety instructions.

- Allow engine, muffler and exhaust deflector to cool before beginning.
- Remove any front or rear attachment which is mounted to your tractor.
- Remove the mower deck. Refer to your tractor owner's manual for removal instructions. Mark all loose parts and save for reassembly.
- Remove the tractor hood. Refer to your tractor owner's manual for removal instructions.

IMPORTANT: Right hand (R.H.) and left hand (L.H.) side of the tractor are determined from the operators position while seated on the tractor.

IDENTIFY YOUR TRACTOR

STEP 1: (SEE FIGURE 1)

- Look under the front of your tractor. If there is a single mower deck suspension bracket located underneath the middle of the front axle, continue on to step 2. **If your tractor does not have a mower deck suspension bracket underneath the middle of the front axle, skip to step 21 on page 14** for tractors with dual suspension brackets.

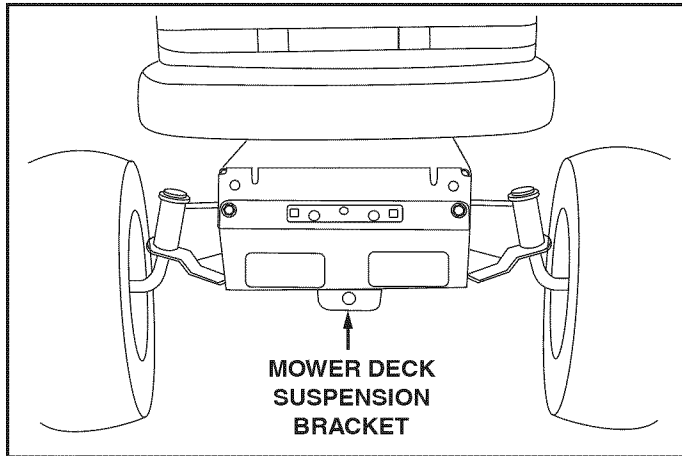

FIGURE 1

INSTRUCTIONS FOR TRACTORS WITH SINGLE FRONT DECK SUSPENSION BRACKET

STEP 2: (SEE FIGURE 2)

- Remove the browning shield from the front of the tractor as shown. Hold onto the shield as you remove the second screw to prevent it from falling.
- Be sure to reinstall the browning shield when so instructed in step 3.

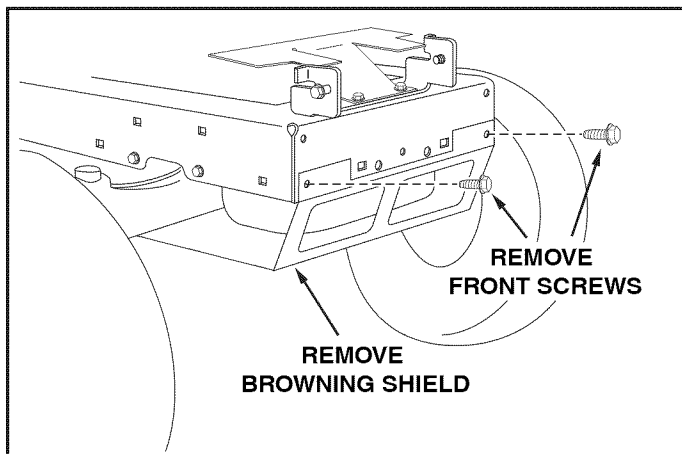

FIGURE 2

RIGHT SIDE VIEW

INSTALL SIDE PLATES

STEP 3: (SEE FIGURE 3)

- Fasten the R.H. Side Plate (bend facing out) to the front three holes in the tractor frame using three 3/8" x 1" carriage bolts, three 1/2" x 1-1/2" washers (see note) and three 3/8" flange nuts. For the rear hole, use a 5/16" x 1" carriage bolt, a 1/2" x 1-1/2" washer and a 5/16" nylock nut. Place the washers between the tractor frame and the side plate. Repeat for L.H. side plate.
- Reinstall the browning shield onto the tractor frame using the original screws.

NOTE: If there is an engine mounting plate (shown with dotted lines) leave the washer off the bolt that goes through the plate.

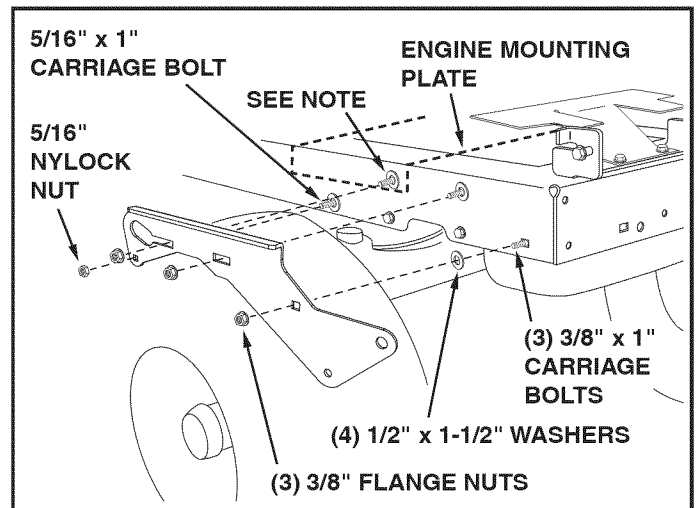

FIGURE 3

RIGHT SIDE VIEW

STEP 4: (SEE FIGURE 4)

- Assemble a shoulder bolt and a 3/8" washer to the outside of R.H. side plate, securing it with a 3/8" flanged nut. Repeat for L.H. side plate.

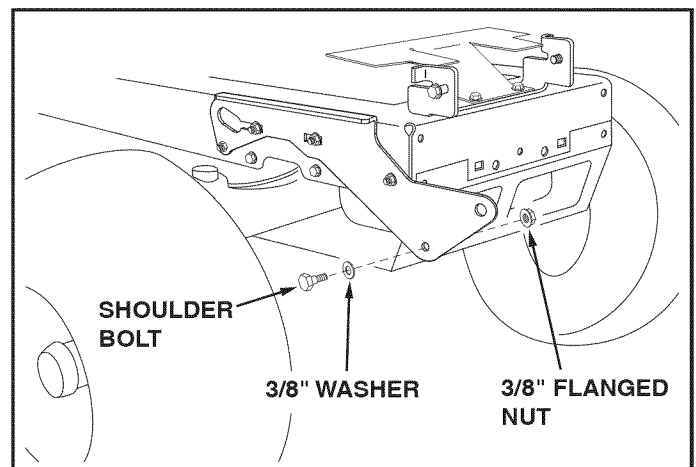

FIGURE 4

RIGHT SIDE VIEW

INSTALL HANGER BRACKETS AND SHOULDER BOLTS TO OUTSIDE OF FRAME

STEP 5: (SEE FIGURE 5)

- Remove the bolt, if present, in the hole directly behind the brake rod on the left side of the tractor frame.
- Attach the L.H. Hanger Bracket (tube facing out) to the hole using a 5/16" x 3/4" self threading bolt.
- Install a round head shoulder bolt into the hole that is 9-1/2" to the rear of the bolt you just installed. Secure it with a 3/8" flange nut on the inside of the frame.

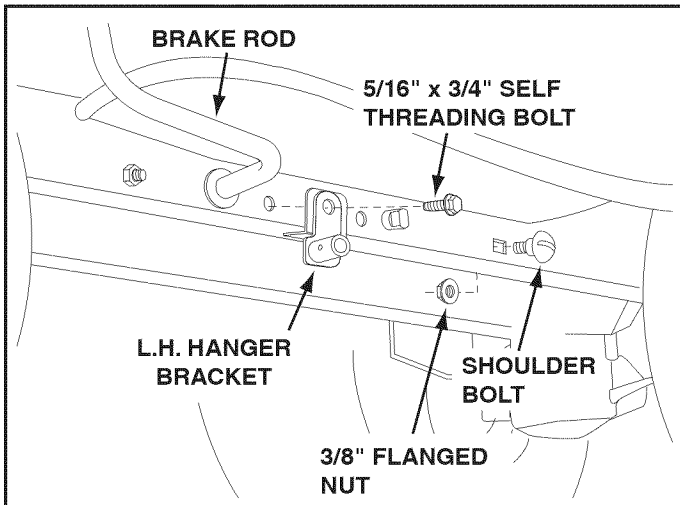

FIGURE 5

LEFT SIDE VIEW

STEP 6: (SEE FIGURE 6)

- Remove the bracket, if present, from the hole directly behind the end of the brake rod on the right side of the tractor frame. Store the bracket and bolt.
- Attach the R.H. Hanger Bracket to the hole using a 5/16" x 3/4" self threading bolt.
- Install a round head shoulder bolt into the hole that is 9-1/2" to the rear of the bolt you just installed. Secure it with a 3/8" flange nut on the inside of the frame.

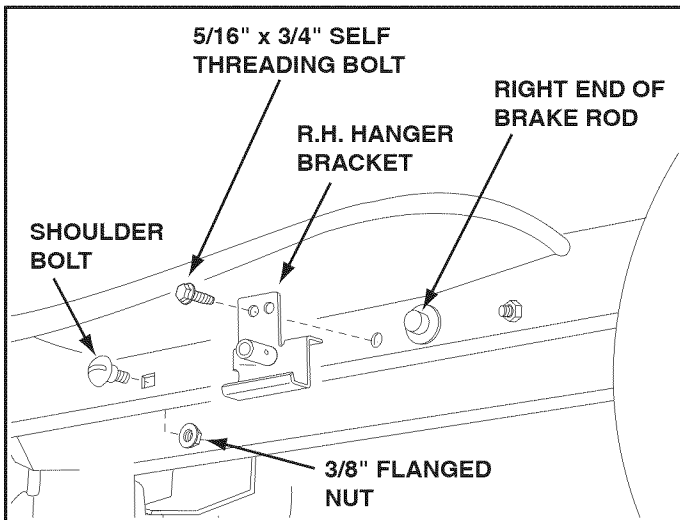

FIGURE 6

RIGHT SIDE VIEW

**THIS SECTION IS FOR TRACTORS WITH A
MANUAL ATTACHMENT CLUTCH**

If your tractor has an electric attachment clutch go to step 14 on page 12.

STEP 7: (SEE FIGURE 7)

- Attach the cable bracket to the double hole in the clutch/idler assembly as shown, using a 5/16" x 3/4" carriage bolt and a 5/16" nylock nut. Place the bolt in the front hole of the bracket and in the end of the hole closest to the pulley. **Do not tighten yet.**

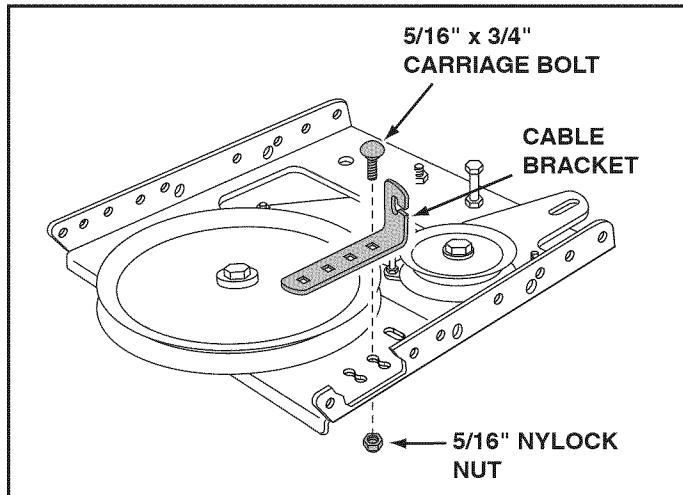

FIGURE 7

STEP 8: (SEE FIGURE 8)

- Attach the pulley (long end of hub facing down) and the 3/8" spacer to the clutch/idler assembly. Use a 3/8" x 3-1/4" hex bolt, a 3/8" washer, a 3/8" lock washer and a 3/8" hex lock nut.
- Insert a tensioning chain through the hole shown and attach the end link to the spring on the lower idler arm.

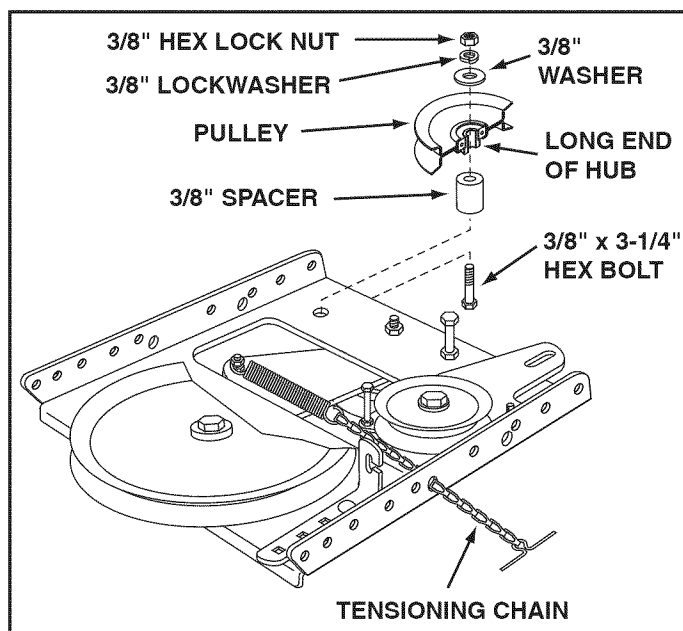

FIGURE 8

STEP 9: (SEE FIGURE 9)

- Attach each rear pulley frame bracket to the inside of the clutch/idler assembly using two 5/16" x 3/4" hex bolts, 5/16" washers and 5/16" nylock nuts.
- Attach each front pulley frame bracket to the inside of the clutch/idler assembly using two 5/16" x 1" hex bolts, four 5/16" washers and two 5/16" nylock nuts.

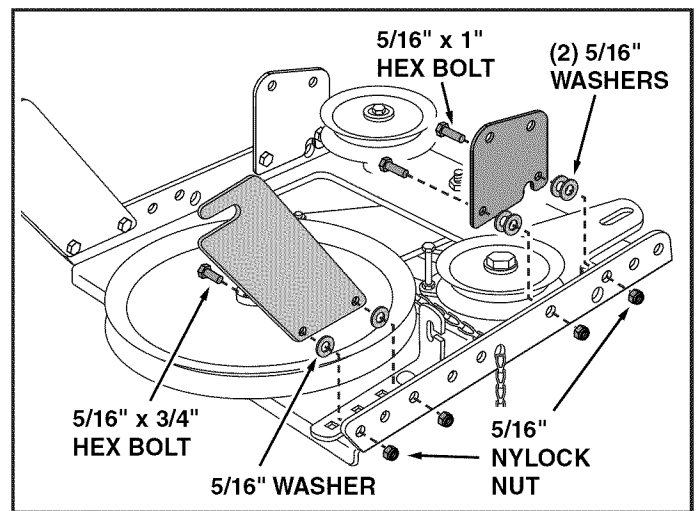

FIGURE 9

STEP 10: (SEE FIGURE 10)

- Three different length drive belts are included with your snow thrower. Tractors with manual attachment clutches and single front deck suspension brackets use the 56" drive belt with #48138 printed on the outside of the belt. **DO NOT USE** the other drive belts.
- Slightly loosen the hex bolt next to the flat idler pulley. Install the drive belt down between the hex bolt and the flat idler pulley with the flat side of the belt against the pulley. Retighten the hex bolt.
- Loop the belt around the large v-pulley, placing it between the v-pulley and the hex bolt next to the pulley. Place the belt to the inside of the other flat idler pulley.

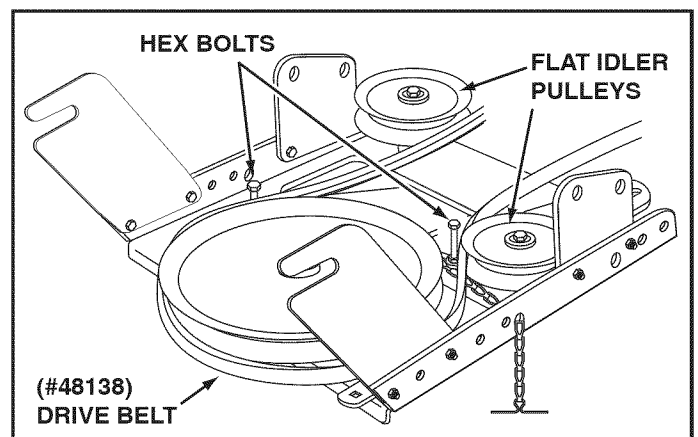

FIGURE 10



Did you select the correct drive belt for your tractor? Using the wrong length belt may cause premature bearing or belt failure.

STEP 11: (SEE FIGURE 11)

- Find the cable clip that is attached to the left side of the tractor frame underneath the footrest. Open the clip and remove the mower clutch cable. **Do not remove** the clip from the tractor frame. The cable reattaches to the clip when using the mower deck.
- Move the attachment clutch lever on the dash panel to the disengaged position.
- Place the clutch/idler assembly on the floor on the left side of the tractor.
- Attach the tractor's mower clutch cable to the cable bracket on the clutch/idler assembly. Secure the cable housing guide (groove down) to the cable bracket using the original collar and a 5/64" hair cotter pin.
- Place a 1/4" spacer on the welded pin on the idler arm. Hook the end of the clutch cable spring over the pin and secure it with a 1/4" washer and a 5/64" hair cotter pin.
- Align cable bracket with welded pin and tighten the nut assembled in step 9.

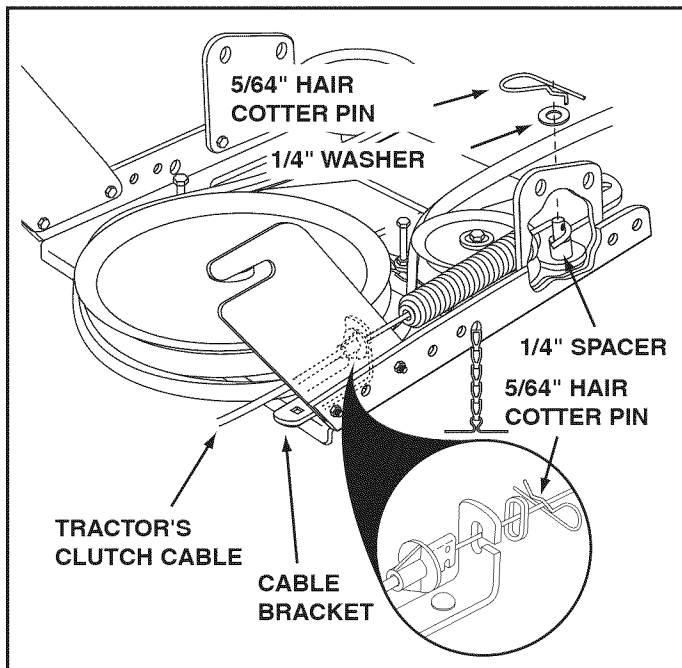

FIGURE 11

ATTACH CLUTCH IDLER ASSEMBLY TO TRACTOR

STEP 12: (SEE FIGURE 12)

- Attach the clutch/idler assembly to the tractor frame. Hook the notched rear pulley frame brackets onto the two shoulder bolts assembled to the outside of the tractor frame. Lift the front of the assembly and attach it to the R.H. and L.H. hanger brackets using two pivot lock pins and 1/8" hairpin cotters.
- Loosely attach the mower clutch cable to the left side of the tractor frame with a nylon tie. **Do not** pull the nylon tie completely tight. The cable may need to be removed from the nylon tie when using the mower deck.

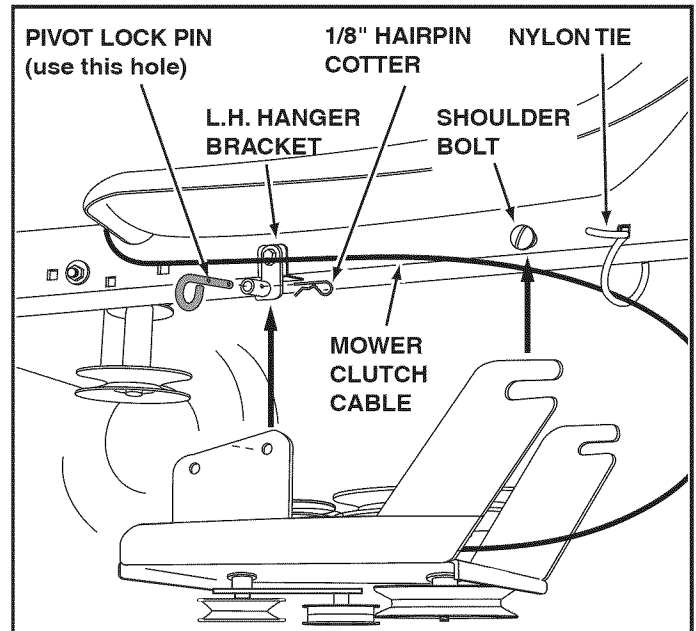

FIGURE 12

VIEWED FROM LEFT SIDE

STEP 13: (SEE FIGURE 13)

- Assemble the drive belt onto the engine pulley first and then onto the large pulley on top of the clutch/idler assembly. The belt must be placed inside the engine pulley belt keeper(s) and between the large pulley and the keeper bolt next to it.

IMPORTANT: Do Not assemble the "V" belt outside of the engine pulley keepers or outside of the keeper bolt next to the large pulley.

- Go to step 48 on page 22.

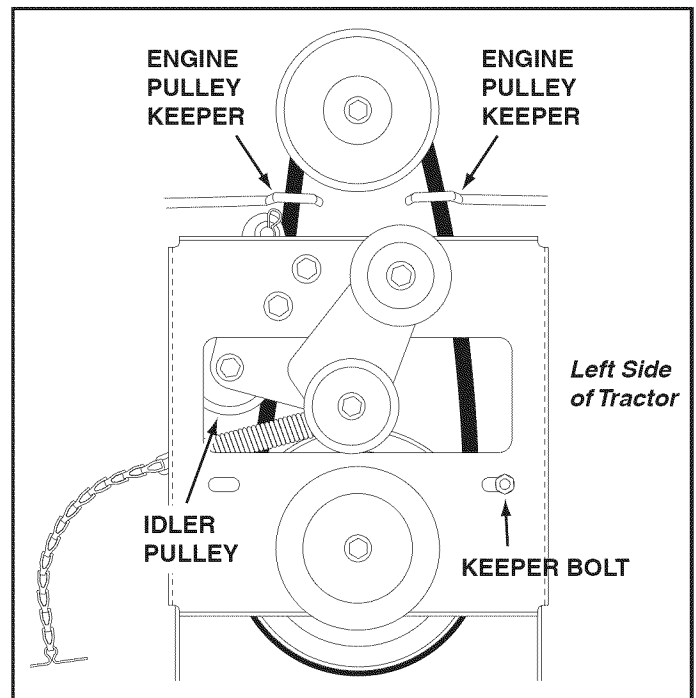

FIGURE 13

VIEWED FROM UNDERNEATH

THIS SECTION IS FOR TRACTORS WITH AN ELECTRIC ATTACHMENT CLUTCH

STEP 14: (SEE FIGURE 14)

- Turn the clutch idler assembly upside down.
- Hook the spring onto the end of the bolt that extends through the nut on the bottom of the upper idler arm. Install a 3/8" hex lock nut onto the bolt, leaving enough space for the spring to pivot.

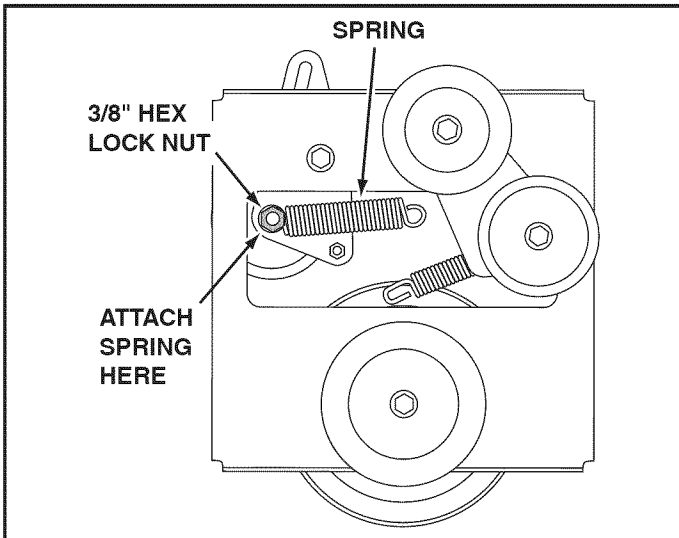

FIGURE 14

STEP 15: (SEE FIGURE 15)

- Insert tensioning chains through the holes shown and attach to the springs on the upper and lower idler arms.
- Install a 3/32" hairpin cotter in the chain attached to the upper idler arm, placing it in the fifth link from the spring.

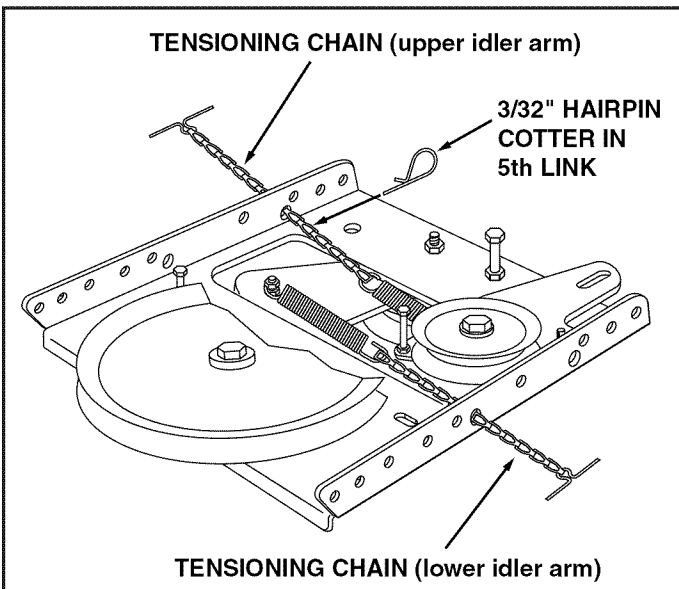

FIGURE 15

STEP 16: (SEE FIGURE 16)

- Attach each rear pulley frame bracket to the inside of the clutch/idler assembly using two 5/16" x 3/4" hex bolts, 5/16" washers and 5/16" nylock nuts.
- Attach each front pulley frame bracket to the inside of the clutch/idler assembly using two 5/16" x 1" hex bolts, four 5/16" washers and two 5/16" nylock nuts.

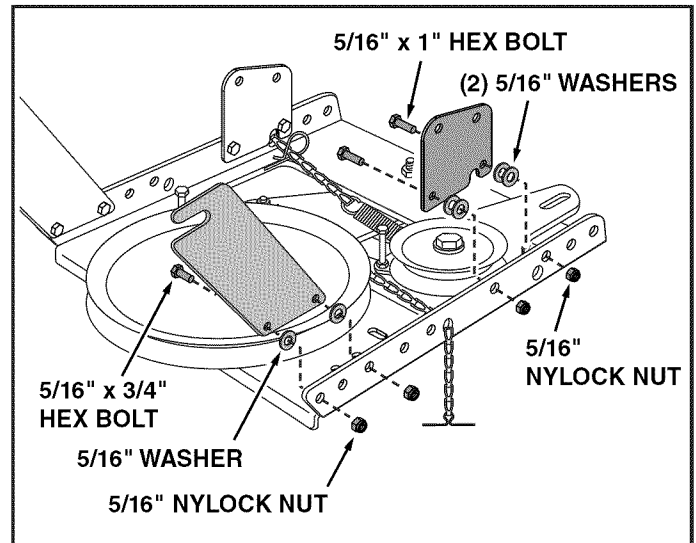

FIGURE 16

**SELECT THE CORRECT DRIVE BELT
(Electric clutch tractors with a single front deck suspension bracket)**

STEP 17: (SEE TABLE 1)

- Three different length drive belts are included with your snow thrower. Select one of the two belts listed below that is correct for your tractor. The part number is printed on the outside of the belt.
- Set aside the belts that are not for your tractor, to avoid accidentally using them.

55" BELT (PART #46989)		
TRACTOR TYPE	DECK SIZE	CLUTCH TYPE
(LT) Lawn Tractor	38", 42"	Electric
56" BELT (PART #48138)		
TRACTOR TYPE	DECK SIZE	CLUTCH TYPE
(LT) Lawn Tractor	48"	Electric
(GT) Garden Tractor	48", 54"	Electric

TABLE 1

STEP 18: (SEE FIGURE 17)

- Turn the clutch/idler assembly right side up.
- Slightly loosen the hex bolt next to the flat idler pulley. Install the drive belt down between the hex bolt and the flat idler pulley with the flat side of the belt against the pulley. Retighten the hex bolt.
- Loop the belt around the large v-pulley, placing it between the v-pulley and the hex bolt next to the pulley.

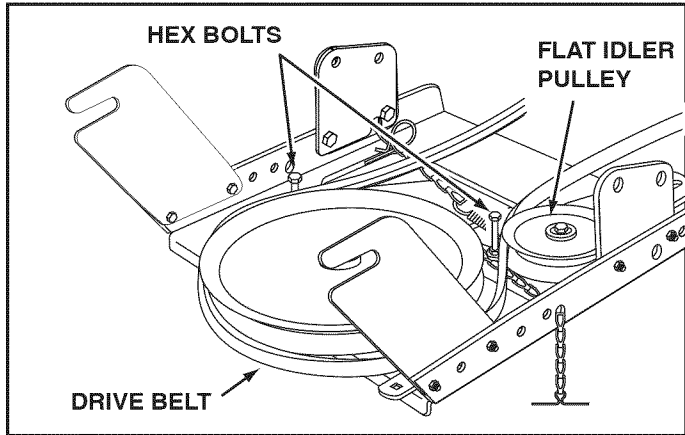

FIGURE 17

STOP Did you choose the correct drive belt for your tractor? Using the wrong length belt may cause premature bearing or belt failure.

STEP 19: (SEE FIGURE 18)

- Attach the clutch/idler assembly to the tractor frame. Hook the notched rear pulley frame brackets onto the two shoulder bolts assembled to the outside of the tractor frame. Lift the front of the assembly and attach it to the R.H. and L.H. hanger brackets using two pivot lock pins and 1/8" hairpin cotters.

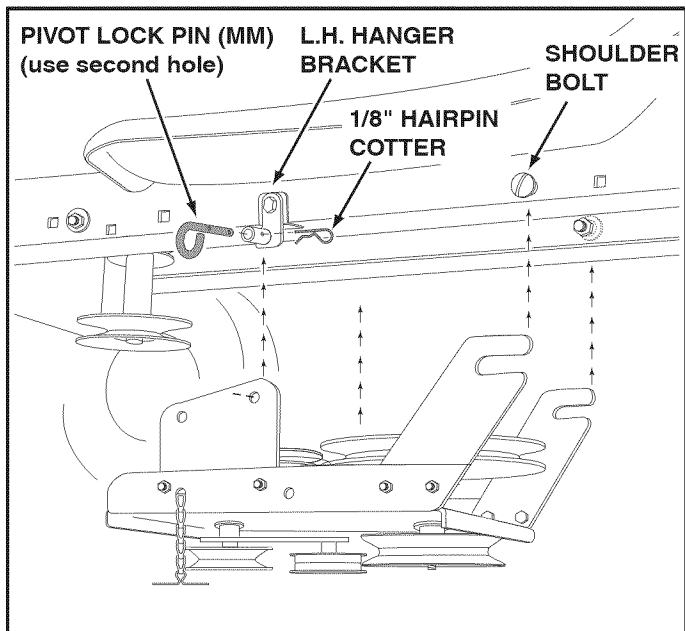

FIGURE 18 VIEWED FROM LEFT SIDE

STEP 20: (SEE FIGURE 19)

- Assemble the drive belt onto the engine pulley first and then onto the large pulley on top of the clutch/idler assembly. Place the belt to the inside of the idler pulley and the belt keeper bolt located beside the large pulley.
- Place tension on the belt by pulling the left side tensioning chain out as far as the 3/32" hairpin cotter in the chain will allow. Secure the chain in this position by inserting a 1/8" hairpin cotter through the chain.

IMPORTANT: Do Not assemble the drive belt around the outside of the keeper bolt beside the large pulley.

- Go to step 48 on page 22.

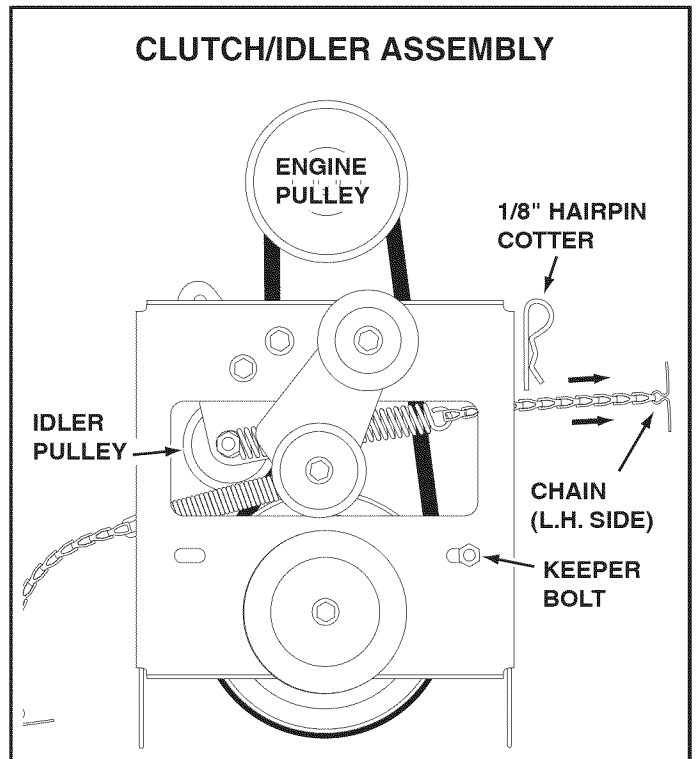

FIGURE 19 VIEWED FROM UNDERNEATH

INSTRUCTIONS FOR TRACTORS WITH DUAL FRONT DECK SUSPENSION BRACKETS

FASTEN SIDE PLATES TO TRACTOR

If your tractor resembles figure 20, go to step 21.
 If your tractor resembles figure 22, go to step 23.

STEP 21: (SEE FIGURE 20)

- Remove bolts from front three holes shown.
- If a bolt is present in the fourth hole, replace it with a 5/16" x 1" carriage bolt without a nut. The bracket fastened to inside of frame must remain in place.

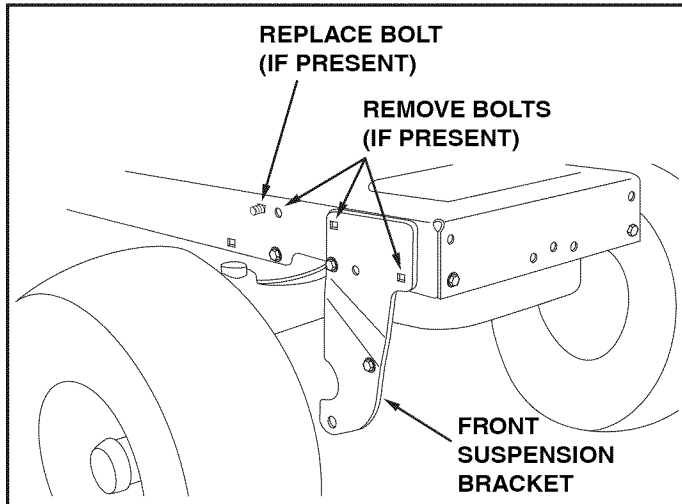

FIGURE 20 RIGHT SIDE VIEW

STEP 22: (SEE FIGURE 21)

- Fasten the R.H. Side Plate (bend facing out) to the front three holes shown in the tractor frame using three 3/8" x 1" thread forming bolts, three 3/8" lock washers and one 1/2" washer placed on the third bolt as a shim between the side plate and the frame. Tighten all bolts. Repeat for the L.H. side.

NOTE: If you installed a bolt in the fourth hole in step 21, assemble a 5/16" flange nut onto the bolt after the side plate is installed.

- Go to step 25 on this page.

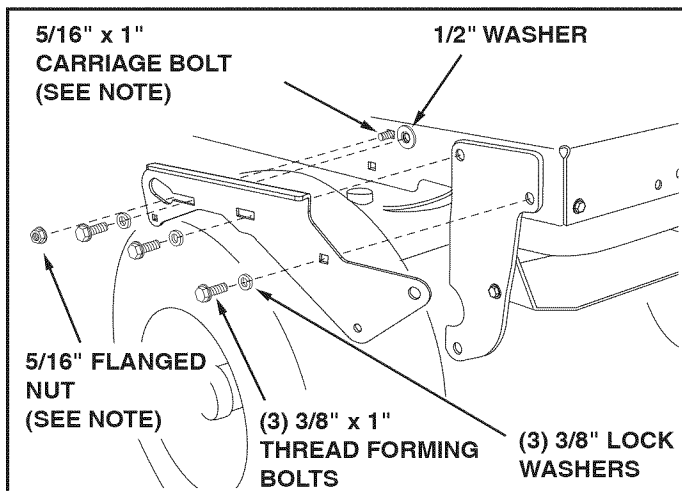

FIGURE 21 RIGHT SIDE VIEW

STEP 23: (SEE FIGURE 22)

- Remove any bolts found in the holes shown.

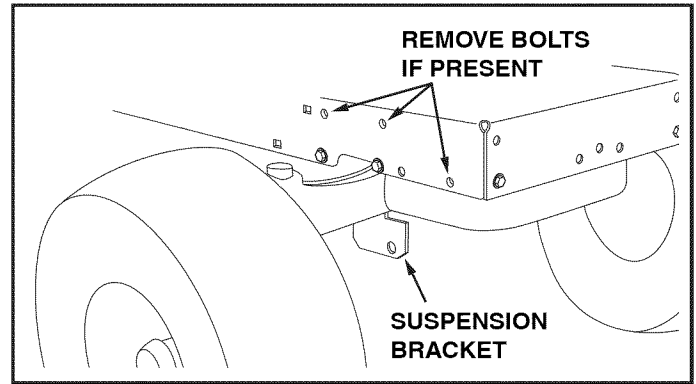

FIGURE 22 RIGHT SIDE VIEW

STEP 24: (SEE FIGURE 23)

- Fasten the R.H. Side Plate (bend facing out) to the three holes shown in the tractor frame. Use three 3/8" x 1" thread forming bolts, 1/2" washers and 3/8" lock washers. Tighten all bolts and repeat for the L.H. side.

NOTE: If the bolt inserts freely into the front hole, assemble a 3/8" flanged nut onto the bolt.

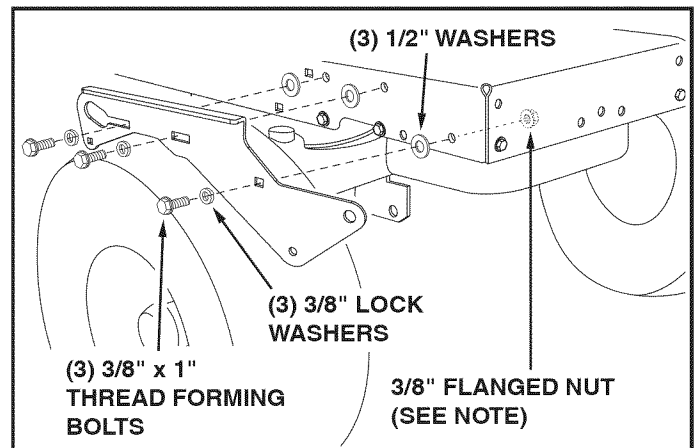

FIGURE 23 RIGHT SIDE VIEW

STEP 25: (SEE FIGURE 24)

- Assemble a shoulder bolt and a 3/8" washer to the outside of each side plate, securing them with a 3/8" flanged nut.

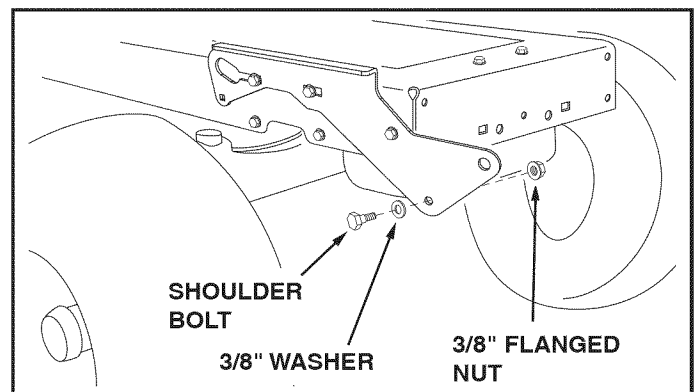

FIGURE 24 RIGHT SIDE VIEW

INSTALLING HANGER BRACKETS

For better clearance, lower the tractor's suspension arms using the attachment lift lever.

STEP 26: (SEE FIGURE 25 or 26)

On Tractors With Foot Rest Brackets

- Remove the bolt and nut that fasten the L.H. and R.H. foot rest brackets to the frame.
- Attach the L.H. Hanger Bracket (marked "L") to the inside of the tractor frame using two 3/8" x 1" carriage bolts and 3/8" flanged nuts. Bolt heads go on inside of tractor frame. Repeat for the R.H. side.

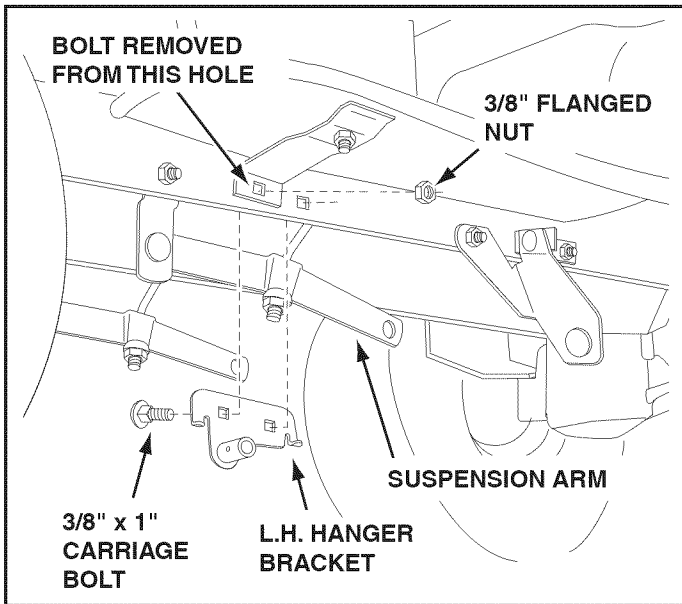

FIGURE 25 LEFT SIDE VIEW

On Tractors Without Foot Rest Brackets

- Find the empty hole beneath the foot rest. Attach the L.H. Hanger Bracket (marked "L") to the inside of the frame using a 3/8" x 1" carriage bolt and a 3/8" flanged nut. Bolt head goes on inside of tractor frame. Repeat for the R.H. side.

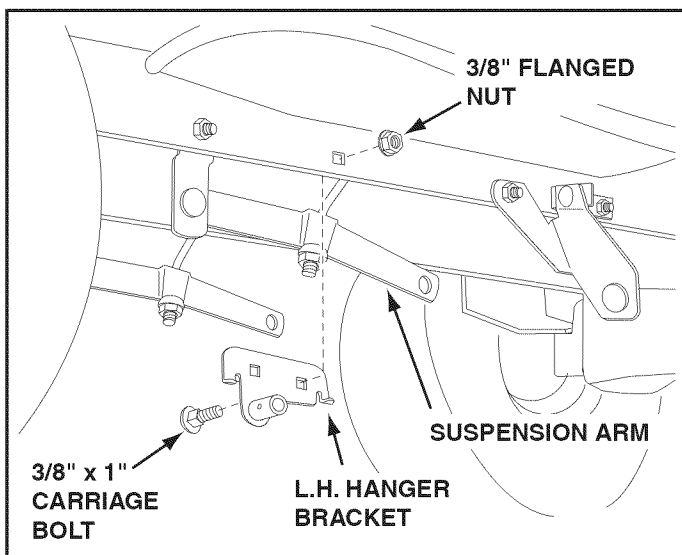

FIGURE 26 LEFT SIDE VIEW

INSTALLING SHOULDER BOLTS

STEP 27: (SEE FIGURE 27)

- Remove the bolt, washer and nut which fasten the sway bar bracket to the L.H. side of the tractor frame. Replace with a shoulder bolt and a 3/8" flanged nut. Bolt goes on inside of frame.

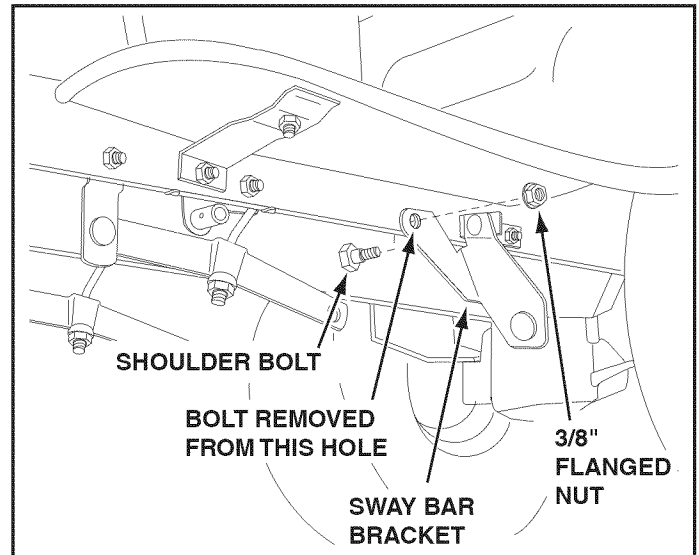

FIGURE 27 LEFT SIDE VIEW

STEP 28: (SEE FIGURE 28)

- Assemble a shoulder bolt and 3/8" flanged nut to the R.H. side of the tractor frame, using the first empty hole to the rear of the R.H. hanger bracket. Bolt goes on inside of frame.

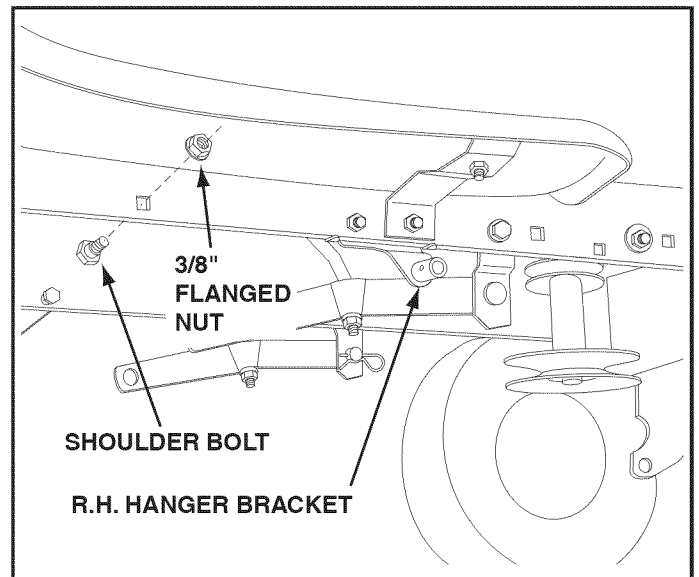

FIGURE 28 RIGHT SIDE VIEW

INSTALLING CLUTCH/IDLER ASSEMBLY

This section covers the installation of the Clutch/Idler assembly to tractors with attachment clutches that are either rod operated (p. 16), cable operated (p. 18) or electric (p. 20). Use the appropriate instructions for your tractor.

ROD OPERATED MANUAL ATTACHMENT CLUTCH

STEP 29: (SEE FIGURE 29)

- Move the attachment clutch lever on the dash panel to the disengaged (down) position.
- Screw the trunnion onto the end of the snow thrower engagement rod.
- Locate the clutch arm (where the mower clutch rod was connected) underneath the right hand side the tractor, just to the inside of the suspension arm. **If there is an extension** attached to the clutch lever, the extension, bolt and nut must be removed and stored with the mower deck.

IMPORTANT: Re-attach the extension to the clutch lever before reinstalling the mower deck.

- Position the engagement rod to the inside of the clutch arm and insert the drilled end of the rod through the arm. Secure with a 5/64" hairpin cotter.

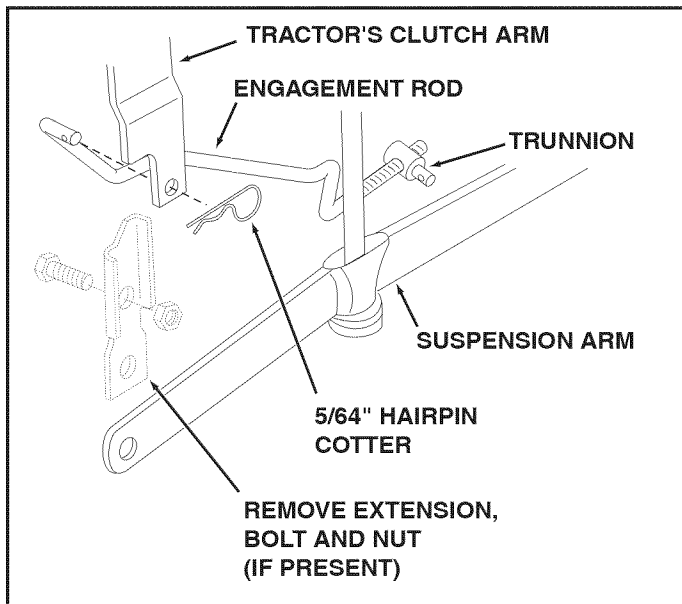

FIGURE 29

RIGHT SIDE VIEW

STEP 30: (SEE FIGURE 30)

- Attach the two rear pulley frame brackets to the inside of the clutch/idler assembly using two 5/16" x 1" hex bolts, eight 5/16" washers and two 5/16" nylock nuts for each bracket.

- Attach the two front pulley frame brackets to the inside of the clutch/idler assembly using two 5/16" x 3/4" hex bolts, 5/16" washers and 5/16" nylock nuts for each bracket. Add extra washers if needed.
- Insert a tensioning chain through the hole shown and attach the end link to the spring on the lower idler arm.

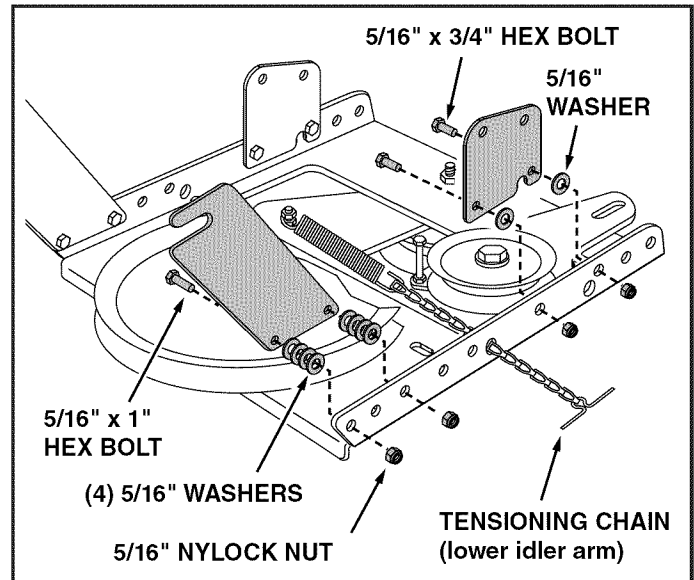

FIGURE 30

STEP 31: (SEE FIGURE 31)

- Three different length drive belts are included with your snow thrower. Tractors with manual attachment clutches and dual front deck suspension brackets use the 55" drive belt with #46989 printed on the outside of the belt. **DO NOT USE** the other belts.
- Slightly loosen the hex bolt next to the flat idler pulley. Install the drive belt down between the hex bolt and the flat idler pulley with the flat side of the belt against the pulley. Retighten the hex bolt.
- Loop the belt around the large v-pulley, placing it between the v-pulley and the hex bolt next to the pulley.

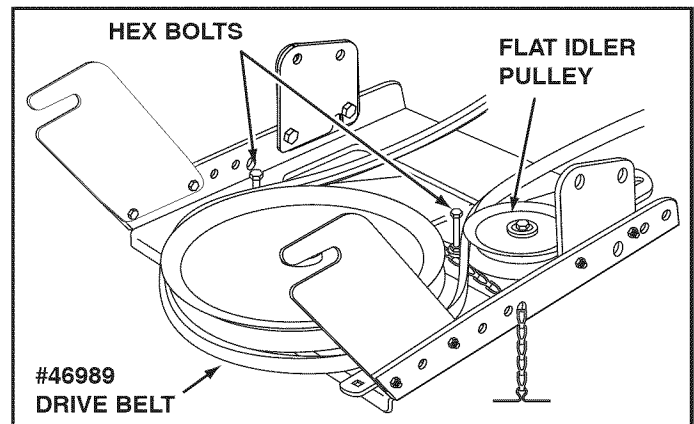

FIGURE 31



Did you choose the correct drive belt for your tractor? Using the wrong length belt may cause premature bearing or belt failure.

STEP 32: (SEE FIGURE 32)

- Be sure to lift up the front end of the engagement rod as shown when performing the next operation. You can temporarily support the rod using a rubber band tied to the engine pulley keeper.
- Attach the clutch/idler assembly to the tractor frame as follows. Hook the assembly's notched rear pulley frame brackets onto the two shoulder bolts you assembled to the inside of the tractor frame. Lift the front of the assembly and attach it to the R.H. and L.H. hanger brackets using two pivot lock pins and 1/8" hairpin cotters.

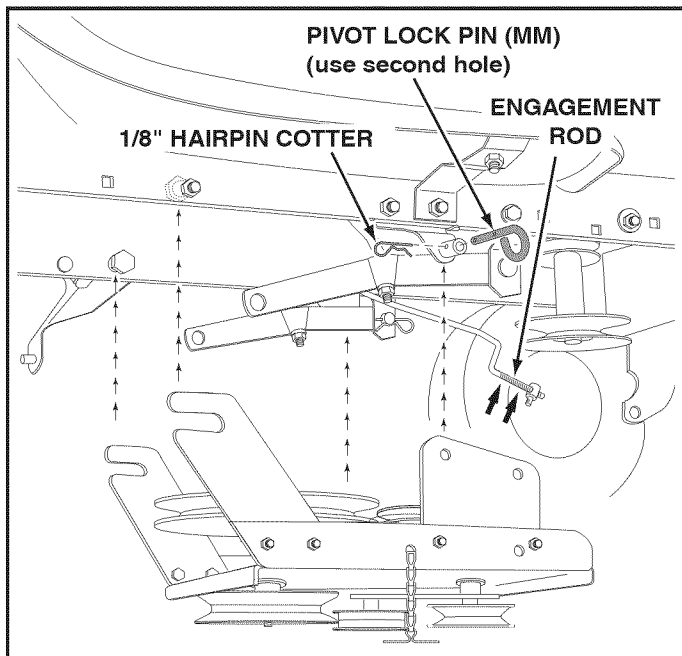

FIGURE 32 **RIGHT SIDE VIEW**

STEP 33: (SEE FIGURE 33)

- Make sure the attachment clutch lever on the dash panel is in the disengaged (down) position.
- Pivot the upper idler arm so that it rests against the stop bolt and is pointing toward the front as shown. Screw the trunnion along the threads of the engagement rod until it is aligned at the front end of the idler arm slot. Attach the trunnion to the slot using the 3/8" thin washer and a 5/64" hairpin cotter.
- Remove the engine pulley keeper from the side of the tractor frame by removing the washer and nut that secure the keeper. Attach the new pulley keeper supplied with the snow thrower, reusing the original bolt, washer and nut.

NOTE: Some tractors may already be equipped with a pulley keeper that is identical to the new one supplied.

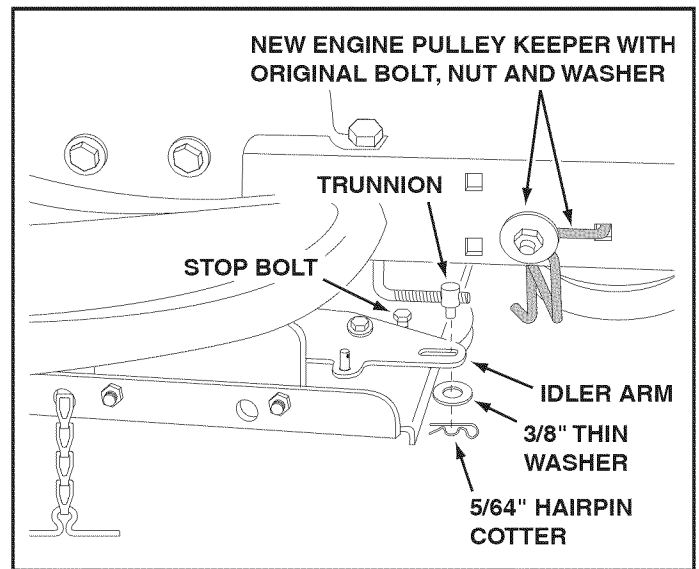

FIGURE 33 **RIGHT SIDE VIEW**

STEP 34: (SEE FIGURE 34)

- Assemble the short "V" belt onto the engine pulley and then onto the large pulley on top of the clutch/idler assembly. The belt must be placed to the inside of the engine pulley keeper, the idler pulley and the keeper bolt located beside the large pulley.

IMPORTANT: Do Not assemble the "V" belt around the outside of the engine pulley keeper or the keeper bolt.

- Go to step 48 on page 22.

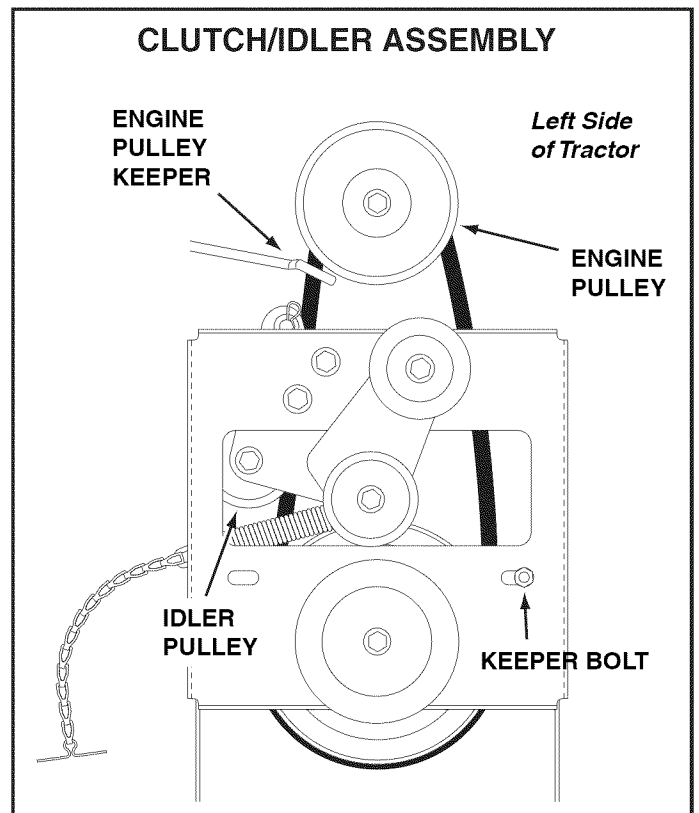

FIGURE 34 **VIEWED FROM UNDERNEATH**

CABLE OPERATED MANUAL ATTACHMENT CLUTCH

STEP 35: (SEE FIGURE 35)

- Assemble the cable bracket to the inner half of the double holes in the bottom of the clutch/idler assembly using two 5/16" x 3/4" carriage bolts and 5/16" nylock nuts. Use the front holes in the cable bracket if your tractor has a 42" mower deck. Use the rear holes if your tractor has a 46" mower deck.

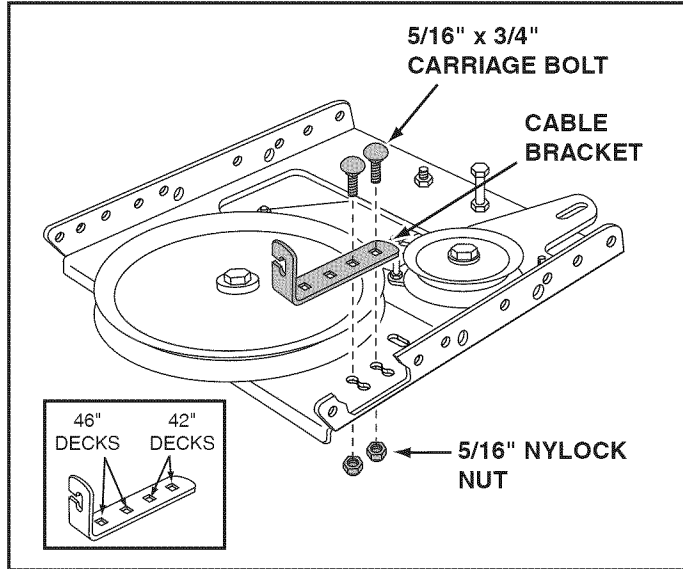

FIGURE 35

STEP 36: (SEE FIGURE 36)

- Attach the two rear pulley frame brackets to the inside of the clutch/idler assembly using two 5/16" x 1" hex bolts, eight 5/16" washers and two 5/16" nylock nuts for each bracket.
- Attach the two front pulley frame brackets to the inside of the clutch/idler assembly using two 5/16" x 3/4" hex bolts, 5/16" washers and 5/16" nylock nuts for each bracket. Add extra washers if needed in step 39.
- Insert a tensioning chain through the hole shown and attach the end link to the spring on the lower idler arm.

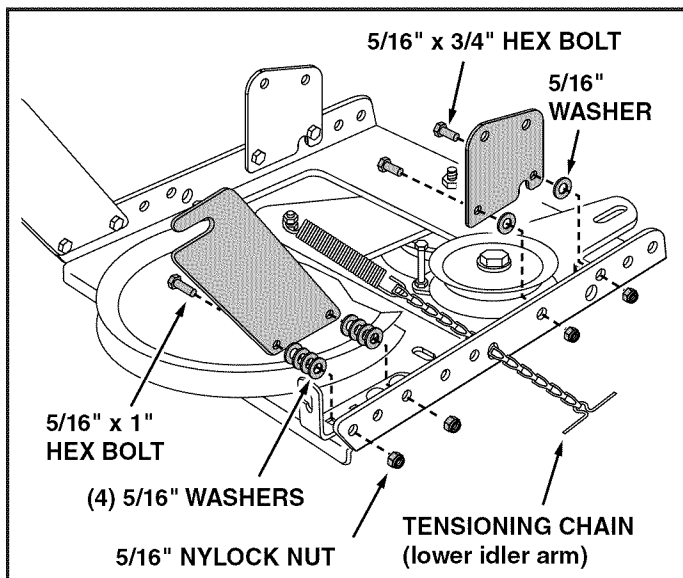

FIGURE 36

STEP 37: (SEE FIGURE 37)

- Three different length drive belts are included with your snow thrower. Tractors with manual attachment clutches and dual front deck suspension brackets use the 55" drive belt with #46989 printed on the outside of the belt. **DO NOT USE** the other belts.
- Slightly loosen the hex bolt next to the flat idler pulley. Install the drive belt down between the hex bolt and the flat idler pulley with the flat side of the belt against the pulley. Retighten the hex bolt.
- Loop the belt around the large v-pulley, placing it between the v-pulley and the hex bolt next to the pulley.

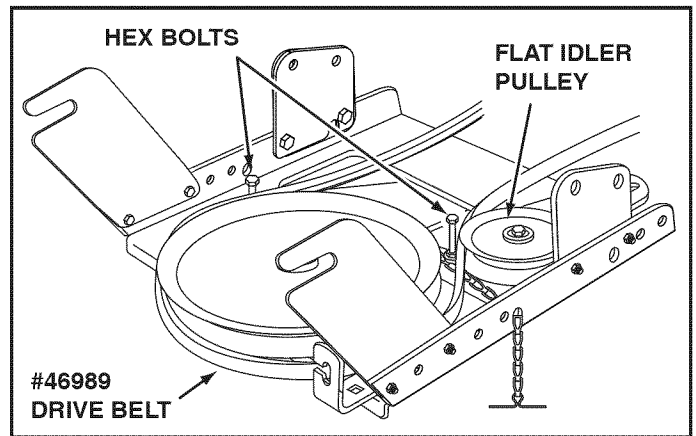

FIGURE 37



Did you choose the correct drive belt for your tractor? Using the wrong length belt may cause premature bearing or belt failure.

STEP 38: (SEE FIGURE 38)

- Move the attachment clutch lever on the dash panel to the disengaged (down) position.
- Place the clutch/idler assembly on the floor on the right side of the tractor.
- Attach the tractor's clutch cable to the cable bracket. Secure the cable housing guide (groove down) to the cable bracket using the original collar and a 5/64" hair cotter pin.
- Place a spacer on the welded pin on the idler arm. Hook the end of the clutch spring over the pin and secure it with a 1/4" washer and a 5/64" hair cotter pin.

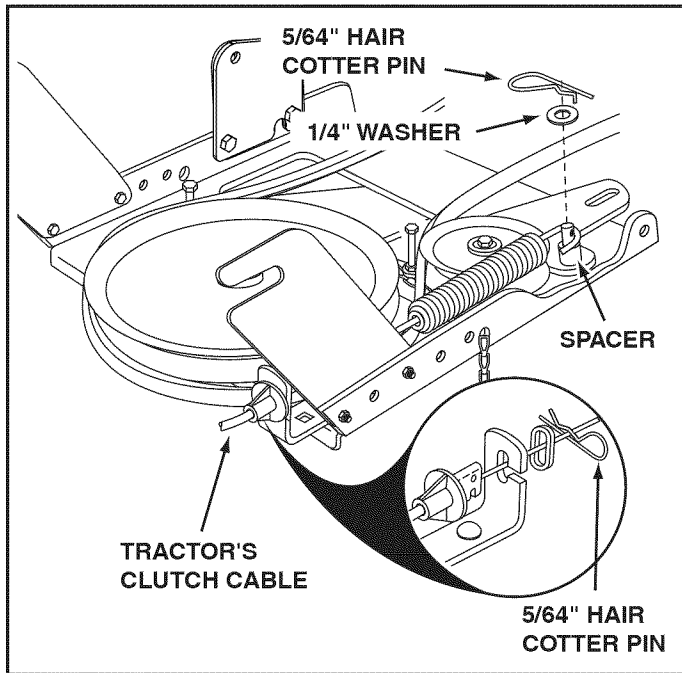

FIGURE 38

STEP 39: (SEE FIGURE 39)

- Remove the engine pulley keeper from the side of the tractor frame by removing the washer and nut that secure the keeper. Attach the new pulley keeper supplied with the snow thrower, reusing the original bolt, washer and nut.

NOTE: Some tractors may already be equipped with a pulley keeper that is identical to the new one supplied.

- Attach the clutch/idler assembly to the tractor frame as follows. Hook the assembly's notched pulley frame brackets onto the two shoulder bolts you assembled to the inside of the tractor frame. Lift the front of the assembly and attach it to the R.H. and L.H. hanger brackets using two pivot lock pins and 1/8" hairpin cotters.

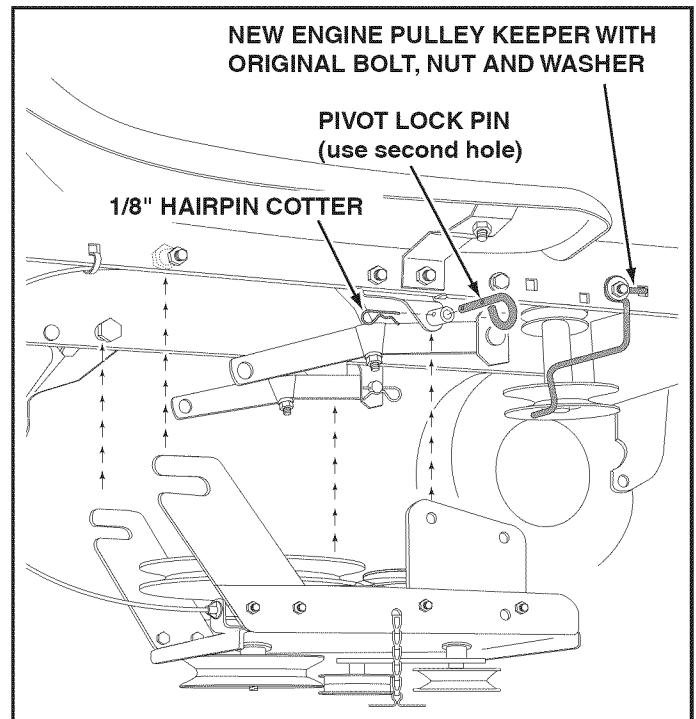

FIGURE 39

STEP 40: (SEE FIGURE 40)

- Assemble the short "V" belt onto the engine pulley and then onto the large pulley on top of the clutch/idler assembly. The belt must be placed to the inside of the engine pulley keeper, the idler pulley and the keeper bolt located beside the large pulley.

IMPORTANT: Do Not assemble the "V" belt around the outside of the engine pulley keeper or the keeper bolt.

- Go to step 48 on page 22.

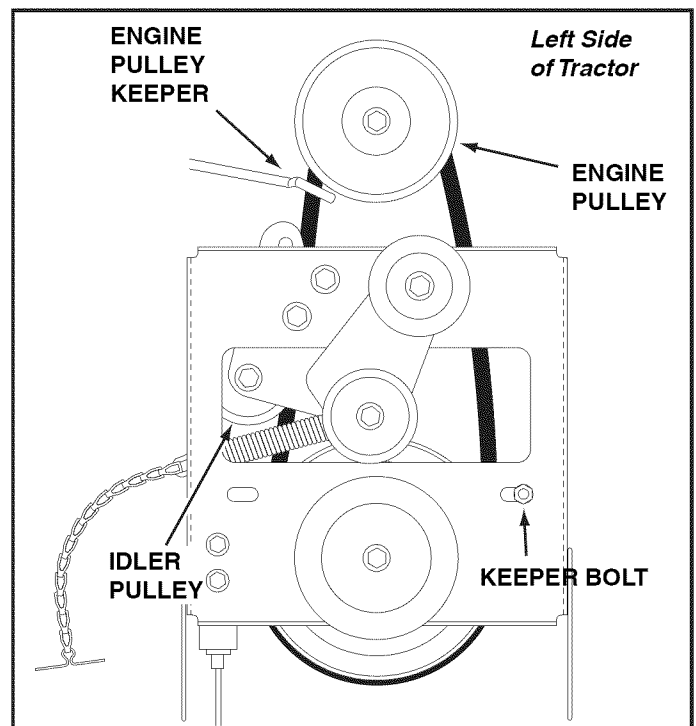

FIGURE 40

VIEWED FROM UNDERNEATH

ELECTRIC ATTACHMENT CLUTCHES

STEP 41: (SEE FIGURE 41)

- Turn the clutch idler assembly upside down.
- Hook the spring (onto the end of the bolt that extends through the nut on the bottom of the upper idler arm. Install a 3/8" hex lock nut onto the bolt, leaving enough space for the spring to pivot.

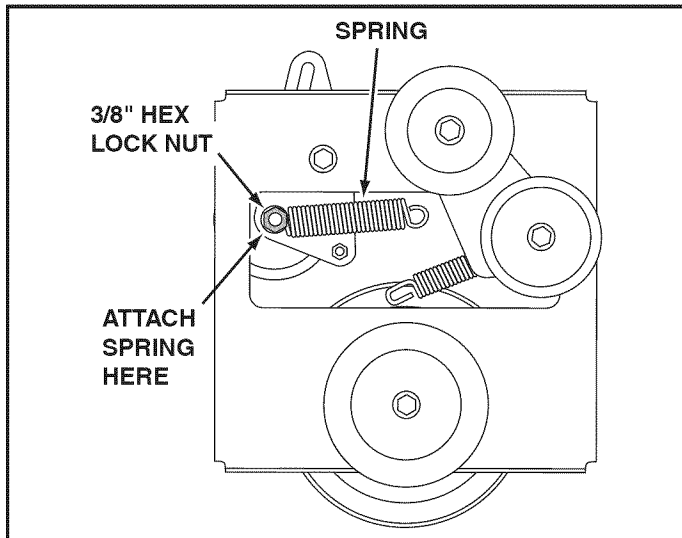

FIGURE 41

BOTTOM VIEW

STEP 42: (SEE FIGURE 42)

- Insert tensioning chains through the holes shown and attach to the springs on the upper and lower idler arms.
- Attach a 3/32" hairpin cotter to the chain attached to the upper idler arm, placing it in the fifth link from the spring.

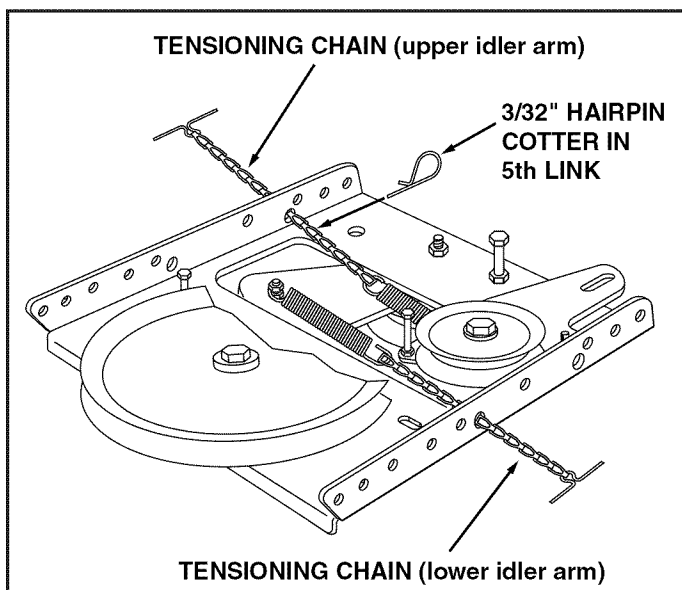

FIGURE 42

STEP 43: (SEE FIGURE 43)

- Attach the two rear pulley frame brackets to the inside of the clutch/idler assembly using two 5/16" x 1" hex bolts, eight 5/16" washers and two 5/16" nylock nuts for each bracket.
- Attach the two front pulley frame brackets to the inside of the clutch/idler assembly using two 5/16" x 3/4" hex bolts, 5/16" washers and 5/16" nylock nuts for each bracket.

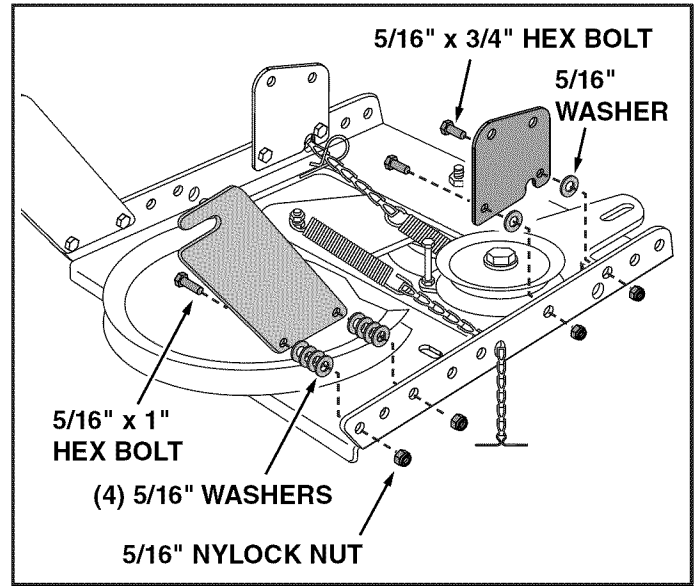

FIGURE 43

STEP 44: (SEE TABLE 2)

- Three different length drive belts are included with your snow thrower. Select one of the two belts listed below that is correct for your tractor. The part number is printed on the outside of the belt.
- Set aside the belts that are not for your tractor, to avoid accidentally using them.

55" BELT (PART #46989)		
TRACTOR TYPE	DECK SIZE	CLUTCH TYPE
(LT) Lawn Tractor	38", 42", 46"	Electric
56" BELT (PART #48138)		
TRACTOR TYPE	DECK SIZE	CLUTCH TYPE
(LT) Lawn Tractor	48"	Electric

TABLE 2

STEP 45: (SEE FIGURE 44)

- Turn the clutch/idler assembly right side up.
- Slightly loosen the hex bolt next to the flat idler pulley. Install the drive belt down between the hex bolt and the flat idler pulley with the flat side of the belt against the pulley. Retighten the hex bolt.
- Loop the belt around the large v-pulley, placing it between the v-pulley and the hex bolt next to the pulley.

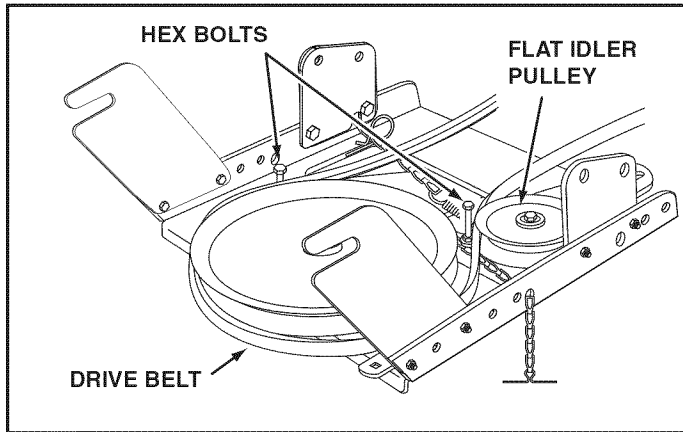

FIGURE 44

STOP Did you choose the correct drive belt for your tractor? Using the wrong length belt may cause premature bearing or belt failure.

STEP 46: (SEE FIGURE 45)

- Attach the clutch/idler assembly to the tractor frame as follows. Hook the assembly's notched rear pulley frame brackets onto the two shoulder bolts you assembled to the inside of the tractor frame. Lift the front of the assembly and attach it to the R.H. and L.H. hanger brackets using two pivot lock pins and 1/8" hairpin cotter pins.

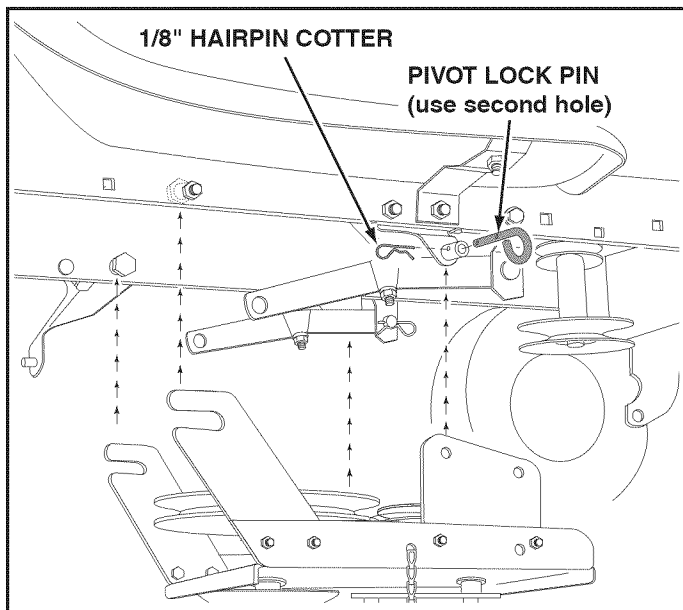

FIGURE 45

RIGHT SIDE VIEW

STEP 47: (SEE FIGURE 46)

- Assemble the drive belt onto the engine pulley and then onto the large pulley on top of the clutch/idler assembly. The belt must be placed to the inside of the idler pulley and the keeper bolt located beside the large pulley.
- Place tension on the belt by pulling the left side tensioning chain out as far as the 3/32" hairpin cotter will allow. Secure the chain in this position by inserting a 1/8" hairpin cotter through the chain.

IMPORTANT: Do Not assemble the "V" belt around the outside of the engine pulley keeper or the keeper bolt.

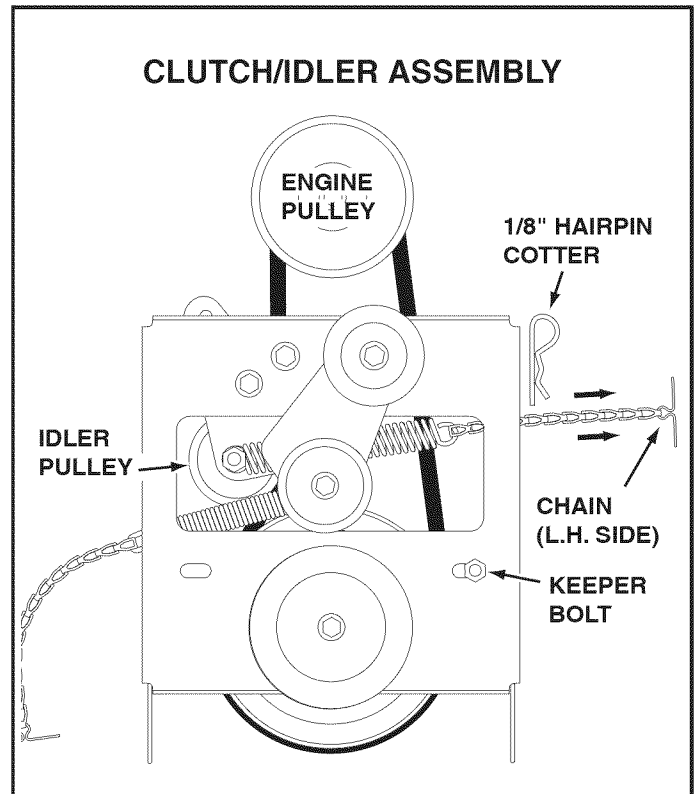

FIGURE 46

VIEWED FROM UNDERNEATH

ASSEMBLY OF THE SNOW THROWER

STEP 48: (SEE FIGURE 47)

- Place the lift handle into the lift bracket on the right side of the snow thrower. Fasten the handle to the bracket using two 5/16" x 1-3/4" hex bolts and 5/16" Nylock nuts.

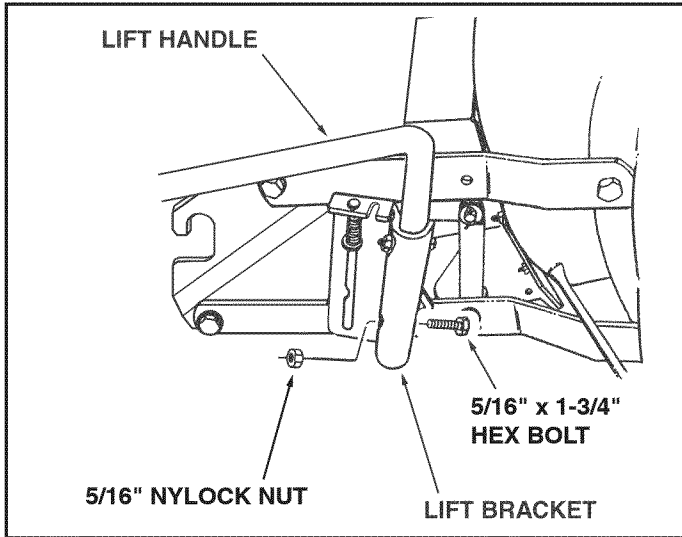

FIGURE 47 RIGHT SIDE VIEW

NOTE: Be sure the lift release cable's plastic covering stays inserted into the trigger assembly for the next step.

STEP 49: (SEE FIGURE 48)

- Push the lift handle down into the locked position. Insert the end of the cable wire into the hole in the lift rod. Place the threaded fitting into the slot in the lift bracket, with one hex nut above and one hex nut and the lock washer below the slot. Tighten the nuts, adjusting them to eliminate slack in the cable wire. Refer also to the Service and Adjustments section on page 28 in this manual.

HINT: For easier assembly of the lift release cable, tilt the snow thrower forward onto the spiral auger.

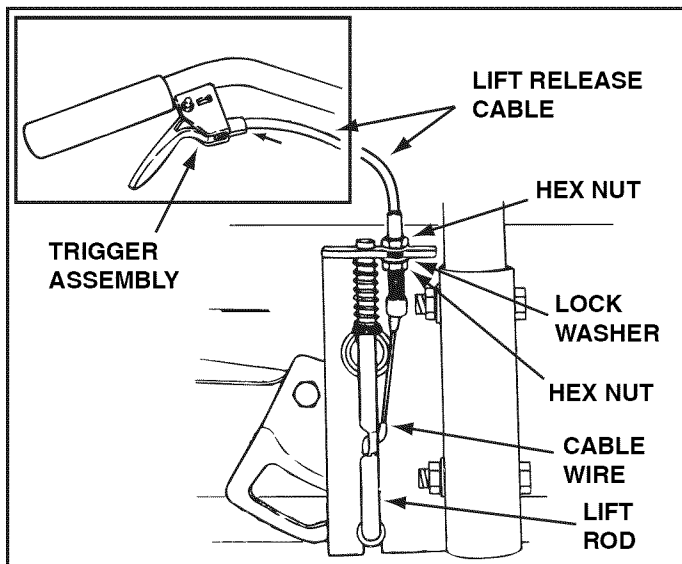

FIGURE 48 RIGHT SIDE VIEW

STEP 50: (SEE FIGURE 49)

- Tilt the snow thrower back down to the ground.
- Remove the nylon tie which fastens the auger drive belt to the discharge housing, leaving the belt assembled around the pulleys.
- Remove the nylon tie which fastens the chute crank rod to the crank rod support tube.
- Assemble the crank rod support tube to the bracket on the left side of the discharge housing using two 5/16" x 1-1/4" carriage bolts, and 5/16" Nylock nuts.

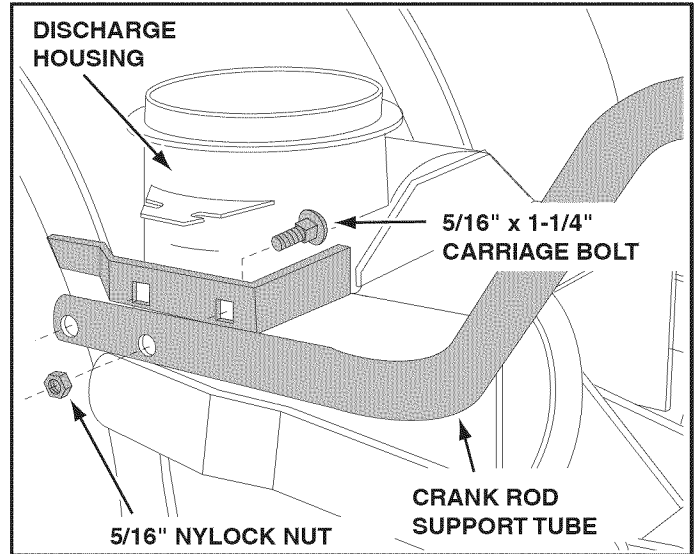

FIGURE 49 LEFT SIDE VIEW

STEP 51: (SEE FIGURE 50)

- Attach the chute tilt control assembly to the top side of the crank support tube using two 5/16" x 1-3/4" carriage bolts, bowed washers and 5/16" Nylock nuts.

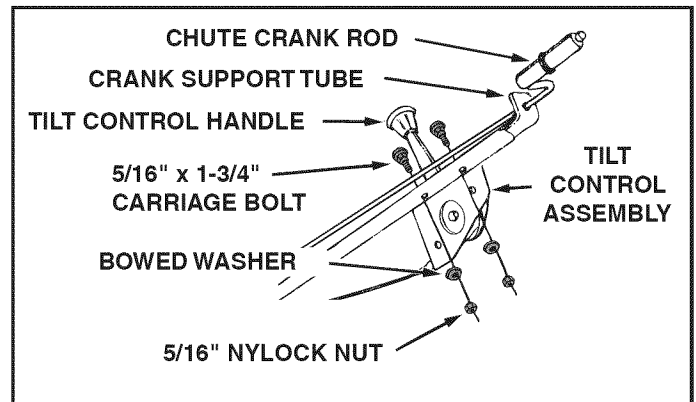

FIGURE 50 LEFT SIDE VIEW

STEP 52: (SEE FIGURE 51)

- Attach the chute crank rod assembly brackets to the plastic bracket on the left side of the discharge housing. Align the chute crank bracket beneath the rod support bracket and assemble both to the plastic bracket using two 5/16" x 1" carriage bolts, 5/16" washers and 5/16" Nylock nuts. **Do not tighten yet.**

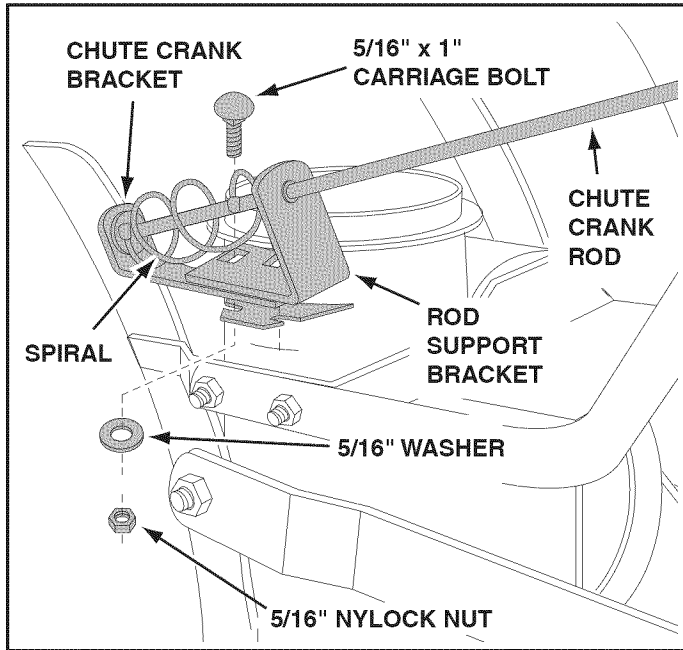

FIGURE 51 LEFT SIDE VIEW

STEP 53: (SEE FIGURE 52)

- Coat the top of the ring around the discharge opening with general purpose grease.
- Place the discharge chute (facing forward) onto the ring. Place the anti-rotation bracket on top of the chute flange, aligning it with the holes on the right hand side of the flange. Attach the three chute keepers (right side up as shown) to the bottom of the flange using six 1/4" x 1" hex bolts, 1/4" flat washers and 1/4" flanged lock nuts. **Tighten carefully** so that the nuts are snug but do not dig into the plastic chute keepers.
- Place the plastic cap onto the short end of the anti-rotation bracket.
- Position the crank rod spiral (see figure 51) so that it does not rub against the bottoms of the notches in the chute flange. **Tighten** the nuts.
- Check if the crank rod rotates the chute freely. If not, loosen by 1/4 turn each of the six hex bolts holding the chute keepers to the chute flange.
- Secure the control cables to the crank rod support tube using a nylon tie.

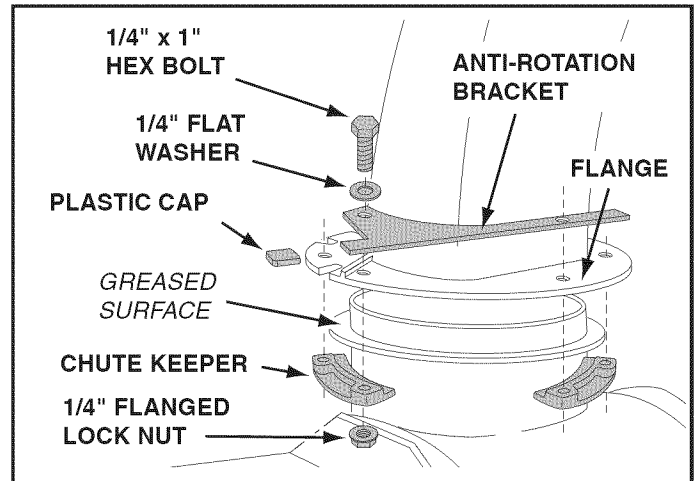

FIGURE 52 RIGHT SIDE VIEW

STEP 54: (SEE FIGURE 53)

Skip this step if you have a lawn tractor.

This step is for garden tractors only.

- If you have a (GT) Garden Tractor, remove the stop bolts from each side of the snow thrower frame.

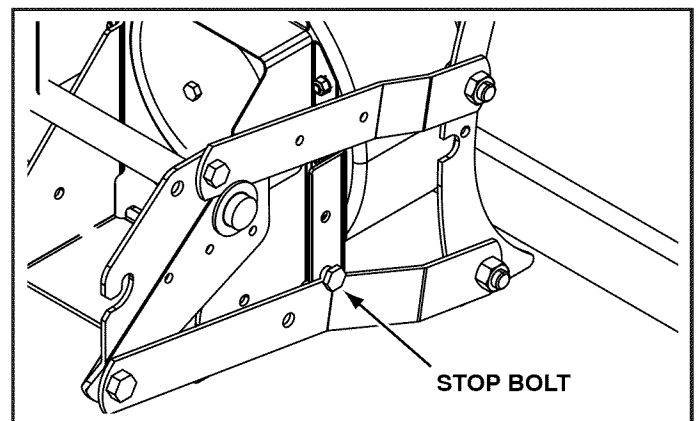

FIGURE 53 RIGHT SIDE VIEW

ATTACHING SNOW THROWER TO TRACTOR

NOTE: An additional person's help may be required to mount the snow thrower to the front of the tractor.

STEP 55: (SEE FIGURE 54)

- Place the tractor and snow thrower on a flat, level surface so that the tractor can be rolled forward to attach the snow thrower.
- Remove the Attachment Pin from the snow thrower.
- Extend the auger belt out behind the snow thrower, making sure the belt is still looped over the top of the large drive pulley and underneath the two idler pulleys. The "V" side of the belt must be seated in the grooves of all three pulleys.
- Roll the tractor up behind the snow thrower, centering it between the snow thrower's mounting plates.
- Raise the rear of the snow thrower by lifting up on the lift handle until the notches in the mounting plates align with the shoulder bolts in the tractor's side plates. Guide the bolts into the notches.
- To ease the assembly of the auger drive belt, delay the installation of the attachment pin until you have assembled the belt as instructed in steps 56 and 57.

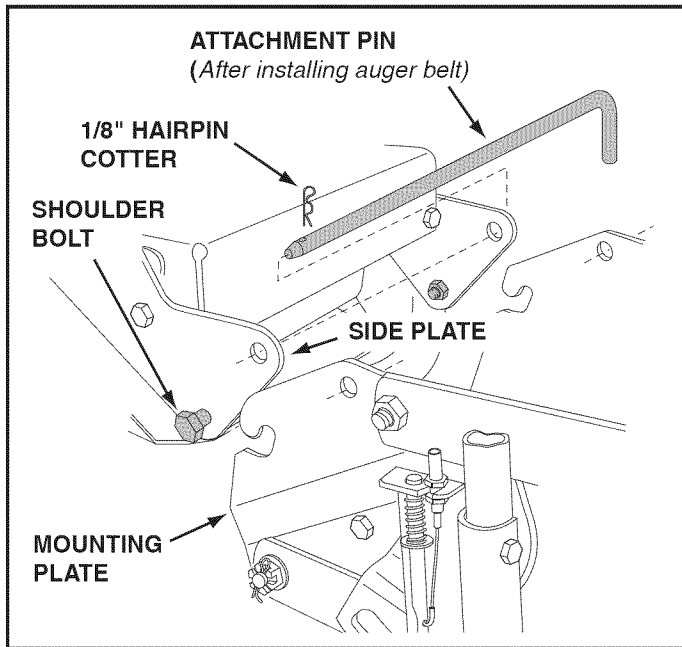

FIGURE 54

RIGHT SIDE VIEW

BEFORE INSTALLING THE AUGER BELT

STEP 56: (SEE FIGURE 55)

- The auger belt comes pre-assembled to the pulleys on the snow thrower housing. Make sure the belt passes over the top of the auger pulley and then twists 1/4 turn to pass underneath each side idler pulley. The "V" side of the belt must mate with the grooves of the pulleys.

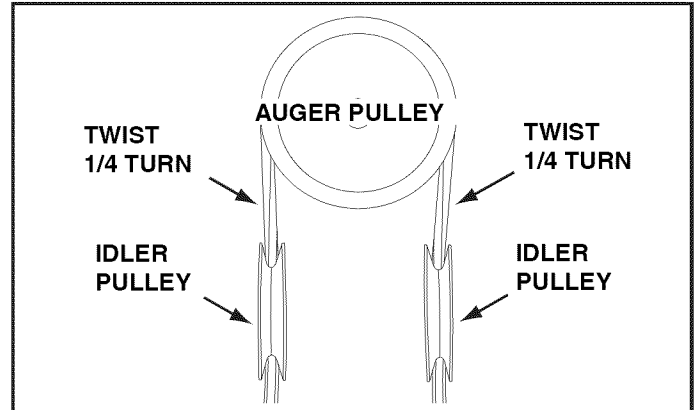

FIGURE 55

INSTALLING THE AUGER BELT

STEP 57: (SEE FIGURE 56)

- Push the lift handle down to increase slack in the belt (attachment pin must first be removed).
- Swing the idler arm over to the left side.
- Place the auger belt around the rear pulley and between the two pulleys on the idler arm. The "V" side of the belt must be seated in the grooves of the V-pulleys.

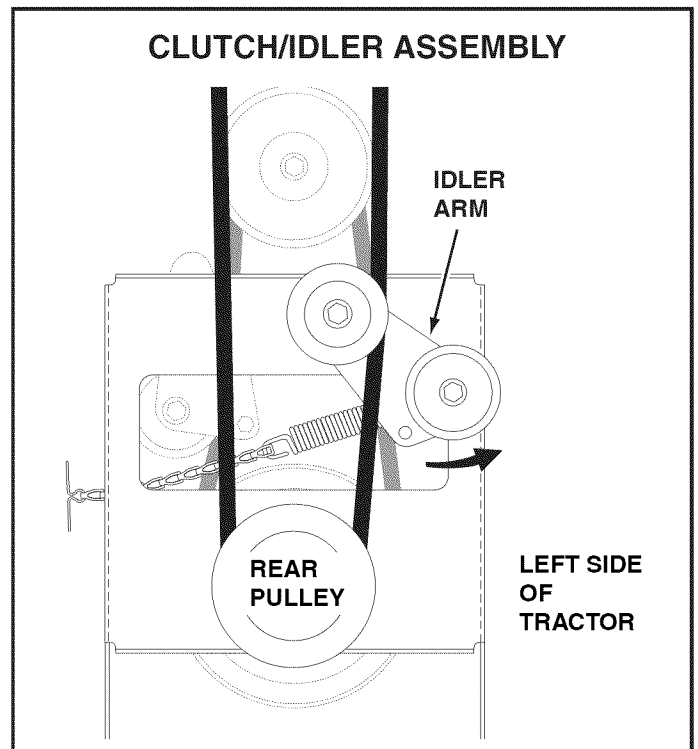

FIGURE 56

VIEWED FROM UNDERNEATH

INSTALLING THE ATTACHMENT PIN

STEP 58: (REFER BACK TO FIGURE 54 ON PAGE 24)

- Lift the front of the snow blower to align the holes in the mounting plates and the side plates. From the left side of the tractor insert the attachment pin through the holes. Secure it with by reinstalling the 1/8" hairpin cotter.

SETTING THE AUGER BELT TENSION

STEP 59: (SEE FIGURE 57)

- Pull the tensioning chain until the end of the spring is pulled through the hole in the side of the Clutch/Idler assembly. Install a 1/8" hairpin cotter through the end of the spring, securing it on the outside of the Clutch/Idler assembly.

IMPORTANT: For correct belt tension, the 1/8" hairpin cotter must attach to the end of the spring, not to the chain.

NOTE; To prevent the chain from dragging on the ground, loop the end of the chain through the pivot lock pin. Refer to figure 45 on page 21.

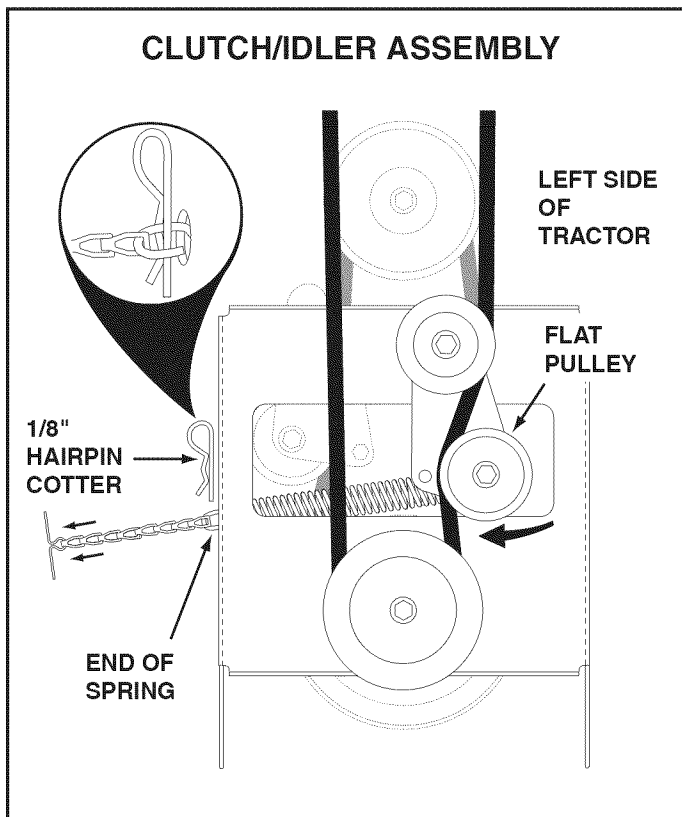

FIGURE 57

VIEWED FROM UNDERNEATH

ATTACH REFLECTORS TO REAR FENDER

STEP 60: (SEE FIGURE 58)

- If your tractor is not equipped with rear reflectors, assemble the supplied rear reflectors to the rear fender. Place the reflectors as close to the bottom of the fender and as far apart as the shape of the fender will allow.

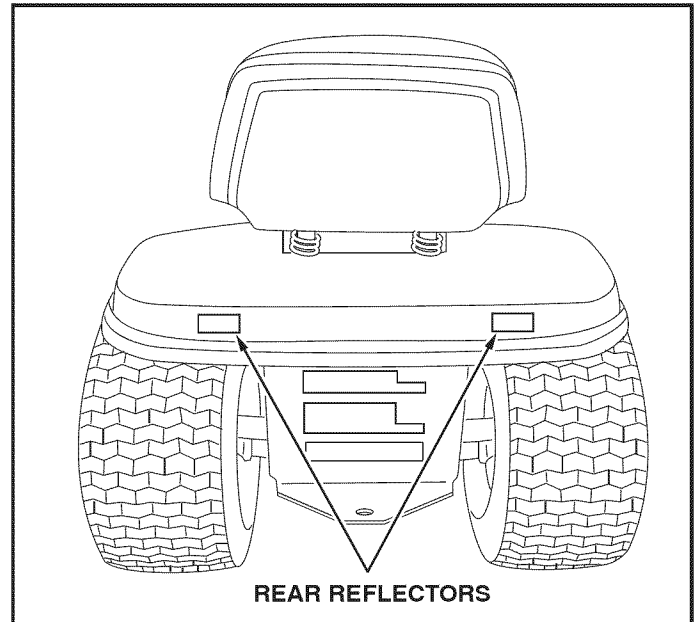

FIGURE 58

CHECKLIST

Before you operate your snow thrower, please review the following checklist to help ensure that you will obtain the best performance from your snow thrower.

- Make sure all assembly instructions have been completed with all bolts and nuts properly tightened.
- Make sure the correct drive belt was installed.
- Make sure the drive belt and auger belt are routed properly around pulleys and inside all belt keepers.
- Check discharge chute for proper rotation.
- Check operation of tilt control for upper chute.
- Verify that the lift handle will lock into and release from the raised transport position. (Refer to the Service and Adjustments section.)
- Check skid shoe adjustment. (Refer to the Service and Adjustments section.)

The following additional items are available from Sears to help enhance the performance of your snow thrower. See Accessories and Attachments on page 2.

- Tire chains which can be installed to improve traction.
- Rear wheel weights which can be installed in addition to the rear weight tray to improve traction.
- Snow Cab which can be installed to help protect against wind and blowing snow.

OPERATION

KNOW YOUR SNOW THROWER

Read this owner's manual and safety rules before operating your snow thrower.

Compare the illustration below with your snow thrower to familiarize yourself with the various controls and their locations.

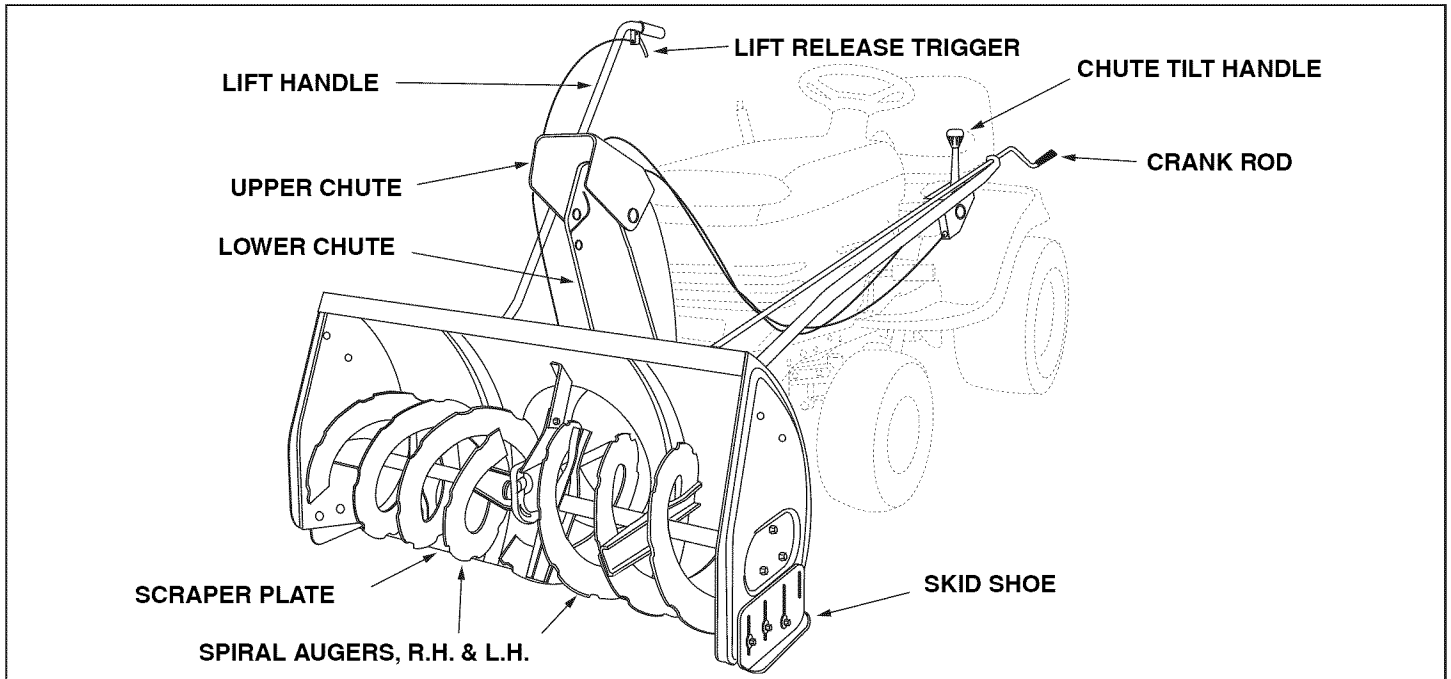

CHUTE TILT HANDLE Pivots the Upper Chute up or down to control the angle and distance of discharge.

CRANK ROD Rotates the Lower and Upper Chutes to control the direction of discharge.

LIFT HANDLE Used to lift or lower the snow thrower to transport or operating position.

LIFT RELEASE TRIGGER Releases the lock which holds the snow thrower in the transport position

UPPER AND LOWER DISCHARGE CHUTE Controls direction and height of snow discharge.

SCRAPER PLATE Replaceable plate that absorbs wear and impact from contact with ground.

SKID SHOE Controls amount of clearance between the scraper plate and the ground.

SPIRAL AUGER, R.H. & L.H. Feed snow to the impeller fan at the center of the housing.

BEFORE STARTING

- Use the end of assembly checklist to verify that all instructions have been properly completed.
- Make sure the skid shoes are adjusted to maintain adequate ground clearance between the snow thrower and the type of surface to be cleared. (Refer to the Service and Adjustments section.)
- Make sure the tractor engine has the correct oil for winter operation (SAE 5W-30). Refer to tractor owner's manual.

HOW TO START YOUR SNOW THROWER

- The tractor should be sitting with the engine running at full throttle. Move the attachment clutch to the engaged position, starting the snow thrower before the tractor clutch is engaged.

HOW TO STOP YOUR SNOW THROWER

- To stop the snow thrower, disengage the tractor's attachment clutch lever for manual clutches or the clutch switch for electric clutches. Refer to your tractor owner's manual.

HOW TO USE YOUR SNOW THROWER



CAUTION: Never direct discharge towards bystanders or windows. Do not allow anyone in front of unit.

CONTROLLING SNOW DISCHARGE

- To control the direction snow is thrown, the discharge chute has 180 degrees of rotation. Turn the crank rod to rotate the chute to the right or the left.
- To control the distance snow is thrown, the upper section of the discharge chute pivots up and down. Push forward on the chute tilt handle to pivot the chute down, decreasing the distance snow is thrown. Pull back on the handle to pivot the chute up, increasing the distance snow is thrown.

RAISING AND LOWERING

- To raise, push down on the lift handle until the snow thrower locks in the raised transport position.
- To lower, push down slightly on the lift handle and pull the trigger. With the trigger pulled, slowly lower the snow thrower until it reaches the ground.



CAUTION: Do not operate the snow thrower without rear wheel weights attached to the tractor to provide extra traction and stability.

REMOVING SNOW

Snow removal conditions vary greatly from light fluffy snowfall to wet heavy snow. Operating instructions must be flexible to fit the conditions encountered. The operator must adapt the lawn tractor and snow thrower to depth of snow, wind direction, temperature and surface conditions.

- Before beginning operation, thoroughly inspect the area of operation and remove all door mats, sleds, boards, wires and other foreign objects.
- The spiral auger speed is directly related to engine speed. For maximum snow removal and discharge, maintain high engine r.p.m. (full throttle). It is advisable to operate the lawn tractor at a slow ground speed (1st gear) for safe and efficient snow removal.
- In deep, drifted or banked snow it will be necessary to use full throttle and a slow ground speed (1st gear). Drive forward into the snow, depress the tractor's clutch-brake pedal and allow the spiral auger to clear the snow. Repeat this method until a path is cleared. On the second pass, overlap the first enough to allow the snow thrower to handle the snow without repeated stopping and starting of forward motion.

- In extremely deep snow, raise the snow thrower from the ground to remove the top layer and drive forward only until the tractor's front tires reach the uncleared bottom layer of snow. Depress the tractor's clutch-brake pedal and allow the spiral auger to clear the snow. Reverse the tractor and lower the snow thrower to the ground. Drive the tractor forward until the snow again becomes too deep. Repeating this process into and out of drifts will eventually clear even the deepest of snow piles.
- If the snow thrower becomes clogged with snow or jammed with a foreign object, disengage the snow thrower immediately and shut off the tractor engine. Unclog the snow thrower before resuming operation.



DANGER: Shut off engine and disengage snow thrower before unclogging discharge chute. Unclog using a wooden stick, not your hands.

OPERATING TIPS

- Discharge snow down wind whenever possible.
- To help prevent snow from sticking to the snow thrower, allow the snow thrower to reach outdoor temperature before using it. A light coat of wax may also be applied to the inside surface of the snow thrower housing and discharge chute.
- Use tire chains to improve traction.
- Use rear wheel weights to improve traction.
- Before the first snowfall, remove all stones, sticks and other objects which could become hidden by the snow. Permanent obstacles should be marked for visibility.
- Overlap each pass slightly to assure complete snow removal.

MAINTENANCE

CUSTOMER RESPONSIBILITIES

- Read and follow the maintenance schedule and the maintenance procedures listed in this section.

MAINTENANCE SCHEDULE Fill in dates as you complete regular service.	Service Dates											
	Before each use	After each use	Every season	Before storage								
Check for loose fasteners	X											
Check scraper and shoes for wear	X			X								
Cleaning				X								
Lubrication Section			X									

LUBRICATION

- Oil all pivot points on the snow thrower.
- Oil the pivot points of the two idler arms on the clutch/idler assembly.
- Apply penetrating oil to the control cables of the discharge chute.
- Apply a good grade of spray lubricant to the trigger assembly and the chute tilt control assembly.

CHECK SCRAPER AND SHOES FOR WEAR

(Refer to figures 59 and 60 on page 28.)

- The scraper plate and skid shoes on the bottom of the snow thrower are subject to wear. To prevent damage to the spiral auger housing, replace plate and shoes before wear is excessive.

SERVICE AND ADJUSTMENTS



CAUTION: Before servicing or adjusting the snow thrower, shut off the engine, remove the spark plug wire(s), set the parking brake and remove the key from the tractor ignition.

REPLACING AUGER BELT

- Disengage the tractor's attachment clutch.
- Lower the snow thrower to the ground.
- Remove the attachment pin.
- Lock the snow thrower's lift handle in the down position to decrease belt tension.
- Release the spring tension from the auger belt idler arm on the bottom of the clutch/idler assembly.
- Remove the auger drive belt from the clutch/idler assembly and from the spiral auger housing.
- Install new belt over top of large auger drive pulley and under the two side idler pulleys. Twist the belt 1/4 turn to seat the "V" of the belt in the groove of each idler pulley. Refer to figure 55 on page 24.
- Assemble the belt onto the clutch/idler assembly.

SKID SHOE ADJUSTMENT

- The skid shoes are mounted on each side of the spiral auger housing. They regulate the distance the scraper plate is raised above the plowing surface. When removing snow from a gravel driveway or an uneven surface, it is advisable to keep the scraper plate as high above the surface as possible to prevent possible damage to the spiral auger. On blacktop or concrete surface, keep the scraper plate as close to the surface as possible.
- Raise the snow thrower off the ground and place a block under each end of the scraper plate. Loosen the six hex nuts securing the skid shoes to the housing. Adjust the skid shoes up or down and retighten the nuts securely. Adjust both skid shoes to the same height to keep the housing and the scraper plate level. See figure 59.

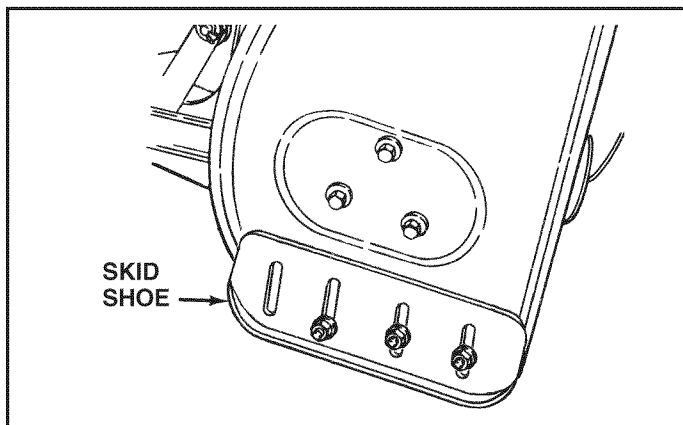

FIGURE 59

LIFT RELEASE CABLE ADJUSTMENT

- If the lift rod does not lock the snow thrower securely in the transport position, loosen the upper hex nut on the lift bracket a few turns and tighten the lower hex nut. Refer to figure 48 on page 22.
- If the lift rod fails to unlock completely to lower the snow thrower, loosen the lower hex nut on the lift bracket a few turns and tighten the upper hex nut. Refer to figure 48 on page 22.

CLUTCH DISENGAGEMENT ADJUSTMENT (For tractors with engagement rod clutches only. Not for electric clutches or cable clutches)

If the spiral auger on the snow thrower does not stop when the attachment clutch lever on the tractor is disengaged, then adjustment is necessary. Proceed as follows. Refer back to figure 33 on page 17.

- Place the attachment clutch lever in the disengaged position.
 - Remove the hairpin cotter from the engagement rod trunnion and lift the trunnion out of the hole in the idler arm.
 - Screw the trunnion a few turns towards the front end of the rod.
 - Replace the trunnion into the hole in the idler arm and secure it with the hairpin cotter.
- Check the operation of the snow thrower. If the spiral augers still do not stop, repeat the above steps until the augers stop when the attachment clutch lever is placed in the disengaged position.

SPIRAL AUGERS

- The spiral augers are secured to the auger shaft with two shear bolts and nylock nuts. If you hit a foreign object or if ice jams the augers, the snow thrower is designed so that the bolts will shear.
- If the augers will not turn, check to see if the shear bolts have sheared. See figure 60. Two replacement shear bolts and nylock nuts have been provided with the snow thrower. For future use order part number 710-0890A shear bolt and number 47810 nylock nut.

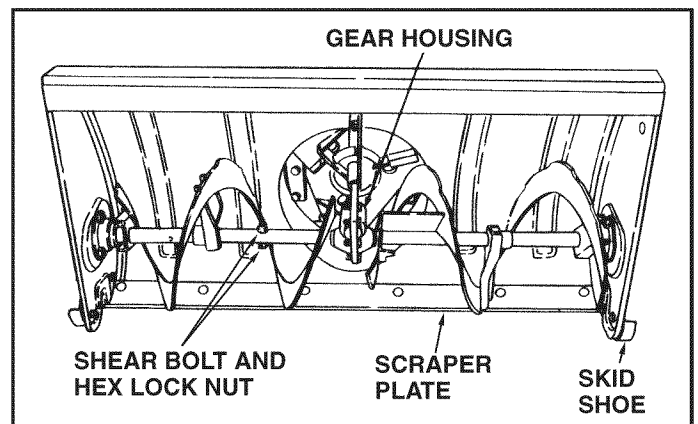

FIGURE 60

STORAGE

STORAGE RECOMMENDATIONS

- Lower the snow thrower to the ground.
- Remove the snow thrower from the tractor.
- Clean the snow thrower thoroughly. Wash off any salt deposit which may have dried on the thrower and housing.
- Any bare metal that has become exposed should be painted or coated with a light oil to prevent rust.
- Store in a dry place.

REMOVING THE SPIRAL AUGER HOUSING

- Lower the snow thrower to the ground.
- Remove the attachment pin. See figure 54 on page 24.
- Lock the snow thrower's lift handle in the down position to decrease belt tension.
- Release the spring tension from the auger belt idler arm on the bottom of the clutch/idler assembly.
- Remove the auger drive belt from the clutch/idler assembly. See figure 56 on page 24.
- Pull the spiral auger housing assembly off of the tractor.

PARTS TO REMOVE AT END OF SEASON

- Remove the clutch/idler assembly. (The two hanger brackets and the two shoulder bolts may be left attached to the tractor frame.)
- Remove the drive belt from the engine pulley.
- If you replaced the engine pulley keeper on a manual attachment clutch tractor, reinstall the tractor's original engine pulley keeper. See figure 33 on page 17 or figure 39 on page 19.
- If you have a rod operated attachment clutch, remove the engagement rod from the tractor's clutch arm. See figure 29 on page 16.
- If a front mounted attachment is to be used, remove the side plates from the tractor. Be sure to assemble bolts back into the empty holes in the tractor frame.

TROUBLESHOOTING

PROBLEM	CAUSE	CORRECTION
Spiral augers don't turn	<ol style="list-style-type: none"> 1. Upper or lower V belt too loose 2. Upper or lower V belt broken 3. Shear bolts are sheared. 	<ol style="list-style-type: none"> 1. Increase tension on V belt 2. Replace V belt 3. Replace shear bolts
Clogged discharge chute	<ol style="list-style-type: none"> 1. Tractor ground speed too fast 2. Tractor throttle set too low 3. Snow too deep 4. Snow melts during contact with the snow thrower 	<ol style="list-style-type: none"> 1. Use lower tractor gear 2. Increase to full throttle 3. Raise the snow thrower 4. Allow snow thrower to cool to outdoor temperature before using
Snow thrower stalls tractor engine	<ol style="list-style-type: none"> 1. Object jammed in spiral auger 2. Hard or heavy snow 	<ol style="list-style-type: none"> 1. Stop engine, disengage the snow thrower clutch and clear the auger 2. Increase to full throttle and decrease ground speed
Front wheels slide instead of steering	Not enough traction at front wheels	<ol style="list-style-type: none"> 1. Increase scraper plate clearance by lowering skid shoes 2. Pull down on lift handle to increase weight on front wheels
Snow thrower rides up over snow	<ol style="list-style-type: none"> 1. Tractor ground speed too fast 2. Bottom snow is icy or hard packed 	<ol style="list-style-type: none"> 1. Reduce ground speed 2. Lower the skid shoes so that front of skid shoe is lower than the rear

PARTS

REPAIR PARTS FOR MODEL 486.24837 42" SNOW THROWER (For Tractors With Model Numbers Beginning With 917)

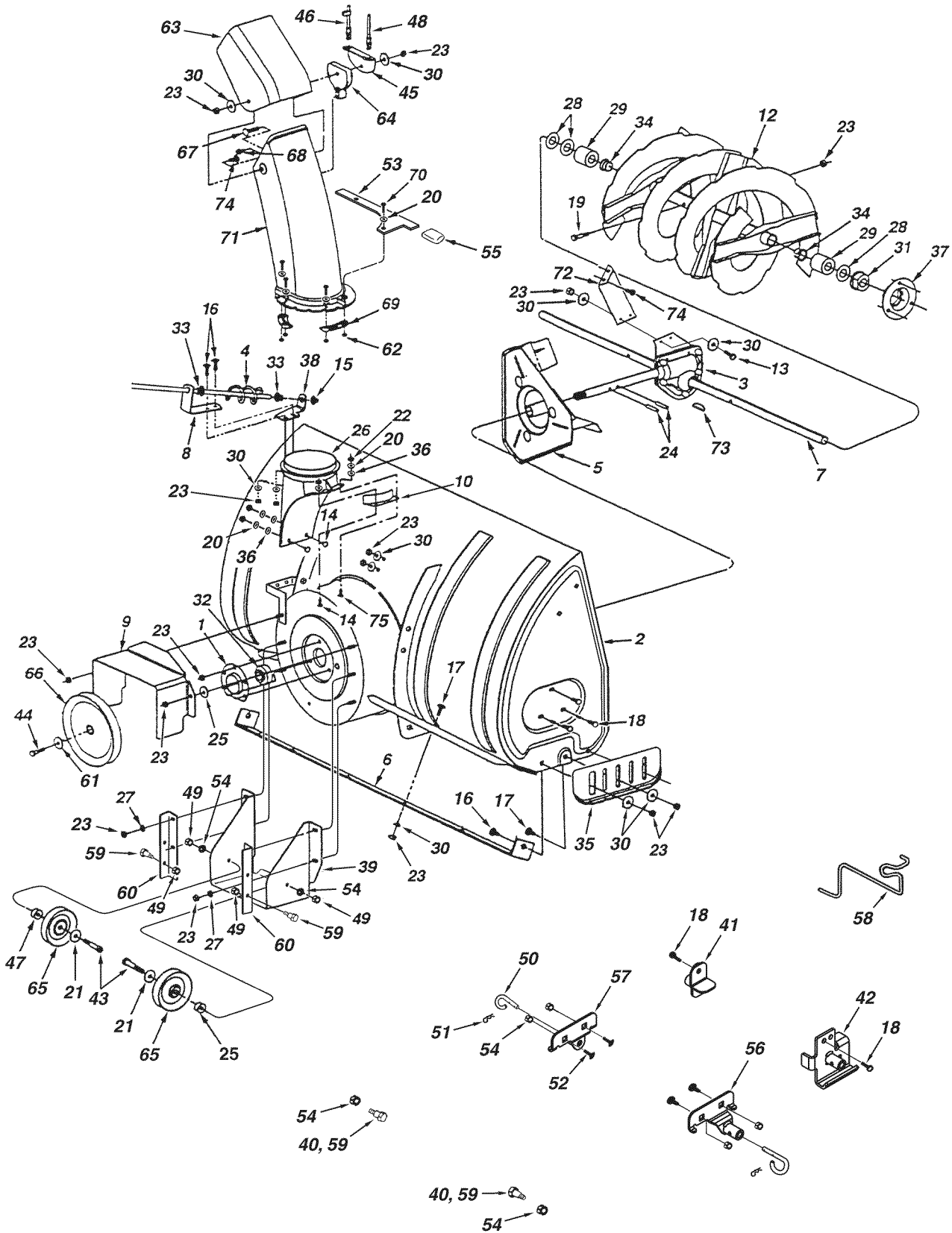

REPAIR PARTS FOR MODEL 486.24837 42" SNOW THROWER
(For Tractors With Model Numbers Beginning With 917)

REF	PART NO	QTY	DESCRIPTION	REF	PART NO	QTY	DESCRIPTION
1	05931	1	Housing, Bearing	39	24281	1	Bracket, Idler
2	65701	1	Housing Assembly	40	49933	2	Shoulder Bolt, Round Head
3	71464	1	Gear Assembly	41	65367	1	Hanger Bracket Assembly, L.H.
4	63579	1	Chute Crank Rod Assembly	42	65450	1	Hanger Bracket Assembly, R.H.
5	63768	1	Impeller Assembly	43	41576	2	Hex Bolt, 3/8-16 x 1-3/4"
6	24773	1	Scraper Plate	44	44377	1	Hex Bolt, 3/8-24 x 1"
7	25982	1	Shaft, Auger Gearbox	45	784-5594	1	Bracket, Cable
8	703-2735A	1	Bracket, Chute Crank	46	746-0929	1	Cable, Chute Control With Clip
9	24816	1	Cover, Belt	47	711-0242	1	Spacer
10	705-5226	1	Chute Reinforcement	48	746-0928	1	Cable, Chute Control
11	705-5269	1	Spiral Assembly, L.H. (not shown)	49	HA21362	4	Hex Nut, 3/8-16 Nylock
12	705-5270	1	Spiral Assembly, R.H.	50	43038	2	Pin, Pivot Lock
13	43840	2	Hex Bolt, 5/16-18 x 1-1/4" Lg.	51	43343	2	Pin, Hair Cotter #4 (1/8")
14	44950	4	Carriage Bolt, 1/4-20 x 3/4"	52	43350	4	Carriage Bolt, 3/8-16 x 1"
15	44917	1	Palnut, 3/8"	53	24394	1	Bracket, Chute Anti-rotation
16	44326	4	Carriage Bolt, 5/16-18 x 1" Lg.	54	47572	6	Hex Lock Nut, 3/8-16 Flanged
17	43080	10	Carriage Bolt, 5/16-18 x 3/4" Lg.	55	1643-60	1	Plastic Cap
18	46703	8	Bolt, Self-Tap 5/16" x 3/4"	56	64452	1	Hanger Bracket Assembly, R.H.
19	710-0890A	2	Bolt, Shear 5/16-18 x 1-1/2"	57	64451	1	Hanger Bracket Assembly, L.H.
20	43088	11	Washer, 1/4"	58	47043	1	Keeper, Engine Pulley
21	43070	2	Washer, 3/8"	59	48106	4	Bolt, Shoulder
22	47189	4	Hex Nut, 1/4-20 Nylock	60	24466	2	Bracket, Down Stop
23	47810	29	Hex Nut, 5/16-18 Nylock	61	736-0247	1	Washer,
24	715-0114	2	Spiral Pin, 1/4" x 1-1/2" Lg.	62	47598	6	Hex Lock Nut, 1/4" Flanged
25	750-0437	2	Bushing	63	731-0921	1	Chute, Upper
26	731-1379A	1	Chute Adapter	64	731-1313C	1	Guide, Cable
27	43086	4	Lock Washer, 5/16"	65	47044	2	Pulley, V Type 4"
28	736-0188	6	Washer, .76" x 1.49" x .06"	66	47026	1	Pulley, V Type
29	711-0469	4	Spacer, .75 ID x 1.25 OD x .5 L	67	43085	1	Hex Bolt, 5/16-18 x 1-1/2"
30	43081	24	Washer, 5/16" Std. Wrt.	68	710-0896	1	Screw, 1/4-14 x 5/8"
31	47615	2	Bearing, Flange	69	731-0851A	3	Chute Keeper
32	741-0309	1	Bearing, Ball	70	43661	6	Hex Bolt, 1/4-20 x 1"
33	741-0475	2	Bushing, Plastic 3/8"	71	731-1300C	1	Chute, Lower
34	741-0493A	4	Bearing, Split, 3/4"	72	25937	1	Center Brace, Gearbox
35	24279	2	Skid Shoe	73	HA20185	1	#61 Woodruff Key
36	48015	4	Washer, Nylon	74	43182	3	Hex Bolt, 5/16-18 x 3/4"
37	784-5618	2	Housing, Bearing	75	40504	1	Elevator Bolt, 1/4-20 x 1"
38	24393	1	Bracket, Chute Crank		41361	1	Owner's Manual

REPAIR PARTS FOR MODEL 486.24837 42" SNOW THROWER (For Tractors With Model Numbers Beginning With 917)

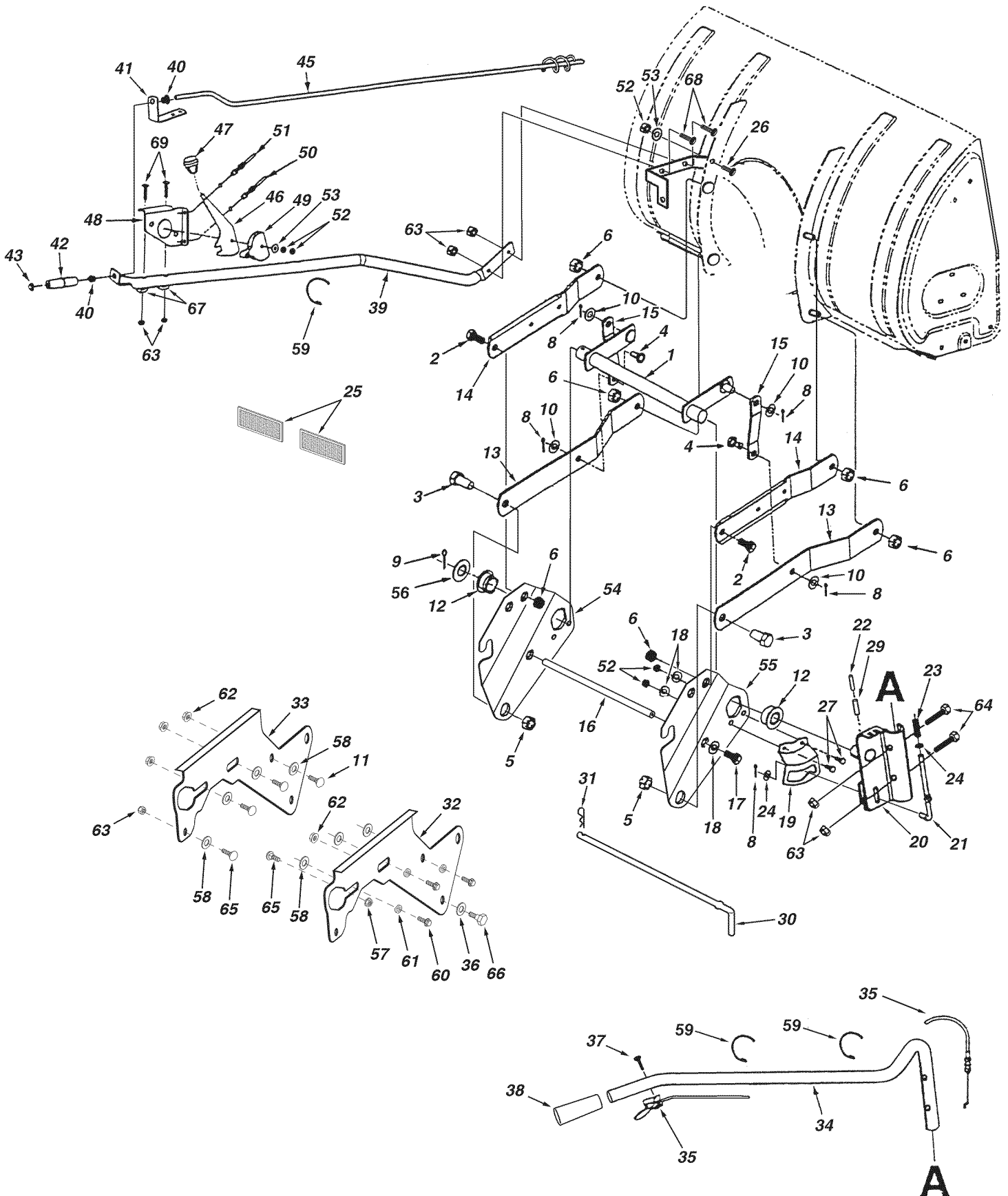

**REPAIR PARTS FOR MODEL 486.24837 42" SNOW THROWER
(For Tractors With Model Numbers Beginning With 917)**

REF	PART NO	QTY	DESCRIPTION	REF	PART NO	QTY	DESCRIPTION
1	64637	1	Lift Shaft Assembly	41	703-2735A	1	Bracket, Chute Crank
2	710-0865	2	Hex Bolt, 1/2-13 x 1"	42	720-0201A	1	Knob, Crank
3	710-0367	2	Hex Bolt, 5/8-11 x 1-1/2"	43	44917	1	Palnut, 3/8"
4	711-0332	2	Pin, Bracket Lift	45	63579	1	Assembly, Chute Crank Rod
5	712-0261	2	Nut, Hex Lock 5/8-11 Thread	46	784-5604A	1	Handle, Chute Tilt
6	43262	6	Nut, Hex Lock 1/2-13	47	720-04039	1	Knob
8	142	5	Pin, Cotter 1/8" x 3/4"	48	603-0302	1	Assembly, Chute Tilt Bracket
9	43093	1	Pin, Cotter 1/8" x 1-1/2"	49	731-1313C	1	Guide, Cable
10	R19171616	4	Washer, 17/32" x 1"	50	746-0928	1	Cable, Chute Control
11	43350	6	Carriage Bolt, 3/8-16 x 1"	51	746-0929	1	Cable, Chute Control with Clip
12	741-0192	2	Bearing, Flange With Flats	52	43064	5	Nut, Hex Lock 5/16-18
13	783-0380	2	Link, 15.80" Long	53	43081	2	Washer, 5/16"
14	783-0381	2	Link, 11.75" Long	54	24285	1	Plate, Mounting (L.H.)
15	24476	2	Link, 4.88" Long	55	24284	1	Plate, Mounting (R.H.)
16	24311	1	Rod, Spacer	56	43601	1	Washer, 1.59" x 1.032" x .060"
17	47599	2	Hex Bolt, 5/16-18 x 1" (Locking)	57	46584	1	Nut, Whizlock, 5/16-18
18	43086	4	Lock Washer, 5/16"	58	R19172410	8	Washer, 1/2"
19	24820	1	Bracket, Lift	59	726-0178	3	Tie, Nylon
20	63773	1	Assembly, Handle Lift Bracket	60	47631	6	Hex Bolt, 3/8-16 x 1" Self Tap
21	48049	1	Rod, Index Lift	61	43003	6	Lock Washer, 3/8"
22	47369	1	Pin, Spring 3/16" x 1-3/4"	62	47572	6	Nut, Flanged Lock 3/8-16
23	732-0306	1	Spring, Compression	63	47810	8	Nut, Nylock Hex 5/16-18
24	R19131316	2	Washer, 13/32" x 13/16"	64	43084	2	Hex Bolt, 5/16-18 x 1-3/4"
25	47788	2	Reflector, Rear	65	44326	2	Carriage Bolt, 5/16-18 x 1"
26	43080	1	Carriage Bolt, 5/16-18 x 3/4"	66	48106	2	Bolt, Shoulder
27	43182	2	Hex Bolt, 5/16-18 x 3/4"	67	44695	2	Washer, Bowed
29	47368	1	Pin, Spring 5/16" x 1-3/4"	68	43682	2	Carriage Bolt, 5/16-18 x 1-1/4"
30	46954	1	Pin, Attachment	69	44215	2	Carriage Bolt, 5/16-18 x 1-3/4"
31	43343	1	Pin, Haircotter #4 (1/8")				
32	25678	1	Plate, Side (R.H.)				
33	25679	1	Plate, Side (L.H.)				
34	49916	1	Tube, Lift Handle				
35	49912	1	Trigger and Lift Cable Assembly				
36	43070	2	Washer, 3/8"				
37	710-1233	1	Screw, Oval #10-24 x 1"				
38	46446	1	Grip, Handle				
39	47027	1	Tube, Crank Rod Support				
40	741-0475	2	Bushing, 3/8" Plastic				

REPAIR PARTS FOR MODEL 486.24837 42" SNOW THROWER

(For Tractors With Model Numbers Beginning With 917)

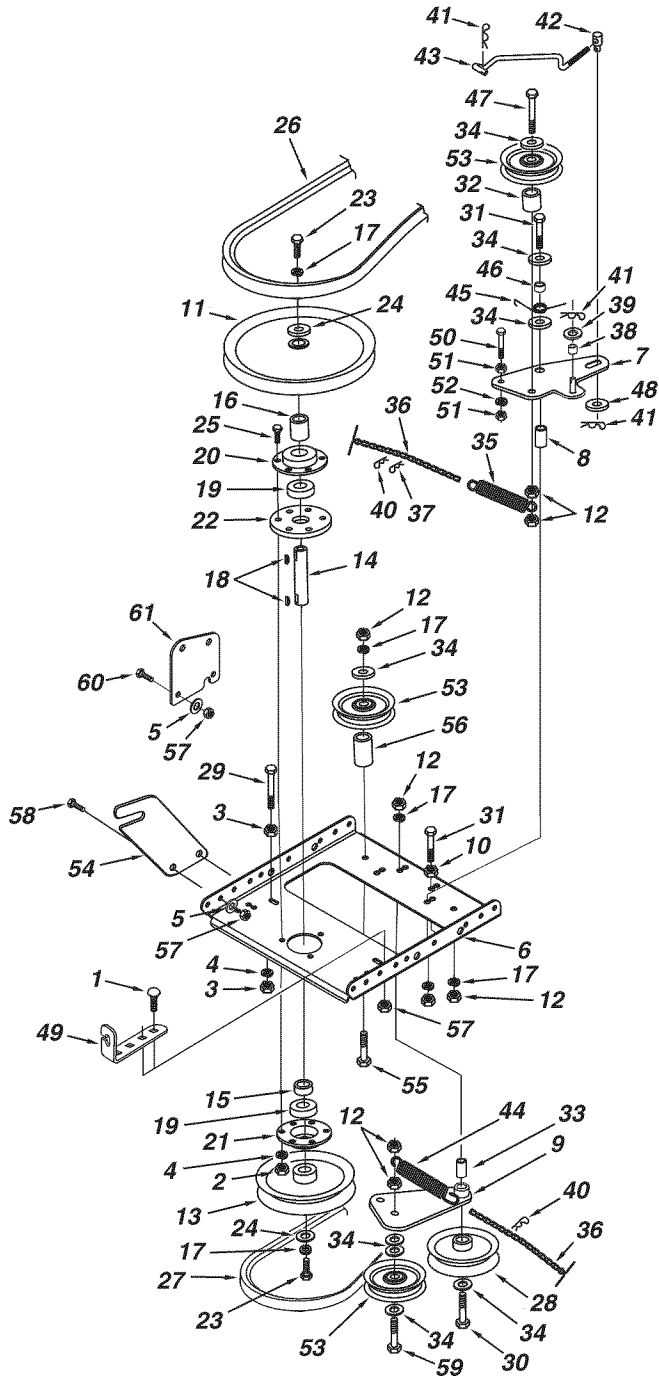

REF	PART NO	QTY	DESCRIPTION
12	43082	8	Nut, Hex Lock, 3/8-16
13	46982	1	Pulley, V Type 5-1/2"
14	738-0680	1	Shaft
15	750-0456	1	Spacer
16	750-0660	1	Spacer
17	43003	6	Lock Washer, 3/8"
18	714-0161	2	Key
19	741-0919	2	Bearing, Ball
20	08253B	1	Housing, Bearing
21	15296A	1	Housing, Open Bearing
22	14088B	1	Spacer, Spindle
23	44377	2	Hex Bolt, 3/8-24 x 1"
24	736-0247	2	Washer
25	43063	3	Hex Bolt, 5/16-18 x 1"
26	46989	1	Belt, V Type Drive (55")
	48138	1	Belt, V Type Drive (56")
27	47846	1	Belt, V Type Auger
28	47044	1	Pulley, V Type 4"
29	47025	1	Hex Bolt, 5/16-18 x 3-1/2"
30	43432	1	Hex Bolt, 3/8-16 x 2-1/2"
31	43054	2	Hex Bolt, 3/8-16 x 2"
32	24571	1	Spacer
33	24472	1	Spacer, Pivot
34	43070	8	Washer, 3/8"
35	46959	1	Spring
36	46963	2	Chain
37	43055	1	Pin, Hair Cotter, 3/32"
38	23727	1	Spacer
39	43088	1	Washer, 1/4"
40	43343	2	Pin, Hair Cotter #4 (1/8")
41	47134	2	Pin, Hair Cotter 5/64"
42	711-0198	1	Trunnion
43	46948	1	Rod, Engagement
44	47620	1	Spring
45	47607	1	Spring, Torsion
46	23625	1	Spacer
47	43509	1	Hex Bolt, 3/8-16 x 2-3/4" Lg.
48	47605	1	Washer, Flat 3/8"
49	24558	1	Cable Bracket
50	49870	1	Hex Bolt, 1/4-20 x 2-1/2"
51	43178	2	Hex Nut, 1/4-20
52	43177	1	Lock Washer, 1/4"
53	48883	3	Pulley, Flat 3-5/8"
54	25728	2	Rear Pulley Frame Bracket
55	46938	1	Hex Bolt, 3/8-16 x 3-1/4"
56	25780	1	Spacer
57	47810	10	Hex Nut, 5/16-18 Nylock
58	43182	4	Hex Bolt, 5/16-18 x 3/4"
59	HA180132	1	Hex Bolt, 3/8-16 x 2-1/4"
60	43063	4	Hex Bolt, 5/16-18 x 1"
61	27016	2	Front Pulley Frame Bracket

REF	PART NO	QTY	DESCRIPTION
1	43080	2	Carriage Bolt, 5/16-18 x 3/4"
2	43064	3	Hex Lock Nut, 5/16-18
3	43083	2	Hex Nut, 5/16-18
4	43086	4	Lock Washer, 5/16"
5	43081	20	Washer, 5/16" Std. Wrt.
6	26943	1	Frame, Clutch and Pulley
7	63904	1	Idler Arm Assembly
8	24286	1	Spacer, Pivot
9	63762	1	Idler Bracket Assembly
10	43015	1	Hex Nut, 3/8-16
11	46981	1	Pulley, V Type 9"

SUGGESTED GUIDE FOR SIGHTING SLOPES FOR SAFE OPERATION OF TRACTOR WITH ATTACHMENT

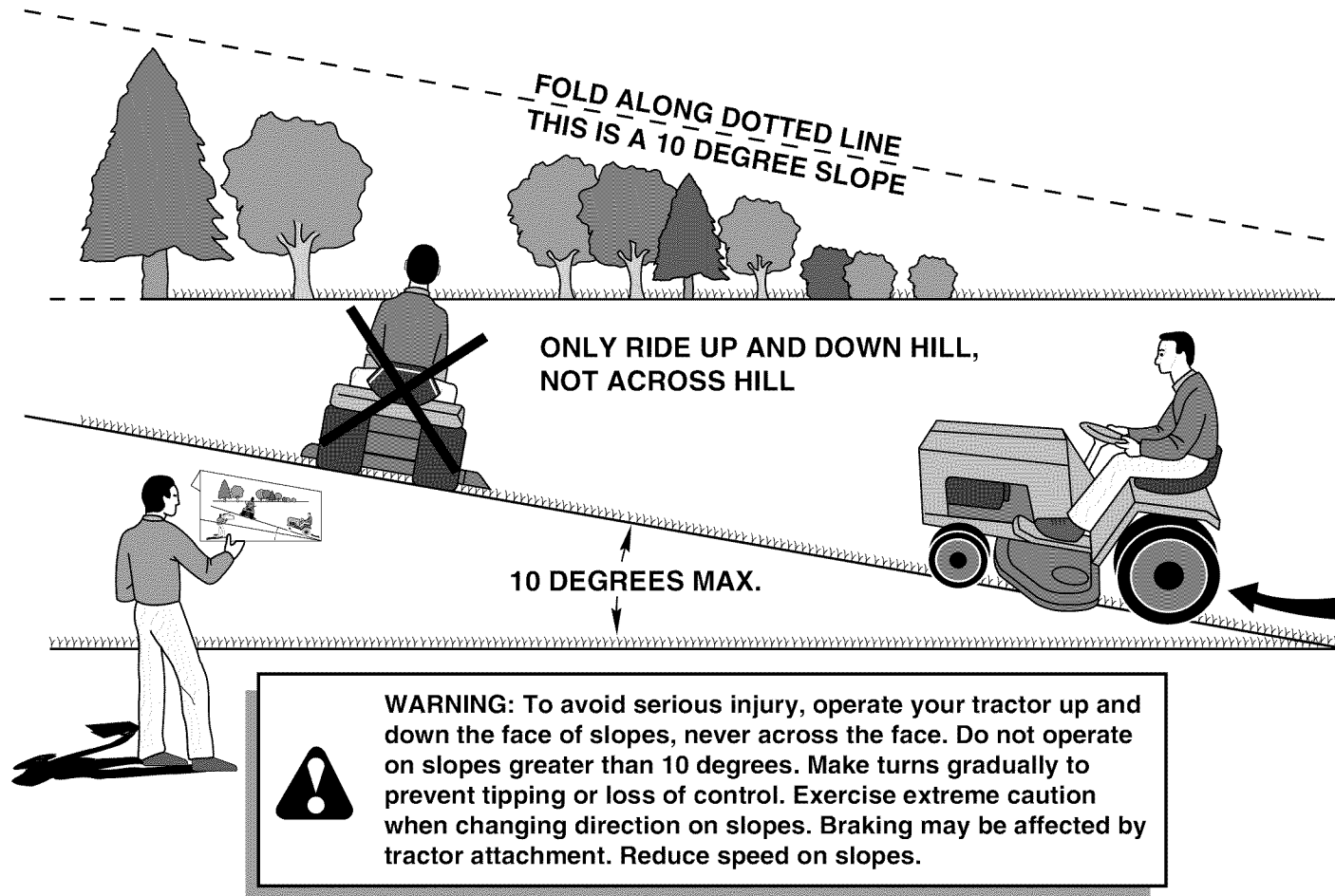

1. Fold this page along dotted line indicated above.
2. Hold page before you so that its left edge is vertically parallel to a tree trunk or other upright structure.
3. Sight across the fold in the direction of hill slope you want to measure.
4. Compare the angle of the fold with the slope of the hill.

Get it fixed, at your home or ours!

Your Home

For expert troubleshooting and home solutions advice:

manage my home

www.managemyhome.com

For repair – **in your home** – of **all** major brand appliances, lawn and garden equipment, or heating and cooling systems, **no matter who made it, no matter who sold it!**

For the replacement parts, accessories and owner's manuals that you need to do-it-yourself.

For Sears professional installation of home appliances and items like garage door openers and water heaters.

1-800-4-MY-HOME[®] (1-800-469-4663)

Call anytime, day or night (U.S.A. and Canada)

www.sears.com www.sears.ca

Our Home

For repair of carry-in items like vacuums, lawn equipment, and electronics, call anytime for the location of your nearest

Sears Parts & Repair Service Center

1-800-488-1222 (U.S.A.) **1-800-469-4663** (Canada)

www.sears.com

www.sears.ca

To purchase a protection agreement on a product serviced by Sears:

1-800-827-6655 (U.S.A.)

1-800-361-6665 (Canada)

Para pedir servicio de reparación a domicilio, y para ordenar piezas:

1-888-SU-HOGAR[®]

(1-888-784-6427)

Au Canada pour service en français:

1-800-LE-FOYER^{MC}

(1-800-533-6937)

www.sears.ca



© Registered Trademark / TM Trademark / SM Service Mark of Sears Brands, LLC

© Marca Registrada / TM Marca de Fábrica / SM Marca de Servicio de Sears Brands, LLC

^{MC} Marque de commerce / ^{MD} Marque déposée de Sears Brands, LLC

© Sears Brands, LLC