

# 96" BEAUMONT™

**SPORTCRAFT** 

Billiard Table with Pub Stools

[www.sportcraft.com](http://www.sportcraft.com)

TO ORDER PARTS, visit our website.



**WARNING!**  
ADULT ASSEMBLY  
REQUIRED.



**MODEL #: 32944 HD**  
*(no. de modelo / n° de modèle)*

Assembly and Instructions

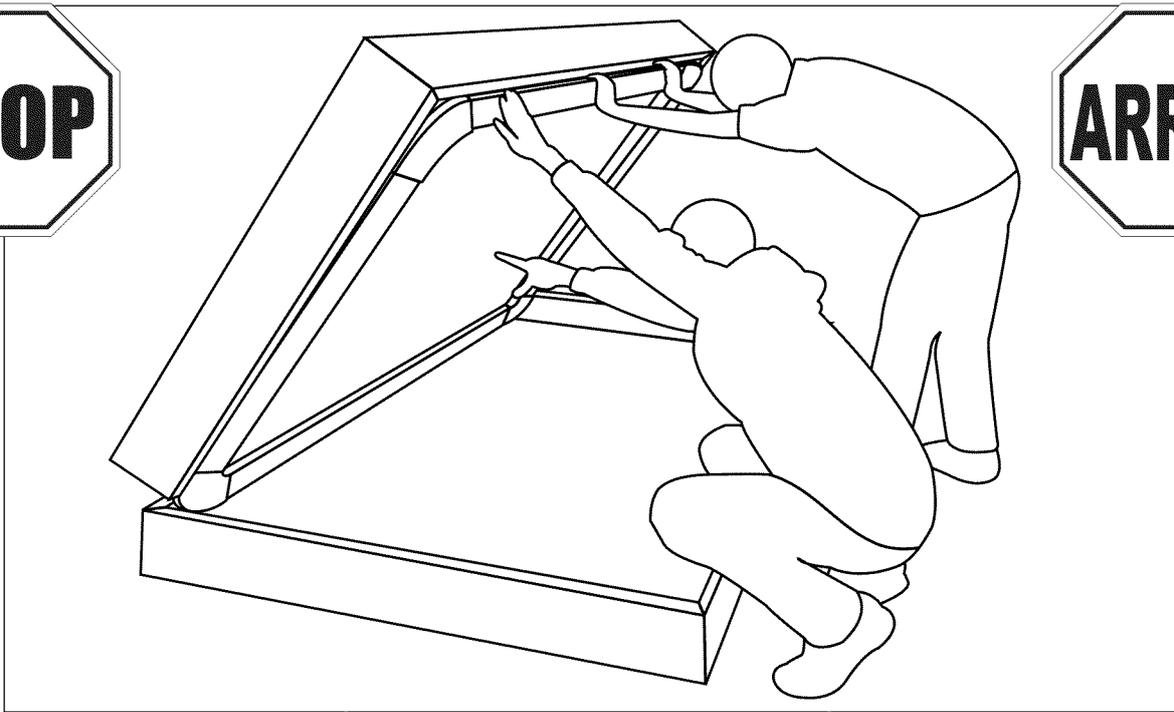

**INSPECT YOUR PLAYFIELD BEFORE ASSEMBLY!**

- Your playfield/main table frame is **NOT** replaceable and the product will need to be returned to the original place of purchase if damaged. Please make sure to check it before beginning assembly.
- Please make sure you received 2 box(es).

**¡INSPECCIONE SU SUPERFICIE DE JUGAR ANTES DE ASAMBLEA!**

- Su campo de juego/marco de mesa **NO** es reemplazable e el producto debería ser devuelto a la tienda de ser dañada. Por favor asegúrese para inspeccionarlo antes de la asamblea que comienza.
- Por favor asegúrese que usted recibió 2 caja(s).

**INSPECTEZ LA SURFACE DE JEU AVANT D'ASSEMBLER LA TABLE.**

- La table de billard doit être retournée chez le détaillant si la surface de jeu est endommagée, car celle-ci ne peut être remplacée. Assurez-vous de l'inspecter attentivement avant de procéder à l'assemblage.
- Assurez-vous s'il vous plaît que vous avez reçu 2 boîte(s).



**CONTACT INFORMATION**

*(INFORMACIÓN DE CONTACTO / POUR COMMUNIQUER AVEC NOUS)*

**Hours:** Mon.-Fri., 9:00am to 5:00pm EST

*(Horas: lunes a viernes, 9:00am a 5:00pm EST / Heures d'ouverture: du lundi au vendredi, de 9 h à 17 h HNE)*

**Replacement Parts:** [www.Sportcraft.com](http://www.Sportcraft.com) / **1-800-526-0244**

*(Piezas de recambio/ Pièces de rechange):*

**Technical Support:** **1-800-526-0244** / [CustomerService@Sportcraft.com](mailto:CustomerService@Sportcraft.com)

*(Soporte técnico / Assistance technique)*

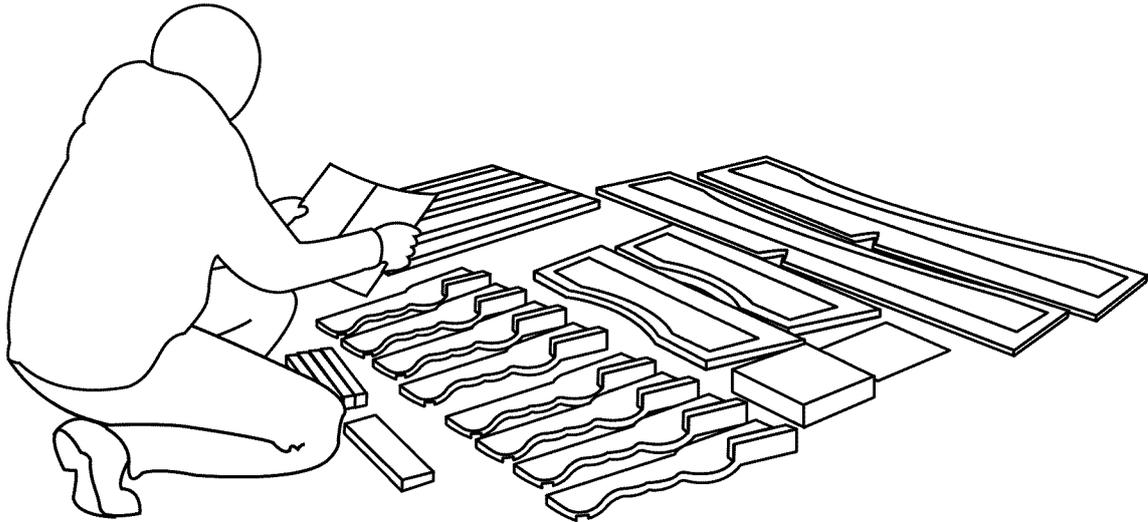
**IMPORTANT!**

PLEASE KEEP YOUR INSTRUCTIONS AND RECEIPT/PROOF-OF-PURCHASE!

- Please review the replacement parts guide and make sure that you have all your parts before beginning assembly.
- For questions that may arise or for missing/damaged parts, PLEASE CONTACT US AT **1-800-526-0244** BEFORE RETURNING THE GAME TO THE STORE.
- Please keep your Proof-of-Purchase (or Store Receipt) with your manual. Your model number and proof-of-purchase will be required for you to receive customer service help and warranty parts service. Please staple below.

**¡IMPORTANTE!**

¡IMPORTANTE! ¡POR FAVOR GUARDE ESTAS INSTRUCCIONES Y SU RECIBO/PRUEBA-DE-COMPRA!

- Por favor consultar la guía de piezas de recambio y asegurarse que usted tiene todas sus piezas antes de comenzar la asamblea.
- Para preguntas o para piezas que no se hayan incluidos/dañadas, POR FAVOR PÓNGASE EN CONTACTO CON NOSOTROS AL **1-800-526-0244** ANTES DE DEVOLVER A LA TIENDA.
- Por favor guardar su prueba-de-compra (o su recibo de tienda) con su manual. Su número de modelo y su prueba-de-compra serán requeridos para recibir la ayuda del servicio de consumidor y del servicio para las piezas conforme a la garantía. Por favor graparlo debajo.

**IMPORTANT!**

CONSERVEZ CES INSTRUCTIONS ET VOTRE REÇU OU PREUVE D'ACHAT!

- Avant de commencer l'assemblage, utilisez le guide des pièces pour vous assurer que vous avez toutes les pièces.
- Si vous avez des questions ou qu'il vous manque des pièces, COMMUNIQUEZ AVEC NOUS EN COMPOSANT LE 1-800-526-0244 AVANT DE RETOURNER L'ARTICLE AU MAGASIN.
- Gardez votre preuve d'achat avec le présent guide d'assemblage. Vous aurez besoin de votre preuve d'achat et du numéro de modèle pour avoir droit au service à la clientèle et pour commander des pièces sous garantie. Veuillezagrafer votre preuve d'achat ci-dessous.

**STAPLE YOUR RECEIPT HERE –**

Proof-of-Purchase is required to order parts under warranty.

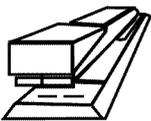
**GRAPA SU RECIBO AQUÍ-**

*La prueba-de-compra es requerido para ordenar piezas conforme a la garantía.*

**AGRAFEZ VOTRE REÇU ICI-**

*La preuve d'achat est exigée pour commander des pièces sous garantie.*

**Do Not Use or Keep Product  
Outdoors. For Indoor Use Only.  
No Wet/Humid Conditions.**



**No use y no guarde el producto  
al aire libre. Para el empleo de  
interior sólo. Ningunas condiciones  
mojadas/húmedas.**



**Ne ni utiliser ni garder le produit  
au grand air. Pour l'utilisation  
d'intérieur seulement. Aucune  
condition humide.**

**⚠ WARNING!**

This is not a child's toy. Adult supervision is required for children playing this game. Please read instructions carefully. Proper use of this set can avoid damage or injury.

**⚠ CHOKING HAZARD -- Product contains small balls and/or small parts. Not for children under 3 years.**

**⚠ ¡ADVERTENCIA!**

Esto no es un juguete de niños. La asamblea adulta es requerida antes del empleo. La supervisión adulta es requerida cuando los niños juegan este juego. Por favor leer las instrucciones con cuidado. El empleo apropiado de este juego puede evitar el daño o la herida.

**⚠ RIESGO DE ASFIXIA - el producto contiene pequeñas pelotas y/o pequeñas piezas. No es apropiado para niños menores de 3 años.**

**⚠ ATTENTION!**

Ce jeu n'est pas un jouet d'enfant. L'assemblée d'un adulte est exigée avant l'emploi. La présence d'un adulte est nécessaire lorsque des enfants jouent à ce jeu. Veuillez lire les instructions attentivement. L'utilisation appropriée de ce jeu peut prévenir les dommages matériels et les blessures.

**⚠ RISQUE D'ASFIXIATION - le produit contient des petites balles et/ou des petites pièces. N'est pas indiqué pour enfants sous 3 ans.**

**LIMITED WARRANTY**

Sportcraft, Ltd. (the "Company") warrants the Product to be free from defects in workmanship and materials under normal use and conditions **FOR A PERIOD OF 90 DAYS FROM THE DATE OF ORIGINAL PURCHASE** in the United States and Canada.

**Product Registration Card**

The Product Registration Card must be filled out completely and mailed to the Company at the address printed on the card within 10 days from the date of your purchase of the Product.

**What Is Covered**

Except as provided below, this Limited Warranty covers all defects in materials and workmanship. This Limited Warranty is void if the Product is:

- Damaged through improper usage, negligence, misuse, abuse, transportation damage, acts of nature, or accident (including failure to follow the instructions supplied with the Product)
- Used in commercial applications or rentals
- Modified or repaired by anyone not authorized by the Company.

**What Is Not Covered**

This Limited Warranty does not cover:

- Any expendable items such as batteries, light bulbs, fuses, accessories, cosmetic parts, tools and other items that wear out due to normal usage.
- Any costs you may incur for delivery, installation, assembly or transport of your product.

**What The Company Will Pay For**

If during the Limited Warranty period, any part or component of the Product is found by the Company to be defective, the Company will, at its option, repair the Product, replace the Product with a new Product (either the same or an equivalent model) or cause the original retailer of the Product to exchange the Product with a new Product (either the same or an equivalent model) or refund the original purchase price of the Product, without charge for labor or parts. The Company's obligation to repair, replace or exchange the Product, however, shall be limited to the amount of the original purchase price of the Product.

**How To Obtain Warranty Service**

In order to enforce your rights under this Limited Warranty, you must follow these procedures:

- You must have completed and mailed the Product Registration Card to the Company within 10 days of purchase of the Product.
- You must include **THE ORIGINAL COPY OF YOUR SALES RECEIPT**.
- You must call the Company's Consumer Service Department at 1-800-526-0244 from 9:00 A.M. to 5:00 P.M. (EST) to notify the Company of the nature of the problem.
- If you are instructed to return the Product to the Company for servicing, you are responsible for shipping the Product, at your expense, to the address designated by the Company in packaging that will protect against further damage.
- You must also include your name, address, daytime telephone number, model number of the Product and a description of the problem.

**THIS LIMITED WARRANTY IS AVAILABLE ONLY TO THE ORIGINAL PURCHASER OF THE PRODUCT AND IS VALID IN THE UNITED STATES AND CANADA ONLY.**

**THE COMPANY'S LIABILITY IS LIMITED TO THE REPAIR OR REPLACEMENT, AT ITS OPTION, OF ANY DEFECTIVE PRODUCT AND SHALL NOT INCLUDE ANY LIABILITY FOR INDIRECT, INCIDENTAL OR CONSEQUENTIAL DAMAGES OF ANY KIND.**

**THIS WARRANTY IS EXPRESSLY MADE IN LIEU OF ALL OTHER WARRANTIES, EXPRESSED OR IMPLIED.**

**SOME STATES DO NOT ALLOW LIMITATIONS ON HOW LONG AN IMPLIED WARRANTY LASTS OR DO NOT ALLOW FOR EXCLUSION OF INCIDENTAL OR CONSEQUENTIAL DAMAGES. TO THAT EXTENT, THE ABOVE LIMITATIONS MAY NOT APPLY TO YOU.**

This Limited Warranty gives you specific legal rights, but you may also have other rights that vary from state to state.

If you have questions regarding this Limited Warranty or the operation of the Product, you may call or write us:

Consumer Service Department  
313 Waterloo Valley Rd.  
Budd Lake, NJ 07498  
1-530-526-0244  
www.sportcraft.com

Printed in China

32944 HD

**GARANTIA LIMITADA**

Sportcraft, Ltd. (la "Compañía") garantiza que este producto no tiene defectos de fabricación ni materiales bajo condiciones y uso normales **POR UN PERIODO DE 90 DÍAS A PARTIR DE LA FECHA DE COMPRA ORIGINAL**, en Estados Unidos y Canadá.

**Tarjeta de registro del producto**

La tarjeta de registro del producto se debe llenar por completo y enviar por correo a la Compañía a la dirección impreso sobre la tarjeta dentro de 10 días a partir de la fecha de compra del Producto.

**La cobertura**

Esta garantía cubre todos los defectos de fabricación y materiales, excepto lo que se indica a continuación. Esta garantía limitada no tiene validez si el producto:

- Se daña por uso inapropiado, negligencia, mal uso, abuso, daño de transporte, fenómenos naturales o accidentes (incluyendo el no seguir las instrucciones que se proporcionan con el producto).
- Se usa en aplicaciones comerciales o se alquila
- Alguna persona no autorizada por la Compañía lo modifica o repara.

**Lo que la garantía no cubre**

La garantía limitada no cubre:

- Ningún artículo perecedero tales como baterías, focos, fusibles, accesorios, partes cosméticas, herramientas, y otros artículos que se gastan con el uso normal.
- Ningún gasto que se puede incurrir para la entrega, la instalación, la asamblea o el transporte de su producto.

**Pagos de la Compañía**

Si durante el periodo de la Garantía Limitada, la Compañía determina que alguna pieza o componente del producto tiene defectos, a su discreción, lo reparará o reemplazará el Producto con un nuevo Producto (ya sea con un modelo similar o equivalente) o causa la tienda original del Producto para cambiar el Producto con un Producto nuevo (sea con un modelo similar o equivalente) o reembolsa el precio de compra original del Producto, sin cargos por la mano de obra o las piezas. La obligación de la Compañía de reparar, sustituir, o reemplazar el Producto, sin embargo, será limitada con el precio de compra original del Producto.

**Cómo obtener servicios de garantía**

Para hacer cumplir sus derechos de esta Garantía Limitada, debe seguir estos procedimientos:

- Debe haber completado y ha enviado la tarjeta de registro de Producto a la Compañía dentro de 10 días de compra del Producto.
- Debe incluir **LA COPIA ORIGINAL DE SU RECIBO DE LAS VENTAS**.
- Debe llamar al departamento de Servicio al Cliente de la Compañía al 1-800-526-0244 entre las 9:00 A.M. y 5:00 P.M. (hora del este) para notificar a la Compañía la naturaleza del problema.
- Si está instruido a devolver el Producto a la Compañía para la manutención, está responsable para el envío del Producto, a su gusto, a la Compañía a la dirección situada debajo, en un embalaje que protegerá contra el remoto daño.
- Asimismo, debe incluir su nombre, dirección, número de teléfono durante el día, el modelo del producto y una descripción del problema.

**ESTA GARANTÍA LIMITADA ES DISPONIBLE SÓLO AL COMPRADOR ORIGINAL DEL PRODUCTO Y ES VÁLIDA SOLAMENTE EN ESTADOS UNIDOS Y CANADA.**

**LA RESPONSABILIDAD DE LA COMPAÑÍA SE LIMITA A REPARAR O REEMPLAZAR, A SU DISCRECIÓN, CUALQUIER PRODUCTO DEFECTUOSO Y NO INCLUIRÁ RESPONSABILIDAD POR DAÑOS INDIRECTOS, INCIDENTALES O CONSECUENTES DE NINGUNA CLASE.**

**ESTA GARANTÍA OTORGADA SUPERSEDE A CUALQUIER OTRA GARANTÍA, EXPRESO O IMPLÍCITO.**

**ALGUNOS ESTADOS NO PERMITEN LIMITACIONES EN LA DURACIÓN DE GARANTÍAS IMPLÍCITAS O NO PERMITEN LA EXCLUSIÓN DE DAÑOS CONSECUENTES O INCIDENTALES. EN ESE CASO, LAS LIMITACIONES MENCIONADAS ARRIBA NO SE APLICAN A USTED.**

Esta garantía limitada le otorga derechos legales específicos, pero usted también tiene otros derechos que varían de un estado a otro.

Si tiene alguna pregunta con respecto a esta Garantía Limitada o la operación del producto, usted puede llamar o escribir a:

Consumer Service Department  
313 Waterloo Valley Rd.  
Budd Lake, NJ 07498  
1-530-526-0244  
www.sportcraft.com

Impreso en China

(Siga a la página siguiente.)

**GARANTIE LIMITÉE**

Sportcraft Ltd. (la «compagnie») garantit le produit contre tout défaut de fabrication et de matériel si celui-ci est utilisé dans des conditions normales, **POUR UNE PÉRIODE DE 90 JOURS À PARTIR DE LA DATE D'ACHAT INITIALE**, aux États-Unis et au Canada.

**Fiche d'enregistrement de produit**

L'acheteur doit remplir la fiche d'enregistrement du produit et la poster à la compagnie à l'adresse imprimée sur la carte, dans les 10 jours de la date d'achat du produit.

**Ce qui est couvert**

La garantie limitée couvre tous les défauts de matériel et de fabrication, à l'exception de ce qui suit. Cette garantie limitée est nulle si le produit est :

- endommagé à cause d'une mauvaise utilisation, de négligence, d'abus, du transport, d'un imprévu ou d'un accident (y compris en cas de non respect des instructions d'utilisation)
- utilisé à des fins commerciales ou de location
- modifié ou réparé par une personne non autorisée par la compagnie

**Ce qui n'est pas couvert**

Cette garantie limitée ne couvre:

- aucun article courant comme des piles, des ampoules, des fusibles, des accessoires, des pièces décoratives, des outils ou des autres articles qui subissent une usure normale.
- aucune dépense que vous pouvez encourir pour la livraison, l'installation, l'assemblage ou le transport de votre produit.

**Frais assumés par la compagnie**

Si au cours de la période de garantie limitée de la compagnie, cette dernière juge qu'une pièce ou une composante du produit est défectueuse, la compagnie, à son choix, réparera le produit ou remplacera le produit par un nouveau produit (soit du même modèle ou d'un modèle équivalent) ou exigera du détaillant du produit d'échanger le produit avec un nouveau produit (soit du même modèle ou d'un modèle équivalent) ou de rembourser le prix d'achat original du produit, sans frais de main-d'œuvre ou de pièces. L'obligation de la compagnie de réparer, remplacer ou échanger le produit, cependant, sera limitée au montant total du prix d'achat original du produit.

**Service offert dans le cadre de la garantie**

Pour faire valoir vos droits conformément à la présente garantie limitée, il faut suivre la méthode suivante:

- Vous êtes tenu de remplir et d'expédier par la poste la fiche d'enregistrement de produit à la
- compagnie dans un délai de 10 jours suivant l'achat du produit.
- Vous devez inclure **LA COPIE ORIGINALE DE VOTRE REÇU DE CAISSE**.
- Vous devez communiquer avec le Service à la clientèle de la compagnie en composant le 1 800 526-0244, de 9 h à 17 h (HNE) pour aviser la compagnie de la nature du problème.
- Si on vous demande de retourner le produit à la compagnie aux fins de service, vous êtes responsable d'expédier le produit à la compagnie, à vos frais, à l'adresse indiquée par la compagnie. Vous devez emballer le produit de sorte qu'il ne subisse pas de dommages supplémentaires.
- Vous devez également inclure votre nom, votre adresse, votre numéro de téléphone (de jour), le numéro de modèle du produit et une description du problème.

**CETTE GARANTIE LIMITÉE EST OFFERTE SEULEMENT À L'ACHETEUR INITIAL DU PRODUIT ET EST VALIDE AUX ÉTATS-UNIS ET AU CANADA SEULEMENT.**

**LA RESPONSABILITÉ DE LA COMPAGNIE SE LIMITE À LA RÉPARATION OU AU REMPLACEMENT, À SON CHOIX, DE TOUT PRODUIT DÉFECTUEUX. LA COMPAGNIE N'EST PAS RESPONSABLE DES DOMMAGES INDIRECTS, ACCESSOIRES OU CONSÉCUTIFS DE TOUTES SORTES.**

**CETTE GARANTIE REMPLACE EXPRESSÉMENT TOUTE AUTRE GARANTIE, EXPRIMÉE OU IMPLICITE.**

**CERTAINS ÉTATS NE PERMETTENT PAS QU'UNE LIMITE SOIT IMPOSÉE QUANT À LA DURÉE D'UNE GARANTIE IMPLICITE OU NE PERMETTENT PAS QUE LES DOMMAGES ACCESSOIRES OU CONSÉCUTIFS SOIENT EXCLUS. IL EST POSSIBLE QU'À CET ÉGARD, LES RESTRICTIONS CI-DESSUS NE S'APPLIQUENT PAS À VOUS.**

Cette garantie limitée vous accorde certains droits légaux spécifiques, mais il est possible que vous ayez d'autres droits qui peuvent varier d'un état à l'autre ou d'une province à l'autre.

Si vous avez des questions au sujet de la présente garantie limitée ou du fonctionnement du produit, communiquez avec ou écrivez à:

Consumer Service Department  
313 Waterloo Valley Rd.  
Budd Lake, NJ 07498  
1-530-526-0244  
www.sportcraft.com

Imprimé en Chine

## TOOLS REQUIRED

### HERRAMIENTAS NECESARIAS / OUTILS NÉCESSAIRES



Do Not Use Drill  
No use el taladro  
Ne pas utiliser de perceuse



Phillips and Slotted Head Screwdrivers (not included)  
Destornilladores Phillips y de cabeza ranurada  
(no incluido)  
Tournevis Philips ou tournevis pour vis à tête fendue  
(non inclus)



Allen Wrenches (included)  
Llave hexagonales (incluida)  
Clé hexagonales (incluse)

## PARTS GUIDE

### GUÍA DE PIEZAS / GUIDE DES PIÈCES

**For replacement, missing or defective parts, order online or call:**

Para las piezas de recambio, que faltan o defectuosas, ordenar a la página web o pongase en contacto:  
Pour obtenir des pièces de rechange, commandez en ligne ou composez le numéro sans frais:

**www.sportcraft.com**

**1-800-526-0244**

#### EXAMPLE CONSUMER-INSTALL PART

(Pieza de ejemplo instalada por el consumidor/  
Exemple de pièce à installer par le consommateur)

 ID # (No. de secuencia/ N° d'ordre)	34 (X 4) Quantity (Cantidad/Quantité)	LEG LEVELER - 9.5 MM NIVELADOR DE LA PIERNA DE 9.5 MM VÉRIN DE CALAGE 9.5 MM	= No Shading (Ningún color/ Fond blanc)	Part Number (No. de pieza/ N° de pièce)
32932ES26				

#### EXAMPLE PRE-INSTALLED PART

(Pieza de ejemplo preinstalada/  
Exemple de pièce préinstallée)

 ID # (No. de secuencia/ N° d'ordre)	17 (X 2) Quantity (Cantidad/Quantité)	POCKET - CORNER BUCHACA DE ESQUINA POCHÉ DE COIN	= Shading (color/Fond ombragé)	Part Number (No. de pieza/ N° de pièce)
32932ES17				

#### TABLE & LEG COMPONENTS / COMPONENTES DE MESA Y PIERNA / COMPOSANTS DE LA TABLE ET DES PIED

1  (X 4)	LEG    32944HD01	2  (X 2)	APRON - SIDE    32944HD02
3  (X 2)	APRON - END    32944HD03	4  (X 4)	POCKET - CORNER - EXTERNAL    32944HD04

(Siga a la página siguiente.)

REPLACEMENT PARTS: [www.sportcraft.com](http://www.sportcraft.com)  
 PIEZAS DE RECAMBIO / PIÈCES DE RECHANGE

 Shaded box = pre-installed part (Caja coloreada = pieza preinstalada / Boîte colorée = pièce préinstallée)

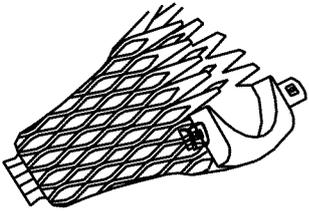
5		POCKET - SIDE - EXTERNAL
		(X2) <b>32944HD05</b>

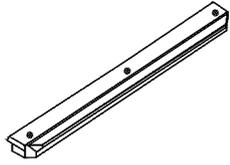
6		SIDE TOP RAIL - LEFT
		(X2) <b>32944HD06</b>

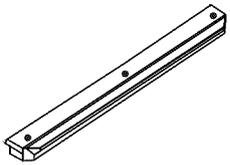
7		END TOP RAIL
		(X2) <b>32944HD07</b>

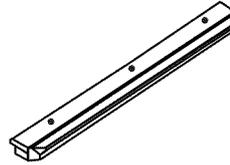
8		SIDE TOP RAIL - RIGHT
		(X2) <b>32944HD08</b>

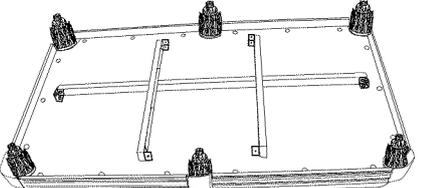
9		MAIN CABINET - BILLIARD
		(X1) <b>32944HD09</b>

ADDITIONAL PIECES / PIEZAS ADICIONALES / PIÈCES COMPLÉMENTAIRES

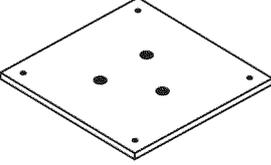
14		SUPPORT BOARD
		(X 1) <b>32944HD14</b>

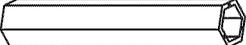
15		PUB TABLE - POLE
		(X 1) <b>32944HD15</b>

REPLACEMENT PARTS: [www.sportcraft.com](http://www.sportcraft.com)  
 PIEZAS DE RECAMBIO / PIÈCES DE RECHANGE

 Shaded box = pre-installed part (Caja coloreada = pieza preinstalada / Boîte colorée = pièce préinstallée)

 (X 1)	TABLE TOP
	<b>32944HD16</b>

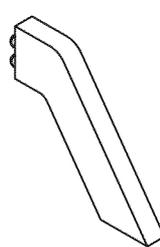
 (X 3)	TABLE LEG
	<b>32944HD17</b>

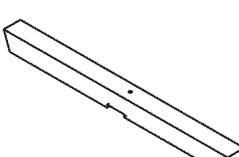
 (X 2)	LEG FRAME - A
	<b>32944HD18</b>

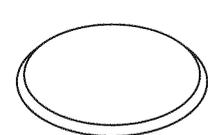
 (X 2)	TOP STOOL
	<b>32944HD19</b>

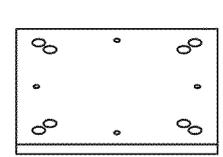
 (X 2)	SUPPORT BOARD - STOOL
	<b>32944HD20</b>

 (X 4)	LEG A - STOOL
	<b>32944HD21</b>

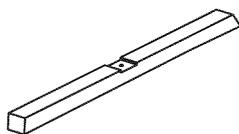
 (X 2)	LEG FRAME - B
	<b>32944HD22</b>

 (X 3)	SUPPORT BOARD RAIL
	<b>32944HD23</b>

 (X 4)	LEG B - STOOL
	<b>32944HD24</b>

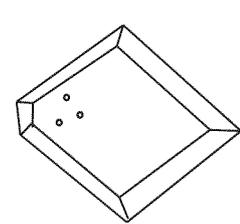
 (X 4)	LEG SUPPORT BOARD
	<b>32944HD25</b>

(Siga a la página siguiente.)

REPLACEMENT PARTS: [www.sportcraft.com](http://www.sportcraft.com)

PIEZAS DE RECAMBIO / PIÈCES DE RECHANGE

 Shaded box = pre-installed part (Caja coloreada = pieza preinstalada / Boîte colorée = pièce préinstallée)

**SMALL PRODUCT PARTS / PEQUEÑAS PIEZAS DE PRODUCTO / PETITES PIÈCES DE PRODUIT**

 (X 2)	NAME PLATE - SPORTCRAFT
	<b>32944HD29</b>

**ACCESSORIES & MAINTENANCE / ACCESORIOS Y MANTENIMIENTO / ACCESSOIRES ET PIÈCES D'ENTRETIEN**

 (X 1)	BRUSH
	<b>32944HD36</b>

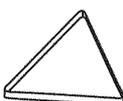
 (X 1)	TRIANGLE - 2.25"
	<b>32944HD37</b>

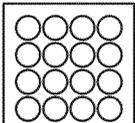
 (X 1)	BILLIARD BALL SET - 2.25"
	<b>32944HD38</b>

 (X 2)	CUE - 2PC - 57"
	<b>32944HD39</b>

 (X 2)	CHALK - GREEN
	<b>32944HD40</b>

 (X 2)	CUE TIP
	<b>32944HD41</b>

 (X 3)	SHIM - 1 MM
	<b>32944HD42</b>

 (X 3)	SHIM - 2 MM
	<b>32944HD43</b>

 (X 3)	SHIM - 3 MM
	<b>32944HD44</b>

 (X 10)	SCREW CAP
	<b>32944HD45</b>

(Siga a la página siguiente.)

REPLACEMENT PARTS: [www.sportcraft.com](http://www.sportcraft.com)  
 PIEZAS DE RECAMBIO / PIÈCES DE RECHANGE

 Shaded box = pre-installed part (Caja coloreada = pieza preinstalada / Boîte colorée = pièce préinstallée)

**HARDWARE & TOOLS / FERRETERÍA Y HERRAMIENTA / QUINCAILLERIE ET OUTILS**

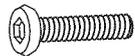
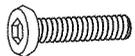
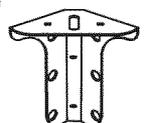
<p>50</p>  <p>(X 10)</p>	<p>WASHER - 6 X12 MM</p> <hr/> <hr/> <p><b>32944HD50</b></p>	<p>51</p>  <p>(X 37)</p>	<p>BOLT - ALLEN KEY - 6 X51 MM - 4 MM</p> <hr/> <hr/> <p><b>32944HD51</b></p>	<p>52</p>  <p>(X 4)</p>	<p>BOLT - ALLEN KEY - 6 X 28 MM - 4 MM</p> <hr/> <hr/> <p><b>32944HD52</b></p>
<p>53</p>  <p>(X 9)</p>	<p>SCREW - FLAT HEAD - 4 X 32 MM</p> <hr/> <hr/> <p><b>32944HD53</b></p>	<p>54</p>  <p>(X 14)</p>	<p>BOLT - ALLEN KEY - 6 X 30 MM - 4 MM</p> <hr/> <hr/> <p><b>32944HD54</b></p>	<p>55</p>  <p>(X 4)</p>	<p>BRACKET - B</p> <hr/> <hr/> <p><b>32944HD55</b></p>
<p>56</p>  <p>(X 1)</p>	<p>WRENCH - ALLEN KEY - 4 MM</p> <hr/> <hr/> <p><b>32944HD56</b></p>	<p>57</p>  <p>(X 1)</p>	<p>WRENCH - ALLEN KEY - 5 MM</p> <hr/> <hr/> <p><b>32944HD57</b></p>	<p>58</p>  <p>(X 2)</p>	<p>BRACKET - A</p> <hr/> <hr/> <p><b>32944HD58</b></p>
<p>59</p>  <p>(X 8)</p>	<p>BRACKET - C</p> <hr/> <hr/> <p><b>32944HD59</b></p>	<p>60</p>  <p>(X 4)</p>	<p>BOLT - ALLEN KEY - 9.5 X 66 MM - 5 MM</p> <hr/> <hr/> <p><b>32944HD60</b></p>	<p>61</p>  <p>(X 4)</p>	<p>WASHER - 9.5 MM</p> <hr/> <hr/> <p><b>32944HD61</b></p>
<p>62</p>  <p>(X 4)</p>	<p>SPRING WASHER - 9.5 MM</p> <hr/> <hr/> <p><b>32944HD62</b></p>	<p>63</p>  <p>(X 14)</p>	<p>BOLT - ALLEN KEY - 6 X 17 MM - 4 MM</p> <hr/> <hr/> <p><b>32944HD63</b></p>	<p>64</p>  <p>(X 24)</p>	<p>WASHER - 8 MM</p> <hr/> <hr/> <p><b>32944HD64</b></p>
<p>65</p>  <p>(X 24)</p>	<p>SPRING WASHER - 8 MM</p> <hr/> <hr/> <p><b>32944HD65</b></p>	<p>66</p>  <p>(X 59)</p>	<p>WASHER - 6 MM</p> <hr/> <hr/> <p><b>32944HD66</b></p>	<p>67</p>  <p>(X 24)</p>	<p>BOLT - ALLEN KEY - 8 X 22 MM - 4 MM</p> <hr/> <hr/> <p><b>32944HD67</b></p>
<p>68</p>  <p>(X 55)</p>	<p>SPRING WASHER - 6 MM</p> <hr/> <hr/> <p><b>32944HD68</b></p>	<p>69</p>  <p>(X 4)</p>	<p>METAL BRACKET</p> <hr/> <hr/> <p><b>32944HD69</b></p>		

(Siga a la página siguiente.)



**Strong Adults Needed: 4**

*Adultos fuertes necesarios*

Adultes forts requis



**No Children in Assembly Area**

*Ningunos niños en el área de asamblea*

Aucun enfant dans le secteur d'assemblée



**No Pets in Assembly Area**

*Ningunas mascotas en el área de asamblea*

*Pas d'animaux domestiques dans la zone d'assemblage*

English	Español	Français
<p><b><u>ASSEMBLY INSTRUCTIONS:</u></b></p> <p><b>We recommend that 4 adults work together to assemble this table.</b></p> <ul style="list-style-type: none"> <li>• The table will be assembled upside down and then turned over onto its legs. This is a very heavy table and turning it over will require 4 strong adults.</li> <li>• We suggest that you use the bottom carton as a clean flat work area to protect the table.</li> </ul>	<p><b><u>INSTRUCCIONES DE ENSAMBLAJE</u></b></p> <p><b>Recomendamos que 4 adultos ayuden a armar esta mesa.</b></p> <ul style="list-style-type: none"> <li>• La mesa puede armarse de manera invertida y después darse vuelta para que se asiente sobre las piernas. Esta mesa es pesado y para darle vuelta será necesaria la participación de 4 adultos fuertes.</li> <li>• Sugerimos que utilice el fondo de la caja como área de trabajo limpia y plana para la protección de la mesa.</li> </ul>	<p><b><u>INSTRUCTIONS D'ASSEMBLAGE</u></b></p> <p><b>Nous recommandons de confier l'assemblage de cette table à 4 adultes.</b></p> <ul style="list-style-type: none"> <li>• La table doit être assemblée à l'envers, puis retournée sur ses pieds. La table étant très lourde, il faut 4 adultes pour la retourner.</li> <li>• Pour éviter d'endommager la table durant l'assemblage, travaillez sur une surface propre et de niveau et utilisez le carton de la boîte comme tapis protecteur.</li> </ul>

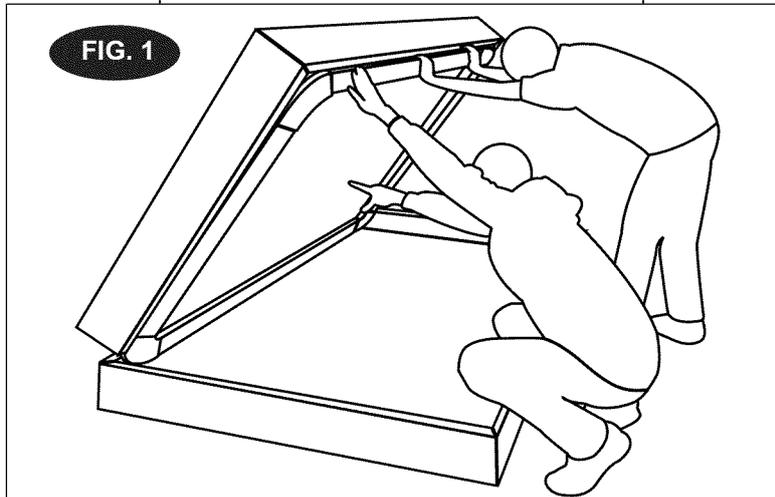

**STEP 1:**

- Your playfield/main table frame is NOT replaceable and the product will need to be returned to the original place of purchase if damaged. Please make sure to check it before beginning assembly.

**PASO 1:**

- Su campo de juego/marco de mesa no es reemplazable e el producto debe ser devuelto a la tienda de ser dañada. Por favor asegúrese para inspeccionarlo antes de la asamblea que comienza.

**ÉTAPE 1:**

- La table de billard doit être retournée chez le détaillant si la surface de jeu est endommagée, car celle-ci ne peut être remplacée. Assurez-vous de l'inspecter attentivement avant de procéder à l'assemblage.

(Siga a la página siguiente.)

**STEP 2:**

- Attach the Side Aprons (#2) and End Aprons (#3) to the Main Cabinet (#9) using eight Brackets (#59), fourteen Bolts (#63) and fourteen Washers (#66). See Fig. 2 and 2A.

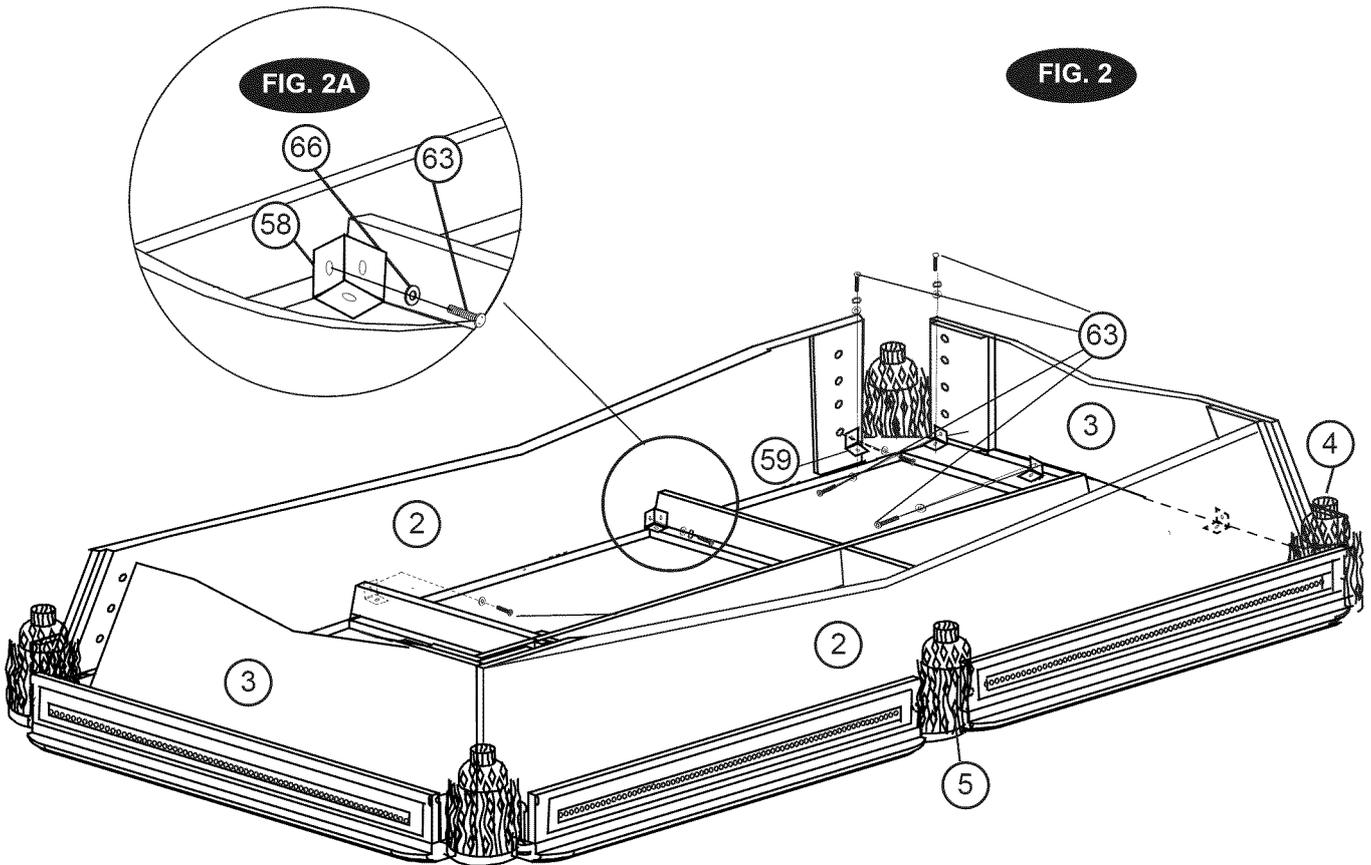
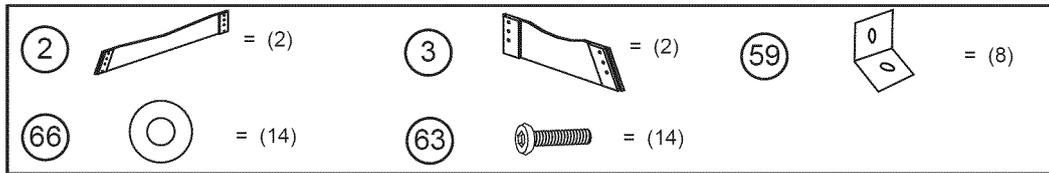

**STEP 3:**

- Attach the Leg Bracket (#69) to the Leg Support Board (#25) using two Bolts (#51), two Spring Washers (#68), and two Washers (#66) through the outer holes. **NOTE:** Make sure to align each Screw with the outer hole.
- Then insert one Bolt (#60), one Spring Washer (#62), and one Washer (#61) into the center hole as shown in Fig. 3.
- Repeat the same for the other legs.

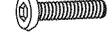
1		= (4)
25		= (4)
51		= (8)
60		= (4)
61		= (4)
62		= (4)
66		= (8)
68		= (8)
69		= (4)

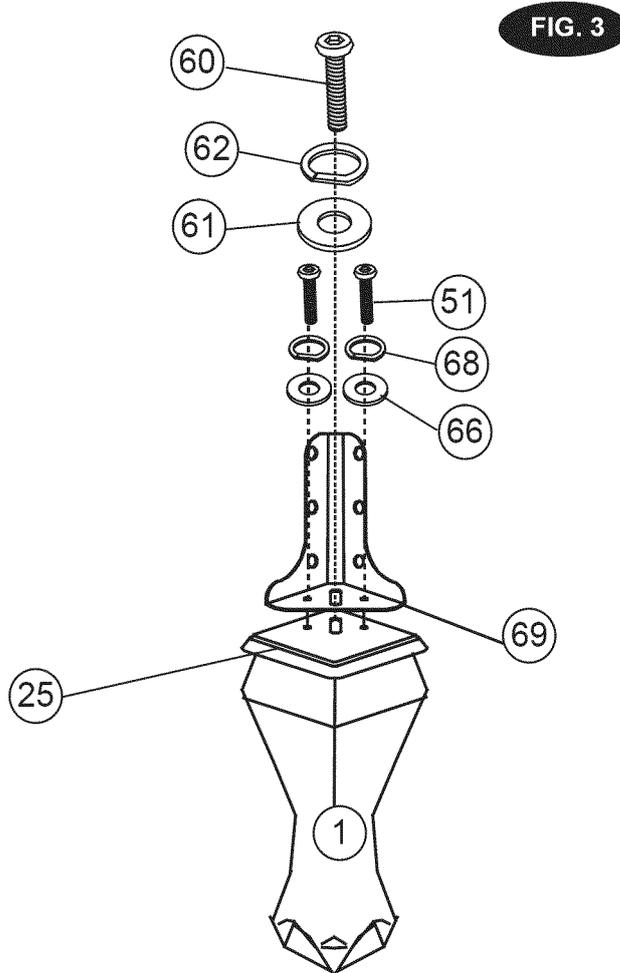

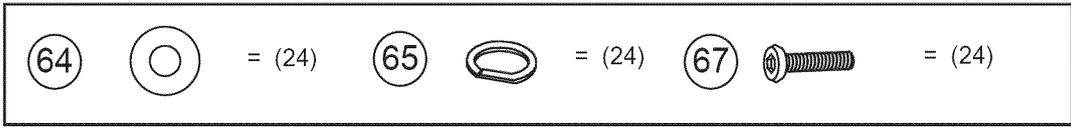
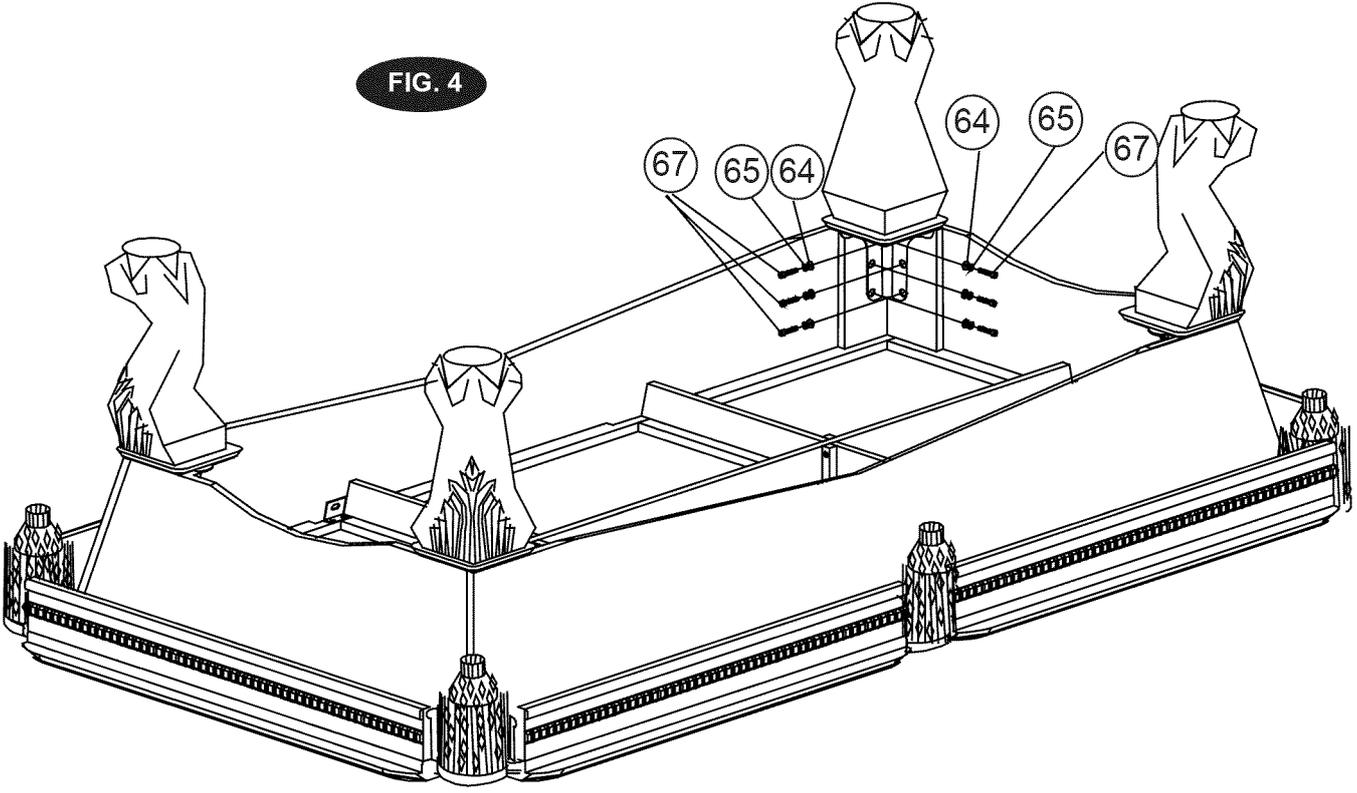

FIG. 4



**STEP 4:**

- Attach the Leg assembly to table assembly using six Bolts (#67), six Washers (#64), and six Spring Washers (#65).
- Repeat the same step for the other three Legs.

**STEP 5:**

- Before flipping the table, make sure all bolts are tightened.
- Using four adults, lift the table by the rails and turn over, so the table stands upright. Do not lift by pockets, legs, or aprons, as this may result in table damage.
- **NOTE:** DO NOT lift the table by the pockets. If you move the table, do not lift it by placing your hands beneath the pockets and do not lean or put pressure on them. Do not lean or sit on the end or side rails as this may damage the table.
- **NOTE:** If the table height is uneven, place Shims (#42, 43, and 44) under the legs to adjust. See Fig. 5.

**FIG. 5**

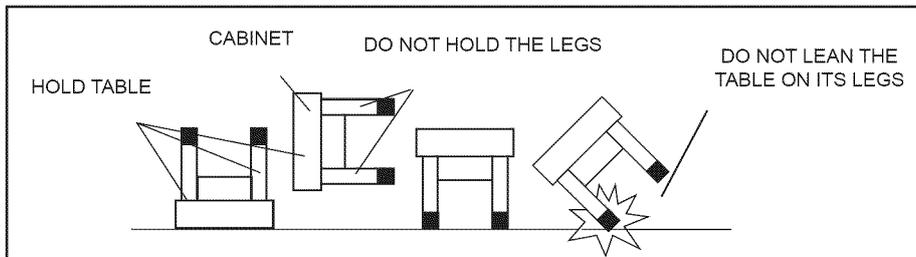
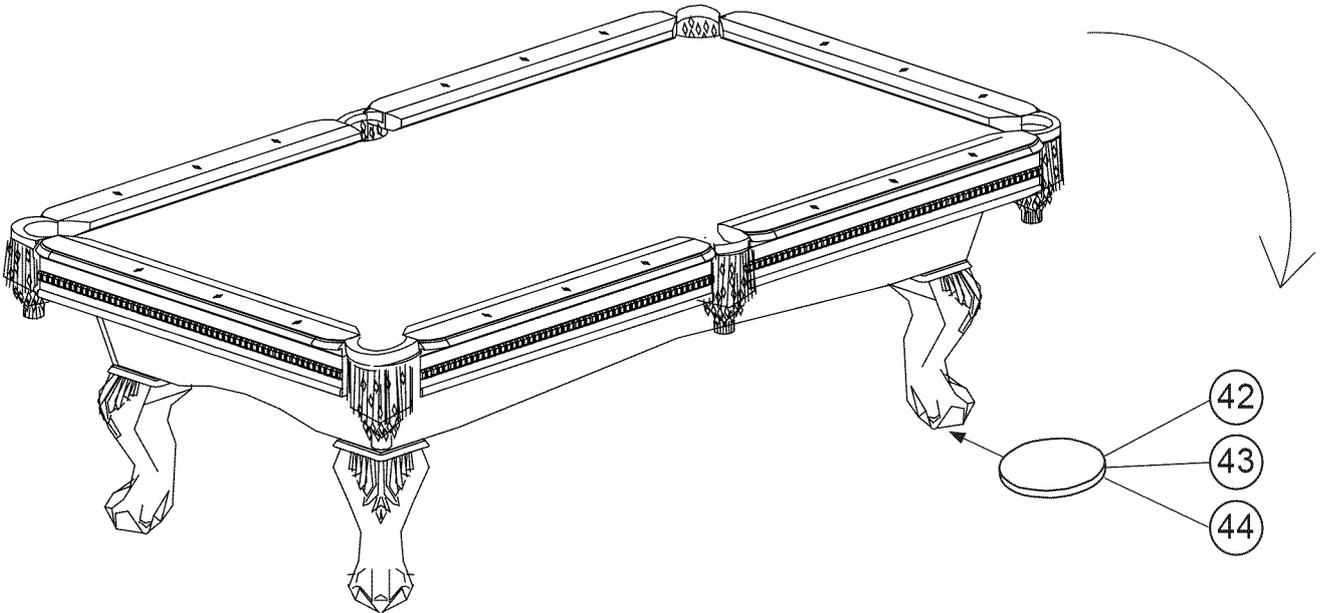

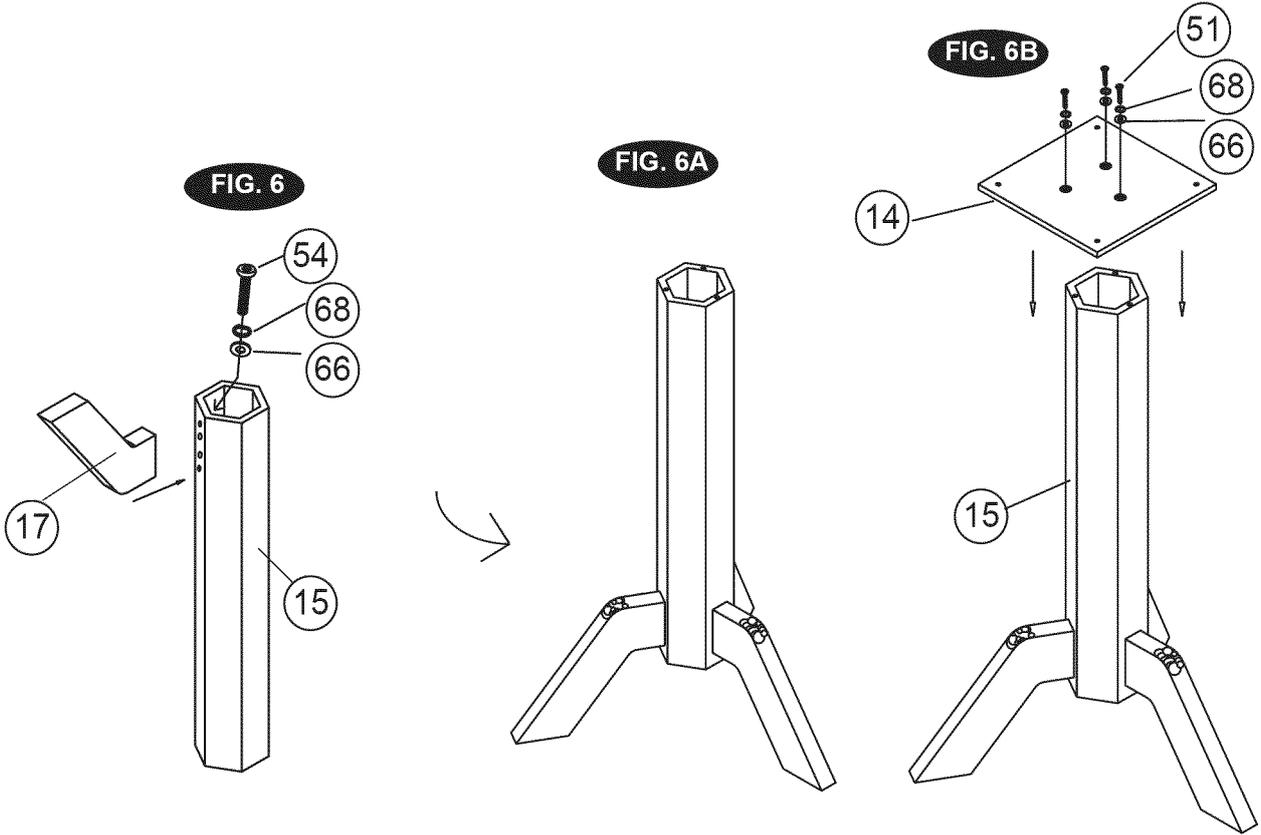
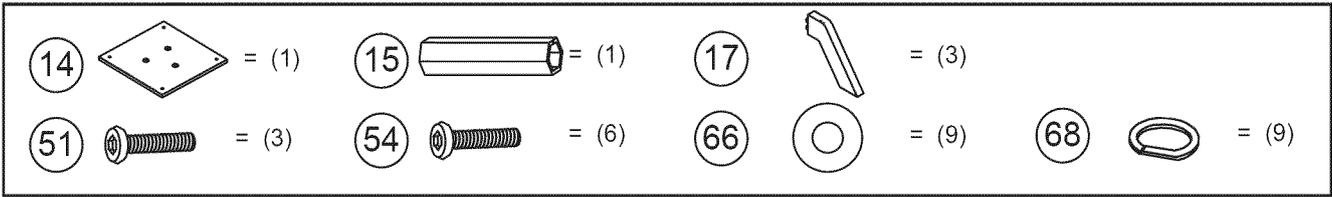

**STEP 6:**

- **NOTE:** Before assembly, place carton on the floor.
- Attach the Table Legs (#17) to the Pole (#15) using two Bolts (#54), two Washers (#66) and two Spring Washers (#68) per Leg. Repeat the same steps for the other Legs.
- Carefully turn over the Leg assembly.
- Attach the Support Board (#14) to the Leg assembly using three Bolts (#51), three Washers (#66), and three Spring Washers (#68).

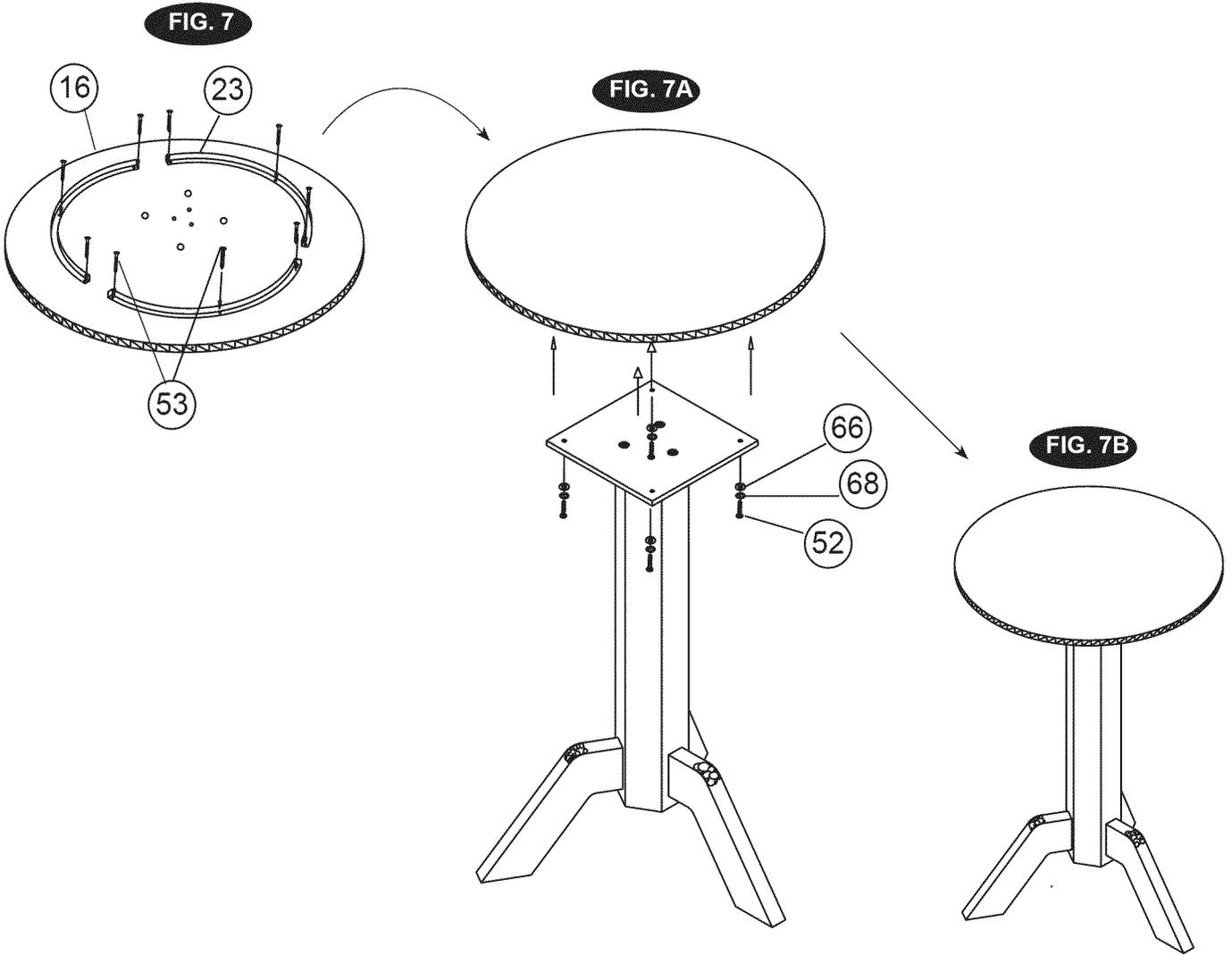
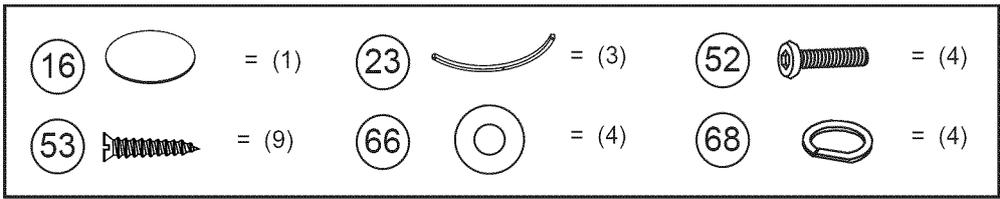

**STEP 7:**

- Attach the Support Rails (#23) to the table top (#16) using three Screws (#53) per Support Rail. Repeat for the other Rails.
- Carefully turn over the Table top assembly.
- Attach the Table top assembly to the Leg assembly from under side using four Bolts (#52), four Washers (#66), and four Spring Washers (#68).

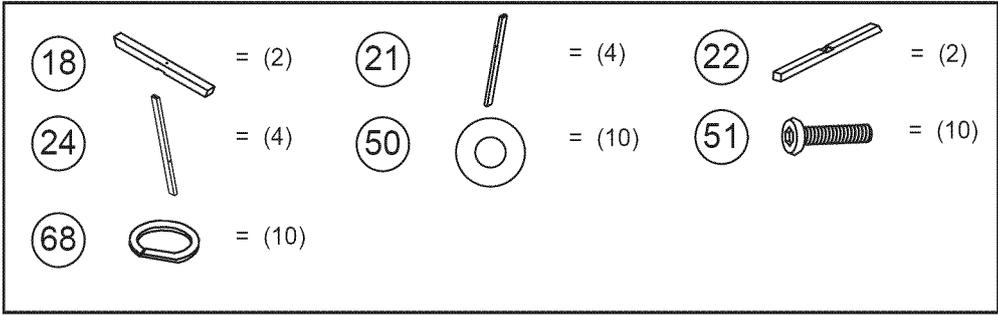

FIG. 8

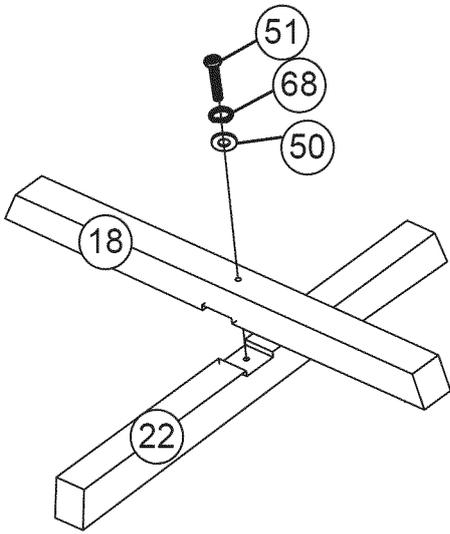
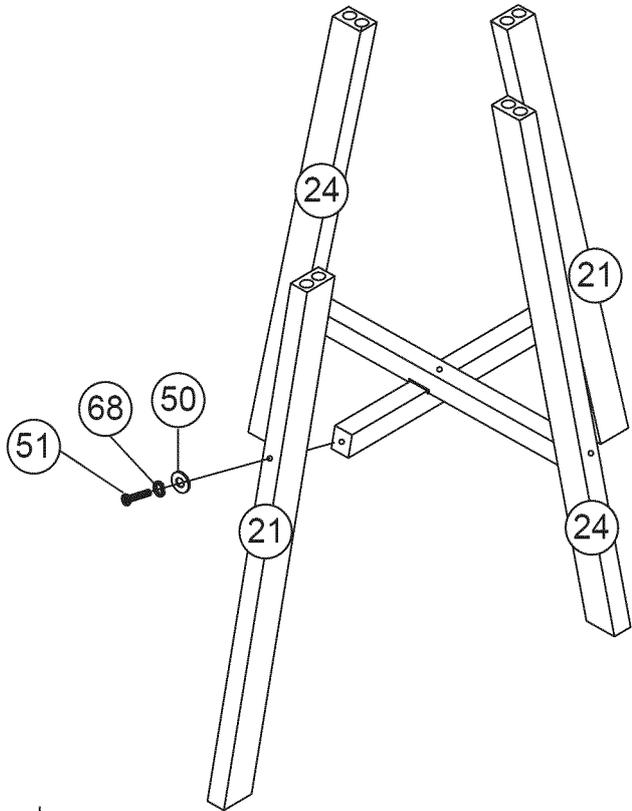
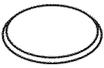
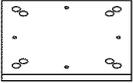

FIG. 8A



**STEP 8:**

- Attach the Leg Frame - A (#18) to the Leg Frame - B (#22) using one Bolt (#51), one Washer (#50), and one Spring Washer (#68). See Fig. 8.
- Then attach the Legs, A and B, of the Stool (#21 and 24) to the Leg Frame assembly using four Bolts (#51), four Washers (#50), and four Spring Washers (#68). See Fig. 8A.
- Repeat the above steps for the other Leg Frames and Leg Stools.

19		= (2)	20		= (2)	45		= (10)	51		= (16)
54		= (8)	66		= (24)	68		= (24)			

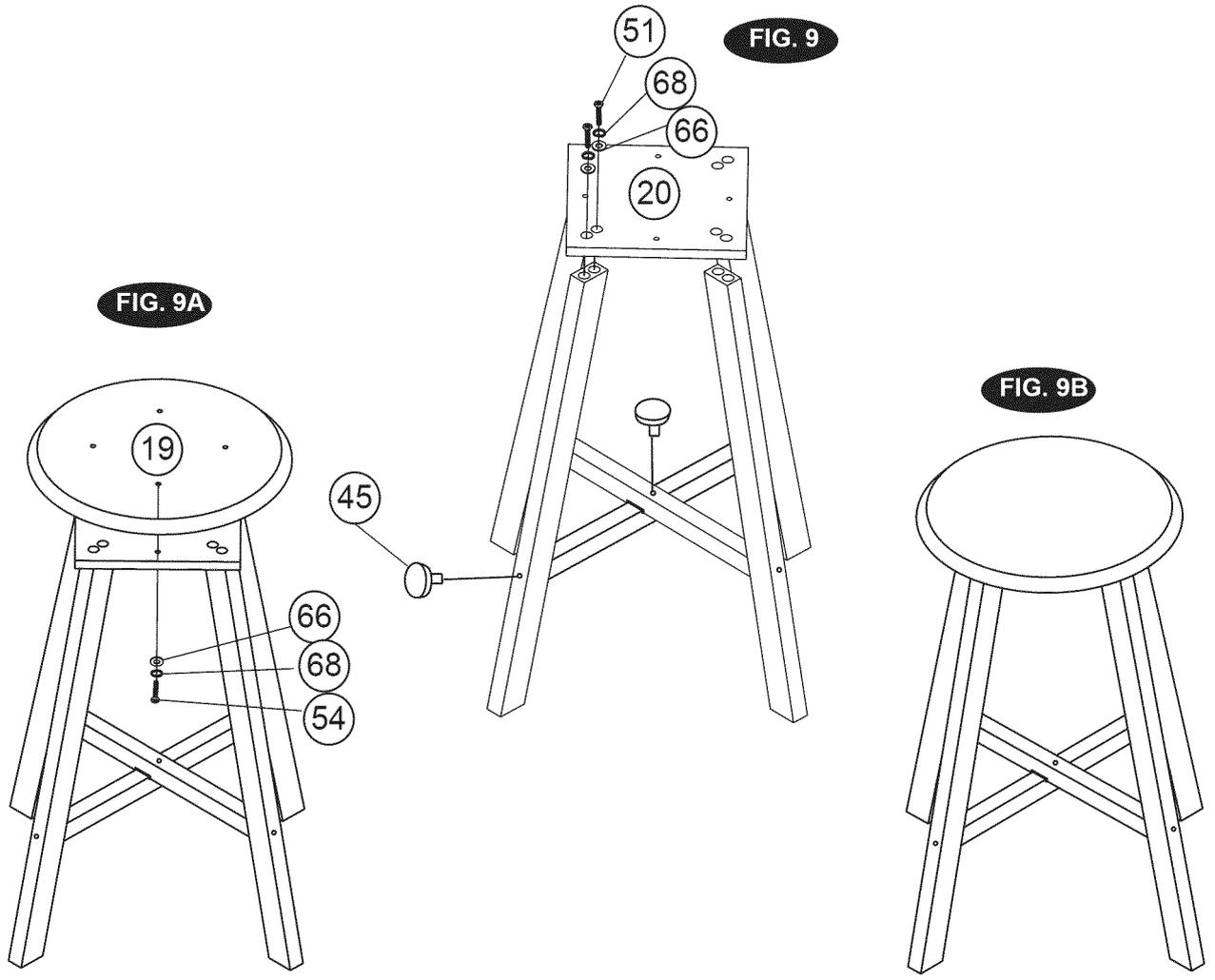

**STEP 9:**

- Attach the Support Board - Stool (#20) to the Leg assembly using eight Bolts (#51), eight Washers (#66), and eight Spring Washers (#68). See Fig. 9.
- Insert Screw Caps (#45) into the Screws. See Fig. 9.
- Then attach Top assembly stool to the Leg assembly from underneath using four Bolts (#54), four Washers (#66), and four Spring Washers (#68).
- Repeat the above steps for the other Stool.

TABLE MAINTENANCE /MANTENIMIENTO DE LA MESA/ ENTRETIEN DE TABLE	
TABLE Mesa Table	Keep your table covered. If there is dust on the playfield or the aprons, use a vacuum or use the brush provided to remove. Do not sit on the table and do not use the table outside.
	<i>Cubra su mesa. Si hay el polvo sobre el campo de juego o los guarniciones, use un vacío o el cepillo provisto para quitarlo. No siéntese sobre la mesa y no utilice la mesa afuera.</i>
	<i>Gardez la table couverte. S'il y a de la poussière sur la surface de jeu et les ceintures de la table, éliminez-la avec un aspirateur ou la brosse fournie. Ne vous assoyez pas sur la table et n'utilisez pas la table à l'extérieur.</i>
POCKETS Buchacas Poches	DO NOT lift the table by placing your hands under the pockets, and do not sit, lean or put pressure on the pockets.
	<i>NO levante la mesa por sosteniendo sobre las buchacas y no siéntese, ni inclínese, ni haga presión sobre las buchacas.</i>
	<i>NE SOULEVEZ JAMAIS la table en plaçant vos mains sous les poches, ne vous appuyez pas sur les poches, et n'exercez pas de pression sur celles-ci.</i>
LEGS Piernas Pattes	Check that all the edges fit properly into the grooves of the caps. When moving the table, lift the table off of its legs and place it down squarely on the legs, do not drag the table (and do not lift by the pockets).
	<i>Asegúrese que los pernos de pierna son bien apretados. En moviendo la mesa, levante la mesa de sus piernas y colóquelo abajo directamente sobre las piernas, no arrastre la mesa (y no levante por las buchacas).</i>
	<i>Assurez-vous que les rebords s'emboîtent bien dans les rainures. Si vous devez déplacer la table, soulevez-la et déposez-la une fois à l'endroit voulu. Ne la traînez pas sur le sol et ne la soulevez pas par les poches.</i>

**Frequently Asked Questions (FAQs):**

1) **Q:** How can I tell which table rail is the left or right?

**A:** The left and right of a table are determined by the player's starting position. See illustration below.

- 1 = Left
- 2 = Right
- 3 = End

2) **Q:** How do I level my table?

**A:** Place a level in three different locations on the table parallel to the long side of the table (A). Adjust shims (may not be included) under each leg until the level is bubbled in all three locations. See illustration below. Then repeat the same for for the short side of the table (B).

- A = long side of table
- B = short side of table

**Preguntas frecuentes (FAQs):**

1) **P:** ¿Cómo puedo determinar cual carrile de mesa es el izquierdo o el derecho?

**R:** El izquierdo y el derecho de una mesa son determinados por la posición de partida del jugador. Ver la ilustración abajo.

- 1 = Izquierdo
- 2 = Derecho
- 3 = Extremo

2) **P:** ¿Cómo nivelo mi mesa?

**R:** Colocar un nivel en tres posiciones diferentes sobre la mesa y paralela al lado largo de la mesa (A). Ajustar cuños (quizás no incluidos) bajo de cada pierna hasta que el nivel sea burbujeado en las tres posiciones. Ver la ilustración debajo. Entonces repetir el mismo sólo paralela al lado corto de la mesa (B).

- A = lado largo de mesa
- B = lado corto de mesa

**Questions courantes (les FAQ):**

1) **Q:** Comment distingue-t-on le côté gauche et le côté droit de la table ?

**R:** C'est la position du joueur au bris qui détermine le côté gauche et le côté droit de la table (voir illustration ci-dessous).

- 1 = Gauche
- 2 = Droit
- 3 = Extrémité

2) **Q:** Comment peut-on niveler la table ?

**R:** Placez un niveau à trois endroits différents sur la table, de façon qu'il soit parallèle aux longues bandes de la table (A). Réglez la hauteur de chaque patte avec des cales, jusqu'à ce que la bulle du niveau soit bien centrée, et ce, pour les trois positions du niveau (voir illustration ci-dessous). Répétez ensuite en plaçant le niveau parallèle aux bandes courtes de la table (B).

- A = long côté de table
- B = côté court de table

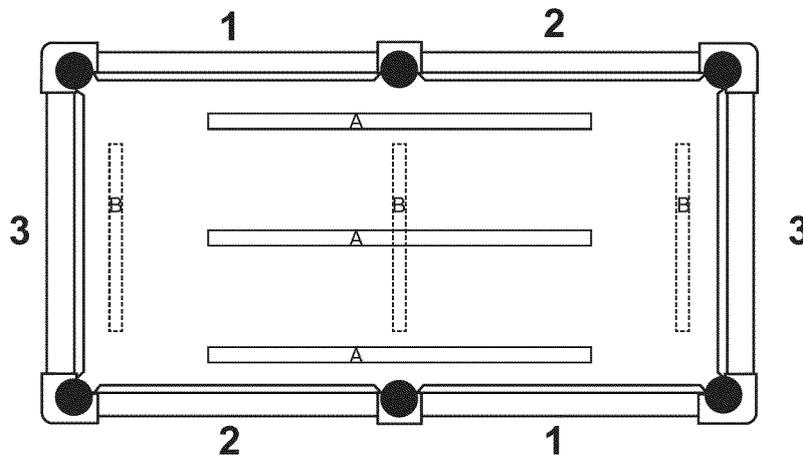

(Siga a la página siguiente.)

**BILLIARD RULES - 8 BALL**

8 Ball is a simple game enjoyed by players of all skill levels. It is a Called Shot Game, meaning that players must announce their intended shot in advance in order for it to count. In 8 Ball, one player shoots at solid balls (numbers 1 through 7), while the opponent shoots at striped balls (numbers 9 through 15). The player who pockets his or her ball group first and then sinks the 8 ball is the winner.

**THE BREAK:**

The balls are racked as shown in the illustration. A flip of a coin determines which player gets to break. In subsequent games, the loser of the previous game gets to break. The cue ball must be placed behind the head string and the shooter must either: (a) pocket a ball, or (b) drive four balls to the rails. If the shooter fails to make a legal break, the opponent has the option of accepting the balls in this position or re-racking the balls and shooting the opening break again.

If any balls are pocketed on the break: the shooter stays on the table. However the table is still Open which means that the choice of the stripes or solids is not yet determined. The choice of stripes or solids is determined by the first called shot made after the break.

If the 8 ball is pocketed on the break: the shooter stays on the table with the option of spotting the 8 ball and continuing play, or re-racking the balls and breaking again.

If the shooter scratches on the break: if the cue ball is pocketed on the break: (a) all balls pocketed remain pocketed, except the 8 ball which is spotted, (b) the table is open, (c) the opposing player has the cue ball in hand and may place it anywhere behind the head string and shoot at any ball that is not behind the head string.

**PLAYING THE GAME:**

After the break, regardless of whether any balls were pocketed on the break, the table is Open, with the choice of stripes or solids determined by the next legally pocketed ball.

In the course of play, a shooter must call a shot in advance, by indicating the ball to be made and the pocket into which it will be made. It is not necessary to indicate details such as cushions, banks, caroms, etc. Failure to make the shot as called results in a loss of turn. If the shot is made as called, then any other balls pocketed remain pocketed. However, if the called shot is not made and any other balls are pocketed, then the shooter's ball(s) that were pocketed would be spotted and any of the opponent's balls would remain pocketed.

In order to execute a Legal Shot, the first ball hit must be one of the balls in the shooter's group (stripes or solids) and the object ball must be pocketed or the cue ball or any object ball must come into contact with a rail. (Note: It is legal for the shooter to bank the cue ball off a rail before hitting the object ball.)

A player who legally pockets a ball continues play until missing or committing a Foul. Once a player's ball group (stripes or solids) is pocketed, the player may play the 8 ball. Again, the player must clearly indicate the intended pocket, even if it appears obvious. A player who legally pockets all of his ball group and the 8 ball is the winner.

**FOULS:**

1. Failure to execute a legal shot as defined above.
2. A scratch shot (shooting the cue ball into a pocket or off the table).
3. Moving or touching any ball by means other than legal play.
4. Shooting an intentional jump shot over another ball by scooping

the cue stick under the cue ball. A jump shot executed by striking the cue ball above center is legal.

- Using the 8 ball first in a combination shot when the table is not open.

**FOUL PENALTY:**

Opposing player gets "cue ball in hand." This means that the player can place the cue ball anywhere on the table (does not have to be behind the head string except on the opening break).

**SPOTTING BALLS:**

Whenever an object is to be spotted, the object ball is spotted on the long string as close to the foot spot as possible.

**LOSS OF GAME:**

A player committing any of the following infractions loses the game:

- Fouls when pocketing the 8 ball.
- Pockets the 8 ball on the same stroke as the last of his group of balls.
- Scratches when the 8 ball is his legal object ball.
- Jumps the 8 ball off the table at any time.
- Pockets the 8 ball in a pocket other than the one designated.
- Pockets the 8 ball when it is not the legal object ball (except on the break).

**BILLIARD RULES - 9 BALL**

**OBJECT OF THE GAME:**

Nine-Ball is a popular game enjoyed by players of all skill levels. In 9 Ball, the shooter must make contact with the lowest numbered ball first. The player who sinks the 9 ball is the winner.

**THE BREAK:**

Balls numbered 1 through 9 are racked in a "diamond" shape with the 1 Ball at the top of the diamond and on the foot spot and the 9 Ball in the center. See the illustration. The cue ball must be placed

behind the head string and the shooter must make contact with the 1 Ball first and either: (a) pockets a ball, or (b) drives four balls to the rails. If the shooter fails to make a legal break, the opponent has the option of accepting the balls in this position or re-racking the balls and shooting the opening break again. If the cue ball is scratched on the break, the incoming player may not play a "Push Out" (see PUSH OUT), but places the "cue ball in hand" anywhere on the table.

**PLAYING THE GAME:**

After the break, the next shot may be played as a "Push Out", or, if the breaker pockets one or more balls, he continues to shoot until he misses, fouls, or wins the game. Once a player misses or fouls, the

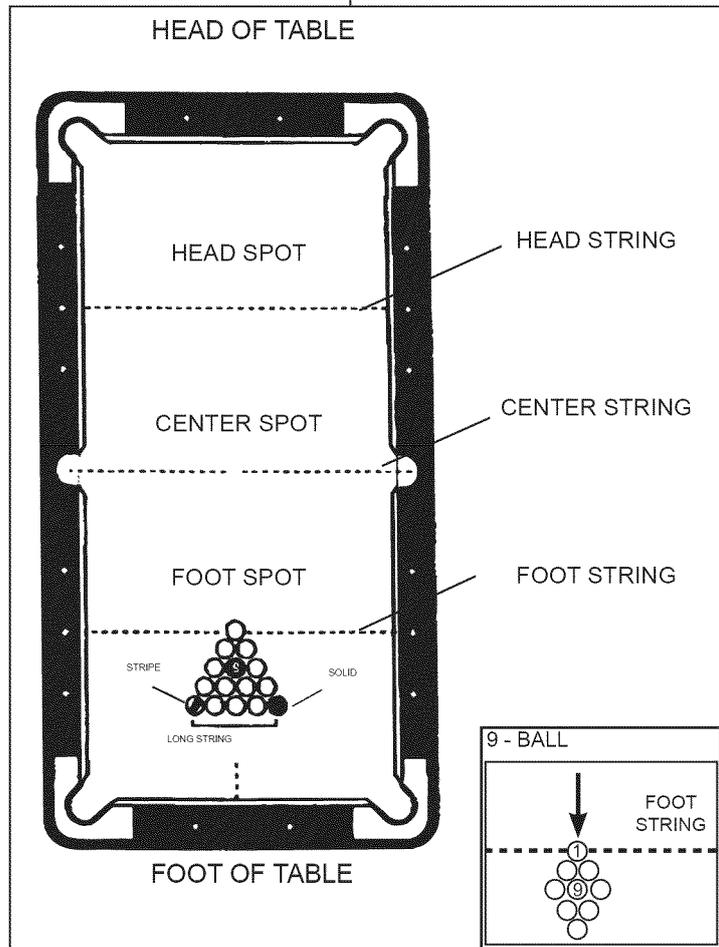

opponent begins to shoot until missing, committing a foul, or winning. The game ends when the 9 Ball is pocketed on a legal shot.

**PUSH OUT:**

The player shooting immediately following a legal break may play a Push Out in an attempt to move the cue ball into a better position. In a Push Out, a ball does not have to make contact with any ball or rail and is not considered a foul unless other foul rules apply. The player must announce the intention of playing a Push Out before the shot, or it is considered normal play. Any ball pocketed on a Push Out does not count and remains pocketed (except the 9 Ball). Following a Push Out, the incoming player: a) must shoot from that position or b) may pass the shot back to the other player.

**FOULS:**

1. Failure to execute a legal shot as defined above.
2. Failure to make first contact with the lowest numbered ball on the table.
3. A scratch shot (shooting the cue ball into a pocket or off the table).
4. Moving or touching any ball by means other than legal play.
5. When the object ball is not pocketed, failure to drive the any ball to a rail after the cue ball has made contact with the object ball.
6. Shooting an intentional jump shot over another ball by scooping the cue stick under the cue ball. A jump shot executed by striking the cue ball above center is legal.
7. Driving any ball off of the table. The object balls are not re-spotted (except the 9 Ball).

**FOUL PENALTY:**

Opposing player gets "cue ball in hand." This means that the player can place the cue ball anywhere on the table. Balls pocketed on the foul are NOT re-spotted (except the 9 Ball). Any player that commits a foul three consecutive times on three successive shots without making a legal shot in between loses the game.

**SPORTCRAFT**   
Budd Lake, NJ 07828  
[www.sportcraft.com](http://www.sportcraft.com)

Printed in China / Impreso en China / Imprimé en Chine