

WEIDERPRO™

270 L

Model No. 831.15907.0

Serial No. _____

Write the serial number in the space above for reference.

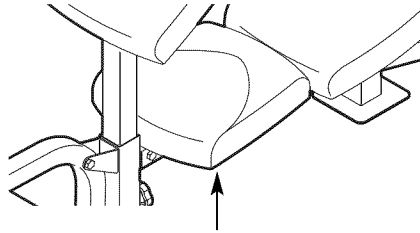

Serial Number Decal
(under the seat)

- Assembly
- Operation
- Maintenance
- Part List and Drawing

Sears, Roebuck and Co.
Hoffman Estates, IL 60179

⚠ CAUTION

Read all precautions and instructions in this manual before using this equipment. Keep this manual for future reference.

WEIGHT BENCH EXERCISER

User's Manual

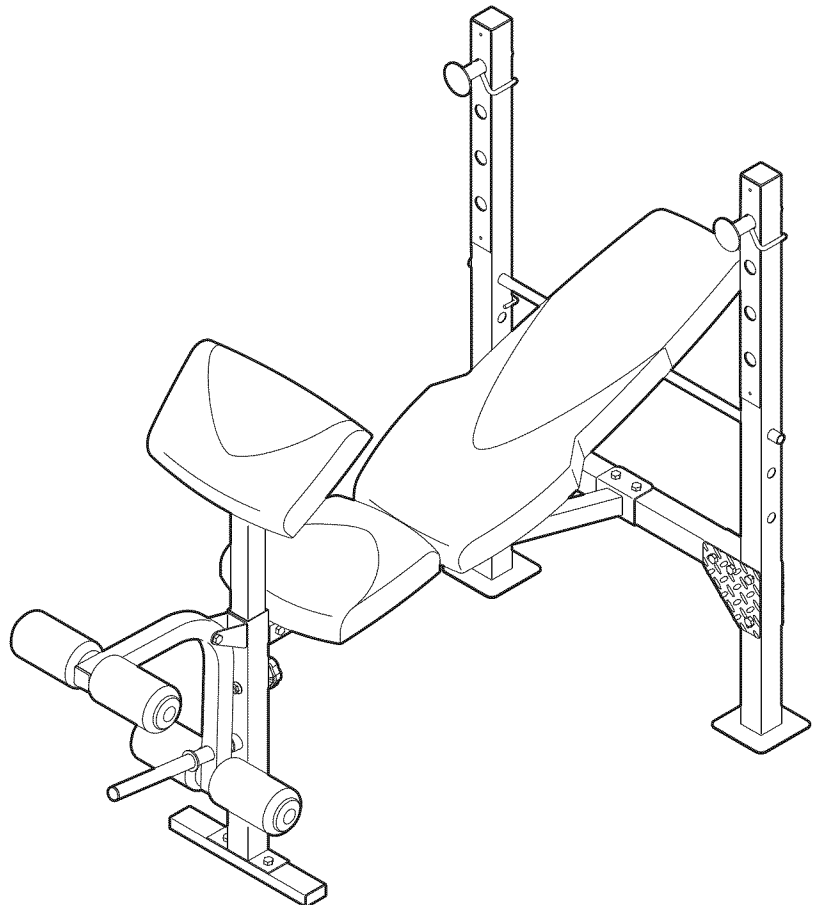

TABLE OF CONTENTS

WARNING DECAL PLACEMENT2

IMPORTANT PRECAUTIONS3

BEFORE YOU BEGIN4

PART IDENTIFICATION CHART5

ASSEMBLY6

ADJUSTMENT11

EXERCISE GUIDELINES13

PART LIST14

EXPLODED DRAWING15

ORDERING REPLACEMENT PARTSBack Cover

90 DAY FULL WARRANTYBack Cover

WARNING DECAL PLACEMENT

This drawing shows the location(s) of the warning decal(s). If a decal is missing or illegible, call 1-877-992-5999 and request a free replacement decal. Apply the decal in the location shown. Note: The decal(s) may not be shown at actual size.

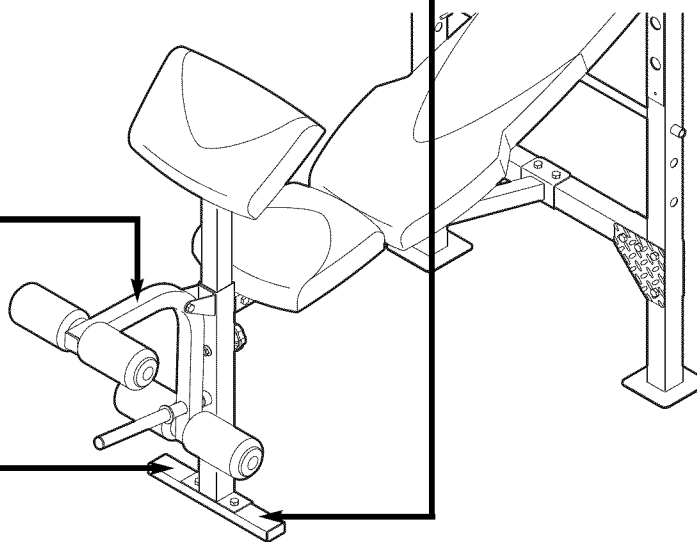
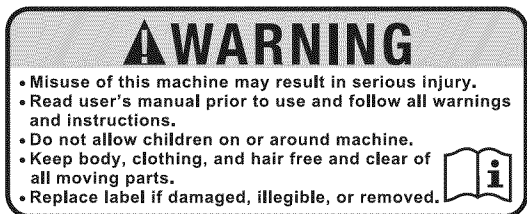

IMPORTANT PRECAUTIONS

⚠ WARNING: To reduce the risk of serious injury, read all important precautions and instructions in this manual and all warnings on your weight bench before using your weight bench. Sears assumes no responsibility for personal injury or property damage sustained by or through the use of this product.

1. Before beginning any exercise program, consult your physician. This is especially important for persons over age 35 or persons with pre-existing health problems.
2. It is the responsibility of the owner to ensure that all users of the weight bench are adequately informed of all precautions.
3. The weight bench is intended for home use only. Do not use the weight bench in a commercial, rental, or institutional setting.
4. Keep the weight bench indoors, away from moisture and dust. Place the weight bench on a level surface, with a mat beneath it to protect the floor or carpet. Make sure that there is enough clearance around the weight bench to mount, dismount, and use the weight bench.
5. Inspect and properly tighten all parts regularly. Replace any worn parts immediately.
6. The weight bench is designed to support a maximum user weight of 300 lbs. (136 kg) and a maximum total weight of 410 lbs. (186 kg). Do not place more than 110 lbs. (50 kg), including a barbell and weights, on the weight rests. Do not place more than 50 lbs. (23 kg) on the leg lever. Note: The weight bench does not include a barbell or weights.
7. Always keep children under age 12 and pets away from the weight bench.
8. Always keep hands and feet away from moving parts.
9. Wear appropriate clothes while exercising; do not wear loose clothes that could become caught on the weight bench. Always wear athletic shoes for foot protection.
10. Do not use a barbell that is longer than 6 ft. (1.8 m) with the weight bench.
11. Always place the same amount of weight on both ends of your barbell. Always keep some weight on both ends of the barbell while adding or removing weights to prevent the barbell from tipping.
12. Before using the leg lever, place a barbell with the same amount of weight on the weight rests to balance the weight bench.
13. Always exercise with a partner. When you are performing bench press exercises, your partner should stand behind you to catch the barbell if you cannot complete a repetition.
14. Before using the backrest in the level position or in an inclined position, make sure that the backrest support is properly inserted (see ADJUSTING THE BACKREST on page 11).
15. Over exercising may result in serious injury or death. If you feel faint or if you experience pain while exercising, stop immediately and cool down.
16. Use the weight bench only as described in this manual.

BEFORE YOU BEGIN

Thank you for selecting the new WEIDER PRO™ 270 L weight bench. The 270 L weight bench offers a selection of exercises designed to develop the major muscle groups of the body. Whether your goal is to tone your body, build dramatic muscle size and strength, or improve your cardiovascular system, the weight bench will help you to achieve the specific results you want.

For your benefit, read this manual carefully before using the weight bench. If you have questions after

reading this manual, please see the back cover of this manual. To help us assist you, note the product model number and serial number before contacting us. The model number and the location of the serial number decal are shown on the front cover of this manual.

Before reading further, please look at the drawing below and familiarize yourself with the parts that are labeled.

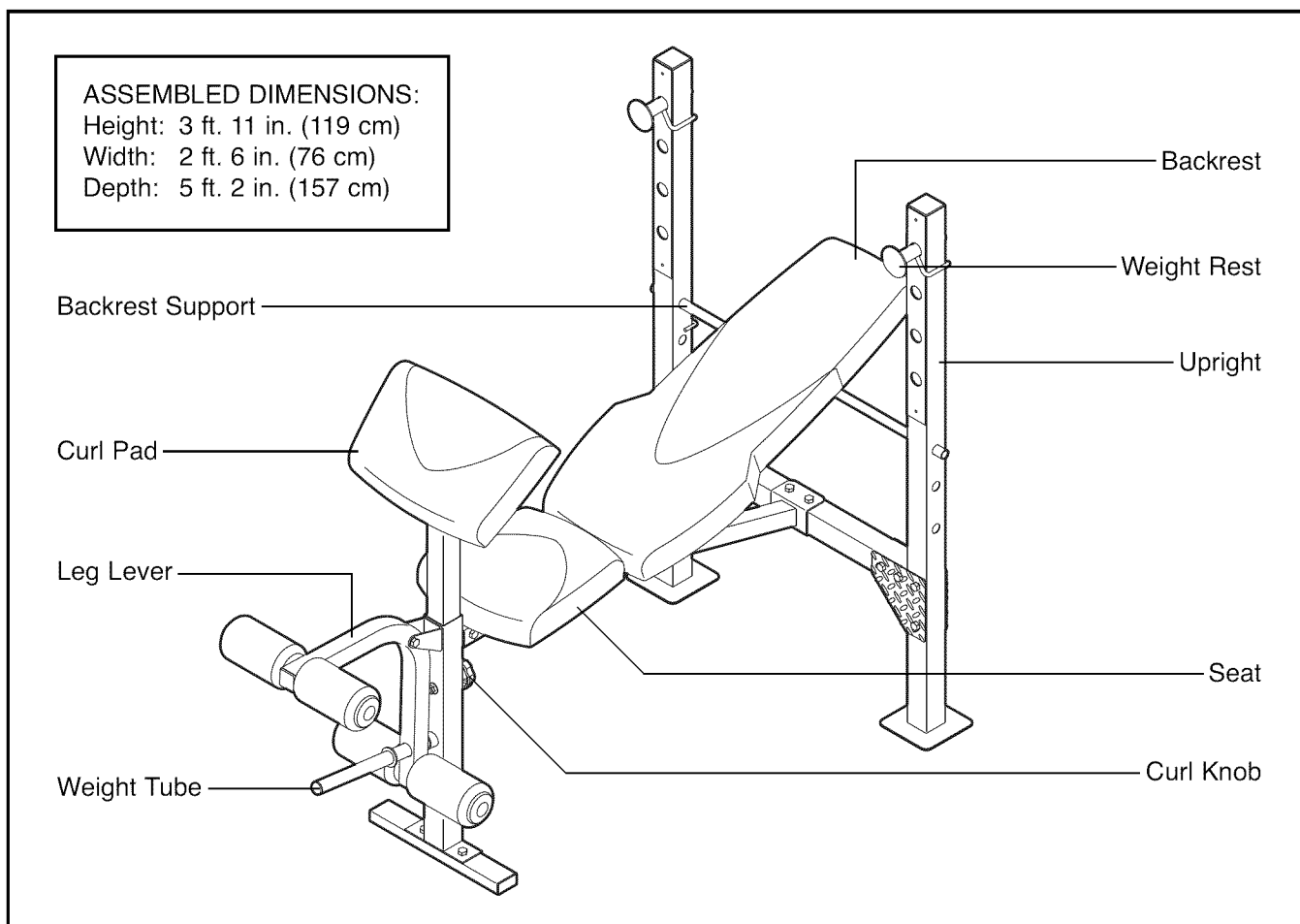

PART IDENTIFICATION CHART

Refer to the drawings below to identify small parts used in assembly. The number in parentheses by each drawing is the key number of the part, from the PART LIST near the end of this manual. **IMPORTANT: If you cannot find a part in the hardware kit, check to see if it has been preassembled. If a part is missing, please call 1-877-992-5999. To avoid damaging parts, do not use power tools for assembly.**

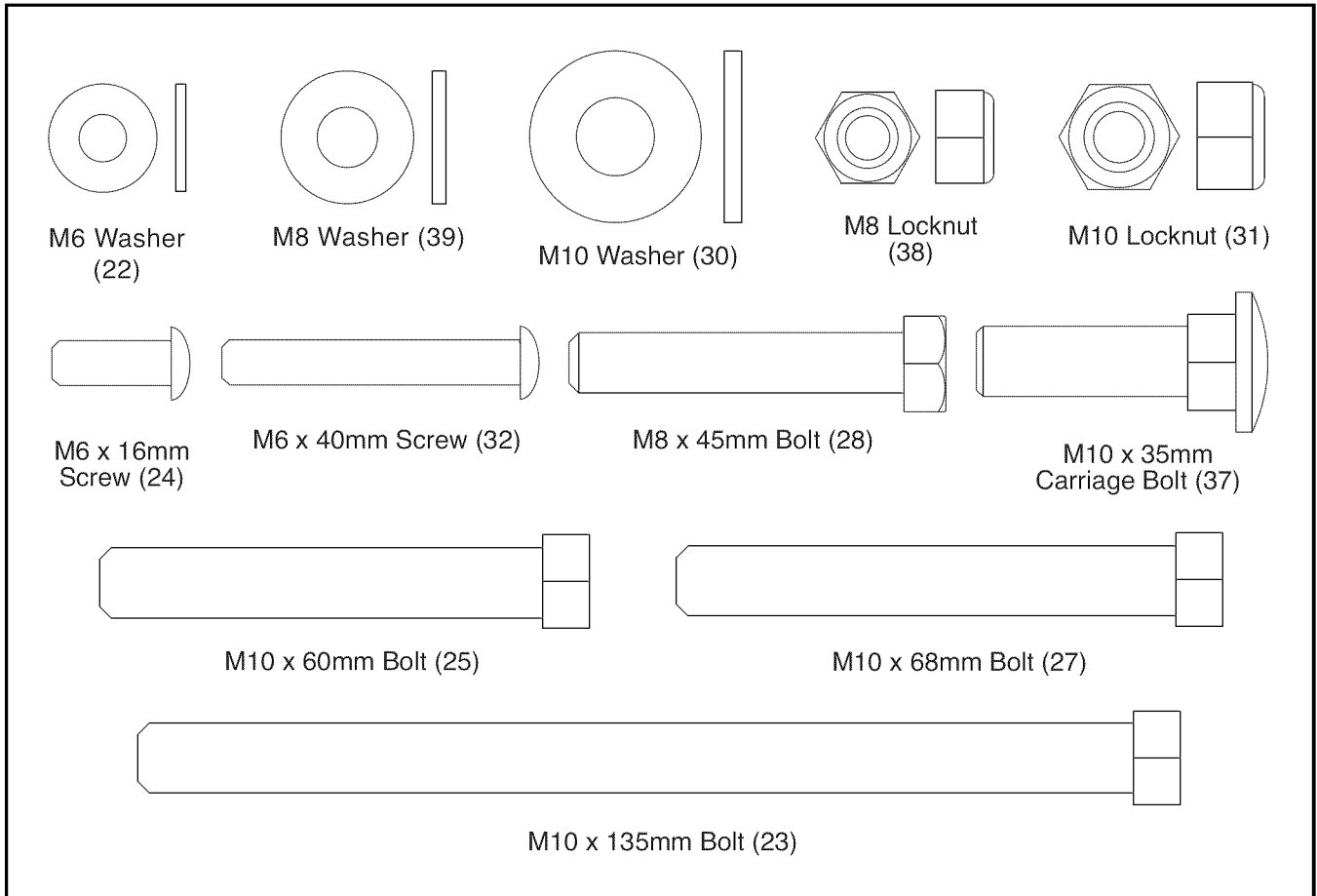

ASSEMBLY

- Assembly requires two persons.
- Because of its size and weight, assemble the weight bench in the location where it will be used. Make sure that there is enough clearance to walk around the weight bench as you assemble it.
- Place all parts in a cleared area and remove the packing materials. Do not dispose of the packing materials until you complete all assembly steps.
- To identify small parts, see page 5.

- The following tools (not included) may be required for assembly:

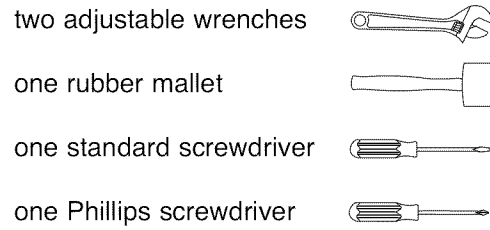

Assembly will be more convenient if you have a socket set, a set of open-end or closed-end wrenches, or a set of ratchet wrenches.

1. **To make assembly easier, read the assembly tips at the top of this page before beginning.**

Orient one of the Uprights (1) so that the Upright Cover (10) is on the side shown.

Next, identify one Joint Plate A (35) and one Joint Plate B (41); the Joint Plates have "A" and "B" stickers. Orient the Joint Plates as shown, with the diamond patterns facing away from the Upright (1).

Attach the Joint Plates (35, 41) to the Upright (1) with two M10 x 68mm Bolts (27) and two M10 Locknuts (31). **Do not tighten the Locknuts yet.**

Orient the other Upright (1) and the other Joint Plates (35, 41) as shown; attach the Joint Plates as described above.

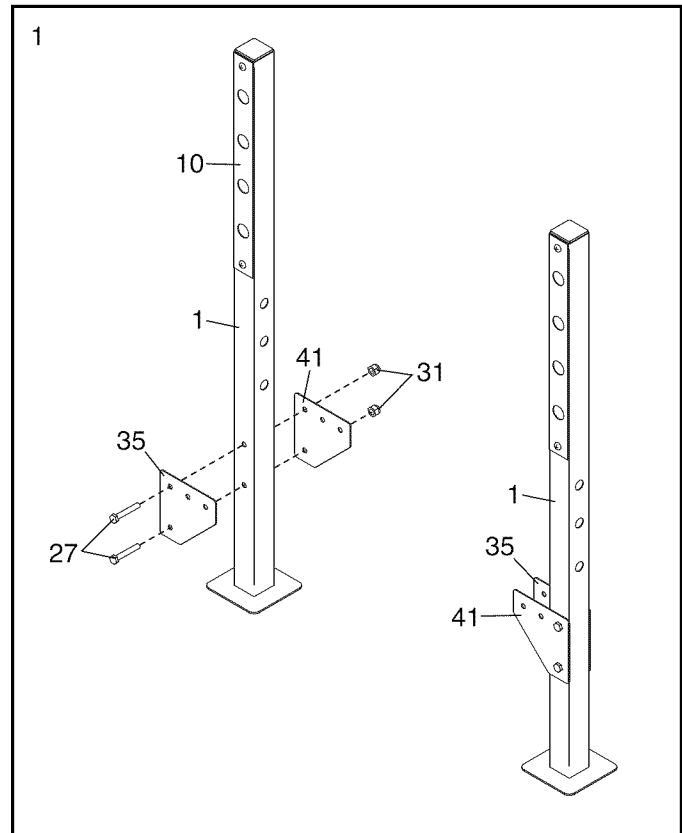

2. Attach one end of the Crossbar (2) to two Joint Plates (35, 41) with two M10 x 68mm Bolts (27) and two M10 Locknuts (31). **Do not tighten the Locknuts yet.**

Attach the other end of the Crossbar (2) in the same way.

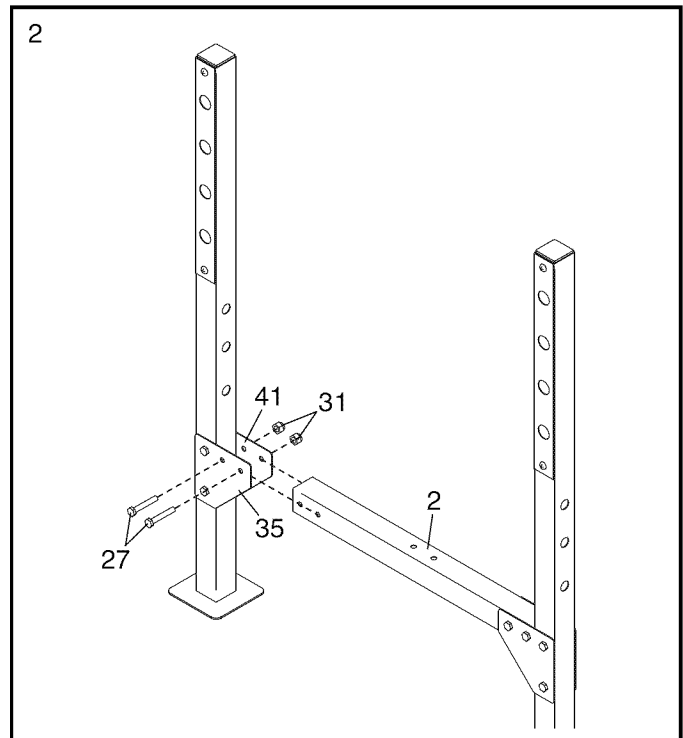

3. Orient the Base (33) so that the warning decals are in the positions shown.

Attach the Base (33) to the Front Leg (4) with two M10 x 35mm Carriage Bolts (37) and two M10 Locknuts (31).

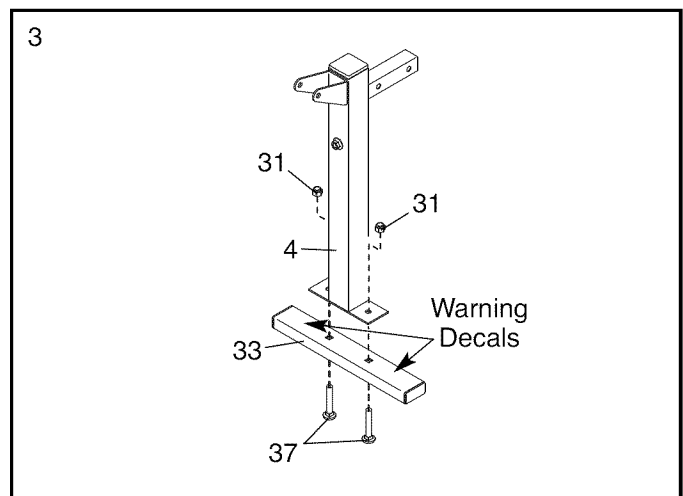

4. Attach the Front Leg (4) to the Frame (3) with two M8 x 45mm Bolts (28), two M8 Washers (39), and two M8 Locknuts (38). **Make sure that the Locknuts are in the indicated hexagonal holes; do not tighten the Bolts yet.**

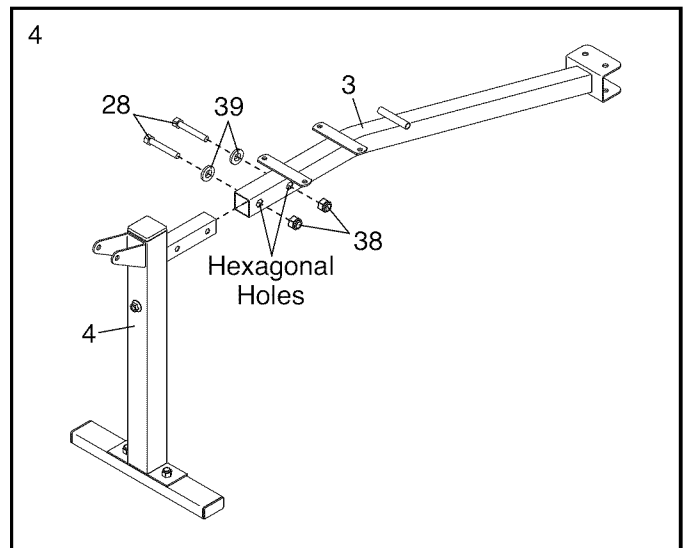

5. Attach the Frame (3) to the Crossbar (2) with two M10 x 68mm Bolts (27) and two M10 Locknuts (31). **Do not tighten the Locknuts yet.**

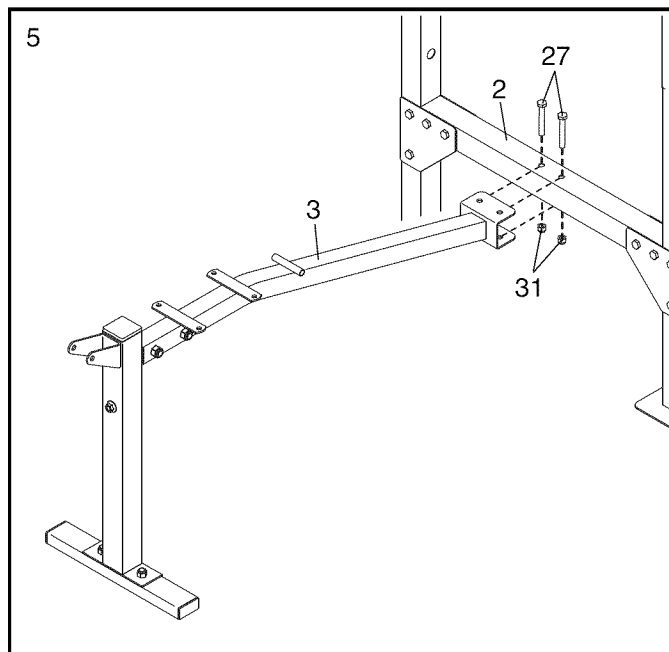

6. Insert the Backrest Support (14) from the direction shown into one of the three sets of holes in the Uprights (1). **Rotate the Backrest Support so that the locking pin is wrapped around the Upright (see the inset drawing).**

See steps 1, 2, and 5. Tighten the M10 Locknuts (31).

See step 4. Tighten the M8 x 45mm Bolts (28).

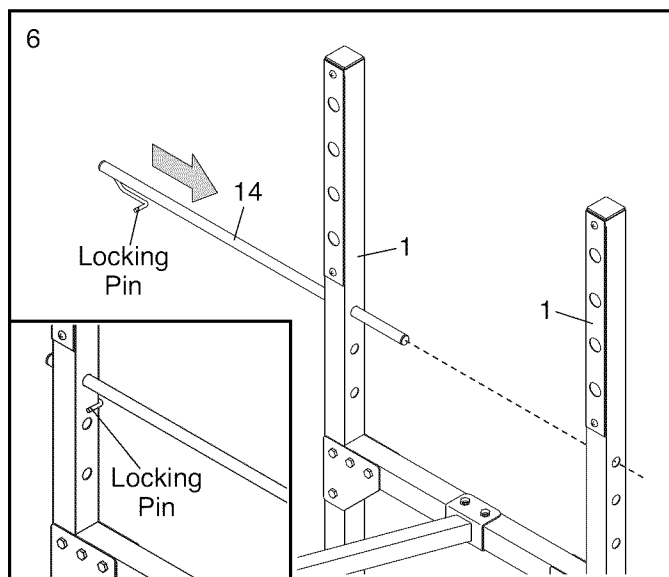

7. Apply a small amount of the included grease to an M10 x 60mm Bolt (25).

Attach the Leg Lever (6) to the Front Leg (4) with the M10 x 60mm Bolt (25) and an M10 Locknut (31). **Do not overtighten the Locknut; the Leg Lever must pivot easily.**

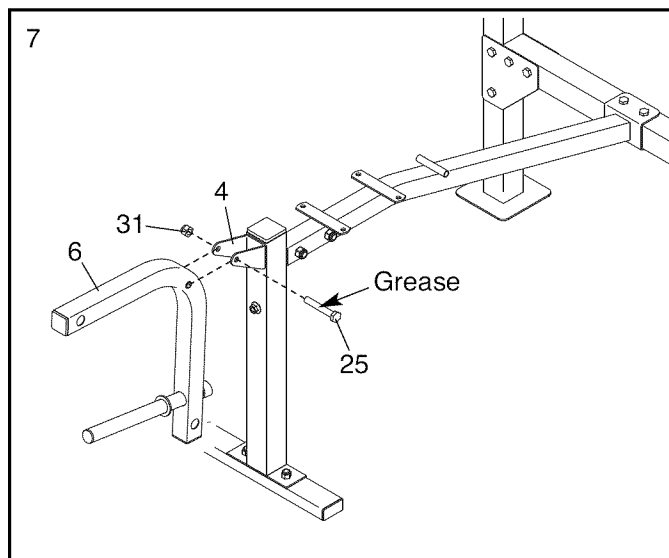

8. Insert a Pad Tube (12) through the Leg Lever (6).

Slide a Foam Pad (13) onto each end of the Pad Tube (12).

Press a Pad Cap (34) into each end of the Pad Tube (12).

Repeat this step with the other Pad Tube (12), Foam Pads (13), and Pad Caps (34).

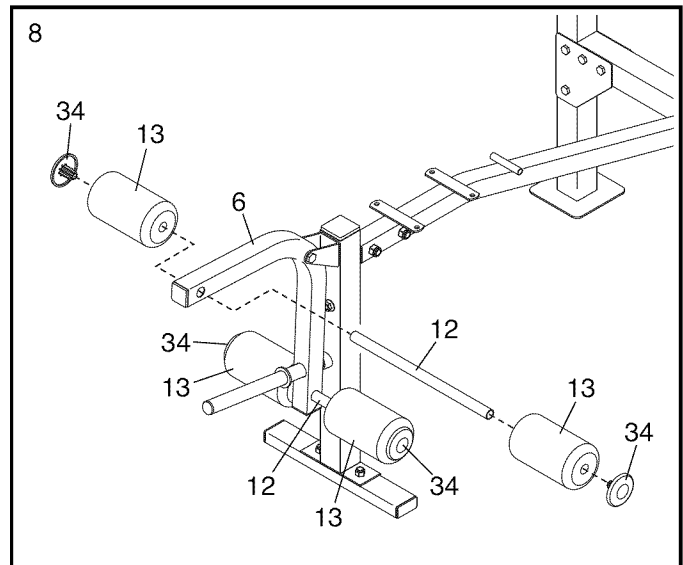

9. Insert a Weight Rest (15) into an Upright (1). Rotate the Weight Rest so that the locking pin is wrapped around the Upright.

Repeat this step with the other Weight Rest (15). Make sure that both Weight Rests are at the same height.

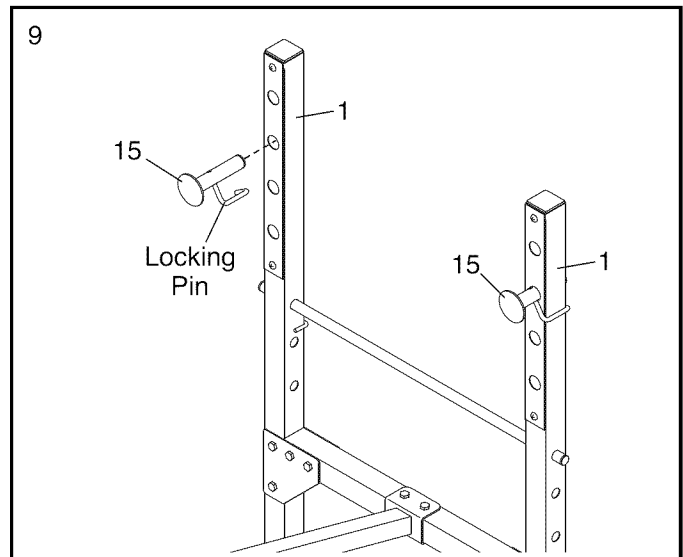

10. Orient the Backrest Tubes (7) so that the indicated holes are in the position shown.

Attach the Backrest Tubes (7) to the Backrest (8) with four M6 x 40mm Screws (32) and four M6 Washers (22). **Do not tighten the Screws yet.**

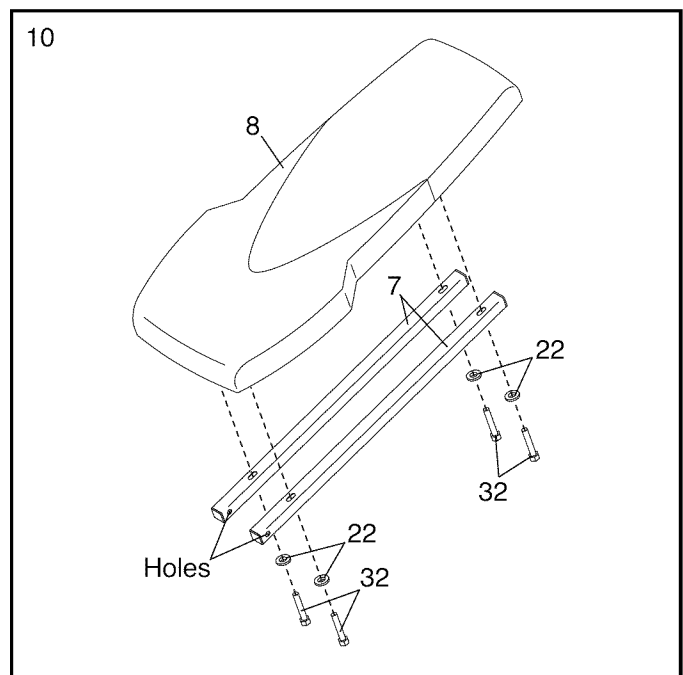

11. Apply grease to an M10 x 135mm Bolt (23).

Attach the Backrest Tubes (7) to the welded tube on the Frame (3) with the M10 x 135mm Bolt (23), two M10 Washers (30), and an M10 Locknut (31). **Do not overtighten the Locknut; the Backrest Tubes must pivot easily.**

See step 10. Tighten the M6 x 40mm Screws (32).

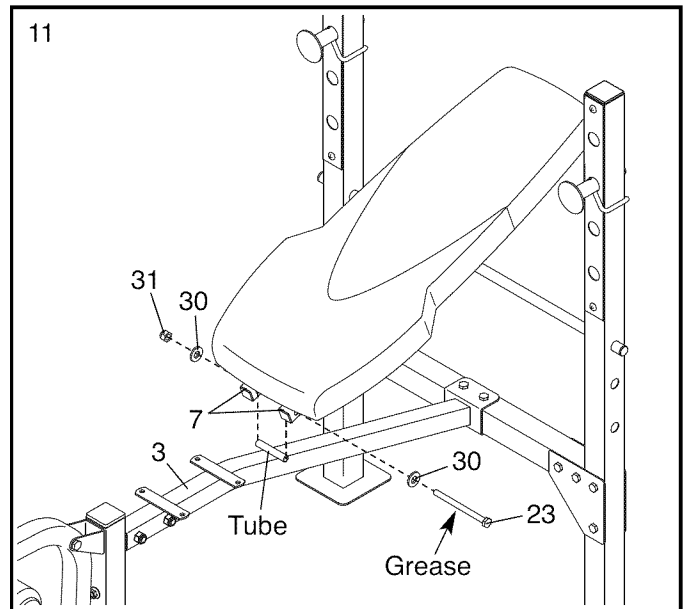

12. Orient the Seat (9) as shown.

Attach the Seat (9) to the Frame (3) with four M6 x 16mm Screws (24).

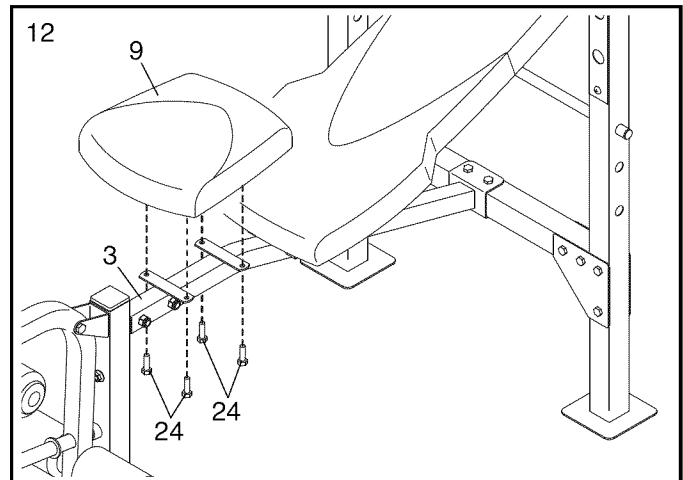

13. Orient the Curl Pad (5) as shown.

Attach the Curl Pad (5) to the Curl Post (11) with two M6 x 16mm Screws (24).

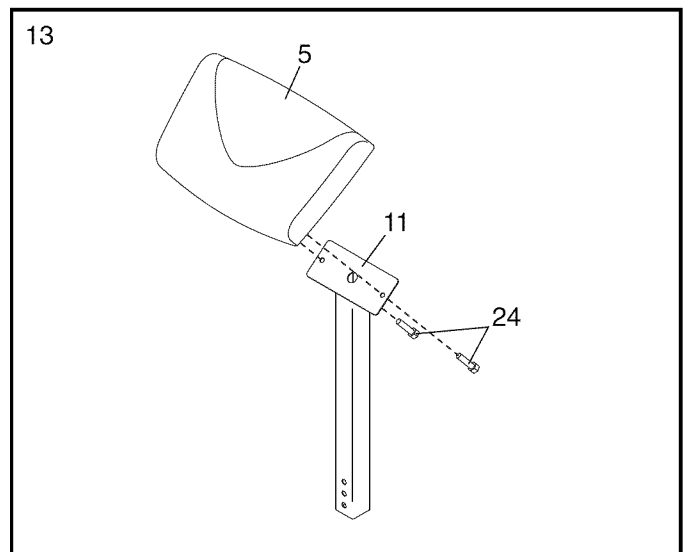

14. **Make sure that all parts are properly tightened before you use the weight bench.** The use of all remaining parts will be explained in ADJUSTMENT, beginning on page 11.

ADJUSTMENT

The weight bench is designed to be used with your own weight set (not included). The steps below explain how the weight bench can be adjusted. See EXERCISE GUIDELINES on page 13 for important exercise information, and refer to the accompanying exercise guide to see the correct form for several exercises. Refer also to the exercise information accompanying your weight set for additional exercises.

Make sure that all parts are properly tightened each time the weight bench is used. Replace any worn parts immediately. The weight bench can be cleaned with a damp cloth and a mild, non-abrasive detergent; **do not use solvents to clean the weight bench.**

ADJUSTING THE BACKREST

The Backrest (8) can be used in a declined position, a level position, or either of two inclined positions.

To use the Backrest (8) in the declined position, remove the Backrest Support (14) and lay the Backrest on the Crossbar (2).

To use the Backrest (8) in the level position or in an inclined position, lift the Backrest and insert the Backrest Support (14) from the direction shown into one of the three sets of holes in the Uprights (1). **Rotate the Backrest Support so that the locking pin is wrapped around the Upright.**

⚠ WARNING: When using the Backrest (8) in a level position or in an inclined position, insert the Backrest Support (14) completely through both Uprights (1) and turn it to the locked position.

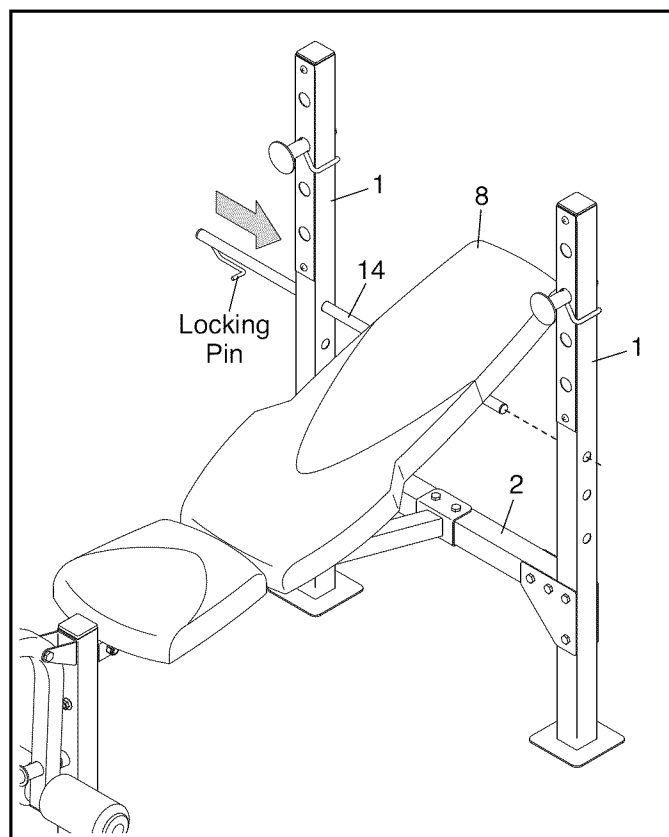

ATTACHING WEIGHTS TO THE LEG LEVER

To use the Leg Lever (6), slide the desired weights (not included) onto the weight tube.

⚠ WARNING: Do not place more than 50 lbs. (23 kg) on the Leg Lever (6).

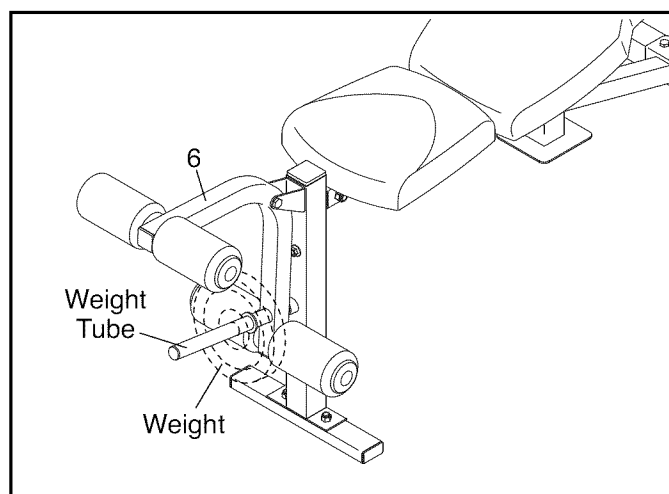

ADJUSTING THE WEIGHT RESTS

To change the height of the Weight Rests (15), remove them from the Uprights (1) and insert them into a different set of holes in the Uprights. **Rotate the Weight Rests so that the locking pins are wrapped around the Uprights.**

⚠ WARNING: Always set both Weight Rests (15) at the same height. Always rotate the Weight Rests so that the locking pins are wrapped around the Uprights (1).

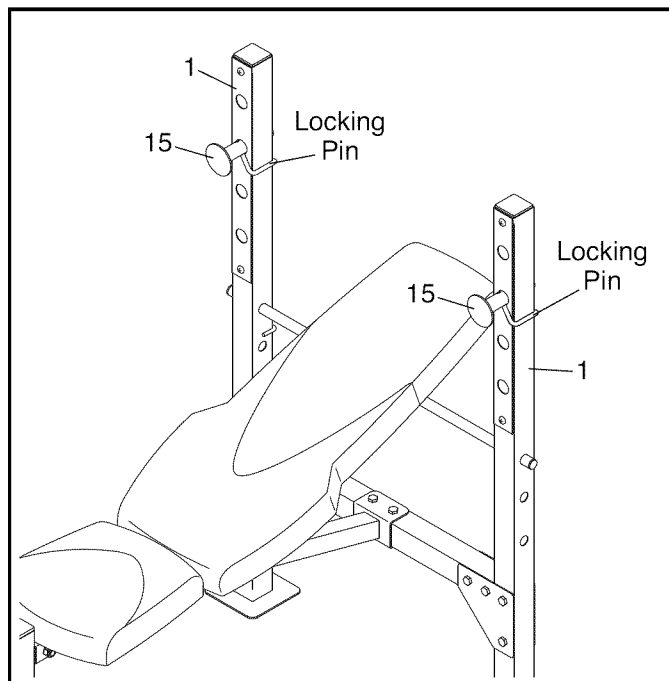

USING THE CURL PAD

To use the Curl Pad (5), first remove the 50mm Square Inner Cap (16) from the Front Leg (4).

Next, insert the Curl Post (11) into the Front Leg (4), and tighten the Curl Knob (36) into the Front Leg and into one of the adjustment holes in the Curl Post. **Make sure that the Curl Knob is in one of the holes in the Curl Post.**

Note: When you are not using the Curl Pad (5), remove the Curl Post (11) and insert the 50mm Square Inner Cap (16) into the Front Leg (4).

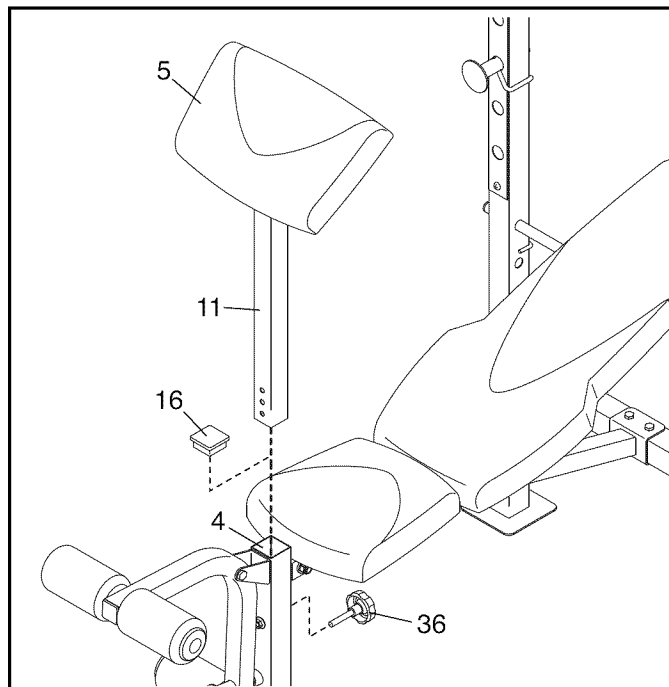

EXERCISE GUIDELINES

FOUR TYPES OF STRENGTH WORKOUTS

Note: A “repetition” is one complete cycle of an exercise, such as one sit-up. A “set” is a series of repetitions.

Muscle Building—Work your muscles near their maximum capacity and progressively increase the intensity of your exercise. Adjust the intensity level of an individual exercise as follows:

- Change the amount of resistance used.
- Change the number of repetitions or sets performed.

Use your own judgment to determine the amount of resistance that is right for you. Begin with 3 sets of 8 repetitions for each exercise that you perform. Rest for 3 minutes after each set. When you can complete 3 sets of 12 repetitions without difficulty, increase the amount of resistance.

Toning—Tone your muscles by working them to a moderate percentage of their capacity. Select a moderate amount of resistance and increase the number of repetitions in each set. Complete as many sets of 15 to 20 repetitions as possible without discomfort. Rest for 1 minute after each set. Work your muscles by completing more sets rather than by using high amounts of resistance.

Weight Loss—To lose weight, use a low amount of resistance and increase the number of repetitions in each set. Exercise for 20 to 30 minutes, resting for a maximum of 30 seconds between sets.

Cross Training—Combine strength training and aerobic exercise by following this type of program:

- Strength workouts on Monday, Wednesday, and Friday.
- 20 to 30 minutes of aerobic exercise on Tuesday and Thursday.
- One full day of rest each week to give your body time to regenerate.

WORKOUT GUIDELINES

Familiarize yourself with the equipment and learn the proper form for each exercise. Use your own judgment

to determine the appropriate length of time for each workout, and the numbers of repetitions and sets to complete. Progress at your own pace and be sensitive to your body’s signals. Follow each strength workout with at least one day of rest.

Warming Up—Start with 5 to 10 minutes of stretching and light exercise. A warm-up increases your body temperature, heart rate, and circulation in preparation for exercise.

Working Out—Include 6 to 10 different exercises in each workout. Select exercises for every major muscle group, emphasizing areas that you want to develop. To give balance and variety to your workouts, vary the exercises from workout to workout.

Cooling Down—Finish with 5 to 10 minutes of stretching. Stretching increases the flexibility of your muscles and helps to prevent post-exercise problems.

EXERCISE FORM

Move through the full range of motion for each exercise and move only the appropriate parts of the body. Perform the repetitions in each set smoothly and without pausing. The exertion stage of each repetition should last about half as long as the return stage. Exhale during the exertion stage of each repetition and inhale during the return stroke. Never hold your breath.

Rest for a short period of time after each set:

- Muscle Building—Rest for three minutes after each set.
- Toning—Rest for one minute after each set.
- Weight Loss—Rest for 30 seconds after each set.

STAYING MOTIVATED

For motivation, keep a record of each workout. Write the date, the exercises performed, the resistance used, and the numbers of sets and repetitions completed. Record your weight and key body measurements once a month. To achieve good results, make exercise a regular and enjoyable part of your life.

PART LIST—Model No. 831.15907.0

R0610A

Key No.	Qty.	Description	Key No.	Qty.	Description
1	2	Upright	23	1	M10 x 135mm Bolt
2	1	Crossbar	24	6	M6 x 16mm Screw
3	1	Frame	25	1	M10 x 60mm Bolt
4	1	Front Leg	26	2	25mm x 50mm Inner Cap
5	1	Curl Pad	27	10	M10 x 68mm Bolt
6	1	Leg Lever	28	2	M8 x 45mm Bolt
7	2	Backrest Tube	29	4	M4 x 16mm Screw
8	1	Backrest	30	2	M10 Washer
9	1	Seat	31	14	M10 Locknut
10	2	Upright Cover	32	4	M6 x 40mm Screw
11	1	Curl Post	33	1	Base
12	2	Pad Tube	34	4	Pad Cap
13	4	Foam Pad	35	2	Joint Plate A
14	1	Backrest Support	36	1	Curl Knob
15	2	Weight Rest	37	2	M10 x 35mm Carriage Bolt
16	3	50mm Square Inner Cap	38	2	M8 Locknut
17	1	25mm Round Angled Cap	39	2	M8 Washer
18	2	38mm Square Inner Cap	40	1	25mm x 2mm Round Inner Cap
19	4	25mm Square Inner Cap	41	2	Joint Plate B
20	2	25mm x 2.5mm Round Inner Cap	*	—	User's Manual
21	2	21mm Round Inner Cap	*	—	Exercise Guide
22	4	M6 Washer	*	—	Grease Packet

Note: Specifications are subject to change without notice. For information about ordering replacement parts, see the back cover of this manual. *These parts are not illustrated. **If a part is missing, please call 1-877-992-5999.**

EXPLODED DRAWING—Model No. 831.15907.0

R0610A

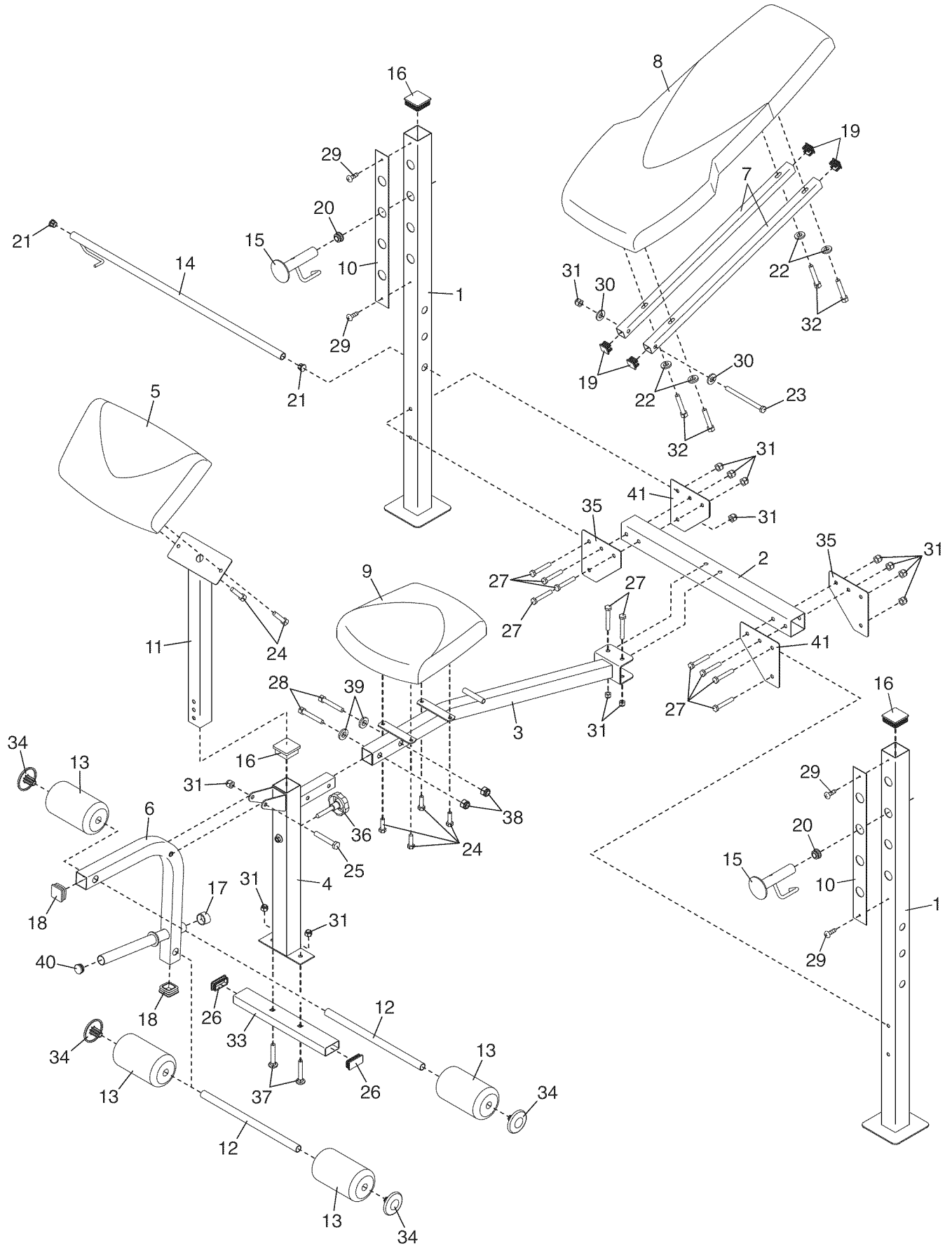

Get it fixed, at your home or ours!

Your Home

For repair—**in your home**—of **all** major brand appliances, lawn and garden equipment, or heating and cooling systems, **no matter who made it, no matter who sold it!**

For the replacement parts, accessories, and user's manuals that you need to do-it-yourself.

For Sears professional installation of home appliances and items like garage door openers and water heaters.

1-800-4-MY-HOME® (1-800-469-4663)

Call anytime, day or night (U.S.A. and Canada)

www.sears.com

www.sears.ca

Our Home

For repair of carry-in items like vacuums, lawn equipment, and electronics, call or go on-line for the location of your nearest **Sears Parts & Repair Center.**

1-800-488-1222 Call anytime, day or night (U.S.A. only)

www.sears.com

To purchase a protection agreement (U.S.A.) or maintenance agreement (Canada) on a product serviced by Sears:

1-800-827-6655 (U.S.A.)

1-800-361-6665 (Canada)

Para pedir servicio de reparación a domicilio, y para ordenar piezas:

1-888-SU-HOGAR® (1-888-784-6427)



® Registered Trademark / ™ Trademark / ™ Service Mark of Sears Brands, LLC
© Marca Registrada / ™ Marca de Fábrica / ™ Marca de Servicio de Sears Brands, LLC

90 DAY FULL WARRANTY

If this Weight Bench Exerciser fails due to a defect in material or workmanship within 90 days of the date of purchase, call 1-800-4-MY-HOME® (1-800-469-4663) to arrange for free repair (or replacement if repair proves impossible).

This warranty does not apply when the Weight Bench Exerciser is used commercially or for rental purposes.

This warranty gives you specific legal rights, and you may also have other rights which vary from state to state.

Sears, Roebuck and Co., Hoffman Estates, IL 60179