

42 " MOWER DECK GAUGE WHEEL KIT

Model No. 917.242931

INSTALLATION INSTRUCTIONS

Kit Contains:

- (1) Gauge Wheel Bracket R.H.
- (1) Gauge Wheel Bracket L.H.
- (2) Gauge Wheels
- (*) Mounting Hardware

PREPARE MOWER DECK (See Fig. 1)

- Remove and discard the two (2) carriage bolts and nuts from top of mower deck where gauge wheel brackets are to be assembled.

ATTACH GAUGE WHEEL BRACKETS

(See Fig. 2)

- Place L.H. gauge wheel mounting bracket to the inside of the deck housing tab.
- Assemble carriage bolt and locknut as shown. Do not tighten at this time. **NOTE:** Carriage bolt head is to underside of mower deck housing.
- Assemble (2) two hex bolts and locknuts as shown.
- Tighten all hardware securely.
- Repeat for R.H. gauge wheel mounting bracket.

ASSEMBLE GAUGE WHEELS TO MOWER DECK (See Fig. 3)

The gauge wheels are designed to keep the mower deck in proper position when operating mower. Be sure they are properly adjusted to ensure optimum mower performance.

- Assemble gauge wheels with tractor on a flat level surface.
- Adjust mower to desired cutting height (See your tractor owner's manual).
- With mower in desired height of cut position, gauge wheels should be assembled so they are slightly off the ground. Install gauge wheel in appropriate hole with shoulder bolt, 3/8 washer, and 3/8-16 locknut and tighten securely.
- Repeat for opposite side installing gauge wheel in same adjustment hole.

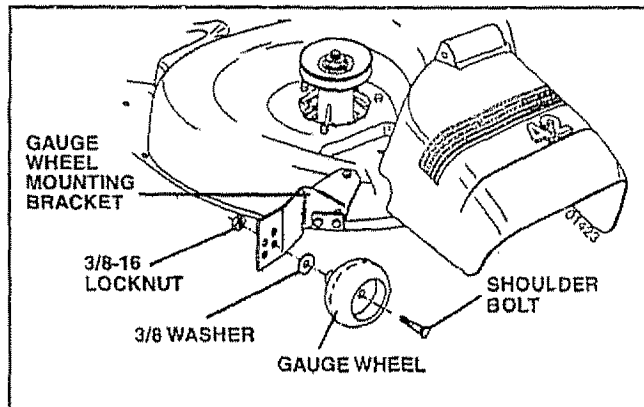
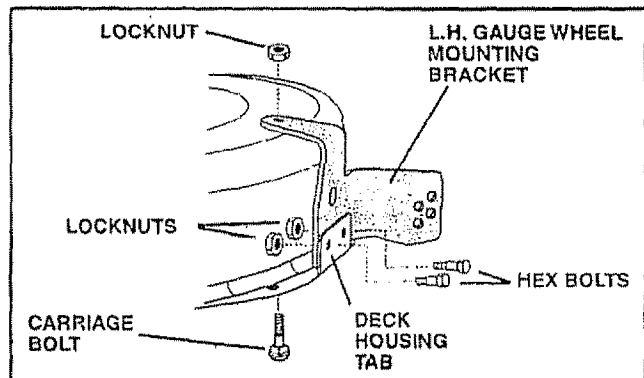
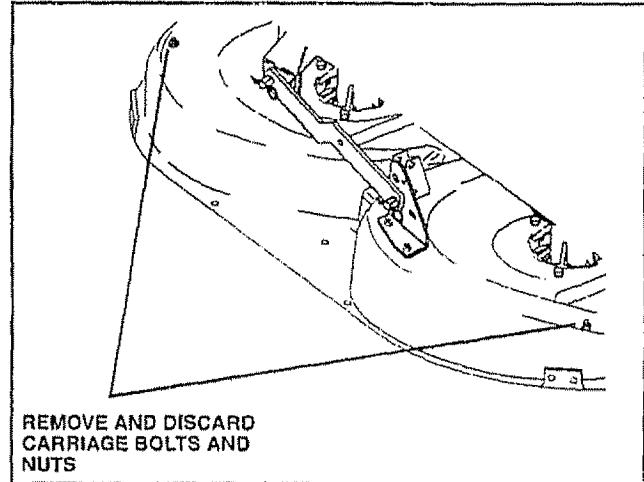

REPAIR PARTS

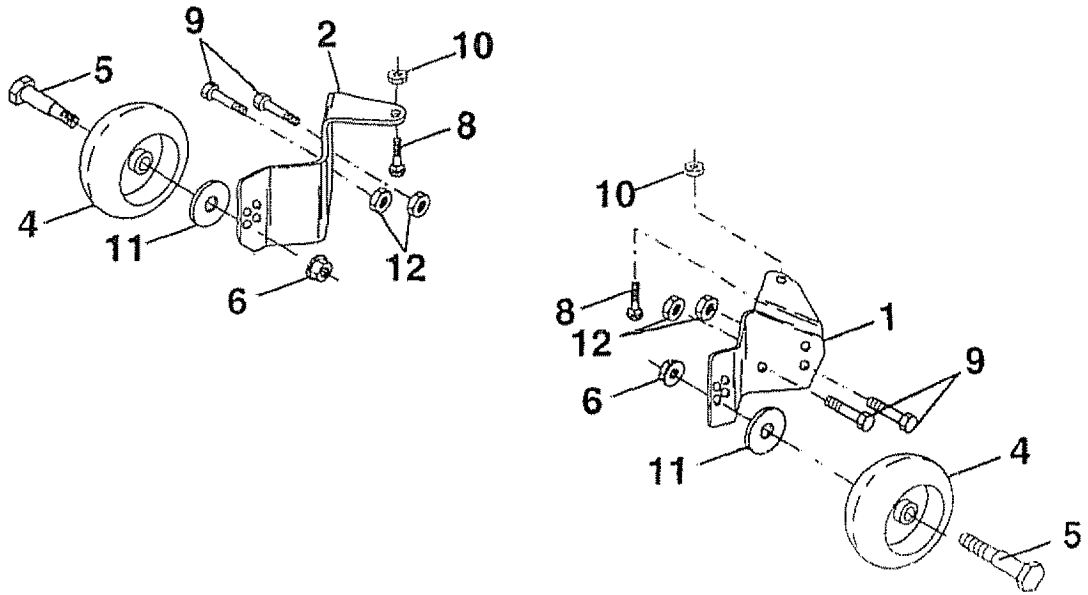

- | | | |
|----|-----------|---------------------------|
| 1 | 179293 | Bracket, Gage Wheel R.H. |
| 2 | 179292 | Bracket, Gage Wheel L.H. |
| 4 | 174873 | Wheel, Gage |
| 5 | 184219 | Bolt, Shoulder |
| 6 | STD541437 | Locknut 3/8" |
| 8 | 72110505 | Bolt, Carr.5/16-18 x 5/8" |
| 9 | STD522107 | Screw 1/4-20 x 3/4" |
| 10 | STD541431 | Locknut 5/16 |
| 11 | 19121414 | Washer 3/8 |
| 12 | STD541425 | Locknut 1/4-20 |