

# OPERATOR'S MANUAL

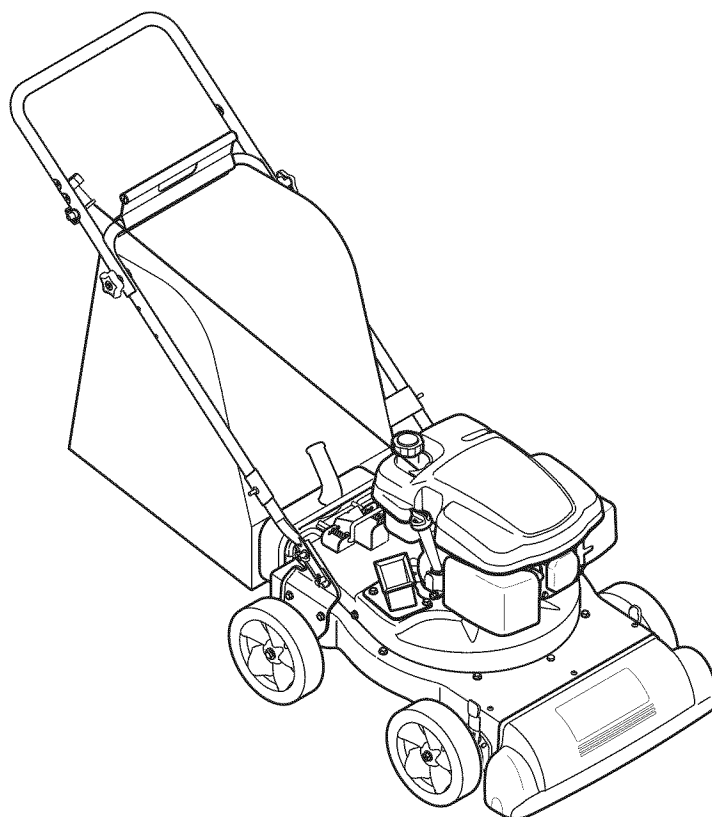

## Chipper/Shredder Vacuum Model CSV 020

### **⚠ WARNING**

**READ AND FOLLOW ALL SAFETY RULES AND INSTRUCTIONS IN THIS MANUAL  
BEFORE ATTEMPTING TO OPERATE THIS MACHINE.  
FAILURE TO COMPLY WITH THESE INSTRUCTIONS MAY RESULT IN PERSONAL INJURY.**

---

MTD LLC, P.O. BOX 361131 CLEVELAND, OHIO 44136-0019

---

## Thank You

Thank you for purchasing a Chipper/Shredder Vacuum manufactured by MTD. It was carefully engineered to provide excellent performance when properly operated and maintained.

Please read this entire manual prior to operating the equipment. It instructs you how to safely and easily set up, operate and maintain your machine. Please be sure that you, and any other persons who will operate the machine, carefully follow the recommended safety practices at all times. Failure to do so could result in personal injury or property damage.

All information in this manual is relative to the most recent product information available at the time of printing. Review this manual frequently to familiarize yourself with the machine, its features and operation. Please be aware that this Operator's Manual may cover a range of product specifications for various models. Characteristics and features discussed and/or illustrated in this manual may not be applicable to all models. We reserve

the right to change product specifications, designs and equipment without notice and without incurring obligation.

If you have any problems or questions concerning the machine, phone your local authorized MTD service dealer or contact us directly. MTD's Customer Support telephone numbers, website address and mailing address can be found on this page. We want to ensure your complete satisfaction at all times.

Throughout this manual, all references to *right* and *left* side of the machine are observed from the operating position

The engine manufacturer is responsible for all engine-related issues with regards to performance, power-rating, specifications, warranty and service. Please refer to the engine manufacturer's Owner's/Operator's Manual, packed separately with your machine, for more information.

---

## Table of Contents

<b>Safe Operation Practices .....</b>	<b>3</b>	<b>Service .....</b>	<b>14</b>
<b>Assembly &amp; Set-Up .....</b>	<b>7</b>	<b>Troubleshooting .....</b>	<b>16</b>
<b>Controls &amp; Features .....</b>	<b>10</b>	<b>Replacement Parts .....</b>	<b>17</b>
<b>Operation .....</b>	<b>11</b>	<b>Warranty .....</b>	<b>20</b>
<b>Maintenance &amp; Adjustment .....</b>	<b>12</b>		

---

## Record Product Information

Before setting up and operating your new equipment, please locate the model plate on the equipment and record the information in the provided area to the right. You can locate the model plate by standing at the operator's position and looking down at the rear of the deck. This information will be necessary, should you seek technical support via our web site, Customer Support Department, or with a local authorized service dealer.

### MODEL NUMBER

--	--	--	--	--	--	--	--	--	--	--	--

### SERIAL NUMBER

--	--	--	--	--	--	--	--	--	--	--	--

---

## Customer Support

*Please do NOT return the machine to the retailer or dealer without first contacting our Customer Support Department.*

If you have difficulty assembling this product or have any questions regarding the controls, operation, or maintenance of this machine, you can seek help from the experts. Choose from the options below:

- ◇ Visit us on the web at [www.mtdproducts.com](http://www.mtdproducts.com)
- ◇ Call a Customer Support Representative at (800) 800-7310 or (330) 220-4683
- ◇ Write us at MTD LLC • P.O. Box 361131 • Cleveland, OH • 44136-0019



**WARNING:** This symbol points out important safety instructions which, if not followed, could endanger the personal safety and/or property of yourself and others. Read and follow all instructions in this manual before attempting to operate this machine. Failure to comply with these instructions may result in personal injury.

When you see this symbol - **HEED ITS WARNING!**

## CALIFORNIA PROPOSITION 65



**WARNING:** Engine Exhaust, some of its constituents, and certain vehicle components contain or emit chemicals known to State of California to cause cancer and birth defects or other reproductive harm.



**DANGER:** This machine was built to be operated according to the safe operation practices in this manual. As with any type of power equipment, carelessness or error on the part of the operator can result in serious injury. This machine is capable of amputating fingers, hands, toes and feet and throwing debris. Failure to observe the following safety instructions could result in serious injury or death.

### Training

1. Read, understand, and follow all instructions on the machine and in the manual(s) before attempting to assemble and operate. Keep this manual in a safe place for future and regular reference and for ordering replacement parts.
2. Be familiar with all controls and their proper operation. Know how to stop the machine and disengage them quickly.
3. Never allow children under 16 years of age to operate this machine. Children 16 and over should read and understand the instructions and safe operation practices in this manual and on the machine and be trained and supervised by an adult.
4. Never allow adults to operate this machine without proper instruction.
5. Keep bystanders, pets, and children at least 75 feet from the machine while it is in operation. Stop machine if anyone enters the area.
6. Never run an engine indoors or in a poorly ventilated area. Engine exhaust contains carbon monoxide, an odorless and deadly gas.
7. Do not put hands and feet near rotating parts or in the feeding chambers and discharge opening. Contact with the rotating impeller can amputate fingers, hands, and feet.

8. Never attempt to unclog either the feed intake or discharge opening, remove or empty bag, or inspect and repair the machine while the engine is running. Shut the engine off and wait until all moving parts have come to a complete stop. Disconnect the spark plug wire and ground it against the engine.

### Preparation

1. Thoroughly inspect the area where the equipment is to be used. Remove all rocks, bottles, cans, or other foreign objects which could be picked up or thrown and cause personal injury or damage to the machine.
2. Always wear safety glasses or safety goggles during operation and while performing an adjustment or repair, to protect your eyes. Thrown objects which ricochet can cause serious injury to the eyes.
3. Wear sturdy, rough-soled work shoes and close-fitting slacks and shirts. Loose fitting clothes or jewelry can be caught in movable parts. Never operate this machine in bare feet or sandals. Wear leather work gloves when feeding material in the chipper chute.
4. Before starting, check all bolts and screws for proper tightness to be sure the machine is in safe working condition. Also, visually inspect machine for any damage at frequent intervals.
5. Maintain or replace safety and instructions labels, as necessary.

## Safe Handling of Gasoline:

To avoid personal injury or property damage use extreme care in handling gasoline. Gasoline is extremely flammable and the vapors are explosive. Serious personal injury can occur when gasoline is spilled on yourself or your clothes which can ignite. Wash your skin and change clothes immediately.

1. Use only an approved gasoline container.
2. Never fill containers inside a vehicle or on a truck or trailer bed with a plastic liner. Always place containers on the ground away from your vehicle before filling.
3. When practical, remove gas-powered equipment from the truck or trailer and refuel it on the ground. If this is not possible, then refuel such equipment on a trailer with a portable container, rather than from a gasoline dispenser nozzle.
4. Keep the nozzle in contact with the rim of the fuel tank or container opening at all times until fueling is complete. Do not use a nozzle lock-open device.
5. Extinguish all cigarettes, cigars, pipes and other sources of ignition.
6. Never fuel machine indoors.
7. Never remove gas cap or add fuel while the engine is hot or running. Allow engine to cool at least two minutes before refueling.
8. Never over fill fuel tank. Fill tank to no more than ½ inch below bottom of filler neck to allow space for fuel expansion.
9. Replace gasoline cap and tighten securely.
10. If gasoline is spilled, wipe it off the engine and equipment. Move unit to another area. Wait 5 minutes before starting the engine.
11. To reduce fire hazards, keep machine free of grass, leaves, or other debris build-up. Clean up oil or fuel spillage and remove any fuel soaked debris.
12. Never store the machine or fuel container inside where there is an open flame, spark or pilot light as on a water heater, space heater, furnace, clothes dryer or other gas appliances.

## Operation

1. Do not put hands and feet near rotating parts or in the feeding chambers and discharge opening. Contact with the rotating impeller can amputate fingers, hands, and feet.
2. Before starting the machine, make sure the chipper chute, feed intake, and cutting chamber are empty and free of all debris.
3. Thoroughly inspect all material to be shredded and remove any metal, rocks, bottles, cans, or other foreign objects which could cause personal injury or damage to the machine.

4. If the impeller strikes a foreign object or if your machine should start making an unusual noise or vibration, immediately shut the engine off. Allow the impeller to come to a complete stop. Disconnect the spark plug wire, ground it against the engine and perform the following steps:
  - a. Inspect for damage.
  - b. Repair or replace any damaged parts.
  - c. Check for any loose parts and tighten to assure continued safe operation.
5. Do not allow an accumulation of processed material to build up in the discharge area. This can prevent proper discharge and result in kickback of material through the feed opening.
6. Do not attempt to shred or chip material larger than specified on the machine or in this manual. Personal injury or machine damage could result.
7. Never attempt to unclog either the feed intake or discharge opening while the engine is running. Shut the engine off, wait until all moving parts have stopped, disconnect the spark plug wire and ground it against the engine before clearing debris.
8. Never operate without vacuum bag and discharge chute properly attached to the machine. Never empty or change vacuum bag while the engine is running. Vacuum bag must be kept closed at all times during operation.
9. Never operate without either the inlet nozzle or optional hose attachment (if applicable) properly attached to the machine. Never attempt to attach or change either attachment while the engine is running.
10. Keep all guards, deflectors and safety devices in place and operating properly.
11. Keep your face and body back and to the side of the chipper chute while feeding material into the machine to avoid accidental kickback injuries.
12. Never operate this machine without good visibility or light. Always be sure of your footing and keep a firm hold on the handles.
13. Do not operate this machine on a paved, gravel or non-level surface.
14. Do not operate this machine while under the influence of alcohol or drugs.
15. Muffler and engine become hot and can cause a burn. Do not touch.
16. Never pick up or carry machine while the engine is running.
17. If situations occur which are not covered in this manual, use care and good judgement. Contact Customer Support for assistance and the name of the nearest service dealer.

## Maintenance & Storage

1. Never tamper with safety devices. Check their proper operation regularly.
2. Check bolts and screws for proper tightness at frequent intervals to keep the machine in safe working condition. Also, visually inspect machine for any damage and repair, if needed.
3. Before cleaning, repairing, or inspecting, stop the engine and make certain the impeller and all moving parts have stopped. Disconnect the spark plug wire and ground it against the engine to prevent unintended starting.
4. Do not change the engine governor settings or overspeed the engine. The governor controls the maximum safe operating speed of the engine.
5. Maintain or replace safety and instruction labels, as necessary.
6. Follow this manual for safe loading, unloading, transporting, and storage of this machine.
7. Never store the machine or fuel container inside where there is an open flame, spark or pilot light such as a water heater, furnace, clothes dryer, etc.
8. Allow machine to cool at least 5 minutes before storing.
9. Always refer to the operator's manual for proper instructions on off-season storage.
10. If the fuel tank has to be drained, do this outdoors.
11. Observe proper disposal laws and regulations for gas, oil, etc. to protect the environment.
12. According to the Consumer Products Safety Commission (CPSC) and the U.S. Environmental Protection Agency (EPA), this product has an *Average Useful Life* of seven (7) years, or 60 hours of operation. At the end of the *Average Useful Life* have the machine inspected annually by an authorized service dealer to ensure that all mechanical and safety systems are working properly and not worn excessively. Failure to do so can result in accidents, injuries or death.

## Do not modify engine

To avoid serious injury or death, do not modify engine in any way. Tampering with the governor setting can lead to a runaway engine and cause it to operate at unsafe speeds. Never tamper with factory setting of engine governor.

## Notice Regarding Emissions

Engines which are certified to comply with California and federal EPA emission regulations for SORE (Small Off Road Equipment) are certified to operate on regular unleaded gasoline, and may include the following emission control systems: Engine Modification (EM), Oxidizing Catalyst (OC), Secondary Air Injection (SAI) and Three Way Catalyst (TWC) if so equipped.

## Spark Arrestor









**WARNING:** This machine is equipped with an internal combustion engine and should not be used on or near any unimproved forest-covered, brushcovered or grass-covered land unless the engine's exhaust system is equipped with a spark arrester meeting applicable local or state laws (if any).

If a spark arrester is used, it should be maintained in effective working order by the operator. In the State of California the above is required by law (Section 4442 of the California Public Resources Code). Other states may have similar laws. Federal laws apply on federal lands.

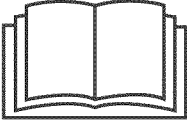
A spark arrester for the muffler is available through your nearest engine authorized service dealer or contact the service department, P.O. Box 361131 Cleveland, Ohio 44136-0019.

## Safety Symbols

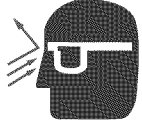
This page depicts and describes safety symbols that may appear on this product. Read, understand, and follow all instructions on the machine before attempting to assemble and operate.

Symbol	Description
	<b>READ THE OPERATOR'S MANUAL(S)</b> Read, understand, and follow all instructions in the manual(s) before attempting to assemble and operate
	<b>WARNING— ROTATING BLADES</b> Keep hands out of inlet and discharge openings while machine is running. There are rotating blades inside
	<b>BYSTANDERS</b> Keep bystanders, pets, and children at least 75 feet from the machine while it is in operation. Stop machine if anyone enters the area.
	<b>WARNING— THROWN OBJECTS</b> This machine may pick up and throw and objects which can ricochet.
	<b>EYE PROTECTION</b> Always wear safety glasses or safety goggles when operating this machine.
	<b>WARNING— GASOLINE IS FLAMMABLE</b> Allow the engine to cool at least two minutes before refueling.
	<b>WARNING— CARBON MONOXIDE</b> Never run an engine indoors or in a poorly ventilated area. Engine exhaust contains carbon monoxide, an odorless and deadly gas.



**WARNING:** Your Responsibility—Restrict the use of this power machine to persons who read, understand and follow the warnings and instructions in this manual and on the machine.

**SAVE THESE INSTRUCTIONS!**

## Contents of Carton

- One Chipper/Shredder Vacuum
- One Operator's Manual
- One Engine Operator's Manual
- One Upper and Lower Handle
- One Bag
- One Safety Glasses
- One Bottle of Oil

## Assembly

**NOTE:** This unit is shipped without gasoline or oil in the engine. Fill up gasoline and oil as instructed in the accompanying engine manual BEFORE operating your chipper shredder vacuum.

### Handle

1. Remove the hairpin clips from the handle brackets and the carriage screws and wing nuts from the lower handle.
  - a. Place the bottom holes in lower handle over the pins on the handle brackets with notch in handle pointing downwards and secure with hairpin clips. See Fig. 3-1.

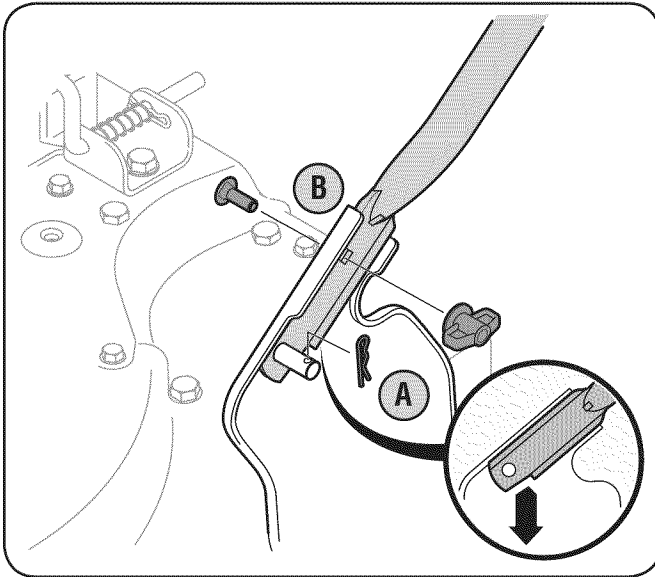

Figure 3-1

- b. Insert carriage screws through upper hole in lower handle from the inside and secure with wing nuts. See Fig. 3-1.

2. Unfold the upper handle until it aligns with lower handle. Make sure the rope guide is on the right side of upper handle. See Fig. 3-2A.

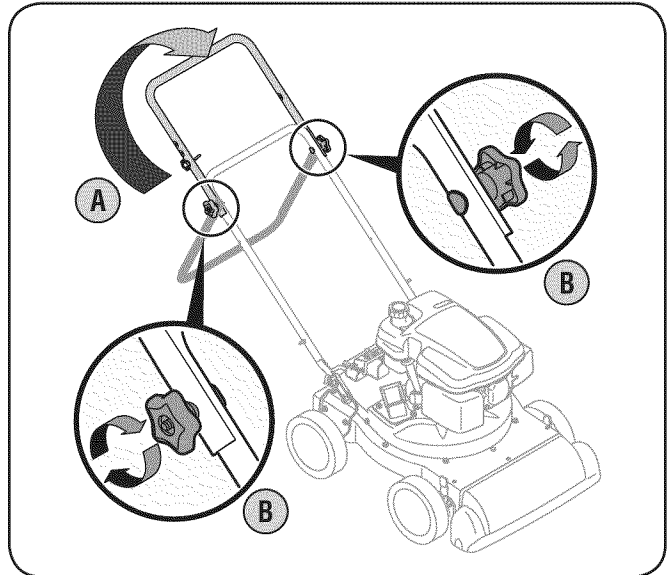

Figure 3-2

3. Secure the two handles by tightening the star knobs (carriage bolts must be seated properly into the handle). See Fig. 3-2B.

4. Loosen the wing nut that secures the rope guide to the right side of upper handle.
  - a. Slowly pull starter rope out of engine.
  - b. Slip the starter rope into the rope guide.
  - c. Tighten the wing nut. See Fig. 3-3.

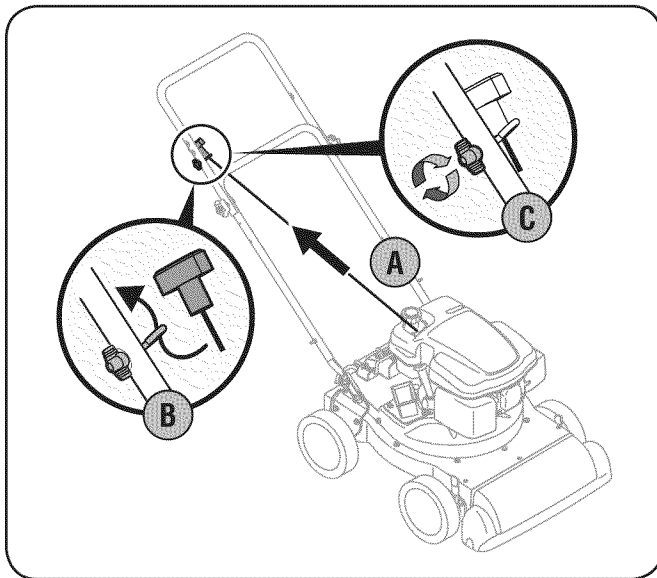

Figure 3-3

## Bag

1. Grasp bag handle with one hand and slide locking rod on mounting bracket with other hand toward engine. Use the end of mounting bracket as leverage when sliding the locking rod. See Fig. 3-4.

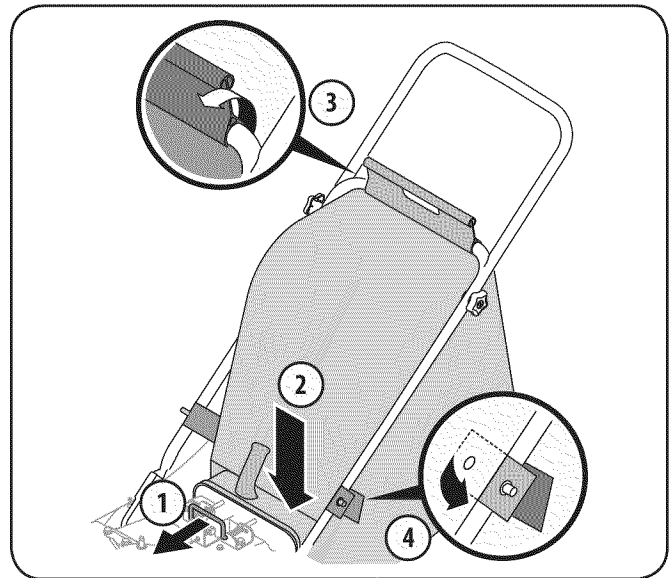

Figure 3-4

2. Slip bag over the rim of the discharge opening and release locking rod to secure bag in place.
3. Snap bag clip to the top of the lower handle.
4. Place the lower straps on the bag over the top of lower handle, hooking them on the studs. See Fig. 3-4.

**NOTE:** The bag/chute switch button attached to the mounting bracket must be fully depressed by the tip of front tab on bag handle when securing the bag or engine will not start.



## Adjustments

### Nozzle Height

The nozzle can be adjusted to any six positions, ranging from 5/8" to 4 1/8" ground clearance. The nozzle height has to be adjusted according to chipper shredder conditions.

1. Depress nozzle height adjustment lever towards wheel. See Fig. 3-5.

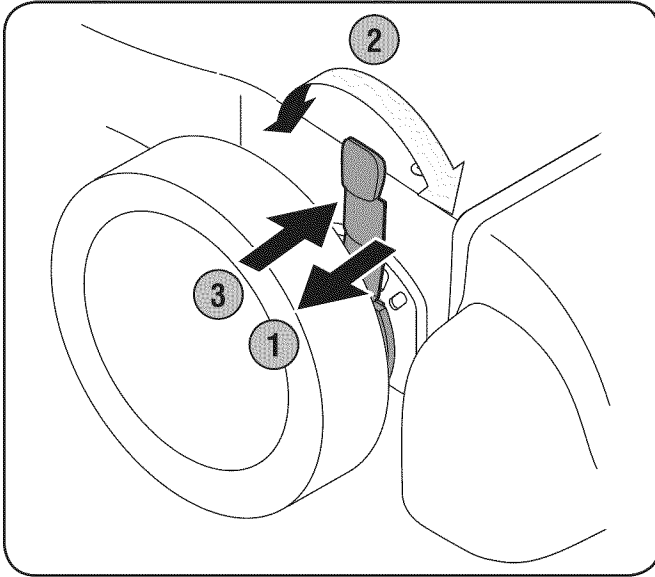

Figure 3-5

2. Move the height adjustment lever forward or backward to adjust the nozzle upwards or downwards. Make sure both levers are in the same position.
3. Release lever towards deck. See Fig. 3-5.

**NOTE:** In general, raise the nozzle height to vacuum a thick layer of leaves. Lower the nozzle height for smoother surfaces.

## Set-Up

### Gas and Oil Fill-Up

Refer to the separate engine owner's manual for additional engine information.

1. Add oil provided before starting unit for the first time out of the box.
2. Service the engine with gasoline as instructed in the Engine manual.



**WARNING:** Use extreme care when handling gasoline. Gasoline is extremely flammable and the vapors are explosive. Never fuel the machine indoors or while the engine is hot or running. Extinguish cigarettes, cigars, pipes and other sources of ignition.



**WARNING:** Never fill fuel tank indoors with engine running or until the engine has been allowed to cool for at least two minutes after running.

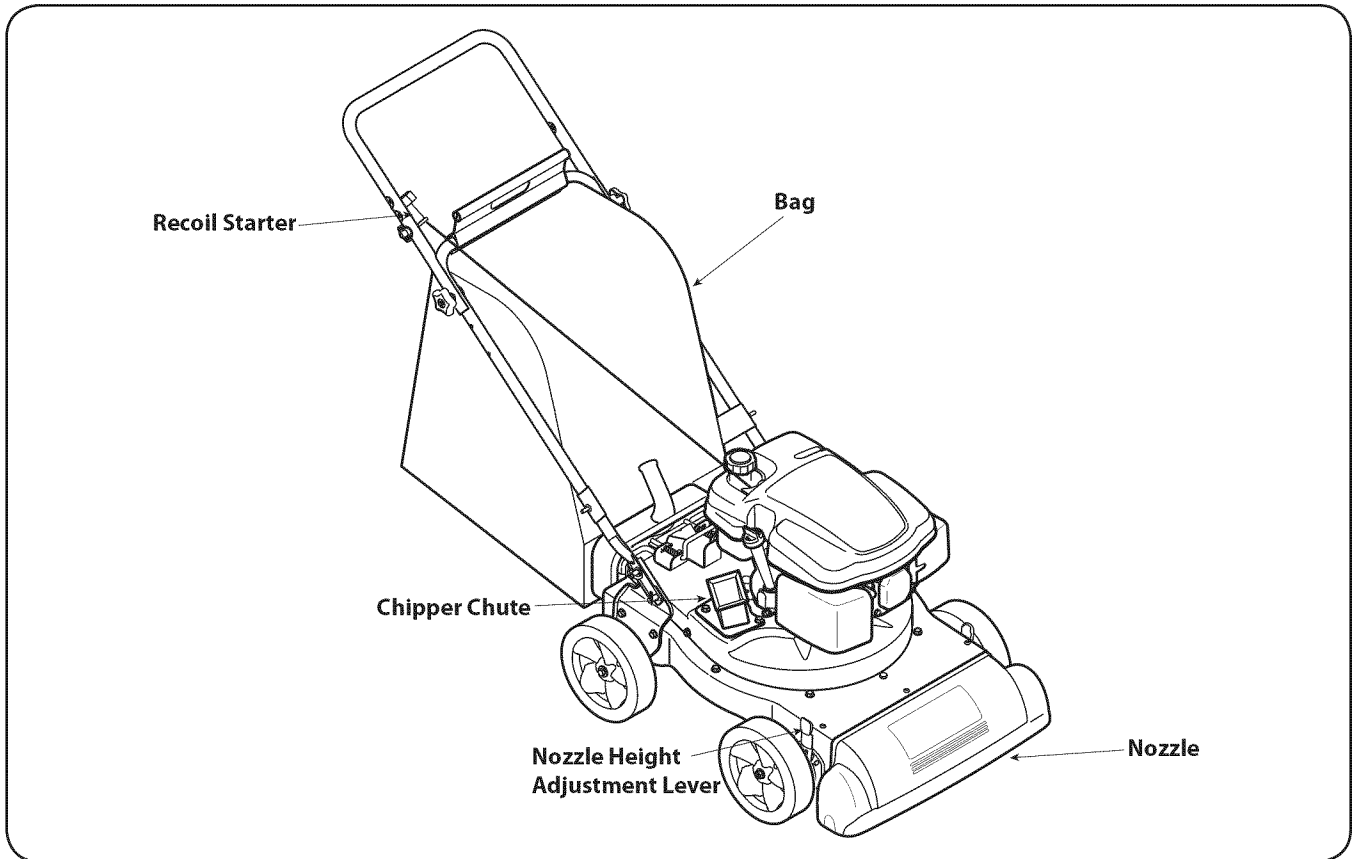

Figure 4-1



**WARNING:** The operation of any chipper shredder can result in foreign objects being thrown into the eyes, which can damage your eyes severely. Always wear the safety glasses provided with this unit or eye shields while operating or while performing any adjustments or repairs.

### Chipper Chute

Allows twigs and small branches up to 1-1/2" in diameter to be fed into the impeller for chipping. See Fig. 4-1.

### Nozzle Height Adjustment Lever

Used to adjust the nozzle ground clearance ranging approximately 5/8" to 4 1/8".

### Nozzle

Yard waste such as leaves or pine needles can be vacuumed up through the nozzle for shredding.

### Bag

Collects shredded material fed through the chipper chute or vacuumed through the nozzle.

### Recoil Starter

The recoil starter is attached to the right upper handle. Stand behind unit and pull the recoil starter to start engine.

### Engine Controls

See the separate engine manual for the location and function of the controls on the engine.

## Starting & Stopping Engine

Refer to the Engine Operator's manual packed with your chipper/shredder vacuum for instructions on starting and stopping the engine.

## To Empty Bag

1. Unhook bag straps from the lower handle.
2. Unsnap bag clip from the top of lower handle. See Fig. 5-1.

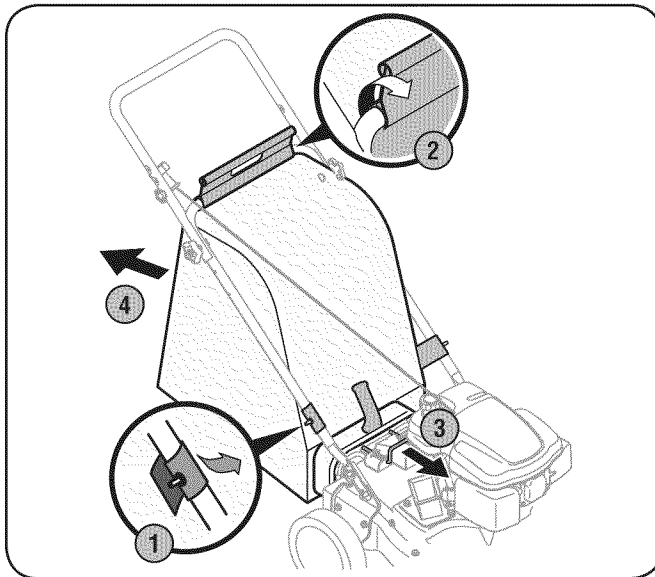

Figure 5-1

3. Grasp bag handle with one hand and pull lock rod on mounting bracket with other hand toward engine to release.
4. Lift bag off back of unit.

5. Twist the two buttons on the back of the bag to unlock and empty contents. See Fig. 5-2. Hold bag handle and bag clip while emptying the contents.

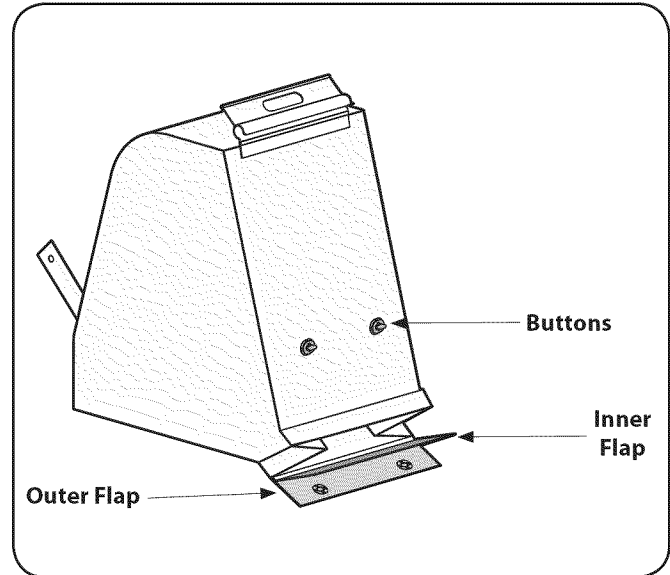

Figure 5-2

6. Compress bag opening and fold inner flap over opening.
7. Fold outer flap over inner flap and insert buttons on the bag through metal outlets. See Fig. 5-2.
8. Twist the buttons to lock bag. Place bag back onto unit as instructed in Assembly & Set-Up.



**WARNING:** Do not at any time make any adjustments without first stopping engine and disconnecting spark plug wire.



**WARNING:** Do not attempt to shred, chip, or vacuum any material larger than specified on the machine or in this manual. Personal injury or damage to the machine could result.

**IMPORTANT:** The flail screen is located inside the housing in the discharge area. If the flail screen becomes clogged, remove and clean as instructed in Maintenance & Adjustments. For best performance, it is also important to keep the chipper blade sharp.

## Maintenance

### General Recommendations

- Always observe safety rules when performing any maintenance.
- The warranty on this chipper/shredder vacuum does not cover items that have been subjected to operator abuse or negligence. To receive full value from warranty, operator must maintain the equipment as instructed here.
- Changing of engine-governed speed will void engine warranty.
- All adjustments should be checked at least once each season.
- Periodically check all fasteners and make sure these are tight.



**WARNING:** Always stop engine, disconnect spark plug, and ground against engine before performing any type of maintenance on your machine.

### Lubrication

1. Lubricate each wheel shoulder screw (rear wheel) and pivot arm axle (front wheel) once a season with light oil.
2. Lubricate the pivot points of the nozzle height adjustment levers once a season with light oil. See Fig. 6-1.

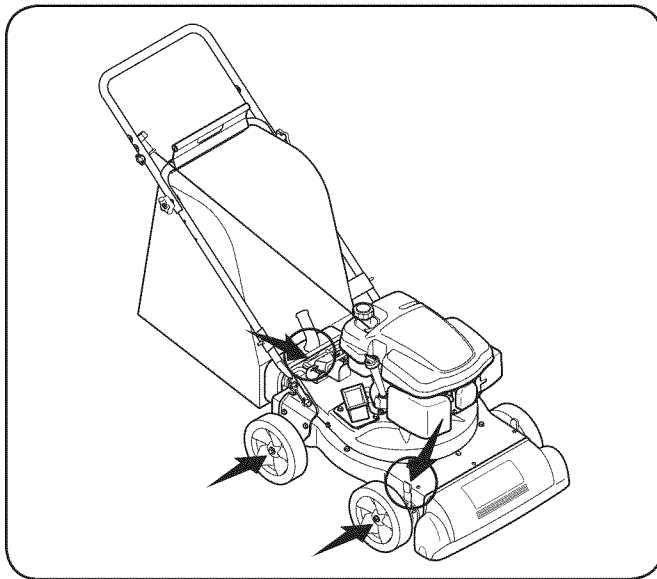

Figure 6-1

3. Lubricate the locking rod with light oil to ease the application of attaching on or removing bag.
4. Follow the separate engine manual packed with your unit for lubrication instructions.

### Equipment Care

- Clean the chipper/shredder vacuum thoroughly after each use.
- Wash bag periodically with water. Allow to dry thoroughly in shade.
- If the flail screen becomes clogged, remove and clean as instructed below.

**NOTE:** Cleaning with a forceful spray of water is not recommended as it could contaminate the fuel system.

### Engine Care

Refer to the Engine Operator's Manual packed with your chipper/shredder vacuum for all engine maintenance.



**WARNING:** Before performing any type of maintenance on the machine, wait for all parts to stop moving and disconnect the spark plug wire. Failure to follow this instruction could result in personal injury or property damage.

## Removing the Flail Screen

If the discharge area becomes clogged, remove the flail screen and clean area as follows:

1. Stop the engine. Make certain the chipper/shredder vacuum has come to a complete stop.
2. Before unclogging the discharge chute, disconnect and ground the spark plug wire to retaining post.
3. Remove the vacuum bag from the unit as instructed in the OPERATION section to obtain access to flail screen.
4. Remove self tapping screw on right side of unit that attaches to the flail screen. See Fig. 6-2.
5. Remove hex screw on top of rear housing near mounting bracket and the flange lock nut that secures flail screen. See Fig. 6-2.
6. Remove and clean the screen by scraping or washing with water. See Fig. 6-3.
7. Reinstall the screen.

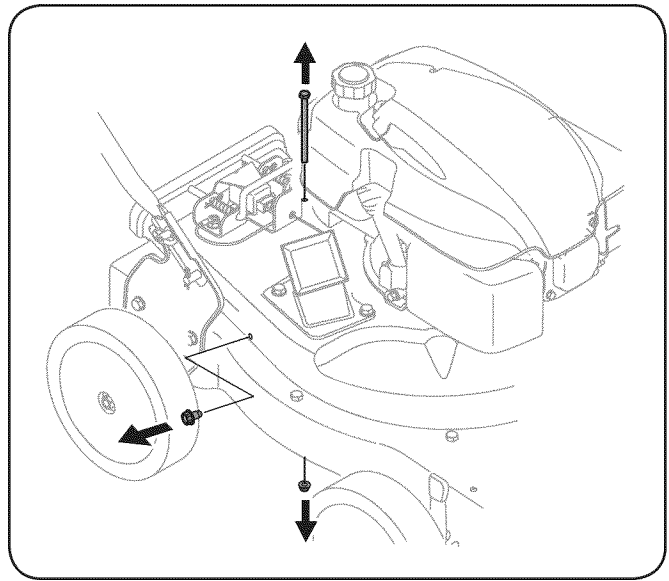

Figure 6-2

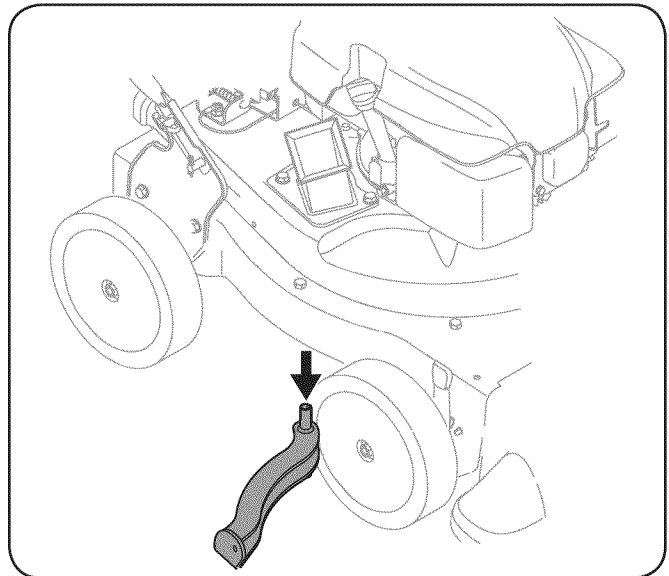

Figure 6-3

## Blade Care



**WARNING:** Before performing any type of maintenance on the machine, wait for all parts to stop moving and disconnect the spark plug wire. Failure to follow this instruction could result in personal injury or property damage.

**NOTE:** When tipping the unit, empty the oil and fuel tank and keep engine spark plug side up.

1. Disconnect and ground the spark plug wire to retaining post.
2. Remove bag assembly.
3. Remove the three hex cap screws holding the chipper chute to the upper housing. See Fig. 7-1.

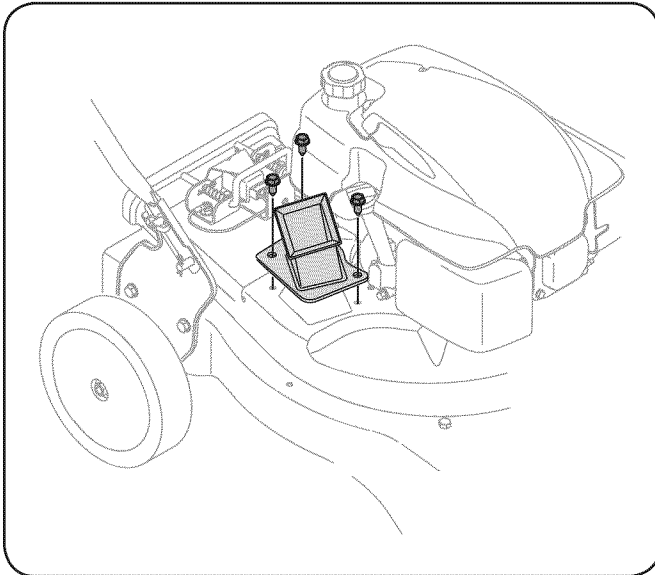

**Figure 7-1**

4. Remove the flange lock nuts, front wheels, and wave washers that attach to the pivot arm assemblies. See Fig. 7-2.

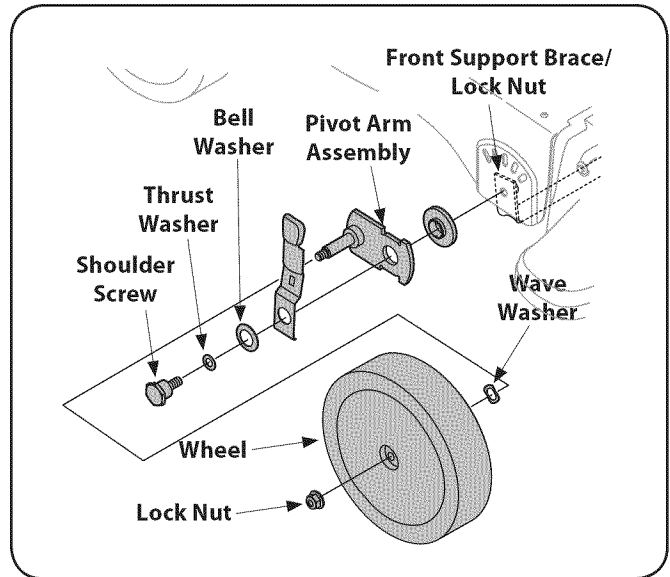

**Figure 7-2**

5. Remove the shoulder screws, thrust washers, and bell washers that go through the pivot arms to the front support brace. The front support brace and lock nut can be removed at this time as well.
6. Remove the three screws on the upper housing that secure the nozzle cover. See Fig. 7-3.

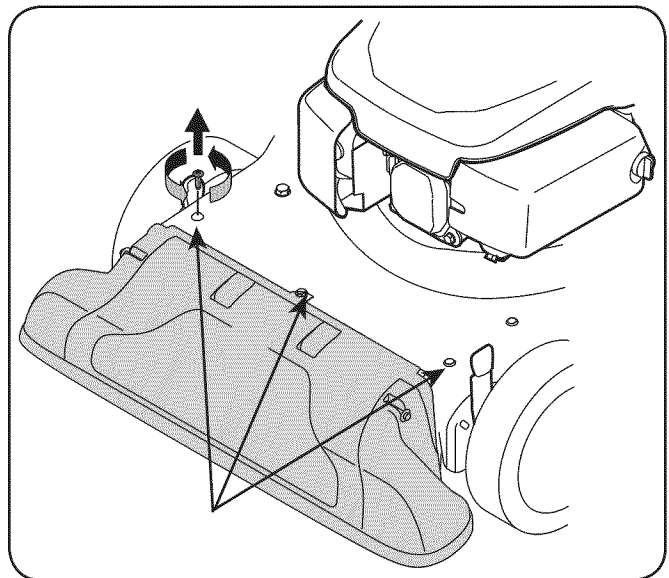

**Figure 7-3**

- Carefully tilt and support the unit up to provide access underneath to the nozzle mounting hardware and impeller. Remove the three shoulder bolts securing the black plastic lower flail housing to the lower housing. Refer to Fig. 7-4.

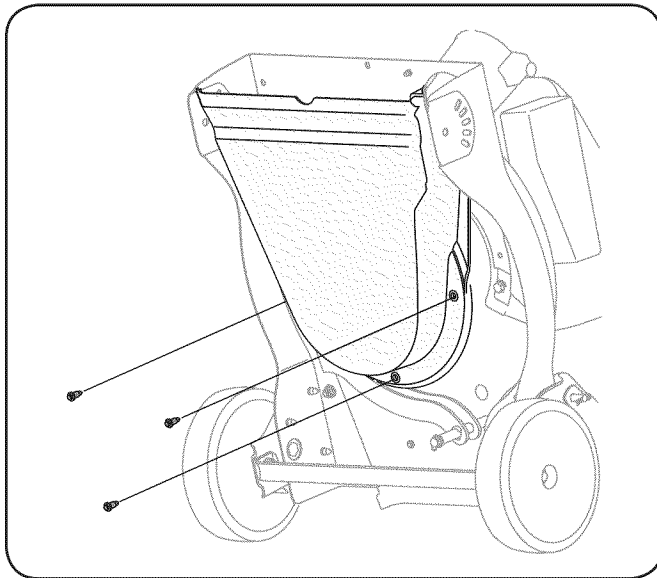

Figure 7-4

- Tilt top of black plastic lower flail housing toward the engine to remove.
- Using a 3/16" allen wrench, remove the flat head cap screws that hold the chipper blade to the impeller. These screws are accessible through the opening created when the chipper chute was removed earlier. See Fig. 7-5.

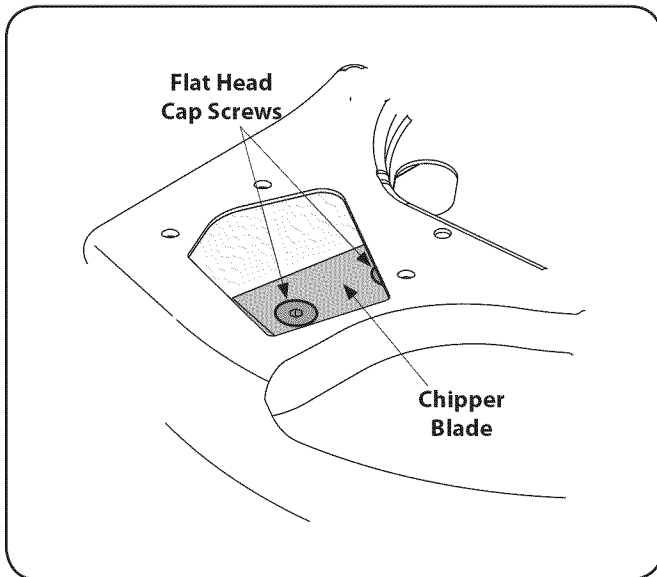

Figure 7-5

- The nuts on the flat head cap screws can be reached from underneath using a 1/2-inch socket, universal, and extension. See Fig. 7-6.

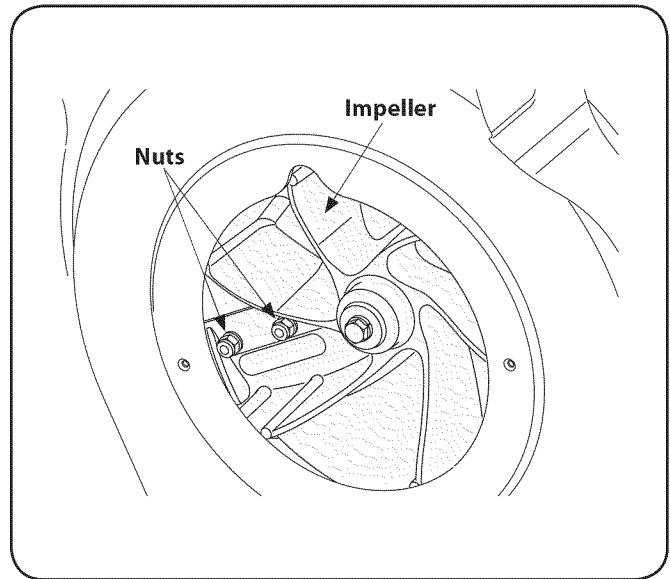

Figure 7-6

- Replace or sharpen chipper blade. The blade can be sharpened with a file or on a grinding wheel.



**WARNING:** The chipper blade is sharp. When sharpening blade, wear leather work gloves to protect your hands and follow the original angle of grind.

- Reassemble by performing the previous steps in the opposite order and manner of removal.

**NOTE:** Tighten blade screws to 210 - 250 in-lbs. Make certain chipper blade is reassembled with the sharp edge facing upward.

### Off-Season Storage

- When storing the chipper/shredder vacuum in an unventilated or metal storage shed, care should be taken to rustproof the non-painted surfaces. Using a light oil or silicone, coat the equipment, especially any springs, bearings, and cables.
- Remove all dirt from exterior of engine and equipment.
- Follow lubrication recommendations.
- Refer to engine manual for correct engine storage instructions.
- Store equipment in a clean, dry area. Do not store in an area where equipment is present that may use a pilot light or has a component that can create a spark.

Problem	Cause	Remedy
Engine Fails to start	<ol style="list-style-type: none"> <li>1. Throttle lever (if equipped) not in correct starting position.</li> <li>2. Engine switch (if equipped) in OFF position.</li> <li>3. Spark plug wire disconnected.</li> <li>4. Choke not in CHOKE position (if equipped).</li> <li>5. Fuel tank empty or stale fuel.</li> <li>6. Fuel shut-off valve closed (if equipped).</li> <li>7. Faulty spark plug.</li> <li>8. Bag/chute switch button is not fully depressed.</li> </ol>	<ol style="list-style-type: none"> <li>1. Move throttle lever to FAST or START position.</li> <li>2. Move engine switch to ON position.</li> <li>3. Connect wire to spark plug.</li> <li>4. Move choke lever to CHOKE position.</li> <li>5. Fill tank with clean, fresh gasoline.</li> <li>6. Turn on fuel shut-off valve.</li> <li>7. Clean, adjust gap, or replace.</li> <li>8. Make certain the bag is correctly secured, and the bag/chute switch button is fully depressed.</li> </ol>
Engine runs erratic	<ol style="list-style-type: none"> <li>1. Spark plug boot loose.</li> <li>2. Unit running on CHOKE (if equipped).</li> <li>3. Blocked fuel line or stale fuel.</li> <li>4. Low engine RPM.</li> <li>5. Water or dirt in fuel system.</li> <li>6. Dirty air cleaner.</li> <li>7. Carburetor out of adjustment.</li> </ol>	<ol style="list-style-type: none"> <li>1. Connect and tighten spark plug boot.</li> <li>2. Move choke lever to OFF position.</li> <li>3. Clean fuel line; fill tank with clean, fresh gasoline.</li> <li>4. Always run engine at full throttle (if equipped).</li> <li>5. Drain fuel tank. Refill with fresh fuel.</li> <li>6. Refer to engine manual.</li> <li>7. See authorized service dealer.</li> </ol>
Engine overheats	<ol style="list-style-type: none"> <li>1. Engine oil level low.</li> <li>2. Dirty air cleaner.</li> </ol>	<ol style="list-style-type: none"> <li>1. Fill crankcase with proper oil.</li> <li>2. Refer to engine manual.</li> </ol>
Occasional skips (hesitates) at high speed	<ol style="list-style-type: none"> <li>1. Spark plug gap too close.</li> <li>2. Carburetor idle mixture adjustment improperly set.</li> </ol>	<ol style="list-style-type: none"> <li>1. Remove spark plug and adjust gap to .030".</li> <li>2. See authorized service dealer.</li> </ol>
Excessive Vibration	<ol style="list-style-type: none"> <li>1. Loose parts or damaged impeller.</li> </ol>	<ol style="list-style-type: none"> <li>2. See authorized service dealer.</li> </ol>
Unit does not discharge	<ol style="list-style-type: none"> <li>1. Discharge area clogged.</li> <li>2. Foreign object lodged in impeller.</li> <li>3. Low engine RPM.</li> <li>4. Vacuum bag is full.</li> </ol>	<ol style="list-style-type: none"> <li>1. Stop engine immediately and disconnect spark plug wire. Clean flail screen and inside of discharge opening.</li> <li>2. Stop engine and disconnect spark plug wire. Remove lodged object.</li> <li>3. Always run engine at full throttle.</li> <li>4. Empty bag.</li> </ol>
Rate of discharge slows considerably or composition of discharged material changes	<ol style="list-style-type: none"> <li>1. Low engine RPM.</li> <li>2. Chipper blade dull.</li> </ol>	<ol style="list-style-type: none"> <li>1. Always run engine at full throttle.</li> <li>2. Replace chipper blade or see your authorized service dealer.</li> </ol>

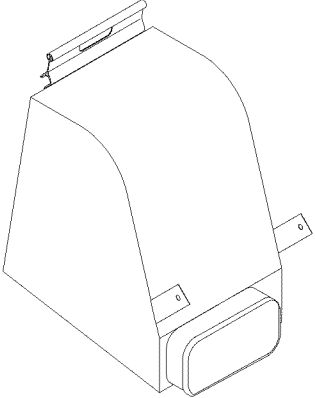
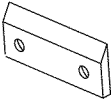
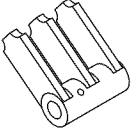
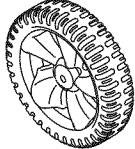

Component	Part Number and Description
	<p>664-04040      Bag</p>
	<p>981-0490      Chipper Blade</p>
	<p>719-0329      Flail Blade (2 total)</p>
	<p>734-1987      Wheel</p>





# MANUFACTURER'S LIMITED WARRANTY FOR



The limited warranty set forth below is given by MTD LLC with respect to new merchandise purchased and used in the United States and/or its territories and possessions, and by MTD Products Limited with respect to new merchandise purchased and used in Canada and/or its territories and possessions (either entity respectively, "MTD").

"MTD" warrants this product (excluding its *Normal Wear Parts and Attachments* as described below) against defects in material and workmanship for a period of two (2) years commencing on the date of original purchase and will, at its option, repair or replace, free of charge, any part found to be defective in materials or workmanship. This limited warranty shall only apply if this product has been operated and maintained in accordance with the Operator's Manual furnished with the product, and has not been subject to misuse, abuse, commercial use, neglect, accident, improper maintenance, alteration, vandalism, theft, fire, water, or damage because of other peril or natural disaster. Damage resulting from the installation or use of any part, accessory or attachment not approved by MTD for use with the product(s) covered by this manual will void your warranty as to any resulting damage.

*Normal Wear Parts* are warranted to be free from defects in material and workmanship for a period of thirty (30) days from the date of purchase. Normal wear parts include, but are not limited to items such as: batteries, belts, blades, blade adapters, tines, grass bags, wheels, rider deck wheels, seats, snow thrower skid shoes, friction wheels, shave plates, auger spiral rubber, engine oil, air filters, spark plugs and tires.

*Attachments* — MTD warrants attachments for this product against defects in material and workmanship for a period of one (1) year, commencing on the date of the attachment's original purchase or lease. Attachments include, but are not limited to items such as: grass collectors and mulch kits.

**HOW TO OBTAIN PARTS AND SERVICE:** Warranty service is available, WITH PROOF OF PURCHASE, through your local authorized service dealer. To locate the dealer in your area:

## In the U.S.A.

Check your Yellow Pages, or contact MTD LLC at P.O. Box 361131, Cleveland, Ohio 44136-0019, or call 1-800-800-7310, 1-330-220-4683 or log on to our Web site at [www.mtdproducts.com](http://www.mtdproducts.com).

## In Canada

Contact MTD Products Limited, Kitchener, ON N2G 4J1, or call 1-800-668-1238 or log on to our Web site at [www.mtdcanada.com](http://www.mtdcanada.com).

This limited warranty does **not** provide coverage in the following cases:

- a. Log splitter pumps, valves, and cylinders have a separate one-year warranty.
- b. Routine maintenance items such as lubricants, filters, blade sharpening, tune-ups, brake adjustments, clutch adjustments, deck adjustments, and normal deterioration of the exterior finish due to use or exposure.

- c. Service completed by someone other than an authorized service dealer.
- d. MTD does not extend any warranty for products sold or exported outside of the United States and/or Canada, and their respective possessions and territories, except those sold through MTD's authorized channels of export distribution.
- e. Replacement parts that are not genuine MTD parts.
- f. Transportation charges and service calls.
- g. MTD does not warrant this product for commercial use.

**No implied warranty, including any implied warranty of merchantability or fitness for a particular purpose, applies after the applicable period of express written warranty above as to the parts as identified. No other express warranty, whether written or oral, except as mentioned above, given by any person or entity, including a dealer or retailer, with respect to any product, shall bind MTD. During the period of the warranty, the exclusive remedy is repair or replacement of the product as set forth above.**

**The provisions as set forth in this warranty provide the sole and exclusive remedy arising from the sale. MTD shall not be liable for incidental or consequential loss or damage including, without limitation, expenses incurred for substitute or replacement lawn care services or for rental expenses to temporarily replace a warranted product.**

Some states do not allow the exclusion or limitation of incidental or consequential damages, or limitations on how long an implied warranty lasts, so the above exclusions or limitations may not apply to you.

In no event shall recovery of any kind be greater than the amount of the purchase price of the product sold. **Alteration of safety features of the product shall void this warranty.** You assume the risk and liability for loss, damage, or injury to you and your property and/or to others and their property arising out of the misuse or inability to use the product.

This limited warranty shall not extend to anyone other than the original purchaser or to the person for whom it was purchased as a gift.

**HOW STATE LAW RELATES TO THIS WARRANTY:** This limited warranty gives you specific legal rights, and you may also have other rights which vary from state to state.

**IMPORTANT:** Owner must present Original Proof of Purchase to obtain warranty coverage.

**MTD LLC, P.O. BOX 361131 CLEVELAND, OHIO 44136-0019; Phone: 1-800-800-7310, 1-330-220-4683  
MTD Canada Limited - KITCHENER, ON N2G 4J1; Phone 1-800-668-1238**