

**SEARS**

**owners  
manual**

**MODEL NO.**

390.262401

390.262501

390.262601

**CAUTION:**  
Read All Instructions  
Carefully Before Start-  
ing The Installation.

Save This Manual For  
Future Reference.

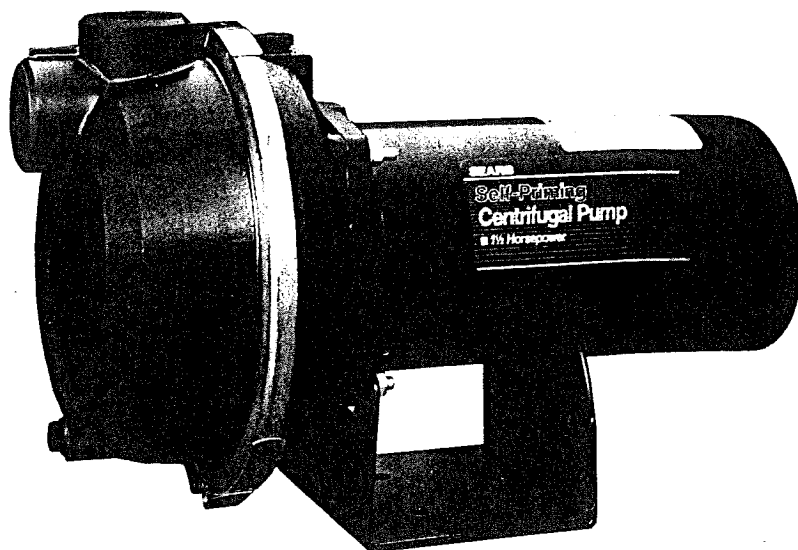

**"HYDRO-GLASS"®  
SELF-PRIMING  
CENTRIFUGAL PUMP**

- Installation
- Operation
- Repair Parts

Sears, Roebuck and Co., Chicago, Ill. 60684 U.S.A.

Carefully read all safety instructions in this manual or on the pump.

**▲** This is the **Warning** symbol. When you see this symbol on any part of this manual, look for one of the following symbols and be alert to the potential for personal injury.

**▲ DANGER** Warns about hazards that will cause serious injury, death or major property damage if ignored.

**▲ WARNING** Warns about hazards that can cause personal injury, death or major property damage if ignored.

**▲ CAUTION** Warns about hazards that will or can cause personal injury or property damage if ignored.

The word **NOTICE** is used for special instructions which are important to avoid hazards.

## CONTENTS

Safety/Introduction .....	2
Warranty .....	3
Installation .....	4-6
Operation .....	7
Maintenance .....	10
Troubleshooting/Pump Performance .....	11
Repair Parts .....	12-13

## INTRODUCTION

Please take a few minutes to read our instructions before you install and use your pump. This will help you obtain the full benefits from this pump. It will also help you avoid any needless service costs that result from causes we cannot control and cannot cover in our warranty.

### Electrical Safety

 <p><b>▲ WARNING</b></p> <p><b>Hazardous voltage. Can shock, burn, or cause death.</b></p> <p>Ground pump before connecting to power supply.</p>	<p><b>▲</b> Wire motor for correct voltage. See "Electrical" section of this manual and motor nameplate.</p>
	<p><b>▲</b> Ground motor before connecting to power supply.</p>
	<p><b>▲</b> Meet National Electrical Code and local codes for all wiring.</p>
	<p><b>▲</b> Follow wiring instructions in this manual when connecting motor to power lines.</p>

Make workshop childproof, use padlocks and master switches; remove starter keys.

### General Safety

	<p><b>▲ WARNING</b></p> <p><b>Hazardous pressure! Do not run pump against closed discharge.</b></p> <p>Release all pressure on system before working on any component.</p>
--	--

Pump is designed as a lawn sprinkler only. To avoid heat build-up, over pressure hazard and possible injury, do not use in a pressure tank (domestic water) system. Do not use as a booster pump; pressurized suction may cause pump body to explode.

Do not allow pump or piping system to freeze. Freezing can damage pump and pipe, may lead to injury from equipment failure, and will void warranty.

Pump water only with this pump.

Periodically inspect pump and system components.

Wear safety glasses when working on pumps.

Keep work area clean, uncluttered and well lighted; store properly all unused tools and equipment.

Keep visitors at a safe distance from the work areas.

## Before You Install Your Pump

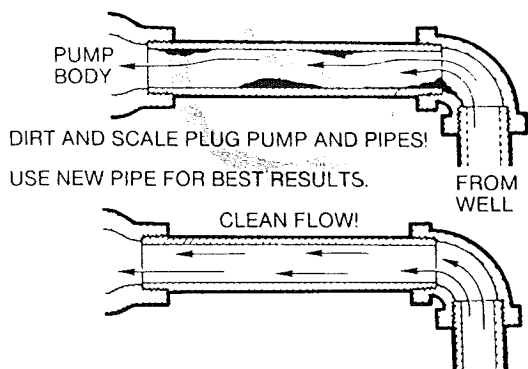

Figure 1—No Dirt or Scale in Suction Pipe

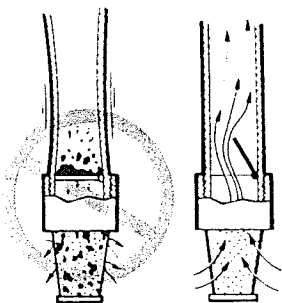

Figure 2—Foot Valve Must Work Freely

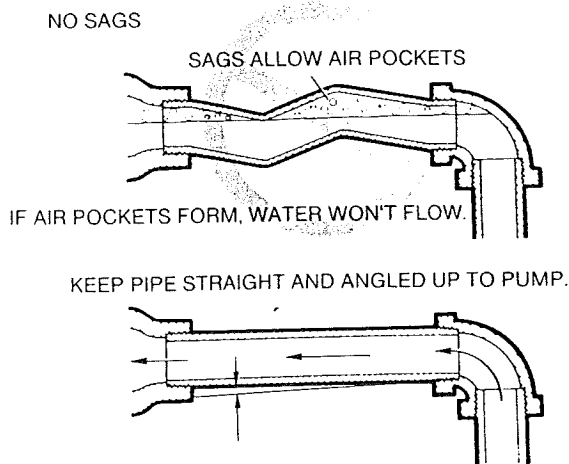

Figure 3—No Air Pockets in Suction Pipe

PIPE JOINT COMPOUND WILL DAMAGE PLASTIC.

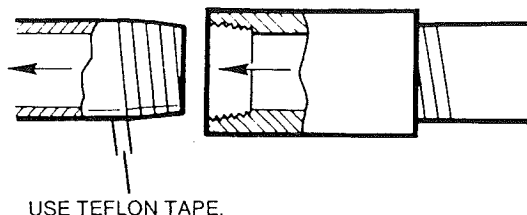
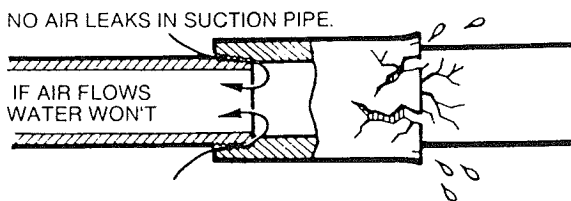

Figure 4—Suction Pipe Must Not Leak

**NOTICE:** Well must not be more than 20' depth to water.

1. Long runs and many fittings increase friction and reduce flow. Locate pump as close to well as possible: use as few elbows and fittings as possible.
2. Be sure well is clear of sand. Sand will plug the pump and void the warranty.
3. Protect pump and all piping from freezing. Freezing will split pipe, damage pump and void the warranty. Check locally for frost protection requirements (usually pipe must be 12" below frost line and pump must be insulated).
4. Be sure all pipes and foot valve are clean and in good shape.
5. No air pockets in suction pipe.
6. No leaks in suction pipe. Use Teflon tape or Plasto-Joint Stik to seal pipe joints.
7. Unions installed near pump and well will aid in servicing. Leave room to use wrenches.
8. **⚠WARNING** Pump body may explode if used as a booster pump. DO NOT use in a booster application.

### FULL ONE YEAR WARRANTY ON PUMPS

For one year from the date of purchase, Sears will repair or replace this pump, free of charge, if defective in material or workmanship.

### LIMITED WARRANTY ON SEARS HYDRO-GLASS® PUMPS

After one year and through two years from the date of purchase, Sears will furnish, free of charge, a replacement part for any defective part. You pay for labor.

This warranty does not cover repairs or replacement parts necessary because of abuse or negligence including failure to install, adjust and operate this pump according to the instructions in the owners manual.

### LIMITATION OF LIABILITY

SEARS WILL NOT BE LIABLE FOR LOSS OR DAMAGE TO PROPERTY OR ANY INCIDENTAL OR CONSEQUENTIAL LOSS OR EXPENSE FROM PROPERTY DAMAGE DUE DIRECTLY OR INDIRECTLY FROM THE USE OF THIS PRODUCT.

Some states do not allow the exclusion or limitation of incidental or consequential damages, so the above limitation or exclusion may not apply to you.

WARRANTY SERVICE IS AVAILABLE BY SIMPLY CONTACTING THE NEAREST SEARS SERVICE CENTER/DEPARTMENT IN THE UNITED STATES. This warranty applies only while the product is in use in the United States.

This warranty gives you specific legal rights, and you may also have other rights which vary from state to state.

Sears, Roebuck and Co., Dept. 731CR-W, Sears Tower, Chicago, IL 60684

# Well Pipe Installation

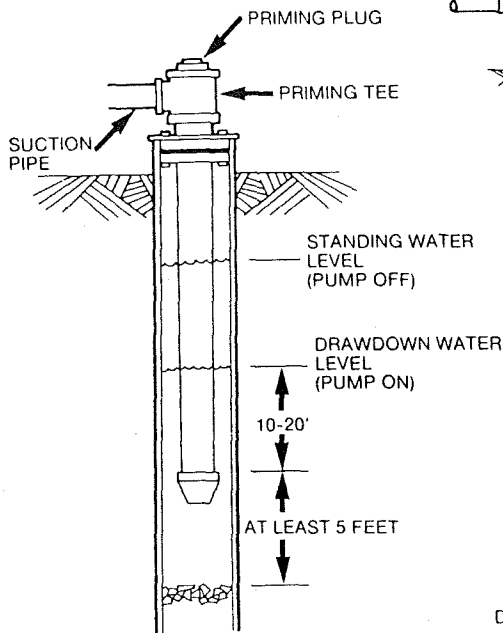

Figure 6—Cased/Dug Well Installation

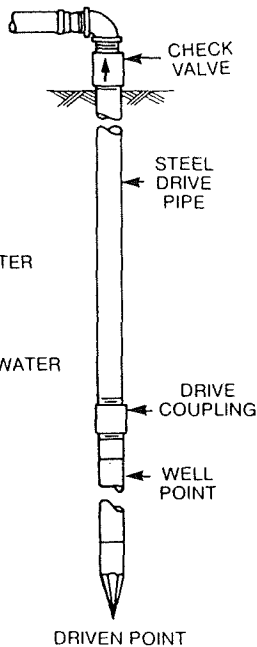

Figure 7—Driven Point Installation

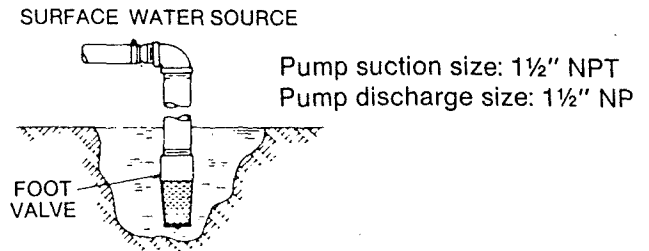

Figure 5—Match Pump to Water Source

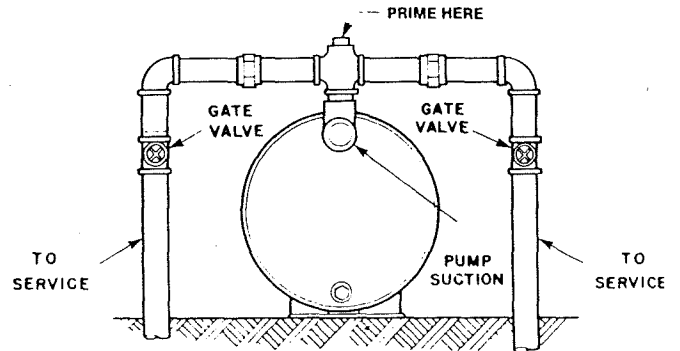

Figure 8—Multiple Discharge

**NOTICE:** Use the installation method below which matches your well type.

## CASED WELL INSTALLATION

1. Inspect foot valve to be sure it works freely. Inspect strainer to be sure it is clean.
2. Connect foot valve and strainer to the first length of suction pipe and lower pipe into well. Add sections of pipe as needed, using Teflon tape on male threads. Be sure that all suction pipe is leakproof or pump will lose prime and fail to pump. Install foot valve 10 to 20 feet below the lowest level to which water will drop while pump is operating (pumping water level). Your well driller can furnish this information.
3. To prevent sand and sediment from entering the pumping system, the foot valve/strainer should be at least 5 feet above the bottom of the well.
4. When the proper depth is reached, install a sanitary well seal over the pipe and in the well casing. Tighten the bolts to seal the casing.
5. When using a foot valve, a priming tee and plug as shown in Figure 6 are recommended.

## DUG WELL INSTALLATION

Same as cased well installation.

## DRIVEN POINT INSTALLATION

1. Connect the suction pipe to the drive point as illustrated in Figure 7. Keep horizontal pipe run as short as possible. Use Teflon tape on male pipe threads. Multiple well points may be necessary to provide sufficient water to pump.

2. Install a check valve in horizontal pipe. Flow arrow on check valve must point toward pump.

## HORIZONTAL PIPING FROM WELL TO PUMP

1. Never install a suction pipe that is smaller than the suction port of the pump.
2. To aid priming on well point installations, install a line check valve as shown in Figure 7. Be sure check valve flow arrow points toward pump.

## DISCHARGE PIPE SIZES

1. If increasing discharge pipe size, install reducer in pump discharge port. Do not increase pipe size by stages.
2. When the pump is set away from the points of water use, the discharge pipe size should be increased to reduce pressure losses caused by friction.
  - Up to 100' run: Same size as pump discharge port.
  - 100' to 300' run: Increase one pipe size.
  - 300' to 600' run: Increase two pipe sizes.

## LAWN SPRINKLING APPLICATION

This pump is designed for lawn sprinkling. It is designed to deliver plenty of water at full sprinkler pressure. It can pump from a pond, cistern or well points.

Pump discharge can be divided to supply two (2) or more sprinkler systems. A suggested multiple discharge to service is shown in Figure 8.

Do not use in a pressure tank or booster pump application.

## Pump/Piping Installation

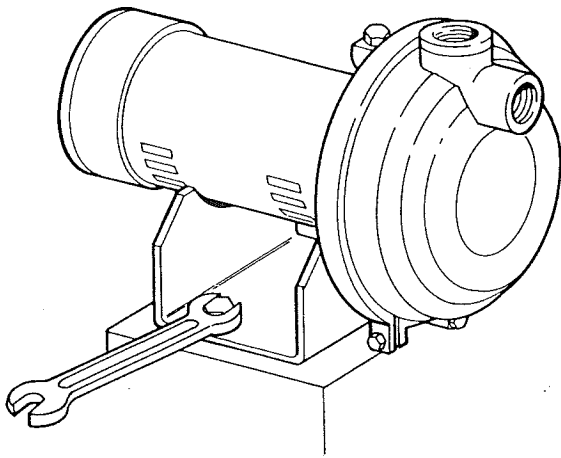

Figure 9—Bolt Pump Down

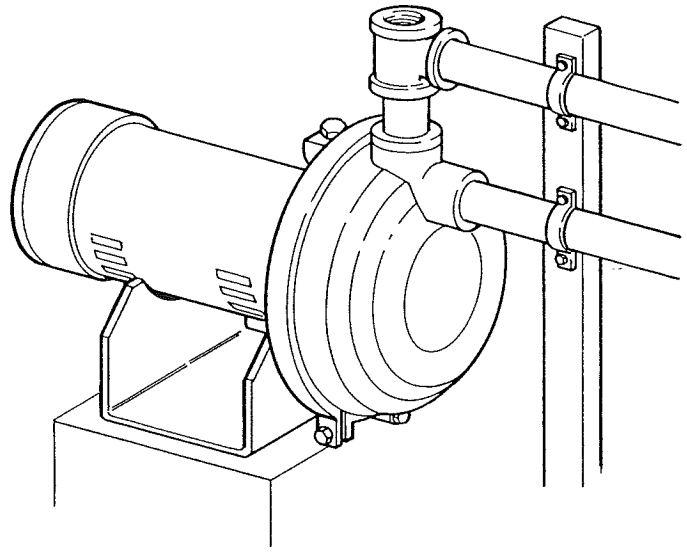

Figure 10—Independently Support All Piping Attached to Pump

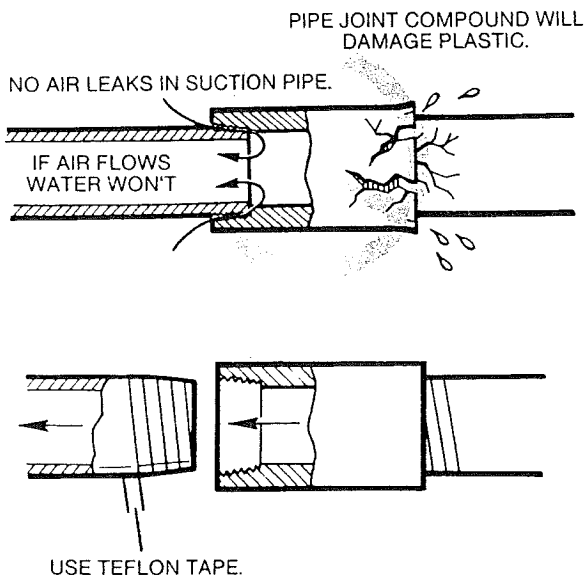

Figure 11—Use Teflon tape or Plasto-Joint Stik on pipe joints and connections to pump.

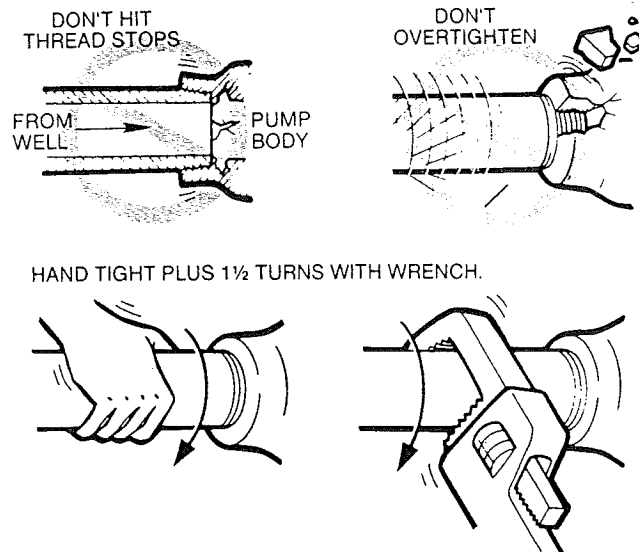

Figure 12—Don't overtighten!

### PUMP INSTALLATION

**NOTICE:** Use Teflon tape supplied with the pump for making all threaded connections to the pump itself. **Do not use pipe joint compounds on the pump;** they can react with the plastic in the pump components.

1. Bolt pump to solid, level foundation.
2. Support all piping connected to the pump.
3. Wrap 1½ to two layers of Teflon tape clockwise (as you face end of pipe) on all male threads being attached to pump.
4. Tighten joints hand tight plus 1½ turns. **Do not overtighten.**

**NOTICE:** Install pump as close to well head as possible. Long piping runs and many fittings create friction and reduce flow.

**NOTICE:** For long horizontal pipe runs, install a priming tee between check valve and well head as shown in Figure 6. For driven point installations, install a check valve as shown in Figure 7. Be sure check valve flow arrow points **toward** pump.

Use schedule 80 or iron pipe. See "Well Pipe Installation" for more information.

## Electrical Motor Terminal Block Wiring

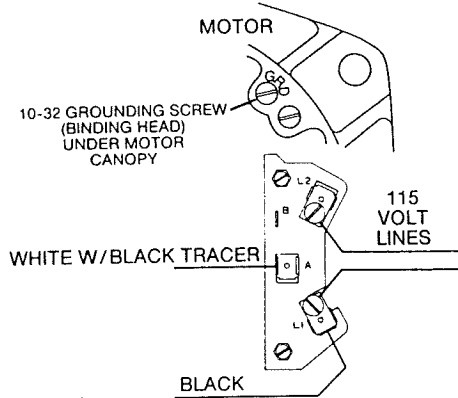

Figure 13 — 115V Wiring diagram

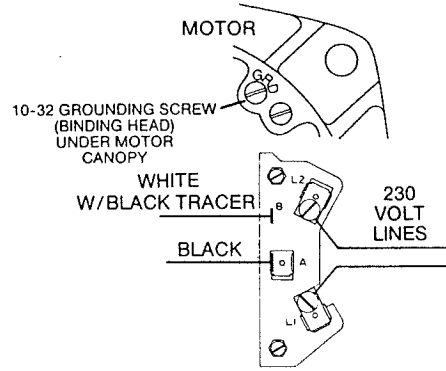



Figure 14 — 230V Wiring diagram

### WIRING CHART Recommended Wire and Fuse Sizes

Pump Model	HP	Volt	Max. Load Amps	Branch Fuse* Rating* Amps	Min. Wire Size	DISTANCE IN FEET FROM MOTOR TO METER					
						0' TO 50'	51' TO 100'	101' TO 200'	201' TO 300'	301' TO 400'	401' TO 500'
						WIRE SIZE					
390.262401	1	115 230	15.4 7.7	20 15	12 14	12 14	8 14	6 12	6 12	4 10	
390.262501	1½	115 230	18.2 9.1	30 15	10 14	10 14	8 14	6 12	4 10	2 10	
390.262601	2	230	12.0	15	14	14	12	12	10	8	

(\*) Dual element or Fusetron time delay fuses recommended for all motor circuits.

**⚠ WARNING**



**Hazardous voltage. Can shock, burn, or cause death.**

Ground pump before connecting to power supply.

- ⚠ Ground motor before connecting to electrical power supply.
- ⚠ Failure to ground motor can cause severe or fatal electrical shock hazard.
- ⚠ Do not ground to a gas supply line.
- ⚠ To avoid dangerous or fatal electrical shock, turn OFF power to motor before working on electrical connections.
- ⚠ Supply voltage must be within ±10% of nameplate

voltage. Incorrect voltage can cause fire or seriously damage motor and voids warranty. If in doubt consult a licensed electrician.

- ⚠ Use wire size specified in Wiring Chart (above.) if possible, connect pump to a separate branch circuit with no other appliances on it.

### WIRING

1. Install, ground, wire and maintain this pump in accordance with your local electrical code and all other codes and ordinances that apply. Consult your local building inspector for local code information.
2. Ground the pump permanently using a wire of size and type specified by local or National Electrical Code.
- ⚠ **Do not ground to a gas supply line.**
3. Connect ground wire first. Connect to ground first, then to green grounding terminal provided under motor canopy (see Figures 13 and 14) identified as GRD. Make ground connection to this terminal. **Do not** connect motor to electrical power supply until unit is permanently grounded; otherwise serious or fatal electrical shock hazard may be caused.
4. For best ground connection, connect to a grounded lead in the service panel or to a metal underground water pipe or well casing at least 10 feet long. If plastic pipe or insulated fittings are used, run ground wire directly to the metal well casing or use ground electrode furnished by the power company.

## Operation

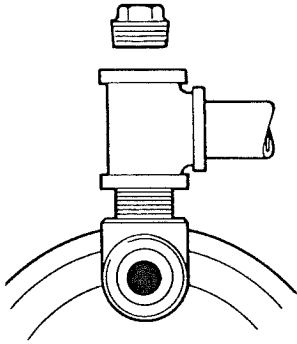

Figure 15—Remove Priming Plug

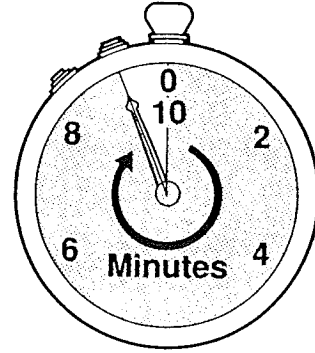

Figure 17—Run Ten Minutes or Less

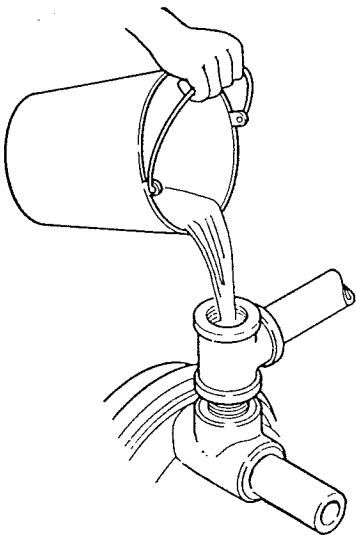

Figure 16—Fill Pump Before Starting

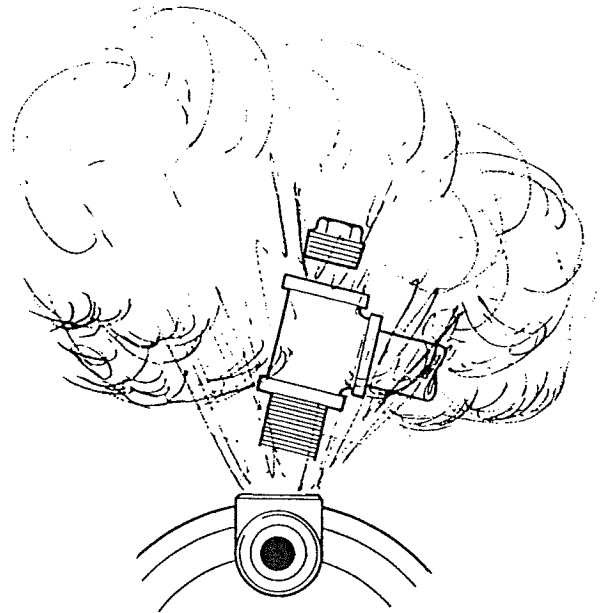

Figure 18—Do Not Run Pump with Discharge Shut-off.

### PRIMING THE PUMP

**NOTICE:** 'Priming' refers to the pump expelling all air in the system and beginning to move water from its source out into the system. It does not refer *only* to pouring water into the pump (although pouring water in is usually the first step).

**NOTICE: NEVER run pump dry.** Running pump without water in it will damage seals and can melt impeller and diffuser. To prevent damage, fill pump with water before starting.

1. Remove priming plug (Figure 15).
2. Make sure suction and discharge valves and any hoses on discharge side of pump are open.
3. Fill pump and suction pipe with water.
4. Replace priming plug, using Teflon tape on thread; tighten plug.  
**NOTICE:** If a priming tee and plug have been provided for a long horizontal run, be sure to fill suction pipe through this tee and replace plug. (Don't forget to Teflon tape the plug.)
5. Start pump: water should be produced in 10 minutes or less, the time depending on depth to water (not more than 20') and length of horizontal run (10' of

horizontal suction pipe = 1' of vertical lift due to friction losses in the pipe).

If no water is produced within 10 minutes, stop pump, release all pressure, remove priming plug, refill and try again.

**⚠WARNING** Hazardous pressure and risk of explosion and scalding. If pump is run continuously at no flow (that is, with discharge shut off or without priming), water may boil in pump and piping system. Under steam pressure, pipes may rupture, blow off of fittings or blow out of pump ports and scald anyone near.

To prevent explosion, do the following:

- A. Be sure discharge (valve, pistol grip hose nozzle, etc.) is open whenever pump is running.
- B. If pump fails to produce water when attempting to prime, release all pressure, drain pump and refill with cold water after every two attempts.
- C. When priming, monitor pump and piping temperature. If pump or piping begin to feel warm to the touch, shut off pump and allow system to cool off. Release all pressure in system and refill pump and piping with cold water.

## Maintenance

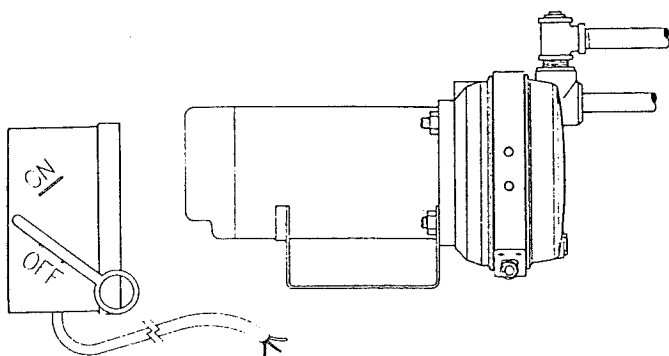

Figure 19—Disconnect Power

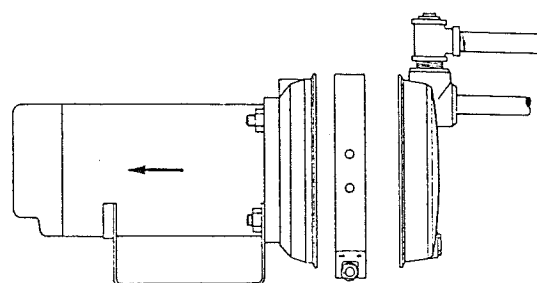

Figure 20—Slide Motor Back

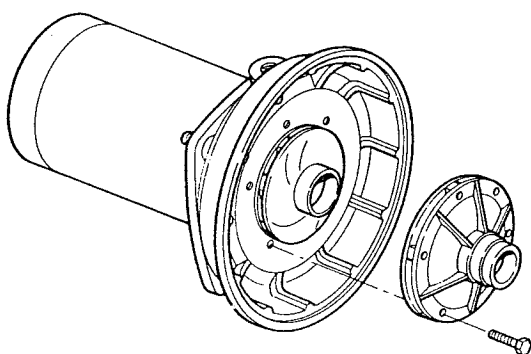

Figure 21—Remove Diffuser

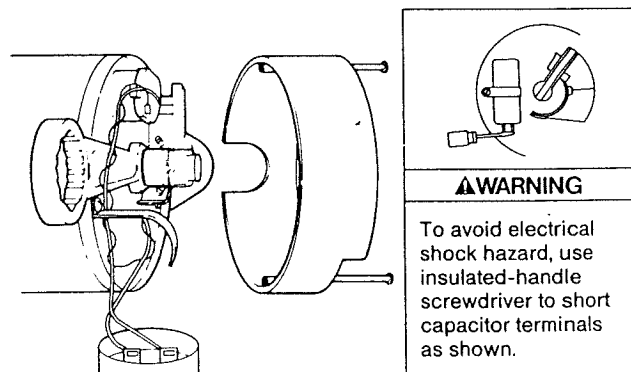

Figure 22—Hold Shaft

### MAINTENANCE

Pump and piping need not be disconnected to repair or replace motor or seal (see Figure 20). If motor is replaced, replace the shaft seal (Key No. 7, Page 12). Keep one on hand for future use.

Be sure to prime pump before starting.

**NOTICE:** Check motor label for lubrication instructions. The mechanical shaft seal in the pump is water lubricated and self-adjusting.

**NOTICE:** Drain pump when disconnecting from service or when it might freeze.

### PUMP DISASSEMBLY

1. Disconnect power to motor.

**NOTICE:** Mark wires for correct assembly.

2. Remove clamp (see Figure 20).
3. Remove pump base mounting bolts. Motor assembly and back half of pump can now be pulled away from pump front half (Figure 20). CAREFULLY remove O-ring.

### CLEANING/REPLACING IMPELLER

**NOTICE:** First, follow instructions under "Pump Disassembly".

1. Remove four screws fastening diffuser to seal plate; remove diffuser (see Figure 21). Exposed impeller can now be cleaned.
2. If impeller must be replaced, loosen two machine screws and remove motor canopy (see Figure 22).
3. **WARNING** Capacitor voltage may be hazardous. To discharge capacitor, hold insulated handle screwdriver **BY THE HANDLE** and short capacitor terminals together (see Figure 22). Do not touch metal screwdriver blade or capacitor terminals. If in doubt, consult a qualified electrician.
4. Unscrew capacitor clamp and remove capacitor. Do not disconnect capacitor wires to motor.
5. Slide 7/16" open end wrench in behind spring loaded switch on motor end of shaft; hold motor shaft with wrench on shaft flats and unscrew impeller by turning counterclockwise when looking into eye of impeller.
6. To reinstall, reverse steps 1 through 5.
7. See directions under "Pump Reassembly," Page 10.



## Maintenance (Continued)

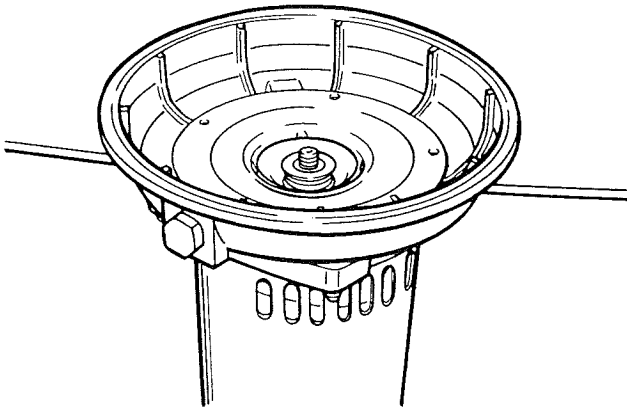

Figure 23—Remove Seal Plate

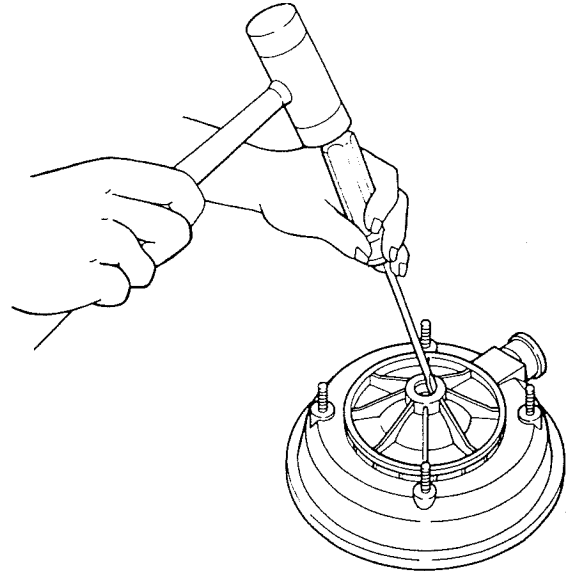

Figure 24—Tap Out Seal

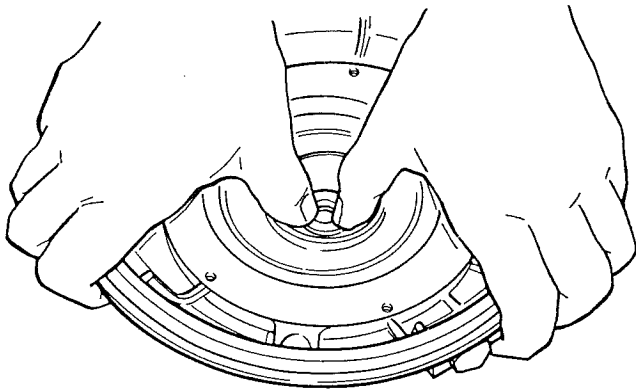

Figure 25—Press In New Seal

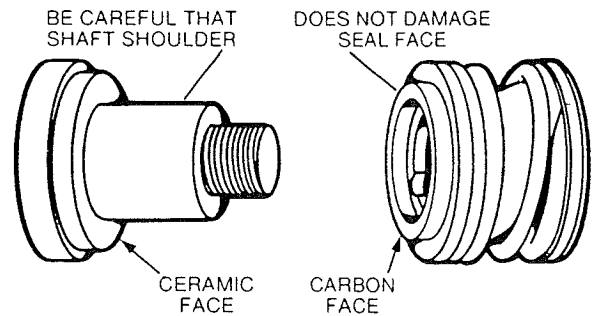

Figure 26—Protect Seal Faces

### REMOVING OLD SEAL

1. Follow instructions under "Pump Disassembly".
2. Follow steps 2 through 5 under "Cleaning/ Replacing Impeller".
3. Unscrew four nuts holding pump back half to motor. Remove rotating half of seal by placing two screwdrivers under back half of pump body and **carefully** prying up (Figure 23). Back half of pump body will slide off shaft, bringing seal with it.

**NOTICE:** Be sure you do not scratch or mar shaft; if shaft is marred, it must be dressed smooth with fine emery or crocus cloth before installing new seal. **DO NOT** reduce shaft diameter!

4. Place pump body half face down on flat surface and tap out stationary half of seal (see Figure 24).

**NOTICE:** Be sure you tap on ceramic seat, not on copper heat sink. Do not disturb heat sink (Key No. 6, Page 12).

### INSTALLING NEW SEAL

1. Clean seal cavity in copper heat sink. **Do not disturb heat sink.** (If heat sink is moved or dislodged, see instructions for "Installing Copper Heat Sink", Page 10).
2. Wet outer edge of Rubber Cup on ceramic seat with liquid soap. Be sparing!

3. Put clean cardboard washer on seal face. With thumb pressure, press ceramic seal half firmly and squarely into seal cavity in copper heat sink (See Figure 25). Polished face of ceramic seat is up. If seal will not seat correctly, remove, placing seal **face up** on bench. Reclean cavity, seal should now seat correctly.
4. If seal does not seat correctly after recleaning cavity, place a cardboard washer over polished seal face and **carefully** press into place using a piece of standard 3/4" pipe as a press.

**NOTICE:** Be sure you do not scratch seal face.

5. Dispose of cardboard washer and recheck seal face to be sure it is free of dirt, foreign particles, scratches and grease.
6. Inspect shaft to be sure it is free of nicks and scratches.
7. Reassemble pump body half to motor flange. **BE SURE** it is right side up.
8. Apply liquid soap sparingly (one drop is sufficient) to inside diameter of rotating seal member.
9. Slide rotating seal member (carbon face first) onto shaft until rubber drive ring hits shaft shoulder.

**NOTICE:** Be sure not to nick or scratch carbon face of seal when passing it over threaded shaft end or shaft shoulder. The carbon surface must remain clean or short seal life will result.

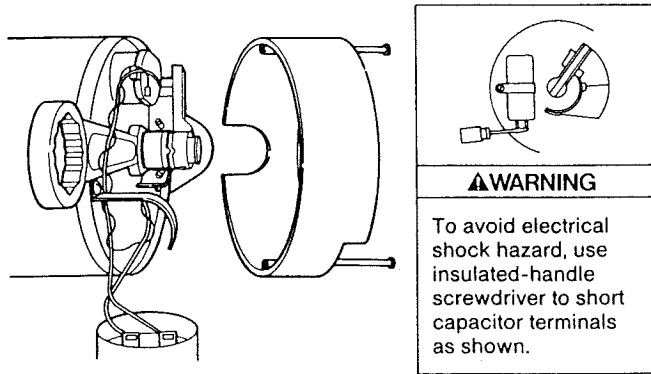

Figure 27—Hold Shaft

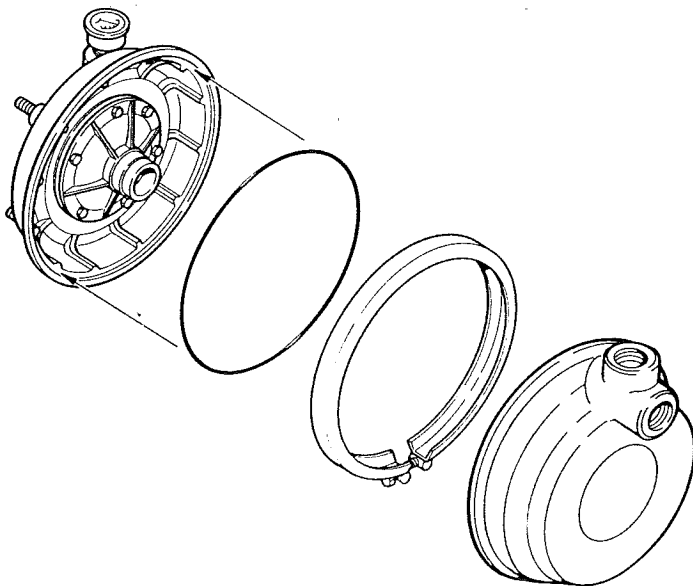

Figure 28—Assemble Pump

10. Hold motor shaft with 7/16" open end wrench on shaft flats and screw impeller onto shaft. **Be sure you do not touch capacitor terminals with body or any metal object.** Tightening impeller will automatically locate seal in correct position.
11. Remount diffuser on pump body half with five screws.
12. Follow instructions under "Pump Reassembly".

**NOTICE:** If the copper heat sink moves or shifts during seal removal, it should be removed and reinstalled.

#### PUMP REASSEMBLY

1. Clean O-ring and O-ring groove.
2. Put O-ring in groove on face of flange; put pump halves together (see Figure 28).
3. **BE SURE** inside of clamp is clean. Place clamp on pump halves; snug up. Alternately tighten screw and tap clamp with mallet to seat O-ring (see Figure 29).
4. Replace base mounting bolts.
5. Replace pressure switch tubing and motor wiring; close draincock.

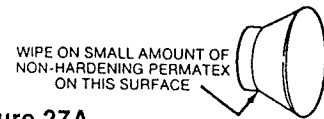

Figure 27A

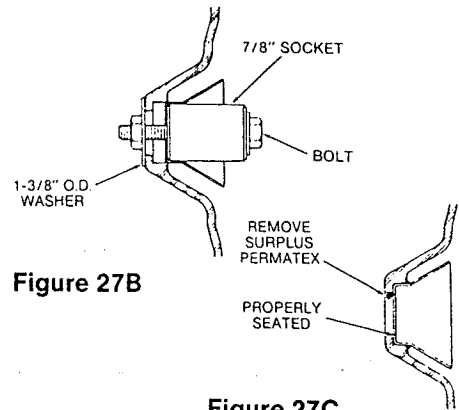

Figure 27B

Figure 27C

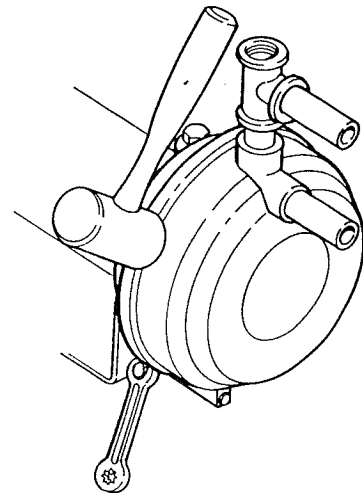

Figure 29—Tap Clamp While Tightening

6. Prime pump according to instructions. See "Operation."
7. Check for leaks.

#### COPPER HEAT SINK REMOVAL

Remove Ceramic portion of sink (see "Removing Old Seal"). Grasp with fingers at the large end and move back and forth. Be careful not to deform it.

#### COPPER HEAT SINK INSTALLATION

1. Clean off all sealant and foreign material.
2. Clean out heat sink cavity in seal plate.
3. Apply thin layer of non-hardening Permatex on outer surface of heat sink (part that fits into cavity, Figures 27A and 27C).
4. Using standard 7/8" socket, bolt, and 1 3/8" washer pull heat sink into cavity as shown in Figure 27B.
5. Clean out any surplus Permatex from insert cavity where new seal will be located (Figure 27C).
6. Follow steps 2 through 11 under "Installing New Seal".

## Troubleshooting Chart

SYMPTOM	POSSIBLE CAUSE(S)	CORRECTIVE ACTION
Motor will not run	<ol style="list-style-type: none"> <li>1. Disconnect switch is off</li> <li>2. Fuse is blown</li> <li>3. Starting switch is defective</li> <li>4. Wires at motor are loose, disconnected, or wired incorrectly</li> </ol>	<ol style="list-style-type: none"> <li>1. Be sure switch is on</li> <li>2. Replace fuse</li> <li>3. Replace starting switch</li> <li>4. Refer to instructions on wiring. Check and tighten all wiring.</li> </ol>
Motor runs hot and overload kicks off	<ol style="list-style-type: none"> <li>1. Motor is wired incorrectly</li> <li>2. Voltage is too low</li> </ol>	<ol style="list-style-type: none"> <li>1. Refer to instructions on wiring</li> <li>2. Check with power company. Install heavier wiring if wire size is too small. See Electrical, P. 7.</li> </ol>
Motor runs but no water is delivered  *(Note: Check prime before looking for other causes. Unscrew priming plug and see if there is water in priming hole.)	<ol style="list-style-type: none"> <li>*1. Pump in a new installation did not pick up prime through:               <ol style="list-style-type: none"> <li>a. Improper priming</li> <li>b. Air leaks</li> <li>c. Leaking foot valve</li> </ol> </li> <li>*2. Pump has lost its prime through:               <ol style="list-style-type: none"> <li>a. Air leaks</li> <li>b. Water level below suction of pump</li> </ol> </li> <li>3. Impeller is plugged</li> <li>4. Check valve or foot valve is stuck in closed position</li> <li>5. Pipes are frozen</li> <li>6. Foot valve and/or strainer are buried in sand or mud</li> </ol>	<ol style="list-style-type: none"> <li>1. In new installation:               <ol style="list-style-type: none"> <li>a. Re-prime according to instructions</li> <li>b. Check all connections on suction line.</li> <li>c. Replace foot valve</li> </ol> </li> <li>2. In installation already in use:               <ol style="list-style-type: none"> <li>a. Check all connections on suction line and shaft seal</li> <li>b. Lower suction line into water and re-prime. If receding water level in well exceeds suction lift, a deep well pump is needed.</li> </ol> </li> <li>3. Clean impeller; see Maintenance</li> <li>4. Replace check valve or foot valve</li> <li>5. Thaw pipes. Bury pipes below frost line. Heat pit or pump house.</li> <li>6. Raise foot valve and/or strainer above well bottom</li> </ol>
Pump does not deliver water to full capacity (Also check point 3 immediately above)	<ol style="list-style-type: none"> <li>1. Water level in well is lower than estimated</li> <li>2. Steel piping (if used) is corroded or limed, causing excess friction</li> <li>3. Offset piping is too small in size</li> </ol>	<ol style="list-style-type: none"> <li>1. A deep well jet pump may be needed (over 20 ft. to water)</li> <li>2. Replace with plastic pipe where possible, otherwise with new steel pipe</li> <li>3. Use larger offset piping</li> </ol>

**TABLE II**  
**PERFORMANCE CHART (IN GALLONS PER MINUTE)**

DISCHARGE PRESSURE P.S.I.	390.262401 1 H.P.				390.262501 1½ H.P.				390.262601 2 H.P.			
	DISTANCE ABOVE WATER											
	5'	10'	15'	20'	5'	10'	15'	20'	5'	10'	15'	20'
10	65	59	56	48	80	71	68	56	83	78	68	57
15	58	55	50	45	77	68	66	55	81	77	67	56
20	51	47	44	39	69	63	60	54	78	76	66	55
25	42	37	34	29	59	55	50	46	72	69	62	54
30	31	26	22	—	49	44	36	33	61	56	50	45
35	18	4	—	—	36	27	12	—	46	41	22	7
DISCHARGE PIPE TAPPING	1½" NPT				1½" NPT				1½" NPT			
SUCTION PIPE TAPPING	1½" NPT				1½" NPT				1½" NPT			

# SEARS "HYDRO-GLASS"® CENTRIFUGAL PUMPS

MODELS 390.262401, 390.262501, AND 390.262601

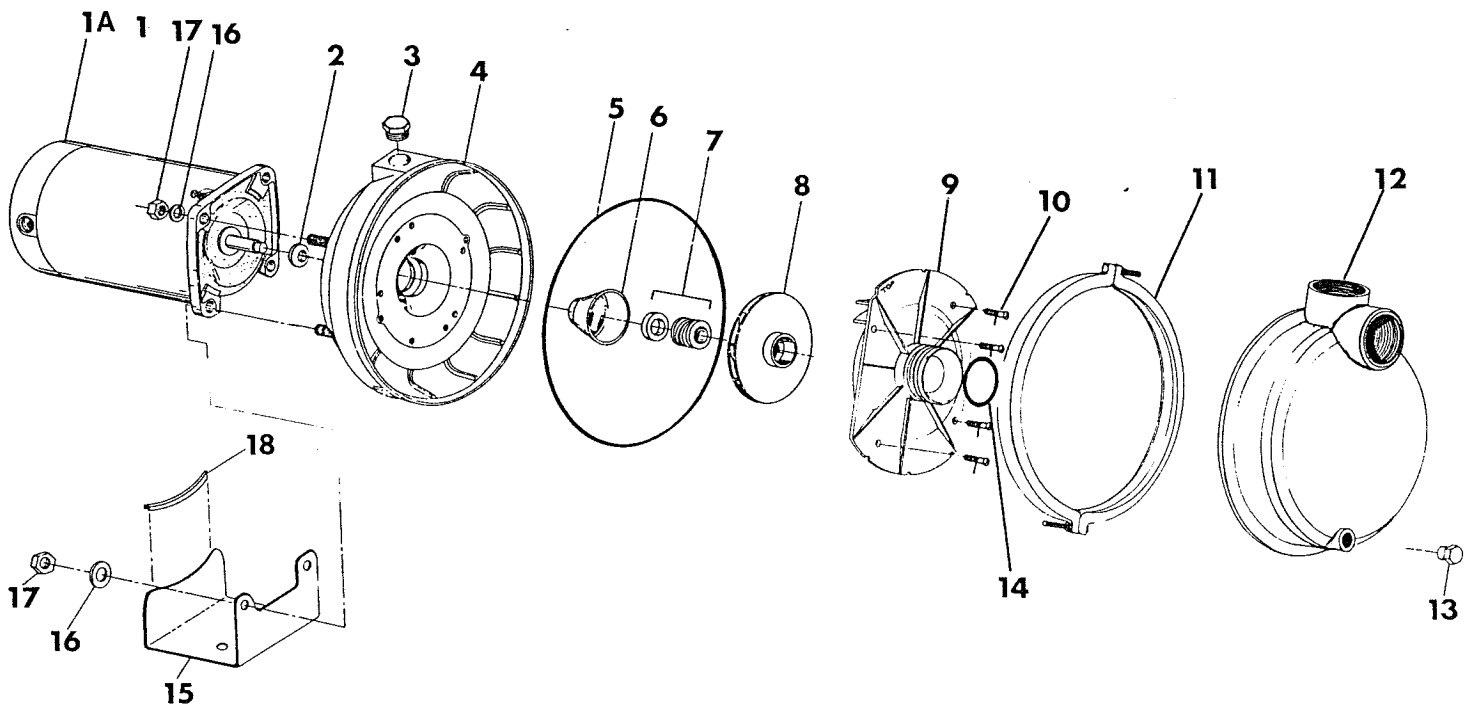

**SEARS "HYDRO-GLASS"® CENTRIFUGAL PUMPS**  
**MODELS 390.262401, 390.262501, AND 390.262601**

Key No.	Part Description	390.262401 115/230V 60Cy/1Ph 1 HP	390.262501 115/230V 60Cy/1Ph 1½ HP	390.262601 230V 60Cy/1Ph 2 HP
1	Motor	J218-596AC	J218-601AC	J218-880AC
1A	Motor Canopy	U18-1235	U18-1235	U18-1235
2	Slinger	C69-2	C69-2	C69-2
3	Priming Plug ½" NPT	**	**	**
4	Tank Body Back Half Complete (Includes No. 3)	L276-35P1	L276-35P1	L276-35P1
5	"O" Ring	U9-389	U9-389	U9-389
6	Seal Plate Insert	J3-2	J3-2	J3-2
7	Shaft Seal for ⅝" Shaft	2784	2784	2784
8	Impeller	C105-138PBB	C105-137PH	C105-137PJ
9	Diffuser	C1-258PA	C1-258PB	C1-258P
10	Screw #8-32 RH (4 Required)	U30-542SS	U30-869SS	U30-869SS
●	Lockwasher #8	**	**	**
11	"V" Clamp	C19-54SS	C19-54SS	C19-54SS
12	Tank Body Front Half (Includes No. 13)	C176-53P	C176-53P	C176-53P
13	Drain Plug ¼ NPT	**	**	**
14	"O" Ring	U9-226	U9-226	U9-226
15	Base	J104-9C	J104-9C	J104-9C
16	Washer 5/16 (4 Required)	U43-11ZP	U43-11ZP	U43-11ZP
17	Nut 5/16-18 (4 Required)	U36-37ZP	U36-37ZP	U36-37ZP
18	Rubber Pad	C35-5	C35-5	C35-5
●	Owner's Manual	F642-7985	F642-7985	F642-7985

● Not illustrated.

\*\* Purchase Locally

**SEARS**

**owners  
manual**

**MODEL NO.**  
390.262401  
390.262501  
390.262601

**HOW TO ORDER  
REPAIR PARTS**

**SEARS SERVICE  
IS AT YOUR SERVICE  
WHEREVER YOU LIVE  
OR MOVE IN THE U.S.A.**

# **"HYDRO-GLASS"® SELF-PRIMING CENTRIFUGAL PUMP**

Now that you have purchased your Centrifugal Pump, should a need ever exist for repair parts or service, simply contact any Sears Service Center. Be sure to provide all pertinent facts when you call or visit.

The **Model Number** of your Centrifugal Pump will be found attached to the side of the pump body.

WHEN ORDERING REPAIR PARTS, ALWAYS GIVE THE FOLLOWING INFORMATION:

- PART NUMBER
- PART DESCRIPTION
- MODEL NUMBER
- NAME OF ITEM

All parts listed may be ordered from any Sears Service Center.

If the parts you need are not stocked locally, your order will be electronically transmitted to a Sears Repair Parts Distribution Center for handling.

When Sears arranges the installation, you can be sure the job is done right. We will arrange for professional workmanship . . . and we'll take care of the entire project. What's more, during installation you get insured protection . . . against property damage and also against accidents to workmen. All you have to do is talk to your Sears salesperson or call your nearest Sears store today for detailed information.

Sears, Roebuck and Co., Chicago, Ill. 60684 U.S.A.